



ON Semiconductor®

<http://onsemi.com>

LV5768M

Bi-CMOS LSI

1-channel Step-down Switching Regulator

Overview

The LV5768M is a 1-channel step-down switching regulator.

Functions

- 1 channel step-down switching regulator controller.
- Frequency decrease function at pendent.
- Load-independent soft start circuit.
- ON/OFF function.
- Built-in pulse-by-pulse OCP circuit. It is detected by using ON resistance of an external MOS.
- Synchronous rectification
- Current mode control

Specifications

Absolute Maximum Ratings at Ta = 25°C

Parameter	Symbol	Conditions	Ratings	Unit
Supply voltage	V _{IN} max		45	V
Allowable pin voltage	V _{IN} , SW		45	V
	HDRV, CBOOT		52	V
	LDRV		6.0	V
	Between CBOOT to SW		6.0	V
	Between CBOOT to HDRV			
	EN, ILIM		V _{IN} +0.3	V
	Between V _{IN} to ILIM		1.0	V
	V _{DD}		6.0	V
SS, FB, COMP,RT		V _{DD} +0.3	V	
Allowable Power dissipation	Pd max	Mounted on a specified board. *	0.9	W
Operating temperature	T _{opr}		-40 to +85	°C
Storage temperature	T _{stg}		-55 to +150	°C

* Specified board : 114.3mm × 76.1mm × 1.6mm, glass epoxy board.

Stresses exceeding Maximum Ratings may damage the device. Maximum Ratings are stress ratings only. Functional operation above the Recommended Operating Conditions is not implied. Extended exposure to stresses above the Recommended Operating Conditions may affect device reliability.

LV5768M

Recommended Operating Range at $T_a = 25^\circ\text{C}$

Parameter	Symbol	Conditions	Ratings	Unit
Supply voltage range	V_{IN}		8.5 to 42	V
Error amplifier input voltage	V_{FB}		0 to 1.6	V
Oscillatory frequency	F_{OSC}		80 to 500	kHz

Electrical Characteristics at $T_a = 25^\circ\text{C}$, $V_{IN} = 12\text{V}$

Parameter	Symbol	Conditions	Ratings			Unit
			min	typ	max	
Reference voltage block						
Internal reference voltage	V_{ref}	Including offset of E/A	0.654	0.67	0.686	V
5V power supply	V_{DD}	$I_{OUT} = 0$ to 5mA	4.7	5.2	5.7	V
Triangular waveform oscillator block						
Oscillation frequency	F_{OSC}	$R_T = 220\text{k}\Omega$	110	125	140	kHz
Frequency variation	$F_{OSC DV}$	$V_{IN} = 8.5$ to 42V		1		%
Oscillation frequency fold back detection voltage	$V_{OSC FB}$	FB voltage detection after SS ends		0.1		V
Oscillation frequency after fold back	$F_{OSC FB}$			$1/3F_{OSC}$		kHz
ON/OFF circuit block						
IC start-up voltage	$V_{EN on}$		2.5	3.0	3.5	V
IC off voltage	$V_{EN off}$		1.0	1.2	1.4	V
Soft start circuit block						
Soft start source current	$I_{SS SC}$	$EN > 3.5\text{V}$	4	5	6	μA
Soft start sink current	$I_{SS SK}$	$EN < 1\text{V}$, $V_{DD} = 5\text{V}$		2		mA
UVLO circuit block						
UVLO lock release voltage	V_{UVLO}			8		V
UVLO hysteresis	$V_{UVLO H}$			0.7		V
Error amplifier						
Input bias current	$I_{EA IN}$				100	nA
Error amplifier gain	G_{EA}		1000	1400	1800	$\mu\text{A/V}$
Sink output current	$I_{EA OSK}$	FB = 1.0V		-100		μA
Source output current	$I_{EA OSC}$	FB = 0V		100		μA
Current detection amplifier gain	G_{ISNS}			1.5		
over current limiter circuit block						
Reference current	I_{LIM1}		-10%	18.5	+10%	μA
Over current detection comparator offset voltage	$V_{LIM OFS}$		-5		+5	mV
Over current detection comparator common mode input range			$V_{IN} - 0.45$		V_{IN}	V
PWM comparator						
Input threshold voltage ($F_{OSC} = 125\text{kHz}$)	$V_t \text{ max}$	Duty cycle = DMAX	0.9	1.0	1.1	V
	$V_t 0$	Duty cycle = 0%	0.4	0.5	0.6	V
Maximum ON duty	DMAX		85	90	95	%
Output block						
Output stage ON resistance (the upper side)	R_{ONH}			5		Ω
Output stage ON resistance (the under side)	R_{ONL}			5		Ω
Output stage ON current (the upper side)	I_{ONH}		240			mA
Output stage ON current (the under side)	I_{ONL}		240			mA
The whole device						
Standby current	I_{CCS}	$EN < 1\text{V}$			10	μA
Mean consumption current	I_{CCA}	$EN > 3.5\text{V}$		3		mA

Continued on next page.

LV5768M

Continued from preceding page.

Parameter	Symbol	Conditions	Ratings			Unit
			min	typ	max	
Security function						
Protection function operating temperature at high temperature	TSD on	* Design certification		170		°C
Protection function hysteresis at high temperature	TSD hys	* Design certification		30		°C

Package Dimensions

unit : mm (typ)

3111A

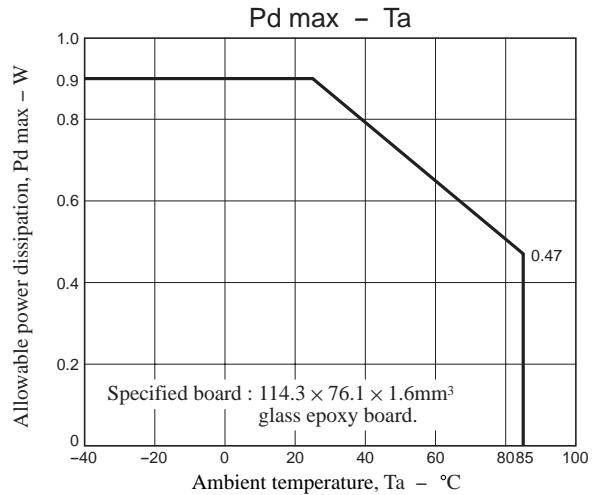
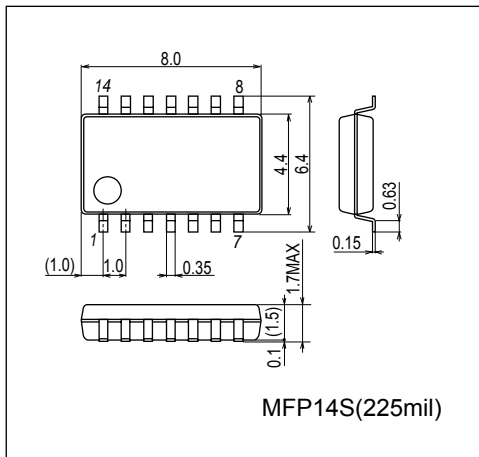

Pin Assignment

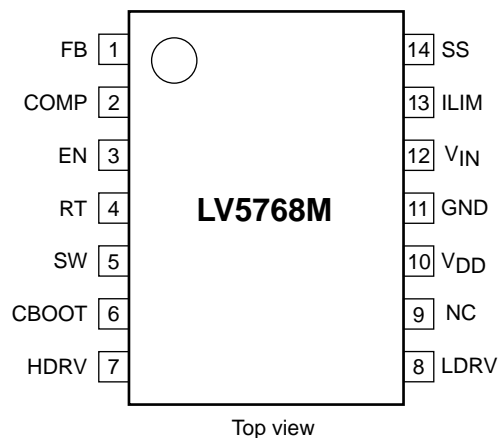

LV5768M

Block Diagram

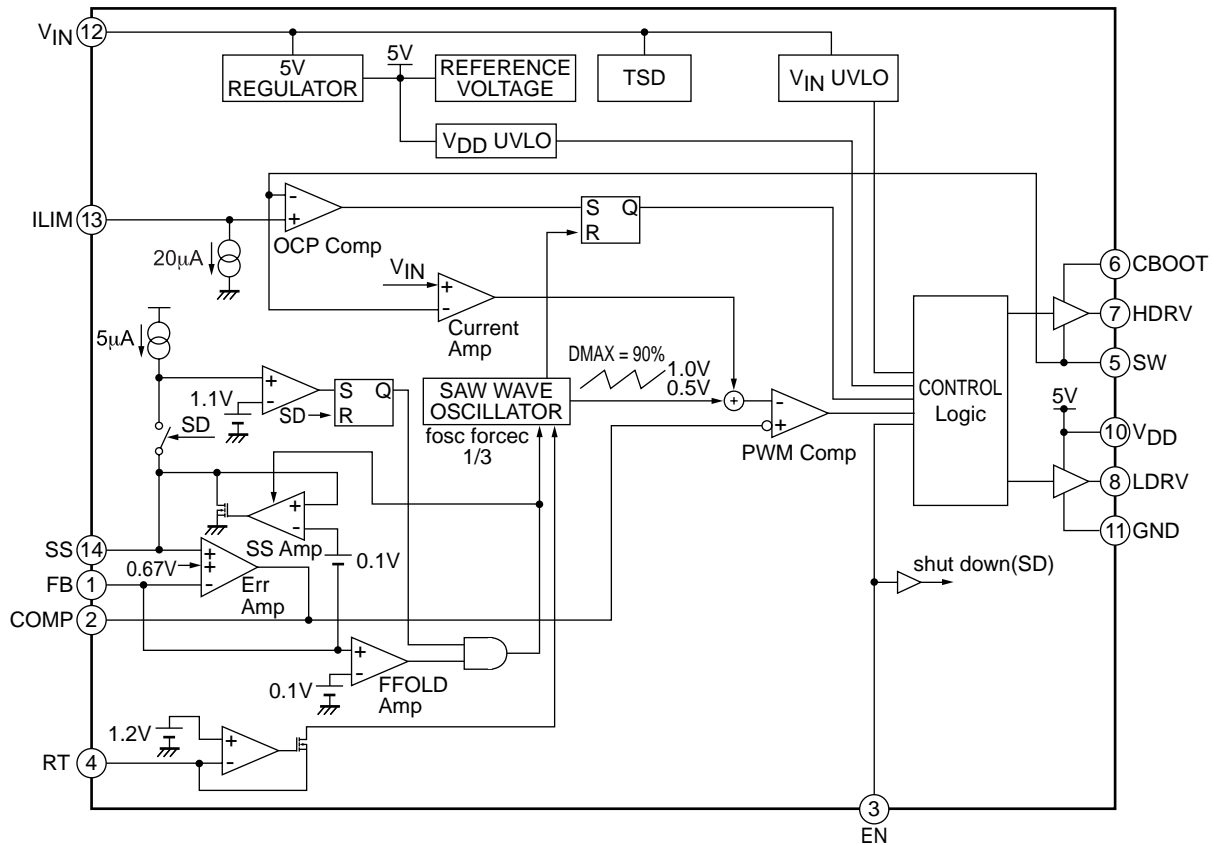

Pin Function

Pin No.	Pin name	Description
1	FB	Error amplifier reverse input pin. By operating the converter, the voltage of this pin becomes 0.67V. The voltage in which the output voltage is divided by an external resistance is applied to this pin. Moreover, when this pin voltage becomes 0.1V or less after a soft start ends, the oscillatory frequency becomes 1/3.
2	COMP	Error amplifier output pin. Connect a phase compensation circuit between this pin and GND.
3	EN	ON/OFF pin.
4	RT	Oscillation frequency setting pin. Resistance is connected with this pin between GND.
5	SW	Pin to connect with switching node. Upper part NchMOSFET external a source is connected with lower side NchMOSFET external a drain.
6	CBOOT	Bootstrap capacity connection pin. This pin becomes a GATE drive power supply of an external NchMOSFET. Connect a bypath capacitor between CBOOT and SW.
7	HDRV	An external the upper MOSFET gate drive pin.
8	LDRV	An external the lower MOSFET gate drive pin.
9	N.C.	No connection
10	V _{DD}	Power supply pin for an external the lower MOS-FET gate drive.
11	GND	Ground pin. Each reference voltage is based on the voltage of the ground pin.
12	V _{IN}	Power supply pin. This pin is monitored by UVLO function. When the voltage of this pin becomes 8V or more by UVLO function, The IC starts and the soft start function operates.
13	ILIM	Reference current pin for current detection. The sink current of about 18.5µA flows to this pin. When a resistance is connected between this pin and V _{IN} outside and the voltage applied to the SW pin is lower than the voltage of the terminal side of the resistance, the upper NchMOSFET is off by operating the current limiter comparator. This operation is reset with respect to each PWM pulse.
14	SS	Pin to connect a capacitor for soft start. A capacitor for soft start is charged by using the voltage of about 5µA. This pin ends the soft start period by using the voltage of about 1.1V and the frequency fold back function becomes active.

LV5768M

I/O pin equivalent circuit chart

Pin No.	Equivalent Circuit
FB, SS V _{DD} (10) FB (1) SS (14) GND (11)	<p>Standard voltage 0.67V</p> <p>1.3V</p> <p>0.1V</p> <p>1.1V</p>
COMP V _{DD} (10) COMP (2) GND (11)	<p>1.6V</p>
EN V _{IN} (12) EN (3) GND (11)	
RT V _{DD} (10) RT (4) GND (11)	

Continued on next page.

LV5768M

Continued from preceding page.

Pin No.	Equivalent Circuit
SW, CBOOT, HDRV	
LDRV	
V _{DD}	
ILIM	

LV5768M

Boot sequence, UVLO, and TSD operation

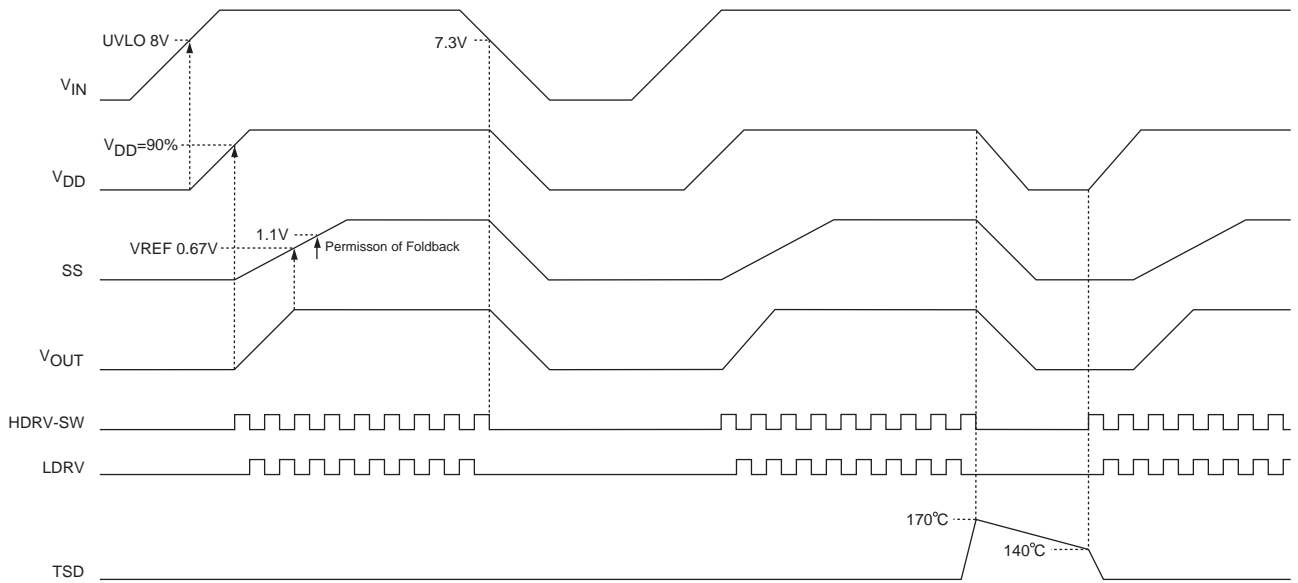

Sequence of overcurrent protection

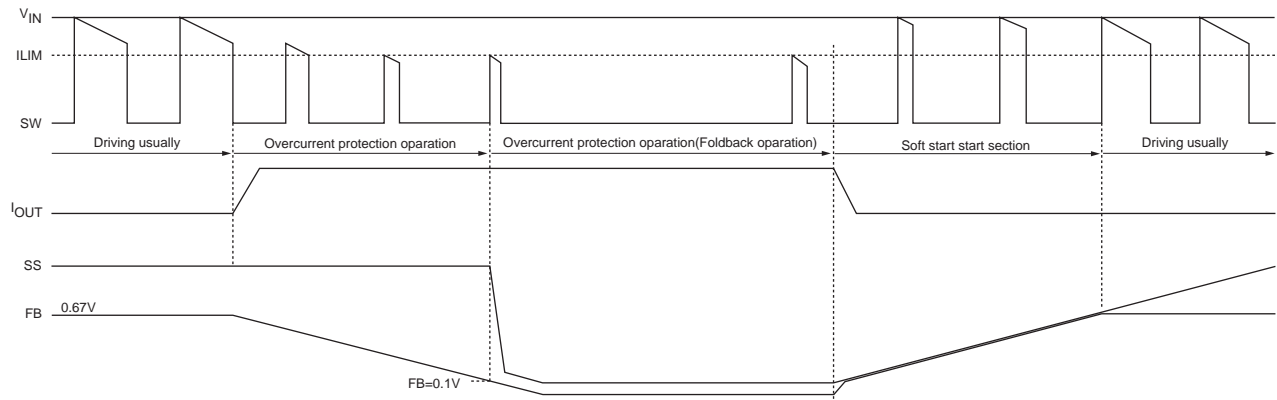

LV5768M

Sample Application Circuit

$V_{IN}=24V$, $V_{OUT}=12V$, $I_{OUT}=7A$, $F_{osc}=100kHz$

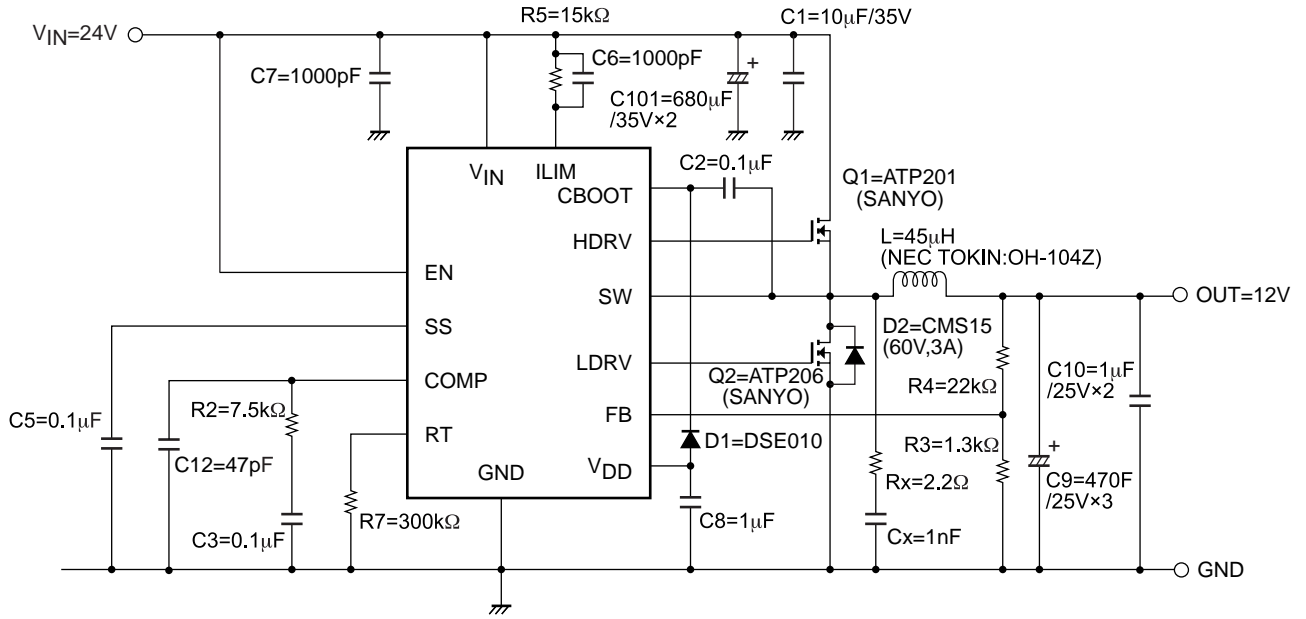

• Part selection and set

1) Output voltage set

Output voltage (V_{OUT}) is shown the equation (1).

$$V_{OUT} = \left(1 + \frac{R4}{R3}\right) \times V_{REF} = \left(1 + \frac{22k\Omega}{1.3k\Omega}\right) \times 0.67 \text{ (typ)} \quad [V] \quad (1)$$

Ex) To set output voltage of 12V, set resistors as follows: R3=1.3kΩ and R4=22kΩ.

2) Soft start set

Soft start capacitor (C5) is obtained by the equation (2).

$$C5 = \frac{I_{SS} \times T_{SS}}{V_{REF}} = \frac{5\mu \times T_{SS}}{0.67V} \quad [\mu F] \quad (2)$$

I_{SS}: Charge current value, T_{SS}: soft start time

Ex) To set soft start time of 15ms (approx.), set C5=0.1μF.

3) Overcurrent protector set

Overcurrent limit setting resistor (R5) is obtained by the equation (3).

$$R5 = \frac{R_{dson} \times I_{L \max}}{I_{lim}} = \frac{R_{dson} \times I_{L \max}}{18.5\mu} \quad [\Omega] \quad (3)$$

I_{lim}: ILIM current value,

I_{Lmax}: the maximum value of coil current,

R_{dson}: Ron between drain and source of Q1 (upper Nch MOS FET).

Ron of ATP201 ≈ 23mΩ (when VGS=4.5V at 25°C)

Ex) To set current limit operation point to 11.3A (load current) where coil peak current value is 12A (approx.), set R5 = 15kΩ. Set an optimum resistor taking variation of ON resistor into consideration due to temperature change and make sure to confirm it with the user's specific board. For C6, connect a capacitor of 1000pF to filter unwanted noise for the proper operation of current limiting.

ON resistor of FET

* R_{dson} of FET has its own temperature coefficient and the resistor becomes higher in proportion to the temperature.

* To set R_{dson} value within the range of operating temperature, it is advisable that the user confirm the data sheet by the FET supplier.

4) How to set oscillation frequency

Oscillation frequency Fosc is adjustable by RT resistor as shown in the correlation chart as follows:

SW frequency setting range: 80kHz to 500kHz

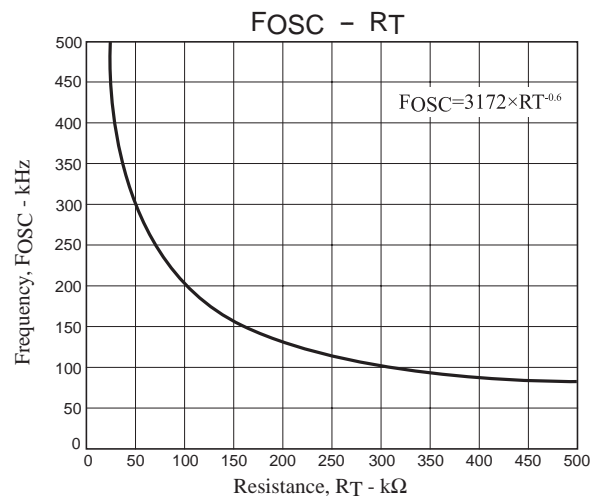

5) Boot strap capacitor set

For boot strap capacitor C2, use capacitor 100 times larger than Ciss of power MOSFET.

6) Phase compensation set

Since LV5768M adopts current mode control, low ESR capacitor and solid polymer capacitor such as OS capacitor can be used as output capacitor with simple phase compensation.

***Frequency characteristics**

Frequency characteristics of LV5768M consist of the following transfer functions.

- (1) Output resistor bleeder ; H_R
- (2) Voltage gain of error amplifier ; G_{VEA}
Current gain (Trans conductance) ; G_{MEA}
- (3) Impedance of external phase compensation part ; Z_C
- (4) Current sense loop gain ; G_{CS}
- (5) Output smoothing impedance ; Z_O

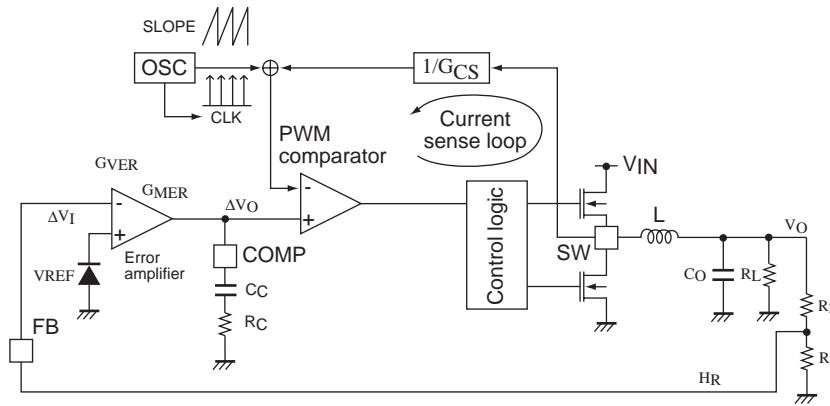

Fig. Current control loop of LV5768M

Closed loop gain is obtained by the equation (5)

$$G = H_R \times G_{MEA} \times Z_C \times G_{CS} \times Z_O$$

$$R_5 = \frac{V_{REF}}{V_O} \times G_{MER} \times (R_C + \frac{1}{S C_C}) \times G_{CS} \times \frac{R_L}{1 + S C_O R_L} \quad (4)$$

From the equation (4), the frequency characteristics of closed loop gain is given by pole fp1 which consists of output capacitor Co and output load resistor RL, zero point fz which is given by external resistor Rc and capacitor Cc of phase compensation pin COMP and pole fp2 which is given by output impedance ZO and external phase compensation capacitor Cc of error amplifier. fp1, fz, fp2 are given by the equation (5), (6) and (7).

$$fp1 = \frac{1}{2\pi C_O R_L} \quad (5), \quad fz = \frac{1}{2\pi C_C R_C} \quad (6), \quad fp2 = \frac{1}{2\pi \times Z_{EA} \times C_C} \quad (7)$$

***Calculation of phase compensation external constants RC and CC**

In general, the frequency where closed loop gain becomes 1 (zero cross frequency fzc) should be 1/10 of the switching frequency (or 1/5 at the highest) to stabilize the operation of switching regulator.

Ex) When switching frequency of LV5768M is 100kHz:

$$f_{zc} = \frac{100kHz}{10} \approx 10kHz \quad (8)$$

Since the closed loop gain becomes 1 with this frequency, the equation (7) = 1

$$\frac{V_{ref}}{V_O} \times G_{MEA} \times (R_C + \frac{1}{S C_C}) \times G_{CS} \frac{R_L}{1 + S C_O R_L} = 1 \quad (9)$$

In reality for zero cross frequency, in the impedance of phase compensation capacity, since capacity element $\frac{1}{S C_C}$

becomes lower enough than the resistor element RC: $R_C \gg \frac{1}{S C_C}$ (10)

The equation (9) becomes
$$\frac{V_{ref}}{V_O} \times G_{MEA} \times R_C \times \frac{R_L}{1+2\pi \times f_{ZC} \times C_O \times R_L} = 1 \quad (11)$$

From the equation, phase compensation external resistor R_C is obtained by the following formula. However, $G_{CS}=0.67/R_{dson}=29A/V$, $G_{MEA}=1400\mu A/V$.

Given that output is 12V and load resistor is 1.7Ω (7A load):

$$\therefore R_C = \frac{V_O}{V_{ref}} \times \frac{1}{G_{MEA}} \times \frac{1}{G_{CS}} \times \frac{1+2\pi \times f_{ZC} \times C_O \times R_L}{R_L} \quad (12)$$

$$= \frac{12}{0.67} \times \frac{1}{1400\mu A/V} \times \frac{1}{29A/V} \times \frac{1+2 \times 3.14 \times 10k \times 1410\mu \times 1.7}{1.7}$$

$$\approx 39k\Omega \quad (13)$$

This is the external resistor value R_C obtained from this calculation (the calculation reveals that the last block where load resistor R_L is inserted is $1 \ll 2\pi \times f_{ZC} \times C_O \times R_L$. Therefore, there is no need for depending R_L).

When point zero f_Z (6) and pole f_{p1} (5) are the same values, they cancel out each other. Hence, there is only one pole frequency for the phase characteristics of closed loop gain. In other words, you can obtain characteristics in which waveform is stable because the gain frequency lowers at -20dB/DEC and phase only rotates by -90 degree.

Since (6) = (5) $f_Z = f_{p1} \quad (14)$

$$\frac{1}{2\pi C_O R_C} = \frac{1}{2\pi C_O R_L}$$

$$\therefore C_C = \frac{R_L \times C_O}{R_C} = \frac{1.7 \times 1410\mu}{39k} = 0.062\mu F$$

The external constant between phase compensator pin COMP and GND is obtained as such using ideal equations. In reality, stable phase constant should be defined based on testing under the entire temperature, load and input voltage range. On the other hand, such ideal value is used as starting point for the assessment. In the deliverable evaluation board, the above constants are used as initial value. C_C and R_C are defined according to conditions of transient response. If the influence of noise is significant, it is advisable to increase constant than the C_C value.

7) Input capacitor selection

When switching of the IC occurs, ripple current flows into the input-side capacitor of DC-DC converter. Like input current, the more the output current flows, the more the ripple current into input side capacitor flows. Also, the lower the input voltage is, the more the duty expands. As a result, the ripple current flows more. Allow higher ripple current than the result of the equation. The capacitor of input side should be connected adjacent to the power IC and minimize the inductance from the pattern layout. Execution value is obtained by the equation (15).

$$I_{rip_in} = \sqrt{D(1-D)} \times I_{OUT} \quad [Arms] \quad (15)$$

D represents duty cycle defined by V_{OUT}/V_{IN} .

8) Output capacitor selection

If ceramic capacitor is used to output, output ripple voltage is obtained as follows since the capacitance of ESR is small.

$$V_{rip} = \frac{V_{OUT}}{8 \times L \times C_O \times f_{OSC}^2} \times \left(1 - \frac{V_{OUT}}{V_{IN}}\right) \quad [V] \quad (16)$$

Also if electrolytic capacitor is used to output, output ripple voltage is affected by ESR since the capacitance of ESR is large. In this case, output ripple voltage is obtained by the following equation.

$$V_{rip} = \frac{V_{IN} - V_{OUT}}{f_{OSC} \times V_{IN}} \times \frac{V_{OUT} \times R_C}{L} \quad [V] \quad (17)$$

Since the allowable ripple current of electrolytic capacitor is lower compared to that of ceramic capacitor, the allowable ripple current value must not be exceeded. Execution value is obtained by the following equation.

$$I_{rip_out} = \frac{1}{\sqrt{3}} \times \frac{V_{OUT} (V_{IN} - V_{OUT})}{L \times f_{OSC} \times V_{IN}} \quad [Arms] \quad (18)$$

It is advisable to use ceramic capacitor in combination with electrolytic capacitor to reject high frequency noise. The electrolytic capacitor can be low ESR aluminum electrolytic capacitor or polymer aluminum electrolytic capacitor.

9) Inductor selection

L1: Caution is required due to the heat generation from choke coil caused by overload and load short. The inductance value is determined by output ripple voltage (V_{rip}) and the impedance of output capacitor for switching frequency. The minimum inductance is obtained by the equation (19).

$$L_{min} = \frac{V_{IN} - V_{OUT}}{f_{OSC} \times V_{IN}} \times \frac{V_{OUT} \times R_C}{V_{rip}} \quad [\mu H] \quad (19)$$

In the above equation, ESR is used in place of the impedance of output capacitor. The reason is, the impedance of output capacitor for switching frequency is close to R_C in many cases. However with ceramic capacitor, real impedance is used instead of R_C .

Ex) $V_{IN(max)}=24V$, $V_{OUT}=12V$, $V_{rip}=100mV$, $R_C=9m\Omega$, $f_{OSC}=100kHz$

$$L_{min} = \frac{24V - 12V}{100k \times 24V} \times \frac{12V \times 9m}{20mV} \quad (20)$$

$$\approx 27 [\mu H]$$

In the actual part selection, ripple voltage is defined first, then capacitor and inductor are selected. Take the maximum value and minimum value of input voltage, output voltage and load variation into consideration. Also, the ripple current of inductor is used as basis for output inductor selection in many cases. Ripple current is obtained by the equation (21).

$$I_{rip} = \frac{V_{IN} - V_{OUT}}{f_{OSC} \times L} \times D \quad [A] \quad (21)$$

D represents duty cycle defined by V_{OUT}/V_{IN} .

The important term is the ripple current represented as I_{rip}/I_{OUT} . As long as the ripple element is less than 50%, it should not be a problem. If the ripple element is higher, inductor loss becomes significant.

Ex) $V_{IN}=24V$, $V_{OUT}=12V$, $f_{OSC}=100kHz$, $L=45\mu H$

$$I_{rip} = \frac{24V - 12V}{100k \times 45\mu} \times 0.5 \quad (22)$$

$$= 1.3 [A]$$

10) Power consumption of high side MOSFET

The power consumption in the external high side MOSFET is represented by conduction loss and switching loss. The conduction loss of MOSFET is obtained by the following equation (23).

$$P_{sat} = I_O^2 \times R_{DS(ON)} \times D \quad [W] \quad (23)$$

Since $R_{DS(ON)}$ is affected by temperature, it is advisable to confirm the actual FET temperature and data sheet.

The switching loss of high side MOSFET is obtained by the following equation (24).

$$P_{sw} = V_{IN} \times I_O \times t_{SW} \times f_{SW} \quad [W] \quad (24)$$

I_O : DC output current

t_{SW} : Rise time of switching waveform

f_{SW} : Switching frequency

LV5768M

The junction temperature of high side MOSFET is obtained by the following equation (25).

$$T_j = T_a + (P_{sat} + P_{sw}) \times \theta_{ja} \quad [W] \quad (25)$$

θ_{ja} : Package heat resistor

T_j should not exceed the T_{jmax} as stated in the data sheet.

11) Power consumption of low side MOSFET

The power consumption in low side MOSFET consists of conduction loss from $R_{DS(ON)}$ as well as from body diode and reverse recovery loss. The conduction loss due to $R_{DS(ON)}$ is obtainable by the equation (23) which is represented in the equation (26).

$$P_{sat} = I_O^2 \times R_{DS(ON)} \times (1-D) \quad [W] \quad (26)$$

The conduction loss from body diode occurs when the body diode is conducted forwardly between high side off and low side off zone, which is represented in the equation (27).

$$P_{df} = 2 \times I_O \times V_f \times t_{delay} \times f_{SW} \quad [W] \quad (27)$$

V_f : Forward voltage of body diode

t_{delay} : Delay time immediately before surge of SW node

The total power consumption of low side MOSFET is obtained by the equation (28).

$$P_{ls} = P_{sat} + P_{df} \quad [W] \quad (28)$$

12) Power consumption of LV5768M

The total power consumption of LV5768M is represented in the equation (29) given that the same MOSFET is selected for high side and low side.

$$P_{d_ic} = (2 \times Q_g \times f_{SW} + I_{CCA}) \times V_{IN} \quad [W] \quad (29)$$

I_{CCA} : IC consumption current when switching is stopped.

- Caution for pattern layout

C1: input capacitor

When the IC performs switching, ripple current flows into the input capacitor of DC-DC converter. The capacitor of input should be connected adjacent to the power IC and minimize the inductance from pattern layout. C1 should be connected adjacently to V_{IN} pin of the IC and Q1 (high side FET- drain). If implementation to IC side is not feasible, insert adjacently to Q1.

C7 (bypass capacitor connected to V_{IN} pin of the IC) should be connected adjacently to V_{IN} pin and GND pin. In rare cases, intensive ringing may occur in the V_{IN} pin by connecting bypass capacitor. The recommendation value is 1000pF.

Q1, Q2 (D1): external FET

Both high and low sides are driven by Nch-MOSFET. In Q1, a transition of SW node takes place between V_{IN} and GND by turn on and off, where high frequency noise occurs. The noise affects the surrounding pattern layouts and parts. The high/ low side gate and SW node should be laid out as fat and short as possible without connecting all the way to HDRV, LDRV and SW pins of the IC. HDRV, LDRV and SW pins should be shielded with GND to prevent influence from noise.

When high side FET is turned on, current path is as follows: $V_{IN} + (C1) \rightarrow$ inductor (L) \rightarrow V_{OUT} (load) \rightarrow PGND \rightarrow GND. When low side FET is turned on, current path is as follows: inductor (L) \rightarrow V_{OUT} (load) \rightarrow PGND. By minimizing the area of current path and keeping the pattern layout fat and short, noise is eliminated and error operation is prevented. Hence, Q1, Q2, D1, C1 and C9 should be implemented nearby.

R5,C6: ILIM (overcurrent limiter set pin)

ILIM pin detects overcurrent which is used as set point where current limit comparator in the IC starts operation. The overcurrent limiter is adjustable by the resistor between I_{LIM} pin and V_{IN} pin. When the voltage of SW pin becomes lower than that of I_{LIM} pin, current limit comparator functions and turns off the high side MOSFET. This operation is reset at every PWM pulse.

To filter unwanted noise, C6 should be connected in parallel to the set resistor (the recommendation is 1000pF). R5 and C6 should be implemented adjacently to the V_{IN} side of the IC. If they are apart from the V_{IN} side, detection precision for overcurrent point may be deteriorated.

Small signal system: part for FB, COMP, EN, CBOOT, V_{DD} and SS pins.

The parts should be implemented adjacently to the IC and be connected as short as possible. Also the GND of the parts should have common GND pattern as the IC. FB pattern layout should not be under nor nearby the inductor or SW node. This must be complied to avoid error operation.

ON Semiconductor and the ON logo are registered trademarks of Semiconductor Components Industries, LLC (SCILLC). SCILLC owns the rights to a number of patents, trademarks, copyrights, trade secrets, and other intellectual property. A listing of SCILLC's product/patent coverage may be accessed at www.onsemi.com/site/pdf/Patent-Marking.pdf. SCILLC reserves the right to make changes without further notice to any products herein. SCILLC makes no warranty, representation or guarantee regarding the suitability of its products for any particular purpose, nor does SCILLC assume any liability arising out of the application or use of any product or circuit, and specifically disclaims any and all liability, including without limitation special, consequential or incidental damages. "Typical" parameters which may be provided in SCILLC data sheets and/or specifications can and do vary in different applications and actual performance may vary over time. All operating parameters, including "Typicals" must be validated for each customer application by customer's technical experts. SCILLC does not convey any license under its patent rights nor the rights of others. SCILLC products are not designed, intended, or authorized for use as components in systems intended for surgical implant into the body, or other applications intended to support or sustain life, or for any other application in which the failure of the SCILLC product could create a situation where personal injury or death may occur. Should Buyer purchase or use SCILLC products for any such unintended or unauthorized application, Buyer shall indemnify and hold SCILLC and its officers, employees, subsidiaries, affiliates, and distributors harmless against all claims, costs, damages, and expenses, and reasonable attorney fees arising out of, directly or indirectly, any claim of personal injury or death associated with such unintended or unauthorized use, even if such claim alleges that SCILLC was negligent regarding the design or manufacture of the part. SCILLC is an Equal Opportunity/Affirmative Action Employer. This literature is subject to all applicable copyright laws and is not for resale in any manner.

Looking for pricing, stock, or lifecycle information?

Click below to explore more details on WIN SOURCE:

- ⊖ [View LV5768M-TLM-H on WIN SOURCE](#)
- ⊖ [ON Semiconductor](#) Information

Optimize Your Supply Chain with WIN SOURCE Solutions

- ✓ Global Sourcing Solution
- ✓ Obsolete Management
- ✓ Cost Control Management
- ✓ Shortage Management
- ✓ Alternative Solution
- ✓ Excess Inventory Management