



THE DATASHEET OF LX1664CD



DESCRIPTION

The LX1664/64A and LX1665/65A are monolithic switching regulator controller IC's designed to provide a low cost, high performance adjustable power supply for advanced microprocessors and other applications requiring a very fast transient response and a high degree of accuracy.

Short-circuit Current Limiting without Expensive Current Sense Resistors.

Current-sensing mechanism can use PCB trace resistance or the parasitic resistance of the main inductor. The LX1664A and LX1665A have reduced current sense comparator threshold for optimum performance using a sense resistor. For applications requiring a high degree of accuracy, a conventional sense resistor can be used to sense current.

Programmable Synchronous Rectifier Driver for CPU Core. The main output is adjustable from 1.3V to 3.5V using a 5-bit code. The IC can read a VID signal

set by a DIP switch on the motherboard, or hardwired into the processor's package (as in the case of Pentium® Pro and Pentium II processors). The 5-bit code adjusts the output voltage between 1.30 and 2.05V in 50mV increments and between 2.0 and 3.5V in 100mV increments, conforming to the Intel Corporation specification. The device can drive dual MOSFET's resulting in typical efficiencies of 85 - 90% even with loads in excess of 10 amperes. For cost sensitive applications, the bottom MOSFET can be replaced with a Schottky diode (non-synchronous operation).

Linear Regulator Driver. The LX1664/65 family of devices have a secondary regulator output. This can drive a MOSFET or bipolar transistor as a pass element to construct a low-cost adjustable linear regulator suitable for powering a 1.5V GTL+ bus or 2.5V clock supply.

(continued next page)

KEY FEATURES

- 5-bit Programmable Output For CPU Core Supply
- Adjustable Linear Regulator Driver Output
- No Sense Resistor Required For Short-Circuit Current Limiting
- Designed To Drive Either Synchronous Or Non-Synchronous Output Stages
- Soft-Start Capability
- Modulated, Constant Off-Time Architecture For Fast Transient Response And Simple System Design
- Available Over-Voltage Protection (OVP) Crowbar Driver And Power Good Flag (LX1665 only)

APPLICATIONS

- Socket 7 (Pentium Class) Microprocessor Supplies (including Intel Pentium Processor, AMD-K6™ And Cyrix® 6x86™, Gx86™ and M2™ Processors)
- Pentium II and Deschutes Processor & L2-Cache Supplies
- Voltage Regulator Modules

IMPORTANT: For the most current data, consult Linfinity's web site: <http://www.linfinity.com>.

PRODUCT HIGHLIGHT

LX1665 IN A PENTIUM II SINGLE-CHIP POWER SUPPLY SOLUTION

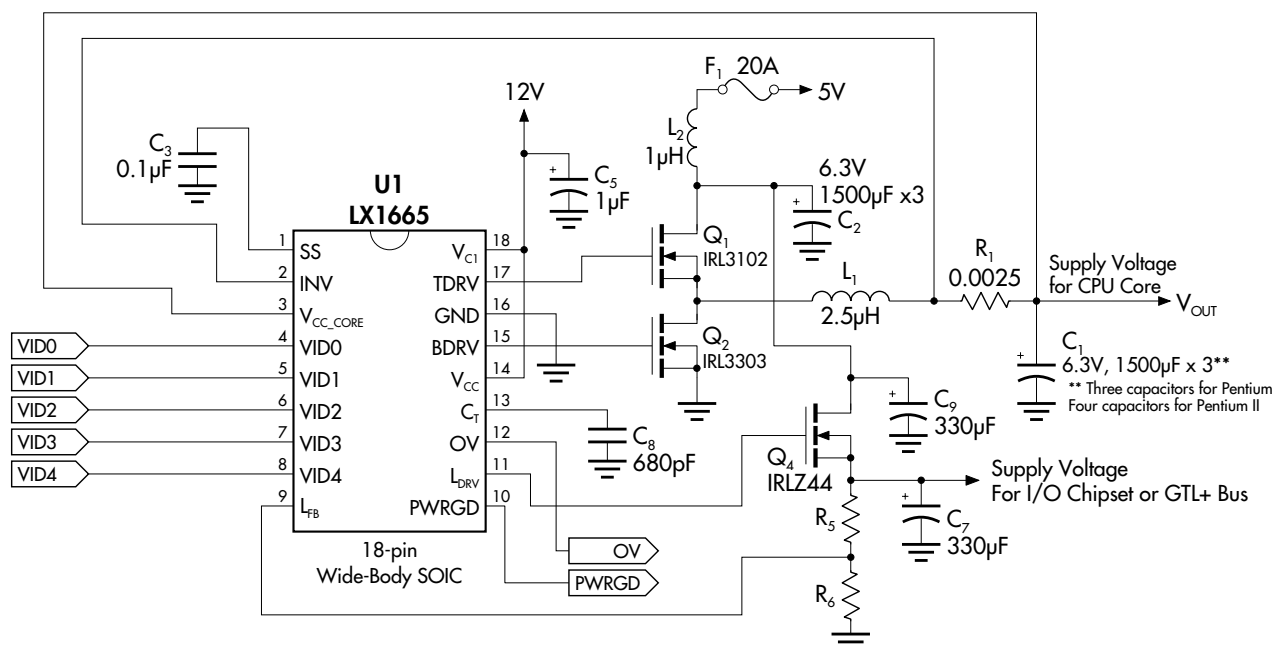

PACKAGE ORDER INFORMATION

T _A (°C)	N Plastic DIP 16-pin	N Plastic DIP 18-pin	D Plastic SOIC 16-pin	DW Plastic SOIC Wide 18-pin
0 to 70	LX1664CN LX1664ACN	LX1665CN LX1665ACN	LX1664CD LX1664ACD	LX1665CDW LX1665ACDW

Note: All surface-mount packages are available in Tape & Reel. Append the letter "T" to part number. (e.g. LX1664CDT)

See next page for Selection Guide

LX1664/64A, LX1665/65A

DUAL OUTPUT PWM CONTROLLERS WITH 5-BIT DAC

PRODUCTION DATA SHEET

DESCRIPTION (con't.)

Smallest Package Size. The LX1664 is available in a narrow body 16-pin surface mount IC package for space sensitive applications. The LX1665 provides the additional functions of Over Voltage Protection (OVP) and Power Good (PWRGD) output drives for applications requiring output voltage monitoring and protection functions.

Ultra-Fast Transient Response reduces system cost. The modulated off-time architecture results in the fastest tran-

sient response for a given inductor, reducing output capacitor requirements, and reducing the total regulator system cost.

Over-Voltage Protection and Power Good Flag. The OVP output in the LX1665 & LX1665A can be used to drive an SCR crowbar circuit to protect the load in the event of a short-circuit of the main MOSFET. The LX1665 & LX1665A also have a logic-level Power Good Flag to signal when the output voltage is out of specified limits.

DEVICE SELECTION GUIDE

DEVICE	Packages	OVP and Power Good	Current-Sense Comp. Thresh. (mV)	Optimal Load
LX1664	16-pin SOIC	No	100	Pentium-class (<10A)
LX1664A	& DIP		60	Pentium II (> 10A)
LX1665	18-pin SOIC	Yes	100	Pentium-class (<10A)
LX1665A	& DIP		60	Pentium II (> 10A)

ABSOLUTE MAXIMUM RATINGS (Note 1)

Supply Voltage (V_{C1})	25V
Supply Voltage (V_{CC})	15V
Output Drive Peak Current Source (500ns)	1.5A
Output Drive Peak Current Sink (500ns)	1.5A
Input Voltage (SS, INV, $V_{CC,CORE}$, C_T , VID0-VID4)	-0.3V to 6V
Operating Junction Temperature	
Plastic (N, D & DW Packages)	150°C
Storage Temperature Range	-65°C to +150°C
Lead Temperature (Soldering, 10 Seconds)	300°C

Note 1. Exceeding these ratings could cause damage to the device. All voltages are with respect to Ground. Currents are positive into, negative out of the specified terminal. Pin numbers refer to DIL packages only.

THERMAL DATA

N (16-PIN DIP) PACKAGE:

THERMAL RESISTANCE-JUNCTION TO AMBIENT, θ_{JA}	65°C/W
-------------------------------------------------------	--------

N (18-PIN DIP) PACKAGE:

THERMAL RESISTANCE-JUNCTION TO AMBIENT, θ_{JA}	60°C/W
-------------------------------------------------------	--------

D PACKAGE:

THERMAL RESISTANCE-JUNCTION TO AMBIENT, θ_{JA}	120°C/W
-------------------------------------------------------	---------

DW PACKAGE:

THERMAL RESISTANCE-JUNCTION TO AMBIENT, θ_{JA}	90°C/W
-------------------------------------------------------	--------

Junction Temperature Calculation: $T_J = T_A + (P_D \times \theta_{JA})$.

The θ_{JA} numbers are guidelines for the thermal performance of the device/pc-board system.

All of the above assume no ambient airflow

PACKAGE PIN OUTS

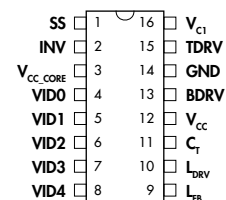

N PACKAGE — 16-Pin
LX1664/1664A (Top View)

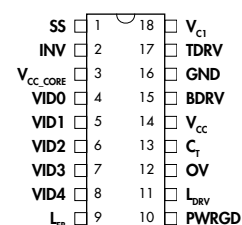

N PACKAGE — 18-Pin
LX1665/1665A (Top View)

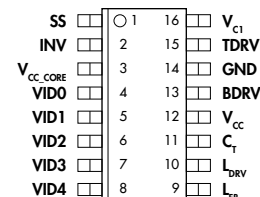

D PACKAGE — 16-Pin
LX1664/1664A (Top View)

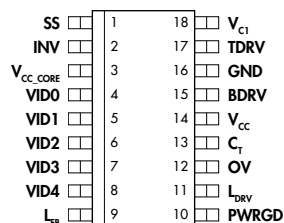

DW PACKAGE — 18-Pin
LX1665/1665A (Top View)

LX1664/1664A, LX1665/65A

DUAL OUTPUT PWM CONTROLLERS WITH 5-BIT DAC

PRODUCTION DATA SHEET

ELECTRICAL CHARACTERISTICS

(Unless otherwise specified, $10.8 < V_{CC} < 13.2$, $0^{\circ}\text{C} \leq T_A \leq 70^{\circ}\text{C}$. Test conditions: $V_{CC} = 12\text{V}$, $T = 25^{\circ}\text{C}$. Use Application Circuit.)

Parameter	Symbol	Test Conditions	LX1664/1665 (A)			Units	
			Min.	Typ.	Max.		
Reference & DAC Section (See Table 1 - Next Page)							
Regulation Accuracy (See Table 1)		(Less 40mV output adaptive positioning), $V_{CC} = 12\text{V}$, $I_{LOAD} = 6\text{A}$	-30		30	mV	
Regulation Accuracy		$1.8\text{V} \leq V_{OUT} \leq 2.8\text{V}$	-1		1	%	
Timing Section							
Off Time Initial	OT	$V_{CC_CORE} = 1.3\text{V}$, $C_T = 390\text{pF}$		2		μs	
		$V_{CC_CORE} = 3.5\text{V}$, $C_T = 390\text{pF}$		1		μs	
Off Time Temp Stability		$V_{CC_CORE} = 1.3\text{V}$ to 3.5V		40		ppm	
Discharging Current	I_{DIS}	$V_{CC_CORE} = 1.3\text{V}$, $V_{CT} = 1.5\text{V}$	180	210	240	μA	
Ramp Peak	V_P			2		V	
Ramp Peak-Valley	V_{RPP}	$V_{CC_CORE} = 1.3\text{V}$	0.9	1	1.1	V	
		$V_{CC_CORE} = 3.5\text{V}$	0.37	0.42	0.47	V	
Ramp Valley Delay to Output		10% Overdrive		100		ns	
Error Comparator Section							
Input Bias Current	I_B	$1.3\text{V} < V_{SS} = V_{INV} < 3.5\text{V}$		0.8	2	μA	
Input Offset Voltage	V_{IO}		36	41	46	mV	
E_c Delay to Output		10% Overdrive		200		ns	
Current Sense Section							
Input Bias Current (V_{CC_CORE} Pin)	I_B	$1.3\text{V} < V_{INV} = V_{CC_CORE} < 3.5\text{V}$		27	35	μA	
Pulse By Pulse C_L	V_{CLP}	LX1664/1665	Initial Accuracy	85	100	115	mV
		LX1664A/1665A	Initial Accuracy	50	60	70	mV
C_s Delay to Output		10% Overdrive		200		ns	
Output Drivers Section							
Drive Rise Time	T_R	$V_{C1} = V_{CC} = 12\text{V}$, $C_L = 3000\text{pF}$		70		ns	
Drive Fall Time	T_F	$V_{C1} = V_{CC} = 12\text{V}$, $C_L = 3000\text{pF}$		70		ns	
Drive High	V_{DH}	$V_{CC} = V_{CC} = 12\text{V}$, $I_{SOURCE} = 20\text{mA}$		11		V	
		$V_{CC} = V_{CC} = 12\text{V}$, $I_{SINK} = 200\text{mA}$		10		V	
Drive Low	V_{DL}	$V_{CC} = V_{CC} = 12\text{V}$, $I_{SOURCE} = 20\text{mA}$		0.06	0.1	V	
		$V_{CC} = V_{CC} = 12\text{V}$, $I_{SINK} = 200\text{mA}$		0.8	1.2	V	
Output Pull Down	V_{PD}	$V_{CC} = V_c = 0$, $I_{PULLUP} = 2\text{mA}$		0.8	1.4	V	
UVLO and S.S. Section							
Start-Up Threshold	V_{ST}		9.9	10.1	10.4	V	
Hysteresis	V_{HYST}			0.31		V	
SS Sink Current	I_{SD}	$V_{C1} = 10.1\text{V}$	2	5.5		mA	
SS Sat Voltage	V_{OL}	$V_{C1} = 9\text{V}$, $I_{SD} = 200\mu\text{A}$		0.15	0.6	V	
Supply Current Section							
Dynamic Operating Current	I_{CD}	$V_{CC} = V_{C1} = 12\text{V}$, Out Freq = 200kHz, $C_L = 0$			27	mA	
Power Good / Over-Voltage Protection Section (LX1665 Only)							
Lower Threshold		$(V_{CC_CORE} / \text{DAC}_{OUT})$	88	90	92	%	
Hysteresis				1		%	
Power Good Voltage Low		$I_{PWRGD} = 5\text{mA}$		0.5	0.7	V	
Over-Voltage Threshold		(V_{CC_CORE} / V_{DAC})	110	117	125	%	
OVP Sourcing Current		$V_{OV} = 5\text{V}$	30	45		mA	
Linear Regulator Section							
Output Voltage		Set by external resistors	1.5		3.6	V	
Setpoint Accuracy		$I_L = 0.5\text{A}$ using 0.5% resistors	-1.5		1.5	%	
Output Temperature Drift				40		ppm	
Load Regulation					1.5	%	
Cummulative Accuracy					3	%	
Op-Amp Output Current		Open Loop	50	70		mA	

LX1664/64A, LX1665/65A

DUAL OUTPUT PWM CONTROLLERS WITH 5-BIT DAC

PRODUCTION DATA SHEET

ELECTRICAL CHARACTERISTICS

Table 1 - Adaptive Transient Voltage Output (Output Voltage Setpoint — Typical)

Processor Pins 0 = Ground, 1 = Open (Floating)					Output Voltage (V_{CC_CORE})	
VID4	VID3	VID2	VID1	VID0	0.0A	Nominal Output*
0	1	1	1	1	1.34V	1.30V
0	1	1	1	0	1.39V	1.35V
0	1	1	0	1	1.44V	1.40V
0	1	1	0	0	1.49V	1.45V
0	1	0	1	1	1.54V	1.50V
0	1	0	1	0	1.59V	1.55V
0	1	0	0	1	1.64V	1.60V
0	1	0	0	0	1.69V	1.65V
0	0	1	1	1	1.74V	1.70V
0	0	1	1	0	1.79V	1.75V
0	0	1	0	1	1.84V	1.80V
0	0	1	0	0	1.89V	1.85V
0	0	0	1	1	1.94V	1.90V
0	0	0	1	0	1.99V	1.95V
0	0	0	0	1	2.04V	2.00V
0	0	0	0	0	2.09V	2.05V
1	1	1	1	1	2.04V	2.00V
1	1	1	1	0	2.14V	2.10V
1	1	1	0	1	2.24V	2.20V
1	1	1	0	0	2.34V	2.30V
1	1	0	1	1	2.44V	2.40V
1	1	0	1	0	2.54V	2.50V
1	1	0	0	1	2.64V	2.60V
1	1	0	0	0	2.74V	2.70V
1	0	1	1	1	2.84V	2.80V
1	0	1	1	0	2.94V	2.90V
1	0	1	0	1	3.04V	3.00V
1	0	1	0	0	3.14V	3.10V
1	0	0	1	1	3.24V	3.20V
1	0	0	1	0	3.34V	3.30V
1	0	0	0	1	3.44V	3.40V
1	0	0	0	0	3.54V	3.50V

* Nominal = DAC setpoint voltage with no adaptive output voltage positioning.

Note:

Adaptive Transient Voltage Output

In order to improve transient response a 40mV offset is built into the Current Sense comparator. At high currents, the peak output voltage will be lower than the nominal set point, as shown in Figure 1. The actual output voltage will be a function of the sense resistor, the output current and output ripple.

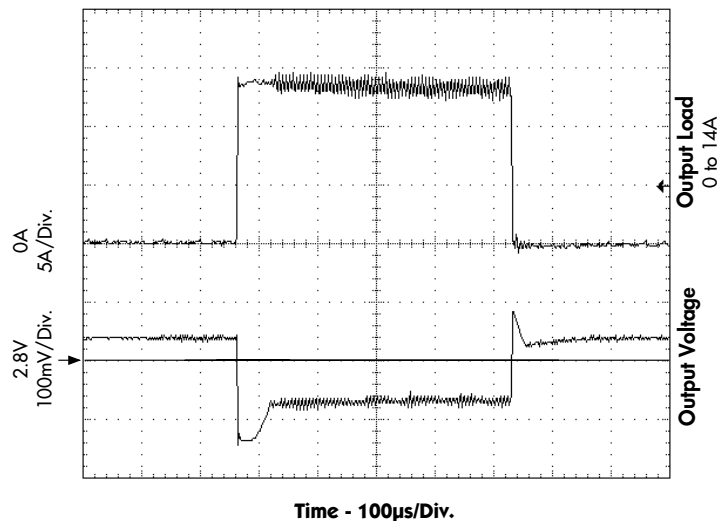

FIGURE 1 — Output Transient Response
(using 5mΩ sense resistor and 5µH output inductor)

LX1664/1664A, LX1665/65A

DUAL OUTPUT PWM CONTROLLERS WITH 5-BIT DAC

PRODUCTION DATA SHEET

CHARACTERISTICS CURVES

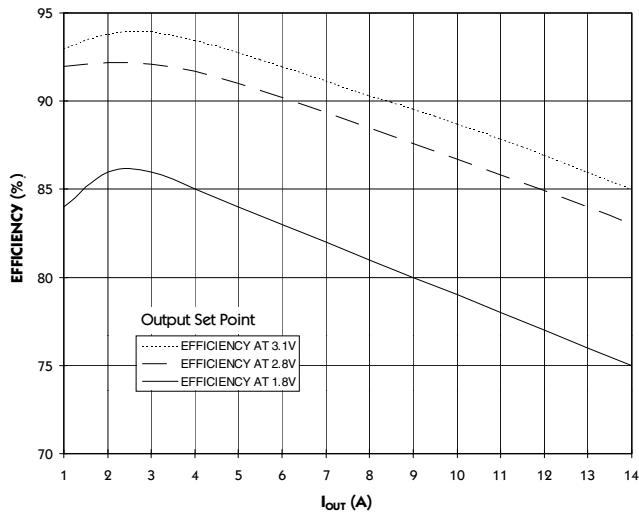

FIGURE 2 — Efficiency Test Results:
Non-Synchronous Operation, $V_{IN} = 5V$

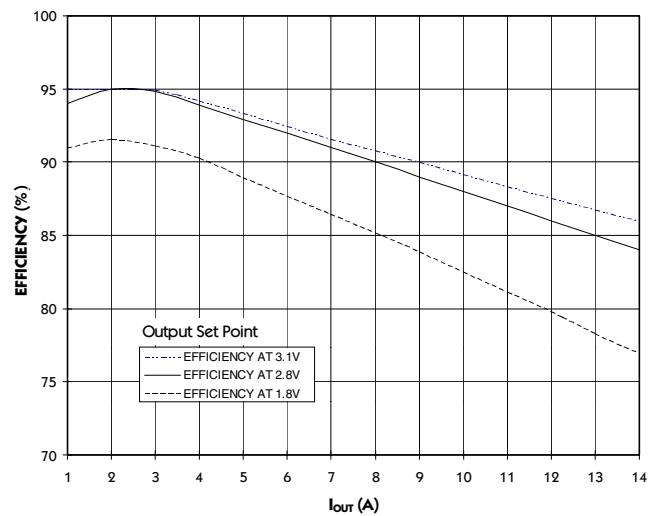

FIGURE 3 — Efficiency Test Results:
Synchronous Operation, $V_{IN} = 5V$

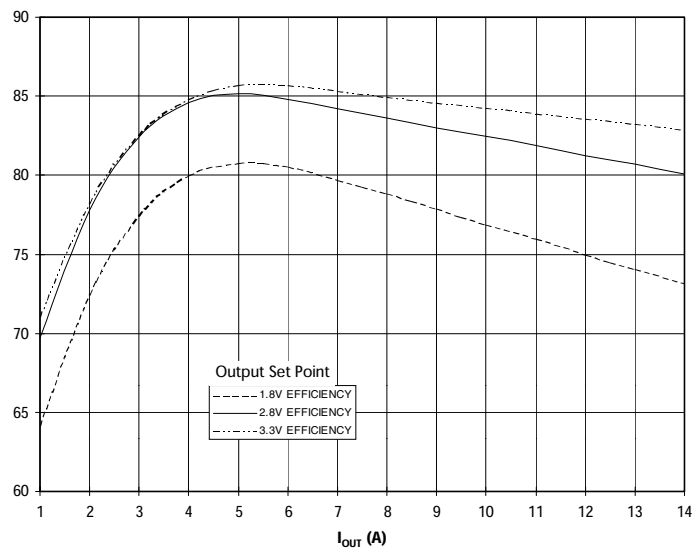

FIGURE 4 — Efficiency Test Results: Synchronous Operation, $V_{IN} = 12V$.

Note: Non-synchronous operation not recommended for 12V operation, due to power loss in Schottky diode.

LX1664/64A, LX1665/65A

DUAL OUTPUT PWM CONTROLLERS WITH 5-BIT DAC

PRODUCTION DATA SHEET

BLOCK DIAGRAM

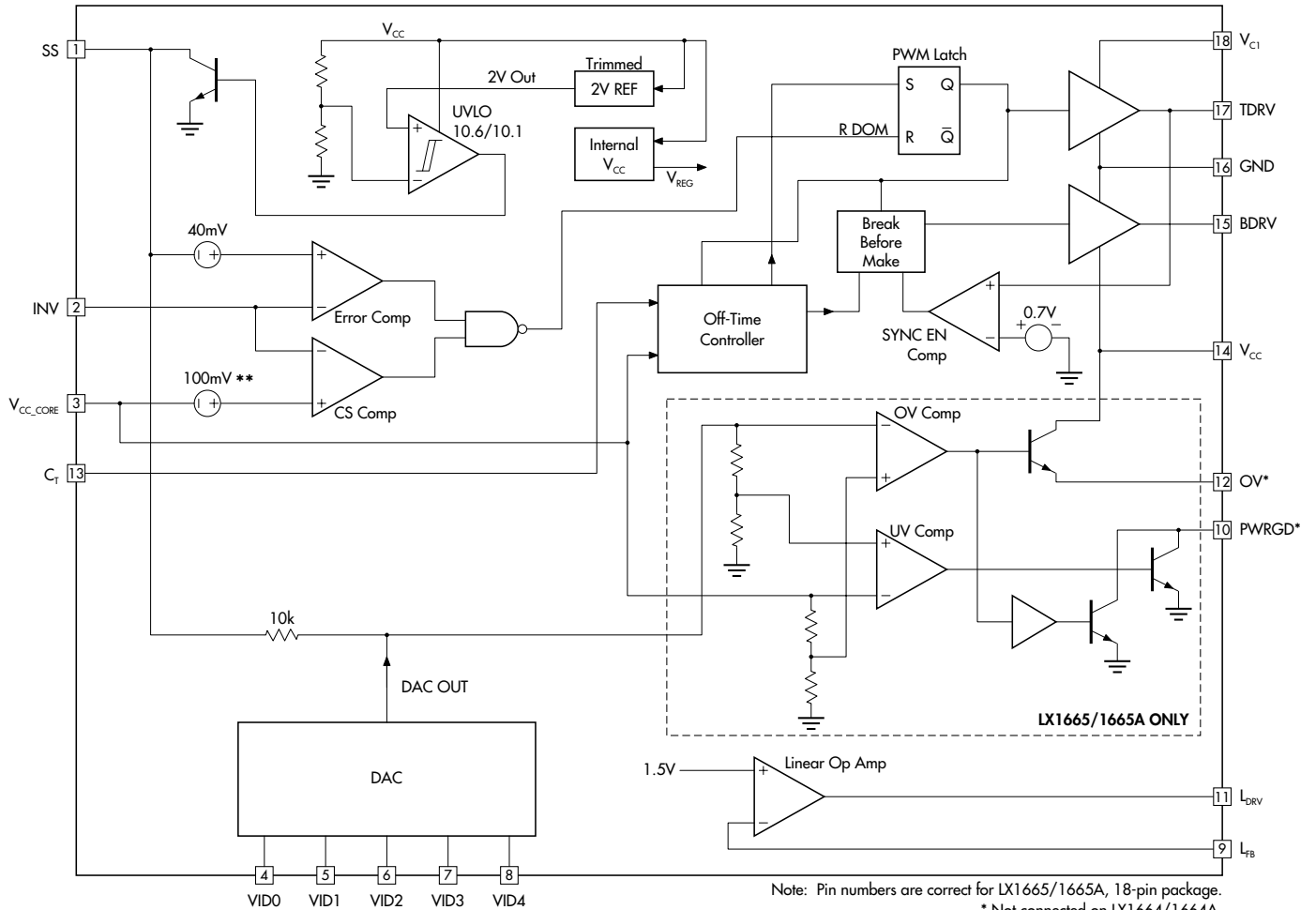

FIGURE 5 — LX1664/1665 Block Diagram

LX1664/1664A, LX1665/65A

DUAL OUTPUT PWM CONTROLLERS WITH 5-BIT DAC

PRODUCTION DATA SHEET

FUNCTIONAL PIN DESCRIPTION

Pin Name	LX1664 Pin #	LX1665 Pin #	Description
SS	1	1	Soft-Start pin, internally connected to the non-inverting input of the error comparator.
INV	2	2	Inverting input of the error comparator.
V _{CC_CORE}	3	3	Output voltage. Connected to non-inverting input of the current-sense comparator.
VID0	4	4	Voltage Identification pin (LSB) input used to set output voltage.
VID1	5	5	Voltage Identification pin (2 nd SB) input.
VID2	6	6	Voltage Identification pin (3 rd SB) input.
VID3	7	7	Voltage Identification pin (4 th SB) input.
VID4	8	8	Voltage Identification pin (MSB) input. This pin is also the range select pin — when low (CLOSED), output voltage is set to between 1.30 and 2.05V in 0.05V increments. When high (OPEN), output is adjusted from 2.0 to 3.5V in 0.1V increments.
L _{FB}	9	9	Linear regulator feedback pin. 1.5V reference is connected to a resistor divider to set desired output voltage.
PWRGD	N.C.	10	Open collector output pulls low when the output voltage is out of limits.
L _{DRV}	10	11	Linear regulator drive pin. Connect to gate of MOSFET for linear regulator function.
OV	N.C.	12	SCR driver goes high when the processor's supply is over specified voltage limits.
C _T	11	13	The off-time is programmed by connecting a timing capacitor to this pin.
V _{CC}	12	14	This is the (12V) supply to the IC, as well as gate drive to the bottom FET.
BDRV	13	15	This is the gate drive to the bottom FET. Leave open in non-synchronous operation (when bottom FET is replaced by a Schottky diode).
GND	14	16	Both power and signal ground of the device.
TDRV	15	17	Gate drive for top MOSFET.
V _{C1}	16	18	This pin is a separate power supply input for the top drive. Can be connected to a charge pump when only 12V is available.

LX1664/64A, LX1665/65A

DUAL OUTPUT PWM CONTROLLERS WITH 5-BIT DAC

PRODUCTION DATA SHEET

THEORY OF OPERATION

IC OPERATION

Referring to the block diagram and typical application circuit, the output turns ON the top MOSFET, allowing the inductor current to increase. At the error comparator threshold, the PWM latch is reset, the top MOSFET turns OFF and the synchronous MOSFET turns ON. The OFF-time capacitor C_T is now allowed to discharge. At the valley voltage, the synchronous MOSFET turns OFF and the top MOSFET turns on. A special break-before-make circuit prevents simultaneous conduction of the two MOSFETS.

The $V_{CC,CORE}$ pin is offset by +40mV to enhance transient response. The INV pin is connected to the positive side of the current sense resistor, so the controller regulates the positive side of the sense resistor. At light loads, the output voltage will be regulated above the nominal setpoint voltage. At heavy loads, the output voltage will drop below the nominal setpoint voltage. To minimize frequency variation with varying output voltage, the OFF-time is modulated as a function of the voltage at the $V_{CC,CORE}$ pin.

ERROR VOLTAGE COMPARATOR

The error voltage comparator compares the voltage at the positive side of the sense resistor to the set voltage plus 40mV. An external filter is recommended for high-frequency noise.

CURRENT LIMIT

Current limiting is done by sensing the inductor current. Exceeding the current sense threshold turns the output drive OFF and latches it OFF until the PWM latch Set input goes high again. See Current Limit Section in "Using The LX1664/65 Devices" later in this data sheet.

OFF-TIME CONTROL TIMING

The timing capacitor C_T allows programming of the OFF-time. The timing capacitor is quickly charged during the ON time of the top MOSFET and allowed to discharge when the top MOSFET is OFF. In order to minimize frequency variations while providing different supply voltages, the discharge current is modulated by the voltage at the $V_{CC,CORE}$ pin. The OFF-time is inversely proportional to the $V_{CC,CORE}$ voltage.

UNDER VOLTAGE LOCKOUT

The purpose of the UVLO is to keep the output drive off until the input voltage reaches the start-up threshold. At voltages below the start-up voltage, the UVLO comparator disables the internal biasing, and turns off the output drives. The SS (Soft-Start) pin is pulled low.

SYNCHRONOUS CONTROL

The synchronous control section incorporates a unique break-before-make function to ensure that the primary switch and the synchronous switch are not turned on at the same time. Approximately 100 nanoseconds of deadtime is provided by the break-before-make circuitry to protect the MOSFET switches.

PROGRAMMING THE OUTPUT VOLTAGE

The output voltage is set by means of a 5-bit digital Voltage Identification (VID) word (See Table 1). The VID code may be hard-wired into the package of the processor which do not have a VID code, the output voltage can be set by means of a DIP switch or jumpers. For a low or '0' signal, connect the VID pin to ground (DIP switch ON); for a high or '1' signal, leave the VID pin open (DIP switch OFF).

The five VID pins on the LX166x series are designed to interface directly with a Pentium Pro or Pentium II processor. Therefore, all inputs are expected to be either ground or floating. Any floating input will be pulled high by internal connections. If using a Socket 7 processor, or other load, the VID code can be set directly by connecting jumpers or DIP switches to the VID[0:4] pins.

The VID pins **are not designed to take TTL inputs, and should not be connected high**. Unpredictable output voltages may result. If the LX166x devices are to be connected to a logic circuit, such as BIOS, for programming of output voltage, they should be buffered using a CMOS gate with open-drain, such as a 74HC125 or 74C906.

POWER GOOD SIGNAL (LX1665 only)

An open collector output is provided which presents high impedance when the output voltage is between 90% and 117% of the programmed VID voltage, measured at the SS pin. Outside this window the output presents a low impedance path to ground. The Power Good function also toggles low during OVP operation.

OVER-VOLTAGE PROTECTION

The controller is inherently protected from an over-voltage condition due to its constant OFF-time architecture. However, should a failure occur at the power switch, an over-voltage drive pin is provided (on the LX1665 only) which can drive an external SCR crowbar (Q_3), and so blow a fuse (F_1). The fault condition must be removed and power recycled for the LX1665 to resume normal operation (See Figure 9).

LINEAR REGULATOR

The product highlight application shows an application schematic using a MOSFET as the pass element for a linear regulator. This output is suitable for converting the 5V system supply to 3.3V for processor I/O buffers, memory, chipset and other components. The output can be adjusted to any voltage between 1.5V and 3.6V in order to supply other (lower) power requirements on a motherboard. See section "Using the LX1664/1665 Devices" at the end of this data sheet.

LX1664/1664A, LX1665/65A

DUAL OUTPUT PWM CONTROLLERS WITH 5-BIT DAC

PRODUCTION DATA SHEET

APPLICATION INFORMATION

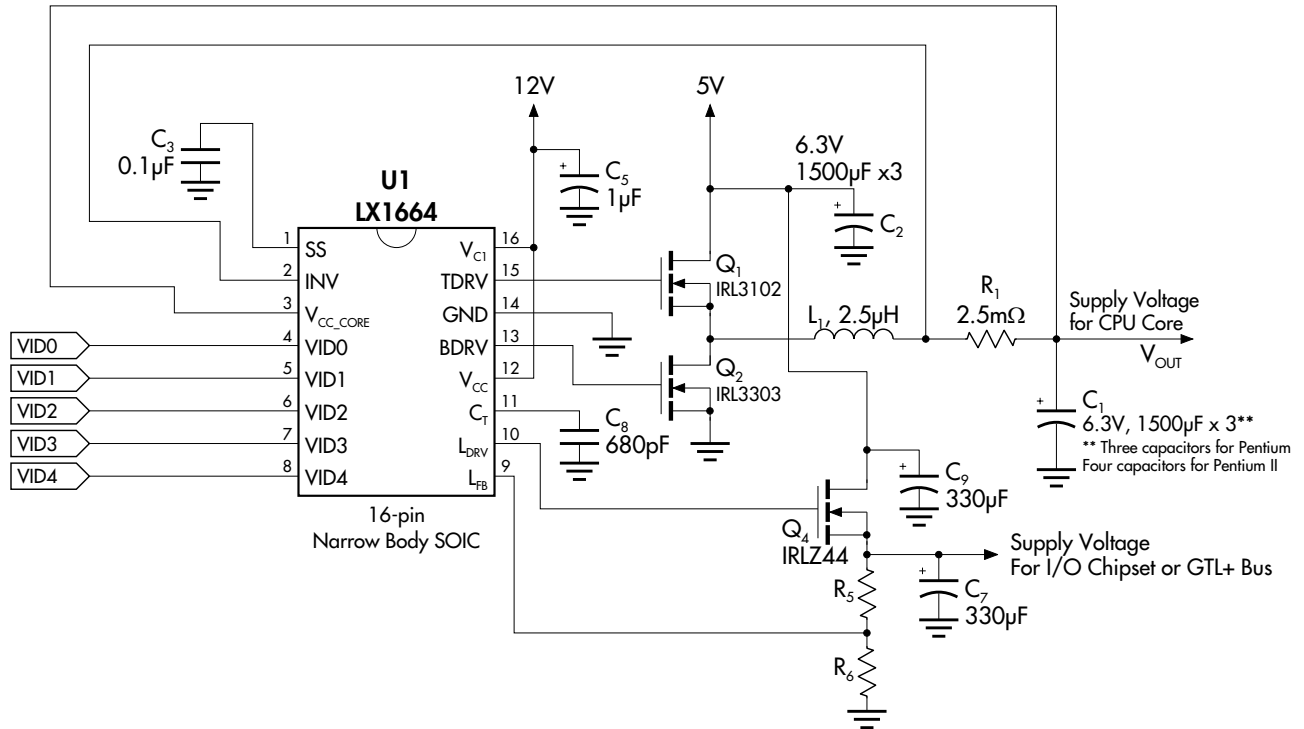

FIGURE 6 — LX1664 In A Pentium / Socket 7 Single-Chip Power Supply Controller Solution (Synchronous)

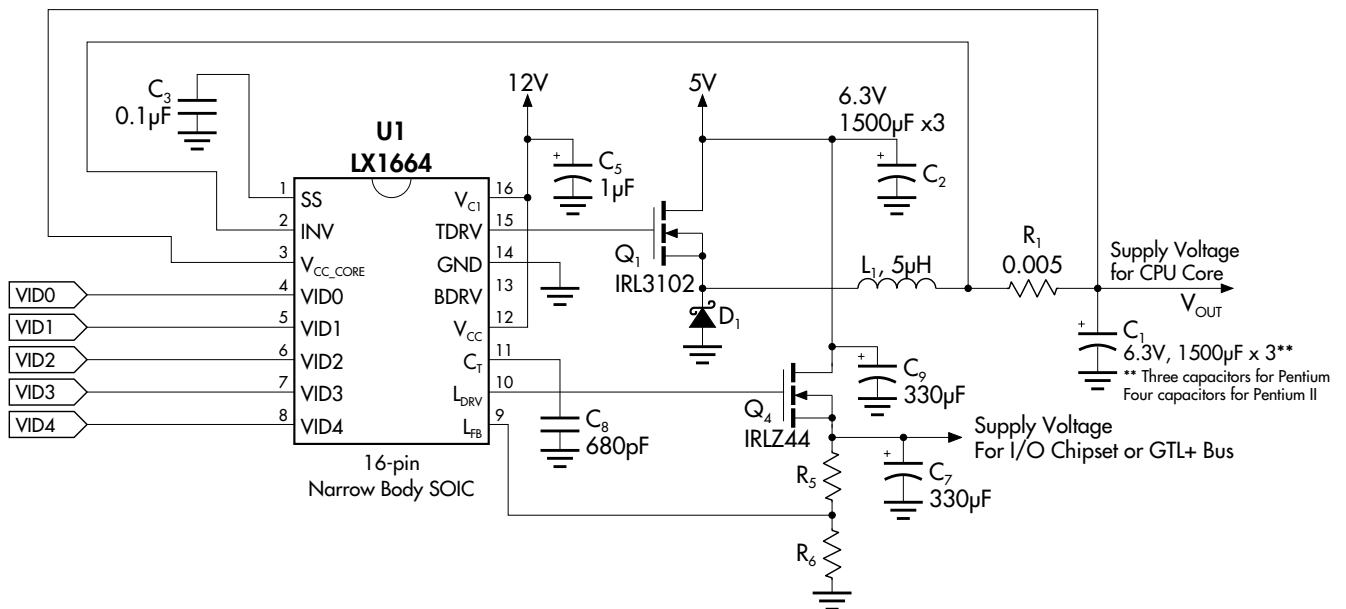

FIGURE 7 — LX1664 In A Non-Synchronous / Socket 7 Power Supply Application

LX1664/1664A, LX1665/65A

DUAL OUTPUT PWM CONTROLLERS WITH 5-BIT DAC

PRODUCTION DATA SHEET

BILL OF MATERIALS

LX1665 Bill of Materials (Refer to Product Highlight)

Ref	Description	Part Number / Manufacturer	Qty.
C ₁	1500µF, 6.3V capacitor	MV-GX Sanyo	4
C ₂	1500µF, 6.3V capacitor	MV-GX Sanyo	2
C ₇ , C ₉	330µF, Electrolytic	MV-GX Sanyo	2
C ₃	0.1µF	SMD Cap	1
C ₄	390pF	SMD Cap	1
C ₈	680pF	SMD Cap	1
C ₅	1µF, 16V	SMD Ceramic	1
L ₁	2.5µH Inductor	HM0096832 BI or equivalent	1
L ₂	1µH Inductor		1
Q ₁	MOSFET	IRL3102 International Rectifier or equivalent	1
Q ₂	MOSFET	IRL3303 International Rectifier or equivalent	1
Q ₃	MOSFET	IRLZ44 International Rectifier or equivalent	1
R ₅ , R ₆	Resistor (See Table 6 for values)	SMD Resistor	2
R ₁	2.5mΩ Sense Resistor	IRC OARS-1 or PCB trace	1
U1	Controller IC	LX1665CDW Linfinity	1
Total			21

USING THE LX1664/65 DEVICES

The LX1664/65 devices are very easy to design with, requiring only a few simple calculations to implement a given design. The following procedures and considerations should provide effective operation for virtually all applications. Refer to the **Application Information** section for component reference designators.

TIMING CAPACITOR SELECTION

The frequency of operation of the LX166x is a function of duty cycle and OFF-time. The OFF-time is proportional to the timing capacitor (which is shown as C₈ in all application schematics in this data sheet), and is modulated to minimize frequency variations with duty cycle. The frequency is constant, during steady-state operation, due to the modulation of the OFF-time.

The timing capacitor (C_T) should be selected using the following equation:

$$C_T = \frac{(1 - V_{OUT}/V_{IN}) * I_{DIS}}{f_s (1.52 - 0.29 * V_{OUT})}$$

Where I_{DIS} is fixed at 200µA and f_s is the switching frequency (recommended to be around 200kHz for optimal operation and component selection).

When using a 5V input voltage, the switching frequency (f_s) can be approximated as follows:

$$C_T = 0.621 * \frac{I_{DIS}}{f_s}$$

Choosing a 680pF capacitor will result in an operating frequency of 183kHz at V_{OUT} = 2.8V. When a 12V power input is used, the capacitor value must be changed (the optimal timing capacitor for 12V input will be in the range of 1000-1500pF).

L₁ OUTPUT INDUCTOR SELECTION

The inductance value chosen determines the ripple current present at the output of the power supply. Size the inductance to allow a nominal ±10% swing above and below the nominal DC load current, using the equation L = V_L * ΔT/ΔI, where ΔT is the OFF-time, V_L is the voltage across the inductor during the OFF-time, and ΔI is peak-to-peak ripple current in the inductor. Be sure to select a high-frequency core material which can handle the DC current, such as 3C8, which is sized for the correct power level. Typical inductance values can range from 2 to 10µH.

Note that ripple current will increase with a smaller inductor. Exceeding the ripple current rating of the capacitors could cause reliability problems.

LX1664/64A, LX1665/65A

DUAL OUTPUT PWM CONTROLLERS WITH 5-BIT DAC

PRODUCTION DATA SHEET

USING THE LX1664/65 DEVICES

INPUT INDUCTOR SELECTION

In order to cope with faster transient load changes, a smaller output inductor is needed. However, reducing the size of the output inductor will result in a higher ripple voltage on the input supply. This noise on the 5V rail can affect other loads, such as graphics cards. It is recommended that a smaller input inductor, L_2 (1 - 1.5 μ H), is used on the 5V rail to filter out the ripple. Ensure that this inductor has the same current rating as the output inductor.

C₁ FILTER CAPACITOR SELECTION

The capacitors on the output of the PWM section are used to filter the output current ripple, as well as help during transient load conditions, and the capacitor bank should be sized to meet ripple and transient performance specifications.

When a transient (step) load current change occurs, the output voltage will have a step which equals the product of the Effective Series Resistance (ESR) of the capacitor and the current step (ΔI). when current increases from low (in sleep mode) to high, the output voltage will drop below its steady state value. In the advanced microprocessor power supply, the capacitor should usually be selected on the basis of its ESR value, rather than the capacitance or RMS current capability. Capacitors that satisfy the ESR requirement usually have a larger capacitance and current capability than needed for the application. The allowable ESR can be found by:

$$ESR * (I_{RIPPLE} + \Delta I) < V_{EX}$$

Where V_{EX} is the allowable output voltage excursion in the transient and I_{RIPPLE} is the inductor ripple current. Regulators such as the LX166x series, have adaptive output voltage positioning, which adds 40mV to the DC set-point voltage — V_{EX} is therefore the difference between the low load voltage and the minimum dynamic voltage allowed for the microprocessor.

Ripple current is a function of the output inductor value (L_{OUT}), and can be approximated as follows:

$$I_{RIPPLE} = \frac{V_{IN} - V_{OUT}}{f_s * L_{OUT}} * \frac{V_{OUT}}{V_{IN}}$$

Where f_s is the switching frequency.

Electrolytic capacitors can be used for the output filter capacitor bank, but are less stable with age than tantalum capacitors. As they age, their ESR degrades, reducing the system performance and increasing the risk of failure. It is recommended that multiple parallel capacitors are used so that, as ESR increases with age, overall performance will still meet the processor's requirements.

There is frequently strong pressure to use the least expensive components possible, however, this could lead to degraded long-term reliability, especially in the case of filter capacitors. LInfinity's demo boards use Sanyo MV-GX filter capacitors, which are

C₁ FILTER CAPACITOR SELECTION (continued)

aluminum electrolytic, and have demonstrated reliability. The Oscon series from Sanyo generally provides the very best performance in terms of long term ESR stability and general reliability, but at a substantial cost penalty. The MV-GX series provides excellent ESR performance, meeting all Intel transient specifications, at a reasonable cost. Beware of off-brand, very-low cost filter capacitors, which have been shown to degrade in both ESR and general electrolyte characteristics over time.

CURRENT LIMIT

Current limiting occurs when a sensed voltage, proportional to load current, exceeds the current-sense comparator threshold value. The current can be sensed either by using a fixed sense resistor in series with the inductor to cause a voltage drop proportional to current, or by using a resistor and capacitor in parallel with the inductor to sense the voltage drop across the parasitic resistance of the inductor.

The LX166x family offers two different comparator thresholds. The LX1664 & 1665 have a threshold of 100mV, while the LX1664A and LX1665A have a threshold of 60mV. The 60mV threshold is better suited to higher current loads, such as a Pentium II or Deschutes processor.

Sense Resistor

The current sense resistor, R_1 , is selected according to the formula:

$$R_1 = V_{TRIP} / I_{TRIP}$$

Where V_{TRIP} is the current sense comparator threshold (100mV for LX1664/65 and 60mV for LX1664A/65A) and I_{TRIP} is the desired current limit. Typical choices are shown below.

TABLE 2 - Current Sense Resistor Selection Guide

Load	Sense Resistor Value	Recommended Controller
Pentium-Class Processor (<10A)	5m Ω	LX1664 or LX1665
Pentium II Class (>10A)	2.5m Ω	LX1664A or LX1665A

A smaller sense resistor will result in lower heat dissipation (I^2R) and also a smaller output voltage droop at higher currents.

There are several alternative types of sense resistor. The surface-mount metal "staple" form of resistor has the advantage of exposure to free air to dissipate heat and its value can be controlled very tightly. Its main drawback, however, is cost. An alternative is to construct the sense resistor using a copper PCB trace. Although the resistance cannot be controlled as tightly, the PCB trace is very low cost.

USING THE LX1664/65 DEVICES

CURRENT LIMIT (continued)

PCB Sense Resistor

A PCB sense resistor should be constructed as shown in Figure 10. By attaching directly to the large pads for the capacitor and inductor, heat is dissipated efficiently by the larger copper masses. Connect the current sense lines as shown to avoid any errors.

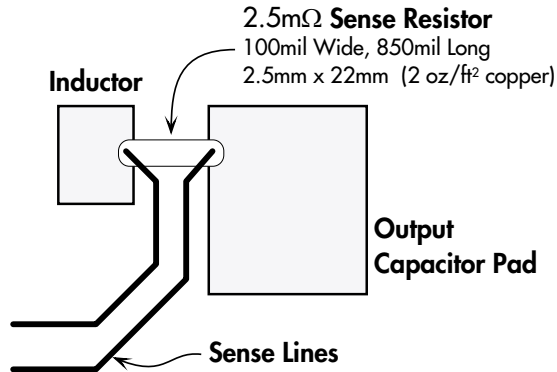

FIGURE 10 — Sense Resistor Construction Diagram

Recommended sense resistor sizes are given in the following table:

TABLE 3 - PCB Sense Resistor Selection Guide

Copper Weight	Copper Thickness	Desired Resistor Value	Dimensions (w x l)	
			mm	inches
2 oz/ft ²	68µm	2.5mΩ	2.5 x 22	0.1 x 0.85
		5mΩ	2.5 x 43	0.1 x 1.7

Loss-Less Current Sensing Using Resistance of Inductor

Any inductor has a parasitic resistance, R_L , which causes a DC voltage drop when current flows through the inductor. Figure 11 shows a sensor circuit comprising of a surface mount resistor, R_S , and capacitor, C_S , in parallel with the inductor, eliminating the current sense resistor.

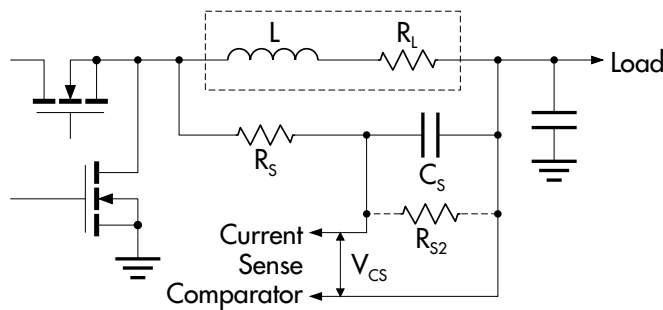

FIGURE 11 — Current Sense Circuit

CURRENT LIMIT (continued)

The current flowing through the inductor is a triangle wave. If the sensor components are selected such that:

$$L/R_L = R_S * C_S$$

The voltage across the capacitor will be equal to the current flowing through the resistor, i.e.

$$V_{CS} = I_L R_L$$

Since V_{CS} reflects the inductor current, by selecting the appropriate R_S and C_S , V_{CS} can be made to reach the comparator voltage (60mV for LX166xA or 100mV for the LX166x) at the desired trip current.

Design Example

(Pentium II circuit, with a maximum static current of 14.2A)

The gain of the sensor can be characterized as:

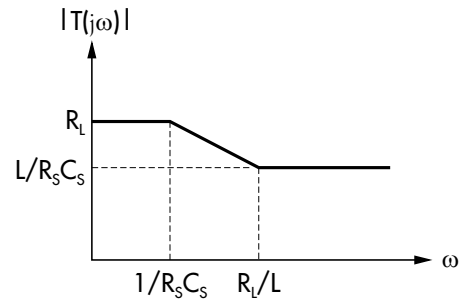

FIGURE 12 — Sensor Gain

The dc/static tripping current $I_{trip,s}$ satisfies:

$$I_{trip,s} = \frac{V_{trip}}{R_L}$$

Select $L/R_S C_S \leq R_L$ to have higher dynamic tripping current than the static one. The dynamic tripping current $I_{trip,d}$ satisfies:

$$I_{trip,d} = \frac{V_{trip}}{L/(R_S C_S)}$$

General Guidelines for Selecting R_S , C_S , and R_L

$$R_L = \frac{V_{trip}}{I_{trip,s}} \quad \text{Select: } R_S \leq 10 \text{ k}\Omega$$

$$\text{and } C_S \text{ according to: } C_{Sn} = \frac{L_n}{R_L R_S}$$

The above equation has taken into account the current-dependency of the inductance.

The test circuit (Figure 6) used the following parameters: $R_L = 3\text{m}\Omega$, $R_S = 9\text{k}\Omega$, $C_S = 0.1\mu\text{F}$, and L is $2.5\mu\text{H}$ at 0A current.

USING THE LX1664/65 DEVICES

CURRENT LIMIT (continued)

In cases where R_L is so large that the trip point current would be lower than the desired short-circuit current limit, a resistor (R_{S2}) can be put in parallel with C_S , as shown in Figure 11. The selection of components is as follows:

$$\frac{R_{L(Required)}}{R_{L(Actual)}} = \frac{R_{S2}}{R_{S2} + R_S}$$

$$C_S = \frac{L}{R_{L(Actual)} * (R_{S2} // R_S)} = \frac{L}{R_{L(Actual)}} * \frac{R_S + R_{S2}}{R_{S2} * R_S}$$

Again, select $(R_{S2} // R_S) < 10k\Omega$.

FET SELECTION

To insure reliable operation, the operating junction temperature of the FET switches must be kept below certain limits. The Intel specification states that 115°C maximum junction temperature should be maintained with an ambient of 50°C. This is achieved by properly derating the part, and by adequate heat sinking. One of the most critical parameters for FET selection is the $R_{DS(ON)}$ resistance. This parameter directly contributes to the power dissipation of the FET devices, and thus impacts heat sink design, mechanical layout, and reliability. In general, the larger the current handling capability of the FET, the lower the $R_{DS(ON)}$ will be, since more die area is available.

TABLE 4 - FET Selection Guide

This table gives selection of suitable FETs from International Rectifier.

Device	$R_{DS(ON)}$ @ 10V (mΩ)	I_D @ $T_C = 100^\circ\text{C}$	Max. Break-down Voltage
IRL3803	6	83	30
IRL22203N	7	71	30
IRL3103	14	40	30
IRL3102	13	56	20
IRL3303	26	24	30
IRL2703	40	17	30

All devices in TO-220 package. For surface mount devices (TO-263 / D²-Pak), add 'S' to part number, e.g. IRL3103S.

The recommended solution is to use IRL3102 for the high side and IRL3303 for the low side FET, for the best combination of cost and performance. Alternative FET's from any manufacturer could be used, provided they meet the same criteria for $R_{DS(ON)}$.

Heat Dissipated In Upper MOSFET

The heat dissipated in the top MOSFET will be:

$$P_D = (I^2 * R_{DS(ON)} * Duty Cycle) + (0.51 * V_{IN} * t_{SW} * f_s)$$

Where t_{SW} is switching transition time for body diode (~100ns) and f_s is the switching frequency.

FET SELECTION (continued)

For the IRL3102 ($13m\Omega R_{DS(ON)}$), converting 5V to 2.8V at 14A will result in typical heat dissipation of 1.48W.

Synchronous Rectification – Lower MOSFET

The lower pass element can be either a MOSFET or a Schottky diode. The use of a MOSFET (synchronous rectification) will result in higher efficiency, but at higher cost than using a Schottky diode (non-synchronous).

Power dissipated in the bottom MOSFET will be:

$$P_D = I^2 * R_{DS(ON)} * [1 - Duty Cycle] = 2.24W$$

(IRL3303 or 1.12W for the IRL3102)

Catch Diode – Lower MOSFET

A low-power Schottky diode, such as a 1N5817, is recommended to be connected between the gate and source of the lower MOSFET when operating from a 12V-power supply (see Figure 9). This will help protect the controller IC against latch-up due to the inductor voltage going negative. Although latch-up is unlikely, the use of such a catch diode will improve reliability and is highly recommended.

Non-Synchronous Operation - Schottky Diode

A typical Schottky diode, with a forward drop of 0.6V will dissipate $0.6 * 14 * [1 - 2.8/5] = 3.7W$ (compared to the 1.1 to 2.2W dissipated by a MOSFET under the same conditions). This power loss becomes much more significant at lower duty cycles – synchronous rectification is recommended especially when a 12V-power input is used. The use of a dual Schottky diode in a single TO-220 package (e.g. the MBR2535) helps improve thermal dissipation.

MOSFET GATE BIAS

The power MOSFETs can be biased by one of two methods: charge pump or 12V supply connected to V_{CI} .

1) Charge Pump (Bootstrap)

When 12V is supplied to the drain of the MOSFET, as in Figure 9, the gate drive needs to be higher than 12V in order to turn the MOSFET on. Capacitor C_{10} and diodes D_2 & D_3 are used as a charge pump voltage doubling circuit to raise the voltage of V_{CI} so that the TDRV pin always provides a high enough voltage to turn on Q_1 . The 12V supply must always be connected to V_{CC} to provide power for the IC itself, as well as gate drive for the bottom MOSFET.

2) 12V Supply

When 5V is supplied to the drain of Q_1 , a 12V supply should be connected to both V_{CC} and V_{CI} .

USING THE LX1664/65 DEVICES

LINEAR REGULATOR

Referring to the front page Product Highlight, a schematic is presented which uses a MOSFET as a series pass element for a linear regulator. The MOSFET is driven by the LX1664 controller, and down-converts a +5V or +3.3V supply to the desired V_{OUT} level, between 1.5 & 3.5V, as determined by the feedback resistors.

The current available from the Linear regulator is dictated by the supply capability, as well as the MOSFET ratings, and will typically lie in the 3-5 ampere range. This output is well suited for I/O buffers, memory, chipset and other components. Using 3.3V supply to convert to 1.5V for GTL+ Bus will significantly reduce heat dissipation in the MOSFET.

MOSFET Comments

Heatsinking the MOSFET becomes important, since the linear stage output current could approach 5 amperes in some applications. Since there are no switching losses, power dissipation in the MOSFET is simply defined by $P_D = (V_{IN} - V_{OUT}) * I$ output current. This means that a +5V_{IN} to +3.3V_{OUT} at 5A will require that the MOSFET dissipate $(5-3.3) * 5 = 8.5 \text{ watts}$. This amount of power in a MOSFET calls for a heatsink, which will be the same physical size as that required for a monolithic LDO, such as the LX8384 device.

The dropout voltage for the linear regulator stage is the product of $R_{DS(ON)} * I_{OUT}$. Using a 2SK1388 device at 5A, the dropout voltage will be (worst case) 37 milliohms x 5A = 185mV.

Note that the $R_{DS(ON)}$ of the (linear regulator) MOSFET does not affect heat dissipation, only dropout voltage. For reasons of economy, a FET with a higher resistance can be chosen for the linear regulator, e.g. 2SK1388 or IRLZ44.

TABLE 5 - Linear Regulator MOSFET Selection Guide

Device	$R_{DS(ON)}$ @ 10V (mΩ)	I_D @ $T_C = 100^\circ\text{C}$	Max. Break-down Voltage
IRFZ24N	70	12	55
IRL2703	40	17	30
IRLZ44N	22	29	55

Avoiding Crosstalk

To avoid a load transient on the switching output affecting the linear regulator, follow these guidelines:

- 1) Separate 5V supply traces to switching & linear FETs as much as possible.
- 2) Place capacitor C_9 as close to drain of Q_4 as possible.

Typical transient response is shown in Figure 13.

LINEAR REGULATOR (continued)

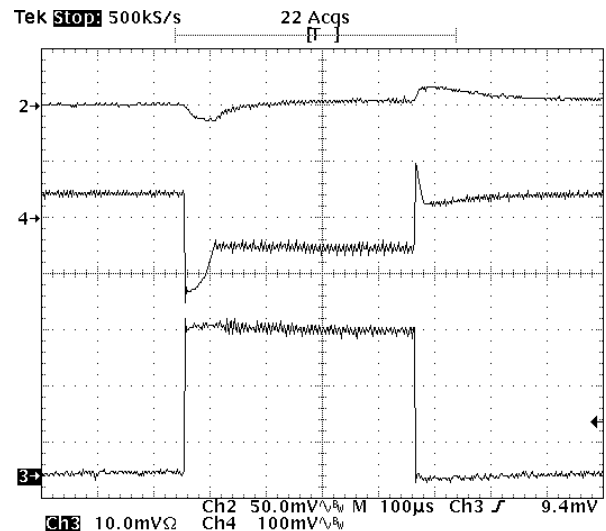

FIGURE 13 — Typical Transient Response

- Channel 2** = Linear Regulator Output.
Set point = 3.3V @ 2A (20mV/div.)
- Channel 4** = Switching Regulator Output.
 $V_{CC,CORE}$ set point = 2.8V
- Channel 3** = Switching Regulator Load Current
Transient 0 - 13A

Output Voltage Setting

As shown in Application Information Figures 6-9, two resistors (R_5 & R_6) set the linear regulator stage output voltage:

$$V_{OUT} = 1.5 * (R_5 + R_6) / R_6$$

As an example, to set resistor magnitudes, assume a desired V_{OUT} of 3.3 volts:

$$1.5 * (12.1k + 10k) / 10k = 3.3 \text{ volts (approximately)}$$

In general, the divider resistor values should be in the vicinity of 10-12k ohm for optimal noise performance. Please refer to Table 6.

LX1664/64A, LX1665/65A

DUAL OUTPUT PWM CONTROLLERS WITH 5-BIT DAC

PRODUCTION DATA SHEET

USING THE LX1664/65 DEVICES

LINEAR REGULATOR (continued)

**TABLE 6 -
Resistors Settings for Linear Regulator Output Voltage**

Nominal Set Point (V)	R ₅ (kΩ)	R ₆ (kΩ)	V _{OUT} (V)
3.3	12	10	3.30
3.2	11.3	10	3.20
3.1	11.3	10.7	3.08
3.0	11	11	3.00
2.9	10.3	11	2.90
2.8	10	11.5	2.80
2.7	10	12.4	2.71
2.6	10	13.7	2.59
2.5	9.76	14.7	2.50
2.4	8.87	14.7	2.41
2.3	8.87	16.5	2.31
2.2	8.87	18.7	2.21
2.1	8.87	22.1	2.10
2.0	8.87	26.7	2.00
1.9	8.87	21	2.13
1.8	7.15	35.7	1.80
1.7	7.15	53.6	1.70
1.6	7.15	100	1.61
1.5	7.15	∞	1.50

Capacitor Selection

Referring to the Product Highlight schematic on the front page, the standard value to use as the linear regulator stage output capacitor is on the order of 330μF. This provides sufficient hold-up for all expected transient load events in memory and I/O circuitry.

Disabling Linear Output

Linear regulator output can be disabled by pulling feedback pin (L_{FB}) up to 5V as shown in Figure 14.

TABLE 7 - Linear Enable (LIN EN) Function Table

LIN EN	LIN OUTPUT
H	Disabled
L	Enabled

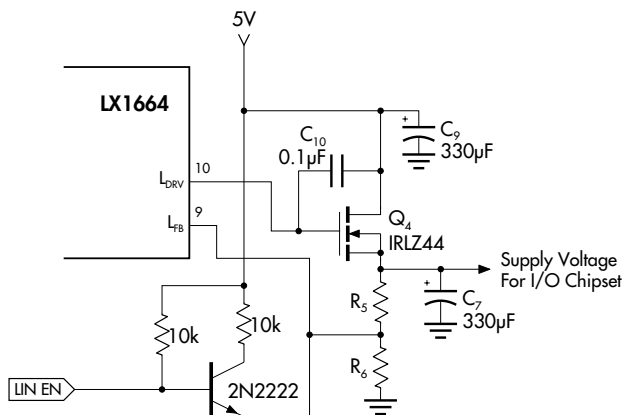

FIGURE 14 — Enabling Linear Regulator

LAYOUT GUIDELINES - THERMAL DESIGN

A great deal of time and effort were spent optimizing the thermal design of the demo boards. Any user who intends to implement an embedded motherboard would be well advised to carefully read and follow these guidelines. If the FET switches have been carefully selected, external heatsinking is generally not required. However, this means that copper trace on the PC board must now be used. This is a potential trouble spot; as much copper area as possible must be dedicated to heatsinking the FET switches, and the diode as well if a non-synchronous solution is used.

In our VRM module, heatsink area was taken from internal ground and V_{CC} planes which were actually split and connected with VIAS to the power device tabs. The TO-220 and TO-263 cases are well suited for this application, and are the preferred packages. Remember to remove any conformal coating from all exposed PC traces which are involved in heatsinking.

General Notes

As always, be sure to provide local capacitive decoupling close to the chip. Be sure use ground plane construction for all high-frequency work. Use low ESR capacitors where justified, but be alert for damping and ringing problems. High-frequency designs demand careful routing and layout, and may require several iterations to achieve desired performance levels.

Power Traces

To reduce power losses due to ohmic resistance, careful consideration should be given to the layout of traces that carry high currents. The main paths to consider are:

- Input power from 5V supply to drain of top MOSFET.
- Trace between top MOSFET and lower MOSFET or Schottky diode.
- Trace between lower MOSFET or Schottky diode and ground.
- Trace between source of top MOSFET and inductor, sense resistor and load.

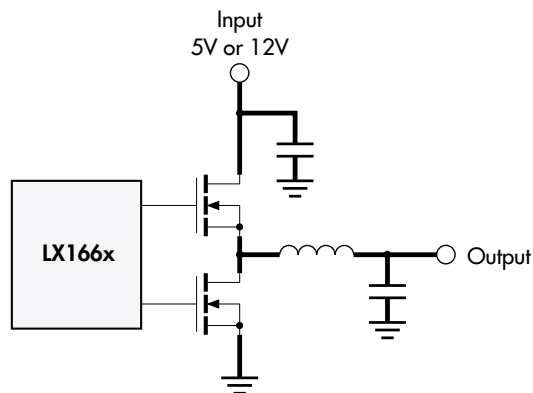

FIGURE 15 — Power Traces

LX1664/1664A, LX1665/65A

DUAL OUTPUT PWM CONTROLLERS WITH 5-BIT DAC

PRODUCTION DATA SHEET

USING THE LX1664/65 DEVICES

LAYOUT GUIDELINES - THERMAL DESIGN (continued)

All of these traces should be made as wide and thick as possible, in order to minimize resistance and hence power losses. It is also recommended that, whenever possible, the ground, input and output power signals should be on separate planes (PCB layers). See Figure 15 – bold traces are power traces.

C_s Input Decoupling (V_{CC}) Capacitor

Ensure that this 1 μ F capacitor is placed as close to the IC as possible to minimize the effects of noise on the device.

Layout Assistance

Please contact Linfinity's Applications Engineers for assistance with any layout or component selection issues. A Gerber file with layout for the most popular devices is available upon request.

Evaluation boards are also available upon request. Please check Linfinity's web site for further application notes.

RELATED DEVICES

LX1662/1663 - Single Output PWM Controllers
LX1553 - PWM Controller for 5V - 3.3V Conversion
LX1668 - Triple Output PWM Controller



Pentium is a registered trademark of Intel Corporation.

Cyrix is a registered trademark and 6x86 and Gx86 are trademarks of Cyrix Corporation. K6 is a trademark of AMD.
Power PC is a trademark of International Business Machines Corporation. Alpha is a trademark of Digital Equipment Corporation.

PRODUCTION DATA - Information contained in this document is proprietary to Linfinity, and is current as of publication date. This document may not be modified in any way without the express written consent of Linfinity. Product processing does not necessarily include testing of all parameters. Linfinity reserves the right to change the configuration and performance of the product and to discontinue product at any time.

Looking for pricing, stock, or lifecycle information?

Click below to explore more details on WIN SOURCE:

-  [View LX1664CD on WIN SOURCE](#)
-  [Microsemi Corporation](#) Information

Optimize Your Supply Chain with WIN SOURCE Solutions

-  Global Sourcing Solution
-  Obsolete Management
-  Cost Control Management
-  Shortage Management
-  Alternative Solution
-  Excess Inventory Management