



**THE DATASHEET OF
LX4F231H5QRFIGA3**





Stellaris[®] LM4F231H5QR Microcontroller

DATA SHEET

Copyright

Copyright © 2007-2012 Texas Instruments Incorporated All rights reserved. Stellaris and StellarisWare® are registered trademarks of Texas Instruments Incorporated. ARM and Thumb are registered trademarks and Cortex is a trademark of ARM Limited. Other names and brands may be claimed as the property of others.

ADVANCE INFORMATION concerns new products in the sampling or preproduction phase of development. Characteristic data and other specifications are subject to change without notice.

 Please be aware that an important notice concerning availability, standard warranty, and use in critical applications of Texas Instruments semiconductor products and disclaimers thereto appears at the end of this data sheet.

Texas Instruments Incorporated
108 Wild Basin, Suite 350
Austin, TX 78746

<http://www.ti.com/stellaris>

<http://www-k.ext.ti.com/sc/technical-support/product-information-centers.htm>



**TEXAS
INSTRUMENTS**



Cortex
Intelligent Processors by ARM®

Table of Contents

Revision History	38
About This Document	42
Audience	42
About This Manual	42
Related Documents	42
Documentation Conventions	43
1 Architectural Overview	45
1.1 Stellaris LM4F Series Overview	45
1.2 LM4F231H5QR Microcontroller Overview	48
1.3 LM4F231H5QR Microcontroller Features	51
1.3.1 ARM Cortex-M4F Processor Core	51
1.3.2 On-Chip Memory	53
1.3.3 Serial Communications Peripherals	55
1.3.4 System Integration	59
1.3.5 Advanced Motion Control	64
1.3.6 Analog	66
1.3.7 JTAG and ARM Serial Wire Debug	68
1.3.8 Packaging and Temperature	69
1.4 LM4F231H5QR Microcontroller Hardware Details	69
2 The Cortex-M4F Processor	70
2.1 Block Diagram	71
2.2 Overview	72
2.2.1 System-Level Interface	72
2.2.2 Integrated Configurable Debug	72
2.2.3 Trace Port Interface Unit (TPIU)	73
2.2.4 Cortex-M4F System Component Details	73
2.3 Programming Model	74
2.3.1 Processor Mode and Privilege Levels for Software Execution	74
2.3.2 Stacks	75
2.3.3 Register Map	75
2.3.4 Register Descriptions	77
2.3.5 Exceptions and Interrupts	93
2.3.6 Data Types	93
2.4 Memory Model	93
2.4.1 Memory Regions, Types and Attributes	96
2.4.2 Memory System Ordering of Memory Accesses	96
2.4.3 Behavior of Memory Accesses	96
2.4.4 Software Ordering of Memory Accesses	97
2.4.5 Bit-Banding	98
2.4.6 Data Storage	100
2.4.7 Synchronization Primitives	101
2.5 Exception Model	102
2.5.1 Exception States	103
2.5.2 Exception Types	103
2.5.3 Exception Handlers	107

2.5.4	Vector Table	107
2.5.5	Exception Priorities	108
2.5.6	Interrupt Priority Grouping	109
2.5.7	Exception Entry and Return	109
2.6	Fault Handling	112
2.6.1	Fault Types	113
2.6.2	Fault Escalation and Hard Faults	113
2.6.3	Fault Status Registers and Fault Address Registers	114
2.6.4	Lockup	114
2.7	Power Management	115
2.7.1	Entering Sleep Modes	115
2.7.2	Wake Up from Sleep Mode	115
2.7.3	The Wake-Up Interrupt Controller	116
2.8	Instruction Set Summary	116
3	Cortex-M4 Peripherals	123
3.1	Functional Description	123
3.1.1	System Timer (SysTick)	124
3.1.2	Nested Vectored Interrupt Controller (NVIC)	125
3.1.3	System Control Block (SCB)	126
3.1.4	Memory Protection Unit (MPU)	126
3.1.5	Floating-Point Unit (FPU)	131
3.2	Register Map	135
3.3	System Timer (SysTick) Register Descriptions	138
3.4	NVIC Register Descriptions	142
3.5	System Control Block (SCB) Register Descriptions	157
3.6	Memory Protection Unit (MPU) Register Descriptions	186
3.7	Floating-Point Unit (FPU) Register Descriptions	195
4	JTAG Interface	201
4.1	Block Diagram	202
4.2	Signal Description	202
4.3	Functional Description	203
4.3.1	JTAG Interface Pins	203
4.3.2	JTAG TAP Controller	205
4.3.3	Shift Registers	205
4.3.4	Operational Considerations	206
4.4	Initialization and Configuration	208
4.5	Register Descriptions	208
4.5.1	Instruction Register (IR)	209
4.5.2	Data Registers	211
5	System Control	213
5.1	Signal Description	213
5.2	Functional Description	213
5.2.1	Device Identification	213
5.2.2	Reset Control	214
5.2.3	Non-Maskable Interrupt	218
5.2.4	Power Control	219
5.2.5	Clock Control	220
5.2.6	System Control	227

5.3	Initialization and Configuration	229
5.4	Register Map	229
5.5	System Control Register Descriptions	235
5.6	System Control Legacy Register Descriptions	431
6	System Exception Module	493
6.1	Functional Description	493
6.2	Register Map	493
6.3	Register Descriptions	493
7	Internal Memory	501
7.1	Block Diagram	501
7.2	Functional Description	502
7.2.1	SRAM	502
7.2.2	ROM	503
7.2.3	Flash Memory	505
7.2.4	EEPROM	509
7.3	Register Map	514
7.4	Flash Memory Register Descriptions (Flash Control Offset)	516
7.5	EEPROM Register Descriptions (EEPROM Offset)	534
7.6	Memory Register Descriptions (System Control Offset)	550
8	Micro Direct Memory Access (μDMA)	559
8.1	Block Diagram	560
8.2	Functional Description	560
8.2.1	Channel Assignments	561
8.2.2	Priority	562
8.2.3	Arbitration Size	562
8.2.4	Request Types	562
8.2.5	Channel Configuration	563
8.2.6	Transfer Modes	565
8.2.7	Transfer Size and Increment	573
8.2.8	Peripheral Interface	573
8.2.9	Software Request	573
8.2.10	Interrupts and Errors	574
8.3	Initialization and Configuration	574
8.3.1	Module Initialization	574
8.3.2	Configuring a Memory-to-Memory Transfer	575
8.3.3	Configuring a Peripheral for Simple Transmit	576
8.3.4	Configuring a Peripheral for Ping-Pong Receive	578
8.3.5	Configuring Channel Assignments	580
8.4	Register Map	580
8.5	μDMA Channel Control Structure	582
8.6	μDMA Register Descriptions	589
9	General-Purpose Input/Outputs (GPIOs)	623
9.1	Signal Description	623
9.2	Functional Description	625
9.2.1	Data Control	627
9.2.2	Interrupt Control	628
9.2.3	Mode Control	629

9.2.4	Commit Control	630
9.2.5	Pad Control	630
9.2.6	Identification	630
9.3	Initialization and Configuration	630
9.4	Register Map	631
9.5	Register Descriptions	634
10	General-Purpose Timers	677
10.1	Block Diagram	678
10.2	Signal Description	679
10.3	Functional Description	680
10.3.1	GPTM Reset Conditions	681
10.3.2	Timer Modes	681
10.3.3	Wait-for-Trigger Mode	691
10.3.4	Synchronizing GP Timer Blocks	692
10.3.5	DMA Operation	693
10.3.6	Accessing Concatenated 16/32-Bit GPTM Register Values	693
10.3.7	Accessing Concatenated 32/64-Bit Wide GPTM Register Values	693
10.4	Initialization and Configuration	695
10.4.1	One-Shot/Periodic Timer Mode	695
10.4.2	Real-Time Clock (RTC) Mode	696
10.4.3	Input Edge-Count Mode	696
10.4.4	Input Edge Timing Mode	697
10.4.5	PWM Mode	697
10.5	Register Map	698
10.6	Register Descriptions	699
11	Watchdog Timers	747
11.1	Block Diagram	748
11.2	Functional Description	748
11.2.1	Register Access Timing	749
11.3	Initialization and Configuration	749
11.4	Register Map	749
11.5	Register Descriptions	750
12	Analog-to-Digital Converter (ADC)	772
12.1	Block Diagram	773
12.2	Signal Description	774
12.3	Functional Description	775
12.3.1	Sample Sequencers	775
12.3.2	Module Control	776
12.3.3	Hardware Sample Averaging Circuit	779
12.3.4	Analog-to-Digital Converter	779
12.3.5	Differential Sampling	782
12.3.6	Internal Temperature Sensor	784
12.3.7	Digital Comparator Unit	785
12.4	Initialization and Configuration	789
12.4.1	Module Initialization	789
12.4.2	Sample Sequencer Configuration	790
12.5	Register Map	790
12.6	Register Descriptions	792

13	Universal Asynchronous Receivers/Transmitters (UARTs)	855
13.1	Block Diagram	856
13.2	Signal Description	856
13.3	Functional Description	857
13.3.1	Transmit/Receive Logic	857
13.3.2	Baud-Rate Generation	858
13.3.3	Data Transmission	859
13.3.4	Serial IR (SIR)	859
13.3.5	ISO 7816 Support	860
13.3.6	Modem Handshake Support	860
13.3.7	LIN Support	861
13.3.8	9-Bit UART Mode	863
13.3.9	FIFO Operation	863
13.3.10	Interrupts	864
13.3.11	Loopback Operation	865
13.3.12	DMA Operation	865
13.4	Initialization and Configuration	865
13.5	Register Map	866
13.6	Register Descriptions	868
14	Synchronous Serial Interface (SSI)	918
14.1	Block Diagram	919
14.2	Signal Description	919
14.3	Functional Description	920
14.3.1	Bit Rate Generation	920
14.3.2	FIFO Operation	921
14.3.3	Interrupts	921
14.3.4	Frame Formats	922
14.3.5	DMA Operation	929
14.4	Initialization and Configuration	930
14.5	Register Map	931
14.6	Register Descriptions	932
15	Inter-Integrated Circuit (I²C) Interface	961
15.1	Block Diagram	962
15.2	Signal Description	962
15.3	Functional Description	963
15.3.1	I ² C Bus Functional Overview	963
15.3.2	Available Speed Modes	967
15.3.3	Interrupts	968
15.3.4	Loopback Operation	969
15.3.5	Command Sequence Flow Charts	970
15.4	Initialization and Configuration	978
15.5	Register Map	979
15.6	Register Descriptions (I ² C Master)	980
15.7	Register Descriptions (I ² C Slave)	995
15.8	Register Descriptions (I ² C Status and Control)	1005
16	Controller Area Network (CAN) Module	1008
16.1	Block Diagram	1009

16.2	Signal Description	1009
16.3	Functional Description	1010
16.3.1	Initialization	1011
16.3.2	Operation	1011
16.3.3	Transmitting Message Objects	1012
16.3.4	Configuring a Transmit Message Object	1013
16.3.5	Updating a Transmit Message Object	1014
16.3.6	Accepting Received Message Objects	1014
16.3.7	Receiving a Data Frame	1015
16.3.8	Receiving a Remote Frame	1015
16.3.9	Receive/Transmit Priority	1016
16.3.10	Configuring a Receive Message Object	1016
16.3.11	Handling of Received Message Objects	1017
16.3.12	Handling of Interrupts	1019
16.3.13	Test Mode	1020
16.3.14	Bit Timing Configuration Error Considerations	1022
16.3.15	Bit Time and Bit Rate	1022
16.3.16	Calculating the Bit Timing Parameters	1024
16.4	Register Map	1027
16.5	CAN Register Descriptions	1028
17	Universal Serial Bus (USB) Controller	1059
17.1	Block Diagram	1060
17.2	Signal Description	1060
17.3	Functional Description	1061
17.3.1	Operation as a Device	1061
17.3.2	Operation as a Host	1066
17.3.3	OTG Mode	1070
17.3.4	DMA Operation	1072
17.4	Initialization and Configuration	1073
17.4.1	Pin Configuration	1073
17.4.2	Endpoint Configuration	1074
17.5	Register Map	1074
17.6	Register Descriptions	1080
18	Analog Comparators	1174
18.1	Block Diagram	1175
18.2	Signal Description	1175
18.3	Functional Description	1176
18.3.1	Internal Reference Programming	1176
18.4	Initialization and Configuration	1179
18.5	Register Map	1179
18.6	Register Descriptions	1180
19	Pulse Width Modulator (PWM)	1189
19.1	Block Diagram	1190
19.2	Signal Description	1191
19.3	Functional Description	1193
19.3.1	PWM Timer	1193
19.3.2	PWM Comparators	1193
19.3.3	PWM Signal Generator	1194

19.3.4	Dead-Band Generator	1195
19.3.5	Interrupt/ADC-Trigger Selector	1196
19.3.6	Synchronization Methods	1196
19.3.7	Fault Conditions	1197
19.3.8	Output Control Block	1198
19.4	Initialization and Configuration	1198
19.5	Register Map	1199
19.6	Register Descriptions	1202
20	Quadrature Encoder Interface (QEI)	1268
20.1	Block Diagram	1268
20.2	Signal Description	1269
20.3	Functional Description	1270
20.4	Initialization and Configuration	1272
20.5	Register Map	1273
20.6	Register Descriptions	1273
21	Pin Diagram	1290
22	Signal Tables	1291
22.1	Connections for Unused Signals	1320
23	Operating Characteristics	1321
24	Electrical Characteristics	1322
24.1	Maximum Ratings	1322
24.2	Recommended Operating Conditions	1323
24.3	Load Conditions	1324
24.4	JTAG and Boundary Scan	1325
24.5	Power and Brown-Out	1326
24.6	Reset	1327
24.7	On-Chip Low Drop-Out (LDO) Regulator	1328
24.8	Clocks	1329
24.8.1	PLL Specifications	1329
24.8.2	PIOSC Specifications	1330
24.8.3	Internal 30-kHz Oscillator Specifications	1330
24.8.4	Main Oscillator Specifications	1330
24.8.5	System Clock Specification with ADC Operation	1333
24.8.6	System Clock Specification with USB Operation	1333
24.9	Sleep Modes	1333
24.10	Flash Memory and EEPROM	1334
24.11	Input/Output Characteristics	1334
24.12	Analog-to-Digital Converter (ADC)	1335
24.13	Synchronous Serial Interface (SSI)	1337
24.14	Inter-Integrated Circuit (I ² C) Interface	1339
24.15	Universal Serial Bus (USB) Controller	1340
24.16	Analog Comparator	1340
24.17	Current Consumption	1341
24.17.1	Preliminary Current Consumption	1341
A	Register Quick Reference	1344
B	Ordering and Contact Information	1397

B.1	Ordering Information	1397
B.2	Part Markings	1397
B.3	Kits	1397
B.4	Support Information	1398
C	Package Information	1399
C.1	64-Pin LQFP Package	1399
C.1.1	Package Dimensions	1399

List of Figures

Figure 1-1.	Stellaris LM4F Block Diagram	46
Figure 1-2.	Stellaris LM4F231H5QR Microcontroller High-Level Block Diagram	50
Figure 2-1.	CPU Block Diagram	72
Figure 2-2.	TPIU Block Diagram	73
Figure 2-3.	Cortex-M4F Register Set	76
Figure 2-4.	Bit-Band Mapping	100
Figure 2-5.	Data Storage	101
Figure 2-6.	Vector Table	108
Figure 2-7.	Exception Stack Frame	111
Figure 3-1.	SRD Use Example	129
Figure 3-2.	FPU Register Bank	132
Figure 4-1.	JTAG Module Block Diagram	202
Figure 4-2.	Test Access Port State Machine	205
Figure 4-3.	IDCODE Register Format	211
Figure 4-4.	BYPASS Register Format	211
Figure 4-5.	Boundary Scan Register Format	212
Figure 5-1.	Basic \overline{RST} Configuration	216
Figure 5-2.	External Circuitry to Extend Power-On Reset	216
Figure 5-3.	Reset Circuit Controlled by Switch	217
Figure 5-4.	Power Architecture	220
Figure 5-5.	Main Clock Tree	222
Figure 5-6.	Module Clock Selection	229
Figure 7-1.	Internal Memory Block Diagram	501
Figure 7-2.	EEPROM Block Diagram	502
Figure 8-1.	μ DMA Block Diagram	560
Figure 8-2.	Example of Ping-Pong μ DMA Transaction	566
Figure 8-3.	Memory Scatter-Gather, Setup and Configuration	568
Figure 8-4.	Memory Scatter-Gather, μ DMA Copy Sequence	569
Figure 8-5.	Peripheral Scatter-Gather, Setup and Configuration	571
Figure 8-6.	Peripheral Scatter-Gather, μ DMA Copy Sequence	572
Figure 9-1.	Digital I/O Pads	626
Figure 9-2.	Analog/Digital I/O Pads	627
Figure 9-3.	GPIO DATA Write Example	628
Figure 9-4.	GPIO DATA Read Example	628
Figure 10-1.	GPTM Module Block Diagram	678
Figure 10-2.	Reading the RTC Value	685
Figure 10-3.	Input Edge-Count Mode Example, Counting Down	687
Figure 10-4.	16-Bit Input Edge-Time Mode Example	688
Figure 10-5.	16-Bit PWM Mode Example	690
Figure 10-6.	CCP Output, GPTMTnMATCHR > GPTMTnILR	690
Figure 10-7.	CCP Output, GPTMTnMATCHR = GPTMTnILR	691
Figure 10-8.	CCP Output, GPTMTnILR > GPTMTnMATCHR	691
Figure 10-9.	Timer Daisy Chain	692
Figure 11-1.	WDT Module Block Diagram	748
Figure 12-1.	Implementation of Two ADC Blocks	773
Figure 12-2.	ADC Module Block Diagram	774

Figure 12-3.	ADC Sample Phases	777
Figure 12-4.	Doubling the ADC Sample Rate	778
Figure 12-5.	Skewed Sampling	778
Figure 12-6.	Sample Averaging Example	779
Figure 12-7.	ADC Input Equivalency Diagram	780
Figure 12-8.	ADC Voltage Reference	781
Figure 12-9.	ADC Conversion Result	782
Figure 12-10.	Differential Voltage Representation	784
Figure 12-11.	Internal Temperature Sensor Characteristic	785
Figure 12-12.	Low-Band Operation (CIC=0x0 and/or CTC=0x0)	787
Figure 12-13.	Mid-Band Operation (CIC=0x1 and/or CTC=0x1)	788
Figure 12-14.	High-Band Operation (CIC=0x3 and/or CTC=0x3)	789
Figure 13-1.	UART Module Block Diagram	856
Figure 13-2.	UART Character Frame	858
Figure 13-3.	IrDA Data Modulation	860
Figure 13-4.	LIN Message	862
Figure 13-5.	LIN Synchronization Field	863
Figure 14-1.	SSI Module Block Diagram	919
Figure 14-2.	TI Synchronous Serial Frame Format (Single Transfer)	923
Figure 14-3.	TI Synchronous Serial Frame Format (Continuous Transfer)	923
Figure 14-4.	Freescal e SPI Format (Single Transfer) with SPO=0 and SPH=0	924
Figure 14-5.	Freescal e SPI Format (Continuous Transfer) with SPO=0 and SPH=0	924
Figure 14-6.	Freescal e SPI Frame Format with SPO=0 and SPH=1	925
Figure 14-7.	Freescal e SPI Frame Format (Single Transfer) with SPO=1 and SPH=0	926
Figure 14-8.	Freescal e SPI Frame Format (Continuous Transfer) with SPO=1 and SPH=0	926
Figure 14-9.	Freescal e SPI Frame Format with SPO=1 and SPH=1	927
Figure 14-10.	MICROWIRE Frame Format (Single Frame)	928
Figure 14-11.	MICROWIRE Frame Format (Continuous Transfer)	929
Figure 14-12.	MICROWIRE Frame Format, SSIFss Input Setup and Hold Requirements	929
Figure 15-1.	I ² C Block Diagram	962
Figure 15-2.	I ² C Bus Configuration	963
Figure 15-3.	START and STOP Conditions	964
Figure 15-4.	Complete Data Transfer with a 7-Bit Address	964
Figure 15-5.	R/S Bit in First Byte	965
Figure 15-6.	Data Validity During Bit Transfer on the I ² C Bus	965
Figure 15-7.	High-Speed Data Format	967
Figure 15-8.	Master Single TRANSMIT	971
Figure 15-9.	Master Single RECEIVE	972
Figure 15-10.	Master TRANSMIT with Repeated START	973
Figure 15-11.	Master RECEIVE with Repeated START	974
Figure 15-12.	Master RECEIVE with Repeated START after TRANSMIT with Repeated START	975
Figure 15-13.	Master TRANSMIT with Repeated START after RECEIVE with Repeated START	976
Figure 15-14.	High Speed Mode Master Transmit	977
Figure 15-15.	Slave Command Sequence	978
Figure 16-1.	CAN Controller Block Diagram	1009
Figure 16-2.	CAN Data/Remote Frame	1010

Figure 16-3.	Message Objects in a FIFO Buffer	1019
Figure 16-4.	CAN Bit Time	1023
Figure 17-1.	USB Module Block Diagram	1060
Figure 18-1.	Analog Comparator Module Block Diagram	1175
Figure 18-2.	Structure of Comparator Unit	1176
Figure 18-3.	Comparator Internal Reference Structure	1177
Figure 19-1.	PWM Module Diagram	1191
Figure 19-2.	PWM Generator Block Diagram	1191
Figure 19-3.	PWM Count-Down Mode	1194
Figure 19-4.	PWM Count-Up/Down Mode	1194
Figure 19-5.	PWM Generation Example In Count-Up/Down Mode	1195
Figure 19-6.	PWM Dead-Band Generator	1195
Figure 20-1.	QEI Block Diagram	1269
Figure 20-2.	Quadrature Encoder and Velocity Predivider Operation	1271
Figure 21-1.	64-Pin LQFP Package Pin Diagram	1290
Figure 24-1.	ESD Protection on GPIOs	1323
Figure 24-2.	ESD Protection on Non-Power, Non-GPIO, and Non-XOSCn Pins	1323
Figure 24-3.	Load Conditions	1324
Figure 24-4.	JTAG Test Clock Input Timing	1325
Figure 24-5.	JTAG Test Access Port (TAP) Timing	1326
Figure 24-6.	Power-On and Brown-Out Reset and Voltage Parameters	1327
Figure 24-7.	Brown-Out Reset Timing	1327
Figure 24-8.	External Reset Timing ($\overline{\text{RST}}$)	1328
Figure 24-9.	Software Reset Timing	1328
Figure 24-10.	Watchdog Reset Timing	1328
Figure 24-11.	MOSC Failure Reset Timing	1328
Figure 24-12.	ADC Input Equivalency Diagram	1337
Figure 24-13.	SSI Timing for TI Frame Format (FRF=01), Single Transfer Timing Measurement	1338
Figure 24-14.	SSI Timing for MICROWIRE Frame Format (FRF=10), Single Transfer	1338
Figure 24-15.	SSI Timing for SPI Frame Format (FRF=00), with SPH=1	1339
Figure 24-16.	I ² C Timing	1340
Figure C-1.	Stellaris LM4F231H5QR 64-Pin LQFP Package	1399

List of Tables

Table 1.	Revision History	38
Table 2.	Documentation Conventions	43
Table 1-1.	Stellaris LM4F Device Series	46
Table 1-2.	Stellaris LM4F23x Series	47
Table 1-3.	Stellaris LM4F Family of Devices	47
Table 1-4.	Stellaris LM4F231H5QR Microcontroller Features	48
Table 2-1.	Summary of Processor Mode, Privilege Level, and Stack Use	75
Table 2-2.	Processor Register Map	76
Table 2-3.	PSR Register Combinations	82
Table 2-4.	Memory Map	93
Table 2-5.	Memory Access Behavior	96
Table 2-6.	SRAM Memory Bit-Banding Regions	98
Table 2-7.	Peripheral Memory Bit-Banding Regions	99
Table 2-8.	Exception Types	104
Table 2-9.	Interrupts	105
Table 2-10.	Exception Return Behavior	112
Table 2-11.	Faults	113
Table 2-12.	Fault Status and Fault Address Registers	114
Table 2-13.	Cortex-M4F Instruction Summary	116
Table 3-1.	Core Peripheral Register Regions	123
Table 3-2.	Memory Attributes Summary	127
Table 3-3.	TEX, S, C, and B Bit Field Encoding	129
Table 3-4.	Cache Policy for Memory Attribute Encoding	130
Table 3-5.	AP Bit Field Encoding	130
Table 3-6.	Memory Region Attributes for Stellaris Microcontrollers	131
Table 3-7.	QNaN and SNaN Handling	134
Table 3-8.	Peripherals Register Map	135
Table 3-9.	Interrupt Priority Levels	165
Table 3-10.	Example SIZE Field Values	193
Table 4-1.	JTAG_SWD_SWO Signals (64LQFP)	202
Table 4-2.	JTAG Port Pins State after Power-On Reset or $\overline{\text{RST}}$ assertion	203
Table 4-3.	JTAG Instruction Register Commands	209
Table 5-1.	System Control & Clocks Signals (64LQFP)	213
Table 5-2.	Reset Sources	214
Table 5-3.	Clock Source Options	221
Table 5-4.	Possible System Clock Frequencies Using the SYSDIV Field	223
Table 5-5.	Examples of Possible System Clock Frequencies Using the SYSDIV2 Field	223
Table 5-6.	Examples of Possible System Clock Frequencies with DIV400=1	224
Table 5-7.	System Control Register Map	230
Table 5-8.	RCC2 Fields that Override RCC Fields	256
Table 6-1.	System Exception Register Map	493
Table 7-1.	Flash Memory Protection Policy Combinations	506
Table 7-2.	User-Programmable Flash Memory Resident Registers	509
Table 7-3.	Flash Register Map	514
Table 8-1.	μ DMA Channel Assignments	561
Table 8-2.	Request Type Support	563

Table 8-3.	Control Structure Memory Map	564
Table 8-4.	Channel Control Structure	564
Table 8-5.	μDMA Read Example: 8-Bit Peripheral	573
Table 8-6.	μDMA Interrupt Assignments	574
Table 8-7.	Channel Control Structure Offsets for Channel 30	575
Table 8-8.	Channel Control Word Configuration for Memory Transfer Example	575
Table 8-9.	Channel Control Structure Offsets for Channel 7	576
Table 8-10.	Channel Control Word Configuration for Peripheral Transmit Example	577
Table 8-11.	Primary and Alternate Channel Control Structure Offsets for Channel 8	578
Table 8-12.	Channel Control Word Configuration for Peripheral Ping-Pong Receive Example	579
Table 8-13.	μDMA Register Map	581
Table 9-1.	GPIO Pins With Non-Zero Reset Values	624
Table 9-2.	GPIO Pins and Alternate Functions (64LQFP)	624
Table 9-3.	GPIO Pad Configuration Examples	630
Table 9-4.	GPIO Interrupt Configuration Example	631
Table 9-5.	GPIO Pins With Non-Zero Reset Values	632
Table 9-6.	GPIO Register Map	632
Table 9-7.	GPIO Pins With Non-Zero Reset Values	644
Table 9-8.	GPIO Pins With Non-Zero Reset Values	650
Table 9-9.	GPIO Pins With Non-Zero Reset Values	652
Table 9-10.	GPIO Pins With Non-Zero Reset Values	655
Table 9-11.	GPIO Pins With Non-Zero Reset Values	661
Table 10-1.	Available CCP Pins	678
Table 10-2.	General-Purpose Timers Signals (64LQFP)	679
Table 10-3.	General-Purpose Timer Capabilities	681
Table 10-4.	Counter Values When the Timer is Enabled in Periodic or One-Shot Modes	682
Table 10-5.	16-Bit Timer With Prescaler Configurations	683
Table 10-6.	32-Bit Timer (configured in 32/64-bit mode) With Prescaler Configurations	683
Table 10-7.	Counter Values When the Timer is Enabled in RTC Mode	684
Table 10-8.	Counter Values When the Timer is Enabled in Input Edge-Count Mode	686
Table 10-9.	Counter Values When the Timer is Enabled in Input Event-Count Mode	687
Table 10-10.	Counter Values When the Timer is Enabled in PWM Mode	689
Table 10-11.	Timeout Actions for GPTM Modes	692
Table 10-12.	Timers Register Map	698
Table 11-1.	Watchdog Timers Register Map	750
Table 12-1.	ADC Signals (64LQFP)	774
Table 12-2.	Samples and FIFO Depth of Sequencers	775
Table 12-3.	Differential Sampling Pairs	782
Table 12-4.	ADC Register Map	790
Table 13-1.	UART Signals (64LQFP)	857
Table 13-2.	Flow Control Mode	861
Table 13-3.	UART Register Map	867
Table 14-1.	SSI Signals (64LQFP)	920
Table 14-2.	SSI Register Map	931
Table 15-1.	I ² C Signals (64LQFP)	962
Table 15-2.	Examples of I ² C Master Timer Period versus Speed Mode	968
Table 15-3.	Examples of I ² C Master Timer Period in High-Speed Mode	968

Table 15-4.	Inter-Integrated Circuit (I ² C) Interface Register Map	980
Table 15-5.	Write Field Decoding for I2CMCS[3:0] Field	985
Table 16-1.	Controller Area Network Signals (64LQFP)	1010
Table 16-2.	Message Object Configurations	1015
Table 16-3.	CAN Protocol Ranges	1023
Table 16-4.	CANBIT Register Values	1023
Table 16-5.	CAN Register Map	1027
Table 17-1.	USB Signals (64LQFP)	1060
Table 17-2.	Remainder (MAXLOAD/4)	1072
Table 17-3.	Actual Bytes Read	1072
Table 17-4.	Packet Sizes That Clear RXRDY	1073
Table 17-5.	Universal Serial Bus (USB) Controller Register Map	1074
Table 18-1.	Analog Comparators Signals (64LQFP)	1175
Table 18-2.	Internal Reference Voltage and ACREFACTL Field Values	1177
Table 18-3.	Analog Comparator Voltage Reference Characteristics, V _{DDA} = 3.3V, EN= 1, and RNG = 0	1178
Table 18-4.	Analog Comparator Voltage Reference Characteristics, V _{DDA} = 3.3V, EN= 1, and RNG = 1	1178
Table 18-5.	Analog Comparators Register Map	1179
Table 19-1.	PWM Signals (64LQFP)	1192
Table 19-2.	PWM Register Map	1199
Table 20-1.	QEI Signals (64LQFP)	1269
Table 20-2.	QEI Register Map	1273
Table 22-1.	GPIO Pins With Default Alternate Functions	1291
Table 22-2.	Signals by Pin Number	1292
Table 22-3.	Signals by Signal Name	1300
Table 22-4.	Signals by Function, Except for GPIO	1307
Table 22-5.	GPIO Pins and Alternate Functions	1314
Table 22-6.	Possible Pin Assignments for Alternate Functions	1316
Table 22-7.	Connections for Unused Signals (64-Pin LQFP)	1320
Table 23-1.	Temperature Characteristics	1321
Table 23-2.	Thermal Characteristics	1321
Table 23-3.	ESD Absolute Maximum Ratings	1321
Table 24-1.	Maximum Ratings	1322
Table 24-2.	Recommended DC Operating Conditions	1323
Table 24-3.	GPIO Current Restrictions	1324
Table 24-4.	GPIO Package Side Assignments	1324
Table 24-5.	JTAG Characteristics	1325
Table 24-6.	Power Characteristics	1326
Table 24-7.	Reset Characteristics	1327
Table 24-8.	LDO Regulator Characteristics	1328
Table 24-9.	Phase Locked Loop (PLL) Characteristics	1329
Table 24-10.	Actual PLL Frequency	1329
Table 24-11.	PIOSC Clock Characteristics	1330
Table 24-12.	30-kHz Clock Characteristics	1330
Table 24-13.	Main Oscillator Input Characteristics	1330
Table 24-14.	Crystal Parameters	1331
Table 24-15.	Supported MOSC Crystal Frequencies	1332

Table 24-16.	System Clock Characteristics with ADC Operation	1333
Table 24-17.	System Clock Characteristics with USB Operation	1333
Table 24-18.	Sleep Modes AC Characteristics	1333
Table 24-19.	Flash Memory Characteristics	1334
Table 24-20.	EEPROM Characteristics	1334
Table 24-21.	GPIO Module Characteristics	1335
Table 24-22.	ADC Electrical Characteristics	1335
Table 24-23.	SSI Characteristics	1337
Table 24-24.	I ² C Characteristics	1339
Table 24-25.	Analog Comparator Characteristics	1340
Table 24-26.	Analog Comparator Voltage Reference Characteristics	1340
Table 24-27.	Analog Comparator Voltage Reference Characteristics, V _{DDA} = 3.3V, EN= 1, and RNG = 0	1340
Table 24-28.	Analog Comparator Voltage Reference Characteristics, V _{DDA} = 3.3V, EN= 1, and RNG = 1	1341
Table 24-29.	Preliminary Current Consumption	1342
Table B-1.	Part Ordering Information	1397

List of Registers

The Cortex-M4F Processor	70
Register 1: Cortex General-Purpose Register 0 (R0)	78
Register 2: Cortex General-Purpose Register 1 (R1)	78
Register 3: Cortex General-Purpose Register 2 (R2)	78
Register 4: Cortex General-Purpose Register 3 (R3)	78
Register 5: Cortex General-Purpose Register 4 (R4)	78
Register 6: Cortex General-Purpose Register 5 (R5)	78
Register 7: Cortex General-Purpose Register 6 (R6)	78
Register 8: Cortex General-Purpose Register 7 (R7)	78
Register 9: Cortex General-Purpose Register 8 (R8)	78
Register 10: Cortex General-Purpose Register 9 (R9)	78
Register 11: Cortex General-Purpose Register 10 (R10)	78
Register 12: Cortex General-Purpose Register 11 (R11)	78
Register 13: Cortex General-Purpose Register 12 (R12)	78
Register 14: Stack Pointer (SP)	79
Register 15: Link Register (LR)	80
Register 16: Program Counter (PC)	81
Register 17: Program Status Register (PSR)	82
Register 18: Priority Mask Register (PRIMASK)	86
Register 19: Fault Mask Register (FAULTMASK)	87
Register 20: Base Priority Mask Register (BASEPRI)	88
Register 21: Control Register (CONTROL)	89
Register 22: Floating-Point Status Control (FPSC)	91
Cortex-M4 Peripherals	123
Register 1: SysTick Control and Status Register (STCTRL), offset 0x010	139
Register 2: SysTick Reload Value Register (STRELOAD), offset 0x014	141
Register 3: SysTick Current Value Register (STCURRENT), offset 0x018	142
Register 4: Interrupt 0-31 Set Enable (EN0), offset 0x100	143
Register 5: Interrupt 32-63 Set Enable (EN1), offset 0x104	143
Register 6: Interrupt 64-95 Set Enable (EN2), offset 0x108	143
Register 7: Interrupt 96-127 Set Enable (EN3), offset 0x10C	143
Register 8: Interrupt 128-138 Set Enable (EN4), offset 0x110	144
Register 9: Interrupt 0-31 Clear Enable (DIS0), offset 0x180	145
Register 10: Interrupt 32-63 Clear Enable (DIS1), offset 0x184	145
Register 11: Interrupt 64-95 Clear Enable (DIS2), offset 0x188	145
Register 12: Interrupt 96-127 Clear Enable (DIS3), offset 0x18C	145
Register 13: Interrupt 128-138 Clear Enable (DIS4), offset 0x190	146
Register 14: Interrupt 0-31 Set Pending (PEND0), offset 0x200	147
Register 15: Interrupt 32-63 Set Pending (PEND1), offset 0x204	147
Register 16: Interrupt 64-95 Set Pending (PEND2), offset 0x208	147
Register 17: Interrupt 96-127 Set Pending (PEND3), offset 0x20C	147
Register 18: Interrupt 128-138 Set Pending (PEND4), offset 0x210	148
Register 19: Interrupt 0-31 Clear Pending (UNPEND0), offset 0x280	149
Register 20: Interrupt 32-63 Clear Pending (UNPEND1), offset 0x284	149
Register 21: Interrupt 64-95 Clear Pending (UNPEND2), offset 0x288	149

Register 22:	Interrupt 96-127 Clear Pending (UNPEND3), offset 0x28C	149
Register 23:	Interrupt 128-138 Clear Pending (UNPEND4), offset 0x290	150
Register 24:	Interrupt 0-31 Active Bit (ACTIVE0), offset 0x300	151
Register 25:	Interrupt 32-63 Active Bit (ACTIVE1), offset 0x304	151
Register 26:	Interrupt 64-95 Active Bit (ACTIVE2), offset 0x308	151
Register 27:	Interrupt 96-127 Active Bit (ACTIVE3), offset 0x30C	151
Register 28:	Interrupt 128-138 Active Bit (ACTIVE4), offset 0x310	152
Register 29:	Interrupt 0-3 Priority (PRI0), offset 0x400	153
Register 30:	Interrupt 4-7 Priority (PRI1), offset 0x404	153
Register 31:	Interrupt 8-11 Priority (PRI2), offset 0x408	153
Register 32:	Interrupt 12-15 Priority (PRI3), offset 0x40C	153
Register 33:	Interrupt 16-19 Priority (PRI4), offset 0x410	153
Register 34:	Interrupt 20-23 Priority (PRI5), offset 0x414	153
Register 35:	Interrupt 24-27 Priority (PRI6), offset 0x418	153
Register 36:	Interrupt 28-31 Priority (PRI7), offset 0x41C	153
Register 37:	Interrupt 32-35 Priority (PRI8), offset 0x420	153
Register 38:	Interrupt 36-39 Priority (PRI9), offset 0x424	153
Register 39:	Interrupt 40-43 Priority (PRI10), offset 0x428	153
Register 40:	Interrupt 44-47 Priority (PRI11), offset 0x42C	153
Register 41:	Interrupt 48-51 Priority (PRI12), offset 0x430	153
Register 42:	Interrupt 52-55 Priority (PRI13), offset 0x434	153
Register 43:	Interrupt 56-59 Priority (PRI14), offset 0x438	153
Register 44:	Interrupt 60-63 Priority (PRI15), offset 0x43C	153
Register 45:	Interrupt 64-67 Priority (PRI16), offset 0x440	155
Register 46:	Interrupt 68-71 Priority (PRI17), offset 0x444	155
Register 47:	Interrupt 72-75 Priority (PRI18), offset 0x448	155
Register 48:	Interrupt 76-79 Priority (PRI19), offset 0x44C	155
Register 49:	Interrupt 80-83 Priority (PRI20), offset 0x450	155
Register 50:	Interrupt 84-87 Priority (PRI21), offset 0x454	155
Register 51:	Interrupt 88-91 Priority (PRI22), offset 0x458	155
Register 52:	Interrupt 92-95 Priority (PRI23), offset 0x45C	155
Register 53:	Interrupt 96-99 Priority (PRI24), offset 0x460	155
Register 54:	Interrupt 100-103 Priority (PRI25), offset 0x464	155
Register 55:	Interrupt 104-107 Priority (PRI26), offset 0x468	155
Register 56:	Interrupt 108-111 Priority (PRI27), offset 0x46C	155
Register 57:	Interrupt 112-115 Priority (PRI28), offset 0x470	155
Register 58:	Interrupt 116-119 Priority (PRI29), offset 0x474	155
Register 59:	Interrupt 120-123 Priority (PRI30), offset 0x478	155
Register 60:	Interrupt 124-127 Priority (PRI31), offset 0x47C	155
Register 61:	Interrupt 128-131 Priority (PRI32), offset 0x480	155
Register 62:	Interrupt 132-135 Priority (PRI33), offset 0x484	155
Register 63:	Interrupt 136-138 Priority (PRI34), offset 0x488	155
Register 64:	Software Trigger Interrupt (SWTRIG), offset 0xF00	157
Register 65:	Auxiliary Control (ACTLR), offset 0x008	158
Register 66:	CPU ID Base (CPUID), offset 0xD00	160
Register 67:	Interrupt Control and State (INTCTRL), offset 0xD04	161
Register 68:	Vector Table Offset (VTABLE), offset 0xD08	164
Register 69:	Application Interrupt and Reset Control (APINT), offset 0xD0C	165

Register 70:	System Control (SYSCTRL), offset 0xD10	167
Register 71:	Configuration and Control (CFGCTRL), offset 0xD14	169
Register 72:	System Handler Priority 1 (SYSPRI1), offset 0xD18	171
Register 73:	System Handler Priority 2 (SYSPRI2), offset 0xD1C	172
Register 74:	System Handler Priority 3 (SYSPRI3), offset 0xD20	173
Register 75:	System Handler Control and State (SYSHNDCTRL), offset 0xD24	174
Register 76:	Configurable Fault Status (FAULTSTAT), offset 0xD28	178
Register 77:	Hard Fault Status (HFAULTSTAT), offset 0xD2C	184
Register 78:	Memory Management Fault Address (MMADDR), offset 0xD34	185
Register 79:	Bus Fault Address (FAULTADDR), offset 0xD38	186
Register 80:	MPU Type (MPUTYPE), offset 0xD90	187
Register 81:	MPU Control (MPUCTRL), offset 0xD94	188
Register 82:	MPU Region Number (MPUNUMBER), offset 0xD98	190
Register 83:	MPU Region Base Address (MPUBASE), offset 0xD9C	191
Register 84:	MPU Region Base Address Alias 1 (MPUBASE1), offset 0xDA4	191
Register 85:	MPU Region Base Address Alias 2 (MPUBASE2), offset 0xDAC	191
Register 86:	MPU Region Base Address Alias 3 (MPUBASE3), offset 0xDB4	191
Register 87:	MPU Region Attribute and Size (MPUATTR), offset 0xDA0	193
Register 88:	MPU Region Attribute and Size Alias 1 (MPUATTR1), offset 0xDA8	193
Register 89:	MPU Region Attribute and Size Alias 2 (MPUATTR2), offset 0xDB0	193
Register 90:	MPU Region Attribute and Size Alias 3 (MPUATTR3), offset 0xDB8	193
Register 91:	Coprocessor Access Control (CPAC), offset 0xD88	196
Register 92:	Floating-Point Context Control (FPCC), offset 0xF34	197
Register 93:	Floating-Point Context Address (FPCA), offset 0xF38	199
Register 94:	Floating-Point Default Status Control (FPDSC), offset 0xF3C	200
System Control		213
Register 1:	Device Identification 0 (DID0), offset 0x000	236
Register 2:	Device Identification 1 (DID1), offset 0x004	238
Register 3:	Brown-Out Reset Control (PBORCTL), offset 0x030	240
Register 4:	Raw Interrupt Status (RIS), offset 0x050	241
Register 5:	Interrupt Mask Control (IMC), offset 0x054	243
Register 6:	Masked Interrupt Status and Clear (MISC), offset 0x058	245
Register 7:	Reset Cause (RESC), offset 0x05C	247
Register 8:	Run-Mode Clock Configuration (RCC), offset 0x060	249
Register 9:	GPIO High-Performance Bus Control (GPIOHBCTL), offset 0x06C	254
Register 10:	Run-Mode Clock Configuration 2 (RCC2), offset 0x070	256
Register 11:	Main Oscillator Control (MOSCCTL), offset 0x07C	259
Register 12:	Deep Sleep Clock Configuration (DSLPCCLKCFG), offset 0x144	260
Register 13:	System Properties (SYSPROP), offset 0x14C	262
Register 14:	Precision Internal Oscillator Calibration (PIOSCCAL), offset 0x150	263
Register 15:	PLL Frequency 0 (PLLFREQ0), offset 0x160	264
Register 16:	PLL Frequency 1 (PLLFREQ1), offset 0x164	265
Register 17:	PLL Status (PLLSTAT), offset 0x168	266
Register 18:	Watchdog Timer Peripheral Present (PPWD), offset 0x300	267
Register 19:	16/32-Bit General-Purpose Timer Peripheral Present (PPTIMER), offset 0x304	268
Register 20:	General-Purpose Input/Output Peripheral Present (PPGPIO), offset 0x308	270
Register 21:	Micro Direct Memory Access Peripheral Present (PPDMA), offset 0x30C	273
Register 22:	Hibernation Peripheral Present (PPHIB), offset 0x314	274

Register 23:	Universal Asynchronous Receiver/Transmitter Peripheral Present (PPUART), offset 0x318	275
Register 24:	Synchronous Serial Interface Peripheral Present (PPSSI), offset 0x31C	277
Register 25:	Inter-Integrated Circuit Peripheral Present (PPI2C), offset 0x320	279
Register 26:	Universal Serial Bus Peripheral Present (PPUSB), offset 0x328	281
Register 27:	Controller Area Network Peripheral Present (PPCAN), offset 0x334	282
Register 28:	Analog-to-Digital Converter Peripheral Present (PPADC), offset 0x338	283
Register 29:	Analog Comparator Peripheral Present (PPACMP), offset 0x33C	284
Register 30:	Pulse Width Modulator Peripheral Present (PPPWM), offset 0x340	285
Register 31:	Quadrature Encoder Interface Peripheral Present (PPQEI), offset 0x344	286
Register 32:	EEPROM Peripheral Present (PPEEPROM), offset 0x358	287
Register 33:	32/64-Bit Wide General-Purpose Timer Peripheral Present (PPWTIMER), offset 0x35C	288
Register 34:	Watchdog Timer Software Reset (SRWD), offset 0x500	290
Register 35:	16/32-Bit General-Purpose Timer Software Reset (SRTIMER), offset 0x504	292
Register 36:	General-Purpose Input/Output Software Reset (SRGPIO), offset 0x508	294
Register 37:	Micro Direct Memory Access Software Reset (SRDMA), offset 0x50C	296
Register 38:	Universal Asynchronous Receiver/Transmitter Software Reset (SRUART), offset 0x518	297
Register 39:	Synchronous Serial Interface Software Reset (SRSSI), offset 0x51C	299
Register 40:	Inter-Integrated Circuit Software Reset (SRI2C), offset 0x520	301
Register 41:	Universal Serial Bus Software Reset (SRUSB), offset 0x528	303
Register 42:	Controller Area Network Software Reset (SRCAN), offset 0x534	304
Register 43:	Analog-to-Digital Converter Software Reset (SRADC), offset 0x538	306
Register 44:	Analog Comparator Software Reset (SRACMP), offset 0x53C	308
Register 45:	Pulse Width Modulator Software Reset (SRPWM), offset 0x540	309
Register 46:	Quadrature Encoder Interface Software Reset (SRQEI), offset 0x544	311
Register 47:	EEPROM Software Reset (SREEEPROM), offset 0x558	313
Register 48:	32/64-Bit Wide General-Purpose Timer Software Reset (SRWTIMER), offset 0x55C	314
Register 49:	Watchdog Timer Run Mode Clock Gating Control (RCGCWD), offset 0x600	316
Register 50:	16/32-Bit General-Purpose Timer Run Mode Clock Gating Control (RCGCTIMER), offset 0x604	317
Register 51:	General-Purpose Input/Output Run Mode Clock Gating Control (RCGCGPIO), offset 0x608	319
Register 52:	Micro Direct Memory Access Run Mode Clock Gating Control (RCGCDMA), offset 0x60C	321
Register 53:	Universal Asynchronous Receiver/Transmitter Run Mode Clock Gating Control (RCGCUART), offset 0x618	322
Register 54:	Synchronous Serial Interface Run Mode Clock Gating Control (RCGCSSI), offset 0x61C	324
Register 55:	Inter-Integrated Circuit Run Mode Clock Gating Control (RCGCI2C), offset 0x620	326
Register 56:	Universal Serial Bus Run Mode Clock Gating Control (RCGCUSB), offset 0x628	328
Register 57:	Controller Area Network Run Mode Clock Gating Control (RCGCCAN), offset 0x634	329
Register 58:	Analog-to-Digital Converter Run Mode Clock Gating Control (RCGCADC), offset 0x638	330
Register 59:	Analog Comparator Run Mode Clock Gating Control (RCGCACMP), offset 0x63C	331
Register 60:	Pulse Width Modulator Run Mode Clock Gating Control (RCGCPWM), offset 0x640	332
Register 61:	Quadrature Encoder Interface Run Mode Clock Gating Control (RCGCQEI), offset 0x644	333
Register 62:	EEPROM Run Mode Clock Gating Control (RCGCEEPROM), offset 0x658	334
Register 63:	32/64-Bit Wide General-Purpose Timer Run Mode Clock Gating Control (RCGCWTIMER), offset 0x65C	335

Register 64:	Watchdog Timer Sleep Mode Clock Gating Control (SCGCWD), offset 0x700	337
Register 65:	16/32-Bit General-Purpose Timer Sleep Mode Clock Gating Control (SCGCTIMER), offset 0x704	338
Register 66:	General-Purpose Input/Output Sleep Mode Clock Gating Control (SCGCGPIO), offset 0x708	340
Register 67:	Micro Direct Memory Access Sleep Mode Clock Gating Control (SCGCDMA), offset 0x70C	342
Register 68:	Universal Asynchronous Receiver/Transmitter Sleep Mode Clock Gating Control (SCGCUART), offset 0x718	343
Register 69:	Synchronous Serial Interface Sleep Mode Clock Gating Control (SCGCSSI), offset 0x71C	345
Register 70:	Inter-Integrated Circuit Sleep Mode Clock Gating Control (SCGCI2C), offset 0x720	347
Register 71:	Universal Serial Bus Sleep Mode Clock Gating Control (SCGCUSB), offset 0x728	349
Register 72:	Controller Area Network Sleep Mode Clock Gating Control (SCGCCAN), offset 0x734	350
Register 73:	Analog-to-Digital Converter Sleep Mode Clock Gating Control (SCGCADC), offset 0x738	351
Register 74:	Analog Comparator Sleep Mode Clock Gating Control (SCGCACMP), offset 0x73C	352
Register 75:	Pulse Width Modulator Sleep Mode Clock Gating Control (SCGCPWM), offset 0x740	353
Register 76:	Quadrature Encoder Interface Sleep Mode Clock Gating Control (SCGCQEI), offset 0x744	354
Register 77:	EEPROM Sleep Mode Clock Gating Control (SCGCEEPROM), offset 0x758	355
Register 78:	32/64-Bit Wide General-Purpose Timer Sleep Mode Clock Gating Control (SCGCWTIMER), offset 0x75C	356
Register 79:	Watchdog Timer Deep-Sleep Mode Clock Gating Control (DCGCWD), offset 0x800	358
Register 80:	16/32-Bit General-Purpose Timer Deep-Sleep Mode Clock Gating Control (DCGCTIMER), offset 0x804	359
Register 81:	General-Purpose Input/Output Deep-Sleep Mode Clock Gating Control (DCGCGPIO), offset 0x808	361
Register 82:	Micro Direct Memory Access Deep-Sleep Mode Clock Gating Control (DCGCDMA), offset 0x80C	363
Register 83:	Universal Asynchronous Receiver/Transmitter Deep-Sleep Mode Clock Gating Control (DCGCUART), offset 0x818	364
Register 84:	Synchronous Serial Interface Deep-Sleep Mode Clock Gating Control (DCGCSSI), offset 0x81C	366
Register 85:	Inter-Integrated Circuit Deep-Sleep Mode Clock Gating Control (DCGCI2C), offset 0x820	368
Register 86:	Universal Serial Bus Deep-Sleep Mode Clock Gating Control (DCGCUSB), offset 0x828	370
Register 87:	Controller Area Network Deep-Sleep Mode Clock Gating Control (DCGCCAN), offset 0x834	371
Register 88:	Analog-to-Digital Converter Deep-Sleep Mode Clock Gating Control (DCGCADC), offset 0x838	372
Register 89:	Analog Comparator Deep-Sleep Mode Clock Gating Control (DCGCACMP), offset 0x83C	373
Register 90:	Pulse Width Modulator Deep-Sleep Mode Clock Gating Control (DCGCPWM), offset 0x840	374
Register 91:	Quadrature Encoder Interface Deep-Sleep Mode Clock Gating Control (DCGCQEI), offset 0x844	375
Register 92:	EEPROM Deep-Sleep Mode Clock Gating Control (DCGCEEPROM), offset 0x858	376

Register 93:	32/64-Bit Wide General-Purpose Timer Deep-Sleep Mode Clock Gating Control (DCGCWTIMER), offset 0x85C	377
Register 94:	Watchdog Timer Power Control (PCWD), offset 0x900	379
Register 95:	16/32-Bit General-Purpose Timer Power Control (PCTIMER), offset 0x904	381
Register 96:	General-Purpose Input/Output Power Control (PCGPIO), offset 0x908	384
Register 97:	Micro Direct Memory Access Power Control (PCDMA), offset 0x90C	387
Register 98:	Universal Asynchronous Receiver/Transmitter Power Control (PCUART), offset 0x918	388
Register 99:	Synchronous Serial Interface Power Control (PCSSI), offset 0x91C	392
Register 100:	Inter-Integrated Circuit Power Control (PCI2C), offset 0x920	394
Register 101:	Universal Serial Bus Power Control (PCUSB), offset 0x928	397
Register 102:	Controller Area Network Power Control (PCCAN), offset 0x934	398
Register 103:	Analog-to-Digital Converter Power Control (PCADC), offset 0x938	400
Register 104:	Analog Comparator Power Control (PCACMP), offset 0x93C	402
Register 105:	Pulse Width Modulator Power Control (PCPWM), offset 0x940	403
Register 106:	Quadrature Encoder Interface Power Control (PCQEI), offset 0x944	405
Register 107:	EEPROM Power Control (PCEEPROM), offset 0x958	407
Register 108:	32/64-Bit Wide General-Purpose Timer Power Control (PCWTIMER), offset 0x95C	408
Register 109:	Watchdog Timer Peripheral Ready (PRWD), offset 0xA00	411
Register 110:	16/32-Bit General-Purpose Timer Peripheral Ready (PRTIMER), offset 0xA04	412
Register 111:	General-Purpose Input/Output Peripheral Ready (PRGPIO), offset 0xA08	414
Register 112:	Micro Direct Memory Access Peripheral Ready (PRDMA), offset 0xA0C	416
Register 113:	Universal Asynchronous Receiver/Transmitter Peripheral Ready (PRUART), offset 0xA18	417
Register 114:	Synchronous Serial Interface Peripheral Ready (PRSSI), offset 0xA1C	419
Register 115:	Inter-Integrated Circuit Peripheral Ready (PRI2C), offset 0xA20	421
Register 116:	Universal Serial Bus Peripheral Ready (PRUSB), offset 0xA28	423
Register 117:	Controller Area Network Peripheral Ready (PRCAN), offset 0xA34	424
Register 118:	Analog-to-Digital Converter Peripheral Ready (PRADC), offset 0xA38	425
Register 119:	Analog Comparator Peripheral Ready (PRACMP), offset 0xA3C	426
Register 120:	Pulse Width Modulator Peripheral Ready (PRPWM), offset 0xA40	427
Register 121:	Quadrature Encoder Interface Peripheral Ready (PRQEI), offset 0xA44	428
Register 122:	EEPROM Peripheral Ready (PREEPROM), offset 0xA58	429
Register 123:	32/64-Bit Wide General-Purpose Timer Peripheral Ready (PRWTIMER), offset 0xA5C	430
Register 124:	Device Capabilities 0 (DC0), offset 0x008	432
Register 125:	Device Capabilities 1 (DC1), offset 0x010	434
Register 126:	Device Capabilities 2 (DC2), offset 0x014	437
Register 127:	Device Capabilities 3 (DC3), offset 0x018	440
Register 128:	Device Capabilities 4 (DC4), offset 0x01C	444
Register 129:	Device Capabilities 5 (DC5), offset 0x020	447
Register 130:	Device Capabilities 6 (DC6), offset 0x024	449
Register 131:	Device Capabilities 7 (DC7), offset 0x028	450
Register 132:	Device Capabilities 8 (DC8), offset 0x02C	453
Register 133:	Software Reset Control 0 (SRCR0), offset 0x040	456
Register 134:	Software Reset Control 1 (SRCR1), offset 0x044	458
Register 135:	Software Reset Control 2 (SRCR2), offset 0x048	461
Register 136:	Run Mode Clock Gating Control Register 0 (RCGC0), offset 0x100	463
Register 137:	Run Mode Clock Gating Control Register 1 (RCGC1), offset 0x104	467
Register 138:	Run Mode Clock Gating Control Register 2 (RCGC2), offset 0x108	471

Register 139: Sleep Mode Clock Gating Control Register 0 (SCGC0), offset 0x110	474
Register 140: Sleep Mode Clock Gating Control Register 1 (SCGC1), offset 0x114	477
Register 141: Sleep Mode Clock Gating Control Register 2 (SCGC2), offset 0x118	480
Register 142: Deep Sleep Mode Clock Gating Control Register 0 (DCGC0), offset 0x120	482
Register 143: Deep-Sleep Mode Clock Gating Control Register 1 (DCGC1), offset 0x124	485
Register 144: Deep Sleep Mode Clock Gating Control Register 2 (DCGC2), offset 0x128	488
Register 145: Device Capabilities 9 (DC9), offset 0x190	490
Register 146: Non-Volatile Memory Information (NVMSTAT), offset 0x1A0	492
System Exception Module	493
Register 1: System Exception Raw Interrupt Status (SYSEXCRI), offset 0x000	494
Register 2: System Exception Interrupt Mask (SYSEXCIM), offset 0x004	496
Register 3: System Exception Masked Interrupt Status (SYSEXCMI), offset 0x008	498
Register 4: System Exception Interrupt Clear (SYSEXCIC), offset 0x00C	500
Internal Memory	501
Register 1: Flash Memory Address (FMA), offset 0x000	517
Register 2: Flash Memory Data (FMD), offset 0x004	518
Register 3: Flash Memory Control (FMC), offset 0x008	519
Register 4: Flash Controller Raw Interrupt Status (FCRIS), offset 0x00C	521
Register 5: Flash Controller Interrupt Mask (FCIM), offset 0x010	524
Register 6: Flash Controller Masked Interrupt Status and Clear (FCMISC), offset 0x014	526
Register 7: Flash Memory Control 2 (FMC2), offset 0x020	529
Register 8: Flash Write Buffer Valid (FWBVAL), offset 0x030	530
Register 9: Flash Write Buffer n (FWBn), offset 0x100 - 0x17C	531
Register 10: Flash Size (FSIZE), offset 0xFC0	532
Register 11: SRAM Size (SSIZE), offset 0xFC4	533
Register 12: ROM Software Map (ROMSWMAP), offset 0xFCC	534
Register 13: EEPROM Size Information (EESIZE), offset 0x000	535
Register 14: EEPROM Current Block (EEBLOCK), offset 0x004	536
Register 15: EEPROM Current Offset (EEOFFSET), offset 0x008	537
Register 16: EEPROM Read-Write (EERDWR), offset 0x010	538
Register 17: EEPROM Read-Write with Increment (EERDWRINC), offset 0x014	539
Register 18: EEPROM Done Status (EEDONE), offset 0x018	540
Register 19: EEPROM Support Control and Status (EESUPP), offset 0x01C	542
Register 20: EEPROM Unlock (EEUNLOCK), offset 0x020	544
Register 21: EEPROM Protection (EEPROT), offset 0x030	545
Register 22: EEPROM Password (EEPASS0), offset 0x034	546
Register 23: EEPROM Password (EEPASS1), offset 0x038	546
Register 24: EEPROM Password (EEPASS2), offset 0x03C	546
Register 25: EEPROM Interrupt (EEINT), offset 0x040	547
Register 26: EEPROM Block Hide (EEHIDE), offset 0x050	548
Register 27: EEPROM Debug Mass Erase (EEDBGME), offset 0x080	549
Register 28: EEPROM Peripheral Properties (EEPROMPP), offset 0xFC0	550
Register 29: ROM Control (RMCTL), offset 0x0F0	551
Register 30: Flash Memory Protection Read Enable 0 (FMPRE0), offset 0x130 and 0x200	552
Register 31: Flash Memory Protection Read Enable 1 (FMPRE1), offset 0x204	552
Register 32: Flash Memory Protection Read Enable 2 (FMPRE2), offset 0x208	552
Register 33: Flash Memory Protection Read Enable 3 (FMPRE3), offset 0x20C	552
Register 34: Flash Memory Protection Program Enable 0 (FMPPE0), offset 0x134 and 0x400	553

Register 35:	Flash Memory Protection Program Enable 1 (FMPPE1), offset 0x404	553
Register 36:	Flash Memory Protection Program Enable 2 (FMPPE2), offset 0x408	553
Register 37:	Flash Memory Protection Program Enable 3 (FMPPE3), offset 0x40C	553
Register 38:	Boot Configuration (BOOTCFG), offset 0x1D0	555
Register 39:	User Register 0 (USER_REG0), offset 0x1E0	558
Register 40:	User Register 1 (USER_REG1), offset 0x1E4	558
Register 41:	User Register 2 (USER_REG2), offset 0x1E8	558
Register 42:	User Register 3 (USER_REG3), offset 0x1EC	558
Micro Direct Memory Access (μDMA)		559
Register 1:	DMA Channel Source Address End Pointer (DMASRCENDP), offset 0x000	583
Register 2:	DMA Channel Destination Address End Pointer (DMADSTENDP), offset 0x004	584
Register 3:	DMA Channel Control Word (DMACHCTL), offset 0x008	585
Register 4:	DMA Status (DMASTAT), offset 0x000	590
Register 5:	DMA Configuration (DMACFG), offset 0x004	592
Register 6:	DMA Channel Control Base Pointer (DMACTLBASE), offset 0x008	593
Register 7:	DMA Alternate Channel Control Base Pointer (DMAALTBASE), offset 0x00C	594
Register 8:	DMA Channel Wait-on-Request Status (DMAWAITSTAT), offset 0x010	595
Register 9:	DMA Channel Software Request (DMASWREQ), offset 0x014	596
Register 10:	DMA Channel Useburst Set (DMAUSEBURSTSET), offset 0x018	597
Register 11:	DMA Channel Useburst Clear (DMAUSEBURSTCLR), offset 0x01C	598
Register 12:	DMA Channel Request Mask Set (DMAREQMASKSET), offset 0x020	599
Register 13:	DMA Channel Request Mask Clear (DMAREQMASKCLR), offset 0x024	600
Register 14:	DMA Channel Enable Set (DMAENASET), offset 0x028	601
Register 15:	DMA Channel Enable Clear (DMAENACL), offset 0x02C	602
Register 16:	DMA Channel Primary Alternate Set (DMAALTSET), offset 0x030	603
Register 17:	DMA Channel Primary Alternate Clear (DMAALTCLR), offset 0x034	604
Register 18:	DMA Channel Priority Set (DMAPRIOSET), offset 0x038	605
Register 19:	DMA Channel Priority Clear (DMAPRIOCLR), offset 0x03C	606
Register 20:	DMA Bus Error Clear (DMAERRCLR), offset 0x04C	607
Register 21:	DMA Channel Assignment (DMACHASGN), offset 0x500	608
Register 22:	DMA Channel Interrupt Status (DMACHIS), offset 0x504	609
Register 23:	DMA Channel Map Select 0 (DMACHMAP0), offset 0x510	610
Register 24:	DMA Channel Map Select 1 (DMACHMAP1), offset 0x514	611
Register 25:	DMA Channel Map Select 2 (DMACHMAP2), offset 0x518	612
Register 26:	DMA Channel Map Select 3 (DMACHMAP3), offset 0x51C	613
Register 27:	DMA Peripheral Identification 0 (DMAPeriphID0), offset 0xFE0	614
Register 28:	DMA Peripheral Identification 1 (DMAPeriphID1), offset 0xFE4	615
Register 29:	DMA Peripheral Identification 2 (DMAPeriphID2), offset 0xFE8	616
Register 30:	DMA Peripheral Identification 3 (DMAPeriphID3), offset 0xFEC	617
Register 31:	DMA Peripheral Identification 4 (DMAPeriphID4), offset 0xFD0	618
Register 32:	DMA PrimeCell Identification 0 (DMAPCellID0), offset 0xFF0	619
Register 33:	DMA PrimeCell Identification 1 (DMAPCellID1), offset 0xFF4	620
Register 34:	DMA PrimeCell Identification 2 (DMAPCellID2), offset 0xFF8	621
Register 35:	DMA PrimeCell Identification 3 (DMAPCellID3), offset 0xFFC	622
General-Purpose Input/Outputs (GPIOs)		623
Register 1:	GPIO Data (GPIODATA), offset 0x000	635
Register 2:	GPIO Direction (GPIODIR), offset 0x400	636
Register 3:	GPIO Interrupt Sense (GPIOIS), offset 0x404	637

Register 4:	GPIO Interrupt Both Edges (GPIOIBE), offset 0x408	638
Register 5:	GPIO Interrupt Event (GPIOIEV), offset 0x40C	639
Register 6:	GPIO Interrupt Mask (GPIOIM), offset 0x410	640
Register 7:	GPIO Raw Interrupt Status (GPIORIS), offset 0x414	641
Register 8:	GPIO Masked Interrupt Status (GPIOMIS), offset 0x418	642
Register 9:	GPIO Interrupt Clear (GPIOICR), offset 0x41C	643
Register 10:	GPIO Alternate Function Select (GPIOAFSEL), offset 0x420	644
Register 11:	GPIO 2-mA Drive Select (GPIODR2R), offset 0x500	646
Register 12:	GPIO 4-mA Drive Select (GPIODR4R), offset 0x504	647
Register 13:	GPIO 8-mA Drive Select (GPIODR8R), offset 0x508	648
Register 14:	GPIO Open Drain Select (GPIOODR), offset 0x50C	649
Register 15:	GPIO Pull-Up Select (GPIOPUR), offset 0x510	650
Register 16:	GPIO Pull-Down Select (GPIOPDR), offset 0x514	652
Register 17:	GPIO Slew Rate Control Select (GPIOSLR), offset 0x518	654
Register 18:	GPIO Digital Enable (GPIODEN), offset 0x51C	655
Register 19:	GPIO Lock (GPIOLOCK), offset 0x520	657
Register 20:	GPIO Commit (GPIOCR), offset 0x524	658
Register 21:	GPIO Analog Mode Select (GPIOAMSEL), offset 0x528	660
Register 22:	GPIO Port Control (GPIOPCTL), offset 0x52C	661
Register 23:	GPIO ADC Control (GPIOADCCTL), offset 0x530	663
Register 24:	GPIO DMA Control (GPIODMACTL), offset 0x534	664
Register 25:	GPIO Peripheral Identification 4 (GPIOPeriphID4), offset 0xFD0	665
Register 26:	GPIO Peripheral Identification 5 (GPIOPeriphID5), offset 0xFD4	666
Register 27:	GPIO Peripheral Identification 6 (GPIOPeriphID6), offset 0xFD8	667
Register 28:	GPIO Peripheral Identification 7 (GPIOPeriphID7), offset 0xFDC	668
Register 29:	GPIO Peripheral Identification 0 (GPIOPeriphID0), offset 0xFE0	669
Register 30:	GPIO Peripheral Identification 1 (GPIOPeriphID1), offset 0xFE4	670
Register 31:	GPIO Peripheral Identification 2 (GPIOPeriphID2), offset 0xFE8	671
Register 32:	GPIO Peripheral Identification 3 (GPIOPeriphID3), offset 0xFEC	672
Register 33:	GPIO PrimeCell Identification 0 (GPIOPCellID0), offset 0xFF0	673
Register 34:	GPIO PrimeCell Identification 1 (GPIOPCellID1), offset 0xFF4	674
Register 35:	GPIO PrimeCell Identification 2 (GPIOPCellID2), offset 0xFF8	675
Register 36:	GPIO PrimeCell Identification 3 (GPIOPCellID3), offset 0xFFC	676
General-Purpose Timers		677
Register 1:	GPTM Configuration (GPTMCFG), offset 0x000	700
Register 2:	GPTM Timer A Mode (GPTMTAMR), offset 0x004	702
Register 3:	GPTM Timer B Mode (GPTMTBMR), offset 0x008	706
Register 4:	GPTM Control (GPTMCTL), offset 0x00C	710
Register 5:	GPTM Synchronize (GPTMSYNC), offset 0x010	714
Register 6:	GPTM Interrupt Mask (GPTMIMR), offset 0x018	718
Register 7:	GPTM Raw Interrupt Status (GPTMRIS), offset 0x01C	721
Register 8:	GPTM Masked Interrupt Status (GPTMMIS), offset 0x020	724
Register 9:	GPTM Interrupt Clear (GPTMICR), offset 0x024	727
Register 10:	GPTM Timer A Interval Load (GPTMTAILR), offset 0x028	729
Register 11:	GPTM Timer B Interval Load (GPTMTBILR), offset 0x02C	730
Register 12:	GPTM Timer A Match (GPTMTAMATCHR), offset 0x030	731
Register 13:	GPTM Timer B Match (GPTMTBMATCHR), offset 0x034	732
Register 14:	GPTM Timer A Prescale (GPTMTAPR), offset 0x038	733

Register 15:	GPTM Timer B Prescale (GPTMTBPR), offset 0x03C	734
Register 16:	GPTM TimerA Prescale Match (GPTMTAPMR), offset 0x040	735
Register 17:	GPTM TimerB Prescale Match (GPTMTBPMR), offset 0x044	736
Register 18:	GPTM Timer A (GPTMTAR), offset 0x048	737
Register 19:	GPTM Timer B (GPTMTBR), offset 0x04C	738
Register 20:	GPTM Timer A Value (GPTMTAV), offset 0x050	739
Register 21:	GPTM Timer B Value (GPTMTBV), offset 0x054	740
Register 22:	GPTM RTC Predivide (GPTMRTCPD), offset 0x058	741
Register 23:	GPTM Timer A Prescale Snapshot (GPTMTAPS), offset 0x05C	742
Register 24:	GPTM Timer B Prescale Snapshot (GPTMTBPS), offset 0x060	743
Register 25:	GPTM Timer A Prescale Value (GPTMTAPV), offset 0x064	744
Register 26:	GPTM Timer B Prescale Value (GPTMTBPV), offset 0x068	745
Register 27:	GPTM Peripheral Properties (GPTMPP), offset 0xFC0	746
Watchdog Timers		747
Register 1:	Watchdog Load (WDTLOAD), offset 0x000	751
Register 2:	Watchdog Value (WDTVALUE), offset 0x004	752
Register 3:	Watchdog Control (WDTCTL), offset 0x008	753
Register 4:	Watchdog Interrupt Clear (WDTICR), offset 0x00C	755
Register 5:	Watchdog Raw Interrupt Status (WDTRIS), offset 0x010	756
Register 6:	Watchdog Masked Interrupt Status (WDTMIS), offset 0x014	757
Register 7:	Watchdog Test (WDTTEST), offset 0x418	758
Register 8:	Watchdog Lock (WDTLOCK), offset 0xC00	759
Register 9:	Watchdog Peripheral Identification 4 (WDTPeriphID4), offset 0xFD0	760
Register 10:	Watchdog Peripheral Identification 5 (WDTPeriphID5), offset 0xFD4	761
Register 11:	Watchdog Peripheral Identification 6 (WDTPeriphID6), offset 0xFD8	762
Register 12:	Watchdog Peripheral Identification 7 (WDTPeriphID7), offset 0xFDC	763
Register 13:	Watchdog Peripheral Identification 0 (WDTPeriphID0), offset 0xFE0	764
Register 14:	Watchdog Peripheral Identification 1 (WDTPeriphID1), offset 0xFE4	765
Register 15:	Watchdog Peripheral Identification 2 (WDTPeriphID2), offset 0xFE8	766
Register 16:	Watchdog Peripheral Identification 3 (WDTPeriphID3), offset 0xFEC	767
Register 17:	Watchdog PrimeCell Identification 0 (WDTPCellID0), offset 0xFF0	768
Register 18:	Watchdog PrimeCell Identification 1 (WDTPCellID1), offset 0xFF4	769
Register 19:	Watchdog PrimeCell Identification 2 (WDTPCellID2), offset 0xFF8	770
Register 20:	Watchdog PrimeCell Identification 3 (WDTPCellID3), offset 0xFFC	771
Analog-to-Digital Converter (ADC)		772
Register 1:	ADC Active Sample Sequencer (ADCACTSS), offset 0x000	793
Register 2:	ADC Raw Interrupt Status (ADCRIS), offset 0x004	794
Register 3:	ADC Interrupt Mask (ADCIM), offset 0x008	796
Register 4:	ADC Interrupt Status and Clear (ADCISC), offset 0x00C	798
Register 5:	ADC Overflow Status (ADCOSTAT), offset 0x010	801
Register 6:	ADC Event Multiplexer Select (ADCEMUX), offset 0x014	803
Register 7:	ADC Underflow Status (ADCUSTAT), offset 0x018	808
Register 8:	ADC Trigger Source Select (ADCTSSEL), offset 0x01C	809
Register 9:	ADC Sample Sequencer Priority (ADCSSPRI), offset 0x020	811
Register 10:	ADC Sample Phase Control (ADCSPC), offset 0x024	813
Register 11:	ADC Processor Sample Sequence Initiate (ADCPSSI), offset 0x028	815
Register 12:	ADC Sample Averaging Control (ADCSAC), offset 0x030	817
Register 13:	ADC Digital Comparator Interrupt Status and Clear (ADCDCISC), offset 0x034	818

Register 14:	ADC Sample Sequence Input Multiplexer Select 0 (ADCSSMUX0), offset 0x040	820
Register 15:	ADC Sample Sequence Control 0 (ADCSSCTL0), offset 0x044	822
Register 16:	ADC Sample Sequence Result FIFO 0 (ADCSSFIFO0), offset 0x048	825
Register 17:	ADC Sample Sequence Result FIFO 1 (ADCSSFIFO1), offset 0x068	825
Register 18:	ADC Sample Sequence Result FIFO 2 (ADCSSFIFO2), offset 0x088	825
Register 19:	ADC Sample Sequence Result FIFO 3 (ADCSSFIFO3), offset 0x0A8	825
Register 20:	ADC Sample Sequence FIFO 0 Status (ADCSSFSTAT0), offset 0x04C	826
Register 21:	ADC Sample Sequence FIFO 1 Status (ADCSSFSTAT1), offset 0x06C	826
Register 22:	ADC Sample Sequence FIFO 2 Status (ADCSSFSTAT2), offset 0x08C	826
Register 23:	ADC Sample Sequence FIFO 3 Status (ADCSSFSTAT3), offset 0x0AC	826
Register 24:	ADC Sample Sequence 0 Operation (ADCSSOP0), offset 0x050	828
Register 25:	ADC Sample Sequence 0 Digital Comparator Select (ADCSSDC0), offset 0x054	830
Register 26:	ADC Sample Sequence Input Multiplexer Select 1 (ADCSSMUX1), offset 0x060	832
Register 27:	ADC Sample Sequence Input Multiplexer Select 2 (ADCSSMUX2), offset 0x080	832
Register 28:	ADC Sample Sequence Control 1 (ADCSSCTL1), offset 0x064	833
Register 29:	ADC Sample Sequence Control 2 (ADCSSCTL2), offset 0x084	833
Register 30:	ADC Sample Sequence 1 Operation (ADCSSOP1), offset 0x070	835
Register 31:	ADC Sample Sequence 2 Operation (ADCSSOP2), offset 0x090	835
Register 32:	ADC Sample Sequence 1 Digital Comparator Select (ADCSSDC1), offset 0x074	836
Register 33:	ADC Sample Sequence 2 Digital Comparator Select (ADCSSDC2), offset 0x094	836
Register 34:	ADC Sample Sequence Input Multiplexer Select 3 (ADCSSMUX3), offset 0x0A0	838
Register 35:	ADC Sample Sequence Control 3 (ADCSSCTL3), offset 0x0A4	839
Register 36:	ADC Sample Sequence 3 Operation (ADCSSOP3), offset 0x0B0	840
Register 37:	ADC Sample Sequence 3 Digital Comparator Select (ADCSSDC3), offset 0x0B4	841
Register 38:	ADC Digital Comparator Reset Initial Conditions (ADCDCRIC), offset 0xD00	842
Register 39:	ADC Digital Comparator Control 0 (ADCDCCTL0), offset 0xE00	847
Register 40:	ADC Digital Comparator Control 1 (ADCDCCTL1), offset 0xE04	847
Register 41:	ADC Digital Comparator Control 2 (ADCDCCTL2), offset 0xE08	847
Register 42:	ADC Digital Comparator Control 3 (ADCDCCTL3), offset 0xE0C	847
Register 43:	ADC Digital Comparator Control 4 (ADCDCCTL4), offset 0xE10	847
Register 44:	ADC Digital Comparator Control 5 (ADCDCCTL5), offset 0xE14	847
Register 45:	ADC Digital Comparator Control 6 (ADCDCCTL6), offset 0xE18	847
Register 46:	ADC Digital Comparator Control 7 (ADCDCCTL7), offset 0xE1C	847
Register 47:	ADC Digital Comparator Range 0 (ADCDCCMP0), offset 0xE40	850
Register 48:	ADC Digital Comparator Range 1 (ADCDCCMP1), offset 0xE44	850
Register 49:	ADC Digital Comparator Range 2 (ADCDCCMP2), offset 0xE48	850
Register 50:	ADC Digital Comparator Range 3 (ADCDCCMP3), offset 0xE4C	850
Register 51:	ADC Digital Comparator Range 4 (ADCDCCMP4), offset 0xE50	850
Register 52:	ADC Digital Comparator Range 5 (ADCDCCMP5), offset 0xE54	850
Register 53:	ADC Digital Comparator Range 6 (ADCDCCMP6), offset 0xE58	850
Register 54:	ADC Digital Comparator Range 7 (ADCDCCMP7), offset 0xE5C	850
Register 55:	ADC Peripheral Properties (ADCPP), offset 0xFC0	851
Register 56:	ADC Peripheral Configuration (ADCPC), offset 0xFC4	853
Register 57:	ADC Clock Configuration (ADCCC), offset 0xFC8	854
Universal Asynchronous Receivers/Transmitters (UARTs)		855
Register 1:	UART Data (UARTDR), offset 0x000	869
Register 2:	UART Receive Status/Error Clear (UARTRSR/UARTECR), offset 0x004	871
Register 3:	UART Flag (UARTFR), offset 0x018	874

Register 4:	UART IrDA Low-Power Register (UARTILPR), offset 0x020	876
Register 5:	UART Integer Baud-Rate Divisor (UARTIBRD), offset 0x024	877
Register 6:	UART Fractional Baud-Rate Divisor (UARTFBRD), offset 0x028	878
Register 7:	UART Line Control (UARTLCRH), offset 0x02C	879
Register 8:	UART Control (UARTCTL), offset 0x030	881
Register 9:	UART Interrupt FIFO Level Select (UARTIFLS), offset 0x034	885
Register 10:	UART Interrupt Mask (UARTIM), offset 0x038	887
Register 11:	UART Raw Interrupt Status (UARTRIS), offset 0x03C	890
Register 12:	UART Masked Interrupt Status (UARTMIS), offset 0x040	893
Register 13:	UART Interrupt Clear (UARTICR), offset 0x044	896
Register 14:	UART DMA Control (UARTDMACTL), offset 0x048	898
Register 15:	UART LIN Control (UARTLCTL), offset 0x090	899
Register 16:	UART LIN Snap Shot (UARTLSS), offset 0x094	900
Register 17:	UART LIN Timer (UARTLTIM), offset 0x098	901
Register 18:	UART 9-Bit Self Address (UART9BITADDR), offset 0x0A4	902
Register 19:	UART 9-Bit Self Address Mask (UART9BITAMASK), offset 0x0A8	903
Register 20:	UART Peripheral Properties (UARTPPP), offset 0xFC0	904
Register 21:	UART Clock Configuration (UARTCC), offset 0xFC8	905
Register 22:	UART Peripheral Identification 4 (UARTPeriphID4), offset 0xFD0	906
Register 23:	UART Peripheral Identification 5 (UARTPeriphID5), offset 0xFD4	907
Register 24:	UART Peripheral Identification 6 (UARTPeriphID6), offset 0xFD8	908
Register 25:	UART Peripheral Identification 7 (UARTPeriphID7), offset 0xFDC	909
Register 26:	UART Peripheral Identification 0 (UARTPeriphID0), offset 0xFE0	910
Register 27:	UART Peripheral Identification 1 (UARTPeriphID1), offset 0xFE4	911
Register 28:	UART Peripheral Identification 2 (UARTPeriphID2), offset 0xFE8	912
Register 29:	UART Peripheral Identification 3 (UARTPeriphID3), offset 0xFEC	913
Register 30:	UART PrimeCell Identification 0 (UARTPCellID0), offset 0xFF0	914
Register 31:	UART PrimeCell Identification 1 (UARTPCellID1), offset 0xFF4	915
Register 32:	UART PrimeCell Identification 2 (UARTPCellID2), offset 0xFF8	916
Register 33:	UART PrimeCell Identification 3 (UARTPCellID3), offset 0xFFC	917
Synchronous Serial Interface (SSI)		918
Register 1:	SSI Control 0 (SSICR0), offset 0x000	933
Register 2:	SSI Control 1 (SSICR1), offset 0x004	935
Register 3:	SSI Data (SSIDR), offset 0x008	937
Register 4:	SSI Status (SSISR), offset 0x00C	938
Register 5:	SSI Clock Prescale (SSICPSR), offset 0x010	940
Register 6:	SSI Interrupt Mask (SSIIM), offset 0x014	941
Register 7:	SSI Raw Interrupt Status (SSIRIS), offset 0x018	942
Register 8:	SSI Masked Interrupt Status (SSIMIS), offset 0x01C	944
Register 9:	SSI Interrupt Clear (SSIICR), offset 0x020	946
Register 10:	SSI DMA Control (SSIDMACTL), offset 0x024	947
Register 11:	SSI Clock Configuration (SSICC), offset 0xFC8	948
Register 12:	SSI Peripheral Identification 4 (SSIPeriphID4), offset 0xFD0	949
Register 13:	SSI Peripheral Identification 5 (SSIPeriphID5), offset 0xFD4	950
Register 14:	SSI Peripheral Identification 6 (SSIPeriphID6), offset 0xFD8	951
Register 15:	SSI Peripheral Identification 7 (SSIPeriphID7), offset 0xFDC	952
Register 16:	SSI Peripheral Identification 0 (SSIPeriphID0), offset 0xFE0	953
Register 17:	SSI Peripheral Identification 1 (SSIPeriphID1), offset 0xFE4	954

Register 18:	SSI Peripheral Identification 2 (SSIPeriphID2), offset 0xFE8	955
Register 19:	SSI Peripheral Identification 3 (SSIPeriphID3), offset 0xFEC	956
Register 20:	SSI PrimeCell Identification 0 (SSIPCellID0), offset 0xFF0	957
Register 21:	SSI PrimeCell Identification 1 (SSIPCellID1), offset 0xFF4	958
Register 22:	SSI PrimeCell Identification 2 (SSIPCellID2), offset 0xFF8	959
Register 23:	SSI PrimeCell Identification 3 (SSIPCellID3), offset 0xFFC	960
Inter-Integrated Circuit (I²C) Interface		961
Register 1:	I ² C Master Slave Address (I2CMSA), offset 0x000	981
Register 2:	I ² C Master Control/Status (I2CMCS), offset 0x004	982
Register 3:	I ² C Master Data (I2CMDR), offset 0x008	987
Register 4:	I ² C Master Timer Period (I2CMTPR), offset 0x00C	988
Register 5:	I ² C Master Interrupt Mask (I2CMIMR), offset 0x010	989
Register 6:	I ² C Master Raw Interrupt Status (I2CMRIS), offset 0x014	990
Register 7:	I ² C Master Masked Interrupt Status (I2CMMIS), offset 0x018	991
Register 8:	I ² C Master Interrupt Clear (I2CMICR), offset 0x01C	992
Register 9:	I ² C Master Configuration (I2CMCR), offset 0x020	993
Register 10:	I ² C Master Clock Low Timeout Count (I2CMCLKOCNT), offset 0x024	994
Register 11:	I ² C Master Bus Monitor (I2CMBMON), offset 0x02C	995
Register 12:	I ² C Slave Own Address (I2CSOAR), offset 0x800	996
Register 13:	I ² C Slave Control/Status (I2CSCSR), offset 0x804	997
Register 14:	I ² C Slave Data (I2CSDR), offset 0x808	999
Register 15:	I ² C Slave Interrupt Mask (I2CSIMR), offset 0x80C	1000
Register 16:	I ² C Slave Raw Interrupt Status (I2CSRIS), offset 0x810	1001
Register 17:	I ² C Slave Masked Interrupt Status (I2CSMIS), offset 0x814	1002
Register 18:	I ² C Slave Interrupt Clear (I2CSICR), offset 0x818	1003
Register 19:	I ² C Slave Own Address 2 (I2CSOAR2), offset 0x81C	1004
Register 20:	I ² C Slave ACK Control (I2CSACKCTL), offset 0x820	1005
Register 21:	I ² C Peripheral Properties (I2CPP), offset 0xFC0	1006
Register 22:	I ² C Peripheral Configuration (I2CPC), offset 0xFC4	1007
Controller Area Network (CAN) Module		1008
Register 1:	CAN Control (CANCTL), offset 0x000	1030
Register 2:	CAN Status (CANSTS), offset 0x004	1032
Register 3:	CAN Error Counter (CANERR), offset 0x008	1035
Register 4:	CAN Bit Timing (CANBIT), offset 0x00C	1036
Register 5:	CAN Interrupt (CANINT), offset 0x010	1037
Register 6:	CAN Test (CANTST), offset 0x014	1038
Register 7:	CAN Baud Rate Prescaler Extension (CANBRPE), offset 0x018	1040
Register 8:	CAN IF1 Command Request (CANIF1CRQ), offset 0x020	1041
Register 9:	CAN IF2 Command Request (CANIF2CRQ), offset 0x080	1041
Register 10:	CAN IF1 Command Mask (CANIF1CMSK), offset 0x024	1042
Register 11:	CAN IF2 Command Mask (CANIF2CMSK), offset 0x084	1042
Register 12:	CAN IF1 Mask 1 (CANIF1MSK1), offset 0x028	1045
Register 13:	CAN IF2 Mask 1 (CANIF2MSK1), offset 0x088	1045
Register 14:	CAN IF1 Mask 2 (CANIF1MSK2), offset 0x02C	1046
Register 15:	CAN IF2 Mask 2 (CANIF2MSK2), offset 0x08C	1046
Register 16:	CAN IF1 Arbitration 1 (CANIF1ARB1), offset 0x030	1048
Register 17:	CAN IF2 Arbitration 1 (CANIF2ARB1), offset 0x090	1048

Register 18:	CAN IF1 Arbitration 2 (CANIF1ARB2), offset 0x034	1049
Register 19:	CAN IF2 Arbitration 2 (CANIF2ARB2), offset 0x094	1049
Register 20:	CAN IF1 Message Control (CANIF1MCTL), offset 0x038	1051
Register 21:	CAN IF2 Message Control (CANIF2MCTL), offset 0x098	1051
Register 22:	CAN IF1 Data A1 (CANIF1DA1), offset 0x03C	1054
Register 23:	CAN IF1 Data A2 (CANIF1DA2), offset 0x040	1054
Register 24:	CAN IF1 Data B1 (CANIF1DB1), offset 0x044	1054
Register 25:	CAN IF1 Data B2 (CANIF1DB2), offset 0x048	1054
Register 26:	CAN IF2 Data A1 (CANIF2DA1), offset 0x09C	1054
Register 27:	CAN IF2 Data A2 (CANIF2DA2), offset 0x0A0	1054
Register 28:	CAN IF2 Data B1 (CANIF2DB1), offset 0x0A4	1054
Register 29:	CAN IF2 Data B2 (CANIF2DB2), offset 0x0A8	1054
Register 30:	CAN Transmission Request 1 (CANTXRQ1), offset 0x100	1055
Register 31:	CAN Transmission Request 2 (CANTXRQ2), offset 0x104	1055
Register 32:	CAN New Data 1 (CANNWDA1), offset 0x120	1056
Register 33:	CAN New Data 2 (CANNWDA2), offset 0x124	1056
Register 34:	CAN Message 1 Interrupt Pending (CANMSG1INT), offset 0x140	1057
Register 35:	CAN Message 2 Interrupt Pending (CANMSG2INT), offset 0x144	1057
Register 36:	CAN Message 1 Valid (CANMSG1VAL), offset 0x160	1058
Register 37:	CAN Message 2 Valid (CANMSG2VAL), offset 0x164	1058
Universal Serial Bus (USB) Controller		1059
Register 1:	USB Device Functional Address (USBFADDR), offset 0x000	1081
Register 2:	USB Power (USBPOWER), offset 0x001	1082
Register 3:	USB Transmit Interrupt Status (USBTXIS), offset 0x002	1085
Register 4:	USB Receive Interrupt Status (USBRXIS), offset 0x004	1087
Register 5:	USB Transmit Interrupt Enable (USBTXIE), offset 0x006	1088
Register 6:	USB Receive Interrupt Enable (USBRXIE), offset 0x008	1090
Register 7:	USB General Interrupt Status (USBIS), offset 0x00A	1091
Register 8:	USB Interrupt Enable (USBIE), offset 0x00B	1094
Register 9:	USB Frame Value (USBFRAME), offset 0x00C	1097
Register 10:	USB Endpoint Index (USBEPIDX), offset 0x00E	1098
Register 11:	USB Test Mode (USBTEST), offset 0x00F	1099
Register 12:	USB FIFO Endpoint 0 (USBFIFO0), offset 0x020	1101
Register 13:	USB FIFO Endpoint 1 (USBFIFO1), offset 0x024	1101
Register 14:	USB FIFO Endpoint 2 (USBFIFO2), offset 0x028	1101
Register 15:	USB FIFO Endpoint 3 (USBFIFO3), offset 0x02C	1101
Register 16:	USB FIFO Endpoint 4 (USBFIFO4), offset 0x030	1101
Register 17:	USB FIFO Endpoint 5 (USBFIFO5), offset 0x034	1101
Register 18:	USB FIFO Endpoint 6 (USBFIFO6), offset 0x038	1101
Register 19:	USB FIFO Endpoint 7 (USBFIFO7), offset 0x03C	1101
Register 20:	USB Device Control (USBDEVCTL), offset 0x060	1102
Register 21:	USB Transmit Dynamic FIFO Sizing (USBTXFIFOSZ), offset 0x062	1104
Register 22:	USB Receive Dynamic FIFO Sizing (USBRXFIFOSZ), offset 0x063	1104
Register 23:	USB Transmit FIFO Start Address (USBTXFIFOADD), offset 0x064	1105
Register 24:	USB Receive FIFO Start Address (USBRXFIFOADD), offset 0x066	1105
Register 25:	USB Connect Timing (USBCONTIM), offset 0x07A	1106
Register 26:	USB OTG VBUS Pulse Timing (USBVPLEN), offset 0x07B	1107
Register 27:	USB Full-Speed Last Transaction to End of Frame Timing (USBFSEOF), offset 0x07D	1108

Register 28:	USB Low-Speed Last Transaction to End of Frame Timing (USBLSEOF), offset 0x07E	1109
Register 29:	USB Transmit Functional Address Endpoint 0 (USBTXFUNCADDR0), offset 0x080	1110
Register 30:	USB Transmit Functional Address Endpoint 1 (USBTXFUNCADDR1), offset 0x088	1110
Register 31:	USB Transmit Functional Address Endpoint 2 (USBTXFUNCADDR2), offset 0x090	1110
Register 32:	USB Transmit Functional Address Endpoint 3 (USBTXFUNCADDR3), offset 0x098	1110
Register 33:	USB Transmit Functional Address Endpoint 4 (USBTXFUNCADDR4), offset 0x0A0	1110
Register 34:	USB Transmit Functional Address Endpoint 5 (USBTXFUNCADDR5), offset 0x0A8	1110
Register 35:	USB Transmit Functional Address Endpoint 6 (USBTXFUNCADDR6), offset 0x0B0	1110
Register 36:	USB Transmit Functional Address Endpoint 7 (USBTXFUNCADDR7), offset 0x0B8	1110
Register 37:	USB Transmit Hub Address Endpoint 0 (USBTXHUBADDR0), offset 0x082	1111
Register 38:	USB Transmit Hub Address Endpoint 1 (USBTXHUBADDR1), offset 0x08A	1111
Register 39:	USB Transmit Hub Address Endpoint 2 (USBTXHUBADDR2), offset 0x092	1111
Register 40:	USB Transmit Hub Address Endpoint 3 (USBTXHUBADDR3), offset 0x09A	1111
Register 41:	USB Transmit Hub Address Endpoint 4 (USBTXHUBADDR4), offset 0x0A2	1111
Register 42:	USB Transmit Hub Address Endpoint 5 (USBTXHUBADDR5), offset 0x0AA	1111
Register 43:	USB Transmit Hub Address Endpoint 6 (USBTXHUBADDR6), offset 0x0B2	1111
Register 44:	USB Transmit Hub Address Endpoint 7 (USBTXHUBADDR7), offset 0x0BA	1111
Register 45:	USB Transmit Hub Port Endpoint 0 (USBTXHUBPORT0), offset 0x083	1112
Register 46:	USB Transmit Hub Port Endpoint 1 (USBTXHUBPORT1), offset 0x08B	1112
Register 47:	USB Transmit Hub Port Endpoint 2 (USBTXHUBPORT2), offset 0x093	1112
Register 48:	USB Transmit Hub Port Endpoint 3 (USBTXHUBPORT3), offset 0x09B	1112
Register 49:	USB Transmit Hub Port Endpoint 4 (USBTXHUBPORT4), offset 0x0A3	1112
Register 50:	USB Transmit Hub Port Endpoint 5 (USBTXHUBPORT5), offset 0x0AB	1112
Register 51:	USB Transmit Hub Port Endpoint 6 (USBTXHUBPORT6), offset 0x0B3	1112
Register 52:	USB Transmit Hub Port Endpoint 7 (USBTXHUBPORT7), offset 0x0BB	1112
Register 53:	USB Receive Functional Address Endpoint 1 (USBRXFUNCADDR1), offset 0x08C	1113
Register 54:	USB Receive Functional Address Endpoint 2 (USBRXFUNCADDR2), offset 0x094	1113
Register 55:	USB Receive Functional Address Endpoint 3 (USBRXFUNCADDR3), offset 0x09C	1113
Register 56:	USB Receive Functional Address Endpoint 4 (USBRXFUNCADDR4), offset 0x0A4	1113
Register 57:	USB Receive Functional Address Endpoint 5 (USBRXFUNCADDR5), offset 0x0AC	1113
Register 58:	USB Receive Functional Address Endpoint 6 (USBRXFUNCADDR6), offset 0x0B4	1113
Register 59:	USB Receive Functional Address Endpoint 7 (USBRXFUNCADDR7), offset 0x0BC	1113
Register 60:	USB Receive Hub Address Endpoint 1 (USBRXHUBADDR1), offset 0x08E	1114
Register 61:	USB Receive Hub Address Endpoint 2 (USBRXHUBADDR2), offset 0x096	1114
Register 62:	USB Receive Hub Address Endpoint 3 (USBRXHUBADDR3), offset 0x09E	1114
Register 63:	USB Receive Hub Address Endpoint 4 (USBRXHUBADDR4), offset 0x0A6	1114
Register 64:	USB Receive Hub Address Endpoint 5 (USBRXHUBADDR5), offset 0x0AE	1114
Register 65:	USB Receive Hub Address Endpoint 6 (USBRXHUBADDR6), offset 0x0B6	1114
Register 66:	USB Receive Hub Address Endpoint 7 (USBRXHUBADDR7), offset 0x0BE	1114
Register 67:	USB Receive Hub Port Endpoint 1 (USBRXHUBPORT1), offset 0x08F	1115
Register 68:	USB Receive Hub Port Endpoint 2 (USBRXHUBPORT2), offset 0x097	1115
Register 69:	USB Receive Hub Port Endpoint 3 (USBRXHUBPORT3), offset 0x09F	1115
Register 70:	USB Receive Hub Port Endpoint 4 (USBRXHUBPORT4), offset 0x0A7	1115
Register 71:	USB Receive Hub Port Endpoint 5 (USBRXHUBPORT5), offset 0x0AF	1115
Register 72:	USB Receive Hub Port Endpoint 6 (USBRXHUBPORT6), offset 0x0B7	1115
Register 73:	USB Receive Hub Port Endpoint 7 (USBRXHUBPORT7), offset 0x0BF	1115
Register 74:	USB Maximum Transmit Data Endpoint 1 (USBTXMAXP1), offset 0x110	1116
Register 75:	USB Maximum Transmit Data Endpoint 2 (USBTXMAXP2), offset 0x120	1116

Register 76:	USB Maximum Transmit Data Endpoint 3 (USBTXMAXP3), offset 0x130	1116
Register 77:	USB Maximum Transmit Data Endpoint 4 (USBTXMAXP4), offset 0x140	1116
Register 78:	USB Maximum Transmit Data Endpoint 5 (USBTXMAXP5), offset 0x150	1116
Register 79:	USB Maximum Transmit Data Endpoint 6 (USBTXMAXP6), offset 0x160	1116
Register 80:	USB Maximum Transmit Data Endpoint 7 (USBTXMAXP7), offset 0x170	1116
Register 81:	USB Control and Status Endpoint 0 Low (USBCSRL0), offset 0x102	1117
Register 82:	USB Control and Status Endpoint 0 High (USBCSRH0), offset 0x103	1121
Register 83:	USB Receive Byte Count Endpoint 0 (USBCOUNT0), offset 0x108	1123
Register 84:	USB Type Endpoint 0 (USBTYPE0), offset 0x10A	1124
Register 85:	USB NAK Limit (USBNAKLMT), offset 0x10B	1125
Register 86:	USB Transmit Control and Status Endpoint 1 Low (USBTXCSRL1), offset 0x112	1126
Register 87:	USB Transmit Control and Status Endpoint 2 Low (USBTXCSRL2), offset 0x122	1126
Register 88:	USB Transmit Control and Status Endpoint 3 Low (USBTXCSRL3), offset 0x132	1126
Register 89:	USB Transmit Control and Status Endpoint 4 Low (USBTXCSRL4), offset 0x142	1126
Register 90:	USB Transmit Control and Status Endpoint 5 Low (USBTXCSRL5), offset 0x152	1126
Register 91:	USB Transmit Control and Status Endpoint 6 Low (USBTXCSRL6), offset 0x162	1126
Register 92:	USB Transmit Control and Status Endpoint 7 Low (USBTXCSRL7), offset 0x172	1126
Register 93:	USB Transmit Control and Status Endpoint 1 High (USBTXCSRH1), offset 0x113	1130
Register 94:	USB Transmit Control and Status Endpoint 2 High (USBTXCSRH2), offset 0x123	1130
Register 95:	USB Transmit Control and Status Endpoint 3 High (USBTXCSRH3), offset 0x133	1130
Register 96:	USB Transmit Control and Status Endpoint 4 High (USBTXCSRH4), offset 0x143	1130
Register 97:	USB Transmit Control and Status Endpoint 5 High (USBTXCSRH5), offset 0x153	1130
Register 98:	USB Transmit Control and Status Endpoint 6 High (USBTXCSRH6), offset 0x163	1130
Register 99:	USB Transmit Control and Status Endpoint 7 High (USBTXCSRH7), offset 0x173	1130
Register 100:	USB Maximum Receive Data Endpoint 1 (USBRXMAXP1), offset 0x114	1134
Register 101:	USB Maximum Receive Data Endpoint 2 (USBRXMAXP2), offset 0x124	1134
Register 102:	USB Maximum Receive Data Endpoint 3 (USBRXMAXP3), offset 0x134	1134
Register 103:	USB Maximum Receive Data Endpoint 4 (USBRXMAXP4), offset 0x144	1134
Register 104:	USB Maximum Receive Data Endpoint 5 (USBRXMAXP5), offset 0x154	1134
Register 105:	USB Maximum Receive Data Endpoint 6 (USBRXMAXP6), offset 0x164	1134
Register 106:	USB Maximum Receive Data Endpoint 7 (USBRXMAXP7), offset 0x174	1134
Register 107:	USB Receive Control and Status Endpoint 1 Low (USBRXCSRL1), offset 0x116	1135
Register 108:	USB Receive Control and Status Endpoint 2 Low (USBRXCSRL2), offset 0x126	1135
Register 109:	USB Receive Control and Status Endpoint 3 Low (USBRXCSRL3), offset 0x136	1135
Register 110:	USB Receive Control and Status Endpoint 4 Low (USBRXCSRL4), offset 0x146	1135
Register 111:	USB Receive Control and Status Endpoint 5 Low (USBRXCSRL5), offset 0x156	1135
Register 112:	USB Receive Control and Status Endpoint 6 Low (USBRXCSRL6), offset 0x166	1135
Register 113:	USB Receive Control and Status Endpoint 7 Low (USBRXCSRL7), offset 0x176	1135
Register 114:	USB Receive Control and Status Endpoint 1 High (USBRXCSRH1), offset 0x117	1140
Register 115:	USB Receive Control and Status Endpoint 2 High (USBRXCSRH2), offset 0x127	1140
Register 116:	USB Receive Control and Status Endpoint 3 High (USBRXCSRH3), offset 0x137	1140
Register 117:	USB Receive Control and Status Endpoint 4 High (USBRXCSRH4), offset 0x147	1140
Register 118:	USB Receive Control and Status Endpoint 5 High (USBRXCSRH5), offset 0x157	1140
Register 119:	USB Receive Control and Status Endpoint 6 High (USBRXCSRH6), offset 0x167	1140
Register 120:	USB Receive Control and Status Endpoint 7 High (USBRXCSRH7), offset 0x177	1140
Register 121:	USB Receive Byte Count Endpoint 1 (USBRXCOUNT1), offset 0x118	1144
Register 122:	USB Receive Byte Count Endpoint 2 (USBRXCOUNT2), offset 0x128	1144
Register 123:	USB Receive Byte Count Endpoint 3 (USBRXCOUNT3), offset 0x138	1144

Register 124: USB Receive Byte Count Endpoint 4 (USBRXCOUNT4), offset 0x148	1144
Register 125: USB Receive Byte Count Endpoint 5 (USBRXCOUNT5), offset 0x158	1144
Register 126: USB Receive Byte Count Endpoint 6 (USBRXCOUNT6), offset 0x168	1144
Register 127: USB Receive Byte Count Endpoint 7 (USBRXCOUNT7), offset 0x178	1144
Register 128: USB Host Transmit Configure Type Endpoint 1 (USBTXTYPE1), offset 0x11A	1145
Register 129: USB Host Transmit Configure Type Endpoint 2 (USBTXTYPE2), offset 0x12A	1145
Register 130: USB Host Transmit Configure Type Endpoint 3 (USBTXTYPE3), offset 0x13A	1145
Register 131: USB Host Transmit Configure Type Endpoint 4 (USBTXTYPE4), offset 0x14A	1145
Register 132: USB Host Transmit Configure Type Endpoint 5 (USBTXTYPE5), offset 0x15A	1145
Register 133: USB Host Transmit Configure Type Endpoint 6 (USBTXTYPE6), offset 0x16A	1145
Register 134: USB Host Transmit Configure Type Endpoint 7 (USBTXTYPE7), offset 0x17A	1145
Register 135: USB Host Transmit Interval Endpoint 1 (USBTXINTERVAL1), offset 0x11B	1147
Register 136: USB Host Transmit Interval Endpoint 2 (USBTXINTERVAL2), offset 0x12B	1147
Register 137: USB Host Transmit Interval Endpoint 3 (USBTXINTERVAL3), offset 0x13B	1147
Register 138: USB Host Transmit Interval Endpoint 4 (USBTXINTERVAL4), offset 0x14B	1147
Register 139: USB Host Transmit Interval Endpoint 5 (USBTXINTERVAL5), offset 0x15B	1147
Register 140: USB Host Transmit Interval Endpoint 6 (USBTXINTERVAL6), offset 0x16B	1147
Register 141: USB Host Transmit Interval Endpoint 7 (USBTXINTERVAL7), offset 0x17B	1147
Register 142: USB Host Configure Receive Type Endpoint 1 (USBRXTYPE1), offset 0x11C	1148
Register 143: USB Host Configure Receive Type Endpoint 2 (USBRXTYPE2), offset 0x12C	1148
Register 144: USB Host Configure Receive Type Endpoint 3 (USBRXTYPE3), offset 0x13C	1148
Register 145: USB Host Configure Receive Type Endpoint 4 (USBRXTYPE4), offset 0x14C	1148
Register 146: USB Host Configure Receive Type Endpoint 5 (USBRXTYPE5), offset 0x15C	1148
Register 147: USB Host Configure Receive Type Endpoint 6 (USBRXTYPE6), offset 0x16C	1148
Register 148: USB Host Configure Receive Type Endpoint 7 (USBRXTYPE7), offset 0x17C	1148
Register 149: USB Host Receive Polling Interval Endpoint 1 (USBRXINTERVAL1), offset 0x11D	1150
Register 150: USB Host Receive Polling Interval Endpoint 2 (USBRXINTERVAL2), offset 0x12D	1150
Register 151: USB Host Receive Polling Interval Endpoint 3 (USBRXINTERVAL3), offset 0x13D	1150
Register 152: USB Host Receive Polling Interval Endpoint 4 (USBRXINTERVAL4), offset 0x14D	1150
Register 153: USB Host Receive Polling Interval Endpoint 5 (USBRXINTERVAL5), offset 0x15D	1150
Register 154: USB Host Receive Polling Interval Endpoint 6 (USBRXINTERVAL6), offset 0x16D	1150
Register 155: USB Host Receive Polling Interval Endpoint 7 (USBRXINTERVAL7), offset 0x17D	1150
Register 156: USB Request Packet Count in Block Transfer Endpoint 1 (USBRQPKTCOUNT1), offset 0x304	1151
Register 157: USB Request Packet Count in Block Transfer Endpoint 2 (USBRQPKTCOUNT2), offset 0x308	1151
Register 158: USB Request Packet Count in Block Transfer Endpoint 3 (USBRQPKTCOUNT3), offset 0x30C	1151
Register 159: USB Request Packet Count in Block Transfer Endpoint 4 (USBRQPKTCOUNT4), offset 0x310	1151
Register 160: USB Request Packet Count in Block Transfer Endpoint 5 (USBRQPKTCOUNT5), offset 0x314	1151
Register 161: USB Request Packet Count in Block Transfer Endpoint 6 (USBRQPKTCOUNT6), offset 0x318	1151
Register 162: USB Request Packet Count in Block Transfer Endpoint 7 (USBRQPKTCOUNT7), offset 0x31C	1151
Register 163: USB Receive Double Packet Buffer Disable (USBRXDPKTBUFDIS), offset 0x340	1152
Register 164: USB Transmit Double Packet Buffer Disable (USBTXDPKTBUFDIS), offset 0x342	1153
Register 165: USB External Power Control (USBEPCC), offset 0x400	1154

Register 166:	USB External Power Control Raw Interrupt Status (USBEPCRIS), offset 0x404	1157
Register 167:	USB External Power Control Interrupt Mask (USBEPCIM), offset 0x408	1158
Register 168:	USB External Power Control Interrupt Status and Clear (USBEPCISC), offset 0x40C	1159
Register 169:	USB Device RESUME Raw Interrupt Status (USBDRRIS), offset 0x410	1160
Register 170:	USB Device RESUME Interrupt Mask (USBDRIM), offset 0x414	1161
Register 171:	USB Device RESUME Interrupt Status and Clear (USBDRISC), offset 0x418	1162
Register 172:	USB General-Purpose Control and Status (USBGPCS), offset 0x41C	1163
Register 173:	USB VBUS Droop Control (USBVDC), offset 0x430	1164
Register 174:	USB VBUS Droop Control Raw Interrupt Status (USBVDCRIS), offset 0x434	1165
Register 175:	USB VBUS Droop Control Interrupt Mask (USBVDCIM), offset 0x438	1166
Register 176:	USB VBUS Droop Control Interrupt Status and Clear (USBVDCISC), offset 0x43C	1167
Register 177:	USB ID Valid Detect Raw Interrupt Status (USBIDVRIS), offset 0x444	1168
Register 178:	USB ID Valid Detect Interrupt Mask (USBIDVIM), offset 0x448	1169
Register 179:	USB ID Valid Detect Interrupt Status and Clear (USBIDVISC), offset 0x44C	1170
Register 180:	USB DMA Select (USBDMASEL), offset 0x450	1171
Register 181:	USB Peripheral Properties (USBPP), offset 0xFC0	1173
Analog Comparators		1174
Register 1:	Analog Comparator Masked Interrupt Status (ACMIS), offset 0x000	1181
Register 2:	Analog Comparator Raw Interrupt Status (ACRIS), offset 0x004	1182
Register 3:	Analog Comparator Interrupt Enable (ACINTEN), offset 0x008	1183
Register 4:	Analog Comparator Reference Voltage Control (ACREFCTL), offset 0x010	1184
Register 5:	Analog Comparator Status 0 (ACSTAT0), offset 0x020	1185
Register 6:	Analog Comparator Status 1 (ACSTAT1), offset 0x040	1185
Register 7:	Analog Comparator Control 0 (ACCTL0), offset 0x024	1186
Register 8:	Analog Comparator Control 1 (ACCTL1), offset 0x044	1186
Register 9:	Analog Comparator Peripheral Properties (ACMPPP), offset 0xFC0	1188
Pulse Width Modulator (PWM)		1189
Register 1:	PWM Master Control (PWMCTL), offset 0x000	1203
Register 2:	PWM Time Base Sync (PWMSYNC), offset 0x004	1205
Register 3:	PWM Output Enable (PWMENABLE), offset 0x008	1206
Register 4:	PWM Output Inversion (PWMINVERT), offset 0x00C	1208
Register 5:	PWM Output Fault (PWMFAULT), offset 0x010	1210
Register 6:	PWM Interrupt Enable (PWMINTEN), offset 0x014	1212
Register 7:	PWM Raw Interrupt Status (PWMRIS), offset 0x018	1214
Register 8:	PWM Interrupt Status and Clear (PWMISC), offset 0x01C	1217
Register 9:	PWM Status (PWMSTATUS), offset 0x020	1220
Register 10:	PWM Fault Condition Value (PWMFAULTVAL), offset 0x024	1222
Register 11:	PWM Enable Update (PWMENUUPD), offset 0x028	1224
Register 12:	PWM0 Control (PWM0CTL), offset 0x040	1228
Register 13:	PWM1 Control (PWM1CTL), offset 0x080	1228
Register 14:	PWM2 Control (PWM2CTL), offset 0x0C0	1228
Register 15:	PWM3 Control (PWM3CTL), offset 0x100	1228
Register 16:	PWM0 Interrupt and Trigger Enable (PWM0INTEN), offset 0x044	1233
Register 17:	PWM1 Interrupt and Trigger Enable (PWM1INTEN), offset 0x084	1233
Register 18:	PWM2 Interrupt and Trigger Enable (PWM2INTEN), offset 0x0C4	1233
Register 19:	PWM3 Interrupt and Trigger Enable (PWM3INTEN), offset 0x104	1233
Register 20:	PWM0 Raw Interrupt Status (PWM0RIS), offset 0x048	1236
Register 21:	PWM1 Raw Interrupt Status (PWM1RIS), offset 0x088	1236

Register 22:	PWM2 Raw Interrupt Status (PWM2RIS), offset 0x0C8	1236
Register 23:	PWM3 Raw Interrupt Status (PWM3RIS), offset 0x108	1236
Register 24:	PWM0 Interrupt Status and Clear (PWM0ISC), offset 0x04C	1238
Register 25:	PWM1 Interrupt Status and Clear (PWM1ISC), offset 0x08C	1238
Register 26:	PWM2 Interrupt Status and Clear (PWM2ISC), offset 0x0CC	1238
Register 27:	PWM3 Interrupt Status and Clear (PWM3ISC), offset 0x10C	1238
Register 28:	PWM0 Load (PWM0LOAD), offset 0x050	1240
Register 29:	PWM1 Load (PWM1LOAD), offset 0x090	1240
Register 30:	PWM2 Load (PWM2LOAD), offset 0x0D0	1240
Register 31:	PWM3 Load (PWM3LOAD), offset 0x110	1240
Register 32:	PWM0 Counter (PWM0COUNT), offset 0x054	1241
Register 33:	PWM1 Counter (PWM1COUNT), offset 0x094	1241
Register 34:	PWM2 Counter (PWM2COUNT), offset 0x0D4	1241
Register 35:	PWM3 Counter (PWM3COUNT), offset 0x114	1241
Register 36:	PWM0 Compare A (PWM0CMPA), offset 0x058	1242
Register 37:	PWM1 Compare A (PWM1CMPA), offset 0x098	1242
Register 38:	PWM2 Compare A (PWM2CMPA), offset 0x0D8	1242
Register 39:	PWM3 Compare A (PWM3CMPA), offset 0x118	1242
Register 40:	PWM0 Compare B (PWM0CMPB), offset 0x05C	1243
Register 41:	PWM1 Compare B (PWM1CMPB), offset 0x09C	1243
Register 42:	PWM2 Compare B (PWM2CMPB), offset 0x0DC	1243
Register 43:	PWM3 Compare B (PWM3CMPB), offset 0x11C	1243
Register 44:	PWM0 Generator A Control (PWM0GENA), offset 0x060	1244
Register 45:	PWM1 Generator A Control (PWM1GENA), offset 0x0A0	1244
Register 46:	PWM2 Generator A Control (PWM2GENA), offset 0x0E0	1244
Register 47:	PWM3 Generator A Control (PWM3GENA), offset 0x120	1244
Register 48:	PWM0 Generator B Control (PWM0GENB), offset 0x064	1247
Register 49:	PWM1 Generator B Control (PWM1GENB), offset 0x0A4	1247
Register 50:	PWM2 Generator B Control (PWM2GENB), offset 0x0E4	1247
Register 51:	PWM3 Generator B Control (PWM3GENB), offset 0x124	1247
Register 52:	PWM0 Dead-Band Control (PWM0DBCTL), offset 0x068	1250
Register 53:	PWM1 Dead-Band Control (PWM1DBCTL), offset 0x0A8	1250
Register 54:	PWM2 Dead-Band Control (PWM2DBCTL), offset 0x0E8	1250
Register 55:	PWM3 Dead-Band Control (PWM3DBCTL), offset 0x128	1250
Register 56:	PWM0 Dead-Band Rising-Edge Delay (PWM0DBRISE), offset 0x06C	1251
Register 57:	PWM1 Dead-Band Rising-Edge Delay (PWM1DBRISE), offset 0x0AC	1251
Register 58:	PWM2 Dead-Band Rising-Edge Delay (PWM2DBRISE), offset 0x0EC	1251
Register 59:	PWM3 Dead-Band Rising-Edge Delay (PWM3DBRISE), offset 0x12C	1251
Register 60:	PWM0 Dead-Band Falling-Edge-Delay (PWM0DBFALL), offset 0x070	1252
Register 61:	PWM1 Dead-Band Falling-Edge-Delay (PWM1DBFALL), offset 0x0B0	1252
Register 62:	PWM2 Dead-Band Falling-Edge-Delay (PWM2DBFALL), offset 0x0F0	1252
Register 63:	PWM3 Dead-Band Falling-Edge-Delay (PWM3DBFALL), offset 0x130	1252
Register 64:	PWM0 Fault Source 0 (PWM0FLTSRC0), offset 0x074	1253
Register 65:	PWM1 Fault Source 0 (PWM1FLTSRC0), offset 0x0B4	1253
Register 66:	PWM2 Fault Source 0 (PWM2FLTSRC0), offset 0x0F4	1253
Register 67:	PWM3 Fault Source 0 (PWM3FLTSRC0), offset 0x134	1253
Register 68:	PWM0 Fault Source 1 (PWM0FLTSRC1), offset 0x078	1255
Register 69:	PWM1 Fault Source 1 (PWM1FLTSRC1), offset 0x0B8	1255

Register 70:	PWM2 Fault Source 1 (PWM2FLTSRC1), offset 0x0F8	1255
Register 71:	PWM3 Fault Source 1 (PWM3FLTSRC1), offset 0x138	1255
Register 72:	PWM0 Minimum Fault Period (PWM0MINFLTPER), offset 0x07C	1258
Register 73:	PWM1 Minimum Fault Period (PWM1MINFLTPER), offset 0x0BC	1258
Register 74:	PWM2 Minimum Fault Period (PWM2MINFLTPER), offset 0x0FC	1258
Register 75:	PWM3 Minimum Fault Period (PWM3MINFLTPER), offset 0x13C	1258
Register 76:	PWM0 Fault Pin Logic Sense (PWM0FLTSEN), offset 0x800	1259
Register 77:	PWM1 Fault Pin Logic Sense (PWM1FLTSEN), offset 0x880	1259
Register 78:	PWM2 Fault Pin Logic Sense (PWM2FLTSEN), offset 0x900	1259
Register 79:	PWM3 Fault Pin Logic Sense (PWM3FLTSEN), offset 0x980	1259
Register 80:	PWM0 Fault Status 0 (PWM0FLTSTAT0), offset 0x804	1260
Register 81:	PWM1 Fault Status 0 (PWM1FLTSTAT0), offset 0x884	1260
Register 82:	PWM2 Fault Status 0 (PWM2FLTSTAT0), offset 0x904	1260
Register 83:	PWM3 Fault Status 0 (PWM3FLTSTAT0), offset 0x984	1260
Register 84:	PWM0 Fault Status 1 (PWM0FLTSTAT1), offset 0x808	1262
Register 85:	PWM1 Fault Status 1 (PWM1FLTSTAT1), offset 0x888	1262
Register 86:	PWM2 Fault Status 1 (PWM2FLTSTAT1), offset 0x908	1262
Register 87:	PWM3 Fault Status 1 (PWM3FLTSTAT1), offset 0x988	1262
Register 88:	PWM Peripheral Properties (PWMPP), offset 0xFC0	1265
Register 89:	PWM Peripheral Configuration (PWMPC), offset 0xFC4	1267
Quadrature Encoder Interface (QEI)		1268
Register 1:	QEI Control (QEICTL), offset 0x000	1274
Register 2:	QEI Status (QEISTAT), offset 0x004	1277
Register 3:	QEI Position (QEIPOS), offset 0x008	1278
Register 4:	QEI Maximum Position (QEIMAXPOS), offset 0x00C	1279
Register 5:	QEI Timer Load (QEILOAD), offset 0x010	1280
Register 6:	QEI Timer (QEITIME), offset 0x014	1281
Register 7:	QEI Velocity Counter (QEICOUNT), offset 0x018	1282
Register 8:	QEI Velocity (QEISPEED), offset 0x01C	1283
Register 9:	QEI Interrupt Enable (QEIINTEN), offset 0x020	1284
Register 10:	QEI Raw Interrupt Status (QEIRIS), offset 0x024	1286
Register 11:	QEI Interrupt Status and Clear (QEISC), offset 0x028	1288

Revision History

The revision history table notes changes made between the indicated revisions of the LM4F231H5QR data sheet.

Table 1. Revision History

Date	Revision	Description
April 2012	12457.2480	<ul style="list-style-type: none"> ■ Document revision number is now auto-generated and indicates the revision of the source files. ■ In the JTAG chapter, clarified that the "Recovering a Locked Microcontroller" procedure erases EEPROM and returns its wear-leveling counters to factory default values. ■ In the System Control chapter, reorganized registers to group legacy registers at the end of the chapter. ■ In the uDMA chapter, in the "uDMA Channel Assignments" and "Request Type Support" tables, corrected to show uDMA support for burst requests from the general-purpose timer, not single requests. ■ In the SSI chapter, added the <code>SLBY6</code> bit to the SSI Control 1 (SSICR1) register. This allows the system clock to operate at least 6 times faster (overriding 12 times faster normally) than <code>SSICLK</code>. ■ In the I²C chapter, clarified description of Quick Command. ■ In the Operating Characteristics chapter, deleted the Maximum power dissipation parameter from the "Thermal Characteristics" table. ■ In the Electrical Characteristics chapter: <ul style="list-style-type: none"> – Removed pending characterization notes in a number of tables where data has been reviewed. – In the Power Characteristics table, adjusted the minimum, nominal, and maximum values for POR and BOR thresholds. – In the Main Oscillator Input Characteristics table, adjusted the maximum value for the main oscillator startup time. – Added Crystal Parameters table. – In the Flash Memory Characteristics table, adjusted the maximum values for <code>T_{PROG64}</code> and <code>T_{ERASE}</code>. – In the GPIO Module Characteristics table, adjusted the values for the GPIO rise and fall times. – In the ADC Electrical Characteristics table, updated Max value for the ADC input common mode voltage parameter, and adjusted system performance parameter values. – In the SSI Characteristics table, adjusted values for <code>SSIClk</code> rise and fall times. – In Preliminary Current Consumption table, updated Nom value for Deep-sleep mode parameter. ■ Additional minor data sheet clarifications and corrections.
March 2012	12013	<ul style="list-style-type: none"> ■ In Cortex-M4 Peripherals chapter: <ul style="list-style-type: none"> – Corrected missing bits in Interrupt 128-138 Set Enable (EN4), Interrupt 128-138 Clear Enable (DIS4), Interrupt 128-138 Set Pending (PEND4), Interrupt 128-138 Clear Pending (UNPEND4), and Interrupt 128-138 Active Bit (ACTIVE4) registers. – Added missing Interrupt 132-135 Priority (PRI33) and Interrupt 136-138 Priority (PRI34) registers. ■ In the System Control chapter,

Table 1. Revision History (continued)

Date	Revision	Description
		<ul style="list-style-type: none"> – Corrected Power Architecture figure. – Added note that the configuration of the system clock must not be changed while an EEPROM operation is in process. – Corrected to 1 the reset for bit 27 in the Device Identification 0 (DID0) register. – Clarified the Software Reset (SRx), Run Mode Clock Gating Control (RCGCx), Sleep Mode Clock Gating Control (SCGCx), Deep-Sleep Mode Clock Gating Control (DCGCx), Power Control (PCx) and Peripheral Ready (PRx) registers by removing those bits without meaning because that feature is not present. Conversely, the Peripheral Present (PPx) registers show bit fields available for all devices in this family, with a 0 indicating the feature is not present. ■ In the Timer chapter, noted that if PWM output inversion is enabled, edge detection interrupt behavior is reversed. ■ In the Watchdog Timers chapter, added information on servicing the watchdog timer to the Initialization and Configuration section. ■ In the ADC chapter: <ul style="list-style-type: none"> – Corrected figure "ADC Input Equivalency Diagram". – Changed the voltage reference internal signal names to VREFP and VREFN. – Clarified "Differential Sampling" section. – Corrected figure "Internal Temperature Sensor Characteristic". – Corrected PSn bit field locations in ADC Trigger Source Select (ADCTSEL) register. – Corrected resets for ADC Control (ADCCTL) and ADC Sample Sequence Control 3 (ADCSSCTL3) registers. ■ In the UART chapter: <ul style="list-style-type: none"> – Added note to UART LIN Timer (UARTLTIM) register that if the PIOSC is being used as the UART baud clock, the value in this register should be read twice to ensure the data is correct. – Removed RANGE bit from the UART 9-Bit Self Address Mask (UART9BITAMASK) register. – Corrected CS bit field values in the UART Clock Configuration (UARTCC) register. ■ In the SSI chapter: <ul style="list-style-type: none"> – Clarified the steps in the initialization and configuration section. – Corrected CS bit field values in the SSI Clock Configuration (SSICC) register. ■ In the I²C chapter: <ul style="list-style-type: none"> – Clarified the operation of the clock low timeout. – Added information about high-speed operation and Fast Plus mode. – Corrected reset for I²C Master Bus Monitor (I2CMBMON) register. ■ In the USB chapter, corrected reset for ECNT bit in USB Peripheral Properties (USBPP) register. ■ In the Analog Comparators chapter: <ul style="list-style-type: none"> – Rewrote Internal Reference Programming section.

Table 1. Revision History (continued)

Date	Revision	Description
		<ul style="list-style-type: none"> – Corrected bit description for RNG in the Analog Comparator Reference Voltage Control (ACREFCTL) register. ■ In the Signal Tables chapter, deleted erroneously included LPC signals. ■ In the Electrical Characteristics chapter: <ul style="list-style-type: none"> – Clarified GPIO pad operation and specifications, including ESD protection, V_{OH}, V_{OL}, input hysteresis, input leakage, and injection current. – Corrected Nom value for TCK clock Low and High time. – Clarified reset timing when in Deep-sleep mode. – Corrected frequency range for the internal 30-kHz oscillator. – Added values to the table "GPIO Module Characteristics". – Added specifications for the ADC when using the internal reference. – Added specification for ADC input common mode voltage when in differential mode. – Added specification for current consumption on VDDA. ■ Additional minor data sheet clarifications and corrections.
November 2011	11003	<ul style="list-style-type: none"> ■ Re-organized Architectural Overview chapter. ■ In the System Control chapter: <ul style="list-style-type: none"> – Corrected reset value for Run Mode Clock Gating Control Register 0 (RCGC0) register. – Corrected reset for the System Properties (SYSPROP) register. – Removed TPSW bit from Non-Volatile Memory Information (NVMSTAT) register as the ROM Software Map (ROMSWMAP) register contains this information. ■ Changed bit names in System Exception Raw Interrupt Status (SYSEXCRIS), System Exception Interrupt Mask (SYSEXCIM), System Exception Masked Interrupt Status (SYSEXCMS), and System Exception Interrupt Clear (SYSEXCIC) registers to indicate they are for floating-point exceptions. ■ Removed references to RTCCLK as it is not supported on this device. ■ In the Internal Memory chapter, clarified programming and use of the non-volatile registers, including corrections to the Boot Configuration (BOOTCFG) and User Register n (USER_REGn) registers. ■ In the GPIO chapter, corrected table "GPIO Pins With Non-Zero Reset Values". ■ In the General-Purpose Timers chapter, added clarifications on timer operation. ■ In the UART chapter, clarified interrupt behavior. ■ In the I²C chapter: <ul style="list-style-type: none"> – Added content for Fast-Mode Plus (1 Mbps) mode and High-Speed mode (3.33 Mbps), correcting the reset value of the Device Capabilities 2 (DC2), I²C Master Control/Status (I2CMCS), and I²C Peripheral Properties (I2CPP) registers. – Corrected reset for the I²C Master Control/Status (I2CMCS) register. – Added the HSTPR bit to the I²C Master Timer Period (I2CMTPR) register. – Added the I²C Peripheral Configuration (I2CPC) register. ■ In the USB chapter: <ul style="list-style-type: none"> – Corrected description for the USB Device RESUME Interrupt Mask (USBDRIM) register. ■ In the Analog Comparators chapter:

Table 1. Revision History (continued)

Date	Revision	Description
		<ul style="list-style-type: none">- Corrected table "Internal Reference Voltage and ACREFTL Field Values".- Corrected bit fields in the Analog Comparator Peripheral Properties (ACMPPP) register.■ In the Electrical Characteristics chapter:<ul style="list-style-type: none">- Clarified load capacitance equations.- Corrected values in table "Analog Comparator Voltage Reference Characteristics".■ Additional minor data sheet clarifications and corrections.
September 2011	10502	Started tracking revision history.

About This Document

This data sheet provides reference information for the LM4F231H5QR microcontroller, describing the functional blocks of the system-on-chip (SoC) device designed around the ARM® Cortex™-M4F core.

Audience

This manual is intended for system software developers, hardware designers, and application developers.

About This Manual

This document is organized into sections that correspond to each major feature.

Related Documents

The following related documents are available on the Stellaris® web site at www.ti.com/stellaris:

- *Stellaris® Errata*
- *ARM® Cortex™-M4 Errata*
- *Cortex™-M3/M4 Instruction Set Technical User's Manual*
- *Stellaris® Boot Loader User's Guide*
- *Stellaris® Graphics Library User's Guide*
- *Stellaris® Peripheral Driver Library User's Guide*
- *Stellaris® ROM User's Guide*
- *Stellaris® USB Library User's Guide*

The following related documents are also referenced:

- *ARM® Debug Interface V5 Architecture Specification*
- *ARM® Embedded Trace Macrocell Architecture Specification*
- *IEEE Standard 1149.1-Test Access Port and Boundary-Scan Architecture*

This documentation list was current as of publication date. Please check the web site for additional documentation, including application notes and white papers.

Documentation Conventions

This document uses the conventions shown in Table 2 on page 43.

Table 2. Documentation Conventions

Notation	Meaning
General Register Notation	
REGISTER	APB registers are indicated in uppercase bold. For example, PBORCTL is the Power-On and Brown-Out Reset Control register. If a register name contains a lowercase n, it represents more than one register. For example, SRCRn represents any (or all) of the three Software Reset Control registers: SRCR0 , SRCR1 , and SRCR2 .
bit	A single bit in a register.
bit field	Two or more consecutive and related bits.
offset 0xnnn	A hexadecimal increment to a register's address, relative to that module's base address as specified in Table 2-4 on page 93.
Register N	Registers are numbered consecutively throughout the document to aid in referencing them. The register number has no meaning to software.
reserved	Register bits marked <i>reserved</i> are reserved for future use. In most cases, reserved bits are set to 0; however, user software should not rely on the value of a reserved bit. To provide software compatibility with future products, the value of a reserved bit should be preserved across a read-modify-write operation.
yy:xx	The range of register bits inclusive from xx to yy. For example, 31:15 means bits 15 through 31 in that register.
Register Bit/Field Types	
RC	Software can read this field. The bit or field is cleared by hardware after reading the bit/field.
RO	Software can read this field. Always write the chip reset value.
R/W	Software can read or write this field.
R/WC	Software can read or write this field. Writing to it with any value clears the register.
R/W1C	Software can read or write this field. A write of a 0 to a W1C bit does not affect the bit value in the register. A write of a 1 clears the value of the bit in the register; the remaining bits remain unchanged. This register type is primarily used for clearing interrupt status bits where the read operation provides the interrupt status and the write of the read value clears only the interrupts being reported at the time the register was read.
R/W1S	Software can read or write a 1 to this field. A write of a 0 to a R/W1S bit does not affect the bit value in the register.
W1C	Software can write this field. A write of a 0 to a W1C bit does not affect the bit value in the register. A write of a 1 clears the value of the bit in the register; the remaining bits remain unchanged. A read of the register returns no meaningful data. This register is typically used to clear the corresponding bit in an interrupt register.
WO	Only a write by software is valid; a read of the register returns no meaningful data.
Register Bit/Field Reset Value	
0	Bit cleared to 0 on chip reset.
1	Bit set to 1 on chip reset.
-	Nondeterministic.
Pin/Signal Notation	
[]	Pin alternate function; a pin defaults to the signal without the brackets.
pin	Refers to the physical connection on the package.
signal	Refers to the electrical signal encoding of a pin.

Table 2. Documentation Conventions (continued)

Notation	Meaning
assert a signal	Change the value of the signal from the logically False state to the logically True state. For active High signals, the asserted signal value is 1 (High); for active Low signals, the asserted signal value is 0 (Low). The active polarity (High or Low) is defined by the signal name (see <code>SIGNAL</code> and <code>$\overline{\text{SIGNAL}}$</code> below).
deassert a signal	Change the value of the signal from the logically True state to the logically False state.
<code>$\overline{\text{SIGNAL}}$</code>	Signal names are in uppercase and in the Courier font. An overbar on a signal name indicates that it is active Low. To assert <code>$\overline{\text{SIGNAL}}$</code> is to drive it Low; to deassert <code>$\overline{\text{SIGNAL}}$</code> is to drive it High.
<code>SIGNAL</code>	Signal names are in uppercase and in the Courier font. An active High signal has no overbar. To assert <code>SIGNAL</code> is to drive it High; to deassert <code>SIGNAL</code> is to drive it Low.
Numbers	
X	An uppercase X indicates any of several values is allowed, where X can be any legal pattern. For example, a binary value of 0X00 can be either 0100 or 0000, a hex value of 0xX is 0x0 or 0x1, and so on.
0x	Hexadecimal numbers have a prefix of 0x. For example, 0x00FF is the hexadecimal number FF. All other numbers within register tables are assumed to be binary. Within conceptual information, binary numbers are indicated with a b suffix, for example, 1011b, and decimal numbers are written without a prefix or suffix.

1 Architectural Overview

Texas Instruments is the industry leader in bringing 32-bit capabilities and the full benefits of ARM® Cortex™-M-based microcontrollers to the broadest reach of the microcontroller market. For current users of 8- and 16-bit MCUs, Stellaris® with Cortex-M offers a direct path to the strongest ecosystem of development tools, software and knowledge in the industry. Designers who migrate to Stellaris benefit from great tools, small code footprint and outstanding performance. Even more important, designers can enter the ARM ecosystem with full confidence in a compatible roadmap from \$1 to 1 GHz. With blazingly-fast responsiveness, Thumb-2 technology combines both 16-bit and 32-bit instructions to deliver the best balance of code density and performance. Thumb-2 uses 26 percent less memory than pure 32-bit code to reduce system cost while delivering 25 percent better performance. The Texas Instruments Stellaris family of microcontrollers brings high-performance 32-bit computing to cost-sensitive embedded microcontroller applications.

This chapter contains an overview of the Stellaris LM4F series of microcontrollers as well as details on the LM4F231H5QR microcontroller:

- “Stellaris LM4F Series Overview” on page 45
- “LM4F231H5QR Microcontroller Overview” on page 48
- “LM4F231H5QR Microcontroller Features” on page 51
- “LM4F231H5QR Microcontroller Hardware Details” on page 69

1.1 Stellaris LM4F Series Overview

The Stellaris LM4F series of ARM Cortex-M4 microcontrollers provides top performance and advanced integration. The product family is positioned for cost-conscious applications requiring significant control processing and connectivity capabilities such as:

- Low power, hand-held smart devices
- Gaming equipment
- Home and commercial site monitoring and control
- Motion control
- Medical instrumentation
- Test and measurement equipment
- Factory automation
- Fire and security
- Smart Energy/Smart Grid solutions
- Intelligent lighting control
- Transportation

Figure 1-1. Stellaris LM4F Block Diagram

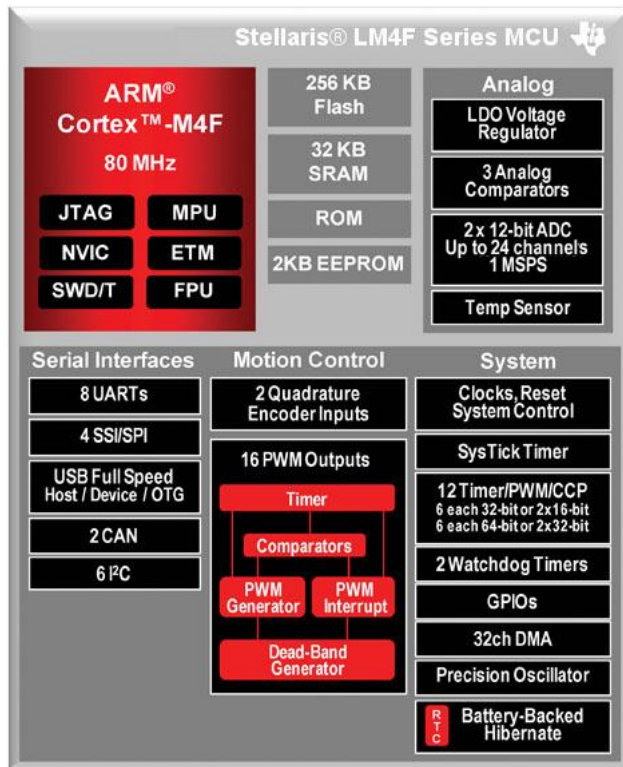

The Stellaris LM4F microcontrollers consist of fifteen pin-compatible series of devices, summarized below. Each series has a range of embedded Flash and SRAM sizes.

Table 1-1. Stellaris LM4F Device Series

General MCU (LM4F11x Series)	General MCU + USB Device (LM4F12x Series)	General MCU + USB OTG (LM4F13x Series)	Motion Control (LM4F21x Series)	Motion Control + USB OTG (LM4F23x Series)	Package
LM4F110	LM4F120	LM4F130	LM4F210	LM4F230	64-pin LQFP
LM4F111	LM4F121	LM4F131	LM4F211	LM4F231	64-pin LQFP
LM4F112	LM4F122	LM4F132	LM4F212	LM4F232	100-pin LQFP 144-pin LQFP 157-ball BGA (LM4F212 and LM4F232 only)

The Stellaris LM4F23x Series for MCU control applications with advanced motion control timers and USB OTG/ Host/Device offers advanced motion control timers and USB OTG/Host/Device capability with a generous number of serial peripherals in four packages.

Table 1-2. Stellaris LM4F23x Series

Part Number	Flash (KB)	SRAM (KB)	5-V Tolerant GPIOs	Package	Notes
LM4F230E5QR	128	32	43	64-pin LQFP	Includes low-power hibernate functionality.
LM4F230H5QR	256	32			
LM4F231E5QR	128	32	49	64-pin LQFP	No low-power hibernate functionality, but includes additional serial functionality, and up to six more I/Os than the LM4F230 Series.
LM4F231H5QR	256	32			
LM4F232E5QC	128	32	69	100-pin LQFP	Includes low-power hibernate functionality, and additional motion control, serial, and analog functionality in larger pin-count packages.
LM4F232H5QC	256	32			
LM4F232H5QD	256	32	105	144-pin LQFP	
LM4F232H5BB	256	32	120	157-ball BGA	

Table 1-3. Stellaris LM4F Family of Devices

Part Number	Flash (KB)	SRAM (KB)	Battery-Backed Hibernation	PWM	PWM Faults	QEI Channels	CAN MAC	USB ^a	UART	UART Modem Signalling	I ² C	SSI/SPI	ADC Channels	ADC External Reference	Analog/Digital Comparators	5-V Tolerant GPIOs ^b	Package
LM4F110B2QR	32	12	✓	-	-	-	1	-	8	-	4	4	12	-	2/16	0-43	64LQFP
LM4F110C4QR	64	24	✓	-	-	-	1	-	8	-	4	4	12	-	2/16	0-43	64LQFP
LM4F110E5QR	128	32	✓	-	-	-	1	-	8	-	4	4	12	-	2/16	0-43	64LQFP
LM4F110H5QR	256	32	✓	-	-	-	1	-	8	-	4	4	12	-	2/16	0-43	64LQFP
LM4F111B2QR	32	12	-	-	-	-	1	-	8	-	6	4	12	-	2/16	0-49	64LQFP
LM4F111C4QR	64	24	-	-	-	-	1	-	8	-	6	4	12	-	2/16	0-49	64LQFP
LM4F111E5QR	128	32	-	-	-	-	1	-	8	-	6	4	12	-	2/16	0-49	64LQFP
LM4F111H5QR	256	32	-	-	-	-	1	-	8	-	6	4	12	-	2/16	0-49	64LQFP
LM4F112C4QC	64	24	✓	-	-	-	1	-	8	✓	6	4	22	✓	3/16	0-69	100LQFP
LM4F112E5QC	128	32	✓	-	-	-	1	-	8	✓	6	4	22	✓	3/16	0-69	100LQFP
LM4F112H5QC	256	32	✓	-	-	-	1	-	8	✓	6	4	22	✓	3/16	0-69	100LQFP
LM4F112H5QD	256	32	✓	-	-	-	1	-	8	✓	6	4	24	✓	3/16	0-105	144LQFP
LM4F120B2QR	32	12	✓	-	-	-	1	D	8	-	4	4	12	-	2/16	0-43	64LQFP
LM4F120C4QR	64	24	✓	-	-	-	1	D	8	-	4	4	12	-	2/16	0-43	64LQFP
LM4F120E5QR	128	32	✓	-	-	-	1	D	8	-	4	4	12	-	2/16	0-43	64LQFP
LM4F120H5QR	256	32	✓	-	-	-	1	D	8	-	4	4	12	-	2/16	0-43	64LQFP
LM4F121B2QR	32	12	-	-	-	-	1	D	8	-	6	4	12	-	2/16	0-49	64LQFP
LM4F121C4QR	64	24	-	-	-	-	1	D	8	-	6	4	12	-	2/16	0-49	64LQFP
LM4F121E5QR	128	32	-	-	-	-	1	D	8	-	6	4	12	-	2/16	0-49	64LQFP
LM4F121H5QR	256	32	-	-	-	-	1	D	8	-	6	4	12	-	2/16	0-49	64LQFP
LM4F122C4QC	64	24	✓	-	-	-	1	D	8	✓	6	4	22	✓	3/16	0-69	100LQFP
LM4F122E5QC	128	32	✓	-	-	-	1	D	8	✓	6	4	22	✓	3/16	0-69	100LQFP
LM4F122H5QC	256	32	✓	-	-	-	1	D	8	✓	6	4	22	✓	3/16	0-69	100LQFP
LM4F122H5QD	256	32	✓	-	-	-	1	D	8	✓	6	4	24	✓	3/16	0-105	144LQFP

Table 1-3. Stellaris LM4F Family of Devices (continued)

Part Number	Flash (KB)	SRAM (KB)	Battery-Backed Hibernation	PWM	PWM Faults	QEI Channels	CAN MAC	USB ^a	UART	UART Modem Signalling	I ² C	SSI/SPI	ADC Channels	ADC External Reference	Analog/Digital Comparators	5-V Tolerant GPIOs ^b	Package
LM4F130C4QR	64	24	✓	–	–	–	1	O	8	–	4	4	12	–	2/16	0-43	64LQFP
LM4F130E5QR	128	32	✓	–	–	–	1	O	8	–	4	4	12	–	2/16	0-43	64LQFP
LM4F130H5QR	256	32	✓	–	–	–	1	O	8	–	4	4	12	–	2/16	0-43	64LQFP
LM4F131C4QR	64	24	–	–	–	–	1	O	8	–	6	4	12	–	2/16	0-49	64LQFP
LM4F131E5QR	128	32	–	–	–	–	1	O	8	–	6	4	12	–	2/16	0-49	64LQFP
LM4F131H5QR	256	32	–	–	–	–	1	O	8	–	6	4	12	–	2/16	0-49	64LQFP
LM4F132C4QC	64	24	✓	–	–	–	1	O	8	✓	6	4	22	✓	3/16	0-69	100LQFP
LM4F132E5QC	128	32	✓	–	–	–	1	O	8	✓	6	4	22	✓	3/16	0-69	100LQFP
LM4F132H5QC	256	32	✓	–	–	–	1	O	8	✓	6	4	22	✓	3/16	0-69	100LQFP
LM4F132H5QD	256	32	✓	–	–	–	1	O	8	✓	6	4	24	✓	3/16	0-105	144LQFP
LM4F210E5QR	128	32	✓	16	2	2	2	–	8	✓	4	4	12	–	2/16	0-43	64LQFP
LM4F210H5QR	256	32	✓	16	2	2	2	–	8	✓	4	4	12	–	2/16	0-43	64LQFP
LM4F211E5QR	128	32	–	16	6	2	2	–	8	✓	6	4	12	–	2/16	0-49	64LQFP
LM4F211H5QR	256	32	–	16	6	2	2	–	8	✓	6	4	12	–	2/16	0-49	64LQFP
LM4F212E5QC	128	32	✓	16	8	2	2	–	8	✓	6	4	22	✓	3/16	0-69	100LQFP
LM4F212H5BB	256	32	✓	16	8	2	2	–	8	✓	6	4	24	✓	3/16	0-120	157BGA
LM4F212H5QC	256	32	✓	16	8	2	2	–	8	✓	6	4	22	✓	3/16	0-69	100LQFP
LM4F212H5QD	256	32	✓	16	8	2	2	–	8	✓	6	4	24	✓	3/16	0-105	144LQFP
LM4F230E5QR	128	32	✓	16	2	2	2	O	8	–	4	4	12	–	2/16	0-43	64LQFP
LM4F230H5QR	256	32	✓	16	2	2	2	O	8	–	4	4	12	–	2/16	0-43	64LQFP
LM4F231E5QR	128	32	–	16	6	2	2	O	8	–	6	4	12	–	2/16	0-49	64LQFP
LM4F231H5QR	256	32	–	16	6	2	2	O	8	–	6	4	12	–	2/16	0-49	64LQFP
LM4F232E5QC	128	32	✓	16	8	2	2	O	8	✓	6	4	22	✓	3/16	0-69	100LQFP
LM4F232H5BB	256	32	✓	16	8	2	2	O	8	✓	6	4	24	✓	3/16	0-120	157BGA
LM4F232H5QC	256	32	✓	16	8	2	2	O	8	✓	6	4	22	✓	3/16	0-69	100LQFP
LM4F232H5QD	256	32	✓	16	8	2	2	O	8	✓	6	4	24	✓	3/16	0-105	144LQFP

a. USB options for Stellaris microcontrollers include Device Only (D) capability, Host/Device (H) capability, and On-The-Go/Host/Device capability (O).

b. Minimum is number of pins dedicated to GPIO; additional pins are available if certain peripherals are not used. See data sheet for details.

1.2 LM4F231H5QR Microcontroller Overview

The Stellaris LM4F231H5QR microcontroller combines complex integration and high performance with the features shown in Table 1-4.

Table 1-4. Stellaris LM4F231H5QR Microcontroller Features

Feature	Description
Core	ARM Cortex-M4F processor core
Performance	80-MHz operation; 100 DMIPS performance
Flash	256 KB single-cycle Flash memory

Table 1-4. Stellaris LM4F231H5QR Microcontroller Features (continued)

Feature	Description
System SRAM	32 KB single-cycle SRAM
EEPROM	2KB of EEPROM
Internal ROM	Internal ROM loaded with StellarisWare® software
Communication Interfaces	
Universal Asynchronous Receivers/Transmitter (UART)	Eight UARTs
Synchronous Serial Interface (SSI)	Four SSI modules
Inter-Integrated Circuit (I ² C)	Six I ² C modules with four transmission speeds including high-speed mode
Controller Area Network (CAN)	Two CAN 2.0 A/B controllers
Universal Serial Bus (USB)	USB 2.0 OTG/Host/Device
System Integration	
Micro Direct Memory Access (μDMA)	ARM® PrimeCell® 32-channel configurable μDMA controller
General-Purpose Timer (GPTM)	Six 16/32-bit GPTM blocks and six 32/64-bit Wide GPTM blocks
Watchdog Timer (WDT)	Two watchdog timers
General-Purpose Input/Output (GPIO)	Seven physical GPIO blocks
Advanced Motion Control	
Pulse Width Modulator (PWM)	Two PWM modules
Quadrature Encoder Interface (QEI)	Two QEI modules
Analog Support	
Analog-to-Digital Converter (ADC)	Two 12-bit ADC modules
Analog Comparator Controller	Two independent integrated analog comparators
Digital Comparator	16 digital comparators
JTAG and Serial Wire Debug (SWD)	One JTAG module with integrated ARM SWD
Package	64-pin LQFP
Operating Range	Industrial (-40°C to 85°C) temperature range

Figure 1-2 on page 50 shows the features on the Stellaris LM4F231H5QR microcontroller. Note that there are two on-chip buses that connect the core to the peripherals. The Advanced Peripheral Bus (APB) bus is the legacy bus. The Advanced High-Performance Bus (AHB) bus provides better back-to-back access performance than the APB bus.

Figure 1-2. Stellaris LM4F231H5QR Microcontroller High-Level Block Diagram

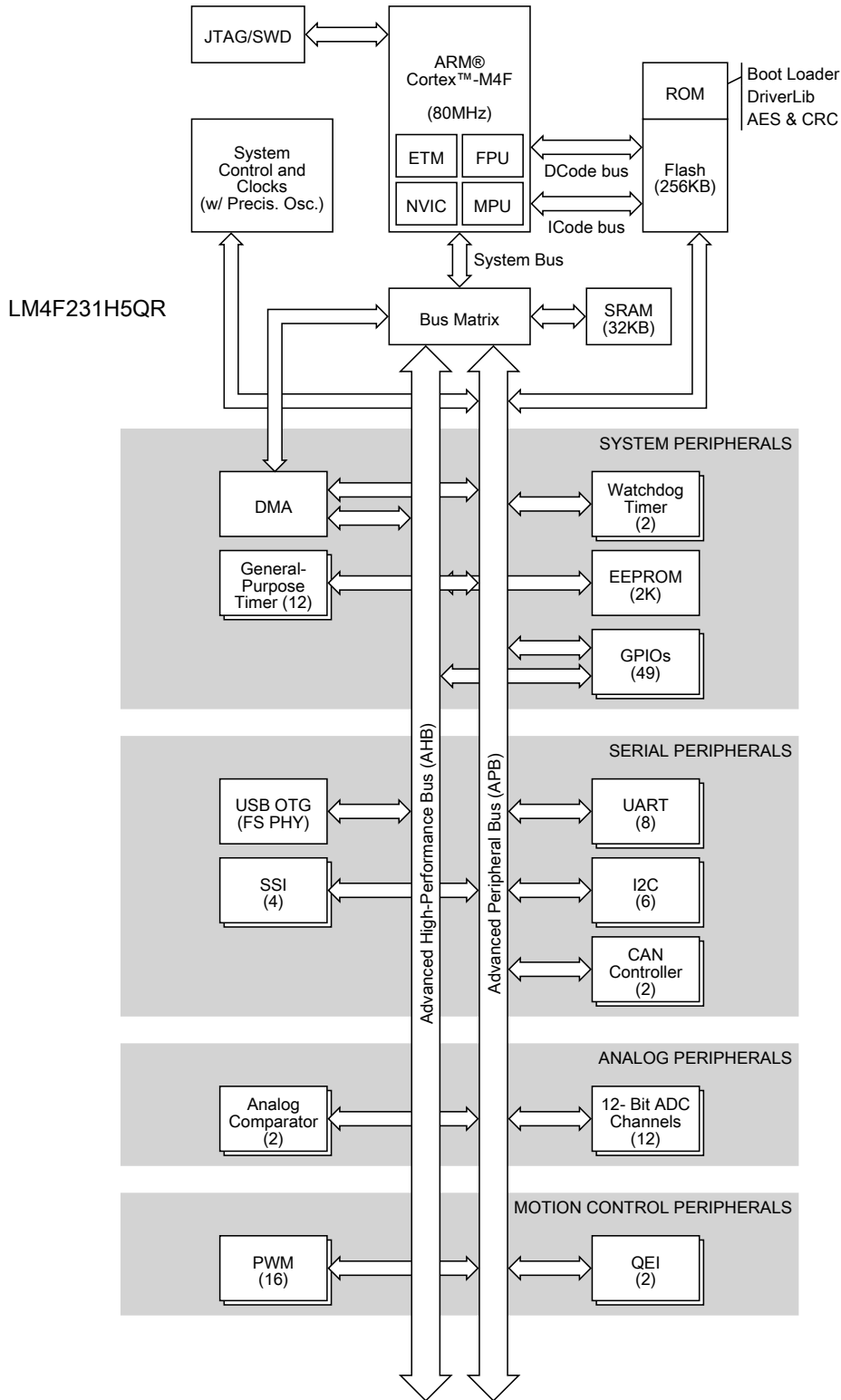

In addition, the LM4F231H5QR microcontroller offers the advantages of ARM's widely available development tools, System-on-Chip (SoC) infrastructure IP applications, and a large user community. Additionally, the microcontroller uses ARM's Thumb®-compatible Thumb-2 instruction set to reduce memory requirements and, thereby, cost. Finally, the LM4F231H5QR microcontroller is code-compatible to all members of the extensive Stellaris family; providing flexibility to fit precise needs.

Texas Instruments offers a complete solution to get to market quickly, with evaluation and development boards, white papers and application notes, an easy-to-use peripheral driver library, and a strong support, sales, and distributor network.

1.3 LM4F231H5QR Microcontroller Features

The LM4F231H5QR microcontroller component features and general function are discussed in more detail in the following section.

1.3.1 ARM Cortex-M4F Processor Core

All members of the Stellaris product family, including the LM4F231H5QR microcontroller, are designed around an ARM Cortex-M processor core. The ARM Cortex-M processor provides the core for a high-performance, low-cost platform that meets the needs of minimal memory implementation, reduced pin count, and low power consumption, while delivering outstanding computational performance and exceptional system response to interrupts.

1.3.1.1 Processor Core (see page 70)

- 32-bit ARM Cortex-M4F architecture optimized for small-footprint embedded applications
- 80-MHz operation; 100 DMIPS performance
- Outstanding processing performance combined with fast interrupt handling
- Thumb-2 mixed 16-/32-bit instruction set delivers the high performance expected of a 32-bit ARM core in a compact memory size usually associated with 8- and 16-bit devices, typically in the range of a few kilobytes of memory for microcontroller-class applications
 - Single-cycle multiply instruction and hardware divide
 - Atomic bit manipulation (bit-banding), delivering maximum memory utilization and streamlined peripheral control
 - Unaligned data access, enabling data to be efficiently packed into memory
- IEEE754-compliant single-precision Floating-Point Unit (FPU)
- 16-bit SIMD vector processing unit
- Fast code execution permits slower processor clock or increases sleep mode time
- Harvard architecture characterized by separate buses for instruction and data
- Efficient processor core, system and memories
- Hardware division and fast digital-signal-processing orientated multiply accumulate
- Saturating arithmetic for signal processing

- Deterministic, high-performance interrupt handling for time-critical applications
- Memory protection unit (MPU) to provide a privileged mode for protected operating system functionality
- Enhanced system debug with extensive breakpoint and trace capabilities
- Serial Wire Debug and Serial Wire Trace reduce the number of pins required for debugging and tracing
- Migration from the ARM7 processor family for better performance and power efficiency
- Optimized for single-cycle Flash memory usage
- Ultra-low power consumption with integrated sleep modes

1.3.1.2 System Timer (SysTick) (see page 124)

ARM Cortex-M4F includes an integrated system timer, SysTick. SysTick provides a simple, 24-bit, clear-on-write, decrementing, wrap-on-zero counter with a flexible control mechanism. The counter can be used in several different ways, for example:

- An RTOS tick timer that fires at a programmable rate (for example, 100 Hz) and invokes a SysTick routine
- A high-speed alarm timer using the system clock
- A variable rate alarm or signal timer—the duration is range-dependent on the reference clock used and the dynamic range of the counter
- A simple counter used to measure time to completion and time used
- An internal clock-source control based on missing/meeting durations.

1.3.1.3 Nested Vectored Interrupt Controller (NVIC) (see page 125)

The LM4F231H5QR controller includes the ARM Nested Vectored Interrupt Controller (NVIC). The NVIC and Cortex-M4F prioritize and handle all exceptions in Handler Mode. The processor state is automatically stored to the stack on an exception and automatically restored from the stack at the end of the Interrupt Service Routine (ISR). The interrupt vector is fetched in parallel to the state saving, enabling efficient interrupt entry. The processor supports tail-chaining, meaning that back-to-back interrupts can be performed without the overhead of state saving and restoration. Software can set eight priority levels on 7 exceptions (system handlers) and 80 interrupts.

- Deterministic, fast interrupt processing: always 12 cycles, or just 6 cycles with tail-chaining
- External non-maskable interrupt signal (NMI) available for immediate execution of NMI handler for safety critical applications
- Dynamically reprioritizable interrupts
- Exceptional interrupt handling via hardware implementation of required register manipulations

1.3.1.4 System Control Block (SCB) (see page 126)

The SCB provides system implementation information and system control, including configuration, control, and reporting of system exceptions.

1.3.1.5 Memory Protection Unit (MPU) (see page 126)

The MPU supports the standard ARM7 Protected Memory System Architecture (PMSA) model. The MPU provides full support for protection regions, overlapping protection regions, access permissions, and exporting memory attributes to the system.

1.3.1.6 Floating-Point Unit (FPU) (see page 131)

The FPU fully supports single-precision add, subtract, multiply, divide, multiply and accumulate, and square root operations. It also provides conversions between fixed-point and floating-point data formats, and floating-point constant instructions.

- 32-bit instructions for single-precision (C float) data-processing operations
- Combined Multiply and Accumulate instructions for increased precision (Fused MAC)
- Hardware support for conversion, addition, subtraction, multiplication with optional accumulate, division, and square-root
- Hardware support for denormals and all IEEE rounding modes
- 32 dedicated 32-bit single-precision registers, also addressable as 16 double-word registers
- Decoupled three stage pipeline

1.3.2 On-Chip Memory

The LM4F231H5QR microcontroller is integrated with the following set of on-chip memory and features:

- 32 KB single-cycle SRAM
- 256 KB single-cycle Flash memory
- Internal ROM loaded with StellarisWare software:
 - Stellaris Peripheral Driver Library
 - Stellaris Boot Loader
 - Advanced Encryption Standard (AES) cryptography tables
 - Cyclic Redundancy Check (CRC) error detection functionality
- 2KB EEPROM

1.3.2.1 SRAM (see page 502)

The LM4F231H5QR microcontroller provides 32 KB of single-cycle on-chip SRAM. The internal SRAM of the Stellaris devices is located at offset 0x2000.0000 of the device memory map.

Because read-modify-write (RMW) operations are very time consuming, ARM has introduced *bit-banding* technology in the Cortex-M4F processor. With a bit-band-enabled processor, certain regions in the memory map (SRAM and peripheral space) can use address aliases to access individual bits in a single, atomic operation.

Data can be transferred to and from the SRAM using the Micro Direct Memory Access Controller (μ DMA).

1.3.2.2 Flash Memory (see page 505)

The LM4F231H5QR microcontroller provides 256 KB of single-cycle on-chip Flash memory. The Flash memory is organized as a set of 1-KB blocks that can be individually erased. Erasing a block causes the entire contents of the block to be reset to all 1s. These blocks are paired into a set of 2-KB blocks that can be individually protected. The blocks can be marked as read-only or execute-only, providing different levels of code protection. Read-only blocks cannot be erased or programmed, protecting the contents of those blocks from being modified. Execute-only blocks cannot be erased or programmed, and can only be read by the controller instruction fetch mechanism, protecting the contents of those blocks from being read by either the controller or by a debugger.

1.3.2.3 ROM (see page 503)

The LM4F231H5QR ROM is preprogrammed with the following software and programs:

- Stellaris Peripheral Driver Library
- Stellaris Boot Loader
- Advanced Encryption Standard (AES) cryptography tables
- Cyclic Redundancy Check (CRC) error-detection functionality

The Stellaris Peripheral Driver Library is a royalty-free software library for controlling on-chip peripherals with a boot-loader capability. The library performs both peripheral initialization and control functions, with a choice of polled or interrupt-driven peripheral support. In addition, the library is designed to take full advantage of the stellar interrupt performance of the ARM Cortex-M4F core. No special pragmas or custom assembly code prologue/epilogue functions are required. For applications that require in-field programmability, the royalty-free Stellaris Boot Loader can act as an application loader and support in-field firmware updates.

The Advanced Encryption Standard (AES) is a publicly defined encryption standard used by the U.S. Government. AES is a strong encryption method with reasonable performance and size. In addition, it is fast in both hardware and software, is fairly easy to implement, and requires little memory. The Texas Instruments encryption package is available with full source code, and is based on lesser general public license (LGPL) source. An LGPL means that the code can be used within an application without any copyleft implications for the application (the code does not automatically become open source). Modifications to the package source, however, must be open source.

CRC (Cyclic Redundancy Check) is a technique to validate a span of data has the same contents as when previously checked. This technique can be used to validate correct receipt of messages (nothing lost or modified in transit), to validate data after decompression, to validate that Flash memory contents have not been changed, and for other cases where the data needs to be validated. A CRC is preferred over a simple checksum (e.g. XOR all bits) because it catches changes more readily.

1.3.2.4 EEPROM (see page 509)

The LM4F231H5QR microcontroller includes an EEPROM with the following features:

- 2K bytes of memory accessible as 512 32-bit words
- 32 blocks of 16 words (64 bytes) each
- Built-in wear leveling

- Access protection per block
- Lock protection option for the whole peripheral as well as per block using 32-bit to 96-bit unlock codes (application selectable)
- Interrupt support for write completion to avoid polling
- Endurance of 500K writes (when writing at fixed offset in every alternate page in circular fashion) to 15M operations (when cycling through two pages) per each 2-page block.

1.3.3 Serial Communications Peripherals

The LM4F231H5QR controller supports both asynchronous and synchronous serial communications with:

- Two CAN 2.0 A/B controllers
- USB 2.0 OTG/Host/Device
- Eight UARTs with IrDA, 9-bit and ISO 7816 support (one UART with modem flow control)
- Six I²C modules with four transmission speeds including high-speed mode
- Four Synchronous Serial Interface modules (SSI)

The following sections provide more detail on each of these communications functions.

1.3.3.1 Controller Area Network (see page 1008)

Controller Area Network (CAN) is a multicast shared serial-bus standard for connecting electronic control units (ECUs). CAN was specifically designed to be robust in electromagnetically noisy environments and can utilize a differential balanced line like RS-485 or twisted-pair wire. Originally created for automotive purposes, it is now used in many embedded control applications (for example, industrial or medical). Bit rates up to 1 Mbps are possible at network lengths below 40 meters. Decreased bit rates allow longer network distances (for example, 125 Kbps at 500m).

A transmitter sends a message to all CAN nodes (broadcasting). Each node decides on the basis of the identifier received whether it should process the message. The identifier also determines the priority that the message enjoys in competition for bus access. Each CAN message can transmit from 0 to 8 bytes of user information.

The LM4F231H5QR microcontroller includes two CAN units with the following features:

- CAN protocol version 2.0 part A/B
- Bit rates up to 1 Mbps
- 32 message objects with individual identifier masks
- Maskable interrupt
- Disable Automatic Retransmission mode for Time-Triggered CAN (TTCAN) applications
- Programmable Loopback mode for self-test operation
- Programmable FIFO mode enables storage of multiple message objects

- Gluelessly attaches to an external CAN transceiver through the CANnTX and CANnRX signals

1.3.3.2 USB (see page 1059)

Universal Serial Bus (USB) is a serial bus standard designed to allow peripherals to be connected and disconnected using a standardized interface without rebooting the system.

The LM4F231H5QR microcontroller supports three configurations in USB 2.0 full and low speed: USB Device, USB Host, and USB On-The-Go (negotiated on-the-go as host or device when connected to other USB-enabled systems).

The USB module has the following features:

- Complies with USB-IF certification standards
- USB 2.0 full-speed (12 Mbps) and low-speed (1.5 Mbps) operation with integrated PHY
- 4 transfer types: Control, Interrupt, Bulk, and Isochronous
- 16 endpoints
 - 1 dedicated control IN endpoint and 1 dedicated control OUT endpoint
 - 7 configurable IN endpoints and 7 configurable OUT endpoints
- 4 KB dedicated endpoint memory: one endpoint may be defined for double-buffered 1023-byte isochronous packet size
- VBUS droop and valid ID detection and interrupt
- Efficient transfers using Micro Direct Memory Access Controller (μ DMA)
 - Separate channels for transmit and receive for up to three IN endpoints and three OUT endpoints
 - Channel requests asserted when FIFO contains required amount of data

1.3.3.3 UART (see page 855)

A Universal Asynchronous Receiver/Transmitter (UART) is an integrated circuit used for RS-232C serial communications, containing a transmitter (parallel-to-serial converter) and a receiver (serial-to-parallel converter), each clocked separately.

The LM4F231H5QR microcontroller includes eight fully programmable 16C550-type UARTs. Although the functionality is similar to a 16C550 UART, this UART design is not register compatible. The UART can generate individually masked interrupts from the Rx, Tx, modem flow control, and error conditions. The module generates a single combined interrupt when any of the interrupts are asserted and are unmasked.

The eight UARTs have the following features:

- Programmable baud-rate generator allowing speeds up to 5 Mbps for regular speed (divide by 16) and 10 Mbps for high speed (divide by 8)
- Separate 16x8 transmit (TX) and receive (RX) FIFOs to reduce CPU interrupt service loading
- Programmable FIFO length, including 1-byte deep operation providing conventional double-buffered interface

- FIFO trigger levels of 1/8, 1/4, 1/2, 3/4, and 7/8
- Standard asynchronous communication bits for start, stop, and parity
- Line-break generation and detection
- Fully programmable serial interface characteristics
 - 5, 6, 7, or 8 data bits
 - Even, odd, stick, or no-parity bit generation/detection
 - 1 or 2 stop bit generation
- IrDA serial-IR (SIR) encoder/decoder providing
 - Programmable use of IrDA Serial Infrared (SIR) or UART input/output
 - Support of IrDA SIR encoder/decoder functions for data rates up to 115.2 Kbps half-duplex
 - Support of normal 3/16 and low-power (1.41-2.23 μ s) bit durations
 - Programmable internal clock generator enabling division of reference clock by 1 to 256 for low-power mode bit duration
- Support for communication with ISO 7816 smart cards
- Modem flow control (on UART1)
- LIN protocol support
- EIA-485 9-bit support
- Standard FIFO-level and End-of-Transmission interrupts
- Efficient transfers using Micro Direct Memory Access Controller (μ DMA)
 - Separate channels for transmit and receive
 - Receive single request asserted when data is in the FIFO; burst request asserted at programmed FIFO level
 - Transmit single request asserted when there is space in the FIFO; burst request asserted at programmed FIFO level

1.3.3.4 I²C (see page 961)

The Inter-Integrated Circuit (I²C) bus provides bi-directional data transfer through a two-wire design (a serial data line SDA and a serial clock line SCL). The I²C bus interfaces to external I²C devices such as serial memory (RAMs and ROMs), networking devices, LCDs, tone generators, and so on. The I²C bus may also be used for system testing and diagnostic purposes in product development and manufacture.

Each device on the I²C bus can be designated as either a master or a slave. I²C module supports both sending and receiving data as either a master or a slave and can operate simultaneously as both a master and a slave. Both the I²C master and slave can generate interrupts.

The LM4F231H5QR microcontroller includes six I²C modules with the following features:

- Devices on the I²C bus can be designated as either a master or a slave
 - Supports both transmitting and receiving data as either a master or a slave
 - Supports simultaneous master and slave operation
- Four I²C modes
 - Master transmit
 - Master receive
 - Slave transmit
 - Slave receive
- Four transmission speeds:
 - Standard (100 Kbps)
 - Fast-mode (400 Kbps)
 - Fast-mode plus (1 Mbps)
 - High-speed mode (3.33 Mbps)
- Clock low timeout interrupt
- Dual slave address capability
- Clock low timeout interrupt
- Dual slave address capability
- Master and slave interrupt generation
 - Master generates interrupts when a transmit or receive operation completes (or aborts due to an error)
 - Slave generates interrupts when data has been transferred or requested by a master or when a START or STOP condition is detected
- Master with arbitration and clock synchronization, multimaster support, and 7-bit addressing mode

1.3.3.5 SSI (see page 918)

Synchronous Serial Interface (SSI) is a four-wire bi-directional communications interface that converts data between parallel and serial. The SSI module performs serial-to-parallel conversion on data received from a peripheral device, and parallel-to-serial conversion on data transmitted to a peripheral device. The SSI module can be configured as either a master or slave device. As a slave device, the SSI module can also be configured to disable its output, which allows a master device to be coupled with multiple slave devices. The TX and RX paths are buffered with separate internal FIFOs.

The SSI module also includes a programmable bit rate clock divider and prescaler to generate the output serial clock derived from the SSI module's input clock. Bit rates are generated based on the input clock and the maximum bit rate is determined by the connected peripheral.

The LM4F231H5QR microcontroller includes four SSI modules with the following features:

- Programmable interface operation for Freescale SPI, MICROWIRE, or Texas Instruments synchronous serial interfaces
- Master or slave operation
- Programmable clock bit rate and prescaler
- Separate transmit and receive FIFOs, each 16 bits wide and 8 locations deep
- Programmable data frame size from 4 to 16 bits
- Internal loopback test mode for diagnostic/debug testing
- Standard FIFO-based interrupts and End-of-Transmission interrupt
- Efficient transfers using Micro Direct Memory Access Controller (μ DMA)
 - Separate channels for transmit and receive
 - Receive single request asserted when data is in the FIFO; burst request asserted when FIFO contains 4 entries
 - Transmit single request asserted when there is space in the FIFO; burst request asserted when FIFO contains 4 entries

1.3.4 System Integration

The LM4F231H5QR microcontroller provides a variety of standard system functions integrated into the device, including:

- Direct Memory Access Controller (DMA)
- System control and clocks including on-chip precision 16-MHz oscillator
- Six 32-bit timers (up to twelve 16-bit), with real-time clock capability
- Six wide 64-bit timers (up to twelve 32-bit), with real-time clock capability
- Twelve 16/32-bit Capture Compare PWM (CCP) pins
- Twelve 32/64-bit Capture Compare PWM (CCP) pins
- Two Watchdog Timers
 - One timer runs off the main oscillator
 - One timer runs off the precision internal oscillator
- Up to 49 GPIOs, depending on configuration
 - Highly flexible pin muxing allows use as GPIO or one of several peripheral functions
 - Independently configurable to 2, 4 or 8 mA drive capability
 - Up to 4 GPIOs can have 18 mA drive capability

The following sections provide more detail on each of these functions.

1.3.4.1 Direct Memory Access (see page 559)

The LM4F231H5QR microcontroller includes a Direct Memory Access (DMA) controller, known as micro-DMA (μ DMA). The μ DMA controller provides a way to offload data transfer tasks from the Cortex-M4F processor, allowing for more efficient use of the processor and the available bus bandwidth. The μ DMA controller can perform transfers between memory and peripherals. It has dedicated channels for each supported on-chip module and can be programmed to automatically perform transfers between peripherals and memory as the peripheral is ready to transfer more data. The μ DMA controller provides the following features:

- ARM PrimeCell[®] 32-channel configurable μ DMA controller
- Support for memory-to-memory, memory-to-peripheral, and peripheral-to-memory in multiple transfer modes
 - Basic for simple transfer scenarios
 - Ping-pong for continuous data flow
 - Scatter-gather for a programmable list of arbitrary transfers initiated from a single request
- Highly flexible and configurable channel operation
 - Independently configured and operated channels
 - Dedicated channels for supported on-chip modules
 - Flexible channel assignments
 - One channel each for receive and transmit path for bidirectional modules
 - Dedicated channel for software-initiated transfers
 - Per-channel configurable priority scheme
 - Optional software-initiated requests for any channel
- Two levels of priority
- Design optimizations for improved bus access performance between μ DMA controller and the processor core
 - μ DMA controller access is subordinate to core access
 - RAM striping
 - Peripheral bus segmentation
- Data sizes of 8, 16, and 32 bits
- Transfer size is programmable in binary steps from 1 to 1024
- Source and destination address increment size of byte, half-word, word, or no increment

- Maskable peripheral requests
- Interrupt on transfer completion, with a separate interrupt per channel

1.3.4.2 System Control and Clocks (see page 213)

System control determines the overall operation of the device. It provides information about the device, controls power-saving features, controls the clocking of the device and individual peripherals, and handles reset detection and reporting.

- Device identification information: version, part number, SRAM size, Flash memory size, and so on
- Power control
 - On-chip fixed Low Drop-Out (LDO) voltage regulator
 - Low-power options for microcontroller: Sleep and Deep-sleep modes with clock gating
 - Low-power options for on-chip modules: software controls shutdown of individual peripherals and memory
 - 3.3-V supply brown-out detection and reporting via interrupt or reset
- Multiple clock sources for microcontroller system clock
 - Precision Oscillator (PIOSC): On-chip resource providing a 16 MHz $\pm 1\%$ frequency at room temperature
 - 16 MHz $\pm 3\%$ across temperature
 - Software power down control for low power modes
 - Main Oscillator (MOSC): A frequency-accurate clock source by one of two means: an external single-ended clock source is connected to the OSC0 input pin, or an external crystal is connected across the OSC0 input and OSC1 output pins.
 - External crystal used with or without on-chip PLL: select supported frequencies from 4 MHz to 25 MHz.
 - External oscillator: from DC to maximum device speed
 - Internal 30-kHz Oscillator: on chip resource providing a 30 kHz $\pm 50\%$ frequency, used during power-saving modes
- Flexible reset sources
 - Power-on reset (POR)
 - Reset pin assertion
 - Brown-out reset (BOR) detector alerts to system power drops
 - Software reset
 - Watchdog timer reset
 - MOSC failure

1.3.4.3 Programmable Timers (see page 677)

Programmable timers can be used to count or time external events that drive the Timer input pins. Each 16/32-bit GPTM block provides two 16-bit timers/counters that can be configured to operate independently as timers or event counters, or configured to operate as one 32-bit timer or one 32-bit Real-Time Clock (RTC). Each 32/64-bit Wide GPTM block provides two 32-bit timers/counters that can be configured to operate independently as timers or event counters, or configured to operate as one 64-bit timer or one 64-bit Real-Time Clock (RTC). Timers can also be used to trigger analog-to-digital (ADC) conversions.

The General-Purpose Timer Module (GPTM) contains six 16/32-bit GPTM blocks and six 32/64-bit Wide GPTM blocks with the following functional options:

- 16/32-bit operating modes:
 - 16- or 32-bit programmable one-shot timer
 - 16- or 32-bit programmable periodic timer
 - 16-bit general-purpose timer with an 8-bit prescaler
 - 32-bit Real-Time Clock (RTC) when using an external 32.768-KHz clock as the input
 - 16-bit input-edge count- or time-capture modes with an 8-bit prescaler
 - 16-bit PWM mode with an 8-bit prescaler and software-programmable output inversion of the PWM signal
- 32/64-bit operating modes:
 - 32- or 64-bit programmable one-shot timer
 - 32- or 64-bit programmable periodic timer
 - 32-bit general-purpose timer with a 16-bit prescaler
 - 64-bit Real-Time Clock (RTC) when using an external 32.768-KHz clock as the input
 - 32-bit input-edge count- or time-capture modes with a 16-bit prescaler
 - 32-bit PWM mode with a 16-bit prescaler and software-programmable output inversion of the PWM signal
- Count up or down
- Twelve 16/32-bit Capture Compare PWM pins (CCP)
- Twelve 32/64-bit Capture Compare PWM pins (CCP)
- Daisy chaining of timer modules to allow a single timer to initiate multiple timing events
- Timer synchronization allows selected timers to start counting on the same clock cycle
- ADC event trigger
- User-enabled stalling when the microcontroller asserts CPU Halt flag during debug (excluding RTC mode)

- Ability to determine the elapsed time between the assertion of the timer interrupt and entry into the interrupt service routine.
- Efficient transfers using Micro Direct Memory Access Controller (μDMA)
 - Dedicated channel for each timer
 - Burst request generated on timer interrupt

1.3.4.4 CCP Pins (see page 685)

Capture Compare PWM pins (CCP) can be used by the General-Purpose Timer Module to time/count external events using the CCP pin as an input. Alternatively, the GPTM can generate a simple PWM output on the CCP pin.

The LM4F231H5QR microcontroller includes twelve 16/32-bit CCP pins that can be programmed to operate in the following modes:

- Capture: The GP Timer is incremented/decremented by programmed events on the CCP input. The GP Timer captures and stores the current timer value when a programmed event occurs.
- Compare: The GP Timer is incremented/decremented by programmed events on the CCP input. The GP Timer compares the current value with a stored value and generates an interrupt when a match occurs.
- PWM: The GP Timer is incremented/decremented by the system clock. A PWM signal is generated based on a match between the counter value and a value stored in a match register and is output on the CCP pin.

1.3.4.5 Watchdog Timers (see page 747)

A watchdog timer is used to regain control when a system has failed due to a software error or to the failure of an external device to respond in the expected way. The Stellaris Watchdog Timer can generate an interrupt, a non-maskable interrupt, or a reset when a time-out value is reached. In addition, the Watchdog Timer is ARM FiRM-compliant and can be configured to generate an interrupt to the microcontroller on its first time-out, and to generate a reset signal on its second time-out. Once the Watchdog Timer has been configured, the lock register can be written to prevent the timer configuration from being inadvertently altered.

The LM4F231H5QR microcontroller has two Watchdog Timer modules: Watchdog Timer 0 uses the system clock for its timer clock; Watchdog Timer 1 uses the PIOSC as its timer clock. The Stellaris Watchdog Timer module has the following features:

- 32-bit down counter with a programmable load register
- Separate watchdog clock with an enable
- Programmable interrupt generation logic with interrupt masking and optional NMI function
- Lock register protection from runaway software
- Reset generation logic with an enable/disable
- User-enabled stalling when the microcontroller asserts the CPU Halt flag during debug

1.3.4.6 Programmable GPIOs (see page 623)

General-purpose input/output (GPIO) pins offer flexibility for a variety of connections. The Stellaris GPIO module is comprised of seven physical GPIO blocks, each corresponding to an individual GPIO port. The GPIO module is FIRM-compliant (compliant to the ARM Foundation IP for Real-Time Microcontrollers specification) and supports 0-49 programmable input/output pins. The number of GPIOs available depends on the peripherals being used (see “Signal Tables” on page 1291 for the signals available to each GPIO pin).

- Up to 49 GPIOs, depending on configuration
- Highly flexible pin muxing allows use as GPIO or one of several peripheral functions
- 5-V-tolerant in input configuration
- Two means of port access: either Advanced High-Performance Bus (AHB) with better back-to-back access performance, or the legacy Advanced Peripheral Bus (APB) for backwards-compatibility with existing code for Ports A-G
- Fast toggle capable of a change every clock cycle for ports on AHB, every two clock cycles for ports on APB
- Programmable control for GPIO interrupts
 - Interrupt generation masking
 - Edge-triggered on rising, falling, or both
 - Level-sensitive on High or Low values
- Bit masking in both read and write operations through address lines
- Can be used to initiate an ADC sample sequence or a μ DMA transfer
- Pins configured as digital inputs are Schmitt-triggered
- Programmable control for GPIO pad configuration
 - Weak pull-up or pull-down resistors
 - 2-mA, 4-mA, and 8-mA pad drive for digital communication; up to four pads can sink 18-mA for high-current applications
 - Slew rate control for 8-mA pad drive
 - Open drain enables
 - Digital input enables

1.3.5 Advanced Motion Control

The LM4F231H5QR microcontroller provides motion control functions integrated into the device, including:

- Two PWM modules, with a total of 16 advanced PWM outputs for motion and energy applications
- Six fault inputs to promote low-latency shutdown

- Two Quadrature Encoder Inputs (QEI)

The following provides more detail on these motion control functions.

1.3.5.1 PWM (see page 1189)

Pulse width modulation (PWM) is a powerful technique for digitally encoding analog signal levels. High-resolution counters are used to generate a square wave, and the duty cycle of the square wave is modulated to encode an analog signal. Typical applications include switching power supplies and motor control. Each LM4F231H5QR PWM module consists of four PWM generator block and a control block. Each PWM generator block contains one timer (16-bit down or up/down counter), two comparators, a PWM signal generator, a dead-band generator, and an interrupt/ADC-trigger selector. Each PWM generator block produces two PWM signals that can either be independent signals or a single pair of complementary signals with dead-band delays inserted.

Each PWM generator has the following features:

- Three fault-condition handling inputs to quickly provide low-latency shutdown and prevent damage to the motor being controlled, for a total of six inputs
- One 16-bit counter
 - Runs in Down or Up/Down mode
 - Output frequency controlled by a 16-bit load value
 - Load value updates can be synchronized
 - Produces output signals at zero and load value
- Two PWM comparators
 - Comparator value updates can be synchronized
 - Produces output signals on match
- PWM signal generator
 - Output PWM signal is constructed based on actions taken as a result of the counter and PWM comparator output signals
 - Produces two independent PWM signals
- Dead-band generator
 - Produces two PWM signals with programmable dead-band delays suitable for driving a half-H bridge
 - Can be bypassed, leaving input PWM signals unmodified
- Can initiate an ADC sample sequence

The control block determines the polarity of the PWM signals and which signals are passed through to the pins. The output of the PWM generation blocks are managed by the output control block before being passed to the device pins. The PWM control block has the following options:

- PWM output enable of each PWM signal

- Optional output inversion of each PWM signal (polarity control)
- Optional fault handling for each PWM signal
- Synchronization of timers in the PWM generator blocks
- Synchronization of timer/comparator updates across the PWM generator blocks
- Extended PWM synchronization of timer/comparator updates across the PWM generator blocks
- Interrupt status summary of the PWM generator blocks
- Extended PWM fault handling, with multiple fault signals, programmable polarities, and filtering
- PWM generators can be operated independently or synchronized with other generators

1.3.5.2 QEI (see page 1268)

A quadrature encoder, also known as a 2-channel incremental encoder, converts linear displacement into a pulse signal. By monitoring both the number of pulses and the relative phase of the two signals, the position, direction of rotation, and speed can be tracked. In addition, a third channel, or index signal, can be used to reset the position counter. The Stellaris quadrature encoder with index (QEI) module interprets the code produced by a quadrature encoder wheel to integrate position over time and determine direction of rotation. In addition, it can capture a running estimate of the velocity of the encoder wheel. The input frequency of the QEI inputs may be as high as 1/4 of the processor frequency (for example, 20 MHz for a 80-MHz system).

The LM4F231H5QR microcontroller includes two QEI modules providing control of two motors at the same time with the following features:

- Position integrator that tracks the encoder position
- Programmable noise filter on the inputs
- Velocity capture using built-in timer
- The input frequency of the QEI inputs may be as high as 1/4 of the processor frequency (for example, 12.5 MHz for a 50-MHz system)
- Interrupt generation on:
 - Index pulse
 - Velocity-timer expiration
 - Direction change
 - Quadrature error detection

1.3.6 Analog

The LM4F231H5QR microcontroller provides analog functions integrated into the device, including:

- Two 12-bit Analog-to-Digital Converters (ADC) with 12 analog input channels and a sample rate of one million samples/second
- Two analog comparators

- 16 digital comparators
- On-chip voltage regulator

The following provides more detail on these analog functions.

1.3.6.1 ADC (see page 772)

An analog-to-digital converter (ADC) is a peripheral that converts a continuous analog voltage to a discrete digital number. The Stellaris ADC module features 12-bit conversion resolution and supports 12 input channels plus an internal temperature sensor. Four buffered sample sequencers allow rapid sampling of up to 12 analog input sources without controller intervention. Each sample sequencer provides flexible programming with fully configurable input source, trigger events, interrupt generation, and sequencer priority. Each ADC module has a digital comparator function that allows the conversion value to be diverted to a comparison unit that provides eight digital comparators.

The LM4F231H5QR microcontroller provides two ADC modules with the following features:

- 12 shared analog input channels
- 12-bit precision ADC
- Single-ended and differential-input configurations
- On-chip internal temperature sensor
- Maximum sample rate of one million samples/second
- Optional phase shift in sample time programmable from 22.5° to 337.5°
- Four programmable sample conversion sequencers from one to eight entries long, with corresponding conversion result FIFOs
- Flexible trigger control
 - Controller (software)
 - Timers
 - Analog Comparators
 - PWM
 - GPIO
- Hardware averaging of up to 64 samples
- Digital comparison unit providing eight digital comparators
- Converter uses VDDA and GNDA as the voltage reference
- Power and ground for the analog circuitry is separate from the digital power and ground
- Efficient transfers using Micro Direct Memory Access Controller (μDMA)
 - Dedicated channel for each sample sequencer

- ADC module uses burst requests for DMA

1.3.6.2 Analog Comparators (see page 1174)

An analog comparator is a peripheral that compares two analog voltages and provides a logical output that signals the comparison result. The LM4F231H5QR microcontroller provides two independent integrated analog comparators that can be configured to drive an output or generate an interrupt or ADC event.

The comparator can provide its output to a device pin, acting as a replacement for an analog comparator on the board, or it can be used to signal the application via interrupts or triggers to the ADC to cause it to start capturing a sample sequence. The interrupt generation and ADC triggering logic is separate. This means, for example, that an interrupt can be generated on a rising edge and the ADC triggered on a falling edge.

The LM4F231H5QR microcontroller provides two independent integrated analog comparators with the following functions:

- Compare external pin input to external pin input or to internal programmable voltage reference
- Compare a test voltage against any one of the following voltages:
 - An individual external reference voltage
 - A shared single external reference voltage
 - A shared internal reference voltage

1.3.7 JTAG and ARM Serial Wire Debug (see page 201)

The Joint Test Action Group (JTAG) port is an IEEE standard that defines a Test Access Port and Boundary Scan Architecture for digital integrated circuits and provides a standardized serial interface for controlling the associated test logic. The TAP, Instruction Register (IR), and Data Registers (DR) can be used to test the interconnections of assembled printed circuit boards and obtain manufacturing information on the components. The JTAG Port also provides a means of accessing and controlling design-for-test features such as I/O pin observation and control, scan testing, and debugging. Texas Instruments replaces the ARM SW-DP and JTAG-DP with the ARM Serial Wire JTAG Debug Port (SWJ-DP) interface. The SWJ-DP interface combines the SWD and JTAG debug ports into one module providing all the normal JTAG debug and test functionality plus real-time access to system memory without halting the core or requiring any target resident code. The SWJ-DP interface has the following features:

- IEEE 1149.1-1990 compatible Test Access Port (TAP) controller
- Four-bit Instruction Register (IR) chain for storing JTAG instructions
- IEEE standard instructions: BYPASS, IDCODE, SAMPLE/PRELOAD, EXTEST and INTTEST
- ARM additional instructions: APACC, DPACC and ABORT
- Integrated ARM Serial Wire Debug (SWD)
 - Serial Wire JTAG Debug Port (SWJ-DP)
 - Flash Patch and Breakpoint (FPB) unit for implementing breakpoints

- Data Watchpoint and Trace (DWT) unit for implementing watchpoints, trigger resources, and system profiling
- Instrumentation Trace Macrocell (ITM) for support of printf style debugging
- Embedded Trace Macrocell (ETM) for instruction trace capture
- Trace Port Interface Unit (TPIU) for bridging to a Trace Port Analyzer

1.3.8 Packaging and Temperature

- Industrial-range (-40°C to 85°C) 64-pin RoHS-compliant LQFP package

1.4 LM4F231H5QR Microcontroller Hardware Details

Details on the pins and package can be found in the following sections:

- “Pin Diagram” on page 1290
- “Signal Tables” on page 1291
- “Operating Characteristics” on page 1321
- “Electrical Characteristics” on page 1322
- “Package Information” on page 1399

2 The Cortex-M4F Processor

The ARM® Cortex™-M4F processor provides a high-performance, low-cost platform that meets the system requirements of minimal memory implementation, reduced pin count, and low power consumption, while delivering outstanding computational performance and exceptional system response to interrupts. Features include:

- 32-bit ARM® Cortex™-M4F architecture optimized for small-footprint embedded applications
- 80-MHz operation; 100 DMIPS performance
- Outstanding processing performance combined with fast interrupt handling
- Thumb-2 mixed 16-/32-bit instruction set delivers the high performance expected of a 32-bit ARM core in a compact memory size usually associated with 8- and 16-bit devices, typically in the range of a few kilobytes of memory for microcontroller-class applications
 - Single-cycle multiply instruction and hardware divide
 - Atomic bit manipulation (bit-banding), delivering maximum memory utilization and streamlined peripheral control
 - Unaligned data access, enabling data to be efficiently packed into memory
- IEEE754-compliant single-precision Floating-Point Unit (FPU)
- 16-bit SIMD vector processing unit
- Fast code execution permits slower processor clock or increases sleep mode time
- Harvard architecture characterized by separate buses for instruction and data
- Efficient processor core, system and memories
- Hardware division and fast digital-signal-processing orientated multiply accumulate
- Saturating arithmetic for signal processing
- Deterministic, high-performance interrupt handling for time-critical applications
- Memory protection unit (MPU) to provide a privileged mode for protected operating system functionality
- Enhanced system debug with extensive breakpoint and trace capabilities
- Serial Wire Debug and Serial Wire Trace reduce the number of pins required for debugging and tracing
- Migration from the ARM7 processor family for better performance and power efficiency
- Optimized for single-cycle Flash memory usage
- Ultra-low power consumption with integrated sleep modes

The Stellaris® family of microcontrollers builds on this core to bring high-performance 32-bit computing to cost-sensitive embedded microcontroller applications, such as factory automation and control, industrial control power devices, building and home automation, and stepper motor control.

This chapter provides information on the Stellaris implementation of the Cortex-M4F processor, including the programming model, the memory model, the exception model, fault handling, and power management.

For technical details on the instruction set, see the *ARM® Cortex™-M4 Technical Reference Manual*.

2.1 Block Diagram

The Cortex-M4F processor is built on a high-performance processor core, with a 3-stage pipeline Harvard architecture, making it ideal for demanding embedded applications. The processor delivers exceptional power efficiency through an efficient instruction set and extensively optimized design, providing high-end processing hardware including IEEE754-compliant single-precision floating-point computation, a range of single-cycle and SIMD multiplication and multiply-with-accumulate capabilities, saturating arithmetic and dedicated hardware division.

To facilitate the design of cost-sensitive devices, the Cortex-M4F processor implements tightly coupled system components that reduce processor area while significantly improving interrupt handling and system debug capabilities. The Cortex-M4F processor implements a version of the Thumb® instruction set based on Thumb-2 technology, ensuring high code density and reduced program memory requirements. The Cortex-M4F instruction set provides the exceptional performance expected of a modern 32-bit architecture, with the high code density of 8-bit and 16-bit microcontrollers.

The Cortex-M4F processor closely integrates a nested interrupt controller (NVIC), to deliver industry-leading interrupt performance. The Stellaris NVIC includes a non-maskable interrupt (NMI) and provides eight interrupt priority levels. The tight integration of the processor core and NVIC provides fast execution of interrupt service routines (ISRs), dramatically reducing interrupt latency. The hardware stacking of registers and the ability to suspend load-multiple and store-multiple operations further reduce interrupt latency. Interrupt handlers do not require any assembler stubs which removes code overhead from the ISRs. Tail-chaining optimization also significantly reduces the overhead when switching from one ISR to another. To optimize low-power designs, the NVIC integrates with the sleep modes, including Deep-sleep mode, which enables the entire device to be rapidly powered down.

Figure 2-1. CPU Block Diagram

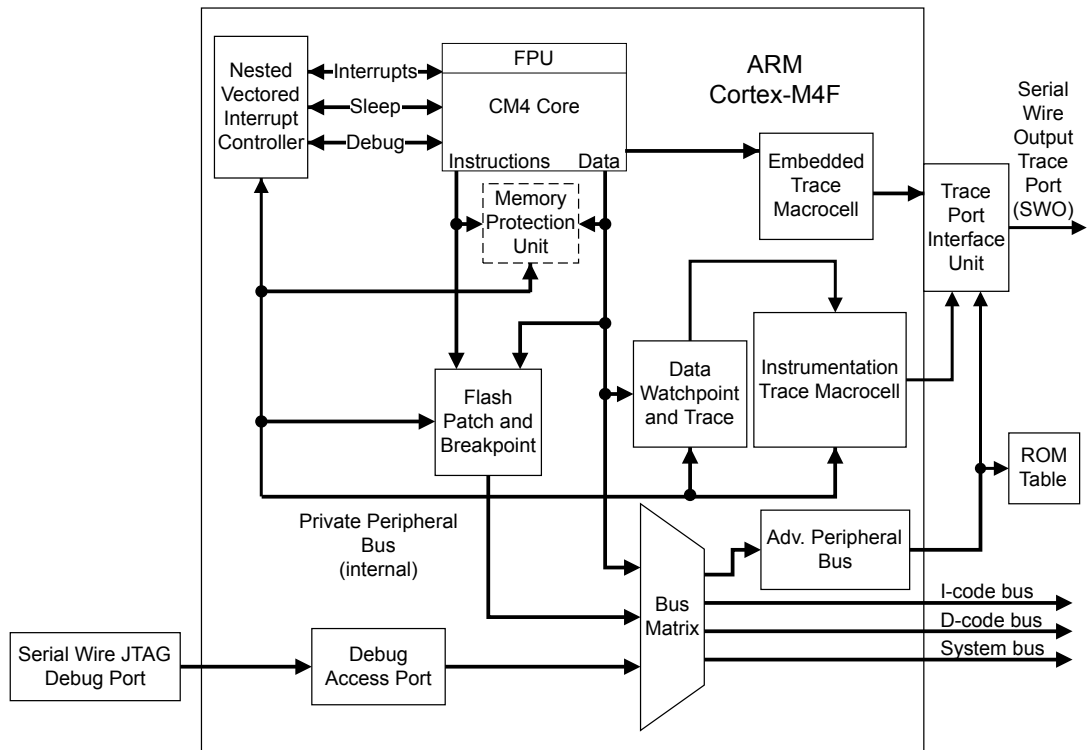

2.2 Overview

2.2.1 System-Level Interface

The Cortex-M4F processor provides multiple interfaces using AMBA® technology to provide high-speed, low-latency memory accesses. The core supports unaligned data accesses and implements atomic bit manipulation that enables faster peripheral controls, system spinlocks, and thread-safe Boolean data handling.

The Cortex-M4F processor has a memory protection unit (MPU) that provides fine-grain memory control, enabling applications to implement security privilege levels and separate code, data and stack on a task-by-task basis.

2.2.2 Integrated Configurable Debug

The Cortex-M4F processor implements a complete hardware debug solution, providing high system visibility of the processor and memory through either a traditional JTAG port or a 2-pin Serial Wire Debug (SWD) port that is ideal for microcontrollers and other small package devices. The Stellaris implementation replaces the ARM SW-DP and JTAG-DP with the ARM CoreSight™-compliant Serial Wire JTAG Debug Port (SWJ-DP) interface. The SWJ-DP interface combines the SWD and JTAG debug ports into one module. See the *ARM® Debug Interface V5 Architecture Specification* for details on SWJ-DP.

For system trace, the processor integrates an Instrumentation Trace Macrocell (ITM) alongside data watchpoints and a profiling unit. To enable simple and cost-effective profiling of the system trace events, a Serial Wire Viewer (SWV) can export a stream of software-generated messages, data trace, and profiling information through a single pin.

The Embedded Trace Macrocell (ETM) delivers unrivaled instruction trace capture in an area smaller than traditional trace units, enabling full instruction trace. For more details on the ARM ETM, see the *ARM® Embedded Trace Macrocell Architecture Specification*.

The Flash Patch and Breakpoint Unit (FPB) provides up to eight hardware breakpoint comparators that debuggers can use. The comparators in the FPB also provide remap functions of up to eight words in the program code in the CODE memory region. This enables applications stored in a read-only area of Flash memory to be patched in another area of on-chip SRAM or Flash memory. If a patch is required, the application programs the FPB to remap a number of addresses. When those addresses are accessed, the accesses are redirected to a remap table specified in the FPB configuration.

For more information on the Cortex-M4F debug capabilities, see the *ARM® Debug Interface V5 Architecture Specification*.

2.2.3 Trace Port Interface Unit (TPIU)

The TPIU acts as a bridge between the Cortex-M4F trace data from the ITM, and an off-chip Trace Port Analyzer, as shown in Figure 2-2 on page 73.

Figure 2-2. TPIU Block Diagram

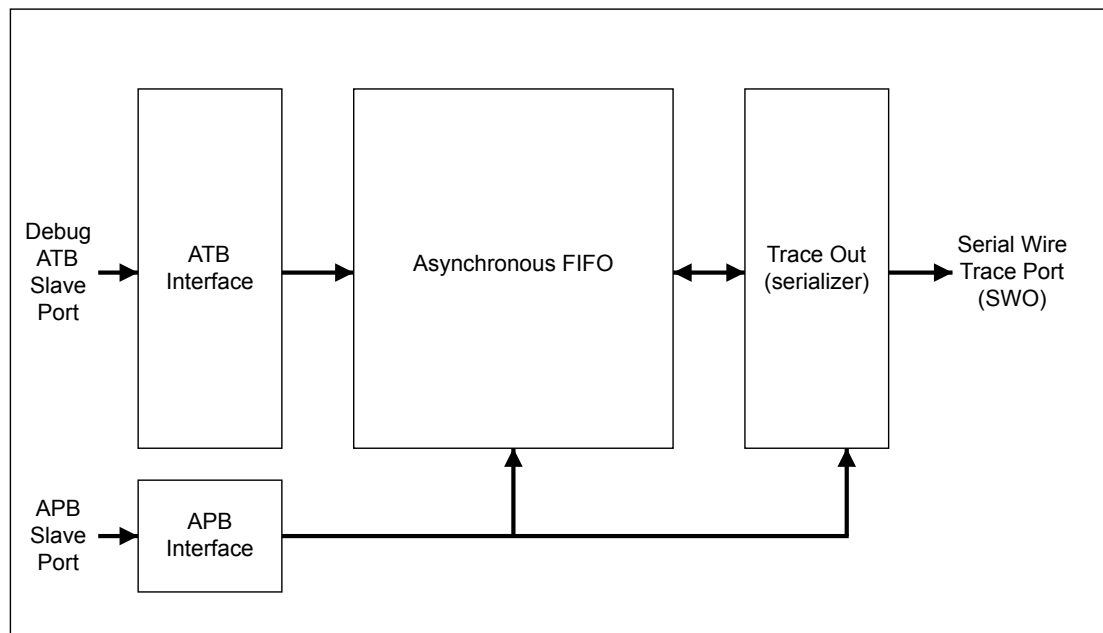

2.2.4 Cortex-M4F System Component Details

The Cortex-M4F includes the following system components:

- SysTick

A 24-bit count-down timer that can be used as a Real-Time Operating System (RTOS) tick timer or as a simple counter (see “System Timer (SysTick)” on page 124).

- Nested Vectored Interrupt Controller (NVIC)

An embedded interrupt controller that supports low latency interrupt processing (see “Nested Vectored Interrupt Controller (NVIC)” on page 125).

- System Control Block (SCB)

The programming model interface to the processor. The SCB provides system implementation information and system control, including configuration, control, and reporting of system exceptions (see “System Control Block (SCB)” on page 126).

- Memory Protection Unit (MPU)

Improves system reliability by defining the memory attributes for different memory regions. The MPU provides up to eight different regions and an optional predefined background region (see “Memory Protection Unit (MPU)” on page 126).

- Floating-Point Unit (FPU)

Fully supports single-precision add, subtract, multiply, divide, multiply and accumulate, and square-root operations. It also provides conversions between fixed-point and floating-point data formats, and floating-point constant instructions.

2.3 Programming Model

This section describes the Cortex-M4F programming model. In addition to the individual core register descriptions, information about the processor modes and privilege levels for software execution and stacks is included.

2.3.1 Processor Mode and Privilege Levels for Software Execution

The Cortex-M4F has two modes of operation:

- Thread mode

Used to execute application software. The processor enters Thread mode when it comes out of reset.

- Handler mode

Used to handle exceptions. When the processor has finished exception processing, it returns to Thread mode.

In addition, the Cortex-M4F has two privilege levels:

- Unprivileged

In this mode, software has the following restrictions:

- Limited access to the `MSR` and `MRS` instructions and no use of the `CPS` instruction
- No access to the system timer, NVIC, or system control block
- Possibly restricted access to memory or peripherals

- Privileged

In this mode, software can use all the instructions and has access to all resources.

In Thread mode, the **CONTROL** register (see page 89) controls whether software execution is privileged or unprivileged. In Handler mode, software execution is always privileged.

Only privileged software can write to the **CONTROL** register to change the privilege level for software execution in Thread mode. Unprivileged software can use the `SVC` instruction to make a supervisor call to transfer control to privileged software.

2.3.2 Stacks

The processor uses a full descending stack, meaning that the stack pointer indicates the last stacked item on the memory. When the processor pushes a new item onto the stack, it decrements the stack pointer and then writes the item to the new memory location. The processor implements two stacks: the main stack and the process stack, with a pointer for each held in independent registers (see the **SP** register on page 79).

In Thread mode, the **CONTROL** register (see page 89) controls whether the processor uses the main stack or the process stack. In Handler mode, the processor always uses the main stack. The options for processor operations are shown in Table 2-1 on page 75.

Table 2-1. Summary of Processor Mode, Privilege Level, and Stack Use

Processor Mode	Use	Privilege Level	Stack Used
Thread	Applications	Privileged or unprivileged ^a	Main stack or process stack ^a
Handler	Exception handlers	Always privileged	Main stack

a. See **CONTROL** (page 89).

2.3.3 Register Map

Figure 2-3 on page 76 shows the Cortex-M4F register set. Table 2-2 on page 76 lists the Core registers. The core registers are not memory mapped and are accessed by register name, so the base address is n/a (not applicable) and there is no offset.

Figure 2-3. Cortex-M4F Register Set

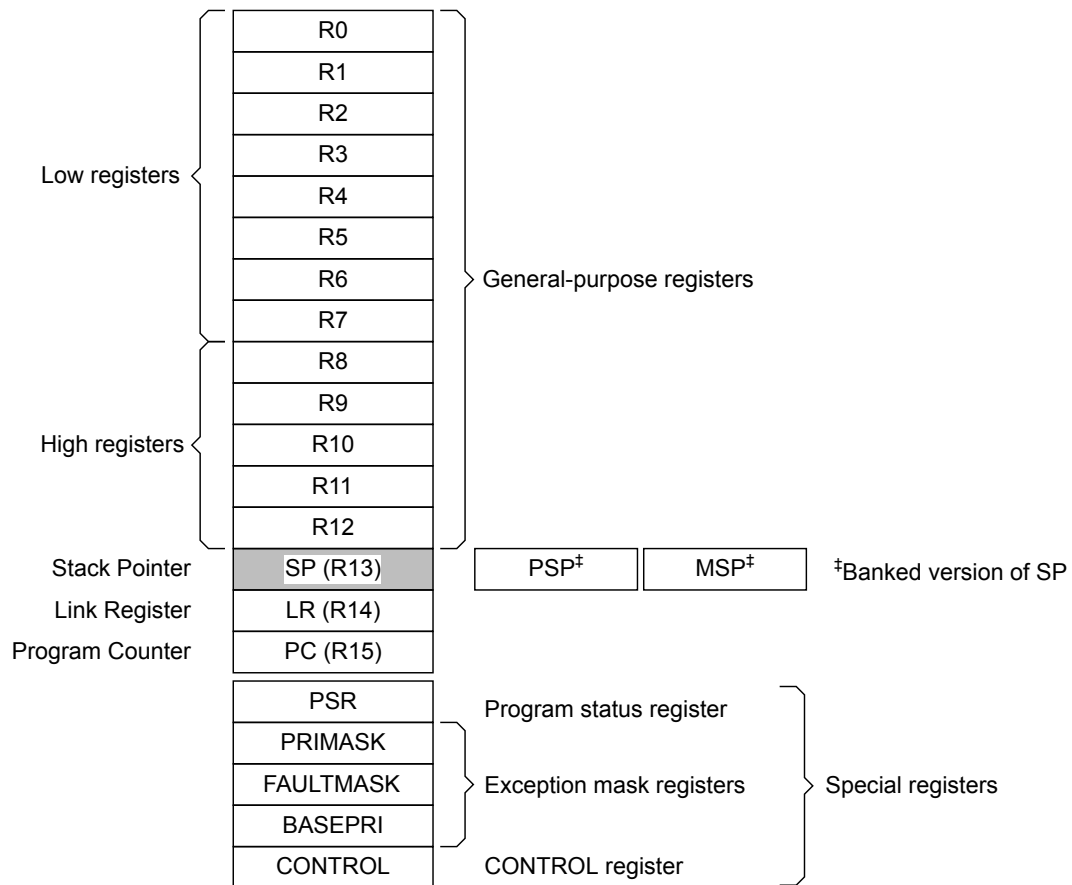

Table 2-2. Processor Register Map

Offset	Name	Type	Reset	Description	See page
-	R0	R/W	-	Cortex General-Purpose Register 0	78
-	R1	R/W	-	Cortex General-Purpose Register 1	78
-	R2	R/W	-	Cortex General-Purpose Register 2	78
-	R3	R/W	-	Cortex General-Purpose Register 3	78
-	R4	R/W	-	Cortex General-Purpose Register 4	78
-	R5	R/W	-	Cortex General-Purpose Register 5	78
-	R6	R/W	-	Cortex General-Purpose Register 6	78
-	R7	R/W	-	Cortex General-Purpose Register 7	78
-	R8	R/W	-	Cortex General-Purpose Register 8	78
-	R9	R/W	-	Cortex General-Purpose Register 9	78
-	R10	R/W	-	Cortex General-Purpose Register 10	78
-	R11	R/W	-	Cortex General-Purpose Register 11	78

Table 2-2. Processor Register Map (continued)

Offset	Name	Type	Reset	Description	See page
-	R12	R/W	-	Cortex General-Purpose Register 12	78
-	SP	R/W	-	Stack Pointer	79
-	LR	R/W	0xFFFF.FFFF	Link Register	80
-	PC	R/W	-	Program Counter	81
-	PSR	R/W	0x0100.0000	Program Status Register	82
-	PRIMASK	R/W	0x0000.0000	Priority Mask Register	86
-	FAULTMASK	R/W	0x0000.0000	Fault Mask Register	87
-	BASEPRI	R/W	0x0000.0000	Base Priority Mask Register	88
-	CONTROL	R/W	0x0000.0000	Control Register	89
-	FPSC	R/W	-	Floating-Point Status Control	91

2.3.4 Register Descriptions

This section lists and describes the Cortex-M4F registers, in the order shown in Figure 2-3 on page 76. The core registers are not memory mapped and are accessed by register name rather than offset.

Note: The register type shown in the register descriptions refers to type during program execution in Thread mode and Handler mode. Debug access can differ.

- Register 1: Cortex General-Purpose Register 0 (R0)**
- Register 2: Cortex General-Purpose Register 1 (R1)**
- Register 3: Cortex General-Purpose Register 2 (R2)**
- Register 4: Cortex General-Purpose Register 3 (R3)**
- Register 5: Cortex General-Purpose Register 4 (R4)**
- Register 6: Cortex General-Purpose Register 5 (R5)**
- Register 7: Cortex General-Purpose Register 6 (R6)**
- Register 8: Cortex General-Purpose Register 7 (R7)**
- Register 9: Cortex General-Purpose Register 8 (R8)**
- Register 10: Cortex General-Purpose Register 9 (R9)**
- Register 11: Cortex General-Purpose Register 10 (R10)**
- Register 12: Cortex General-Purpose Register 11 (R11)**
- Register 13: Cortex General-Purpose Register 12 (R12)**

The **Rn** registers are 32-bit general-purpose registers for data operations and can be accessed from either privileged or unprivileged mode.

Cortex General-Purpose Register 0 (R0)

Type R/W, reset -

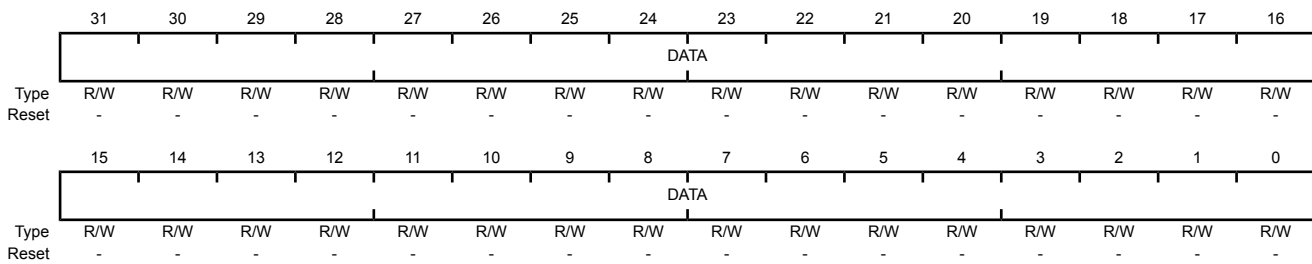

Bit/Field	Name	Type	Reset	Description
31:0	DATA	R/W	-	Register data.

Register 14: Stack Pointer (SP)

The **Stack Pointer (SP)** is register R13. In Thread mode, the function of this register changes depending on the `ASP` bit in the **Control Register (CONTROL)** register. When the `ASP` bit is clear, this register is the **Main Stack Pointer (MSP)**. When the `ASP` bit is set, this register is the **Process Stack Pointer (PSP)**. On reset, the `ASP` bit is clear, and the processor loads the **MSP** with the value from address `0x0000.0000`. The **MSP** can only be accessed in privileged mode; the **PSP** can be accessed in either privileged or unprivileged mode.

Stack Pointer (SP)

Type R/W, reset -

	31	30	29	28	27	26	25	24	23	22	21	20	19	18	17	16
	SP															
Type	R/W	R/W	R/W	R/W	R/W	R/W	R/W	R/W	R/W	R/W	R/W	R/W	R/W	R/W	R/W	R/W
Reset	-	-	-	-	-	-	-	-	-	-	-	-	-	-	-	-
	15	14	13	12	11	10	9	8	7	6	5	4	3	2	1	0
	SP															
Type	R/W	R/W	R/W	R/W	R/W	R/W	R/W	R/W	R/W	R/W	R/W	R/W	R/W	R/W	R/W	R/W
Reset	-	-	-	-	-	-	-	-	-	-	-	-	-	-	-	-

Bit/Field	Name	Type	Reset	Description
31:0	SP	R/W	-	This field is the address of the stack pointer.

Register 15: Link Register (LR)

The **Link Register (LR)** is register R14, and it stores the return information for subroutines, function calls, and exceptions. **LR** can be accessed from either privileged or unprivileged mode.

EXC_RETURN is loaded into **LR** on exception entry. See Table 2-10 on page 112 for the values and description.

Link Register (LR)

Type R/W, reset 0xFFFF.FFFF

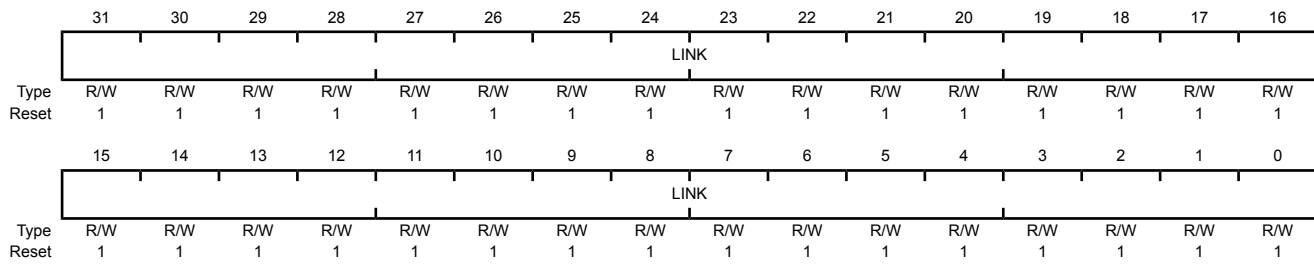

Bit/Field	Name	Type	Reset	Description
31:0	LINK	R/W	0xFFFF.FFFF	This field is the return address.

Register 16: Program Counter (PC)

The **Program Counter (PC)** is register R15, and it contains the current program address. On reset, the processor loads the **PC** with the value of the reset vector, which is at address 0x0000.0004. Bit 0 of the reset vector is loaded into the **THUMB** bit of the **EPSR** at reset and must be 1. The **PC** register can be accessed in either privileged or unprivileged mode.

Program Counter (PC)

Type R/W, reset -

	31	30	29	28	27	26	25	24	23	22	21	20	19	18	17	16
	PC															
Type	R/W	R/W	R/W	R/W	R/W	R/W	R/W	R/W	R/W	R/W	R/W	R/W	R/W	R/W	R/W	R/W
Reset	-	-	-	-	-	-	-	-	-	-	-	-	-	-	-	-
	15	14	13	12	11	10	9	8	7	6	5	4	3	2	1	0
	PC															
Type	R/W	R/W	R/W	R/W	R/W	R/W	R/W	R/W	R/W	R/W	R/W	R/W	R/W	R/W	R/W	R/W
Reset	-	-	-	-	-	-	-	-	-	-	-	-	-	-	-	-

Bit/Field	Name	Type	Reset	Description
31:0	PC	R/W	-	This field is the current program address.

Register 17: Program Status Register (PSR)

Note: This register is also referred to as **xPSR**.

The **Program Status Register (PSR)** has three functions, and the register bits are assigned to the different functions:

- **Application Program Status Register (APSR)**, bits 31:27, bits 19:16
- **Execution Program Status Register (EPSR)**, bits 26:24, 15:10
- **Interrupt Program Status Register (IPSR)**, bits 7:0

The **PSR**, **IPSR**, and **EPSR** registers can only be accessed in privileged mode; the **APSR** register can be accessed in either privileged or unprivileged mode.

APSR contains the current state of the condition flags from previous instruction executions.

EPSR contains the Thumb state bit and the execution state bits for the If-Then (**IT**) instruction or the Interruptible-Continuable Instruction (**ICI**) field for an interrupted load multiple or store multiple instruction. Attempts to read the **EPSR** directly through application software using the **MSR** instruction always return zero. Attempts to write the **EPSR** using the **MSR** instruction in application software are always ignored. Fault handlers can examine the **EPSR** value in the stacked **PSR** to determine the operation that faulted (see “Exception Entry and Return” on page 109).

IPSR contains the exception type number of the current Interrupt Service Routine (**ISR**).

These registers can be accessed individually or as a combination of any two or all three registers, using the register name as an argument to the **MSR** or **MRS** instructions. For example, all of the registers can be read using **PSR** with the **MRS** instruction, or **APSR** only can be written to using **APSR** with the **MSR** instruction. page 82 shows the possible register combinations for the **PSR**. See the **MRS** and **MSR** instruction descriptions in the *Cortex™-M3/M4 Instruction Set Technical User's Manual* for more information about how to access the program status registers.

Table 2-3. PSR Register Combinations

Register	Type	Combination
PSR	R/W ^{a, b}	APSR , EPSR , and IPSR
IEPSR	RO	EPSR and IPSR
IAPSR	R/W ^a	APSR and IPSR
EAPSR	R/W ^b	APSR and EPSR

a. The processor ignores writes to the **IPSR** bits.

b. Reads of the **EPSR** bits return zero, and the processor ignores writes to these bits.

Program Status Register (PSR)

Type R/W, reset 0x0100.0000

	31	30	29	28	27	26	25	24	23	22	21	20	19	18	17	16
	N	Z	C	V	Q	ICI / IT		THUMB	reserved				GE			
Type	R/W	R/W	R/W	R/W	R/W	RO	RO	RO	RO	RO	RO	RO	R/W	R/W	R/W	R/W
Reset	0	0	0	0	0	0	0	1	0	0	0	0	0	0	0	0
	15	14	13	12	11	10	9	8	7	6	5	4	3	2	1	0
	ICI / IT				reserved				ISRNUM							
Type	RO	RO	RO	RO	RO	RO	RO	RO	RO	RO	RO	RO	RO	RO	RO	RO
Reset	0	0	0	0	0	0	0	0	0	0	0	0	0	0	0	0

Bit/Field	Name	Type	Reset	Description
31	N	R/W	0	<p>APSR Negative or Less Flag</p> <p>Value Description</p> <p>1 The previous operation result was negative or less than.</p> <p>0 The previous operation result was positive, zero, greater than, or equal.</p> <p>The value of this bit is only meaningful when accessing PSR or APSR.</p>
30	Z	R/W	0	<p>APSR Zero Flag</p> <p>Value Description</p> <p>1 The previous operation result was zero.</p> <p>0 The previous operation result was non-zero.</p> <p>The value of this bit is only meaningful when accessing PSR or APSR.</p>
29	C	R/W	0	<p>APSR Carry or Borrow Flag</p> <p>Value Description</p> <p>1 The previous add operation resulted in a carry bit or the previous subtract operation did not result in a borrow bit.</p> <p>0 The previous add operation did not result in a carry bit or the previous subtract operation resulted in a borrow bit.</p> <p>The value of this bit is only meaningful when accessing PSR or APSR.</p>
28	V	R/W	0	<p>APSR Overflow Flag</p> <p>Value Description</p> <p>1 The previous operation resulted in an overflow.</p> <p>0 The previous operation did not result in an overflow.</p> <p>The value of this bit is only meaningful when accessing PSR or APSR.</p>
27	Q	R/W	0	<p>APSR DSP Overflow and Saturation Flag</p> <p>Value Description</p> <p>1 DSP Overflow or saturation has occurred.</p> <p>0 DSP overflow or saturation has not occurred since reset or since the bit was last cleared.</p> <p>The value of this bit is only meaningful when accessing PSR or APSR. This bit is cleared by software using an MRS instruction.</p>

Bit/Field	Name	Type	Reset	Description
26:25	ICI / IT	RO	0x0	<p>EPSR ICI / IT status</p> <p>These bits, along with bits 15:10, contain the Interruptible-Continuable Instruction (ICI) field for an interrupted load multiple or store multiple instruction or the execution state bits of the IT instruction.</p> <p>When EPSR holds the ICI execution state, bits 26:25 are zero.</p> <p>The If-Then block contains up to four instructions following an IT instruction. Each instruction in the block is conditional. The conditions for the instructions are either all the same, or some can be the inverse of others. See the <i>Cortex™-M3/M4 Instruction Set Technical User's Manual</i> for more information.</p> <p>The value of this field is only meaningful when accessing PSR or EPSR.</p>
24	THUMB	RO	1	<p>EPSR Thumb State</p> <p>This bit indicates the Thumb state and should always be set.</p> <p>The following can clear the THUMB bit:</p> <ul style="list-style-type: none"> ■ The BLX, BX and POP{PC} instructions ■ Restoration from the stacked xPSR value on an exception return ■ Bit 0 of the vector value on an exception entry or reset <p>Attempting to execute instructions when this bit is clear results in a fault or lockup. See "Lockup" on page 114 for more information.</p> <p>The value of this bit is only meaningful when accessing PSR or EPSR.</p>
23:20	reserved	RO	0x00	<p>Software should not rely on the value of a reserved bit. To provide compatibility with future products, the value of a reserved bit should be preserved across a read-modify-write operation.</p>
19:16	GE	R/W	0x0	<p>Greater Than or Equal Flags</p> <p>See the description of the SEL instruction in the <i>Cortex™-M3/M4 Instruction Set Technical User's Manual</i> for more information.</p> <p>The value of this field is only meaningful when accessing PSR or APSR.</p>
15:10	ICI / IT	RO	0x0	<p>EPSR ICI / IT status</p> <p>These bits, along with bits 26:25, contain the Interruptible-Continuable Instruction (ICI) field for an interrupted load multiple or store multiple instruction or the execution state bits of the IT instruction.</p> <p>When an interrupt occurs during the execution of an LDM, STM, PUSH POP, VLDM, VSTM, VPUSH, or VPOP instruction, the processor stops the load multiple or store multiple instruction operation temporarily and stores the next register operand in the multiple operation to bits 15:12. After servicing the interrupt, the processor returns to the register pointed to by bits 15:12 and resumes execution of the multiple load or store instruction. When EPSR holds the ICI execution state, bits 11:10 are zero.</p> <p>The If-Then block contains up to four instructions following a 16-bit IT instruction. Each instruction in the block is conditional. The conditions for the instructions are either all the same, or some can be the inverse of others. See the <i>Cortex™-M3/M4 Instruction Set Technical User's Manual</i> for more information.</p> <p>The value of this field is only meaningful when accessing PSR or EPSR.</p>
9:8	reserved	RO	0x0	<p>Software should not rely on the value of a reserved bit. To provide compatibility with future products, the value of a reserved bit should be preserved across a read-modify-write operation.</p>

Bit/Field	Name	Type	Reset	Description																																				
7:0	ISRNUM	RO	0x00	<p>IPSR ISR Number</p> <p>This field contains the exception type number of the current Interrupt Service Routine (ISR).</p> <table border="1"> <thead> <tr> <th>Value</th> <th>Description</th> </tr> </thead> <tbody> <tr> <td>0x00</td> <td>Thread mode</td> </tr> <tr> <td>0x01</td> <td>Reserved</td> </tr> <tr> <td>0x02</td> <td>NMI</td> </tr> <tr> <td>0x03</td> <td>Hard fault</td> </tr> <tr> <td>0x04</td> <td>Memory management fault</td> </tr> <tr> <td>0x05</td> <td>Bus fault</td> </tr> <tr> <td>0x06</td> <td>Usage fault</td> </tr> <tr> <td>0x07-0x0A</td> <td>Reserved</td> </tr> <tr> <td>0x0B</td> <td>SVCall</td> </tr> <tr> <td>0x0C</td> <td>Reserved for Debug</td> </tr> <tr> <td>0x0D</td> <td>Reserved</td> </tr> <tr> <td>0x0E</td> <td>PendSV</td> </tr> <tr> <td>0x0F</td> <td>SysTick</td> </tr> <tr> <td>0x10</td> <td>Interrupt Vector 0</td> </tr> <tr> <td>0x11</td> <td>Interrupt Vector 1</td> </tr> <tr> <td>...</td> <td>...</td> </tr> <tr> <td>0x9A</td> <td>Interrupt Vector 138</td> </tr> </tbody> </table>	Value	Description	0x00	Thread mode	0x01	Reserved	0x02	NMI	0x03	Hard fault	0x04	Memory management fault	0x05	Bus fault	0x06	Usage fault	0x07-0x0A	Reserved	0x0B	SVCall	0x0C	Reserved for Debug	0x0D	Reserved	0x0E	PendSV	0x0F	SysTick	0x10	Interrupt Vector 0	0x11	Interrupt Vector 1	0x9A	Interrupt Vector 138
Value	Description																																							
0x00	Thread mode																																							
0x01	Reserved																																							
0x02	NMI																																							
0x03	Hard fault																																							
0x04	Memory management fault																																							
0x05	Bus fault																																							
0x06	Usage fault																																							
0x07-0x0A	Reserved																																							
0x0B	SVCall																																							
0x0C	Reserved for Debug																																							
0x0D	Reserved																																							
0x0E	PendSV																																							
0x0F	SysTick																																							
0x10	Interrupt Vector 0																																							
0x11	Interrupt Vector 1																																							
...	...																																							
0x9A	Interrupt Vector 138																																							

See "Exception Types" on page 103 for more information.

The value of this field is only meaningful when accessing **PSR** or **IPSR**.

Register 18: Priority Mask Register (PRIMASK)

The **PRIMASK** register prevents activation of all exceptions with programmable priority. Reset, non-maskable interrupt (NMI), and hard fault are the only exceptions with fixed priority. Exceptions should be disabled when they might impact the timing of critical tasks. This register is only accessible in privileged mode. The **MSR** and **MRS** instructions are used to access the **PRIMASK** register, and the **CPS** instruction may be used to change the value of the **PRIMASK** register. See the *Cortex™-M3/M4 Instruction Set Technical User's Manual* for more information on these instructions. For more information on exception priority levels, see “Exception Types” on page 103.

Priority Mask Register (PRIMASK)

Type R/W, reset 0x0000.0000

	31	30	29	28	27	26	25	24	23	22	21	20	19	18	17	16
	reserved															
Type	RO	RO	RO	RO	RO	RO	RO	RO	RO	RO	RO	RO	RO	RO	RO	RO
Reset	0	0	0	0	0	0	0	0	0	0	0	0	0	0	0	0
	15	14	13	12	11	10	9	8	7	6	5	4	3	2	1	0
	reserved															PRIMASK
Type	RO	RO	RO	RO	RO	RO	RO	RO	RO	RO	RO	RO	RO	RO	RO	R/W
Reset	0	0	0	0	0	0	0	0	0	0	0	0	0	0	0	0

Bit/Field	Name	Type	Reset	Description
31:1	reserved	RO	0x0000.000	Software should not rely on the value of a reserved bit. To provide compatibility with future products, the value of a reserved bit should be preserved across a read-modify-write operation.
0	PRIMASK	R/W	0	Priority Mask
				Value Description
				1 Prevents the activation of all exceptions with configurable priority.
				0 No effect.

Register 19: Fault Mask Register (FAULTMASK)

The **FAULTMASK** register prevents activation of all exceptions except for the Non-Maskable Interrupt (NMI). Exceptions should be disabled when they might impact the timing of critical tasks. This register is only accessible in privileged mode. The **MSR** and **MRS** instructions are used to access the **FAULTMASK** register, and the **CPS** instruction may be used to change the value of the **FAULTMASK** register. See the *Cortex™-M3/M4 Instruction Set Technical User's Manual* for more information on these instructions. For more information on exception priority levels, see “Exception Types” on page 103.

Fault Mask Register (FAULTMASK)

Type R/W, reset 0x0000.0000

	31	30	29	28	27	26	25	24	23	22	21	20	19	18	17	16
	reserved															
Type	RO	RO	RO	RO	RO	RO	RO	RO	RO	RO	RO	RO	RO	RO	RO	RO
Reset	0	0	0	0	0	0	0	0	0	0	0	0	0	0	0	0
	15	14	13	12	11	10	9	8	7	6	5	4	3	2	1	0
	reserved															FAULTMASK
Type	RO	RO	RO	RO	RO	RO	RO	RO	RO	RO	RO	RO	RO	RO	RO	R/W
Reset	0	0	0	0	0	0	0	0	0	0	0	0	0	0	0	0

Bit/Field	Name	Type	Reset	Description
31:1	reserved	RO	0x0000.000	Software should not rely on the value of a reserved bit. To provide compatibility with future products, the value of a reserved bit should be preserved across a read-modify-write operation.
0	FAULTMASK	R/W	0	Fault Mask

Value Description

1	Prevents the activation of all exceptions except for NMI.
0	No effect.

The processor clears the **FAULTMASK** bit on exit from any exception handler except the NMI handler.

Register 20: Base Priority Mask Register (BASEPRI)

The **BASEPRI** register defines the minimum priority for exception processing. When **BASEPRI** is set to a nonzero value, it prevents the activation of all exceptions with the same or lower priority level as the **BASEPRI** value. Exceptions should be disabled when they might impact the timing of critical tasks. This register is only accessible in privileged mode. For more information on exception priority levels, see “Exception Types” on page 103.

Base Priority Mask Register (BASEPRI)

Type R/W, reset 0x0000.0000

	31	30	29	28	27	26	25	24	23	22	21	20	19	18	17	16
	reserved															
Type	RO	RO	RO	RO	RO	RO	RO	RO	RO	RO	RO	RO	RO	RO	RO	RO
Reset	0	0	0	0	0	0	0	0	0	0	0	0	0	0	0	0
	15	14	13	12	11	10	9	8	7	6	5	4	3	2	1	0
	reserved								BASEPRI			reserved				
Type	RO	RO	RO	RO	RO	RO	RO	RO	R/W	R/W	R/W	RO	RO	RO	RO	RO
Reset	0	0	0	0	0	0	0	0	0	0	0	0	0	0	0	0

Bit/Field	Name	Type	Reset	Description																		
31:8	reserved	RO	0x0000.00	Software should not rely on the value of a reserved bit. To provide compatibility with future products, the value of a reserved bit should be preserved across a read-modify-write operation.																		
7:5	BASEPRI	R/W	0x0	<p>Base Priority</p> <p>Any exception that has a programmable priority level with the same or lower priority as the value of this field is masked. The PRIMASK register can be used to mask all exceptions with programmable priority levels. Higher priority exceptions have lower priority levels.</p> <table border="0"> <tr> <td>Value</td> <td>Description</td> </tr> <tr> <td>0x0</td> <td>All exceptions are unmasked.</td> </tr> <tr> <td>0x1</td> <td>All exceptions with priority level 1-7 are masked.</td> </tr> <tr> <td>0x2</td> <td>All exceptions with priority level 2-7 are masked.</td> </tr> <tr> <td>0x3</td> <td>All exceptions with priority level 3-7 are masked.</td> </tr> <tr> <td>0x4</td> <td>All exceptions with priority level 4-7 are masked.</td> </tr> <tr> <td>0x5</td> <td>All exceptions with priority level 5-7 are masked.</td> </tr> <tr> <td>0x6</td> <td>All exceptions with priority level 6-7 are masked.</td> </tr> <tr> <td>0x7</td> <td>All exceptions with priority level 7 are masked.</td> </tr> </table>	Value	Description	0x0	All exceptions are unmasked.	0x1	All exceptions with priority level 1-7 are masked.	0x2	All exceptions with priority level 2-7 are masked.	0x3	All exceptions with priority level 3-7 are masked.	0x4	All exceptions with priority level 4-7 are masked.	0x5	All exceptions with priority level 5-7 are masked.	0x6	All exceptions with priority level 6-7 are masked.	0x7	All exceptions with priority level 7 are masked.
Value	Description																					
0x0	All exceptions are unmasked.																					
0x1	All exceptions with priority level 1-7 are masked.																					
0x2	All exceptions with priority level 2-7 are masked.																					
0x3	All exceptions with priority level 3-7 are masked.																					
0x4	All exceptions with priority level 4-7 are masked.																					
0x5	All exceptions with priority level 5-7 are masked.																					
0x6	All exceptions with priority level 6-7 are masked.																					
0x7	All exceptions with priority level 7 are masked.																					
4:0	reserved	RO	0x0	Software should not rely on the value of a reserved bit. To provide compatibility with future products, the value of a reserved bit should be preserved across a read-modify-write operation.																		

Register 21: Control Register (CONTROL)

The **CONTROL** register controls the stack used and the privilege level for software execution when the processor is in Thread mode, and indicates whether the FPU state is active. This register is only accessible in privileged mode.

Handler mode always uses **MSP**, so the processor ignores explicit writes to the **ASP** bit of the **CONTROL** register when in Handler mode. The exception entry and return mechanisms automatically update the **CONTROL** register based on the **EXC_RETURN** value (see Table 2-10 on page 112). In an OS environment, threads running in Thread mode should use the process stack and the kernel and exception handlers should use the main stack. By default, Thread mode uses **MSP**. To switch the stack pointer used in Thread mode to **PSP**, either use the **MSR** instruction to set the **ASP** bit, as detailed in the *Cortex™-M3/M4 Instruction Set Technical User's Manual*, or perform an exception return to Thread mode with the appropriate **EXC_RETURN** value, as shown in Table 2-10 on page 112.

Note: When changing the stack pointer, software must use an **ISB** instruction immediately after the **MSR** instruction, ensuring that instructions after the **ISB** execute use the new stack pointer. See the *Cortex™-M3/M4 Instruction Set Technical User's Manual*.

Control Register (CONTROL)

Type R/W, reset 0x0000.0000

	31	30	29	28	27	26	25	24	23	22	21	20	19	18	17	16
	reserved															
Type	RO	RO	RO	RO	RO	RO	RO	RO	RO	RO	RO	RO	RO	RO	RO	RO
Reset	0	0	0	0	0	0	0	0	0	0	0	0	0	0	0	0
	15	14	13	12	11	10	9	8	7	6	5	4	3	2	1	0
	reserved													FPCA	ASP	TMPL
Type	RO	RO	RO	RO	RO	RO	RO	RO	RO	RO	RO	RO	RO	R/W	R/W	R/W
Reset	0	0	0	0	0	0	0	0	0	0	0	0	0	0	0	0

Bit/Field	Name	Type	Reset	Description
31:3	reserved	RO	0x0000.000	Software should not rely on the value of a reserved bit. To provide compatibility with future products, the value of a reserved bit should be preserved across a read-modify-write operation.
2	FPCA	R/W	0	Floating-Point Context Active
				Value Description
				1 Floating-point context active
				0 No floating-point context active
				The Cortex-M4F uses this bit to determine whether to preserve floating-point state when processing an exception.

Important: Two bits control when **FPCA** can be enabled: the **ASPEN** bit in the **Floating-Point Context Control (FPCC)** register and the **DISFPCA** bit in the **Auxiliary Control (ACTLR)** register.

Bit/Field	Name	Type	Reset	Description
1	ASP	R/W	0	Active Stack Pointer Value Description 1 PSP is the current stack pointer. 0 MSP is the current stack pointer In Handler mode, this bit reads as zero and ignores writes. The Cortex-M4F updates this bit automatically on exception return.
0	TMPL	R/W	0	Thread Mode Privilege Level Value Description 1 Unprivileged software can be executed in Thread mode. 0 Only privileged software can be executed in Thread mode.

Register 22: Floating-Point Status Control (FPSC)

The **FPSC** register provides all necessary user-level control of the floating-point system.

Floating-Point Status Control (FPSC)

Type R/W, reset -

	31	30	29	28	27	26	25	24	23	22	21	20	19	18	17	16
	N	Z	C	V	reserved	AHP	DN	FZ	RMODE		reserved					
Type	R/W	R/W	R/W	R/W	RO	R/W	R/W	R/W	R/W	R/W	RO	RO	RO	RO	RO	RO
Reset	-	-	-	-	0	-	-	-	-	-	0	0	0	0	0	0
	15	14	13	12	11	10	9	8	7	6	5	4	3	2	1	0
	reserved								IDC	reserved		IXC	UFC	OFC	DZC	IOC
Type	RO	RO	RO	RO	RO	RO	RO	RO	R/W	RO	RO	R/W	R/W	R/W	R/W	R/W
Reset	0	0	0	0	0	0	0	0	-	0	0	-	-	-	-	-

Bit/Field	Name	Type	Reset	Description
31	N	R/W	-	Negative Condition Code Flag Floating-point comparison operations update this condition code flag.
30	Z	R/W	-	Zero Condition Code Flag Floating-point comparison operations update this condition code flag.
29	C	R/W	-	Carry Condition Code Flag Floating-point comparison operations update this condition code flag.
28	V	R/W	-	Overflow Condition Code Flag Floating-point comparison operations update this condition code flag.
27	reserved	RO	0	Software should not rely on the value of a reserved bit. To provide compatibility with future products, the value of a reserved bit should be preserved across a read-modify-write operation.
26	AHP	R/W	-	Alternative Half-Precision When set, alternative half-precision format is selected. When clear, IEEE half-precision format is selected. The AHP bit in the FPDSC register holds the default value for this bit.
25	DN	R/W	-	Default NaN Mode When set, any operation involving one or more NaNs returns the Default NaN. When clear, NaN operands propagate through to the output of a floating-point operation. The DN bit in the FPDSC register holds the default value for this bit.
24	FZ	R/W	-	Flush-to-Zero Mode When set, Flush-to-Zero mode is enabled. When clear, Flush-to-Zero mode is disabled and the behavior of the floating-point system is fully compliant with the IEEE 754 standard. The FZ bit in the FPDSC register holds the default value for this bit.

Bit/Field	Name	Type	Reset	Description
23:22	RMODE	R/W	-	<p>Rounding Mode</p> <p>The specified rounding mode is used by almost all floating-point instructions.</p> <p>The RMODE bit in the FPDSC register holds the default value for this bit.</p> <p>Value Description</p> <p>0x0 Round to Nearest (RN) mode</p> <p>0x1 Round towards Plus Infinity (RP) mode</p> <p>0x2 Round towards Minus Infinity (RM) mode</p> <p>0x3 Round towards Zero (RZ) mode</p>
21:8	reserved	RO	0x0	Software should not rely on the value of a reserved bit. To provide compatibility with future products, the value of a reserved bit should be preserved across a read-modify-write operation.
7	IDC	R/W	-	<p>Input Denormal Cumulative Exception</p> <p>When set, indicates this exception has occurred since 0 was last written to this bit.</p>
6:5	reserved	RO	0x0	Software should not rely on the value of a reserved bit. To provide compatibility with future products, the value of a reserved bit should be preserved across a read-modify-write operation.
4	IXC	R/W	-	<p>Inexact Cumulative Exception</p> <p>When set, indicates this exception has occurred since 0 was last written to this bit.</p>
3	UFC	R/W	-	<p>Underflow Cumulative Exception</p> <p>When set, indicates this exception has occurred since 0 was last written to this bit.</p>
2	OFC	R/W	-	<p>Overflow Cumulative Exception</p> <p>When set, indicates this exception has occurred since 0 was last written to this bit.</p>
1	DZC	R/W	-	<p>Division by Zero Cumulative Exception</p> <p>When set, indicates this exception has occurred since 0 was last written to this bit.</p>
0	IOC	R/W	-	<p>Invalid Operation Cumulative Exception</p> <p>When set, indicates this exception has occurred since 0 was last written to this bit.</p>

2.3.5 Exceptions and Interrupts

The Cortex-M4F processor supports interrupts and system exceptions. The processor and the Nested Vectored Interrupt Controller (NVIC) prioritize and handle all exceptions. An exception changes the normal flow of software control. The processor uses Handler mode to handle all exceptions except for reset. See “Exception Entry and Return” on page 109 for more information.

The NVIC registers control interrupt handling. See “Nested Vectored Interrupt Controller (NVIC)” on page 125 for more information.

2.3.6 Data Types

The Cortex-M4F supports 32-bit words, 16-bit halfwords, and 8-bit bytes. The processor also supports 64-bit data transfer instructions. All instruction and data memory accesses are little endian. See “Memory Regions, Types and Attributes” on page 96 for more information.

2.4 Memory Model

This section describes the processor memory map, the behavior of memory accesses, and the bit-banding features. The processor has a fixed memory map that provides up to 4 GB of addressable memory.

The memory map for the LM4F231H5QR controller is provided in Table 2-4 on page 93. In this manual, register addresses are given as a hexadecimal increment, relative to the module’s base address as shown in the memory map.

The regions for SRAM and peripherals include bit-band regions. Bit-banding provides atomic operations to bit data (see “Bit-Banding” on page 98).

The processor reserves regions of the Private peripheral bus (PPB) address range for core peripheral registers (see “Cortex-M4 Peripherals” on page 123).

Note: Within the memory map, all reserved space returns a bus fault when read or written.

Table 2-4. Memory Map

Start	End	Description	For details, see page ...
Memory			
0x0000.0000	0x0003.FFFF	On-chip Flash	516
0x0004.0000	0x00FF.FFFF	Reserved	-
0x0100.0000	0x1FFF.FFFF	Reserved for ROM	503
0x2000.0000	0x2000.7FFF	Bit-banded on-chip SRAM	502
0x2000.8000	0x21FF.FFFF	Reserved	-
0x2200.0000	0x220F.FFFF	Bit-band alias of bit-banded on-chip SRAM starting at 0x2000.0000	502
0x2210.0000	0x3FFF.FFFF	Reserved	-
FIRM Peripherals			
0x4000.0000	0x4000.0FFF	Watchdog timer 0	750
0x4000.1000	0x4000.1FFF	Watchdog timer 1	750
0x4000.2000	0x4000.3FFF	Reserved	-
0x4000.4000	0x4000.4FFF	GPIO Port A	634
0x4000.5000	0x4000.5FFF	GPIO Port B	634
0x4000.6000	0x4000.6FFF	GPIO Port C	634

Table 2-4. Memory Map (continued)

Start	End	Description	For details, see page ...
0x4000.7000	0x4000.7FFF	GPIO Port D	634
0x4000.8000	0x4000.8FFF	SSI0	932
0x4000.9000	0x4000.9FFF	SSI1	932
0x4000.A000	0x4000.AFFF	SSI2	932
0x4000.B000	0x4000.BFFF	SSI3	932
0x4000.C000	0x4000.CFFF	UART0	868
0x4000.D000	0x4000.DFFF	UART1	868
0x4000.E000	0x4000.EFFF	UART2	868
0x4000.F000	0x4000.FFFF	UART3	868
0x4001.0000	0x4001.0FFF	UART4	868
0x4001.1000	0x4001.1FFF	UART5	868
0x4001.2000	0x4001.2FFF	UART6	868
0x4001.3000	0x4001.3FFF	UART7	868
0x4001.4000	0x4001.FFFF	Reserved	-
Peripherals			
0x4002.0000	0x4002.0FFF	I ² C 0	980
0x4002.1000	0x4002.1FFF	I ² C 1	980
0x4002.2000	0x4002.2FFF	I ² C 2	980
0x4002.3000	0x4002.3FFF	I ² C 3	980
0x4002.4000	0x4002.4FFF	GPIO Port E	634
0x4002.5000	0x4002.5FFF	GPIO Port F	634
0x4002.6000	0x4002.6FFF	GPIO Port G	634
0x4002.7000	0x4002.7FFF	Reserved	-
0x4002.8000	0x4002.8FFF	PWM 0	1202
0x4002.9000	0x4002.9FFF	PWM 1	1202
0x4002.A000	0x4002.BFFF	Reserved	-
0x4002.C000	0x4002.CFFF	QEI0	1273
0x4002.D000	0x4002.DFFF	QEI1	1273
0x4002.E000	0x4002.FFFF	Reserved	-
0x4003.0000	0x4003.0FFF	16/32-bit Timer 0	699
0x4003.1000	0x4003.1FFF	16/32-bit Timer 1	699
0x4003.2000	0x4003.2FFF	16/32-bit Timer 2	699
0x4003.3000	0x4003.3FFF	16/32-bit Timer 3	699
0x4003.4000	0x4003.4FFF	16/32-bit Timer 4	699
0x4003.5000	0x4003.5FFF	16/32-bit Timer 5	699
0x4003.6000	0x4003.6FFF	32/64-bit Timer 0	699
0x4003.7000	0x4003.7FFF	32/64-bit Timer 1	699
0x4003.8000	0x4003.8FFF	ADC0	792
0x4003.9000	0x4003.9FFF	ADC1	792
0x4003.A000	0x4003.BFFF	Reserved	-
0x4003.C000	0x4003.CFFF	Analog Comparators	1174

Table 2-4. Memory Map (continued)

Start	End	Description	For details, see page ...
0x4003.D000	0x4003.FFFF	Reserved	-
0x4004.0000	0x4004.0FFF	CAN0 Controller	1028
0x4004.1000	0x4004.1FFF	CAN1 Controller	1028
0x4004.2000	0x4004.BFFF	Reserved	-
0x4004.C000	0x4004.CFFF	32/64-bit Timer 2	699
0x4004.D000	0x4004.DFFF	32/64-bit Timer 3	699
0x4004.E000	0x4004.EFFF	32/64-bit Timer 4	699
0x4004.F000	0x4004.FFFF	32/64-bit Timer 5	699
0x4005.0000	0x4005.0FFF	USB	1080
0x4005.1000	0x4005.7FFF	Reserved	-
0x4005.8000	0x4005.8FFF	GPIO Port A (AHB aperture)	634
0x4005.9000	0x4005.9FFF	GPIO Port B (AHB aperture)	634
0x4005.A000	0x4005.AFFF	GPIO Port C (AHB aperture)	634
0x4005.B000	0x4005.BFFF	GPIO Port D (AHB aperture)	634
0x4005.C000	0x4005.CFFF	GPIO Port E (AHB aperture)	634
0x4005.D000	0x4005.DFFF	GPIO Port F (AHB aperture)	634
0x4005.E000	0x4005.EFFF	GPIO Port G (AHB aperture)	634
0x4005.F000	0x400A.EFFF	Reserved	-
0x400A.F000	0x400A.FFFF	EEPROM and Key Locker	534
0x400B.0000	0x400B.FFFF	Reserved	-
0x400C.0000	0x400C.0FFF	I ² C 4	980
0x400C.1000	0x400C.1FFF	I ² C 5	980
0x400C.2000	0x400F.8FFF	Reserved	-
0x400F.9000	0x400F.9FFF	System Exception Module	493
0x400F.A000	0x400F.CFFF	Reserved	-
0x400F.D000	0x400F.DFFF	Flash memory control	516
0x400F.E000	0x400F.EFFF	System control	235
0x400F.F000	0x400F.FFFF	μDMA	580
0x4010.0000	0x41FF.FFFF	Reserved	-
0x4200.0000	0x43FF.FFFF	Bit-banded alias of 0x4000.0000 through 0x400F.FFFF	-
0x4400.0000	0xDFFF.FFFF	Reserved	-
Private Peripheral Bus			
0xE000.0000	0xE000.0FFF	Instrumentation Trace Macrocell (ITM)	72
0xE000.1000	0xE000.1FFF	Data Watchpoint and Trace (DWT)	72
0xE000.2000	0xE000.2FFF	Flash Patch and Breakpoint (FPB)	72
0xE000.3000	0xE000.DFFF	Reserved	-
0xE000.E000	0xE000.EFFF	Cortex-M4F Peripherals (SysTick, NVIC, MPU, FPU and SCB)	135
0xE000.F000	0xE003.FFFF	Reserved	-
0xE004.0000	0xE004.0FFF	Trace Port Interface Unit (TPIU)	73
0xE004.1000	0xE004.1FFF	Embedded Trace Macrocell (ETM)	72
0xE004.2000	0xFFFF.FFFF	Reserved	-

2.4.1 Memory Regions, Types and Attributes

The memory map and the programming of the MPU split the memory map into regions. Each region has a defined memory type, and some regions have additional memory attributes. The memory type and attributes determine the behavior of accesses to the region.

The memory types are:

- Normal: The processor can re-order transactions for efficiency and perform speculative reads.
- Device: The processor preserves transaction order relative to other transactions to Device or Strongly Ordered memory.
- Strongly Ordered: The processor preserves transaction order relative to all other transactions.

The different ordering requirements for Device and Strongly Ordered memory mean that the memory system can buffer a write to Device memory but must not buffer a write to Strongly Ordered memory.

An additional memory attribute is Execute Never (XN), which means the processor prevents instruction accesses. A fault exception is generated only on execution of an instruction executed from an XN region.

2.4.2 Memory System Ordering of Memory Accesses

For most memory accesses caused by explicit memory access instructions, the memory system does not guarantee that the order in which the accesses complete matches the program order of the instructions, providing the order does not affect the behavior of the instruction sequence. Normally, if correct program execution depends on two memory accesses completing in program order, software must insert a memory barrier instruction between the memory access instructions (see “Software Ordering of Memory Accesses” on page 97).

However, the memory system does guarantee ordering of accesses to Device and Strongly Ordered memory. For two memory access instructions A1 and A2, if both A1 and A2 are accesses to either Device or Strongly Ordered memory, and if A1 occurs before A2 in program order, A1 is always observed before A2.

2.4.3 Behavior of Memory Accesses

Table 2-5 on page 96 shows the behavior of accesses to each region in the memory map. See “Memory Regions, Types and Attributes” on page 96 for more information on memory types and the XN attribute. Stellaris devices may have reserved memory areas within the address ranges shown below (refer to Table 2-4 on page 93 for more information).

Table 2-5. Memory Access Behavior

Address Range	Memory Region	Memory Type	Execute Never (XN)	Description
0x0000.0000 - 0x1FFF.FFFF	Code	Normal	-	This executable region is for program code. Data can also be stored here.
0x2000.0000 - 0x3FFF.FFFF	SRAM	Normal	-	This executable region is for data. Code can also be stored here. This region includes bit band and bit band alias areas (see Table 2-6 on page 98).
0x4000.0000 - 0x5FFF.FFFF	Peripheral	Device	XN	This region includes bit band and bit band alias areas (see Table 2-7 on page 99).
0x6000.0000 - 0x9FFF.FFFF	External RAM	Normal	-	This executable region is for data.

Table 2-5. Memory Access Behavior (continued)

Address Range	Memory Region	Memory Type	Execute Never (XN)	Description
0xA000.0000 - 0xDFFF.FFFF	External device	Device	XN	This region is for external device memory.
0xE000.0000- 0xE00F.FFFF	Private peripheral bus	Strongly Ordered	XN	This region includes the NVIC, system timer, and system control block.
0xE010.0000- 0xFFFF.FFFF	Reserved	-	-	-

The Code, SRAM, and external RAM regions can hold programs. However, it is recommended that programs always use the Code region because the Cortex-M4F has separate buses that can perform instruction fetches and data accesses simultaneously.

The MPU can override the default memory access behavior described in this section. For more information, see “Memory Protection Unit (MPU)” on page 126.

The Cortex-M4F prefetches instructions ahead of execution and speculatively prefetches from branch target addresses.

2.4.4 Software Ordering of Memory Accesses

The order of instructions in the program flow does not always guarantee the order of the corresponding memory transactions for the following reasons:

- The processor can reorder some memory accesses to improve efficiency, providing this does not affect the behavior of the instruction sequence.
- The processor has multiple bus interfaces.
- Memory or devices in the memory map have different wait states.
- Some memory accesses are buffered or speculative.

“Memory System Ordering of Memory Accesses” on page 96 describes the cases where the memory system guarantees the order of memory accesses. Otherwise, if the order of memory accesses is critical, software must include memory barrier instructions to force that ordering. The Cortex-M4F has the following memory barrier instructions:

- The Data Memory Barrier (DMB) instruction ensures that outstanding memory transactions complete before subsequent memory transactions.
- The Data Synchronization Barrier (DSB) instruction ensures that outstanding memory transactions complete before subsequent instructions execute.
- The Instruction Synchronization Barrier (ISB) instruction ensures that the effect of all completed memory transactions is recognizable by subsequent instructions.

Memory barrier instructions can be used in the following situations:

- MPU programming
 - If the MPU settings are changed and the change must be effective on the very next instruction, use a DSB instruction to ensure the effect of the MPU takes place immediately at the end of context switching.

- Use an `ISB` instruction to ensure the new MPU setting takes effect immediately after programming the MPU region or regions, if the MPU configuration code was accessed using a branch or call. If the MPU configuration code is entered using exception mechanisms, then an `ISB` instruction is not required.

- Vector table

If the program changes an entry in the vector table and then enables the corresponding exception, use a `DMB` instruction between the operations. The `DMB` instruction ensures that if the exception is taken immediately after being enabled, the processor uses the new exception vector.

- Self-modifying code

If a program contains self-modifying code, use an `ISB` instruction immediately after the code modification in the program. The `ISB` instruction ensures subsequent instruction execution uses the updated program.

- Memory map switching

If the system contains a memory map switching mechanism, use a `DSB` instruction after switching the memory map in the program. The `DSB` instruction ensures subsequent instruction execution uses the updated memory map.

- Dynamic exception priority change

When an exception priority has to change when the exception is pending or active, use `DSB` instructions after the change. The change then takes effect on completion of the `DSB` instruction.

Memory accesses to Strongly Ordered memory, such as the System Control Block, do not require the use of `DMB` instructions.

For more information on the memory barrier instructions, see the *Cortex™-M3/M4 Instruction Set Technical User's Manual*.

2.4.5 Bit-Banding

A bit-band region maps each word in a bit-band alias region to a single bit in the bit-band region. The bit-band regions occupy the lowest 1 MB of the SRAM and peripheral memory regions. Accesses to the 32-MB SRAM alias region map to the 1-MB SRAM bit-band region, as shown in Table 2-6 on page 98. Accesses to the 32-MB peripheral alias region map to the 1-MB peripheral bit-band region, as shown in Table 2-7 on page 99. For the specific address range of the bit-band regions, see Table 2-4 on page 93.

Note: A word access to the SRAM or the peripheral bit-band alias region maps to a single bit in the SRAM or peripheral bit-band region.

A word access to a bit band address results in a word access to the underlying memory, and similarly for halfword and byte accesses. This allows bit band accesses to match the access requirements of the underlying peripheral.

Table 2-6. SRAM Memory Bit-Banding Regions

Address Range	Memory Region	Instruction and Data Accesses
0x2000.0000 - 0x200F.FFFF	SRAM bit-band region	Direct accesses to this memory range behave as SRAM memory accesses, but this region is also bit addressable through bit-band alias.

Table 2-6. SRAM Memory Bit-Banding Regions (continued)

Address Range	Memory Region	Instruction and Data Accesses
0x2200.0000 - 0x23FF.FFFF	SRAM bit-band alias	Data accesses to this region are remapped to bit band region. A write operation is performed as read-modify-write. Instruction accesses are not remapped.

Table 2-7. Peripheral Memory Bit-Banding Regions

Address Range	Memory Region	Instruction and Data Accesses
0x4000.0000 - 0x400F.FFFF	Peripheral bit-band region	Direct accesses to this memory range behave as peripheral memory accesses, but this region is also bit addressable through bit-band alias.
0x4200.0000 - 0x43FF.FFFF	Peripheral bit-band alias	Data accesses to this region are remapped to bit band region. A write operation is performed as read-modify-write. Instruction accesses are not permitted.

The following formula shows how the alias region maps onto the bit-band region:

$$\text{bit_word_offset} = (\text{byte_offset} \times 32) + (\text{bit_number} \times 4)$$

$$\text{bit_word_addr} = \text{bit_band_base} + \text{bit_word_offset}$$

where:

bit_word_offset

The position of the target bit in the bit-band memory region.

bit_word_addr

The address of the word in the alias memory region that maps to the targeted bit.

bit_band_base

The starting address of the alias region.

byte_offset

The number of the byte in the bit-band region that contains the targeted bit.

bit_number

The bit position, 0-7, of the targeted bit.

Figure 2-4 on page 100 shows examples of bit-band mapping between the SRAM bit-band alias region and the SRAM bit-band region:

- The alias word at 0x23FF.FFE0 maps to bit 0 of the bit-band byte at 0x200F.FFFF:

$$0x23FF.FFE0 = 0x2200.0000 + (0x000F.FFFF * 32) + (0 * 4)$$

- The alias word at 0x23FF.FFFC maps to bit 7 of the bit-band byte at 0x200F.FFFF:

$$0x23FF.FFFC = 0x2200.0000 + (0x000F.FFFF * 32) + (7 * 4)$$

- The alias word at 0x2200.0000 maps to bit 0 of the bit-band byte at 0x2000.0000:

$$0x2200.0000 = 0x2200.0000 + (0 * 32) + (0 * 4)$$

- The alias word at 0x2200.001C maps to bit 7 of the bit-band byte at 0x2000.0000:

$$0x2200.001C = 0x2200.0000 + (0 * 32) + (7 * 4)$$

Figure 2-4. Bit-Band Mapping

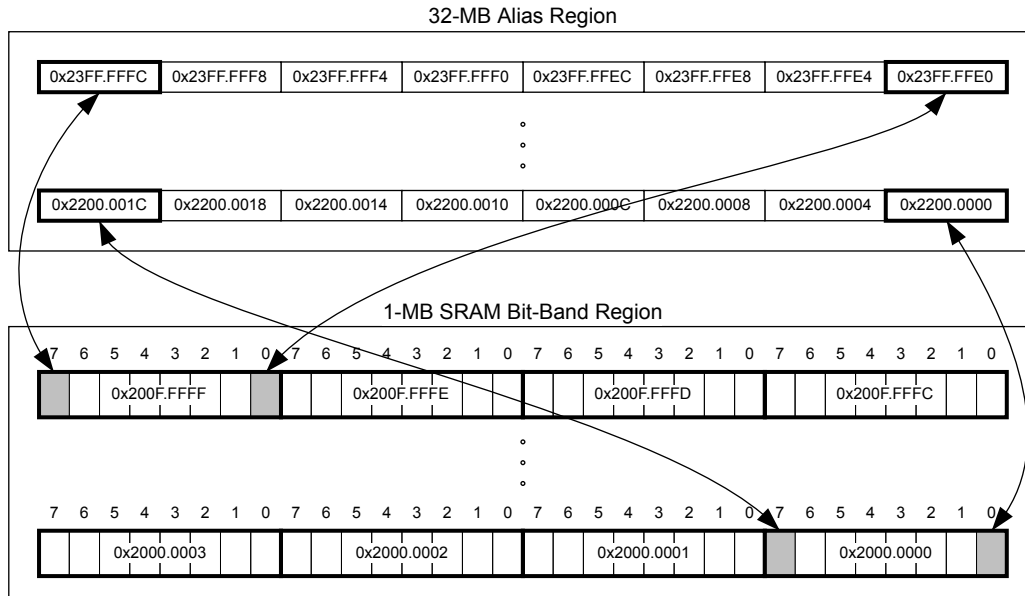

2.4.5.1 Directly Accessing an Alias Region

Writing to a word in the alias region updates a single bit in the bit-band region.

Bit 0 of the value written to a word in the alias region determines the value written to the targeted bit in the bit-band region. Writing a value with bit 0 set writes a 1 to the bit-band bit, and writing a value with bit 0 clear writes a 0 to the bit-band bit.

Bits 31:1 of the alias word have no effect on the bit-band bit. Writing 0x01 has the same effect as writing 0xFF. Writing 0x00 has the same effect as writing 0x0E.

When reading a word in the alias region, 0x0000.0000 indicates that the targeted bit in the bit-band region is clear and 0x0000.0001 indicates that the targeted bit in the bit-band region is set.

2.4.5.2 Directly Accessing a Bit-Band Region

“Behavior of Memory Accesses” on page 96 describes the behavior of direct byte, halfword, or word accesses to the bit-band regions.

2.4.6 Data Storage

The processor views memory as a linear collection of bytes numbered in ascending order from zero. For example, bytes 0-3 hold the first stored word, and bytes 4-7 hold the second stored word. Data is stored in little-endian format, with the least-significant byte (lsbyte) of a word stored at the lowest-numbered byte, and the most-significant byte (msbyte) stored at the highest-numbered byte. Figure 2-5 on page 101 illustrates how data is stored.

Figure 2-5. Data Storage

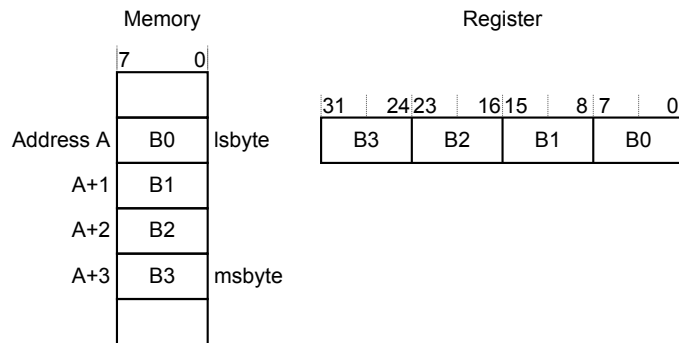

2.4.7 Synchronization Primitives

The Cortex-M4F instruction set includes pairs of synchronization primitives which provide a non-blocking mechanism that a thread or process can use to obtain exclusive access to a memory location. Software can use these primitives to perform a guaranteed read-modify-write memory update sequence or for a semaphore mechanism.

A pair of synchronization primitives consists of:

- A Load-Exclusive instruction, which is used to read the value of a memory location and requests exclusive access to that location.
- A Store-Exclusive instruction, which is used to attempt to write to the same memory location and returns a status bit to a register. If this status bit is clear, it indicates that the thread or process gained exclusive access to the memory and the write succeeds; if this status bit is set, it indicates that the thread or process did not gain exclusive access to the memory and no write was performed.

The pairs of Load-Exclusive and Store-Exclusive instructions are:

- The word instructions `LDREX` and `STREX`
- The halfword instructions `LDREXH` and `STREXH`
- The byte instructions `LDREXB` and `STREXB`

Software must use a Load-Exclusive instruction with the corresponding Store-Exclusive instruction.

To perform an exclusive read-modify-write of a memory location, software must:

1. Use a Load-Exclusive instruction to read the value of the location.
2. Modify the value, as required.
3. Use a Store-Exclusive instruction to attempt to write the new value back to the memory location.
4. Test the returned status bit.

If the status bit is clear, the read-modify-write completed successfully. If the status bit is set, no write was performed, which indicates that the value returned at step 1 might be out of date. The software must retry the entire read-modify-write sequence.

Software can use the synchronization primitives to implement a semaphore as follows:

1. Use a Load-Exclusive instruction to read from the semaphore address to check whether the semaphore is free.
2. If the semaphore is free, use a Store-Exclusive to write the claim value to the semaphore address.
3. If the returned status bit from step 2 indicates that the Store-Exclusive succeeded, then the software has claimed the semaphore. However, if the Store-Exclusive failed, another process might have claimed the semaphore after the software performed step 1.

The Cortex-M4F includes an exclusive access monitor that tags the fact that the processor has executed a Load-Exclusive instruction. The processor removes its exclusive access tag if:

- It executes a `CLREX` instruction.
- It executes a Store-Exclusive instruction, regardless of whether the write succeeds.
- An exception occurs, which means the processor can resolve semaphore conflicts between different threads.

For more information about the synchronization primitive instructions, see the *Cortex™-M3/M4 Instruction Set Technical User's Manual*.

2.5 Exception Model

The ARM Cortex-M4F processor and the Nested Vectored Interrupt Controller (NVIC) prioritize and handle all exceptions in Handler Mode. The processor state is automatically stored to the stack on an exception and automatically restored from the stack at the end of the Interrupt Service Routine (ISR). The vector is fetched in parallel to the state saving, enabling efficient interrupt entry. The processor supports tail-chaining, which enables back-to-back interrupts to be performed without the overhead of state saving and restoration.

Table 2-8 on page 104 lists all exception types. Software can set eight priority levels on seven of these exceptions (system handlers) as well as on 80 interrupts (listed in Table 2-9 on page 105).

Priorities on the system handlers are set with the NVIC **System Handler Priority n (SYSPRI_n)** registers. Interrupts are enabled through the NVIC **Interrupt Set Enable n (EN_n)** register and prioritized with the NVIC **Interrupt Priority n (PRI_n)** registers. Priorities can be grouped by splitting priority levels into preemption priorities and subpriorities. All the interrupt registers are described in “Nested Vectored Interrupt Controller (NVIC)” on page 125.

Internally, the highest user-programmable priority (0) is treated as fourth priority, after a Reset, Non-Maskable Interrupt (NMI), and a Hard Fault, in that order. Note that 0 is the default priority for all the programmable priorities.

Important: After a write to clear an interrupt source, it may take several processor cycles for the NVIC to see the interrupt source de-assert. Thus if the interrupt clear is done as the last action in an interrupt handler, it is possible for the interrupt handler to complete while the NVIC sees the interrupt as still asserted, causing the interrupt handler to be re-entered errantly. This situation can be avoided by either clearing the interrupt source at the beginning of the interrupt handler or by performing a read or write after the write to clear the interrupt source (and flush the write buffer).

See “Nested Vectored Interrupt Controller (NVIC)” on page 125 for more information on exceptions and interrupts.

2.5.1 Exception States

Each exception is in one of the following states:

- **Inactive.** The exception is not active and not pending.
- **Pending.** The exception is waiting to be serviced by the processor. An interrupt request from a peripheral or from software can change the state of the corresponding interrupt to pending.
- **Active.** An exception that is being serviced by the processor but has not completed.
Note: An exception handler can interrupt the execution of another exception handler. In this case, both exceptions are in the active state.
- **Active and Pending.** The exception is being serviced by the processor, and there is a pending exception from the same source.

2.5.2 Exception Types

The exception types are:

- **Reset.** Reset is invoked on power up or a warm reset. The exception model treats reset as a special form of exception. When reset is asserted, the operation of the processor stops, potentially at any point in an instruction. When reset is deasserted, execution restarts from the address provided by the reset entry in the vector table. Execution restarts as privileged execution in Thread mode.
- **NMI.** A non-maskable Interrupt (NMI) can be signaled using the NMI signal or triggered by software using the **Interrupt Control and State (INTCTRL)** register. This exception has the highest priority other than reset. NMI is permanently enabled and has a fixed priority of -2. NMIs cannot be masked or prevented from activation by any other exception or preempted by any exception other than reset.
- **Hard Fault.** A hard fault is an exception that occurs because of an error during exception processing, or because an exception cannot be managed by any other exception mechanism. Hard faults have a fixed priority of -1, meaning they have higher priority than any exception with configurable priority.
- **Memory Management Fault.** A memory management fault is an exception that occurs because of a memory protection related fault, including access violation and no match. The MPU or the fixed memory protection constraints determine this fault, for both instruction and data memory transactions. This fault is used to abort instruction accesses to Execute Never (XN) memory regions, even if the MPU is disabled.
- **Bus Fault.** A bus fault is an exception that occurs because of a memory-related fault for an instruction or data memory transaction such as a prefetch fault or a memory access fault. This fault can be enabled or disabled.
- **Usage Fault.** A usage fault is an exception that occurs because of a fault related to instruction execution, such as:
 - An undefined instruction
 - An illegal unaligned access
 - Invalid state on instruction execution

- An error on exception return

An unaligned address on a word or halfword memory access or division by zero can cause a usage fault when the core is properly configured.

- **SVC**Call. A supervisor call (SVC) is an exception that is triggered by the SVC instruction. In an OS environment, applications can use SVC instructions to access OS kernel functions and device drivers.
- **Debug Monitor**. This exception is caused by the debug monitor (when not halting). This exception is only active when enabled. This exception does not activate if it is a lower priority than the current activation.
- **PendSV**. PendSV is a pendable, interrupt-driven request for system-level service. In an OS environment, use PendSV for context switching when no other exception is active. PendSV is triggered using the **Interrupt Control and State (INTCTRL)** register.
- **SysTick**. A SysTick exception is an exception that the system timer generates when it reaches zero when it is enabled to generate an interrupt. Software can also generate a SysTick exception using the **Interrupt Control and State (INTCTRL)** register. In an OS environment, the processor can use this exception as system tick.
- **Interrupt (IRQ)**. An interrupt, or IRQ, is an exception signaled by a peripheral or generated by a software request and fed through the NVIC (prioritized). All interrupts are asynchronous to instruction execution. In the system, peripherals use interrupts to communicate with the processor. Table 2-9 on page 105 lists the interrupts on the LM4F231H5QR controller.

For an asynchronous exception, other than reset, the processor can execute another instruction between when the exception is triggered and when the processor enters the exception handler.

Privileged software can disable the exceptions that Table 2-8 on page 104 shows as having configurable priority (see the **SYSHNDCTRL** register on page 174 and the **DIS0** register on page 145).

For more information about hard faults, memory management faults, bus faults, and usage faults, see “Fault Handling” on page 112.

Table 2-8. Exception Types

Exception Type	Vector Number	Priority ^a	Vector Address or Offset ^b	Activation
-	0	-	0x0000.0000	Stack top is loaded from the first entry of the vector table on reset.
Reset	1	-3 (highest)	0x0000.0004	Asynchronous
Non-Maskable Interrupt (NMI)	2	-2	0x0000.0008	Asynchronous
Hard Fault	3	-1	0x0000.000C	-
Memory Management	4	programmable ^c	0x0000.0010	Synchronous
Bus Fault	5	programmable ^c	0x0000.0014	Synchronous when precise and asynchronous when imprecise
Usage Fault	6	programmable ^c	0x0000.0018	Synchronous
-	7-10	-	-	Reserved
SVCCall	11	programmable ^c	0x0000.002C	Synchronous
Debug Monitor	12	programmable ^c	0x0000.0030	Synchronous
-	13	-	-	Reserved

Table 2-8. Exception Types (continued)

Exception Type	Vector Number	Priority ^a	Vector Address or Offset ^b	Activation
PendSV	14	programmable ^c	0x0000.0038	Asynchronous
SysTick	15	programmable ^c	0x0000.003C	Asynchronous
Interrupts	16 and above	programmable ^d	0x0000.0040 and above	Asynchronous

a. 0 is the default priority for all the programmable priorities.

b. See "Vector Table" on page 107.

c. See **SYSPRI1** on page 171.

d. See **PRIn** registers on page 153.

Table 2-9. Interrupts

Vector Number	Interrupt Number (Bit in Interrupt Registers)	Vector Address or Offset	Description
0-15	-	0x0000.0000 - 0x0000.003C	Processor exceptions
16	0	0x0000.0040	GPIO Port A
17	1	0x0000.0044	GPIO Port B
18	2	0x0000.0048	GPIO Port C
19	3	0x0000.004C	GPIO Port D
20	4	0x0000.0050	GPIO Port E
21	5	0x0000.0054	UART0
22	6	0x0000.0058	UART1
23	7	0x0000.005C	SSI0
24	8	0x0000.0060	I ² C0
25	9	0x0000.0064	PWM0 Fault
26	10	0x0000.0068	PWM0 Generator 0
27	11	0x0000.006C	PWM0 Generator 1
28	12	0x0000.0070	PWM0 Generator 2
29	13	0x0000.0074	QEI0
30	14	0x0000.0078	ADC0 Sequence 0
31	15	0x0000.007C	ADC0 Sequence 1
32	16	0x0000.0080	ADC0 Sequence 2
33	17	0x0000.0084	ADC0 Sequence 3
34	18	0x0000.0088	Watchdog Timers 0 and 1
35	19	0x0000.008C	16/32-Bit Timer 0A
36	20	0x0000.0090	16/32-Bit Timer 0B
37	21	0x0000.0094	16/32-Bit Timer 1A
38	22	0x0000.0098	16/32-Bit Timer 1B
39	23	0x0000.009C	16/32-Bit Timer 2A
40	24	0x0000.00A0	16/32-Bit Timer 2B
41	25	0x0000.00A4	Analog Comparator 0
42	26	0x0000.00A8	Analog Comparator 1
43	27	-	Reserved
44	28	0x0000.00B0	System Control

Table 2-9. Interrupts (continued)

Vector Number	Interrupt Number (Bit in Interrupt Registers)	Vector Address or Offset	Description
45	29	0x0000.00B4	Flash Memory Control and EEPROM Control
46	30	0x0000.00B8	GPIO Port F
47	31	0x0000.00BC	GPIO Port G
48	32	-	Reserved
49	33	0x0000.00C4	UART2
50	34	0x0000.00C8	SSI1
51	35	0x0000.00CC	16/32-Bit Timer 3A
52	36	0x0000.00D0	16/32-Bit Timer 3B
53	37	0x0000.00D4	I ² C1
54	38	0x0000.00D8	QEI1
55	39	0x0000.00DC	CAN0
56	40	0x0000.00E0	CAN1
57-59	41-43	-	Reserved
60	44	0x0000.00F0	USB
61	45	0x0000.00F4	PWM Generator 3
62	46	0x0000.00F8	μDMA Software
63	47	0x0000.00FC	μDMA Error
64	48	0x0000.0100	ADC1 Sequence 0
65	49	0x0000.0104	ADC1 Sequence 1
66	50	0x0000.0108	ADC1 Sequence 2
67	51	0x0000.010C	ADC1 Sequence 3
68-72	52-56	-	Reserved
73	57	0x0000.0124	SSI2
74	58	0x0000.0128	SSI3
75	59	0x0000.012C	UART3
76	60	0x0000.0130	UART4
77	61	0x0000.0134	UART5
78	62	0x0000.0138	UART6
79	63	0x0000.013C	UART7
80-83	64-67	0x0000.0140 - 0x0000.014C	Reserved
84	68	0x0000.0150	I ² C2
85	69	0x0000.0154	I ² C3
86	70	0x0000.0158	16/32-Bit Timer 4A
87	71	0x0000.015C	16/32-Bit Timer 4B
88-107	72-91	0x0000.0160 - 0x0000.01AC	Reserved
108	92	0x0000.01B0	16/32-Bit Timer 5A
109	93	0x0000.01B4	16/32-Bit Timer 5B
110	94	0x0000.01B8	32/64-Bit Timer 0A
111	95	0x0000.01BC	32/64-Bit Timer 0B
112	96	0x0000.01C0	32/64-Bit Timer 1A

Table 2-9. Interrupts (continued)

Vector Number	Interrupt Number (Bit in Interrupt Registers)	Vector Address or Offset	Description
113	97	0x0000.01C4	32/64-Bit Timer 1B
114	98	0x0000.01C8	32/64-Bit Timer 2A
115	99	0x0000.01CC	32/64-Bit Timer 2B
116	100	0x0000.01D0	32/64-Bit Timer 3A
117	101	0x0000.01D4	32/64-Bit Timer 3B
118	102	0x0000.01D8	32/64-Bit Timer 4A
119	103	0x0000.01DC	32/64-Bit Timer 4B
120	104	0x0000.01E0	32/64-Bit Timer 5A
121	105	0x0000.01E4	32/64-Bit Timer 5B
122	106	0x0000.01E8	System Exception (imprecise)
123-124	107-108	-	Reserved
125	109	0x0000.01F4	I ² C4
126	110	0x0000.01F8	I ² C5
127-149	111-133	-	Reserved
150	134	0x0000.0258	PWM1 Generator 0
151	135	0x0000.025C	PWM1 Generator 1
152	136	0x0000.0260	PWM1 Generator 2
153	137	0x0000.0264	PWM1 Generator 3
154	138	0x0000.0268	PWM1 Fault

2.5.3 Exception Handlers

The processor handles exceptions using:

- **Interrupt Service Routines (ISRs).** Interrupts (IRQx) are the exceptions handled by ISRs.
- **Fault Handlers.** Hard fault, memory management fault, usage fault, and bus fault are fault exceptions handled by the fault handlers.
- **System Handlers.** NMI, PendSV, SVCcall, SysTick, and the fault exceptions are all system exceptions that are handled by system handlers.

2.5.4 Vector Table

The vector table contains the reset value of the stack pointer and the start addresses, also called exception vectors, for all exception handlers. The vector table is constructed using the vector address or offset shown in Table 2-8 on page 104. Figure 2-6 on page 108 shows the order of the exception vectors in the vector table. The least-significant bit of each vector must be 1, indicating that the exception handler is Thumb code

Figure 2-6. Vector Table

Exception number	IRQ number	Offset	Vector
154	138	0x0268	IRQ131
.	.	.	.
.	.	.	.
.	.	.	.
18	2	0x004C	IRQ2
17	1	0x0048	IRQ1
16	0	0x0044	IRQ0
15	-1	0x0040	Systick
14	-2	0x003C	PendSV
13		0x0038	Reserved
12			Reserved for Debug
11	-5	0x002C	SVCcall
10			Reserved
9			
8			
7			
6	-10	0x0018	Usage fault
5	-11	0x0014	Bus fault
4	-12	0x0010	Memory management fault
3	-13	0x000C	Hard fault
2	-14	0x0008	NMI
1		0x0004	Reset
		0x0000	Initial SP value

On system reset, the vector table is fixed at address 0x0000.0000. Privileged software can write to the **Vector Table Offset (VTABLE)** register to relocate the vector table start address to a different memory location, in the range 0x0000.0400 to 0x3FFF.FC00 (see “Vector Table” on page 107). Note that when configuring the **VTABLE** register, the offset must be aligned on a 1024-byte boundary.

2.5.5 Exception Priorities

As Table 2-8 on page 104 shows, all exceptions have an associated priority, with a lower priority value indicating a higher priority and configurable priorities for all exceptions except Reset, Hard fault, and NMI. If software does not configure any priorities, then all exceptions with a configurable priority have a priority of 0. For information about configuring exception priorities, see page 171 and page 153.

Note: Configurable priority values for the Stellaris implementation are in the range 0-7. This means that the Reset, Hard fault, and NMI exceptions, with fixed negative priority values, always have higher priority than any other exception.

For example, assigning a higher priority value to IRQ[0] and a lower priority value to IRQ[1] means that IRQ[1] has higher priority than IRQ[0]. If both IRQ[1] and IRQ[0] are asserted, IRQ[1] is processed before IRQ[0].

If multiple pending exceptions have the same priority, the pending exception with the lowest exception number takes precedence. For example, if both IRQ[0] and IRQ[1] are pending and have the same priority, then IRQ[0] is processed before IRQ[1].

When the processor is executing an exception handler, the exception handler is preempted if a higher priority exception occurs. If an exception occurs with the same priority as the exception being handled, the handler is not preempted, irrespective of the exception number. However, the status of the new interrupt changes to pending.

2.5.6 Interrupt Priority Grouping

To increase priority control in systems with interrupts, the NVIC supports priority grouping. This grouping divides each interrupt priority register entry into two fields:

- An upper field that defines the group priority
- A lower field that defines a subpriority within the group

Only the group priority determines preemption of interrupt exceptions. When the processor is executing an interrupt exception handler, another interrupt with the same group priority as the interrupt being handled does not preempt the handler.

If multiple pending interrupts have the same group priority, the subpriority field determines the order in which they are processed. If multiple pending interrupts have the same group priority and subpriority, the interrupt with the lowest IRQ number is processed first.

For information about splitting the interrupt priority fields into group priority and subpriority, see page 165.

2.5.7 Exception Entry and Return

Descriptions of exception handling use the following terms:

- **Preemption.** When the processor is executing an exception handler, an exception can preempt the exception handler if its priority is higher than the priority of the exception being handled. See “Interrupt Priority Grouping” on page 109 for more information about preemption by an interrupt. When one exception preempts another, the exceptions are called nested exceptions. See “Exception Entry” on page 110 for more information.
- **Return.** Return occurs when the exception handler is completed, and there is no pending exception with sufficient priority to be serviced and the completed exception handler was not handling a late-arriving exception. The processor pops the stack and restores the processor state to the state it had before the interrupt occurred. See “Exception Return” on page 111 for more information.
- **Tail-Chaining.** This mechanism speeds up exception servicing. On completion of an exception handler, if there is a pending exception that meets the requirements for exception entry, the stack pop is skipped and control transfers to the new exception handler.
- **Late-Arriving.** This mechanism speeds up preemption. If a higher priority exception occurs during state saving for a previous exception, the processor switches to handle the higher priority exception and initiates the vector fetch for that exception. State saving is not affected by late arrival because the state saved is the same for both exceptions. Therefore, the state saving continues uninterrupted. The processor can accept a late arriving exception until the first instruction of the exception handler of the original exception enters the execute stage of the processor. On

return from the exception handler of the late-arriving exception, the normal tail-chaining rules apply.

2.5.7.1 Exception Entry

Exception entry occurs when there is a pending exception with sufficient priority and either the processor is in Thread mode or the new exception is of higher priority than the exception being handled, in which case the new exception preempts the original exception.

When one exception preempts another, the exceptions are nested.

Sufficient priority means the exception has more priority than any limits set by the mask registers (see **PRIMASK** on page 86, **FAULTMASK** on page 87, and **BASEPRI** on page 88). An exception with less priority than this is pending but is not handled by the processor.

When the processor takes an exception, unless the exception is a tail-chained or a late-arriving exception, the processor pushes information onto the current stack. This operation is referred to as *stacking* and the structure of eight data words is referred to as *stack frame*.

When using floating-point routines, the Cortex-M4F processor automatically stacks the architected floating-point state on exception entry. Figure 2-7 on page 111 shows the Cortex-M4F stack frame layout when floating-point state is preserved on the stack as the result of an interrupt or an exception.

Note: Where stack space for floating-point state is not allocated, the stack frame is the same as that of ARMv7-M implementations without an FPU. Figure 2-7 on page 111 shows this stack frame also.

Figure 2-7. Exception Stack Frame

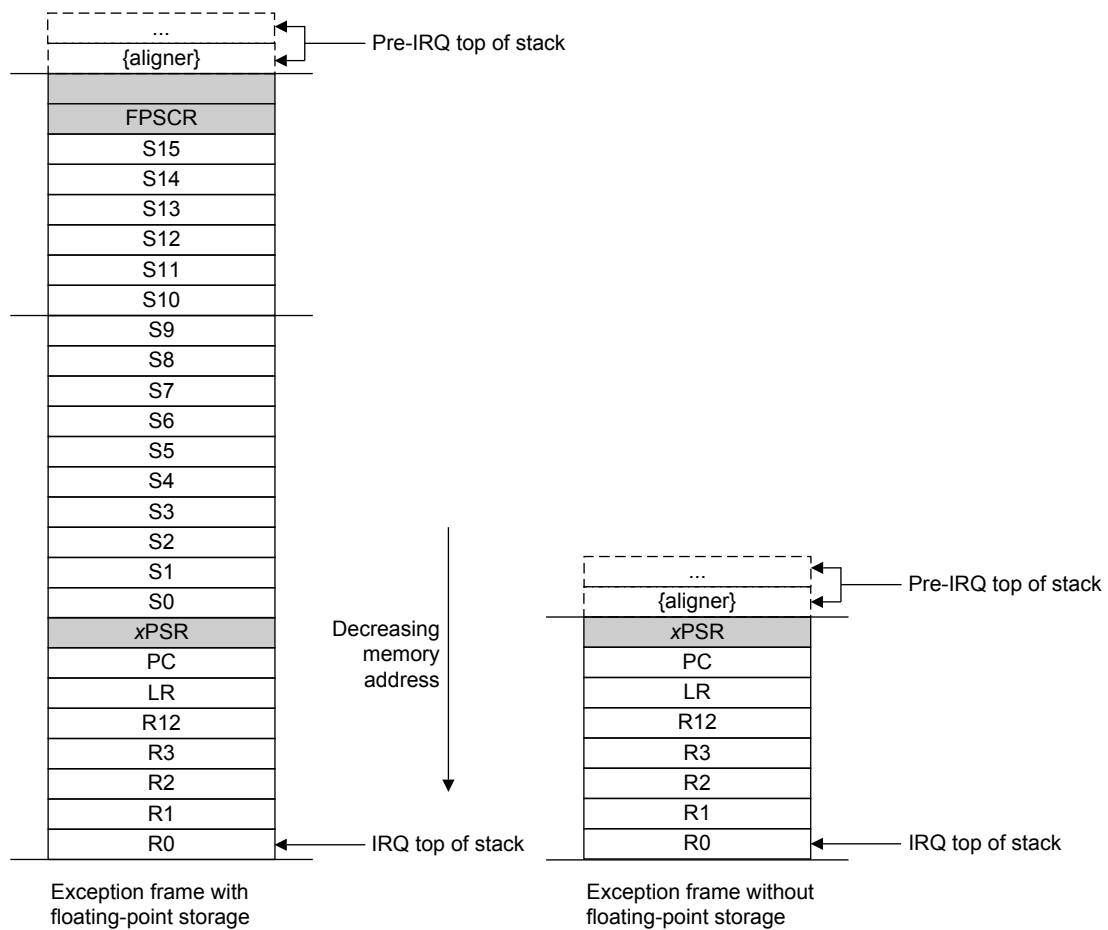

Immediately after stacking, the stack pointer indicates the lowest address in the stack frame.

The stack frame includes the return address, which is the address of the next instruction in the interrupted program. This value is restored to the **PC** at exception return so that the interrupted program resumes.

In parallel to the stacking operation, the processor performs a vector fetch that reads the exception handler start address from the vector table. When stacking is complete, the processor starts executing the exception handler. At the same time, the processor writes an **EXC_RETURN** value to the **LR**, indicating which stack pointer corresponds to the stack frame and what operation mode the processor was in before the entry occurred.

If no higher-priority exception occurs during exception entry, the processor starts executing the exception handler and automatically changes the status of the corresponding pending interrupt to active.

If another higher-priority exception occurs during exception entry, known as late arrival, the processor starts executing the exception handler for this exception and does not change the pending status of the earlier exception.

2.5.7.2 Exception Return

Exception return occurs when the processor is in Handler mode and executes one of the following instructions to load the **EXC_RETURN** value into the **PC**:

- An `LDM` or `POP` instruction that loads the **PC**
- A `BX` instruction using any register
- An `LDR` instruction with the **PC** as the destination

`EXC_RETURN` is the value loaded into the **LR** on exception entry. The exception mechanism relies on this value to detect when the processor has completed an exception handler. The lowest five bits of this value provide information on the return stack and processor mode. Table 2-10 on page 112 shows the `EXC_RETURN` values with a description of the exception return behavior.

`EXC_RETURN` bits 31:5 are all set. When this value is loaded into the **PC**, it indicates to the processor that the exception is complete, and the processor initiates the appropriate exception return sequence.

Table 2-10. Exception Return Behavior

<code>EXC_RETURN</code> [31:0]	Description
0xFFFF.FFE0	Reserved
0xFFFF.FFE1	Return to Handler mode. Exception return uses floating-point state from MSP . Execution uses MSP after return.
0xFFFF.FFE2 - 0xFFFF.FFE8	Reserved
0xFFFF.FFE9	Return to Thread mode. Exception return uses floating-point state from MSP . Execution uses MSP after return.
0xFFFF.FFEA - 0xFFFF.FFEC	Reserved
0xFFFF.FFED	Return to Thread mode. Exception return uses floating-point state from PSP . Execution uses PSP after return.
0xFFFF.FFEE - 0xFFFF.FFF0	Reserved
0xFFFF.FFF1	Return to Handler mode. Exception return uses non-floating-point state from MSP . Execution uses MSP after return.
0xFFFF.FFF2 - 0xFFFF.FFF8	Reserved
0xFFFF.FFF9	Return to Thread mode. Exception return uses non-floating-point state from MSP . Execution uses MSP after return.
0xFFFF.FFFA - 0xFFFF.FFFC	Reserved
0xFFFF.FFFD	Return to Thread mode. Exception return uses non-floating-point state from PSP . Execution uses PSP after return.
0xFFFF.FFFE - 0xFFFF.FFFF	Reserved

2.6 Fault Handling

Faults are a subset of the exceptions (see “Exception Model” on page 102). The following conditions generate a fault:

- A bus error on an instruction fetch or vector table load or a data access.

- An internally detected error such as an undefined instruction or an attempt to change state with a BX instruction.
- Attempting to execute an instruction from a memory region marked as Non-Executable (XN).
- An MPU fault because of a privilege violation or an attempt to access an unmanaged region.

2.6.1 Fault Types

Table 2-11 on page 113 shows the types of fault, the handler used for the fault, the corresponding fault status register, and the register bit that indicates the fault has occurred. See page 178 for more information about the fault status registers.

Table 2-11. Faults

Fault	Handler	Fault Status Register	Bit Name
Bus error on a vector read	Hard fault	Hard Fault Status (HFAULTSTAT)	VECT
Fault escalated to a hard fault	Hard fault	Hard Fault Status (HFAULTSTAT)	FORCED
MPU or default memory mismatch on instruction access	Memory management fault	Memory Management Fault Status (MFAULTSTAT)	IERR ^a
MPU or default memory mismatch on data access	Memory management fault	Memory Management Fault Status (MFAULTSTAT)	DERR
MPU or default memory mismatch on exception stacking	Memory management fault	Memory Management Fault Status (MFAULTSTAT)	MSTKE
MPU or default memory mismatch on exception unstacking	Memory management fault	Memory Management Fault Status (MFAULTSTAT)	MUSTKE
MPU or default memory mismatch during lazy floating-point state preservation	Memory management fault	Memory Management Fault Status (MFAULTSTAT)	MLSPERR
Bus error during exception stacking	Bus fault	Bus Fault Status (BFAULTSTAT)	BSTKE
Bus error during exception unstacking	Bus fault	Bus Fault Status (BFAULTSTAT)	BUSTKE
Bus error during instruction prefetch	Bus fault	Bus Fault Status (BFAULTSTAT)	IBUS
Bus error during lazy floating-point state preservation	Bus fault	Bus Fault Status (BFAULTSTAT)	BLSPE
Precise data bus error	Bus fault	Bus Fault Status (BFAULTSTAT)	PRECISE
Imprecise data bus error	Bus fault	Bus Fault Status (BFAULTSTAT)	IMPRE
Attempt to access a coprocessor	Usage fault	Usage Fault Status (UFAULTSTAT)	NOCP
Undefined instruction	Usage fault	Usage Fault Status (UFAULTSTAT)	UNDEF
Attempt to enter an invalid instruction set state ^b	Usage fault	Usage Fault Status (UFAULTSTAT)	INVSTAT
Invalid EXC_RETURN value	Usage fault	Usage Fault Status (UFAULTSTAT)	INVPC
Illegal unaligned load or store	Usage fault	Usage Fault Status (UFAULTSTAT)	UNALIGN
Divide by 0	Usage fault	Usage Fault Status (UFAULTSTAT)	DIV0

a. Occurs on an access to an XN region even if the MPU is disabled.

b. Attempting to use an instruction set other than the Thumb instruction set, or returning to a non load-store-multiple instruction with ICI continuation.

2.6.2 Fault Escalation and Hard Faults

All fault exceptions except for hard fault have configurable exception priority (see **SYSPRI1** on page 171). Software can disable execution of the handlers for these faults (see **SYSHNDCTRL** on page 174).

Usually, the exception priority, together with the values of the exception mask registers, determines whether the processor enters the fault handler, and whether a fault handler can preempt another fault handler as described in “Exception Model” on page 102.

In some situations, a fault with configurable priority is treated as a hard fault. This process is called priority escalation, and the fault is described as *escalated to hard fault*. Escalation to hard fault occurs when:

- A fault handler causes the same kind of fault as the one it is servicing. This escalation to hard fault occurs because a fault handler cannot preempt itself because it must have the same priority as the current priority level.
- A fault handler causes a fault with the same or lower priority as the fault it is servicing. This situation happens because the handler for the new fault cannot preempt the currently executing fault handler.
- An exception handler causes a fault for which the priority is the same as or lower than the currently executing exception.
- A fault occurs and the handler for that fault is not enabled.

If a bus fault occurs during a stack push when entering a bus fault handler, the bus fault does not escalate to a hard fault. Thus if a corrupted stack causes a fault, the fault handler executes even though the stack push for the handler failed. The fault handler operates but the stack contents are corrupted.

Note: Only Reset and NMI can preempt the fixed priority hard fault. A hard fault can preempt any exception other than Reset, NMI, or another hard fault.

2.6.3 Fault Status Registers and Fault Address Registers

The fault status registers indicate the cause of a fault. For bus faults and memory management faults, the fault address register indicates the address accessed by the operation that caused the fault, as shown in Table 2-12 on page 114.

Table 2-12. Fault Status and Fault Address Registers

Handler	Status Register Name	Address Register Name	Register Description
Hard fault	Hard Fault Status (HFAULTSTAT)	-	page 184
Memory management fault	Memory Management Fault Status (MFAULTSTAT)	Memory Management Fault Address (MMADDR)	page 178 page 185
Bus fault	Bus Fault Status (BFAULTSTAT)	Bus Fault Address (FAULTADDR)	page 178 page 186
Usage fault	Usage Fault Status (UFAULTSTAT)	-	page 178

2.6.4 Lockup

The processor enters a lockup state if a hard fault occurs when executing the NMI or hard fault handlers. When the processor is in the lockup state, it does not execute any instructions. The processor remains in lockup state until it is reset, an NMI occurs, or it is halted by a debugger.

Note: If the lockup state occurs from the NMI handler, a subsequent NMI does not cause the processor to leave the lockup state.

2.7 Power Management

The Cortex-M4F processor sleep modes reduce power consumption:

- Sleep mode stops the processor clock.
- Deep-sleep mode stops the system clock and switches off the PLL and Flash memory.

The `SLEEPDEEP` bit of the **System Control (SYSCTRL)** register selects which sleep mode is used (see page 167). For more information about the behavior of the sleep modes, see “System Control” on page 227.

This section describes the mechanisms for entering sleep mode and the conditions for waking up from sleep mode, both of which apply to Sleep mode and Deep-sleep mode.

2.7.1 Entering Sleep Modes

This section describes the mechanisms software can use to put the processor into one of the sleep modes.

The system can generate spurious wake-up events, for example a debug operation wakes up the processor. Therefore, software must be able to put the processor back into sleep mode after such an event. A program might have an idle loop to put the processor back to sleep mode.

2.7.1.1 Wait for Interrupt

The wait for interrupt instruction, `WFI`, causes immediate entry to sleep mode unless the wake-up condition is true (see “Wake Up from WFI or Sleep-on-Exit” on page 116). When the processor executes a `WFI` instruction, it stops executing instructions and enters sleep mode. See the *Cortex™-M3/M4 Instruction Set Technical User's Manual* for more information.

2.7.1.2 Wait for Event

The wait for event instruction, `WFE`, causes entry to sleep mode conditional on the value of a one-bit event register. When the processor executes a `WFE` instruction, it checks the event register. If the register is 0, the processor stops executing instructions and enters sleep mode. If the register is 1, the processor clears the register and continues executing instructions without entering sleep mode.

If the event register is 1, the processor must not enter sleep mode on execution of a `WFE` instruction. Typically, this situation occurs if an `SEV` instruction has been executed. Software cannot access this register directly.

See the *Cortex™-M3/M4 Instruction Set Technical User's Manual* for more information.

2.7.1.3 Sleep-on-Exit

If the `SLEEPEXIT` bit of the **SYSCTRL** register is set, when the processor completes the execution of all exception handlers, it returns to Thread mode and immediately enters sleep mode. This mechanism can be used in applications that only require the processor to run when an exception occurs.

2.7.2 Wake Up from Sleep Mode

The conditions for the processor to wake up depend on the mechanism that cause it to enter sleep mode.

2.7.2.1 Wake Up from WFI or Sleep-on-Exit

Normally, the processor wakes up only when the NVIC detects an exception with sufficient priority to cause exception entry. Some embedded systems might have to execute system restore tasks after the processor wakes up and before executing an interrupt handler. Entry to the interrupt handler can be delayed by setting the `PRIMASK` bit and clearing the `FAULTMASK` bit. If an interrupt arrives that is enabled and has a higher priority than current exception priority, the processor wakes up but does not execute the interrupt handler until the processor clears `PRIMASK`. For more information about **PRIMASK** and **FAULTMASK**, see page 86 and page 87.

2.7.2.2 Wake Up from WFE

The processor wakes up if it detects an exception with sufficient priority to cause exception entry.

In addition, if the `SEVONPEND` bit in the **SYSCTRL** register is set, any new pending interrupt triggers an event and wakes up the processor, even if the interrupt is disabled or has insufficient priority to cause exception entry. For more information about **SYSCTRL**, see page 167.

2.7.3 The Wake-Up Interrupt Controller

The Wake-Up Interrupt Controller (WIC) is a peripheral that can detect an interrupt and wake the processor from deep sleep mode. The WIC is enabled only when the `DEEPSLEEP` bit in the **SCR** register is set (see page 167).

The WIC is not programmable, and does not have any registers or user interface. It operates entirely from hardware signals.

When the WIC is enabled and the processor enters deep sleep mode, the power management unit in the system can power down most of the Cortex-M4F processor. This has the side effect of stopping the SysTick timer. When the WIC receives an interrupt, it takes a number of clock cycles to wake up the processor and restore its state, before it can process the interrupt. This means interrupt latency is increased in deep sleep mode.

Note: If the processor detects a connection to a debugger it disables the WIC.

2.8 Instruction Set Summary

The processor implements a version of the Thumb instruction set. Table 2-13 on page 116 lists the supported instructions.

Note: In Table 2-13 on page 116:

- Angle brackets, `<>`, enclose alternative forms of the operand
- Braces, `{}`, enclose optional operands
- The Operands column is not exhaustive
- `Op2` is a flexible second operand that can be either a register or a constant
- Most instructions can use an optional condition code suffix

For more information on the instructions and operands, see the instruction descriptions in the *ARM® Cortex™-M4 Technical Reference Manual*.

Table 2-13. Cortex-M4F Instruction Summary

Mnemonic	Operands	Brief Description	Flags
ADC, ADCS	{Rd,} Rn, Op2	Add with carry	N, Z, C, V
ADD, ADDS	{Rd,} Rn, Op2	Add	N, Z, C, V
ADD, ADDW	{Rd,} Rn, #imm12	Add	-

Table 2-13. Cortex-M4F Instruction Summary (continued)

Mnemonic	Operands	Brief Description	Flags
ADR	Rd, label	Load PC-relative address	-
AND, ANDS	{Rd,} Rn, Op2	Logical AND	N, Z, C
ASR, ASRS	Rd, Rm, <Rs #n>	Arithmetic shift right	N, Z, C
B	label	Branch	-
BFC	Rd, #lsb, #width	Bit field clear	-
BFI	Rd, Rn, #lsb, #width	Bit field insert	-
BIC, BICS	{Rd,} Rn, Op2	Bit clear	N, Z, C
BKPT	#imm	Breakpoint	-
BL	label	Branch with link	-
BLX	Rm	Branch indirect with link	-
BX	Rm	Branch indirect	-
CBNZ	Rn, label	Compare and branch if non-zero	-
CBZ	Rn, label	Compare and branch if zero	-
CLREX	-	Clear exclusive	-
CLZ	Rd, Rm	Count leading zeros	-
CMN	Rn, Op2	Compare negative	N, Z, C, V
CMP	Rn, Op2	Compare	N, Z, C, V
CPSID	i	Change processor state, disable interrupts	-
CPSIE	i	Change processor state, enable interrupts	-
DMB	-	Data memory barrier	-
DSB	-	Data synchronization barrier	-
EOR, EORS	{Rd,} Rn, Op2	Exclusive OR	N, Z, C
ISB	-	Instruction synchronization barrier	-
IT	-	If-Then condition block	-
LDM	Rn{!}, reglist	Load multiple registers, increment after	-
LDMDB, LDMEA	Rn{!}, reglist	Load multiple registers, decrement before	-
LDMFD, LDMIA	Rn{!}, reglist	Load multiple registers, increment after	-
LDR	Rt, [Rn, #offset]	Load register with word	-
LDRB, LDRBT	Rt, [Rn, #offset]	Load register with byte	-
LDRD	Rt, Rt2, [Rn, #offset]	Load register with two bytes	-
LDREX	Rt, [Rn, #offset]	Load register exclusive	-
LDREXB	Rt, [Rn]	Load register exclusive with byte	-
LDREXH	Rt, [Rn]	Load register exclusive with halfword	-
LDRH, LDRHT	Rt, [Rn, #offset]	Load register with halfword	-
LDRSB, LDRSBT	Rt, [Rn, #offset]	Load register with signed byte	-
LDRSH, LDRSHT	Rt, [Rn, #offset]	Load register with signed halfword	-
LDRT	Rt, [Rn, #offset]	Load register with word	-
LSL, LSLS	Rd, Rm, <Rs #n>	Logical shift left	N, Z, C
LSR, LSRS	Rd, Rm, <Rs #n>	Logical shift right	N, Z, C

Table 2-13. Cortex-M4F Instruction Summary (continued)

Mnemonic	Operands	Brief Description	Flags
MLA	Rd, Rn, Rm, Ra	Multiply with accumulate, 32-bit result	-
MLS	Rd, Rn, Rm, Ra	Multiply and subtract, 32-bit result	-
MOV, MOVS	Rd, Op2	Move	N, Z, C
MOV, MOVW	Rd, #imm16	Move 16-bit constant	N, Z, C
MOVT	Rd, #imm16	Move top	-
MRS	Rd, spec_reg	Move from special register to general register	-
MSR	spec_reg, Rm	Move from general register to special register	N, Z, C, V
MUL, MULS	{Rd,} Rn, Rm	Multiply, 32-bit result	N, Z
MVN, MVNS	Rd, Op2	Move NOT	N, Z, C
NOP	-	No operation	-
ORN, ORNS	{Rd,} Rn, Op2	Logical OR NOT	N, Z, C
ORR, ORRS	{Rd,} Rn, Op2	Logical OR	N, Z, C
PKHTB, PKHBT	{Rd,} Rn, Rm, Op2	Pack halfword	-
POP	reglist	Pop registers from stack	-
PUSH	reglist	Push registers onto stack	-
QADD	{Rd,} Rn, Rm	Saturating add	Q
QADD16	{Rd,} Rn, Rm	Saturating add 16	-
QADD8	{Rd,} Rn, Rm	Saturating add 8	-
QASX	{Rd,} Rn, Rm	Saturating add and subtract with exchange	-
QDADD	{Rd,} Rn, Rm	Saturating double and add	Q
QDSUB	{Rd,} Rn, Rm	Saturating double and subtract	Q
QSAX	{Rd,} Rn, Rm	Saturating subtract and add with exchange	-
QSUB	{Rd,} Rn, Rm	Saturating subtract	Q
QSUB16	{Rd,} Rn, Rm	Saturating subtract 16	-
QSUB8	{Rd,} Rn, Rm	Saturating subtract 8	-
RBIT	Rd, Rn	Reverse bits	-
REV	Rd, Rn	Reverse byte order in a word	-
REV16	Rd, Rn	Reverse byte order in each halfword	-
REVSH	Rd, Rn	Reverse byte order in bottom halfword and sign extend	-
ROR, RORS	Rd, Rm, <Rs #n>	Rotate right	N, Z, C
RRX, RRXS	Rd, Rm	Rotate right with extend	N, Z, C
RSB, RSBS	{Rd,} Rn, Op2	Reverse subtract	N, Z, C, V
SADD16	{Rd,} Rn, Rm	Signed add 16	GE
SADD8	{Rd,} Rn, Rm	Signed add 8	GE
SASX	{Rd,} Rn, Rm	Signed add and subtract with exchange	GE
SBC, SBCS	{Rd,} Rn, Op2	Subtract with carry	N, Z, C, V
SBFX	Rd, Rn, #lsb, #width	Signed bit field extract	-
SDIV	{Rd,} Rn, Rm	Signed divide	-

Table 2-13. Cortex-M4F Instruction Summary (continued)

Mnemonic	Operands	Brief Description	Flags
SEL	{Rd,} Rn, Rm	Select bytes	-
SEV	-	Send event	-
SHADD16	{Rd,} Rn, Rm	Signed halving add 16	-
SHADD8	{Rd,} Rn, Rm	Signed halving add 8	-
SHASX	{Rd,} Rn, Rm	Signed halving add and subtract with exchange	-
SHSAX	{Rd,} Rn, Rm	Signed halving add and subtract with exchange	-
SHSUB16	{Rd,} Rn, Rm	Signed halving subtract 16	-
SHSUB8	{Rd,} Rn, Rm	Signed halving subtract 8	-
SMLABB, SMLABT, SMLATB, SMLATT	Rd, Rn, Rm, Ra	Signed multiply accumulate long (halfwords)	Q
SMLAD, SMLADX	Rd, Rn, Rm, Ra	Signed multiply accumulate dual	Q
SMLAL	RdLo, RdHi, Rn, Rm	Signed multiply with accumulate (32x32+64), 64-bit result	-
SMLALBB, SMLALBT, SMLALTB, SMLALTT	RdLo, RdHi, Rn, Rm	Signed multiply accumulate long (halfwords)	-
SMLALD, SMLALDX	RdLo, RdHi, Rn, Rm	Signed multiply accumulate long dual	-
SMLAWB, SMLAWT	Rd, Rn, Rm, Ra	Signed multiply accumulate, word by halfword	Q
SMLSD SMLSDX	Rd, Rn, Rm, Ra	Signed multiply subtract dual	Q
SMLSLD SMLSLDX	RdLo, RdHi, Rn, Rm	Signed multiply subtract long dual	-
SMMLA	Rd, Rn, Rm, Ra	Signed most significant word multiply accumulate	-
SMMLS, SMMLR	Rd, Rn, Rm, Ra	Signed most significant word multiply subtract	-
SMMUL, SMMULR	{Rd,} Rn, Rm	Signed most significant word multiply	-
SMUAD SMUADX	{Rd,} Rn, Rm	Signed dual multiply add	Q
SMULBB, SMULBT, SMULTB, SMULTT	{Rd,} Rn, Rm	Signed multiply halfwords	-
SMULL	RdLo, RdHi, Rn, Rm	Signed multiply (32x32), 64-bit result	-
SMULWB, SMULWT	{Rd,} Rn, Rm	Signed multiply by halfword	-

Table 2-13. Cortex-M4F Instruction Summary (continued)

Mnemonic	Operands	Brief Description	Flags
SMUSD, SMUSDX	{Rd,} Rn, Rm	Signed dual multiply subtract	-
SSAT	Rd, #n, Rm {,shift #s}	Signed saturate	Q
SSAT16	Rd, #n, Rm	Signed saturate 16	Q
SSAX	{Rd,} Rn, Rm	Saturating subtract and add with exchange	GE
SSUB16	{Rd,} Rn, Rm	Signed subtract 16	-
SSUB8	{Rd,} Rn, Rm	Signed subtract 8	-
STM	Rn{!}, reglist	Store multiple registers, increment after	-
STMDB, STMEA	Rn{!}, reglist	Store multiple registers, decrement before	-
STMFD, STMIA	Rn{!}, reglist	Store multiple registers, increment after	-
STR	Rt, [Rn {, #offset}]	Store register word	-
STRB, STRBT	Rt, [Rn {, #offset}]	Store register byte	-
STRD	Rt, Rt2, [Rn {, #offset}]	Store register two words	-
STREX	Rt, Rt, [Rn {, #offset}]	Store register exclusive	-
STREXB	Rd, Rt, [Rn]	Store register exclusive byte	-
STREXH	Rd, Rt, [Rn]	Store register exclusive halfword	-
STRH, STRHT	Rt, [Rn {, #offset}]	Store register halfword	-
STRSB, STRSBT	Rt, [Rn {, #offset}]	Store register signed byte	-
STRSH, STRSHT	Rt, [Rn {, #offset}]	Store register signed halfword	-
STRT	Rt, [Rn {, #offset}]	Store register word	-
SUB, SUBS	{Rd,} Rn, Op2	Subtract	N,Z,C,V
SUB, SUBW	{Rd,} Rn, #imm12	Subtract 12-bit constant	N,Z,C,V
SVC	#imm	Supervisor call	-
SXTAB	{Rd,} Rn, Rm, {,ROR #}	Extend 8 bits to 32 and add	-
SXTAB16	{Rd,} Rn, Rm, {,ROR #}	Dual extend 8 bits to 16 and add	-
SXTAH	{Rd,} Rn, Rm, {,ROR #}	Extend 16 bits to 32 and add	-
SXTB16	{Rd,} Rm {,ROR #n}	Signed extend byte 16	-
SXTB	{Rd,} Rm {,ROR #n}	Sign extend a byte	-
SXTH	{Rd,} Rm {,ROR #n}	Sign extend a halfword	-
TBB	[Rn, Rm]	Table branch byte	-
TBH	[Rn, Rm, LSL #1]	Table branch halfword	-
TEQ	Rn, Op2	Test equivalence	N,Z,C
TST	Rn, Op2	Test	N,Z,C
UADD16	{Rd,} Rn, Rm	Unsigned add 16	GE
UADD8	{Rd,} Rn, Rm	Unsigned add 8	GE
UASX	{Rd,} Rn, Rm	Unsigned add and subtract with exchange	GE
UHADD16	{Rd,} Rn, Rm	Unsigned halving add 16	-
UHADD8	{Rd,} Rn, Rm	Unsigned halving add 8	-
UHASX	{Rd,} Rn, Rm	Unsigned halving add and subtract with exchange	-

Table 2-13. Cortex-M4F Instruction Summary (continued)

Mnemonic	Operands	Brief Description	Flags
UHSAX	{Rd,} Rn, Rm	Unsigned halving subtract and add with exchange	-
UHSUB16	{Rd,} Rn, Rm	Unsigned halving subtract 16	-
UHSUB8	{Rd,} Rn, Rm	Unsigned halving subtract 8	-
UBFX	Rd, Rn, #lsb, #width	Unsigned bit field extract	-
UDIV	{Rd,} Rn, Rm	Unsigned divide	-
UMAAL	RdLo, RdHi, Rn, Rm	Unsigned multiply accumulate accumulate long (32x32+64), 64-bit result	-
UMLAL	RdLo, RdHi, Rn, Rm	Unsigned multiply with accumulate (32x32+32+32), 64-bit result	-
UMULL	RdLo, RdHi, Rn, Rm	Unsigned multiply (32x 2), 64-bit result	-
UQADD16	{Rd,} Rn, Rm	Unsigned Saturating Add 16	-
UQADD8	{Rd,} Rn, Rm	Unsigned Saturating Add 8	-
UQASX	{Rd,} Rn, Rm	Unsigned Saturating Add and Subtract with Exchange	-
UQSAX	{Rd,} Rn, Rm	Unsigned Saturating Subtract and Add with Exchange	-
UQSUB16	{Rd,} Rn, Rm	Unsigned Saturating Subtract 16	-
UQSUB8	{Rd,} Rn, Rm	Unsigned Saturating Subtract 8	-
USAD8	{Rd,} Rn, Rm	Unsigned Sum of Absolute Differences	-
USADA8	{Rd,} Rn, Rm, Ra	Unsigned Sum of Absolute Differences and Accumulate	-
USAT	Rd, #n, Rm {,shift #s}	Unsigned Saturate	Q
USAT16	Rd, #n, Rm	Unsigned Saturate 16	Q
USAX	{Rd,} Rn, Rm	Unsigned Subtract and add with Exchange	GE
USUB16	{Rd,} Rn, Rm	Unsigned Subtract 16	GE
USUB8	{Rd,} Rn, Rm	Unsigned Subtract 8	GE
UXTAB	{Rd,} Rn, Rm, {,ROR #}	Rotate, extend 8 bits to 32 and Add	-
UXTAB16	{Rd,} Rn, Rm, {,ROR #}	Rotate, dual extend 8 bits to 16 and Add	-
UXTAH	{Rd,} Rn, Rm, {,ROR #}	Rotate, unsigned extend and Add Halfword	-
UXTB	{Rd,} Rm, {,ROR #n}	Zero extend a Byte	-
UXTB16	{Rd,} Rm, {,ROR #n}	Unsigned Extend Byte 16	-
UXTH	{Rd,} Rm, {,ROR #n}	Zero extend a Halfword	-
VABS.F32	Sd, Sm	Floating-point Absolute	-
VADD.F32	{Sd,} Sn, Sm	Floating-point Add	-
VCMP.F32	Sd, <Sm #0.0>	Compare two floating-point registers, or one floating-point register and zero	FPSCR
VCMPE.F32	Sd, <Sm #0.0>	Compare two floating-point registers, or one floating-point register and zero with Invalid Operation check	FPSCR
VCVT.S32.F32	Sd, Sm	Convert between floating-point and integer	-

Table 2-13. Cortex-M4F Instruction Summary (continued)

Mnemonic	Operands	Brief Description	Flags
VCVT.S16.F32	Sd, Sd, #fbits	Convert between floating-point and fixed point	-
VCVTR.S32.F32	Sd, Sm	Convert between floating-point and integer with rounding	-
VCVT<B H>.F32.F16	Sd, Sm	Converts half-precision value to single-precision	-
VCVTT<B T>.F32.F16	Sd, Sm	Converts single-precision register to half-precision	-
VDIV.F32	{Sd,} Sn, Sm	Floating-point Divide	-
VFMA.F32	{Sd,} Sn, Sm	Floating-point Fused Multiply Accumulate	-
VFNMA.F32	{Sd,} Sn, Sm	Floating-point Fused Negate Multiply Accumulate	-
VFMS.F32	{Sd,} Sn, Sm	Floating-point Fused Multiply Subtract	-
VFNMS.F32	{Sd,} Sn, Sm	Floating-point Fused Negate Multiply Subtract	-
VLDM.F<32 64>	Rn{!}, list	Load Multiple extension registers	-
VLDR.F<32 64>	<Dd Sd>, [Rn]	Load an extension register from memory	-
VLMA.F32	{Sd,} Sn, Sm	Floating-point Multiply Accumulate	-
VLMS.F32	{Sd,} Sn, Sm	Floating-point Multiply Subtract	-
VMOV.F32	Sd, #imm	Floating-point Move immediate	-
VMOV	Sd, Sm	Floating-point Move register	-
VMOV	Sn, Rt	Copy ARM core register to single precision	-
VMOV	Sm, Sm1, Rt, Rt2	Copy 2 ARM core registers to 2 single precision	-
VMOV	Dd[x], Rt	Copy ARM core register to scalar	-
VMOV	Rt, Dn[x]	Copy scalar to ARM core register	-
VMRS	Rt, FPSCR	Move FPSCR to ARM core register or APSR	N, Z, C, V
VMSR	FPSCR, Rt	Move to FPSCR from ARM Core register	FPSCR
VMUL.F32	{Sd,} Sn, Sm	Floating-point Multiply	-
VNEG.F32	Sd, Sm	Floating-point Negate	-
VNMLA.F32	{Sd,} Sn, Sm	Floating-point Multiply and Add	-
VNMLS.F32	{Sd,} Sn, Sm	Floating-point Multiply and Subtract	-
VNMUL	{Sd,} Sn, Sm	Floating-point Multiply	-
VPOP	list	Pop extension registers	-
VPUSH	list	Push extension registers	-
VSQRT.F32	Sd, Sm	Calculates floating-point Square Root	-
VSTM	Rn{!}, list	Floating-point register Store Multiple	-
VSTR.F3<32 64>	Sd, [Rn]	Stores an extension register to memory	-
VSUB.F<32 64>	{Sd,} Sn, Sm	Floating-point Subtract	-
WFE	-	Wait for event	-
WFI	-	Wait for interrupt	-

3 Cortex-M4 Peripherals

This chapter provides information on the Stellaris® implementation of the Cortex-M4 processor peripherals, including:

- **SysTick** (see page 124)
 - Provides a simple, 24-bit clear-on-write, decrementing, wrap-on-zero counter with a flexible control mechanism.
- **Nested Vectored Interrupt Controller (NVIC)** (see page 125)
 - Facilitates low-latency exception and interrupt handling
 - Controls power management
 - Implements system control registers
- **System Control Block (SCB)** (see page 126)
 - Provides system implementation information and system control, including configuration, control, and reporting of system exceptions.
- **Memory Protection Unit (MPU)** (see page 126)
 - Supports the standard ARMv7 Protected Memory System Architecture (PMSA) model. The MPU provides full support for protection regions, overlapping protection regions, access permissions, and exporting memory attributes to the system.
- **Floating-Point Unit (FPU)** (see page 131)
 - Fully supports single-precision add, subtract, multiply, divide, multiply and accumulate, and square root operations. It also provides conversions between fixed-point and floating-point data formats, and floating-point constant instructions.

Table 3-1 on page 123 shows the address map of the Private Peripheral Bus (PPB). Some peripheral register regions are split into two address regions, as indicated by two addresses listed.

Table 3-1. Core Peripheral Register Regions

Address	Core Peripheral	Description (see page ...)
0xE000.E010-0xE000.E01F	System Timer	124
0xE000.E100-0xE000.E4EF 0xE000.EF00-0xE000.EF03	Nested Vectored Interrupt Controller	125
0xE000.E008-0xE000.E00F 0xE000.ED00-0xE000.ED3F	System Control Block	126
0xE000.ED90-0xE000.EDB8	Memory Protection Unit	126
0xE000.EF30-0xE000.EF44	Floating Point Unit	131

3.1 Functional Description

This chapter provides information on the Stellaris implementation of the Cortex-M4 processor peripherals: SysTick, NVIC, SCB and MPU.

3.1.1 System Timer (SysTick)

Cortex-M4 includes an integrated system timer, SysTick, which provides a simple, 24-bit clear-on-write, decrementing, wrap-on-zero counter with a flexible control mechanism. The counter can be used in several different ways, for example as:

- An RTOS tick timer that fires at a programmable rate (for example, 100 Hz) and invokes a SysTick routine.
- A high-speed alarm timer using the system clock.
- A variable rate alarm or signal timer—the duration is range-dependent on the reference clock used and the dynamic range of the counter.
- A simple counter used to measure time to completion and time used.
- An internal clock source control based on missing/meeting durations. The `COUNT` bit in the **STCTRL** control and status register can be used to determine if an action completed within a set duration, as part of a dynamic clock management control loop.

The timer consists of three registers:

- **SysTick Control and Status (STCTRL)**: A control and status counter to configure its clock, enable the counter, enable the SysTick interrupt, and determine counter status.
- **SysTick Reload Value (STRELOAD)**: The reload value for the counter, used to provide the counter's wrap value.
- **SysTick Current Value (STCURRENT)**: The current value of the counter.

When enabled, the timer counts down on each clock from the reload value to zero, reloads (wraps) to the value in the **STRELOAD** register on the next clock edge, then decrements on subsequent clocks. Clearing the **STRELOAD** register disables the counter on the next wrap. When the counter reaches zero, the `COUNT` status bit is set. The `COUNT` bit clears on reads.

Writing to the **STCURRENT** register clears the register and the `COUNT` status bit. The write does not trigger the SysTick exception logic. On a read, the current value is the value of the register at the time the register is accessed.

The SysTick counter runs on either the system clock or the precision internal oscillator (PIOSC) divided by 4. If this clock signal is stopped for low power mode, the SysTick counter stops. SysTick can be kept running during Deep-sleep mode by setting the `CLK_SRC` bit in the **SysTick Control and Status Register (STCTRL)** register and ensuring that the `PIOSCPD` bit in the **Deep Sleep Clock Configuration (DSLPCCLKCFG)** register is clear. Ensure software uses aligned word accesses to access the SysTick registers.

The SysTick counter reload and current value are undefined at reset; the correct initialization sequence for the SysTick counter is:

1. Program the value in the **STRELOAD** register.
2. Clear the **STCURRENT** register by writing to it with any value.
3. Configure the **STCTRL** register for the required operation.

Note: When the processor is halted for debugging, the counter does not decrement.

3.1.2 Nested Vectored Interrupt Controller (NVIC)

This section describes the Nested Vectored Interrupt Controller (NVIC) and the registers it uses. The NVIC supports:

- 80 interrupts.
- A programmable priority level of 0-7 for each interrupt. A higher level corresponds to a lower priority, so level 0 is the highest interrupt priority.
- Low-latency exception and interrupt handling.
- Level and pulse detection of interrupt signals.
- Dynamic reprioritization of interrupts.
- Grouping of priority values into group priority and subpriority fields.
- Interrupt tail-chaining.
- An external Non-maskable interrupt (NMI).

The processor automatically stacks its state on exception entry and unstacks this state on exception exit, with no instruction overhead, providing low latency exception handling.

3.1.2.1 Level-Sensitive and Pulse Interrupts

The processor supports both level-sensitive and pulse interrupts. Pulse interrupts are also described as edge-triggered interrupts.

A level-sensitive interrupt is held asserted until the peripheral deasserts the interrupt signal. Typically this happens because the ISR accesses the peripheral, causing it to clear the interrupt request. A pulse interrupt is an interrupt signal sampled synchronously on the rising edge of the processor clock. To ensure the NVIC detects the interrupt, the peripheral must assert the interrupt signal for at least one clock cycle, during which the NVIC detects the pulse and latches the interrupt.

When the processor enters the ISR, it automatically removes the pending state from the interrupt (see “Hardware and Software Control of Interrupts” on page 125 for more information). For a level-sensitive interrupt, if the signal is not deasserted before the processor returns from the ISR, the interrupt becomes pending again, and the processor must execute its ISR again. As a result, the peripheral can hold the interrupt signal asserted until it no longer needs servicing.

3.1.2.2 Hardware and Software Control of Interrupts

The Cortex-M4 latches all interrupts. A peripheral interrupt becomes pending for one of the following reasons:

- The NVIC detects that the interrupt signal is High and the interrupt is not active.
- The NVIC detects a rising edge on the interrupt signal.
- Software writes to the corresponding interrupt set-pending register bit, or to the **Software Trigger Interrupt (SWTRIG)** register to make a Software-Generated Interrupt pending. See the `INT` bit in the **PEND0** register on page 147 or **SWTRIG** on page 157.

A pending interrupt remains pending until one of the following:

- The processor enters the ISR for the interrupt, changing the state of the interrupt from pending to active. Then:
 - For a level-sensitive interrupt, when the processor returns from the ISR, the NVIC samples the interrupt signal. If the signal is asserted, the state of the interrupt changes to pending, which might cause the processor to immediately re-enter the ISR. Otherwise, the state of the interrupt changes to inactive.
 - For a pulse interrupt, the NVIC continues to monitor the interrupt signal, and if this is pulsed the state of the interrupt changes to pending and active. In this case, when the processor returns from the ISR the state of the interrupt changes to pending, which might cause the processor to immediately re-enter the ISR.

If the interrupt signal is not pulsed while the processor is in the ISR, when the processor returns from the ISR the state of the interrupt changes to inactive.
- Software writes to the corresponding interrupt clear-pending register bit
 - For a level-sensitive interrupt, if the interrupt signal is still asserted, the state of the interrupt does not change. Otherwise, the state of the interrupt changes to inactive.
 - For a pulse interrupt, the state of the interrupt changes to inactive, if the state was pending or to active, if the state was active and pending.

3.1.3 System Control Block (SCB)

The System Control Block (SCB) provides system implementation information and system control, including configuration, control, and reporting of the system exceptions.

3.1.4 Memory Protection Unit (MPU)

This section describes the Memory protection unit (MPU). The MPU divides the memory map into a number of regions and defines the location, size, access permissions, and memory attributes of each region. The MPU supports independent attribute settings for each region, overlapping regions, and export of memory attributes to the system.

The memory attributes affect the behavior of memory accesses to the region. The Cortex-M4 MPU defines eight separate memory regions, 0-7, and a background region.

When memory regions overlap, a memory access is affected by the attributes of the region with the highest number. For example, the attributes for region 7 take precedence over the attributes of any region that overlaps region 7.

The background region has the same memory access attributes as the default memory map, but is accessible from privileged software only.

The Cortex-M4 MPU memory map is unified, meaning that instruction accesses and data accesses have the same region settings.

If a program accesses a memory location that is prohibited by the MPU, the processor generates a memory management fault, causing a fault exception and possibly causing termination of the process in an OS environment. In an OS environment, the kernel can update the MPU region setting dynamically based on the process to be executed. Typically, an embedded OS uses the MPU for memory protection.

Configuration of MPU regions is based on memory types (see “Memory Regions, Types and Attributes” on page 96 for more information).

Table 3-2 on page 127 shows the possible MPU region attributes. See the section called “MPU Configuration for a Stellaris Microcontroller” on page 131 for guidelines for programming a microcontroller implementation.

Table 3-2. Memory Attributes Summary

Memory Type	Description
Strongly Ordered	All accesses to Strongly Ordered memory occur in program order.
Device	Memory-mapped peripherals
Normal	Normal memory

To avoid unexpected behavior, disable the interrupts before updating the attributes of a region that the interrupt handlers might access.

Ensure software uses aligned accesses of the correct size to access MPU registers:

- Except for the **MPU Region Attribute and Size (MPUATTR)** register, all MPU registers must be accessed with aligned word accesses.
- The **MPUATTR** register can be accessed with byte or aligned halfword or word accesses.

The processor does not support unaligned accesses to MPU registers.

When setting up the MPU, and if the MPU has previously been programmed, disable unused regions to prevent any previous region settings from affecting the new MPU setup.

3.1.4.1 Updating an MPU Region

To update the attributes for an MPU region, the **MPU Region Number (MPUNUMBER)**, **MPU Region Base Address (MPUBASE)** and **MPUATTR** registers must be updated. Each register can be programmed separately or with a multiple-word write to program all of these registers. You can use the **MPUBASEx** and **MPUATTRx** aliases to program up to four regions simultaneously using an *STM* instruction.

Updating an MPU Region Using Separate Words

This example simple code configures one region:

```

; R1 = region number
; R2 = size/enable
; R3 = attributes
; R4 = address
LDR R0,=MPUNUMBER      ; 0xE000ED98, MPU region number register
STR R1, [R0, #0x0]     ; Region Number
STR R4, [R0, #0x4]     ; Region Base Address
STRH R2, [R0, #0x8]   ; Region Size and Enable
STRH R3, [R0, #0xA]   ; Region Attribute

```

Disable a region before writing new region settings to the MPU if you have previously enabled the region being changed. For example:

```

; R1 = region number
; R2 = size/enable
; R3 = attributes
; R4 = address
LDR R0,=MPUNUMBER      ; 0xE000ED98, MPU region number register

```

```

STR R1, [R0, #0x0]      ; Region Number
BIC R2, R2, #1          ; Disable
STRH R2, [R0, #0x8]    ; Region Size and Enable
STR R4, [R0, #0x4]     ; Region Base Address
STRH R3, [R0, #0xA]    ; Region Attribute
ORR R2, #1             ; Enable
STRH R2, [R0, #0x8]    ; Region Size and Enable

```

Software must use memory barrier instructions:

- Before MPU setup, if there might be outstanding memory transfers, such as buffered writes, that might be affected by the change in MPU settings.
- After MPU setup, if it includes memory transfers that must use the new MPU settings.

However, memory barrier instructions are not required if the MPU setup process starts by entering an exception handler, or is followed by an exception return, because the exception entry and exception return mechanism cause memory barrier behavior.

Software does not need any memory barrier instructions during MPU setup, because it accesses the MPU through the Private Peripheral Bus (PPB), which is a Strongly Ordered memory region.

For example, if all of the memory access behavior is intended to take effect immediately after the programming sequence, then a DSB instruction and an ISB instruction should be used. A DSB is required after changing MPU settings, such as at the end of context switch. An ISB is required if the code that programs the MPU region or regions is entered using a branch or call. If the programming sequence is entered using a return from exception, or by taking an exception, then an ISB is not required.

Updating an MPU Region Using Multi-Word Writes

The MPU can be programmed directly using multi-word writes, depending how the information is divided. Consider the following reprogramming:

```

; R1 = region number
; R2 = address
; R3 = size, attributes in one
LDR R0, =MPUNUMBER ; 0xE000ED98, MPU region number register
STR R1, [R0, #0x0] ; Region Number
STR R2, [R0, #0x4] ; Region Base Address
STR R3, [R0, #0x8] ; Region Attribute, Size and Enable

```

An STM instruction can be used to optimize this:

```

; R1 = region number
; R2 = address
; R3 = size, attributes in one
LDR R0, =MPUNUMBER ; 0xE000ED98, MPU region number register
STM R0, {R1-R3}    ; Region number, address, attribute, size and enable

```

This operation can be done in two words for pre-packed information, meaning that the **MPU Region Base Address (MPUBASE)** register (see page 191) contains the required region number and has the VALID bit set. This method can be used when the data is statically packed, for example in a boot loader:

```

; R1 = address and region number in one
; R2 = size and attributes in one
LDR R0, =MPUBASE      ; 0xE000ED9C, MPU Region Base register
STR R1, [R0, #0x0]    ; Region base address and region number combined
                        ; with VALID (bit 4) set
STR R2, [R0, #0x4]    ; Region Attribute, Size and Enable

```

Subregions

Regions of 256 bytes or more are divided into eight equal-sized subregions. Set the corresponding bit in the *SRD* field of the **MPU Region Attribute and Size (MPUATTR)** register (see page 193) to disable a subregion. The least-significant bit of the *SRD* field controls the first subregion, and the most-significant bit controls the last subregion. Disabling a subregion means another region overlapping the disabled range matches instead. If no other enabled region overlaps the disabled subregion, the MPU issues a fault.

Regions of 32, 64, and 128 bytes do not support subregions. With regions of these sizes, the *SRD* field must be configured to 0x00, otherwise the MPU behavior is unpredictable.

Example of SRD Use

Two regions with the same base address overlap. Region one is 128 KB, and region two is 512 KB. To ensure the attributes from region one apply to the first 128 KB region, configure the *SRD* field for region two to 0x03 to disable the first two subregions, as Figure 3-1 on page 129 shows.

Figure 3-1. SRD Use Example

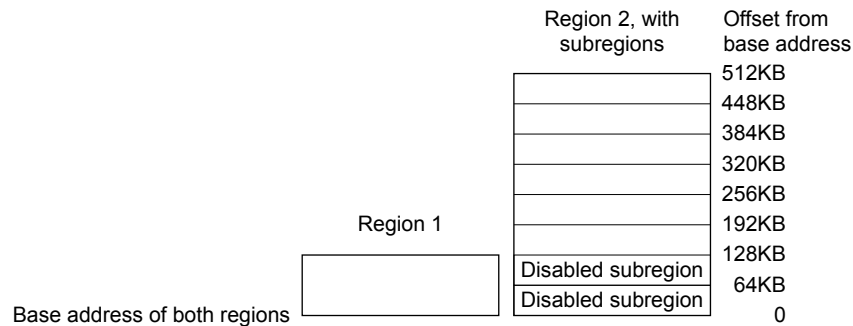

3.1.4.2 MPU Access Permission Attributes

The access permission bits, *TEX*, *S*, *C*, *B*, *AP*, and *XN* of the **MPUATTR** register, control access to the corresponding memory region. If an access is made to an area of memory without the required permissions, then the MPU generates a permission fault.

Table 3-3 on page 129 shows the encodings for the *TEX*, *C*, *B*, and *S* access permission bits. All encodings are shown for completeness, however the current implementation of the Cortex-M4 does not support the concept of cacheability or shareability. Refer to the section called “MPU Configuration for a Stellaris Microcontroller” on page 131 for information on programming the MPU for Stellaris implementations.

Table 3-3. TEX, S, C, and B Bit Field Encoding

TEX	S	C	B	Memory Type	Shareability	Other Attributes
000b	x ^a	0	0	Strongly Ordered	Shareable	-
000	x ^a	0	1	Device	Shareable	-

Table 3-3. TEX, S, C, and B Bit Field Encoding (continued)

TEX	S	C	B	Memory Type	Shareability	Other Attributes
000	0	1	0	Normal	Not shareable	Outer and inner write-through. No write allocate.
000	1	1	0	Normal	Shareable	
000	0	1	1	Normal	Not shareable	
000	1	1	1	Normal	Shareable	
001	0	0	0	Normal	Not shareable	Outer and inner noncacheable.
001	1	0	0	Normal	Shareable	
001	x ^a	0	1	Reserved encoding	-	-
001	x ^a	1	0	Reserved encoding	-	-
001	0	1	1	Normal	Not shareable	Outer and inner write-back. Write and read allocate.
001	1	1	1	Normal	Shareable	
010	x ^a	0	0	Device	Not shareable	Nonshared Device.
010	x ^a	0	1	Reserved encoding	-	-
010	x ^a	1	x ^a	Reserved encoding	-	-
1BB	0	A	A	Normal	Not shareable	Cached memory (BB = outer policy, AA = inner policy). See Table 3-4 for the encoding of the AA and BB bits.
1BB	1	A	A	Normal	Shareable	

a. The MPU ignores the value of this bit.

Table 3-4 on page 130 shows the cache policy for memory attribute encodings with a **TEX** value in the range of 0x4-0x7.

Table 3-4. Cache Policy for Memory Attribute Encoding

Encoding, AA or BB	Corresponding Cache Policy
00	Non-cacheable
01	Write back, write and read allocate
10	Write through, no write allocate
11	Write back, no write allocate

Table 3-5 on page 130 shows the **AP** encodings in the **MPUATTR** register that define the access permissions for privileged and unprivileged software.

Table 3-5. AP Bit Field Encoding

AP Bit Field	Privileged Permissions	Unprivileged Permissions	Description
000	No access	No access	All accesses generate a permission fault.
001	R/W	No access	Access from privileged software only.
010	R/W	RO	Writes by unprivileged software generate a permission fault.
011	R/W	R/W	Full access.
100	Unpredictable	Unpredictable	Reserved.
101	RO	No access	Reads by privileged software only.

Table 3-5. AP Bit Field Encoding (continued)

AP Bit Field	Privileged Permissions	Unprivileged Permissions	Description
110	RO	RO	Read-only, by privileged or unprivileged software.
111	RO	RO	Read-only, by privileged or unprivileged software.

MPU Configuration for a Stellaris Microcontroller

Stellaris microcontrollers have only a single processor and no caches. As a result, the MPU should be programmed as shown in Table 3-6 on page 131.

Table 3-6. Memory Region Attributes for Stellaris Microcontrollers

Memory Region	TEX	S	C	B	Memory Type and Attributes
Flash memory	000b	0	1	0	Normal memory, non-shareable, write-through
Internal SRAM	000b	1	1	0	Normal memory, shareable, write-through
External SRAM	000b	1	1	1	Normal memory, shareable, write-back, write-allocate
Peripherals	000b	1	0	1	Device memory, shareable

In current Stellaris microcontroller implementations, the shareability and cache policy attributes do not affect the system behavior. However, using these settings for the MPU regions can make the application code more portable. The values given are for typical situations.

3.1.4.3 MPU Mismatch

When an access violates the MPU permissions, the processor generates a memory management fault (see “Exceptions and Interrupts” on page 93 for more information). The **MFAULTSTAT** register indicates the cause of the fault. See page 178 for more information.

3.1.5 Floating-Point Unit (FPU)

This section describes the Floating-Point Unit (FPU) and the registers it uses. The FPU provides:

- 32-bit instructions for single-precision (C float) data-processing operations
- Combined Multiply and Accumulate instructions for increased precision (Fused MAC)
- Hardware support for conversion, addition, subtraction, multiplication with optional accumulate, division, and square-root
- Hardware support for denormals and all IEEE rounding modes
- 32 dedicated 32-bit single-precision registers, also addressable as 16 double-word registers
- Decoupled three stage pipeline

The Cortex-M4F FPU fully supports single-precision add, subtract, multiply, divide, multiply and accumulate, and square root operations. It also provides conversions between fixed-point and floating-point data formats, and floating-point constant instructions. The FPU provides floating-point computation functionality that is compliant with the ANSI/IEEE Std 754-2008, IEEE Standard for Binary Floating-Point Arithmetic, referred to as the IEEE 754 standard. The FPU's single-precision extension registers can also be accessed as 16 doubleword registers for load, store, and move operations.

3.1.5.1 FPU Views of the Register Bank

The FPU provides an extension register file containing 32 single-precision registers. These can be viewed as:

- Sixteen 64-bit doubleword registers, D0-D15
- Thirty-two 32-bit single-word registers, S0-S31
- A combination of registers from the above views

Figure 3-2. FPU Register Bank

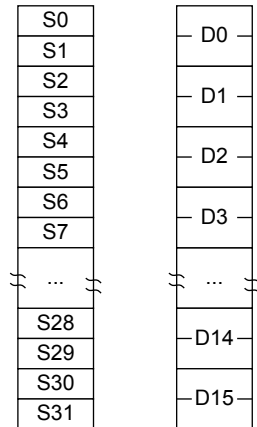

The mapping between the registers is as follows:

- $S\langle 2n \rangle$ maps to the least significant half of $D\langle n \rangle$
- $S\langle 2n+1 \rangle$ maps to the most significant half of $D\langle n \rangle$

For example, you can access the least significant half of the value in D6 by accessing S12, and the most significant half of the elements by accessing S13.

3.1.5.2 Modes of Operation

The FPU provides three modes of operation to accommodate a variety of applications.

Full-Compliance mode. In Full-Compliance mode, the FPU processes all operations according to the IEEE 754 standard in hardware.

Flush-to-Zero mode. Setting the **FZ** bit of the **Floating-Point Status and Control (FPSC)** register enables Flush-to-Zero mode. In this mode, the FPU treats all subnormal input operands of arithmetic CDP operations as zeros in the operation. Exceptions that result from a zero operand are signalled appropriately. VABS, VNEG, and VMOV are not considered arithmetic CDP operations and are not affected by Flush-to-Zero mode. A result that is tiny, as described in the IEEE 754 standard, where the destination precision is smaller in magnitude than the minimum normal value before rounding, is replaced with a zero. The **IDC** bit in **FPSC** indicates when an input flush occurs. The **UFC** bit in **FPSC** indicates when a result flush occurs.

Default NaN mode. Setting the **DN** bit in the **FPSC** register enables default NaN mode. In this mode, the result of any arithmetic data processing operation that involves an input NaN, or that generates a NaN result, returns the default NaN. Propagation of the fraction bits is maintained only by VABS,

VNEG, and VMOV operations. All other CDP operations ignore any information in the fraction bits of an input NaN.

3.1.5.3 Compliance with the IEEE 754 standard

When Default NaN (DN) and Flush-to-Zero (FZ) modes are disabled, FPv4 functionality is compliant with the IEEE 754 standard in hardware. No support code is required to achieve this compliance.

3.1.5.4 Complete Implementation of the IEEE 754 standard

The Cortex-M4F floating point instruction set does not support all operations defined in the IEEE 754-2008 standard. Unsupported operations include, but are not limited to the following:

- Remainder
- Round floating-point number to integer-valued floating-point number
- Binary-to-decimal conversions
- Decimal-to-binary conversions
- Direct comparison of single-precision and double-precision values

The Cortex-M4 FPU supports fused MAC operations as described in the IEEE standard. For complete implementation of the IEEE 754-2008 standard, floating-point functionality must be augmented with library functions.

3.1.5.5 IEEE 754 standard implementation choices

NaN handling

All single-precision values with the maximum exponent field value and a nonzero fraction field are valid NaNs. A most-significant fraction bit of zero indicates a Signaling NaN (SNaN). A one indicates a Quiet NaN (QNaN). Two NaN values are treated as different NaNs if they differ in any bit. The below table shows the default NaN values.

Sign	Fraction	Fraction
0	0xFF	bit [22] = 1, bits [21:0] are all zeros

Processing of input NaNs for ARM floating-point functionality and libraries is defined as follows:

- In full-compliance mode, NaNs are handled as described in the ARM Architecture Reference Manual. The hardware processes the NaNs directly for arithmetic CDP instructions. For data transfer operations, NaNs are transferred without raising the Invalid Operation exception. For the non-arithmetic CDP instructions, VABS, VNEG, and VMOV, NaNs are copied, with a change of sign if specified in the instructions, without causing the Invalid Operation exception.
- In default NaN mode, arithmetic CDP instructions involving NaN operands return the default NaN regardless of the fractions of any NaN operands. SNaNs in an arithmetic CDP operation set the IOC flag, FPSCR[0]. NaN handling by data transfer and non-arithmetic CDP instructions is the same as in full-compliance mode.

Table 3-7. QNaN and SNaN Handling

Instruction Type	Default NaN Mode	With QNaN Operand	With SNaN Operand
Arithmetic CDP	Off	The QNaN or one of the QNaN operands, if there is more than one, is returned according to the rules given in the ARM Architecture Reference Manual.	IOC ^a set. The SNaN is quieted and the result NaN is determined by the rules given in the ARM Architecture Reference Manual.
	On	Default NaN returns.	IOCa set. Default NaN returns.
Non-arithmetic CDP	Off/On	NaN passes to destination with sign changed as appropriate.	
FCMP(Z)	-	Unordered compare.	IOC set. Unordered compare.
FCMPE(Z)	-	IOC set. Unordered compare.	IOC set. Unordered compare.
Load/store	Off/On	All NaNs transferred.	

a. IOC is the Invalid Operation exception flag, FPSCR[0].

Comparisons

Comparison results modify the flags in the FPSCR. You can use the MVRS APSR_nzcv instruction (formerly FMSTAT) to transfer the current flags from the FPSCR to the APSR. See the ARM Architecture Reference Manual for mapping of IEEE 754-2008 standard predicates to ARM conditions. The flags used are chosen so that subsequent conditional execution of ARM instructions can test the predicates defined in the IEEE standard.

Underflow

The Cortex-M4F FPU uses the before rounding form of tininess and the inexact result form of loss of accuracy as described in the IEEE 754-2008 standard to generate Underflow exceptions.

In flush-to-zero mode, results that are tiny before rounding, as described in the IEEE standard, are flushed to a zero, and the UFC flag, FPSCR[3], is set. See the ARM Architecture Reference Manual for information on flush-to-zero mode.

When the FPU is not in flush-to-zero mode, operations are performed on subnormal operands. If the operation does not produce a tiny result, it returns the computed result, and the UFC flag, FPSCR[3], is not set. The IXC flag, FPSCR[4], is set if the operation is inexact. If the operation produces a tiny result, the result is a subnormal or zero value, and the UFC flag, FPSCR[3], is set if the result was also inexact.

3.1.5.6 Exceptions

The FPU sets the cumulative exception status flag in the FPSCR register as required for each instruction, in accordance with the FPv4 architecture. The FPU does not support user-mode traps. The exception enable bits in the FPSCR read-as-zero, and writes are ignored. The processor also has six output pins, FPIXC, FPUFC, FPOFC, FPDZC, FPIDC, and FPIOC, that each reflect the status of one of the cumulative exception flags. For a description of these outputs, see the *ARM Cortex-M4 Integration and Implementation Manual* (ARM DII 0239, available from ARM).

The processor can reduce the exception latency by using lazy stacking. See Auxiliary Control Register, ACTLR on page 4-5. This means that the processor reserves space on the stack for the FP state, but does not save that state information to the stack. See the ARMv7-M Architecture Reference Manual (available from ARM) for more information.

3.1.5.7 Enabling the FPU

The FPU is disabled from reset. You must enable it before you can use any floating-point instructions. The processor must be in privileged mode to read from and write to the **Coprocessor Access**

Control (CPAC) register. The below example code sequence enables the FPU in both privileged and user modes.

```
; CPACR is located at address 0xE000ED88
LDR.W R0, =0xE000ED88
; Read CPACR
LDR R1, [R0]
; Set bits 20-23 to enable CP10 and CP11 coprocessors
ORR R1, R1, #(0xF << 20)
; Write back the modified value to the CPACR
STR R1, [R0]; wait for store to complete
DSB
;reset pipeline now the FPU is enabled
ISB
```

3.2 Register Map

Table 3-8 on page 135 lists the Cortex-M4 Peripheral SysTick, NVIC, MPU, FPU and SCB registers. The offset listed is a hexadecimal increment to the register's address, relative to the Core Peripherals base address of 0xE000.E000.

Note: Register spaces that are not used are reserved for future or internal use. Software should not modify any reserved memory address.

Table 3-8. Peripherals Register Map

Offset	Name	Type	Reset	Description	See page
System Timer (SysTick) Registers					
0x010	STCTRL	R/W	0x0000.0004	SysTick Control and Status Register	139
0x014	STRELOAD	R/W	-	SysTick Reload Value Register	141
0x018	STCURRENT	R/WC	-	SysTick Current Value Register	142
Nested Vectored Interrupt Controller (NVIC) Registers					
0x100	EN0	R/W	0x0000.0000	Interrupt 0-31 Set Enable	143
0x104	EN1	R/W	0x0000.0000	Interrupt 32-63 Set Enable	143
0x108	EN2	R/W	0x0000.0000	Interrupt 64-95 Set Enable	143
0x10C	EN3	R/W	0x0000.0000	Interrupt 96-127 Set Enable	143
0x110	EN4	R/W	0x0000.0000	Interrupt 128-138 Set Enable	144
0x180	DIS0	R/W	0x0000.0000	Interrupt 0-31 Clear Enable	145
0x184	DIS1	R/W	0x0000.0000	Interrupt 32-63 Clear Enable	145
0x188	DIS2	R/W	0x0000.0000	Interrupt 64-95 Clear Enable	145
0x18C	DIS3	R/W	0x0000.0000	Interrupt 96-127 Clear Enable	145
0x190	DIS4	R/W	0x0000.0000	Interrupt 128-138 Clear Enable	146
0x200	PEND0	R/W	0x0000.0000	Interrupt 0-31 Set Pending	147
0x204	PEND1	R/W	0x0000.0000	Interrupt 32-63 Set Pending	147

Table 3-8. Peripherals Register Map (continued)

Offset	Name	Type	Reset	Description	See page
0x208	PEND2	R/W	0x0000.0000	Interrupt 64-95 Set Pending	147
0x20C	PEND3	R/W	0x0000.0000	Interrupt 96-127 Set Pending	147
0x210	PEND4	R/W	0x0000.0000	Interrupt 128-138 Set Pending	148
0x280	UNPEND0	R/W	0x0000.0000	Interrupt 0-31 Clear Pending	149
0x284	UNPEND1	R/W	0x0000.0000	Interrupt 32-63 Clear Pending	149
0x288	UNPEND2	R/W	0x0000.0000	Interrupt 64-95 Clear Pending	149
0x28C	UNPEND3	R/W	0x0000.0000	Interrupt 96-127 Clear Pending	149
0x290	UNPEND4	R/W	0x0000.0000	Interrupt 128-138 Clear Pending	150
0x300	ACTIVE0	RO	0x0000.0000	Interrupt 0-31 Active Bit	151
0x304	ACTIVE1	RO	0x0000.0000	Interrupt 32-63 Active Bit	151
0x308	ACTIVE2	RO	0x0000.0000	Interrupt 64-95 Active Bit	151
0x30C	ACTIVE3	RO	0x0000.0000	Interrupt 96-127 Active Bit	151
0x310	ACTIVE4	RO	0x0000.0000	Interrupt 128-138 Active Bit	152
0x400	PRI0	R/W	0x0000.0000	Interrupt 0-3 Priority	153
0x404	PRI1	R/W	0x0000.0000	Interrupt 4-7 Priority	153
0x408	PRI2	R/W	0x0000.0000	Interrupt 8-11 Priority	153
0x40C	PRI3	R/W	0x0000.0000	Interrupt 12-15 Priority	153
0x410	PRI4	R/W	0x0000.0000	Interrupt 16-19 Priority	153
0x414	PRI5	R/W	0x0000.0000	Interrupt 20-23 Priority	153
0x418	PRI6	R/W	0x0000.0000	Interrupt 24-27 Priority	153
0x41C	PRI7	R/W	0x0000.0000	Interrupt 28-31 Priority	153
0x420	PRI8	R/W	0x0000.0000	Interrupt 32-35 Priority	153
0x424	PRI9	R/W	0x0000.0000	Interrupt 36-39 Priority	153
0x428	PRI10	R/W	0x0000.0000	Interrupt 40-43 Priority	153
0x42C	PRI11	R/W	0x0000.0000	Interrupt 44-47 Priority	153
0x430	PRI12	R/W	0x0000.0000	Interrupt 48-51 Priority	153
0x434	PRI13	R/W	0x0000.0000	Interrupt 52-55 Priority	153
0x438	PRI14	R/W	0x0000.0000	Interrupt 56-59 Priority	153
0x43C	PRI15	R/W	0x0000.0000	Interrupt 60-63 Priority	153
0x440	PRI16	R/W	0x0000.0000	Interrupt 64-67 Priority	155
0x444	PRI17	R/W	0x0000.0000	Interrupt 68-71 Priority	155
0x448	PRI18	R/W	0x0000.0000	Interrupt 72-75 Priority	155

Table 3-8. Peripherals Register Map (continued)

Offset	Name	Type	Reset	Description	See page
0x44C	PRI19	R/W	0x0000.0000	Interrupt 76-79 Priority	155
0x450	PRI20	R/W	0x0000.0000	Interrupt 80-83 Priority	155
0x454	PRI21	R/W	0x0000.0000	Interrupt 84-87 Priority	155
0x458	PRI22	R/W	0x0000.0000	Interrupt 88-91 Priority	155
0x45C	PRI23	R/W	0x0000.0000	Interrupt 92-95 Priority	155
0x460	PRI24	R/W	0x0000.0000	Interrupt 96-99 Priority	155
0x464	PRI25	R/W	0x0000.0000	Interrupt 100-103 Priority	155
0x468	PRI26	R/W	0x0000.0000	Interrupt 104-107 Priority	155
0x46C	PRI27	R/W	0x0000.0000	Interrupt 108-111 Priority	155
0x470	PRI28	R/W	0x0000.0000	Interrupt 112-115 Priority	155
0x474	PRI29	R/W	0x0000.0000	Interrupt 116-119 Priority	155
0x478	PRI30	R/W	0x0000.0000	Interrupt 120-123 Priority	155
0x47C	PRI31	R/W	0x0000.0000	Interrupt 124-127 Priority	155
0x480	PRI32	R/W	0x0000.0000	Interrupt 128-131 Priority	155
0x484	PRI33	R/W	0x0000.0000	Interrupt 132-135 Priority	155
0x488	PRI34	R/W	0x0000.0000	Interrupt 136-138 Priority	155
0xF00	SWTRIG	WO	0x0000.0000	Software Trigger Interrupt	157
System Control Block (SCB) Registers					
0x008	ACTLR	R/W	0x0000.0000	Auxiliary Control	158
0xD00	CPUID	RO	0x410F.C241	CPU ID Base	160
0xD04	INTCTRL	R/W	0x0000.0000	Interrupt Control and State	161
0xD08	VTABLE	R/W	0x0000.0000	Vector Table Offset	164
0xD0C	APINT	R/W	0xFA05.0000	Application Interrupt and Reset Control	165
0xD10	SYSCTRL	R/W	0x0000.0000	System Control	167
0xD14	CFGCTRL	R/W	0x0000.0200	Configuration and Control	169
0xD18	SYSPRI1	R/W	0x0000.0000	System Handler Priority 1	171
0xD1C	SYSPRI2	R/W	0x0000.0000	System Handler Priority 2	172
0xD20	SYSPRI3	R/W	0x0000.0000	System Handler Priority 3	173
0xD24	SYSHNDCTRL	R/W	0x0000.0000	System Handler Control and State	174
0xD28	FAULTSTAT	R/W1C	0x0000.0000	Configurable Fault Status	178
0xD2C	HFAULTSTAT	R/W1C	0x0000.0000	Hard Fault Status	184
0xD34	MMADDR	R/W	-	Memory Management Fault Address	185

Table 3-8. Peripherals Register Map (continued)

Offset	Name	Type	Reset	Description	See page
0xD38	FAULTADDR	R/W	-	Bus Fault Address	186
Memory Protection Unit (MPU) Registers					
0xD90	MPUTYPE	RO	0x0000.0800	MPU Type	187
0xD94	MPUCTRL	R/W	0x0000.0000	MPU Control	188
0xD98	MPUNUMBER	R/W	0x0000.0000	MPU Region Number	190
0xD9C	MPUBASE	R/W	0x0000.0000	MPU Region Base Address	191
0xDA0	MPUATTR	R/W	0x0000.0000	MPU Region Attribute and Size	193
0xDA4	MPUBASE1	R/W	0x0000.0000	MPU Region Base Address Alias 1	191
0xDA8	MPUATTR1	R/W	0x0000.0000	MPU Region Attribute and Size Alias 1	193
0xDAC	MPUBASE2	R/W	0x0000.0000	MPU Region Base Address Alias 2	191
0xDB0	MPUATTR2	R/W	0x0000.0000	MPU Region Attribute and Size Alias 2	193
0xDB4	MPUBASE3	R/W	0x0000.0000	MPU Region Base Address Alias 3	191
0xDB8	MPUATTR3	R/W	0x0000.0000	MPU Region Attribute and Size Alias 3	193
Floating-Point Unit (FPU) Registers					
0xD88	CPAC	R/W	0x0000.0000	Coprocessor Access Control	196
0xF34	FPCC	R/W	0xC000.0000	Floating-Point Context Control	197
0xF38	FPCA	R/W	-	Floating-Point Context Address	199
0xF3C	FPDSC	R/W	0x0000.0000	Floating-Point Default Status Control	200

3.3 System Timer (SysTick) Register Descriptions

This section lists and describes the System Timer registers, in numerical order by address offset.

Register 1: SysTick Control and Status Register (STCTRL), offset 0x010

Note: This register can only be accessed from privileged mode.

The SysTick **STCTRL** register enables the SysTick features.

SysTick Control and Status Register (STCTRL)

Base 0xE000.E000

Offset 0x010

Type R/W, reset 0x0000.0004

	31	30	29	28	27	26	25	24	23	22	21	20	19	18	17	16	
	reserved															COUNT	
Type	RO	RO	RO	RO	RO	RO	RO	RO	RO	RO	RO	RO	RO	RO	RO	RO	
Reset	0	0	0	0	0	0	0	0	0	0	0	0	0	0	0	0	
	15	14	13	12	11	10	9	8	7	6	5	4	3	2	1	0	
	reserved													CLK_SRC	INTEN	ENABLE	
Type	RO	RO	RO	RO	RO	RO	RO	RO	RO	RO	RO	RO	RO	RO	R/W	R/W	R/W
Reset	0	0	0	0	0	0	0	0	0	0	0	0	0	0	1	0	0

Bit/Field	Name	Type	Reset	Description						
31:17	reserved	RO	0x000	Software should not rely on the value of a reserved bit. To provide compatibility with future products, the value of a reserved bit should be preserved across a read-modify-write operation.						
16	COUNT	RO	0	Count Flag <table border="0"> <tr> <td>Value</td> <td>Description</td> </tr> <tr> <td>0</td> <td>The SysTick timer has not counted to 0 since the last time this bit was read.</td> </tr> <tr> <td>1</td> <td>The SysTick timer has counted to 0 since the last time this bit was read.</td> </tr> </table> <p>This bit is cleared by a read of the register or if the STCURRENT register is written with any value.</p> <p>If read by the debugger using the DAP, this bit is cleared only if the MasterType bit in the AHB-AP Control Register is clear. Otherwise, the COUNT bit is not changed by the debugger read. See the <i>ARM® Debug Interface V5 Architecture Specification</i> for more information on MasterType.</p>	Value	Description	0	The SysTick timer has not counted to 0 since the last time this bit was read.	1	The SysTick timer has counted to 0 since the last time this bit was read.
Value	Description									
0	The SysTick timer has not counted to 0 since the last time this bit was read.									
1	The SysTick timer has counted to 0 since the last time this bit was read.									
15:3	reserved	RO	0x000	Software should not rely on the value of a reserved bit. To provide compatibility with future products, the value of a reserved bit should be preserved across a read-modify-write operation.						
2	CLK_SRC	R/W	1	Clock Source <table border="0"> <tr> <td>Value</td> <td>Description</td> </tr> <tr> <td>0</td> <td>Precision internal oscillator (PIOSC) divided by 4</td> </tr> <tr> <td>1</td> <td>System clock</td> </tr> </table>	Value	Description	0	Precision internal oscillator (PIOSC) divided by 4	1	System clock
Value	Description									
0	Precision internal oscillator (PIOSC) divided by 4									
1	System clock									

Bit/Field	Name	Type	Reset	Description
1	INTEN	R/W	0	Interrupt Enable Value Description 0 Interrupt generation is disabled. Software can use the <code>COUNT</code> bit to determine if the counter has ever reached 0. 1 An interrupt is generated to the NVIC when SysTick counts to 0.
0	ENABLE	R/W	0	Enable Value Description 0 The counter is disabled. 1 Enables SysTick to operate in a multi-shot way. That is, the counter loads the <code>RELOAD</code> value and begins counting down. On reaching 0, the <code>COUNT</code> bit is set and an interrupt is generated if enabled by <code>INTEN</code> . The counter then loads the <code>RELOAD</code> value again and begins counting.

Register 2: SysTick Reload Value Register (STRELOAD), offset 0x014

Note: This register can only be accessed from privileged mode.

The **STRELOAD** register specifies the start value to load into the **SysTick Current Value (STCURRENT)** register when the counter reaches 0. The start value can be between 0x1 and 0x00FF.FFFF. A start value of 0 is possible but has no effect because the SysTick interrupt and the **COUNT** bit are activated when counting from 1 to 0.

SysTick can be configured as a multi-shot timer, repeated over and over, firing every N+1 clock pulses, where N is any value from 1 to 0x00FF.FFFF. For example, if a tick interrupt is required every 100 clock pulses, 99 must be written into the **RELOAD** field.

Note that in order to access this register correctly, the system clock must be faster than 8 MHz.

SysTick Reload Value Register (STRELOAD)

Base 0xE000.E000

Offset 0x014

Type R/W, reset -

	31	30	29	28	27	26	25	24	23	22	21	20	19	18	17	16
	reserved								RELOAD							
Type	RO	RO	RO	RO	RO	RO	RO	RO	R/W	R/W	R/W	R/W	R/W	R/W	R/W	R/W
Reset	0	0	0	0	0	0	0	0	0	0	0	0	0	0	0	0
	15	14	13	12	11	10	9	8	7	6	5	4	3	2	1	0
	RELOAD															
Type	R/W	R/W	R/W	R/W	R/W	R/W	R/W	R/W	R/W	R/W	R/W	R/W	R/W	R/W	R/W	R/W
Reset	0	0	0	0	0	0	0	0	0	0	0	0	0	0	0	0

Bit/Field	Name	Type	Reset	Description
31:24	reserved	RO	0x00	Software should not rely on the value of a reserved bit. To provide compatibility with future products, the value of a reserved bit should be preserved across a read-modify-write operation.
23:0	RELOAD	R/W	0x00.0000	Reload Value Value to load into the SysTick Current Value (STCURRENT) register when the counter reaches 0.

Register 3: SysTick Current Value Register (STCURRENT), offset 0x018

Note: This register can only be accessed from privileged mode.

The **STCURRENT** register contains the current value of the SysTick counter.

SysTick Current Value Register (STCURRENT)

Base 0xE000.E000

Offset 0x018

Type R/WC, reset -

	31	30	29	28	27	26	25	24	23	22	21	20	19	18	17	16
	reserved								CURRENT							
Type	RO	RO	RO	RO	RO	RO	RO	RO	R/WC	R/WC	R/WC	R/WC	R/WC	R/WC	R/WC	R/WC
Reset	0	0	0	0	0	0	0	0	0	0	0	0	0	0	0	0
	15	14	13	12	11	10	9	8	7	6	5	4	3	2	1	0
	CURRENT															
Type	R/WC	R/WC	R/WC	R/WC	R/WC	R/WC	R/WC	R/WC	R/WC	R/WC	R/WC	R/WC	R/WC	R/WC	R/WC	R/WC
Reset	0	0	0	0	0	0	0	0	0	0	0	0	0	0	0	0

Bit/Field	Name	Type	Reset	Description
31:24	reserved	RO	0x00	Software should not rely on the value of a reserved bit. To provide compatibility with future products, the value of a reserved bit should be preserved across a read-modify-write operation.
23:0	CURRENT	R/WC	0x00.0000	Current Value This field contains the current value at the time the register is accessed. No read-modify-write protection is provided, so change with care. This register is write-clear. Writing to it with any value clears the register. Clearing this register also clears the <code>COUNT</code> bit of the STCTRL register.

3.4 NVIC Register Descriptions

This section lists and describes the NVIC registers, in numerical order by address offset.

The NVIC registers can only be fully accessed from privileged mode, but interrupts can be pended while in unprivileged mode by enabling the **Configuration and Control (CFGCTRL)** register. Any other unprivileged mode access causes a bus fault.

Ensure software uses correctly aligned register accesses. The processor does not support unaligned accesses to NVIC registers.

An interrupt can enter the pending state even if it is disabled.

Before programming the **VTABLE** register to relocate the vector table, ensure the vector table entries of the new vector table are set up for fault handlers, NMI, and all enabled exceptions such as interrupts. For more information, see page 164.

Register 4: Interrupt 0-31 Set Enable (EN0), offset 0x100**Register 5: Interrupt 32-63 Set Enable (EN1), offset 0x104****Register 6: Interrupt 64-95 Set Enable (EN2), offset 0x108****Register 7: Interrupt 96-127 Set Enable (EN3), offset 0x10C**

Note: This register can only be accessed from privileged mode.

The **ENn** registers enable interrupts and show which interrupts are enabled. Bit 0 of **EN0** corresponds to Interrupt 0; bit 31 corresponds to Interrupt 31. Bit 0 of **EN1** corresponds to Interrupt 32; bit 31 corresponds to Interrupt 63. Bit 0 of **EN2** corresponds to Interrupt 64; bit 31 corresponds to Interrupt 95. Bit 0 of **EN3** corresponds to Interrupt 96; bit 31 corresponds to Interrupt 127. Bit 0 of **EN4** (see page 144) corresponds to Interrupt 128; bit 10 corresponds to Interrupt 138.

See Table 2-9 on page 105 for interrupt assignments.

If a pending interrupt is enabled, the NVIC activates the interrupt based on its priority. If an interrupt is not enabled, asserting its interrupt signal changes the interrupt state to pending, but the NVIC never activates the interrupt, regardless of its priority.

Interrupt 0-31 Set Enable (EN0)

Base 0xE000.E000

Offset 0x100

Type R/W, reset 0x0000.0000

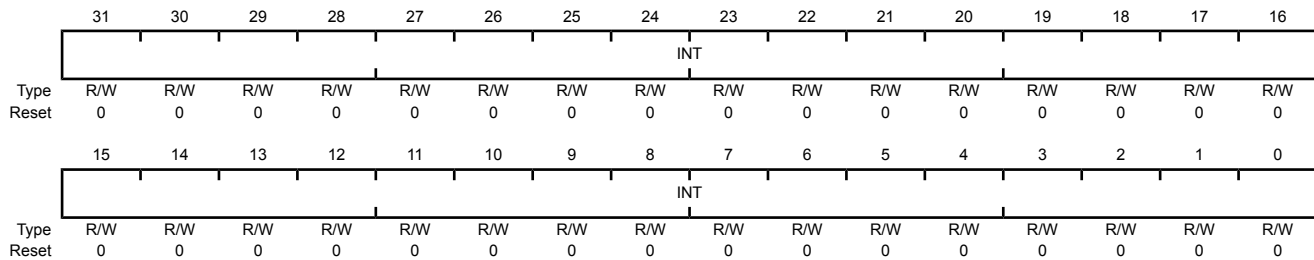

Bit/Field	Name	Type	Reset	Description
31:0	INT	R/W	0x0000.0000	Interrupt Enable

Value	Description
0	On a read, indicates the interrupt is disabled. On a write, no effect.
1	On a read, indicates the interrupt is enabled. On a write, enables the interrupt.

A bit can only be cleared by setting the corresponding `INT[n]` bit in the **DISn** register.

Register 8: Interrupt 128-138 Set Enable (EN4), offset 0x110

Note: This register can only be accessed from privileged mode.

The **EN4** register enables interrupts and shows which interrupts are enabled. Bit 0 corresponds to Interrupt 128; bit 10 corresponds to Interrupt 138. See Table 2-9 on page 105 for interrupt assignments.

If a pending interrupt is enabled, the NVIC activates the interrupt based on its priority. If an interrupt is not enabled, asserting its interrupt signal changes the interrupt state to pending, but the NVIC never activates the interrupt, regardless of its priority.

Interrupt 128-138 Set Enable (EN4)

Base 0xE000.E000

Offset 0x110

Type R/W, reset 0x0000.0000

	31	30	29	28	27	26	25	24	23	22	21	20	19	18	17	16
	reserved															
Type	RO	RO	RO	RO	RO	RO	RO	RO	RO	RO	RO	RO	RO	RO	RO	RO
Reset	0	0	0	0	0	0	0	0	0	0	0	0	0	0	0	0
	15	14	13	12	11	10	9	8	7	6	5	4	3	2	1	0
	reserved					INT										
Type	RO	RO	RO	RO	RO	R/W	R/W	R/W	R/W	R/W	R/W	R/W	R/W	R/W	R/W	R/W
Reset	0	0	0	0	0	0	0	0	0	0	0	0	0	0	0	0

Bit/Field	Name	Type	Reset	Description						
31:11	reserved	RO	0x0000.000	Software should not rely on the value of a reserved bit. To provide compatibility with future products, the value of a reserved bit should be preserved across a read-modify-write operation.						
10:0	INT	R/W	0x0	Interrupt Enable						
				<table border="1"> <thead> <tr> <th>Value</th> <th>Description</th> </tr> </thead> <tbody> <tr> <td>0</td> <td>On a read, indicates the interrupt is disabled. On a write, no effect.</td> </tr> <tr> <td>1</td> <td>On a read, indicates the interrupt is enabled. On a write, enables the interrupt.</td> </tr> </tbody> </table>	Value	Description	0	On a read, indicates the interrupt is disabled. On a write, no effect.	1	On a read, indicates the interrupt is enabled. On a write, enables the interrupt.
Value	Description									
0	On a read, indicates the interrupt is disabled. On a write, no effect.									
1	On a read, indicates the interrupt is enabled. On a write, enables the interrupt.									

A bit can only be cleared by setting the corresponding `INT[n]` bit in the **DIS4** register.

Register 9: Interrupt 0-31 Clear Enable (DIS0), offset 0x180**Register 10: Interrupt 32-63 Clear Enable (DIS1), offset 0x184****Register 11: Interrupt 64-95 Clear Enable (DIS2), offset 0x188****Register 12: Interrupt 96-127 Clear Enable (DIS3), offset 0x18C**

Note: This register can only be accessed from privileged mode.

The **DIS_n** registers disable interrupts. Bit 0 of **DIS0** corresponds to Interrupt 0; bit 31 corresponds to Interrupt 31. Bit 0 of **DIS1** corresponds to Interrupt 32; bit 31 corresponds to Interrupt 63. Bit 0 of **DIS2** corresponds to Interrupt 64; bit 31 corresponds to Interrupt 95. Bit 0 of **DIS3** corresponds to Interrupt 96; bit 31 corresponds to Interrupt 127. Bit 0 of **DIS4** (see page 146) corresponds to Interrupt 128; bit 10 corresponds to Interrupt 138.

See Table 2-9 on page 105 for interrupt assignments.

Interrupt 0-31 Clear Enable (DIS0)

Base 0xE000.E000

Offset 0x180

Type R/W, reset 0x0000.0000

	31	30	29	28	27	26	25	24	23	22	21	20	19	18	17	16
	INT															
Type	R/W	R/W	R/W	R/W	R/W	R/W	R/W	R/W	R/W	R/W	R/W	R/W	R/W	R/W	R/W	R/W
Reset	0	0	0	0	0	0	0	0	0	0	0	0	0	0	0	0
	15	14	13	12	11	10	9	8	7	6	5	4	3	2	1	0
	INT															
Type	R/W	R/W	R/W	R/W	R/W	R/W	R/W	R/W	R/W	R/W	R/W	R/W	R/W	R/W	R/W	R/W
Reset	0	0	0	0	0	0	0	0	0	0	0	0	0	0	0	0

Bit/Field	Name	Type	Reset	Description
31:0	INT	R/W	0x0000.0000	Interrupt Disable

Value Description

0 On a read, indicates the interrupt is disabled.

On a write, no effect.

1 On a read, indicates the interrupt is enabled.

On a write, clears the corresponding **INT**[n] bit in the **EN0** register, disabling interrupt [n].

Register 13: Interrupt 128-138 Clear Enable (DIS4), offset 0x190

Note: This register can only be accessed from privileged mode.

The **DIS4** register disables interrupts. Bit 0 corresponds to Interrupt 128; bit 10 corresponds to Interrupt 138. See Table 2-9 on page 105 for interrupt assignments.

Interrupt 128-138 Clear Enable (DIS4)

Base 0xE000.E000

Offset 0x190

Type R/W, reset 0x0000.0000

	31	30	29	28	27	26	25	24	23	22	21	20	19	18	17	16
	reserved															
Type	RO	RO	RO	RO	RO	RO	RO	RO	RO	RO	RO	RO	RO	RO	RO	RO
Reset	0	0	0	0	0	0	0	0	0	0	0	0	0	0	0	0
	15	14	13	12	11	10	9	8	7	6	5	4	3	2	1	0
	reserved					INT										
Type	RO	RO	RO	RO	RO	R/W	R/W	R/W	R/W	R/W	R/W	R/W	R/W	R/W	R/W	R/W
Reset	0	0	0	0	0	0	0	0	0	0	0	0	0	0	0	0

Bit/Field	Name	Type	Reset	Description
31:11	reserved	RO	0x0000.000	Software should not rely on the value of a reserved bit. To provide compatibility with future products, the value of a reserved bit should be preserved across a read-modify-write operation.
10:0	INT	R/W	0x0	Interrupt Disable

Value Description

0 On a read, indicates the interrupt is disabled.

On a write, no effect.

1 On a read, indicates the interrupt is enabled.

On a write, clears the corresponding `INT[n]` bit in the **EN4** register, disabling interrupt [n].

Register 14: Interrupt 0-31 Set Pending (PEND0), offset 0x200

Register 15: Interrupt 32-63 Set Pending (PEND1), offset 0x204

Register 16: Interrupt 64-95 Set Pending (PEND2), offset 0x208

Register 17: Interrupt 96-127 Set Pending (PEND3), offset 0x20C

Note: This register can only be accessed from privileged mode.

The **PEND_n** registers force interrupts into the pending state and show which interrupts are pending. Bit 0 of **PEND0** corresponds to Interrupt 0; bit 31 corresponds to Interrupt 31. Bit 0 of **PEND1** corresponds to Interrupt 32; bit 31 corresponds to Interrupt 63. Bit 0 of **PEND2** corresponds to Interrupt 64; bit 31 corresponds to Interrupt 95. Bit 0 of **PEND3** corresponds to Interrupt 96; bit 31 corresponds to Interrupt 127. Bit 0 of **PEND4** (see page 148) corresponds to Interrupt 128; bit 10 corresponds to Interrupt 138.

See Table 2-9 on page 105 for interrupt assignments.

Interrupt 0-31 Set Pending (PEND0)

Base 0xE000.E000
Offset 0x200
Type R/W, reset 0x0000.0000

	31	30	29	28	27	26	25	24	23	22	21	20	19	18	17	16
	INT															
Type	R/W	R/W	R/W	R/W	R/W	R/W	R/W	R/W	R/W	R/W	R/W	R/W	R/W	R/W	R/W	R/W
Reset	0	0	0	0	0	0	0	0	0	0	0	0	0	0	0	0
	15	14	13	12	11	10	9	8	7	6	5	4	3	2	1	0
	INT															
Type	R/W	R/W	R/W	R/W	R/W	R/W	R/W	R/W	R/W	R/W	R/W	R/W	R/W	R/W	R/W	R/W
Reset	0	0	0	0	0	0	0	0	0	0	0	0	0	0	0	0

Bit/Field	Name	Type	Reset	Description
31:0	INT	R/W	0x0000.0000	Interrupt Set Pending
				Value Description
				0 On a read, indicates that the interrupt is not pending. On a write, no effect.
				1 On a read, indicates that the interrupt is pending. On a write, the corresponding interrupt is set to pending even if it is disabled.
				If the corresponding interrupt is already pending, setting a bit has no effect.
				A bit can only be cleared by setting the corresponding <code>INT[n]</code> bit in the UNPEND0 register.

Register 18: Interrupt 128-138 Set Pending (PEND4), offset 0x210

Note: This register can only be accessed from privileged mode.

The **PEND4** register forces interrupts into the pending state and shows which interrupts are pending. Bit 0 corresponds to Interrupt 128; bit 10 corresponds to Interrupt 138. See Table 2-9 on page 105 for interrupt assignments.

Interrupt 128-138 Set Pending (PEND4)

Base 0xE000.E000

Offset 0x210

Type R/W, reset 0x0000.0000

	31	30	29	28	27	26	25	24	23	22	21	20	19	18	17	16
	reserved															
Type	RO	RO	RO	RO	RO	RO	RO	RO	RO	RO	RO	RO	RO	RO	RO	RO
Reset	0	0	0	0	0	0	0	0	0	0	0	0	0	0	0	0
	15	14	13	12	11	10	9	8	7	6	5	4	3	2	1	0
	reserved					INT										
Type	RO	RO	RO	RO	RO	R/W	R/W	R/W	R/W	R/W	R/W	R/W	R/W	R/W	R/W	R/W
Reset	0	0	0	0	0	0	0	0	0	0	0	0	0	0	0	0

Bit/Field	Name	Type	Reset	Description
31:11	reserved	RO	0x0000.000	Software should not rely on the value of a reserved bit. To provide compatibility with future products, the value of a reserved bit should be preserved across a read-modify-write operation.
10:0	INT	R/W	0x0	Interrupt Set Pending

Value	Description
0	On a read, indicates that the interrupt is not pending. On a write, no effect.
1	On a read, indicates that the interrupt is pending. On a write, the corresponding interrupt is set to pending even if it is disabled.

If the corresponding interrupt is already pending, setting a bit has no effect.

A bit can only be cleared by setting the corresponding `INT[n]` bit in the **UNPEND4** register.

Register 19: Interrupt 0-31 Clear Pending (UNPEND0), offset 0x280

Register 20: Interrupt 32-63 Clear Pending (UNPEND1), offset 0x284

Register 21: Interrupt 64-95 Clear Pending (UNPEND2), offset 0x288

Register 22: Interrupt 96-127 Clear Pending (UNPEND3), offset 0x28C

Note: This register can only be accessed from privileged mode.

The **UNPEND_n** registers show which interrupts are pending and remove the pending state from interrupts. Bit 0 of **UNPEND0** corresponds to Interrupt 0; bit 31 corresponds to Interrupt 31. Bit 0 of **UNPEND1** corresponds to Interrupt 32; bit 31 corresponds to Interrupt 63. Bit 0 of **UNPEND2** corresponds to Interrupt 64; bit 31 corresponds to Interrupt 95. Bit 0 of **UNPEND3** corresponds to Interrupt 96; bit 31 corresponds to Interrupt 127. Bit 0 of **UNPEND4** (see page 150) corresponds to Interrupt 128; bit 10 corresponds to Interrupt 138.

See Table 2-9 on page 105 for interrupt assignments.

Interrupt 0-31 Clear Pending (UNPEND0)

Base 0xE000.E000
Offset 0x280
Type R/W, reset 0x0000.0000

	31	30	29	28	27	26	25	24	23	22	21	20	19	18	17	16
	INT															
Type	R/W	R/W	R/W	R/W	R/W	R/W	R/W	R/W	R/W	R/W	R/W	R/W	R/W	R/W	R/W	R/W
Reset	0	0	0	0	0	0	0	0	0	0	0	0	0	0	0	0
	15	14	13	12	11	10	9	8	7	6	5	4	3	2	1	0
	INT															
Type	R/W	R/W	R/W	R/W	R/W	R/W	R/W	R/W	R/W	R/W	R/W	R/W	R/W	R/W	R/W	R/W
Reset	0	0	0	0	0	0	0	0	0	0	0	0	0	0	0	0

Bit/Field	Name	Type	Reset	Description
31:0	INT	R/W	0x0000.0000	Interrupt Clear Pending

Value Description

0 On a read, indicates that the interrupt is not pending.
On a write, no effect.

1 On a read, indicates that the interrupt is pending.
On a write, clears the corresponding **INT[n]** bit in the **PEND0** register, so that interrupt [n] is no longer pending.
Setting a bit does not affect the active state of the corresponding interrupt.

Register 23: Interrupt 128-138 Clear Pending (UNPEND4), offset 0x290

Note: This register can only be accessed from privileged mode.

The **UNPEND4** register shows which interrupts are pending and removes the pending state from interrupts. Bit 0 corresponds to Interrupt 128; bit 10 corresponds to Interrupt 138. See Table 2-9 on page 105 for interrupt assignments.

Interrupt 128-138 Clear Pending (UNPEND4)

Base 0xE000.E000

Offset 0x290

Type R/W, reset 0x0000.0000

	31	30	29	28	27	26	25	24	23	22	21	20	19	18	17	16
	reserved															
Type	RO	RO	RO	RO	RO	RO	RO	RO	RO	RO	RO	RO	RO	RO	RO	RO
Reset	0	0	0	0	0	0	0	0	0	0	0	0	0	0	0	0
	15	14	13	12	11	10	9	8	7	6	5	4	3	2	1	0
	reserved					INT										
Type	RO	RO	RO	RO	RO	R/W	R/W	R/W	R/W	R/W	R/W	R/W	R/W	R/W	R/W	R/W
Reset	0	0	0	0	0	0	0	0	0	0	0	0	0	0	0	0

Bit/Field	Name	Type	Reset	Description
31:11	reserved	RO	0x0000.000	Software should not rely on the value of a reserved bit. To provide compatibility with future products, the value of a reserved bit should be preserved across a read-modify-write operation.
10:0	INT	R/W	0x0	Interrupt Clear Pending

Value Description

0 On a read, indicates that the interrupt is not pending.
On a write, no effect.

1 On a read, indicates that the interrupt is pending.
On a write, clears the corresponding `INT[n]` bit in the **PEND4** register, so that interrupt [n] is no longer pending.
Setting a bit does not affect the active state of the corresponding interrupt.

Register 24: Interrupt 0-31 Active Bit (ACTIVE0), offset 0x300

Register 25: Interrupt 32-63 Active Bit (ACTIVE1), offset 0x304

Register 26: Interrupt 64-95 Active Bit (ACTIVE2), offset 0x308

Register 27: Interrupt 96-127 Active Bit (ACTIVE3), offset 0x30C

Note: This register can only be accessed from privileged mode.

The **UNPEND_n** registers indicate which interrupts are active. Bit 0 of **ACTIVE0** corresponds to Interrupt 0; bit 31 corresponds to Interrupt 31. Bit 0 of **ACTIVE1** corresponds to Interrupt 32; bit 31 corresponds to Interrupt 63. Bit 0 of **ACTIVE2** corresponds to Interrupt 64; bit 31 corresponds to Interrupt 95. Bit 0 of **ACTIVE3** corresponds to Interrupt 96; bit 31 corresponds to Interrupt 127. Bit 0 of **ACTIVE4** (see page 152) corresponds to Interrupt 128; bit 10 corresponds to Interrupt 138.

See Table 2-9 on page 105 for interrupt assignments.

Caution – Do not manually set or clear the bits in this register.

Interrupt 0-31 Active Bit (ACTIVE0)

Base 0xE000.E000

Offset 0x300

Type RO, reset 0x0000.0000

	31	30	29	28	27	26	25	24	23	22	21	20	19	18	17	16
	INT															
Type	RO	RO	RO	RO	RO	RO	RO	RO	RO	RO	RO	RO	RO	RO	RO	RO
Reset	0	0	0	0	0	0	0	0	0	0	0	0	0	0	0	0
	15	14	13	12	11	10	9	8	7	6	5	4	3	2	1	0
	INT															
Type	RO	RO	RO	RO	RO	RO	RO	RO	RO	RO	RO	RO	RO	RO	RO	RO
Reset	0	0	0	0	0	0	0	0	0	0	0	0	0	0	0	0

Bit/Field	Name	Type	Reset	Description
31:0	INT	RO	0x0000.0000	Interrupt Active

Value Description

Value	Description
0	The corresponding interrupt is not active.
1	The corresponding interrupt is active, or active and pending.

Register 28: Interrupt 128-138 Active Bit (ACTIVE4), offset 0x310

Note: This register can only be accessed from privileged mode.

The **ACTIVE4** register indicates which interrupts are active. Bit 0 corresponds to Interrupt 128; bit 10 corresponds to Interrupt 131. See Table 2-9 on page 105 for interrupt assignments.

Caution – Do not manually set or clear the bits in this register.

Interrupt 128-138 Active Bit (ACTIVE4)

Base 0xE000.E000

Offset 0x310

Type RO, reset 0x0000.0000

	31	30	29	28	27	26	25	24	23	22	21	20	19	18	17	16
	reserved															
Type	RO	RO	RO	RO	RO	RO	RO	RO	RO	RO	RO	RO	RO	RO	RO	RO
Reset	0	0	0	0	0	0	0	0	0	0	0	0	0	0	0	0
	15	14	13	12	11	10	9	8	7	6	5	4	3	2	1	0
	reserved					INT										
Type	RO	RO	RO	RO	RO	RO	RO	RO	RO	RO	RO	RO	RO	RO	RO	RO
Reset	0	0	0	0	0	0	0	0	0	0	0	0	0	0	0	0

Bit/Field	Name	Type	Reset	Description
31:11	reserved	RO	0x0000.000	Software should not rely on the value of a reserved bit. To provide compatibility with future products, the value of a reserved bit should be preserved across a read-modify-write operation.
10:0	INT	RO	0x0	Interrupt Active
				Value Description
				0 The corresponding interrupt is not active.
				1 The corresponding interrupt is active, or active and pending.

- Register 29: Interrupt 0-3 Priority (PRI0), offset 0x400**
Register 30: Interrupt 4-7 Priority (PRI1), offset 0x404
Register 31: Interrupt 8-11 Priority (PRI2), offset 0x408
Register 32: Interrupt 12-15 Priority (PRI3), offset 0x40C
Register 33: Interrupt 16-19 Priority (PRI4), offset 0x410
Register 34: Interrupt 20-23 Priority (PRI5), offset 0x414
Register 35: Interrupt 24-27 Priority (PRI6), offset 0x418
Register 36: Interrupt 28-31 Priority (PRI7), offset 0x41C
Register 37: Interrupt 32-35 Priority (PRI8), offset 0x420
Register 38: Interrupt 36-39 Priority (PRI9), offset 0x424
Register 39: Interrupt 40-43 Priority (PRI10), offset 0x428
Register 40: Interrupt 44-47 Priority (PRI11), offset 0x42C
Register 41: Interrupt 48-51 Priority (PRI12), offset 0x430
Register 42: Interrupt 52-55 Priority (PRI13), offset 0x434
Register 43: Interrupt 56-59 Priority (PRI14), offset 0x438
Register 44: Interrupt 60-63 Priority (PRI15), offset 0x43C

Note: This register can only be accessed from privileged mode.

The **PRI_n** registers (see also page 155) provide 3-bit priority fields for each interrupt. These registers are byte accessible. Each register holds four priority fields that are assigned to interrupts as follows:

PRI_n Register Bit Field	Interrupt
Bits 31:29	Interrupt [4n+3]
Bits 23:21	Interrupt [4n+2]
Bits 15:13	Interrupt [4n+1]
Bits 7:5	Interrupt [4n]

See Table 2-9 on page 105 for interrupt assignments.

Each priority level can be split into separate group priority and subpriority fields. The **PRI_{GROUP}** field in the **Application Interrupt and Reset Control (APINT)** register (see page 165) indicates the position of the binary point that splits the priority and subpriority fields.

These registers can only be accessed from privileged mode.

Interrupt 0-3 Priority (PRIO)

Base 0xE000.E000

Offset 0x400

Type R/W, reset 0x0000.0000

	31	30	29	28	27	26	25	24	23	22	21	20	19	18	17	16
	INTD			reserved				INTC			reserved					
Type	R/W	R/W	R/W	RO	RO	RO	RO	RO	R/W	R/W	R/W	RO	RO	RO	RO	RO
Reset	0	0	0	0	0	0	0	0	0	0	0	0	0	0	0	0
	15	14	13	12	11	10	9	8	7	6	5	4	3	2	1	0
	INTB			reserved				INTA			reserved					
Type	R/W	R/W	R/W	RO	RO	RO	RO	RO	R/W	R/W	R/W	RO	RO	RO	RO	RO
Reset	0	0	0	0	0	0	0	0	0	0	0	0	0	0	0	0

Bit/Field	Name	Type	Reset	Description
31:29	INTD	R/W	0x0	Interrupt Priority for Interrupt [4n+3] This field holds a priority value, 0-7, for the interrupt with the number [4n+3], where n is the number of the Interrupt Priority register (n=0 for PRIO , and so on). The lower the value, the greater the priority of the corresponding interrupt.
28:24	reserved	RO	0x0	Software should not rely on the value of a reserved bit. To provide compatibility with future products, the value of a reserved bit should be preserved across a read-modify-write operation.
23:21	INTC	R/W	0x0	Interrupt Priority for Interrupt [4n+2] This field holds a priority value, 0-7, for the interrupt with the number [4n+2], where n is the number of the Interrupt Priority register (n=0 for PRIO , and so on). The lower the value, the greater the priority of the corresponding interrupt.
20:16	reserved	RO	0x0	Software should not rely on the value of a reserved bit. To provide compatibility with future products, the value of a reserved bit should be preserved across a read-modify-write operation.
15:13	INTB	R/W	0x0	Interrupt Priority for Interrupt [4n+1] This field holds a priority value, 0-7, for the interrupt with the number [4n+1], where n is the number of the Interrupt Priority register (n=0 for PRIO , and so on). The lower the value, the greater the priority of the corresponding interrupt.
12:8	reserved	RO	0x0	Software should not rely on the value of a reserved bit. To provide compatibility with future products, the value of a reserved bit should be preserved across a read-modify-write operation.
7:5	INTA	R/W	0x0	Interrupt Priority for Interrupt [4n] This field holds a priority value, 0-7, for the interrupt with the number [4n], where n is the number of the Interrupt Priority register (n=0 for PRIO , and so on). The lower the value, the greater the priority of the corresponding interrupt.
4:0	reserved	RO	0x0	Software should not rely on the value of a reserved bit. To provide compatibility with future products, the value of a reserved bit should be preserved across a read-modify-write operation.

Register 45: Interrupt 64-67 Priority (PRI16), offset 0x440
Register 46: Interrupt 68-71 Priority (PRI17), offset 0x444
Register 47: Interrupt 72-75 Priority (PRI18), offset 0x448
Register 48: Interrupt 76-79 Priority (PRI19), offset 0x44C
Register 49: Interrupt 80-83 Priority (PRI20), offset 0x450
Register 50: Interrupt 84-87 Priority (PRI21), offset 0x454
Register 51: Interrupt 88-91 Priority (PRI22), offset 0x458
Register 52: Interrupt 92-95 Priority (PRI23), offset 0x45C
Register 53: Interrupt 96-99 Priority (PRI24), offset 0x460
Register 54: Interrupt 100-103 Priority (PRI25), offset 0x464
Register 55: Interrupt 104-107 Priority (PRI26), offset 0x468
Register 56: Interrupt 108-111 Priority (PRI27), offset 0x46C
Register 57: Interrupt 112-115 Priority (PRI28), offset 0x470
Register 58: Interrupt 116-119 Priority (PRI29), offset 0x474
Register 59: Interrupt 120-123 Priority (PRI30), offset 0x478
Register 60: Interrupt 124-127 Priority (PRI31), offset 0x47C
Register 61: Interrupt 128-131 Priority (PRI32), offset 0x480
Register 62: Interrupt 132-135 Priority (PRI33), offset 0x484
Register 63: Interrupt 136-138 Priority (PRI34), offset 0x488

Note: This register can only be accessed from privileged mode.

The **PRIn** registers (see also page 153) provide 3-bit priority fields for each interrupt. These registers are byte accessible. Each register holds four priority fields that are assigned to interrupts as follows:

PRIn Register Bit Field	Interrupt
Bits 31:29	Interrupt [4n+3]
Bits 23:21	Interrupt [4n+2]
Bits 15:13	Interrupt [4n+1]
Bits 7:5	Interrupt [4n]

See Table 2-9 on page 105 for interrupt assignments.

Each priority level can be split into separate group priority and subpriority fields. The **PRIGROUP** field in the **Application Interrupt and Reset Control (APINT)** register (see page 165) indicates the position of the binary point that splits the priority and subpriority fields .

These registers can only be accessed from privileged mode.

Interrupt 64-67 Priority (PRI16)

Base 0xE000.E000

Offset 0x440

Type R/W, reset 0x0000.0000

	31	30	29	28	27	26	25	24	23	22	21	20	19	18	17	16
	INTD			reserved				INTC			reserved					
Type	R/W	R/W	R/W	RO	RO	RO	RO	RO	R/W	R/W	R/W	RO	RO	RO	RO	RO
Reset	0	0	0	0	0	0	0	0	0	0	0	0	0	0	0	0
	15	14	13	12	11	10	9	8	7	6	5	4	3	2	1	0
	INTB			reserved				INTA			reserved					
Type	R/W	R/W	R/W	RO	RO	RO	RO	RO	R/W	R/W	R/W	RO	RO	RO	RO	RO
Reset	0	0	0	0	0	0	0	0	0	0	0	0	0	0	0	0

Bit/Field	Name	Type	Reset	Description
31:29	INTD	R/W	0x0	Interrupt Priority for Interrupt [4n+3] This field holds a priority value, 0-7, for the interrupt with the number [4n+3], where n is the number of the Interrupt Priority register (n=0 for PRI0 , and so on). The lower the value, the greater the priority of the corresponding interrupt.
28:24	reserved	RO	0x0	Software should not rely on the value of a reserved bit. To provide compatibility with future products, the value of a reserved bit should be preserved across a read-modify-write operation.
23:21	INTC	R/W	0x0	Interrupt Priority for Interrupt [4n+2] This field holds a priority value, 0-7, for the interrupt with the number [4n+2], where n is the number of the Interrupt Priority register (n=0 for PRI0 , and so on). The lower the value, the greater the priority of the corresponding interrupt.
20:16	reserved	RO	0x0	Software should not rely on the value of a reserved bit. To provide compatibility with future products, the value of a reserved bit should be preserved across a read-modify-write operation.
15:13	INTB	R/W	0x0	Interrupt Priority for Interrupt [4n+1] This field holds a priority value, 0-7, for the interrupt with the number [4n+1], where n is the number of the Interrupt Priority register (n=0 for PRI0 , and so on). The lower the value, the greater the priority of the corresponding interrupt.
12:8	reserved	RO	0x0	Software should not rely on the value of a reserved bit. To provide compatibility with future products, the value of a reserved bit should be preserved across a read-modify-write operation.
7:5	INTA	R/W	0x0	Interrupt Priority for Interrupt [4n] This field holds a priority value, 0-7, for the interrupt with the number [4n], where n is the number of the Interrupt Priority register (n=0 for PRI0 , and so on). The lower the value, the greater the priority of the corresponding interrupt.
4:0	reserved	RO	0x0	Software should not rely on the value of a reserved bit. To provide compatibility with future products, the value of a reserved bit should be preserved across a read-modify-write operation.

Register 64: Software Trigger Interrupt (SWTRIG), offset 0xF00

Note: Only privileged software can enable unprivileged access to the **SWTRIG** register.

Writing an interrupt number to the **SWTRIG** register generates a Software Generated Interrupt (SGI). See Table 2-9 on page 105 for interrupt assignments.

When the **MAINPEND** bit in the **Configuration and Control (CFGCTRL)** register (see page 169) is set, unprivileged software can access the **SWTRIG** register.

Software Trigger Interrupt (SWTRIG)

Base 0xE000.E000
Offset 0xF00
Type WO, reset 0x0000.0000

	31	30	29	28	27	26	25	24	23	22	21	20	19	18	17	16
	reserved															
Type	RO	RO	RO	RO	RO	RO	RO	RO	RO	RO	RO	RO	RO	RO	RO	RO
Reset	0	0	0	0	0	0	0	0	0	0	0	0	0	0	0	0
	15	14	13	12	11	10	9	8	7	6	5	4	3	2	1	0
	reserved								INTID							
Type	RO	RO	RO	RO	RO	RO	RO	RO	WO	WO	WO	WO	WO	WO	WO	WO
Reset	0	0	0	0	0	0	0	0	0	0	0	0	0	0	0	0

Bit/Field	Name	Type	Reset	Description
31:8	reserved	RO	0x0000.00	Software should not rely on the value of a reserved bit. To provide compatibility with future products, the value of a reserved bit should be preserved across a read-modify-write operation.
7:0	INTID	WO	0x00	Interrupt ID This field holds the interrupt ID of the required SGI. For example, a value of 0x3 generates an interrupt on IRQ3.

3.5 System Control Block (SCB) Register Descriptions

This section lists and describes the System Control Block (SCB) registers, in numerical order by address offset. The SCB registers can only be accessed from privileged mode.

All registers must be accessed with aligned word accesses except for the **FAULTSTAT** and **SYSPRI1-SYSPRI3** registers, which can be accessed with byte or aligned halfword or word accesses. The processor does not support unaligned accesses to system control block registers.

Register 65: Auxiliary Control (ACTLR), offset 0x008

Note: This register can only be accessed from privileged mode.

The **ACTLR** register provides disable bits for **IT** folding, write buffer use for accesses to the default memory map, and interruption of multi-cycle instructions. By default, this register is set to provide optimum performance from the Cortex-M4 processor and does not normally require modification.

Auxiliary Control (ACTLR)

Base 0xE000.E000

Offset 0x008

Type R/W, reset 0x0000.0000

	31	30	29	28	27	26	25	24	23	22	21	20	19	18	17	16
	reserved															
Type	RO	RO	RO	RO	RO	RO	RO	RO	RO	RO	RO	RO	RO	RO	RO	RO
Reset	0	0	0	0	0	0	0	0	0	0	0	0	0	0	0	0
	15	14	13	12	11	10	9	8	7	6	5	4	3	2	1	0
	reserved						DISOOF	DISFPCA	reserved					DISFOLD	DISWBUF	DISMCYC
Type	RO	RO	RO	RO	RO	RO	R/W	R/W	RO	RO	RO	RO	RO	R/W	R/W	R/W
Reset	0	0	0	0	0	0	0	0	0	0	0	0	0	0	0	0

Bit/Field	Name	Type	Reset	Description
31:10	reserved	RO	0x00	Software should not rely on the value of a reserved bit. To provide compatibility with future products, the value of a reserved bit should be preserved across a read-modify-write operation.
9	DISOOF	R/W	0	Disable Out-Of-Order Floating Point Disables floating-point instructions completing out of order with respect to integer instructions.
8	DISFPCA	R/W	0	Disable CONTROL.FPCA Disable automatic update of the FPCA bit in the CONTROL register.
<p>Important: Two bits control when FPCA can be enabled: the ASPEN bit in the Floating-Point Context Control (FPCC) register and the DISFPCA bit in the Auxiliary Control (ACTLR) register.</p>				
7:3	reserved	RO	0x00	Software should not rely on the value of a reserved bit. To provide compatibility with future products, the value of a reserved bit should be preserved across a read-modify-write operation.
2	DISFOLD	R/W	0	Disable IT Folding
	Value	Description		
	0	No effect.		
	1	Disables IT folding.		

In some situations, the processor can start executing the first instruction in an **IT** block while it is still executing the **IT** instruction. This behavior is called *IT folding*, and improves performance. However, **IT** folding can cause jitter in looping. If a task must avoid jitter, set the **DISFOLD** bit before executing the task, to disable **IT** folding.

Bit/Field	Name	Type	Reset	Description
1	DISWBUF	R/W	0	<p>Disable Write Buffer</p> <p>Value Description</p> <p>0 No effect.</p> <p>1 Disables write buffer use during default memory map accesses. In this situation, all bus faults are precise bus faults but performance is decreased because any store to memory must complete before the processor can execute the next instruction.</p> <p>Note: This bit only affects write buffers implemented in the Cortex-M4 processor.</p>
0	DISMCYC	R/W	0	<p>Disable Interrupts of Multiple Cycle Instructions</p> <p>Value Description</p> <p>0 No effect.</p> <p>1 Disables interruption of load multiple and store multiple instructions. In this situation, the interrupt latency of the processor is increased because any LDM or STM must complete before the processor can stack the current state and enter the interrupt handler.</p>

Register 66: CPU ID Base (CPUID), offset 0xD00

Note: This register can only be accessed from privileged mode.

The **CPUID** register contains the ARM® Cortex™-M4 processor part number, version, and implementation information.

CPU ID Base (CPUID)

Base 0xE000.E000

Offset 0xD00

Type RO, reset 0x410F.C241

	31	30	29	28	27	26	25	24	23	22	21	20	19	18	17	16
	IMP								VAR				CON			
Type	RO	RO	RO	RO	RO	RO	RO	RO	RO	RO	RO	RO	RO	RO	RO	RO
Reset	0	1	0	0	0	0	0	1	0	0	0	0	1	1	1	1
	15	14	13	12	11	10	9	8	7	6	5	4	3	2	1	0
	PARTNO												REV			
Type	RO	RO	RO	RO	RO	RO	RO	RO	RO	RO	RO	RO	RO	RO	RO	RO
Reset	1	1	0	0	0	0	1	0	0	1	0	0	0	0	0	1

Bit/Field	Name	Type	Reset	Description
31:24	IMP	RO	0x41	Implementer Code Value Description 0x41 ARM
23:20	VAR	RO	0x0	Variant Number Value Description 0x0 The rn value in the mpn product revision identifier, for example, the 0 in r0p0.
19:16	CON	RO	0xF	Constant Value Description 0xF Always reads as 0xF.
15:4	PARTNO	RO	0xC24	Part Number Value Description 0xC24 Cortex-M4 processor.
3:0	REV	RO	0x1	Revision Number Value Description 0x1 The pn value in the mpn product revision identifier, for example, the 1 in r0p1.

Register 67: Interrupt Control and State (INTCTRL), offset 0xD04

Note: This register can only be accessed from privileged mode.

The **INCTRL** register provides a set-pending bit for the NMI exception, and set-pending and clear-pending bits for the PendSV and SysTick exceptions. In addition, bits in this register indicate the exception number of the exception being processed, whether there are preempted active exceptions, the exception number of the highest priority pending exception, and whether any interrupts are pending.

When writing to **INCTRL**, the effect is unpredictable when writing a 1 to both the **PENDSV** and **UNPENDSV** bits, or writing a 1 to both the **PENDSTSET** and **PENDSTCLR** bits.

Interrupt Control and State (INTCTRL)

Base 0xE000.E000

Offset 0xD04

Type R/W, reset 0x0000.0000

	31	30	29	28	27	26	25	24	23	22	21	20	19	18	17	16
	NMISSET	reserved		PENDSV	UNPENDSV	PENDSTSET	PENDSTCLR	reserved	ISRPRE	ISRPEND	reserved		VECPEND			
Type	R/W	RO	RO	R/W	WO	R/W	WO	RO	RO	RO	RO	RO	RO	RO	RO	RO
Reset	0	0	0	0	0	0	0	0	0	0	0	0	0	0	0	0
	15	14	13	12	11	10	9	8	7	6	5	4	3	2	1	0
	VECPEND				RETBASE	reserved			VECACT							
Type	RO	RO	RO	RO	RO	RO	RO	RO	RO	RO	RO	RO	RO	RO	RO	RO
Reset	0	0	0	0	0	0	0	0	0	0	0	0	0	0	0	0

Bit/Field	Name	Type	Reset	Description
-----------	------	------	-------	-------------

31	NMISSET	R/W	0	NMI Set Pending
----	---------	-----	---	-----------------

Value Description

0	On a read, indicates an NMI exception is not pending. On a write, no effect.
---	---

1	On a read, indicates an NMI exception is pending. On a write, changes the NMI exception state to pending.
---	--

Because NMI is the highest-priority exception, normally the processor enters the NMI exception handler as soon as it registers the setting of this bit, and clears this bit on entering the interrupt handler. A read of this bit by the NMI exception handler returns 1 only if the **NMI** signal is reasserted while the processor is executing that handler.

30:29	reserved	RO	0x0	Software should not rely on the value of a reserved bit. To provide compatibility with future products, the value of a reserved bit should be preserved across a read-modify-write operation.
-------	----------	----	-----	---

28	PENDSV	R/W	0	PendSV Set Pending
----	--------	-----	---	--------------------

Value Description

0	On a read, indicates a PendSV exception is not pending. On a write, no effect.
---	---

1	On a read, indicates a PendSV exception is pending. On a write, changes the PendSV exception state to pending.
---	---

Setting this bit is the only way to set the PendSV exception state to pending. This bit is cleared by writing a 1 to the **UNPENDSV** bit.

Bit/Field	Name	Type	Reset	Description
27	UNPENDSV	WO	0	<p>PendSV Clear Pending</p> <p>Value Description</p> <p>0 On a write, no effect.</p> <p>1 On a write, removes the pending state from the PendSV exception.</p> <p>This bit is write only; on a register read, its value is unknown.</p>
26	PENDSTSET	R/W	0	<p>SysTick Set Pending</p> <p>Value Description</p> <p>0 On a read, indicates a SysTick exception is not pending. On a write, no effect.</p> <p>1 On a read, indicates a SysTick exception is pending. On a write, changes the SysTick exception state to pending.</p> <p>This bit is cleared by writing a 1 to the PENDSTCLR bit.</p>
25	PENDSTCLR	WO	0	<p>SysTick Clear Pending</p> <p>Value Description</p> <p>0 On a write, no effect.</p> <p>1 On a write, removes the pending state from the SysTick exception.</p> <p>This bit is write only; on a register read, its value is unknown.</p>
24	reserved	RO	0	Software should not rely on the value of a reserved bit. To provide compatibility with future products, the value of a reserved bit should be preserved across a read-modify-write operation.
23	ISRPRE	RO	0	<p>Debug Interrupt Handling</p> <p>Value Description</p> <p>0 The release from halt does not take an interrupt.</p> <p>1 The release from halt takes an interrupt.</p> <p>This bit is only meaningful in Debug mode and reads as zero when the processor is not in Debug mode.</p>
22	ISRPEND	RO	0	<p>Interrupt Pending</p> <p>Value Description</p> <p>0 No interrupt is pending.</p> <p>1 An interrupt is pending.</p> <p>This bit provides status for all interrupts excluding NMI and Faults.</p>
21:20	reserved	RO	0x0	Software should not rely on the value of a reserved bit. To provide compatibility with future products, the value of a reserved bit should be preserved across a read-modify-write operation.

Bit/Field	Name	Type	Reset	Description																																						
19:12	VECPEND	RO	0x00	<p>Interrupt Pending Vector Number</p> <p>This field contains the exception number of the highest priority pending enabled exception. The value indicated by this field includes the effect of the BASEPRI and FAULTMASK registers, but not any effect of the PRIMASK register.</p> <table border="1"> <thead> <tr> <th>Value</th> <th>Description</th> </tr> </thead> <tbody> <tr><td>0x00</td><td>No exceptions are pending</td></tr> <tr><td>0x01</td><td>Reserved</td></tr> <tr><td>0x02</td><td>NMI</td></tr> <tr><td>0x03</td><td>Hard fault</td></tr> <tr><td>0x04</td><td>Memory management fault</td></tr> <tr><td>0x05</td><td>Bus fault</td></tr> <tr><td>0x06</td><td>Usage fault</td></tr> <tr><td>0x07-0x0A</td><td>Reserved</td></tr> <tr><td>0x0B</td><td>SVCall</td></tr> <tr><td>0x0C</td><td>Reserved for Debug</td></tr> <tr><td>0x0D</td><td>Reserved</td></tr> <tr><td>0x0E</td><td>PendSV</td></tr> <tr><td>0x0F</td><td>SysTick</td></tr> <tr><td>0x10</td><td>Interrupt Vector 0</td></tr> <tr><td>0x11</td><td>Interrupt Vector 1</td></tr> <tr><td>...</td><td>...</td></tr> <tr><td>0x9A</td><td>Interrupt Vector 138</td></tr> <tr><td>0x94-0x7F</td><td>Reserved</td></tr> </tbody> </table>	Value	Description	0x00	No exceptions are pending	0x01	Reserved	0x02	NMI	0x03	Hard fault	0x04	Memory management fault	0x05	Bus fault	0x06	Usage fault	0x07-0x0A	Reserved	0x0B	SVCall	0x0C	Reserved for Debug	0x0D	Reserved	0x0E	PendSV	0x0F	SysTick	0x10	Interrupt Vector 0	0x11	Interrupt Vector 1	0x9A	Interrupt Vector 138	0x94-0x7F	Reserved
Value	Description																																									
0x00	No exceptions are pending																																									
0x01	Reserved																																									
0x02	NMI																																									
0x03	Hard fault																																									
0x04	Memory management fault																																									
0x05	Bus fault																																									
0x06	Usage fault																																									
0x07-0x0A	Reserved																																									
0x0B	SVCall																																									
0x0C	Reserved for Debug																																									
0x0D	Reserved																																									
0x0E	PendSV																																									
0x0F	SysTick																																									
0x10	Interrupt Vector 0																																									
0x11	Interrupt Vector 1																																									
...	...																																									
0x9A	Interrupt Vector 138																																									
0x94-0x7F	Reserved																																									
11	RETBASE	RO	0	<p>Return to Base</p> <table border="1"> <thead> <tr> <th>Value</th> <th>Description</th> </tr> </thead> <tbody> <tr><td>0</td><td>There are preempted active exceptions to execute.</td></tr> <tr><td>1</td><td>There are no active exceptions, or the currently executing exception is the only active exception.</td></tr> </tbody> </table> <p>This bit provides status for all interrupts excluding NMI and Faults. This bit only has meaning if the processor is currently executing an ISR (the Interrupt Program Status (IPSR) register is non-zero).</p>	Value	Description	0	There are preempted active exceptions to execute.	1	There are no active exceptions, or the currently executing exception is the only active exception.																																
Value	Description																																									
0	There are preempted active exceptions to execute.																																									
1	There are no active exceptions, or the currently executing exception is the only active exception.																																									
10:8	reserved	RO	0x0	Software should not rely on the value of a reserved bit. To provide compatibility with future products, the value of a reserved bit should be preserved across a read-modify-write operation.																																						
7:0	VECACT	RO	0x00	<p>Interrupt Pending Vector Number</p> <p>This field contains the active exception number. The exception numbers can be found in the description for the VECPEND field. If this field is clear, the processor is in Thread mode. This field contains the same value as the ISRNUM field in the IPSR register.</p> <p>Subtract 16 from this value to obtain the IRQ number required to index into the Interrupt Set Enable (ENn), Interrupt Clear Enable (DISn), Interrupt Set Pending (PENDn), Interrupt Clear Pending (UNPENDn), and Interrupt Priority (PRIn) registers (see page 82).</p>																																						

Register 68: Vector Table Offset (VTABLE), offset 0xD08

Note: This register can only be accessed from privileged mode.

The **VTABLE** register indicates the offset of the vector table base address from memory address 0x0000.0000.

Vector Table Offset (VTABLE)

Base 0xE000.E000

Offset 0xD08

Type R/W, reset 0x0000.0000

	31	30	29	28	27	26	25	24	23	22	21	20	19	18	17	16
	reserved		BASE	OFFSET												
Type	RO	RO	R/W	R/W	R/W	R/W	R/W	R/W	R/W	R/W	R/W	R/W	R/W	R/W	R/W	R/W
Reset	0	0	0	0	0	0	0	0	0	0	0	0	0	0	0	0
	15	14	13	12	11	10	9	8	7	6	5	4	3	2	1	0
	OFFSET						reserved									
Type	R/W	R/W	R/W	R/W	R/W	R/W	RO	RO	RO	RO	RO	RO	RO	RO	RO	RO
Reset	0	0	0	0	0	0	0	0	0	0	0	0	0	0	0	0

Bit/Field	Name	Type	Reset	Description
31:30	reserved	RO	0x0	Software should not rely on the value of a reserved bit. To provide compatibility with future products, the value of a reserved bit should be preserved across a read-modify-write operation.
29	BASE	R/W	0	Vector Table Base Value Description 0 The vector table is in the code memory region. 1 The vector table is in the SRAM memory region.
28:10	OFFSET	R/W	0x000.00	Vector Table Offset When configuring the <i>OFFSET</i> field, the offset must be aligned to the number of exception entries in the vector table. Because there are 138 interrupts, the offset must be aligned on a 1024-byte boundary.
9:0	reserved	RO	0x00	Software should not rely on the value of a reserved bit. To provide compatibility with future products, the value of a reserved bit should be preserved across a read-modify-write operation.

Register 69: Application Interrupt and Reset Control (APINT), offset 0xD0C

Note: This register can only be accessed from privileged mode.

The **APINT** register provides priority grouping control for the exception model, endian status for data accesses, and reset control of the system. To write to this register, 0x05FA must be written to the **VECTKEY** field, otherwise the write is ignored.

The **PRIGROUP** field indicates the position of the binary point that splits the **INTx** fields in the **Interrupt Priority (PRIx)** registers into separate group priority and subpriority fields. Table 3-9 on page 165 shows how the **PRIGROUP** value controls this split. The bit numbers in the Group Priority Field and Subpriority Field columns in the table refer to the bits in the **INTA** field. For the **INTB** field, the corresponding bits are 15:13; for **INTC**, 23:21; and for **INTD**, 31:29.

Note: Determining preemption of an exception uses only the group priority field.

Table 3-9. Interrupt Priority Levels

PRIGROUP Bit Field	Binary Point ^a	Group Priority Field	Subpriority Field	Group Priorities	Subpriorities
0x0 - 0x4	bxxx.	[7:5]	None	8	1
0x5	bxx.y	[7:6]	[5]	4	2
0x6	bx.yy	[7]	[6:5]	2	4
0x7	b.yyy	None	[7:5]	1	8

a. **INTx** field showing the binary point. An x denotes a group priority field bit, and a y denotes a subpriority field bit.

Application Interrupt and Reset Control (APINT)

Base 0xE000.E000

Offset 0xD0C

Type R/W, reset 0xFA05.0000

	31	30	29	28	27	26	25	24	23	22	21	20	19	18	17	16
	VECTKEY															
Type	R/W	R/W	R/W	R/W	R/W	R/W	R/W	R/W	R/W	R/W	R/W	R/W	R/W	R/W	R/W	R/W
Reset	1	1	1	1	1	0	1	0	0	0	0	0	0	1	0	1
	15	14	13	12	11	10	9	8	7	6	5	4	3	2	1	0
	ENDIANESS	reserved				PRIGROUP				reserved				SYSRESREQ	VECTLRACT	VECTRESET
Type	RO	RO	RO	RO	RO	R/W	R/W	R/W	RO	RO	RO	RO	RO	RO	WO	WO
Reset	0	0	0	0	0	0	0	0	0	0	0	0	0	0	0	0

Bit/Field	Name	Type	Reset	Description
31:16	VECTKEY	R/W	0xFA05	Register Key This field is used to guard against accidental writes to this register. 0x05FA must be written to this field in order to change the bits in this register. On a read, 0xFA05 is returned.
15	ENDIANESS	RO	0	Data Endianess The Stellaris implementation uses only little-endian mode so this is cleared to 0.
14:11	reserved	RO	0x0	Software should not rely on the value of a reserved bit. To provide compatibility with future products, the value of a reserved bit should be preserved across a read-modify-write operation.

Bit/Field	Name	Type	Reset	Description
10:8	PRIGROUP	R/W	0x0	Interrupt Priority Grouping This field determines the split of group priority from subpriority (see Table 3-9 on page 165 for more information).
7:3	reserved	RO	0x0	Software should not rely on the value of a reserved bit. To provide compatibility with future products, the value of a reserved bit should be preserved across a read-modify-write operation.
2	SYSRESREQ	WO	0	System Reset Request Value Description 0 No effect. 1 Resets the core and all on-chip peripherals except the Debug interface. This bit is automatically cleared during the reset of the core and reads as 0.
1	VECTCLRACT	WO	0	Clear Active NMI / Fault This bit is reserved for Debug use and reads as 0. This bit must be written as a 0, otherwise behavior is unpredictable.
0	VECTRESET	WO	0	System Reset This bit is reserved for Debug use and reads as 0. This bit must be written as a 0, otherwise behavior is unpredictable.

Register 70: System Control (SYSCTRL), offset 0xD10**Note:** This register can only be accessed from privileged mode.The **SYSCTRL** register controls features of entry to and exit from low-power state.

System Control (SYSCTRL)

Base 0xE000.E000

Offset 0xD10

Type R/W, reset 0x0000.0000

	31	30	29	28	27	26	25	24	23	22	21	20	19	18	17	16	
	reserved																
Type	RO	RO	RO	RO	RO	RO	RO	RO	RO	RO	RO	RO	RO	RO	RO	RO	
Reset	0	0	0	0	0	0	0	0	0	0	0	0	0	0	0	0	
	15	14	13	12	11	10	9	8	7	6	5	4	3	2	1	0	
	reserved												SEVONPEND	reserved	SLEEPDEEP	SLEEPEXIT	reserved
Type	RO	RO	RO	RO	RO	RO	RO	RO	RO	RO	RO	RO	R/W	RO	R/W	R/W	RO
Reset	0	0	0	0	0	0	0	0	0	0	0	0	0	0	0	0	0

Bit/Field	Name	Type	Reset	Description
31:5	reserved	RO	0x0000.00	Software should not rely on the value of a reserved bit. To provide compatibility with future products, the value of a reserved bit should be preserved across a read-modify-write operation.
4	SEVONPEND	R/W	0	Wake Up on Pending Value Description 0 Only enabled interrupts or events can wake up the processor; disabled interrupts are excluded. 1 Enabled events and all interrupts, including disabled interrupts, can wake up the processor. When an event or interrupt enters the pending state, the event signal wakes up the processor from <i>WFE</i> . If the processor is not waiting for an event, the event is registered and affects the next <i>WFE</i> . The processor also wakes up on execution of a <i>SEV</i> instruction or an external event.
3	reserved	RO	0	Software should not rely on the value of a reserved bit. To provide compatibility with future products, the value of a reserved bit should be preserved across a read-modify-write operation.
2	SLEEPDEEP	R/W	0	Deep Sleep Enable Value Description 0 Use Sleep mode as the low power mode. 1 Use Deep-sleep mode as the low power mode.

Bit/Field	Name	Type	Reset	Description
1	SLEEPEXIT	R/W	0	Sleep on ISR Exit Value Description 0 When returning from Handler mode to Thread mode, do not sleep when returning to Thread mode. 1 When returning from Handler mode to Thread mode, enter sleep or deep sleep on return from an ISR. Setting this bit enables an interrupt-driven application to avoid returning to an empty main application.
0	reserved	RO	0	Software should not rely on the value of a reserved bit. To provide compatibility with future products, the value of a reserved bit should be preserved across a read-modify-write operation.

Register 71: Configuration and Control (CFGCTRL), offset 0xD14

Note: This register can only be accessed from privileged mode.

The **CFGCTRL** register controls entry to Thread mode and enables: the handlers for NMI, hard fault and faults escalated by the **FAULTMASK** register to ignore bus faults; trapping of divide by zero and unaligned accesses; and access to the **SWTRIG** register by unprivileged software (see page 157).

Configuration and Control (CFGCTRL)

Base 0xE000.E000

Offset 0xD14

Type R/W, reset 0x0000.0200

	31	30	29	28	27	26	25	24	23	22	21	20	19	18	17	16	
	reserved																
Type	RO	RO	RO	RO	RO	RO	RO	RO	RO	RO	RO	RO	RO	RO	RO	RO	
Reset	0	0	0	0	0	0	0	0	0	0	0	0	0	0	0	0	
	15	14	13	12	11	10	9	8	7	6	5	4	3	2	1	0	
	reserved						STKALIGN	BFHFNMIGN	reserved				DIV0	UNALIGNED	reserved	MAINPEND	BASETHR
Type	RO	RO	RO	RO	RO	RO	R/W	R/W	RO	RO	RO	R/W	R/W	RO	R/W	R/W	
Reset	0	0	0	0	0	0	1	0	0	0	0	0	0	0	0	0	

Bit/Field	Name	Type	Reset	Description
31:10	reserved	RO	0x0000.00	Software should not rely on the value of a reserved bit. To provide compatibility with future products, the value of a reserved bit should be preserved across a read-modify-write operation.
9	STKALIGN	R/W	1	Stack Alignment on Exception Entry Value Description 0 The stack is 4-byte aligned. 1 The stack is 8-byte aligned. On exception entry, the processor uses bit 9 of the stacked PSR to indicate the stack alignment. On return from the exception, it uses this stacked bit to restore the correct stack alignment.
8	BFHFNMIGN	R/W	0	Ignore Bus Fault in NMI and Fault This bit enables handlers with priority -1 or -2 to ignore data bus faults caused by load and store instructions. The setting of this bit applies to the hard fault, NMI, and FAULTMASK escalated handlers. Value Description 0 Data bus faults caused by load and store instructions cause a lock-up. 1 Handlers running at priority -1 and -2 ignore data bus faults caused by load and store instructions. Set this bit only when the handler and its data are in absolutely safe memory. The normal use of this bit is to probe system devices and bridges to detect control path problems and fix them.
7:5	reserved	RO	0x0	Software should not rely on the value of a reserved bit. To provide compatibility with future products, the value of a reserved bit should be preserved across a read-modify-write operation.

Bit/Field	Name	Type	Reset	Description
4	DIV0	R/W	0	<p>Trap on Divide by 0</p> <p>This bit enables faulting or halting when the processor executes an <code>SDIV</code> or <code>UDIV</code> instruction with a divisor of 0.</p> <p>Value Description</p> <p>0 Do not trap on divide by 0. A divide by zero returns a quotient of 0.</p> <p>1 Trap on divide by 0.</p>
3	UNALIGNED	R/W	0	<p>Trap on Unaligned Access</p> <p>Value Description</p> <p>0 Do not trap on unaligned halfword and word accesses.</p> <p>1 Trap on unaligned halfword and word accesses. An unaligned access generates a usage fault.</p> <p>Unaligned <code>LDM</code>, <code>STM</code>, <code>LDRD</code>, and <code>STRD</code> instructions always fault regardless of whether <code>UNALIGNED</code> is set.</p>
2	reserved	RO	0	Software should not rely on the value of a reserved bit. To provide compatibility with future products, the value of a reserved bit should be preserved across a read-modify-write operation.
1	MAINPEND	R/W	0	<p>Allow Main Interrupt Trigger</p> <p>Value Description</p> <p>0 Disables unprivileged software access to the SWTRIG register.</p> <p>1 Enables unprivileged software access to the SWTRIG register (see page 157).</p>
0	BASETHR	R/W	0	<p>Thread State Control</p> <p>Value Description</p> <p>0 The processor can enter Thread mode only when no exception is active.</p> <p>1 The processor can enter Thread mode from any level under the control of an <code>EXC_RETURN</code> value (see "Exception Return" on page 111 for more information).</p>

Register 72: System Handler Priority 1 (SYSPRI1), offset 0xD18

Note: This register can only be accessed from privileged mode.

The **SYSPRI1** register configures the priority level, 0 to 7 of the usage fault, bus fault, and memory management fault exception handlers. This register is byte-accessible.

System Handler Priority 1 (SYSPRI1)

Base 0xE000.E000

Offset 0xD18

Type R/W, reset 0x0000.0000

	31	30	29	28	27	26	25	24	23	22	21	20	19	18	17	16
	reserved								USAGE			reserved				
Type	RO	RO	RO	RO	RO	RO	RO	RO	R/W	R/W	R/W	RO	RO	RO	RO	RO
Reset	0	0	0	0	0	0	0	0	0	0	0	0	0	0	0	0
	15	14	13	12	11	10	9	8	7	6	5	4	3	2	1	0
	BUS			reserved					MEM			reserved				
Type	R/W	R/W	R/W	RO	RO	RO	RO	RO	R/W	R/W	R/W	RO	RO	RO	RO	RO
Reset	0	0	0	0	0	0	0	0	0	0	0	0	0	0	0	0

Bit/Field	Name	Type	Reset	Description
31:24	reserved	RO	0x00	Software should not rely on the value of a reserved bit. To provide compatibility with future products, the value of a reserved bit should be preserved across a read-modify-write operation.
23:21	USAGE	R/W	0x0	Usage Fault Priority This field configures the priority level of the usage fault. Configurable priority values are in the range 0-7, with lower values having higher priority.
20:16	reserved	RO	0x0	Software should not rely on the value of a reserved bit. To provide compatibility with future products, the value of a reserved bit should be preserved across a read-modify-write operation.
15:13	BUS	R/W	0x0	Bus Fault Priority This field configures the priority level of the bus fault. Configurable priority values are in the range 0-7, with lower values having higher priority.
12:8	reserved	RO	0x0	Software should not rely on the value of a reserved bit. To provide compatibility with future products, the value of a reserved bit should be preserved across a read-modify-write operation.
7:5	MEM	R/W	0x0	Memory Management Fault Priority This field configures the priority level of the memory management fault. Configurable priority values are in the range 0-7, with lower values having higher priority.
4:0	reserved	RO	0x0	Software should not rely on the value of a reserved bit. To provide compatibility with future products, the value of a reserved bit should be preserved across a read-modify-write operation.

Register 73: System Handler Priority 2 (SYSPRI2), offset 0xD1C

Note: This register can only be accessed from privileged mode.

The **SYSPRI2** register configures the priority level, 0 to 7 of the SVCcall handler. This register is byte-accessible.

System Handler Priority 2 (SYSPRI2)

Base 0xE000.E000
 Offset 0xD1C
 Type R/W, reset 0x0000.0000

	31	30	29	28	27	26	25	24	23	22	21	20	19	18	17	16
	SVC			reserved												
Type	R/W	R/W	R/W	RO	RO	RO	RO	RO	RO	RO	RO	RO	RO	RO	RO	RO
Reset	0	0	0	0	0	0	0	0	0	0	0	0	0	0	0	0
	15	14	13	12	11	10	9	8	7	6	5	4	3	2	1	0
	reserved															
Type	RO	RO	RO	RO	RO	RO	RO	RO	RO	RO	RO	RO	RO	RO	RO	RO
Reset	0	0	0	0	0	0	0	0	0	0	0	0	0	0	0	0

Bit/Field	Name	Type	Reset	Description
31:29	SVC	R/W	0x0	SVCcall Priority This field configures the priority level of SVCcall. Configurable priority values are in the range 0-7, with lower values having higher priority.
28:0	reserved	RO	0x000.0000	Software should not rely on the value of a reserved bit. To provide compatibility with future products, the value of a reserved bit should be preserved across a read-modify-write operation.

Register 74: System Handler Priority 3 (SYSPRI3), offset 0xD20

Note: This register can only be accessed from privileged mode.

The **SYSPRI3** register configures the priority level, 0 to 7 of the SysTick exception and PendSV handlers. This register is byte-accessible.

System Handler Priority 3 (SYSPRI3)

Base 0xE000.E000

Offset 0xD20

Type R/W, reset 0x0000.0000

	31	30	29	28	27	26	25	24	23	22	21	20	19	18	17	16
	TICK			reserved					PENDSV			reserved				
Type	R/W	R/W	R/W	RO	RO	RO	RO	RO	R/W	R/W	R/W	RO	RO	RO	RO	RO
Reset	0	0	0	0	0	0	0	0	0	0	0	0	0	0	0	0
	15	14	13	12	11	10	9	8	7	6	5	4	3	2	1	0
	reserved								DEBUG			reserved				
Type	RO	RO	RO	RO	RO	RO	RO	RO	R/W	R/W	R/W	RO	RO	RO	RO	RO
Reset	0	0	0	0	0	0	0	0	0	0	0	0	0	0	0	0

Bit/Field	Name	Type	Reset	Description
31:29	TICK	R/W	0x0	SysTick Exception Priority This field configures the priority level of the SysTick exception. Configurable priority values are in the range 0-7, with lower values having higher priority.
28:24	reserved	RO	0x0	Software should not rely on the value of a reserved bit. To provide compatibility with future products, the value of a reserved bit should be preserved across a read-modify-write operation.
23:21	PENDSV	R/W	0x0	PendSV Priority This field configures the priority level of PendSV. Configurable priority values are in the range 0-7, with lower values having higher priority.
20:8	reserved	RO	0x000	Software should not rely on the value of a reserved bit. To provide compatibility with future products, the value of a reserved bit should be preserved across a read-modify-write operation.
7:5	DEBUG	R/W	0x0	Debug Priority This field configures the priority level of Debug. Configurable priority values are in the range 0-7, with lower values having higher priority.
4:0	reserved	RO	0x0.0000	Software should not rely on the value of a reserved bit. To provide compatibility with future products, the value of a reserved bit should be preserved across a read-modify-write operation.

Register 75: System Handler Control and State (SYSHNDCTRL), offset 0xD24

Note: This register can only be accessed from privileged mode.

The **SYSHNDCTRL** register enables the system handlers, and indicates the pending status of the usage fault, bus fault, memory management fault, and SVC exceptions as well as the active status of the system handlers.

If a system handler is disabled and the corresponding fault occurs, the processor treats the fault as a hard fault.

This register can be modified to change the pending or active status of system exceptions. An OS kernel can write to the active bits to perform a context switch that changes the current exception type.

Caution – Software that changes the value of an active bit in this register without correct adjustment to the stacked content can cause the processor to generate a fault exception. Ensure software that writes to this register retains and subsequently restores the current active status.

If the value of a bit in this register must be modified after enabling the system handlers, a read-modify-write procedure must be used to ensure that only the required bit is modified.

System Handler Control and State (SYSHNDCTRL)

Base 0xE000.E000

Offset 0xD24

Type R/W, reset 0x0000.0000

	31	30	29	28	27	26	25	24	23	22	21	20	19	18	17	16
	reserved													USAGE	BUS	MEM
Type	RO	RO	RO	RO	RO	RO	RO	RO	RO	RO	RO	RO	RO	R/W	R/W	R/W
Reset	0	0	0	0	0	0	0	0	0	0	0	0	0	0	0	0
	15	14	13	12	11	10	9	8	7	6	5	4	3	2	1	0
	SVC	BUSP	MEMP	USAGEP	TICK	PNDSV	reserved	MON	SVCA	reserved			USGA	reserved	BUSA	MEMA
Type	R/W	R/W	R/W	R/W	R/W	R/W	RO	R/W	R/W	RO	RO	RO	R/W	RO	R/W	R/W
Reset	0	0	0	0	0	0	0	0	0	0	0	0	0	0	0	0

Bit/Field	Name	Type	Reset	Description
31:19	reserved	RO	0x000	Software should not rely on the value of a reserved bit. To provide compatibility with future products, the value of a reserved bit should be preserved across a read-modify-write operation.
18	USAGE	R/W	0	Usage Fault Enable Value Description 0 Disables the usage fault exception. 1 Enables the usage fault exception.
17	BUS	R/W	0	Bus Fault Enable Value Description 0 Disables the bus fault exception. 1 Enables the bus fault exception.

Bit/Field	Name	Type	Reset	Description
16	MEM	R/W	0	<p>Memory Management Fault Enable</p> <p>Value Description</p> <p>0 Disables the memory management fault exception.</p> <p>1 Enables the memory management fault exception.</p>
15	SVC	R/W	0	<p>SVC Call Pending</p> <p>Value Description</p> <p>0 An SVC call exception is not pending.</p> <p>1 An SVC call exception is pending.</p> <p>This bit can be modified to change the pending status of the SVC call exception.</p>
14	BUSP	R/W	0	<p>Bus Fault Pending</p> <p>Value Description</p> <p>0 A bus fault exception is not pending.</p> <p>1 A bus fault exception is pending.</p> <p>This bit can be modified to change the pending status of the bus fault exception.</p>
13	MEMP	R/W	0	<p>Memory Management Fault Pending</p> <p>Value Description</p> <p>0 A memory management fault exception is not pending.</p> <p>1 A memory management fault exception is pending.</p> <p>This bit can be modified to change the pending status of the memory management fault exception.</p>
12	USAGEP	R/W	0	<p>Usage Fault Pending</p> <p>Value Description</p> <p>0 A usage fault exception is not pending.</p> <p>1 A usage fault exception is pending.</p> <p>This bit can be modified to change the pending status of the usage fault exception.</p>
11	TICK	R/W	0	<p>SysTick Exception Active</p> <p>Value Description</p> <p>0 A SysTick exception is not active.</p> <p>1 A SysTick exception is active.</p> <p>This bit can be modified to change the active status of the SysTick exception, however, see the Caution above before setting this bit.</p>

Bit/Field	Name	Type	Reset	Description
10	PND SV	R/W	0	<p>PendSV Exception Active</p> <p>Value Description</p> <p>0 A PendSV exception is not active.</p> <p>1 A PendSV exception is active.</p> <p>This bit can be modified to change the active status of the PendSV exception, however, see the Caution above before setting this bit.</p>
9	reserved	RO	0	Software should not rely on the value of a reserved bit. To provide compatibility with future products, the value of a reserved bit should be preserved across a read-modify-write operation.
8	MON	R/W	0	<p>Debug Monitor Active</p> <p>Value Description</p> <p>0 The Debug monitor is not active.</p> <p>1 The Debug monitor is active.</p>
7	SVCA	R/W	0	<p>SVC Call Active</p> <p>Value Description</p> <p>0 SVC call is not active.</p> <p>1 SVC call is active.</p> <p>This bit can be modified to change the active status of the SVC call exception, however, see the Caution above before setting this bit.</p>
6:4	reserved	RO	0x0	Software should not rely on the value of a reserved bit. To provide compatibility with future products, the value of a reserved bit should be preserved across a read-modify-write operation.
3	USGA	R/W	0	<p>Usage Fault Active</p> <p>Value Description</p> <p>0 Usage fault is not active.</p> <p>1 Usage fault is active.</p> <p>This bit can be modified to change the active status of the usage fault exception, however, see the Caution above before setting this bit.</p>
2	reserved	RO	0	Software should not rely on the value of a reserved bit. To provide compatibility with future products, the value of a reserved bit should be preserved across a read-modify-write operation.
1	BUSA	R/W	0	<p>Bus Fault Active</p> <p>Value Description</p> <p>0 Bus fault is not active.</p> <p>1 Bus fault is active.</p> <p>This bit can be modified to change the active status of the bus fault exception, however, see the Caution above before setting this bit.</p>

Bit/Field	Name	Type	Reset	Description
0	MEMA	R/W	0	Memory Management Fault Active
				Value Description
				0 Memory management fault is not active.
				1 Memory management fault is active.
				This bit can be modified to change the active status of the memory management fault exception, however, see the Caution above before setting this bit.

Register 76: Configurable Fault Status (FAULTSTAT), offset 0xD28

Note: This register can only be accessed from privileged mode.

The **FAULTSTAT** register indicates the cause of a memory management fault, bus fault, or usage fault. Each of these functions is assigned to a subregister as follows:

- **Usage Fault Status (UFAULTSTAT)**, bits 31:16
- **Bus Fault Status (BFAULTSTAT)**, bits 15:8
- **Memory Management Fault Status (MFAULTSTAT)**, bits 7:0

FAULTSTAT is byte accessible. **FAULTSTAT** or its subregisters can be accessed as follows:

- The complete **FAULTSTAT** register, with a word access to offset 0xD28
- The **MFAULTSTAT**, with a byte access to offset 0xD28
- The **MFAULTSTAT** and **BFAULTSTAT**, with a halfword access to offset 0xD28
- The **BFAULTSTAT**, with a byte access to offset 0xD29
- The **UFAULTSTAT**, with a halfword access to offset 0xD2A

Bits are cleared by writing a 1 to them.

In a fault handler, the true faulting address can be determined by:

1. Read and save the **Memory Management Fault Address (MMADDR)** or **Bus Fault Address (FAULTADDR)** value.
2. Read the **MMARV** bit in **MFAULTSTAT**, or the **BFARV** bit in **BFAULTSTAT** to determine if the **MMADDR** or **FAULTADDR** contents are valid.

Software must follow this sequence because another higher priority exception might change the **MMADDR** or **FAULTADDR** value. For example, if a higher priority handler preempts the current fault handler, the other fault might change the **MMADDR** or **FAULTADDR** value.

Configurable Fault Status (FAULTSTAT)

Base 0xE000.E000

Offset 0xD28

Type R/W1C, reset 0x0000.0000

	31	30	29	28	27	26	25	24	23	22	21	20	19	18	17	16
	reserved						DIV0	UNALIGN	reserved				NOCP	INVPC	INVSTAT	UNDEF
Type	RO	RO	RO	RO	RO	RO	R/W1C	R/W1C	RO	RO	RO	RO	R/W1C	R/W1C	R/W1C	R/W1C
Reset	0	0	0	0	0	0	0	0	0	0	0	0	0	0	0	0
	15	14	13	12	11	10	9	8	7	6	5	4	3	2	1	0
	BFARV	reserved	BLSPERR	BSTKE	BUSTKE	IMPRE	PRECISE	IBUS	MMARV	reserved	MLSPERR	MSTKE	MUSTKE	reserved	DERR	IERR
Type	R/W1C	RO	R/W1C	R/W1C	R/W1C	R/W1C	R/W1C	R/W1C	R/W1C	RO	R/W1C	R/W1C	R/W1C	RO	R/W1C	R/W1C
Reset	0	0	0	0	0	0	0	0	0	0	0	0	0	0	0	0

Bit/Field	Name	Type	Reset	Description
31:26	reserved	RO	0x00	Software should not rely on the value of a reserved bit. To provide compatibility with future products, the value of a reserved bit should be preserved across a read-modify-write operation.

Bit/Field	Name	Type	Reset	Description
25	DIV0	R/W1C	0	<p>Divide-by-Zero Usage Fault</p> <p>Value Description</p> <p>0 No divide-by-zero fault has occurred, or divide-by-zero trapping is not enabled.</p> <p>1 The processor has executed an SDIV or UDIV instruction with a divisor of 0.</p> <p>When this bit is set, the PC value stacked for the exception return points to the instruction that performed the divide by zero.</p> <p>Trapping on divide-by-zero is enabled by setting the DIV0 bit in the Configuration and Control (CFGCTRL) register (see page 169).</p> <p>This bit is cleared by writing a 1 to it.</p>
24	UNALIGN	R/W1C	0	<p>Unaligned Access Usage Fault</p> <p>Value Description</p> <p>0 No unaligned access fault has occurred, or unaligned access trapping is not enabled.</p> <p>1 The processor has made an unaligned memory access.</p> <p>Unaligned LDM, STM, LDRD, and STRD instructions always fault regardless of the configuration of this bit.</p> <p>Trapping on unaligned access is enabled by setting the UNALIGNED bit in the CFGCTRL register (see page 169).</p> <p>This bit is cleared by writing a 1 to it.</p>
23:20	reserved	RO	0x00	Software should not rely on the value of a reserved bit. To provide compatibility with future products, the value of a reserved bit should be preserved across a read-modify-write operation.
19	NOCP	R/W1C	0	<p>No Coprocessor Usage Fault</p> <p>Value Description</p> <p>0 A usage fault has not been caused by attempting to access a coprocessor.</p> <p>1 The processor has attempted to access a coprocessor.</p> <p>This bit is cleared by writing a 1 to it.</p>
18	INVPC	R/W1C	0	<p>Invalid PC Load Usage Fault</p> <p>Value Description</p> <p>0 A usage fault has not been caused by attempting to load an invalid PC value.</p> <p>1 The processor has attempted an illegal load of EXC_RETURN to the PC as a result of an invalid context or an invalid EXC_RETURN value.</p> <p>When this bit is set, the PC value stacked for the exception return points to the instruction that tried to perform the illegal load of the PC.</p> <p>This bit is cleared by writing a 1 to it.</p>

Bit/Field	Name	Type	Reset	Description
17	INVSTAT	R/W1C	0	<p>Invalid State Usage Fault</p> <p>Value Description</p> <p>0 A usage fault has not been caused by an invalid state.</p> <p>1 The processor has attempted to execute an instruction that makes illegal use of the EPSR register.</p> <p>When this bit is set, the PC value stacked for the exception return points to the instruction that attempted the illegal use of the Execution Program Status Register (EPSR) register.</p> <p>This bit is not set if an undefined instruction uses the EPSR register. This bit is cleared by writing a 1 to it.</p>
16	UNDEF	R/W1C	0	<p>Undefined Instruction Usage Fault</p> <p>Value Description</p> <p>0 A usage fault has not been caused by an undefined instruction.</p> <p>1 The processor has attempted to execute an undefined instruction.</p> <p>When this bit is set, the PC value stacked for the exception return points to the undefined instruction.</p> <p>An undefined instruction is an instruction that the processor cannot decode.</p> <p>This bit is cleared by writing a 1 to it.</p>
15	BFARV	R/W1C	0	<p>Bus Fault Address Register Valid</p> <p>Value Description</p> <p>0 The value in the Bus Fault Address (FAULTADDR) register is not a valid fault address.</p> <p>1 The FAULTADDR register is holding a valid fault address.</p> <p>This bit is set after a bus fault, where the address is known. Other faults can clear this bit, such as a memory management fault occurring later. If a bus fault occurs and is escalated to a hard fault because of priority, the hard fault handler must clear this bit. This action prevents problems if returning to a stacked active bus fault handler whose FAULTADDR register value has been overwritten.</p> <p>This bit is cleared by writing a 1 to it.</p>
14	reserved	RO	0	<p>Software should not rely on the value of a reserved bit. To provide compatibility with future products, the value of a reserved bit should be preserved across a read-modify-write operation.</p>
13	BLSPERR	R/W1C	0	<p>Bus Fault on Floating-Point Lazy State Preservation</p> <p>Value Description</p> <p>0 No bus fault has occurred during floating-point lazy state preservation.</p> <p>1 A bus fault has occurred during floating-point lazy state preservation.</p> <p>This bit is cleared by writing a 1 to it.</p>

Bit/Field	Name	Type	Reset	Description
12	BSTKE	R/W1C	0	<p>Stack Bus Fault</p> <p>Value Description</p> <p>0 No bus fault has occurred on stacking for exception entry.</p> <p>1 Stacking for an exception entry has caused one or more bus faults.</p> <p>When this bit is set, the SP is still adjusted but the values in the context area on the stack might be incorrect. A fault address is not written to the FAULTADDR register.</p> <p>This bit is cleared by writing a 1 to it.</p>
11	BUSTKE	R/W1C	0	<p>Unstack Bus Fault</p> <p>Value Description</p> <p>0 No bus fault has occurred on unstacking for a return from exception.</p> <p>1 Unstacking for a return from exception has caused one or more bus faults.</p> <p>This fault is chained to the handler. Thus, when this bit is set, the original return stack is still present. The SP is not adjusted from the failing return, a new save is not performed, and a fault address is not written to the FAULTADDR register.</p> <p>This bit is cleared by writing a 1 to it.</p>
10	IMPRE	R/W1C	0	<p>Imprecise Data Bus Error</p> <p>Value Description</p> <p>0 An imprecise data bus error has not occurred.</p> <p>1 A data bus error has occurred, but the return address in the stack frame is not related to the instruction that caused the error.</p> <p>When this bit is set, a fault address is not written to the FAULTADDR register.</p> <p>This fault is asynchronous. Therefore, if the fault is detected when the priority of the current process is higher than the bus fault priority, the bus fault becomes pending and becomes active only when the processor returns from all higher-priority processes. If a precise fault occurs before the processor enters the handler for the imprecise bus fault, the handler detects that both the IMPRE bit is set and one of the precise fault status bits is set.</p> <p>This bit is cleared by writing a 1 to it.</p>
9	PRECISE	R/W1C	0	<p>Precise Data Bus Error</p> <p>Value Description</p> <p>0 A precise data bus error has not occurred.</p> <p>1 A data bus error has occurred, and the PC value stacked for the exception return points to the instruction that caused the fault.</p> <p>When this bit is set, the fault address is written to the FAULTADDR register.</p> <p>This bit is cleared by writing a 1 to it.</p>

Bit/Field	Name	Type	Reset	Description
8	IBUS	R/W1C	0	<p>Instruction Bus Error</p> <p>Value Description</p> <p>0 An instruction bus error has not occurred.</p> <p>1 An instruction bus error has occurred.</p> <p>The processor detects the instruction bus error on prefetching an instruction, but sets this bit only if it attempts to issue the faulting instruction.</p> <p>When this bit is set, a fault address is not written to the FAULTADDR register.</p> <p>This bit is cleared by writing a 1 to it.</p>
7	MMARV	R/W1C	0	<p>Memory Management Fault Address Register Valid</p> <p>Value Description</p> <p>0 The value in the Memory Management Fault Address (MMADDR) register is not a valid fault address.</p> <p>1 The MMADDR register is holding a valid fault address.</p> <p>If a memory management fault occurs and is escalated to a hard fault because of priority, the hard fault handler must clear this bit. This action prevents problems if returning to a stacked active memory management fault handler whose MMADDR register value has been overwritten.</p> <p>This bit is cleared by writing a 1 to it.</p>
6	reserved	RO	0	<p>Software should not rely on the value of a reserved bit. To provide compatibility with future products, the value of a reserved bit should be preserved across a read-modify-write operation.</p>
5	MLSPERR	R/W1C	0	<p>Memory Management Fault on Floating-Point Lazy State Preservation</p> <p>Value Description</p> <p>0 No memory management fault has occurred during floating-point lazy state preservation.</p> <p>1 No memory management fault has occurred during floating-point lazy state preservation.</p> <p>This bit is cleared by writing a 1 to it.</p>
4	MSTKE	R/W1C	0	<p>Stack Access Violation</p> <p>Value Description</p> <p>0 No memory management fault has occurred on stacking for exception entry.</p> <p>1 Stacking for an exception entry has caused one or more access violations.</p> <p>When this bit is set, the SP is still adjusted but the values in the context area on the stack might be incorrect. A fault address is not written to the MMADDR register.</p> <p>This bit is cleared by writing a 1 to it.</p>

Bit/Field	Name	Type	Reset	Description
3	MUSTKE	R/W1C	0	<p>Unstack Access Violation</p> <p>Value Description</p> <p>0 No memory management fault has occurred on unstacking for a return from exception.</p> <p>1 Unstacking for a return from exception has caused one or more access violations.</p> <p>This fault is chained to the handler. Thus, when this bit is set, the original return stack is still present. The SP is not adjusted from the failing return, a new save is not performed, and a fault address is not written to the MMADDR register.</p> <p>This bit is cleared by writing a 1 to it.</p>
2	reserved	RO	0	<p>Software should not rely on the value of a reserved bit. To provide compatibility with future products, the value of a reserved bit should be preserved across a read-modify-write operation.</p>
1	DERR	R/W1C	0	<p>Data Access Violation</p> <p>Value Description</p> <p>0 A data access violation has not occurred.</p> <p>1 The processor attempted a load or store at a location that does not permit the operation.</p> <p>When this bit is set, the PC value stacked for the exception return points to the faulting instruction and the address of the attempted access is written to the MMADDR register.</p> <p>This bit is cleared by writing a 1 to it.</p>
0	IERR	R/W1C	0	<p>Instruction Access Violation</p> <p>Value Description</p> <p>0 An instruction access violation has not occurred.</p> <p>1 The processor attempted an instruction fetch from a location that does not permit execution.</p> <p>This fault occurs on any access to an XN region, even when the MPU is disabled or not present.</p> <p>When this bit is set, the PC value stacked for the exception return points to the faulting instruction and the address of the attempted access is not written to the MMADDR register.</p> <p>This bit is cleared by writing a 1 to it.</p>

Register 77: Hard Fault Status (HFAULTSTAT), offset 0xD2C

Note: This register can only be accessed from privileged mode.

The **HFAULTSTAT** register gives information about events that activate the hard fault handler.

Bits are cleared by writing a 1 to them.

Hard Fault Status (HFAULTSTAT)

Base 0xE000.E000

Offset 0xD2C

Type R/W1C, reset 0x0000.0000

	31	30	29	28	27	26	25	24	23	22	21	20	19	18	17	16	
	DBG	FORCED	reserved														
Type	R/W1C	R/W1C	RO	RO	RO	RO	RO	RO	RO	RO	RO	RO	RO	RO	RO	RO	
Reset	0	0	0	0	0	0	0	0	0	0	0	0	0	0	0	0	
	15	14	13	12	11	10	9	8	7	6	5	4	3	2	1	0	
	reserved														VECT	reserved	
Type	RO	RO	RO	RO	RO	RO	RO	RO	RO	RO	RO	RO	RO	RO	RO	R/W1C	RO
Reset	0	0	0	0	0	0	0	0	0	0	0	0	0	0	0	0	0

Bit/Field	Name	Type	Reset	Description
31	DBG	R/W1C	0	Debug Event This bit is reserved for Debug use. This bit must be written as a 0, otherwise behavior is unpredictable.
30	FORCED	R/W1C	0	Forced Hard Fault Value Description 0 No forced hard fault has occurred. 1 A forced hard fault has been generated by escalation of a fault with configurable priority that cannot be handled, either because of priority or because it is disabled. When this bit is set, the hard fault handler must read the other fault status registers to find the cause of the fault. This bit is cleared by writing a 1 to it.
29:2	reserved	RO	0x00	Software should not rely on the value of a reserved bit. To provide compatibility with future products, the value of a reserved bit should be preserved across a read-modify-write operation.
1	VECT	R/W1C	0	Vector Table Read Fault Value Description 0 No bus fault has occurred on a vector table read. 1 A bus fault occurred on a vector table read. This error is always handled by the hard fault handler. When this bit is set, the PC value stacked for the exception return points to the instruction that was preempted by the exception. This bit is cleared by writing a 1 to it.
0	reserved	RO	0	Software should not rely on the value of a reserved bit. To provide compatibility with future products, the value of a reserved bit should be preserved across a read-modify-write operation.

Register 78: Memory Management Fault Address (MMADDR), offset 0xD34

Note: This register can only be accessed from privileged mode.

The **MMADDR** register contains the address of the location that generated a memory management fault. When an unaligned access faults, the address in the **MMADDR** register is the actual address that faulted. Because a single read or write instruction can be split into multiple aligned accesses, the fault address can be any address in the range of the requested access size. Bits in the **Memory Management Fault Status (MFAULTSTAT)** register indicate the cause of the fault and whether the value in the **MMADDR** register is valid (see page 178).

Memory Management Fault Address (MMADDR)

Base 0xE000.E000

Offset 0xD34

Type R/W, reset -

	31	30	29	28	27	26	25	24	23	22	21	20	19	18	17	16
	ADDR															
Type	R/W	R/W	R/W	R/W	R/W	R/W	R/W	R/W	R/W	R/W	R/W	R/W	R/W	R/W	R/W	R/W
Reset	-	-	-	-	-	-	-	-	-	-	-	-	-	-	-	-
	15	14	13	12	11	10	9	8	7	6	5	4	3	2	1	0
	ADDR															
Type	R/W	R/W	R/W	R/W	R/W	R/W	R/W	R/W	R/W	R/W	R/W	R/W	R/W	R/W	R/W	R/W
Reset	-	-	-	-	-	-	-	-	-	-	-	-	-	-	-	-

Bit/Field	Name	Type	Reset	Description
31:0	ADDR	R/W	-	Fault Address When the MMARV bit of MFAULTSTAT is set, this field holds the address of the location that generated the memory management fault.

Register 79: Bus Fault Address (FAULTADDR), offset 0xD38

Note: This register can only be accessed from privileged mode.

The **FAULTADDR** register contains the address of the location that generated a bus fault. When an unaligned access faults, the address in the **FAULTADDR** register is the one requested by the instruction, even if it is not the address of the fault. Bits in the **Bus Fault Status (BFAULTSTAT)** register indicate the cause of the fault and whether the value in the **FAULTADDR** register is valid (see page 178).

Bus Fault Address (FAULTADDR)

Base 0xE000.E000

Offset 0xD38

Type R/W, reset -

	31	30	29	28	27	26	25	24	23	22	21	20	19	18	17	16
	ADDR															
Type	R/W	R/W	R/W	R/W	R/W	R/W	R/W	R/W	R/W	R/W	R/W	R/W	R/W	R/W	R/W	R/W
Reset	-	-	-	-	-	-	-	-	-	-	-	-	-	-	-	-
	15	14	13	12	11	10	9	8	7	6	5	4	3	2	1	0
	ADDR															
Type	R/W	R/W	R/W	R/W	R/W	R/W	R/W	R/W	R/W	R/W	R/W	R/W	R/W	R/W	R/W	R/W
Reset	-	-	-	-	-	-	-	-	-	-	-	-	-	-	-	-

Bit/Field	Name	Type	Reset	Description
31:0	ADDR	R/W	-	Fault Address When the FAULTADDRV bit of BFAULTSTAT is set, this field holds the address of the location that generated the bus fault.

3.6 Memory Protection Unit (MPU) Register Descriptions

This section lists and describes the Memory Protection Unit (MPU) registers, in numerical order by address offset.

The MPU registers can only be accessed from privileged mode.

Register 80: MPU Type (MPUTYPE), offset 0xD90

Note: This register can only be accessed from privileged mode.

The **MPUTYPE** register indicates whether the MPU is present, and if so, how many regions it supports.

MPU Type (MPUTYPE)

Base 0xE000.E000

Offset 0xD90

Type RO, reset 0x0000.0800

	31	30	29	28	27	26	25	24	23	22	21	20	19	18	17	16
	reserved								IREGION							
Type	RO	RO	RO	RO	RO	RO	RO	RO	RO	RO	RO	RO	RO	RO	RO	RO
Reset	0	0	0	0	0	0	0	0	0	0	0	0	0	0	0	0
	15	14	13	12	11	10	9	8	7	6	5	4	3	2	1	0
	DREGION								reserved							SEPARATE
Type	RO	RO	RO	RO	RO	RO	RO	RO	RO	RO	RO	RO	RO	RO	RO	RO
Reset	0	0	0	0	1	0	0	0	0	0	0	0	0	0	0	0

Bit/Field	Name	Type	Reset	Description
31:24	reserved	RO	0x00	Software should not rely on the value of a reserved bit. To provide compatibility with future products, the value of a reserved bit should be preserved across a read-modify-write operation.
23:16	IREGION	RO	0x00	Number of I Regions This field indicates the number of supported MPU instruction regions. This field always contains 0x00. The MPU memory map is unified and is described by the DREGION field.
15:8	DREGION	RO	0x08	Number of D Regions Value Description 0x08 Indicates there are eight supported MPU data regions.
7:1	reserved	RO	0x00	Software should not rely on the value of a reserved bit. To provide compatibility with future products, the value of a reserved bit should be preserved across a read-modify-write operation.
0	SEPARATE	RO	0	Separate or Unified MPU Value Description 0 Indicates the MPU is unified.

Register 81: MPU Control (MPUCTRL), offset 0xD94

Note: This register can only be accessed from privileged mode.

The **MPUCTRL** register enables the MPU, enables the default memory map background region, and enables use of the MPU when in the hard fault, Non-maskable Interrupt (NMI), and **Fault Mask Register (FAULTMASK)** escalated handlers.

When the **ENABLE** and **PRIVDEFEN** bits are both set:

- For privileged accesses, the default memory map is as described in “Memory Model” on page 93. Any access by privileged software that does not address an enabled memory region behaves as defined by the default memory map.
- Any access by unprivileged software that does not address an enabled memory region causes a memory management fault.

Execute Never (XN) and Strongly Ordered rules always apply to the System Control Space regardless of the value of the **ENABLE** bit.

When the **ENABLE** bit is set, at least one region of the memory map must be enabled for the system to function unless the **PRIVDEFEN** bit is set. If the **PRIVDEFEN** bit is set and no regions are enabled, then only privileged software can operate.

When the **ENABLE** bit is clear, the system uses the default memory map, which has the same memory attributes as if the MPU is not implemented (see Table 2-5 on page 96 for more information). The default memory map applies to accesses from both privileged and unprivileged software.

When the MPU is enabled, accesses to the System Control Space and vector table are always permitted. Other areas are accessible based on regions and whether **PRIVDEFEN** is set.

Unless **HFNMENA** is set, the MPU is not enabled when the processor is executing the handler for an exception with priority –1 or –2. These priorities are only possible when handling a hard fault or NMI exception or when **FAULTMASK** is enabled. Setting the **HFNMENA** bit enables the MPU when operating with these two priorities.

MPU Control (MPUCTRL)

Base 0xE000.E000
Offset 0xD94
Type R/W, reset 0x0000.0000

	31	30	29	28	27	26	25	24	23	22	21	20	19	18	17	16	
	reserved																
Type	RO	RO	RO	RO	RO	RO	RO	RO	RO	RO	RO	RO	RO	RO	RO	RO	
Reset	0	0	0	0	0	0	0	0	0	0	0	0	0	0	0	0	
	15	14	13	12	11	10	9	8	7	6	5	4	3	2	1	0	
	reserved													PRIVDEFEN	HFNMENA	ENABLE	
Type	RO	RO	RO	RO	RO	RO	RO	RO	RO	RO	RO	RO	RO	RO	R/W	R/W	R/W
Reset	0	0	0	0	0	0	0	0	0	0	0	0	0	0	0	0	0

Bit/Field	Name	Type	Reset	Description
31:3	reserved	RO	0x0000.000	Software should not rely on the value of a reserved bit. To provide compatibility with future products, the value of a reserved bit should be preserved across a read-modify-write operation.

Bit/Field	Name	Type	Reset	Description
2	PRIVDEFEN	R/W	0	<p>MPU Default Region</p> <p>This bit enables privileged software access to the default memory map.</p> <p>Value Description</p> <p>0 If the MPU is enabled, this bit disables use of the default memory map. Any memory access to a location not covered by any enabled region causes a fault.</p> <p>1 If the MPU is enabled, this bit enables use of the default memory map as a background region for privileged software accesses.</p> <p>When this bit is set, the background region acts as if it is region number -1. Any region that is defined and enabled has priority over this default map.</p> <p>If the MPU is disabled, the processor ignores this bit.</p>
1	HFNMIENA	R/W	0	<p>MPU Enabled During Faults</p> <p>This bit controls the operation of the MPU during hard fault, NMI, and FAULTMASK handlers.</p> <p>Value Description</p> <p>0 The MPU is disabled during hard fault, NMI, and FAULTMASK handlers, regardless of the value of the <i>ENABLE</i> bit.</p> <p>1 The MPU is enabled during hard fault, NMI, and FAULTMASK handlers.</p> <p>When the MPU is disabled and this bit is set, the resulting behavior is unpredictable.</p>
0	ENABLE	R/W	0	<p>MPU Enable</p> <p>Value Description</p> <p>0 The MPU is disabled.</p> <p>1 The MPU is enabled.</p> <p>When the MPU is disabled and the <i>HFNMIENA</i> bit is set, the resulting behavior is unpredictable.</p>

Register 82: MPU Region Number (MPUNUMBER), offset 0xD98

Note: This register can only be accessed from privileged mode.

The **MPUNUMBER** register selects which memory region is referenced by the **MPU Region Base Address (MPUBASE)** and **MPU Region Attribute and Size (MPUATTR)** registers. Normally, the required region number should be written to this register before accessing the **MPUBASE** or the **MPUATTR** register. However, the region number can be changed by writing to the **MPUBASE** register with the **VALID** bit set (see page 191). This write updates the value of the **REGION** field.

MPU Region Number (MPUNUMBER)

Base 0xE000.E000

Offset 0xD98

Type R/W, reset 0x0000.0000

	31	30	29	28	27	26	25	24	23	22	21	20	19	18	17	16	
	reserved																
Type	RO	RO	RO	RO	RO	RO	RO	RO	RO	RO	RO	RO	RO	RO	RO	RO	
Reset	0	0	0	0	0	0	0	0	0	0	0	0	0	0	0	0	
	15	14	13	12	11	10	9	8	7	6	5	4	3	2	1	0	
	reserved													NUMBER			
Type	RO	RO	RO	RO	RO	RO	RO	RO	RO	RO	RO	RO	RO	RO	R/W	R/W	R/W
Reset	0	0	0	0	0	0	0	0	0	0	0	0	0	0	0	0	0

Bit/Field	Name	Type	Reset	Description
31:3	reserved	RO	0x0000.000	Software should not rely on the value of a reserved bit. To provide compatibility with future products, the value of a reserved bit should be preserved across a read-modify-write operation.
2:0	NUMBER	R/W	0x0	MPU Region to Access This field indicates the MPU region referenced by the MPUBASE and MPUATTR registers. The MPU supports eight memory regions.

Register 83: MPU Region Base Address (MPUBASE), offset 0xD9C**Register 84: MPU Region Base Address Alias 1 (MPUBASE1), offset 0xDA4****Register 85: MPU Region Base Address Alias 2 (MPUBASE2), offset 0xDAC****Register 86: MPU Region Base Address Alias 3 (MPUBASE3), offset 0xDB4**

Note: This register can only be accessed from privileged mode.

The **MPUBASE** register defines the base address of the MPU region selected by the **MPU Region Number (MPUNUMBER)** register and can update the value of the **MPUNUMBER** register. To change the current region number and update the **MPUNUMBER** register, write the **MPUBASE** register with the **VALID** bit set.

The **ADDR** field is bits 31:*N* of the **MPUBASE** register. Bits (*N*-1):5 are reserved. The region size, as specified by the **SIZE** field in the **MPU Region Attribute and Size (MPUATTR)** register, defines the value of *N* where:

$$N = \text{Log}_2(\text{Region size in bytes})$$

If the region size is configured to 4 GB in the **MPUATTR** register, there is no valid **ADDR** field. In this case, the region occupies the complete memory map, and the base address is 0x0000.0000.

The base address is aligned to the size of the region. For example, a 64-KB region must be aligned on a multiple of 64 KB, for example, at 0x0001.0000 or 0x0002.0000.

MPU Region Base Address (MPUBASE)

Base 0xE000.E000

Offset 0xD9C

Type R/W, reset 0x0000.0000

	31	30	29	28	27	26	25	24	23	22	21	20	19	18	17	16	
	ADDR																
Type	R/W	R/W	R/W	R/W	R/W	R/W	R/W	R/W	R/W	R/W	R/W	R/W	R/W	R/W	R/W	R/W	
Reset	0	0	0	0	0	0	0	0	0	0	0	0	0	0	0	0	
	15	14	13	12	11	10	9	8	7	6	5	4	3	2	1	0	
	ADDR												VALID	reserved	REGION		
Type	R/W	R/W	R/W	R/W	R/W	R/W	R/W	R/W	R/W	R/W	R/W	R/W	WO	RO	R/W	R/W	R/W
Reset	0	0	0	0	0	0	0	0	0	0	0	0	0	0	0	0	0

Bit/Field	Name	Type	Reset	Description
31:5	ADDR	R/W	0x0000.000	<p>Base Address Mask</p> <p>Bits 31:<i>N</i> in this field contain the region base address. The value of <i>N</i> depends on the region size, as shown above. The remaining bits (<i>N</i>-1):5 are reserved.</p> <p>Software should not rely on the value of a reserved bit. To provide compatibility with future products, the value of a reserved bit should be preserved across a read-modify-write operation.</p>

Bit/Field	Name	Type	Reset	Description
4	VALID	WO	0	<p>Region Number Valid</p> <p>Value Description</p> <p>0 The MPUNUMBER register is not changed and the processor updates the base address for the region specified in the MPUNUMBER register and ignores the value of the REGION field.</p> <p>1 The MPUNUMBER register is updated with the value of the REGION field and the base address is updated for the region specified in the REGION field.</p> <p>This bit is always read as 0.</p>
3	reserved	RO	0	Software should not rely on the value of a reserved bit. To provide compatibility with future products, the value of a reserved bit should be preserved across a read-modify-write operation.
2:0	REGION	R/W	0x0	<p>Region Number</p> <p>On a write, contains the value to be written to the MPUNUMBER register. On a read, returns the current region number in the MPUNUMBER register.</p>

Register 87: MPU Region Attribute and Size (MPUATTR), offset 0xDA0**Register 88: MPU Region Attribute and Size Alias 1 (MPUATTR1), offset 0xDA8****Register 89: MPU Region Attribute and Size Alias 2 (MPUATTR2), offset 0xDB0****Register 90: MPU Region Attribute and Size Alias 3 (MPUATTR3), offset 0xDB8**

Note: This register can only be accessed from privileged mode.

The **MPUATTR** register defines the region size and memory attributes of the MPU region specified by the **MPU Region Number (MPUNUMBER)** register and enables that region and any subregions.

The **MPUATTR** register is accessible using word or halfword accesses with the most-significant halfword holding the region attributes and the least-significant halfword holds the region size and the region and subregion enable bits.

The MPU access permission attribute bits, **XN**, **AP**, **TEX**, **S**, **C**, and **B**, control access to the corresponding memory region. If an access is made to an area of memory without the required permissions, then the MPU generates a permission fault.

The **SIZE** field defines the size of the MPU memory region specified by the **MPUNUMBER** register as follows:

$$(\text{Region size in bytes}) = 2^{(\text{SIZE}+1)}$$

The smallest permitted region size is 32 bytes, corresponding to a **SIZE** value of 4. Table 3-10 on page 193 gives example **SIZE** values with the corresponding region size and value of **N** in the **MPU Region Base Address (MPUBASE)** register.

Table 3-10. Example SIZE Field Values

SIZE Encoding	Region Size	Value of N ^a	Note
00100b (0x4)	32 B	5	Minimum permitted size
01001b (0x9)	1 KB	10	-
10011b (0x13)	1 MB	20	-
11101b (0x1D)	1 GB	30	-
11111b (0x1F)	4 GB	No valid ADDR field in MPUBASE ; the region occupies the complete memory map.	Maximum possible size

a. Refers to the N parameter in the **MPUBASE** register (see page 191).

MPU Region Attribute and Size (MPUATTR)

Base 0xE000.E000

Offset 0xDA0

Type R/W, reset 0x0000.0000

	31	30	29	28	27	26	25	24	23	22	21	20	19	18	17	16
	reserved			XN	reserved	AP		reserved			TEX		S	C	B	
Type	RO	RO	RO	R/W	RO	R/W	R/W	R/W	RO	RO	R/W	R/W	R/W	R/W	R/W	R/W
Reset	0	0	0	0	0	0	0	0	0	0	0	0	0	0	0	0
	15	14	13	12	11	10	9	8	7	6	5	4	3	2	1	0
	SRD								reserved			SIZE				ENABLE
Type	R/W	R/W	R/W	R/W	R/W	R/W	R/W	R/W	RO	RO	R/W	R/W	R/W	R/W	R/W	R/W
Reset	0	0	0	0	0	0	0	0	0	0	0	0	0	0	0	0

Bit/Field	Name	Type	Reset	Description
31:29	reserved	RO	0x00	Software should not rely on the value of a reserved bit. To provide compatibility with future products, the value of a reserved bit should be preserved across a read-modify-write operation.
28	XN	R/W	0	Instruction Access Disable Value Description 0 Instruction fetches are enabled. 1 Instruction fetches are disabled.
27	reserved	RO	0	Software should not rely on the value of a reserved bit. To provide compatibility with future products, the value of a reserved bit should be preserved across a read-modify-write operation.
26:24	AP	R/W	0	Access Privilege For information on using this bit field, see Table 3-5 on page 130.
23:22	reserved	RO	0x0	Software should not rely on the value of a reserved bit. To provide compatibility with future products, the value of a reserved bit should be preserved across a read-modify-write operation.
21:19	TEX	R/W	0x0	Type Extension Mask For information on using this bit field, see Table 3-3 on page 129.
18	S	R/W	0	Shareable For information on using this bit, see Table 3-3 on page 129.
17	C	R/W	0	Cacheable For information on using this bit, see Table 3-3 on page 129.
16	B	R/W	0	Bufferable For information on using this bit, see Table 3-3 on page 129.
15:8	SRD	R/W	0x00	Subregion Disable Bits Value Description 0 The corresponding subregion is enabled. 1 The corresponding subregion is disabled. Region sizes of 128 bytes and less do not support subregions. When writing the attributes for such a region, configure the SRD field as 0x00. See the section called "Subregions" on page 129 for more information.
7:6	reserved	RO	0x0	Software should not rely on the value of a reserved bit. To provide compatibility with future products, the value of a reserved bit should be preserved across a read-modify-write operation.
5:1	SIZE	R/W	0x0	Region Size Mask The SIZE field defines the size of the MPU memory region specified by the MPUNUMBER register. Refer to Table 3-10 on page 193 for more information.

Bit/Field	Name	Type	Reset	Description
0	ENABLE	R/W	0	Region Enable
				Value Description
				0 The region is disabled.
				1 The region is enabled.

3.7 Floating-Point Unit (FPU) Register Descriptions

This section lists and describes the Floating-Point Unit (FPU) registers, in numerical order by address offset.

Register 91: Coprocessor Access Control (CPAC), offset 0xD88

The **CPAC** register specifies the access privileges for coprocessors.

Coprocessor Access Control (CPAC)

Base 0xE000.E000

Offset 0xD88

Type R/W, reset 0x0000.0000

	31	30	29	28	27	26	25	24	23	22	21	20	19	18	17	16
	reserved								CP11		CP10		reserved			
Type	RO	RO	RO	RO	RO	RO	RO	RO	R/W	R/W	R/W	R/W	RO	RO	RO	RO
Reset	0	0	0	0	0	0	0	0	0	0	0	0	0	0	0	0
	15	14	13	12	11	10	9	8	7	6	5	4	3	2	1	0
	reserved															
Type	RO	RO	RO	RO	RO	RO	RO	RO	RO	RO	RO	RO	RO	RO	RO	RO
Reset	0	0	0	0	0	0	0	0	0	0	0	0	0	0	0	0

Bit/Field	Name	Type	Reset	Description
31:24	reserved	RO	0x00	Software should not rely on the value of a reserved bit. To provide compatibility with future products, the value of a reserved bit should be preserved across a read-modify-write operation.
23:22	CP11	R/W	0x00	CP11 Coprocessor Access Privilege Value Description 0x0 Access Denied Any attempted access generates a NOCP Usage Fault. 0x1 Privileged Access Only An unprivileged access generates a NOCP fault. 0x2 Reserved The result of any access is unpredictable. 0x3 Full Access
21:20	CP10	R/W	0x00	CP10 Coprocessor Access Privilege Value Description 0x0 Access Denied Any attempted access generates a NOCP Usage Fault. 0x1 Privileged Access Only An unprivileged access generates a NOCP fault. 0x2 Reserved The result of any access is unpredictable. 0x3 Full Access
19:0	reserved	RO	0x00	Software should not rely on the value of a reserved bit. To provide compatibility with future products, the value of a reserved bit should be preserved across a read-modify-write operation.

Register 92: Floating-Point Context Control (FPCC), offset 0xF34

The **FPCC** register sets or returns FPU control data.

Floating-Point Context Control (FPCC)

Base 0xE000.E000

Offset 0xF34

Type R/W, reset 0xC000.0000

	31	30	29	28	27	26	25	24	23	22	21	20	19	18	17	16
	ASPEN	LSPEN	reserved													
Type	R/W	R/W	RO	RO	RO	RO	RO	RO	RO	RO	RO	RO	RO	RO	RO	RO
Reset	1	1	0	0	0	0	0	0	0	0	0	0	0	0	0	0
	15	14	13	12	11	10	9	8	7	6	5	4	3	2	1	0
	reserved							MONRDY	reserved	BFRDY	MMRDY	HFRDY	THREAD	reserved	USER	LSPACT
Type	RO	RO	RO	RO	RO	RO	RO	R/W	RO	R/W	R/W	R/W	R/W	RO	R/W	R/W
Reset	0	0	0	0	0	0	0	0	0	0	0	0	0	0	0	0

Bit/Field	Name	Type	Reset	Description
31	ASPEN	R/W	1	<p>Automatic State Preservation Enable</p> <p>When set, enables the use of the <code>FRACTV</code> bit in the CONTROL register on execution of a floating-point instruction. This results in automatic hardware state preservation and restoration, for floating-point context, on exception entry and exit.</p> <hr/> <p>Important: Two bits control when <code>FPCA</code> can be enabled: the <code>ASPEN</code> bit in the Floating-Point Context Control (FPCC) register and the <code>DISFPCA</code> bit in the Auxiliary Control (ACTLR) register.</p> <hr/>
30	LSPEN	R/W	1	<p>Lazy State Preservation Enable</p> <p>When set, enables automatic lazy state preservation for floating-point context.</p>
29:9	reserved	RO	0x00	<p>Software should not rely on the value of a reserved bit. To provide compatibility with future products, the value of a reserved bit should be preserved across a read-modify-write operation.</p>
8	MONRDY	R/W	0	<p>Monitor Ready</p> <p>When set, DebugMonitor is enabled and priority permits setting <code>MON_PEND</code> when the floating-point stack frame was allocated.</p>
7	reserved	RO	0	<p>Software should not rely on the value of a reserved bit. To provide compatibility with future products, the value of a reserved bit should be preserved across a read-modify-write operation.</p>
6	BFRDY	R/W	0	<p>Bus Fault Ready</p> <p>When set, BusFault is enabled and priority permitted setting the BusFault handler to the pending state when the floating-point stack frame was allocated.</p>
5	MMRDY	R/W	0	<p>Memory Management Fault Ready</p> <p>When set, MemManage is enabled and priority permitted setting the MemManage handler to the pending state when the floating-point stack frame was allocated.</p>

Bit/Field	Name	Type	Reset	Description
4	HFRDY	R/W	0	Hard Fault Ready When set, priority permitted setting the HardFault handler to the pending state when the floating-point stack frame was allocated.
3	THREAD	R/W	0	Thread Mode When set, mode was Thread Mode when the floating-point stack frame was allocated.
2	reserved	RO	0	Software should not rely on the value of a reserved bit. To provide compatibility with future products, the value of a reserved bit should be preserved across a read-modify-write operation.
1	USER	R/W	0	User Privilege Level When set, privilege level was user when the floating-point stack frame was allocated.
0	LSPACT	R/W	0	Lazy State Preservation Active When set, Lazy State preservation is active. Floating-point stack frame has been allocated but saving state to it has been deferred.

Register 93: Floating-Point Context Address (FPCA), offset 0xF38

The **FPCA** register holds the location of the unpopulated floating-point register space allocated on an exception stack frame.

Floating-Point Context Address (FPCA)

Base 0xE000.E000

Offset 0xF38

Type R/W, reset -

	31	30	29	28	27	26	25	24	23	22	21	20	19	18	17	16
	ADDRESS															
Type	R/W	R/W	R/W	R/W	R/W	R/W	R/W	R/W	R/W	R/W	R/W	R/W	R/W	R/W	R/W	R/W
Reset	-	-	-	-	-	-	-	-	-	-	-	-	-	-	-	-
	15	14	13	12	11	10	9	8	7	6	5	4	3	2	1	0
	ADDRESS													reserved		
Type	R/W	R/W	R/W	R/W	R/W	R/W	R/W	R/W	R/W	R/W	R/W	R/W	R/W	RO	RO	RO
Reset	-	-	-	-	-	-	-	-	-	-	-	-	-	0	0	0

Bit/Field	Name	Type	Reset	Description
31:3	ADDRESS	R/W	-	Address The location of the unpopulated floating-point register space allocated on an exception stack frame.
2:0	reserved	RO	0x00	Software should not rely on the value of a reserved bit. To provide compatibility with future products, the value of a reserved bit should be preserved across a read-modify-write operation.

Register 94: Floating-Point Default Status Control (FPDSC), offset 0xF3C

The **FPDSC** register holds the default values for the **Floating-Point Status Control (FPSC)** register.

Floating-Point Default Status Control (FPDSC)

Base 0xE000.E000

Offset 0xF3C

Type R/W, reset 0x0000.0000

	31	30	29	28	27	26	25	24	23	22	21	20	19	18	17	16
	reserved					AHP	DN	FZ	RMODE		reserved					
Type	RO	RO	RO	RO	RO	R/W	R/W	R/W	R/W	R/W	RO	RO	RO	RO	RO	RO
Reset	0	0	0	0	0	-	-	-	-	-	0	0	0	0	0	0
	15	14	13	12	11	10	9	8	7	6	5	4	3	2	1	0
	reserved															
Type	RO	RO	RO	RO	RO	RO	RO	RO	RO	RO	RO	RO	RO	RO	RO	RO
Reset	0	0	0	0	0	0	0	0	0	0	0	0	0	0	0	0

Bit/Field	Name	Type	Reset	Description										
31:27	reserved	RO	0x00	Software should not rely on the value of a reserved bit. To provide compatibility with future products, the value of a reserved bit should be preserved across a read-modify-write operation.										
26	AHP	R/W	-	AHP Bit Default This bit holds the default value for the <code>AHP</code> bit in the FPSC register.										
25	DN	R/W	-	DN Bit Default This bit holds the default value for the <code>DN</code> bit in the FPSC register.										
24	FZ	R/W	-	FZ Bit Default This bit holds the default value for the <code>FZ</code> bit in the FPSC register.										
23:22	RMODE	R/W	-	RMODE Bit Default This bit holds the default value for the <code>RMODE</code> bit field in the FPSC register. <table border="0"> <thead> <tr> <th>Value</th> <th>Description</th> </tr> </thead> <tbody> <tr> <td>0x0</td> <td>Round to Nearest (RN) mode</td> </tr> <tr> <td>0x1</td> <td>Round towards Plus Infinity (RP) mode</td> </tr> <tr> <td>0x2</td> <td>Round towards Minus Infinity (RM) mode</td> </tr> <tr> <td>0x3</td> <td>Round towards Zero (RZ) mode</td> </tr> </tbody> </table>	Value	Description	0x0	Round to Nearest (RN) mode	0x1	Round towards Plus Infinity (RP) mode	0x2	Round towards Minus Infinity (RM) mode	0x3	Round towards Zero (RZ) mode
Value	Description													
0x0	Round to Nearest (RN) mode													
0x1	Round towards Plus Infinity (RP) mode													
0x2	Round towards Minus Infinity (RM) mode													
0x3	Round towards Zero (RZ) mode													
21:0	reserved	RO	0x00	Software should not rely on the value of a reserved bit. To provide compatibility with future products, the value of a reserved bit should be preserved across a read-modify-write operation.										

4 JTAG Interface

The Joint Test Action Group (JTAG) port is an IEEE standard that defines a Test Access Port and Boundary Scan Architecture for digital integrated circuits and provides a standardized serial interface for controlling the associated test logic. The TAP, Instruction Register (IR), and Data Registers (DR) can be used to test the interconnections of assembled printed circuit boards and obtain manufacturing information on the components. The JTAG Port also provides a means of accessing and controlling design-for-test features such as I/O pin observation and control, scan testing, and debugging.

The JTAG port is comprised of four pins: TCK, TMS, TDI, and TDO. Data is transmitted serially into the controller on TDI and out of the controller on TDO. The interpretation of this data is dependent on the current state of the TAP controller. For detailed information on the operation of the JTAG port and TAP controller, please refer to the *IEEE Standard 1149.1-Test Access Port and Boundary-Scan Architecture*.

The Stellaris® JTAG controller works with the ARM JTAG controller built into the Cortex-M4F core by multiplexing the TDO outputs from both JTAG controllers. ARM JTAG instructions select the ARM TDO output while Stellaris JTAG instructions select the Stellaris TDO output. The multiplexer is controlled by the Stellaris JTAG controller, which has comprehensive programming for the ARM, Stellaris, and unimplemented JTAG instructions.

The Stellaris JTAG module has the following features:

- IEEE 1149.1-1990 compatible Test Access Port (TAP) controller
- Four-bit Instruction Register (IR) chain for storing JTAG instructions
- IEEE standard instructions: BYPASS, IDCODE, SAMPLE/PRELOAD, EXTEST and INTEST
- ARM additional instructions: APACC, DPACC and ABORT
- Integrated ARM Serial Wire Debug (SWD)
 - Serial Wire JTAG Debug Port (SWJ-DP)
 - Flash Patch and Breakpoint (FPB) unit for implementing breakpoints
 - Data Watchpoint and Trace (DWT) unit for implementing watchpoints, trigger resources, and system profiling
 - Instrumentation Trace Macrocell (ITM) for support of printf style debugging
 - Embedded Trace Macrocell (ETM) for instruction trace capture
 - Trace Port Interface Unit (TPIU) for bridging to a Trace Port Analyzer

See the *ARM® Debug Interface V5 Architecture Specification* for more information on the ARM JTAG controller.

4.1 Block Diagram

Figure 4-1. JTAG Module Block Diagram

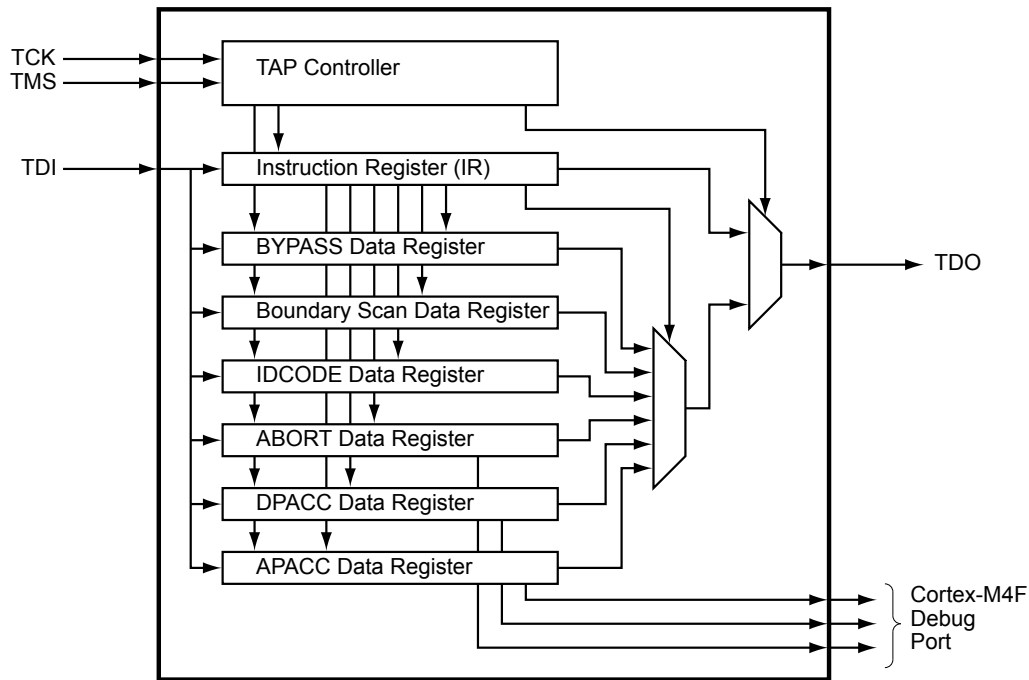

4.2 Signal Description

The following table lists the external signals of the JTAG/SWD controller and describes the function of each. The JTAG/SWD controller signals are alternate functions for some GPIO signals, however note that the reset state of the pins is for the JTAG/SWD function. The JTAG/SWD controller signals are under commit protection and require a special process to be configured as GPIOs, see “Commit Control” on page 630. The column in the table below titled “Pin Mux/Pin Assignment” lists the GPIO pin placement for the JTAG/SWD controller signals. The **AFSEL** bit in the **GPIO Alternate Function Select (GPIOAFSEL)** register (page 644) is set to choose the JTAG/SWD function. The number in parentheses is the encoding that must be programmed into the **PMC_n** field in the **GPIO Port Control (GPIOPTL)** register (page 661) to assign the JTAG/SWD controller signals to the specified GPIO port pin. For more information on configuring GPIOs, see “General-Purpose Input/Outputs (GPIOs)” on page 623.

Table 4-1. JTAG_SWD_SWO Signals (64LQFP)

Pin Name	Pin Number	Pin Mux / Pin Assignment	Pin Type	Buffer Type ^a	Description
SWCLK	52	PC0 (1)	I	TTL	JTAG/SWD CLK.
SWDIO	51	PC1 (1)	I/O	TTL	JTAG TMS and SWDIO.
SWO	49	PC3 (1)	O	TTL	JTAG TDO and SWO.
TCK	52	PC0 (1)	I	TTL	JTAG/SWD CLK.
TDI	50	PC2 (1)	I	TTL	JTAG TDI.
TDO	49	PC3 (1)	O	TTL	JTAG TDO and SWO.

Table 4-1. JTAG_SWD_SWO Signals (64LQFP) (continued)

Pin Name	Pin Number	Pin Mux / Pin Assignment	Pin Type	Buffer Type ^a	Description
TMS	51	PC1 (1)	I	TTL	JTAG TMS and SWDIO.

a. The TTL designation indicates the pin has TTL-compatible voltage levels.

4.3 Functional Description

A high-level conceptual drawing of the JTAG module is shown in Figure 4-1 on page 202. The JTAG module is composed of the Test Access Port (TAP) controller and serial shift chains with parallel update registers. The TAP controller is a simple state machine controlled by the TCK and TMS inputs. The current state of the TAP controller depends on the sequence of values captured on TMS at the rising edge of TCK. The TAP controller determines when the serial shift chains capture new data, shift data from TDI towards TDO, and update the parallel load registers. The current state of the TAP controller also determines whether the Instruction Register (IR) chain or one of the Data Register (DR) chains is being accessed.

The serial shift chains with parallel load registers are comprised of a single Instruction Register (IR) chain and multiple Data Register (DR) chains. The current instruction loaded in the parallel load register determines which DR chain is captured, shifted, or updated during the sequencing of the TAP controller.

Some instructions, like EXTEST and INTEST, operate on data currently in a DR chain and do not capture, shift, or update any of the chains. Instructions that are not implemented decode to the BYPASS instruction to ensure that the serial path between TDI and TDO is always connected (see Table 4-3 on page 209 for a list of implemented instructions).

See “JTAG and Boundary Scan” on page 1325 for JTAG timing diagrams.

Note: Of all the possible reset sources, only Power-On reset (POR) and the assertion of the $\overline{\text{RST}}$ input have any effect on the JTAG module. The pin configurations are reset by both the $\overline{\text{RST}}$ input and POR, whereas the internal JTAG logic is only reset with POR. See “Reset Sources” on page 214 for more information on reset.

4.3.1 JTAG Interface Pins

The JTAG interface consists of four standard pins: TCK, TMS, TDI, and TDO. These pins and their associated state after a power-on reset or reset caused by the $\overline{\text{RST}}$ input are given in Table 4-2. Detailed information on each pin follows.

Note: The following pins are configured as JTAG port pins out of reset. Refer to “General-Purpose Input/Outputs (GPIOs)” on page 623 for information on how to reprogram the configuration of these pins.

Table 4-2. JTAG Port Pins State after Power-On Reset or $\overline{\text{RST}}$ assertion

Pin Name	Data Direction	Internal Pull-Up	Internal Pull-Down	Drive Strength	Drive Value
TCK	Input	Enabled	Disabled	N/A	N/A
TMS	Input	Enabled	Disabled	N/A	N/A
TDI	Input	Enabled	Disabled	N/A	N/A
TDO	Output	Enabled	Disabled	2-mA driver	High-Z

4.3.1.1 Test Clock Input (TCK)

The TCK pin is the clock for the JTAG module. This clock is provided so the test logic can operate independently of any other system clocks and to ensure that multiple JTAG TAP controllers that are daisy-chained together can synchronously communicate serial test data between components. During normal operation, TCK is driven by a free-running clock with a nominal 50% duty cycle. When necessary, TCK can be stopped at 0 or 1 for extended periods of time. While TCK is stopped at 0 or 1, the state of the TAP controller does not change and data in the JTAG Instruction and Data Registers is not lost.

By default, the internal pull-up resistor on the TCK pin is enabled after reset, assuring that no clocking occurs if the pin is not driven from an external source. The internal pull-up and pull-down resistors can be turned off to save internal power as long as the TCK pin is constantly being driven by an external source (see page 650 and page 652).

4.3.1.2 Test Mode Select (TMS)

The TMS pin selects the next state of the JTAG TAP controller. TMS is sampled on the rising edge of TCK. Depending on the current TAP state and the sampled value of TMS, the next state may be entered. Because the TMS pin is sampled on the rising edge of TCK, the *IEEE Standard 1149.1* expects the value on TMS to change on the falling edge of TCK.

Holding TMS high for five consecutive TCK cycles drives the TAP controller state machine to the Test-Logic-Reset state. When the TAP controller enters the Test-Logic-Reset state, the JTAG module and associated registers are reset to their default values. This procedure should be performed to initialize the JTAG controller. The JTAG Test Access Port state machine can be seen in its entirety in Figure 4-2 on page 205.

By default, the internal pull-up resistor on the TMS pin is enabled after reset. Changes to the pull-up resistor settings on GPIO Port C should ensure that the internal pull-up resistor remains enabled on PC1/TMS; otherwise JTAG communication could be lost (see page 650).

4.3.1.3 Test Data Input (TDI)

The TDI pin provides a stream of serial information to the IR chain and the DR chains. TDI is sampled on the rising edge of TCK and, depending on the current TAP state and the current instruction, may present this data to the proper shift register chain. Because the TDI pin is sampled on the rising edge of TCK, the *IEEE Standard 1149.1* expects the value on TDI to change on the falling edge of TCK.

By default, the internal pull-up resistor on the TDI pin is enabled after reset. Changes to the pull-up resistor settings on GPIO Port C should ensure that the internal pull-up resistor remains enabled on PC2/TDI; otherwise JTAG communication could be lost (see page 650).

4.3.1.4 Test Data Output (TDO)

The TDO pin provides an output stream of serial information from the IR chain or the DR chains. The value of TDO depends on the current TAP state, the current instruction, and the data in the chain being accessed. In order to save power when the JTAG port is not being used, the TDO pin is placed in an inactive drive state when not actively shifting out data. Because TDO can be connected to the TDI of another controller in a daisy-chain configuration, the *IEEE Standard 1149.1* expects the value on TDO to change on the falling edge of TCK.

By default, the internal pull-up resistor on the TDO pin is enabled after reset, assuring that the pin remains at a constant logic level when the JTAG port is not being used. The internal pull-up and

pull-down resistors can be turned off to save internal power if a High-Z output value is acceptable during certain TAP controller states (see page 650 and page 652).

4.3.2 JTAG TAP Controller

The JTAG TAP controller state machine is shown in Figure 4-2. The TAP controller state machine is reset to the Test-Logic-Reset state on the assertion of a Power-On-Reset (POR). In order to reset the JTAG module after the microcontroller has been powered on, the TMS input must be held HIGH for five TCK clock cycles, resetting the TAP controller and all associated JTAG chains. Asserting the correct sequence on the TMS pin allows the JTAG module to shift in new instructions, shift in data, or idle during extended testing sequences. For detailed information on the function of the TAP controller and the operations that occur in each state, please refer to *IEEE Standard 1149.1*.

Figure 4-2. Test Access Port State Machine

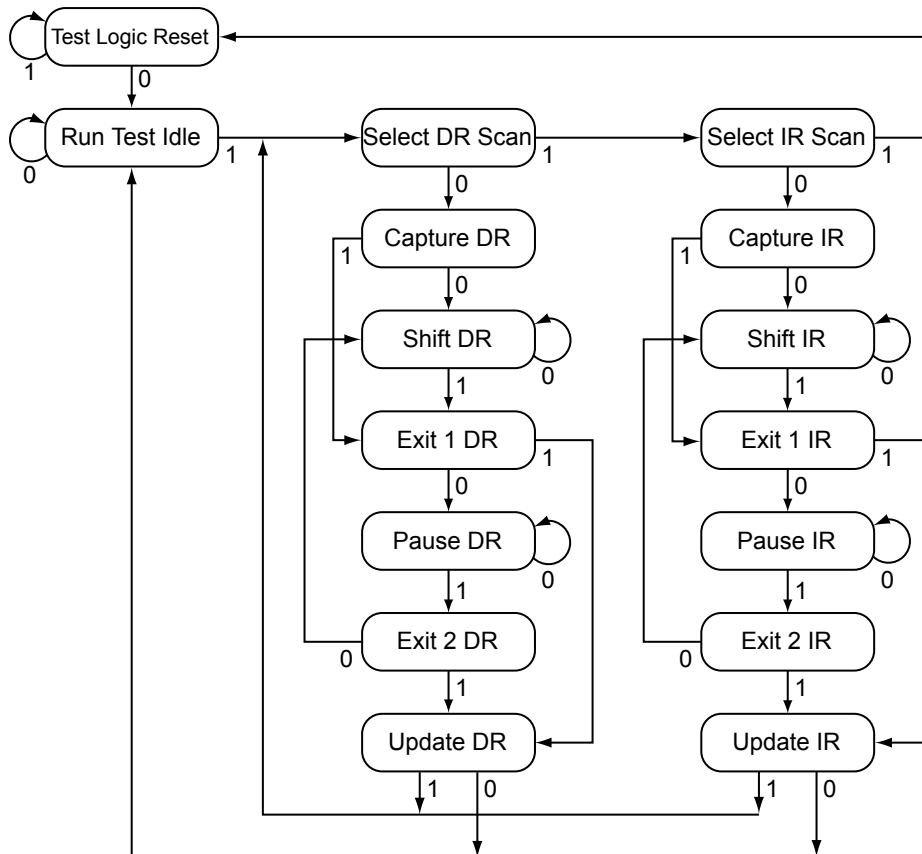

4.3.3 Shift Registers

The Shift Registers consist of a serial shift register chain and a parallel load register. The serial shift register chain samples specific information during the TAP controller's CAPTURE states and allows this information to be shifted out on TDO during the TAP controller's SHIFT states. While the sampled data is being shifted out of the chain on TDO, new data is being shifted into the serial shift register on TDI. This new data is stored in the parallel load register during the TAP controller's UPDATE states. Each of the shift registers is discussed in detail in "Register Descriptions" on page 208.

4.3.4 Operational Considerations

Certain operational parameters must be considered when using the JTAG module. Because the JTAG pins can be programmed to be GPIOs, board configuration and reset conditions on these pins must be considered. In addition, because the JTAG module has integrated ARM Serial Wire Debug, the method for switching between these two operational modes is described below.

4.3.4.1 GPIO Functionality

When the microcontroller is reset with either a POR or $\overline{\text{RST}}$, the JTAG/SWD port pins default to their JTAG/SWD configurations. The default configuration includes enabling digital functionality ($\text{DEN}[3:0]$ set in the **Port C GPIO Digital Enable (GPIODEN)** register), enabling the pull-up resistors ($\text{PUE}[3:0]$ set in the **Port C GPIO Pull-Up Select (GPIOPUR)** register), disabling the pull-down resistors ($\text{PDE}[3:0]$ cleared in the **Port C GPIO Pull-Down Select (GPIOPDR)** register) and enabling the alternate hardware function ($\text{AFSEL}[3:0]$ set in the **Port C GPIO Alternate Function Select (GPIOAFSEL)** register) on the JTAG/SWD pins. See page 644, page 650, page 652, and page 655.

It is possible for software to configure these pins as GPIOs after reset by clearing $\text{AFSEL}[3:0]$ in the **Port C GPIOAFSEL** register. If the user does not require the JTAG/SWD port for debugging or board-level testing, this provides four more GPIOs for use in the design.

Caution – It is possible to create a software sequence that prevents the debugger from connecting to the Stellaris microcontroller. If the program code loaded into flash immediately changes the JTAG pins to their GPIO functionality, the debugger may not have enough time to connect and halt the controller before the JTAG pin functionality switches. As a result, the debugger may be locked out of the part. This issue can be avoided with a software routine that restores JTAG functionality based on an external or software trigger.

The GPIO commit control registers provide a layer of protection against accidental programming of critical hardware peripherals. Protection is provided for the GPIO pins that can be used as the four JTAG/SWD pins ($\text{PC}[3:0]$) and the NMI pin (PD7 and PF0). Writes to protected bits of the **GPIO Alternate Function Select (GPIOAFSEL)** register (see page 644), **GPIO Pull Up Select (GPIOPUR)** register (see page 650), **GPIO Pull-Down Select (GPIOPDR)** register (see page 652), and **GPIO Digital Enable (GPIODEN)** register (see page 655) are not committed to storage unless the **GPIO Lock (GPIOLOCK)** register (see page 657) has been unlocked and the appropriate bits of the **GPIO Commit (GPIOCR)** register (see page 658) have been set.

4.3.4.2 Communication with JTAG/SWD

Because the debug clock and the system clock can be running at different frequencies, care must be taken to maintain reliable communication with the JTAG/SWD interface. In the Capture-DR state, the result of the previous transaction, if any, is returned, together with a 3-bit ACK response. Software should check the ACK response to see if the previous operation has completed before initiating a new transaction. Alternatively, if the system clock is at least 8 times faster than the debug clock (TCK or SWCLK), the previous operation has enough time to complete and the ACK bits do not have to be checked.

4.3.4.3 Recovering a "Locked" Microcontroller

Note: Performing the sequence below restores the non-volatile registers discussed in “Non-Volatile Register Programming” on page 508 to their factory default values. The mass erase of the Flash memory caused by the sequence below occurs prior to the non-volatile registers being restored.

In addition, the EEPROM is erased and its wear-leveling counters are returned to factory default values when performing the sequence below.

If software configures any of the JTAG/SWD pins as GPIO and loses the ability to communicate with the debugger, there is a debug port unlock sequence that can be used to recover the microcontroller. Performing a total of ten JTAG-to-SWD and SWD-to-JTAG switch sequences while holding the microcontroller in reset mass erases the Flash memory. The debug port unlock sequence is:

1. Assert and hold the $\overline{\text{RST}}$ signal.
2. Apply power to the device.
3. Perform steps 1 and 2 of the JTAG-to-SWD switch sequence on the section called “JTAG-to-SWD Switching” on page 208.
4. Perform steps 1 and 2 of the SWD-to-JTAG switch sequence on the section called “SWD-to-JTAG Switching” on page 208.
5. Perform steps 1 and 2 of the JTAG-to-SWD switch sequence.
6. Perform steps 1 and 2 of the SWD-to-JTAG switch sequence.
7. Perform steps 1 and 2 of the JTAG-to-SWD switch sequence.
8. Perform steps 1 and 2 of the SWD-to-JTAG switch sequence.
9. Perform steps 1 and 2 of the JTAG-to-SWD switch sequence.
10. Perform steps 1 and 2 of the SWD-to-JTAG switch sequence.
11. Perform steps 1 and 2 of the JTAG-to-SWD switch sequence.
12. Perform steps 1 and 2 of the SWD-to-JTAG switch sequence.
13. Release the $\overline{\text{RST}}$ signal.
14. Wait 400 ms.
15. Power-cycle the microcontroller.

4.3.4.4 ARM Serial Wire Debug (SWD)

In order to seamlessly integrate the ARM Serial Wire Debug (SWD) functionality, a serial-wire debugger must be able to connect to the Cortex-M4F core without having to perform, or have any knowledge of, JTAG cycles. This integration is accomplished with a SWD preamble that is issued before the SWD session begins.

The switching preamble used to enable the SWD interface of the SWJ-DP module starts with the TAP controller in the Test-Logic-Reset state. From here, the preamble sequences the TAP controller through the following states: Run Test Idle, Select DR, Select IR, Test Logic Reset, Test Logic Reset, Run Test Idle, Run Test Idle, Select DR, Select IR, Test Logic Reset, Test Logic Reset, Run Test Idle, Run Test Idle, Select DR, Select IR, and Test Logic Reset states.

Stepping through this sequence of the TAP state machine enables the SWD interface and disables the JTAG interface. For more information on this operation and the SWD interface, see the *ARM® Debug Interface V5 Architecture Specification*.

Because this sequence is a valid series of JTAG operations that could be issued, the ARM JTAG TAP controller is not fully compliant to the *IEEE Standard 1149.1*. This instance is the only one

where the ARM JTAG TAP controller does not meet full compliance with the specification. Due to the low probability of this sequence occurring during normal operation of the TAP controller, it should not affect normal performance of the JTAG interface.

JTAG-to-SWD Switching

To switch the operating mode of the Debug Access Port (DAP) from JTAG to SWD mode, the external debug hardware must send the switching preamble to the microcontroller. The 16-bit TMS command for switching to SWD mode is defined as b1110.0111.1001.1110, transmitted LSB first. This command can also be represented as 0xE79E when transmitted LSB first. The complete switch sequence should consist of the following transactions on the TCK/SWCLK and TMS/SWDIO signals:

1. Send at least 50 TCK/SWCLK cycles with TMS/SWDIO High to ensure that both JTAG and SWD are in their reset/idle states.
2. Send the 16-bit JTAG-to-SWD switch command, 0xE79E, on TMS.
3. Send at least 50 TCK/SWCLK cycles with TMS/SWDIO High to ensure that if SWJ-DP was already in SWD mode, the SWD goes into the line reset state before sending the switch sequence.

SWD-to-JTAG Switching

To switch the operating mode of the Debug Access Port (DAP) from SWD to JTAG mode, the external debug hardware must send a switch command to the microcontroller. The 16-bit TMS command for switching to JTAG mode is defined as b1110.0111.0011.1100, transmitted LSB first. This command can also be represented as 0xE73C when transmitted LSB first. The complete switch sequence should consist of the following transactions on the TCK/SWCLK and TMS/SWDIO signals:

1. Send at least 50 TCK/SWCLK cycles with TMS/SWDIO High to ensure that both JTAG and SWD are in their reset/idle states.
2. Send the 16-bit SWD-to-JTAG switch command, 0xE73C, on TMS.
3. Send at least 50 TCK/SWCLK cycles with TMS/SWDIO High to ensure that if SWJ-DP was already in JTAG mode, the JTAG goes into the Test Logic Reset state before sending the switch sequence.

4.4 Initialization and Configuration

After a Power-On-Reset or an external reset ($\overline{\text{RST}}$), the JTAG pins are automatically configured for JTAG communication. No user-defined initialization or configuration is needed. However, if the user application changes these pins to their GPIO function, they must be configured back to their JTAG functionality before JTAG communication can be restored. To return the pins to their JTAG functions, enable the four JTAG pins (PC[3:0]) for their alternate function using the **GPIOAFSEL** register. In addition to enabling the alternate functions, any other changes to the GPIO pad configurations on the four JTAG pins (PC[3:0]) should be returned to their default settings.

4.5 Register Descriptions

The registers in the JTAG TAP Controller or Shift Register chains are not memory mapped and are not accessible through the on-chip Advanced Peripheral Bus (APB). Instead, the registers within the JTAG controller are all accessed serially through the TAP Controller. These registers include the Instruction Register and the six Data Registers.

4.5.1 Instruction Register (IR)

The JTAG TAP Instruction Register (IR) is a four-bit serial scan chain connected between the JTAG TDI and TDO pins with a parallel load register. When the TAP Controller is placed in the correct states, bits can be shifted into the IR. Once these bits have been shifted into the chain and updated, they are interpreted as the current instruction. The decode of the IR bits is shown in Table 4-3. A detailed explanation of each instruction, along with its associated Data Register, follows.

Table 4-3. JTAG Instruction Register Commands

IR[3:0]	Instruction	Description
0x0	EXTEST	Drives the values preloaded into the Boundary Scan Chain by the SAMPLE/PRELOAD instruction onto the pads.
0x1	INTEST	Drives the values preloaded into the Boundary Scan Chain by the SAMPLE/PRELOAD instruction into the controller.
0x2	SAMPLE / PRELOAD	Captures the current I/O values and shifts the sampled values out of the Boundary Scan Chain while new preload data is shifted in.
0x8	ABORT	Shifts data into the ARM Debug Port Abort Register.
0xA	DPACC	Shifts data into and out of the ARM DP Access Register.
0xB	APACC	Shifts data into and out of the ARM AC Access Register.
0xE	IDCODE	Loads manufacturing information defined by the <i>IEEE Standard 1149.1</i> into the IDCODE chain and shifts it out.
0xF	BYPASS	Connects TDI to TDO through a single Shift Register chain.
All Others	Reserved	Defaults to the BYPASS instruction to ensure that TDI is always connected to TDO.

4.5.1.1 EXTEST Instruction

The EXTEST instruction is not associated with its own Data Register chain. Instead, the EXTEST instruction uses the data that has been preloaded into the Boundary Scan Data Register using the SAMPLE/PRELOAD instruction. When the EXTEST instruction is present in the Instruction Register, the preloaded data in the Boundary Scan Data Register associated with the outputs and output enables are used to drive the GPIO pads rather than the signals coming from the core. With tests that drive known values out of the controller, this instruction can be used to verify connectivity. While the EXTEST instruction is present in the Instruction Register, the Boundary Scan Data Register can be accessed to sample and shift out the current data and load new data into the Boundary Scan Data Register.

4.5.1.2 INTEST Instruction

The INTEST instruction is not associated with its own Data Register chain. Instead, the INTEST instruction uses the data that has been preloaded into the Boundary Scan Data Register using the SAMPLE/PRELOAD instruction. When the INTEST instruction is present in the Instruction Register, the preloaded data in the Boundary Scan Data Register associated with the inputs are used to drive the signals going into the core rather than the signals coming from the GPIO pads. With tests that drive known values into the controller, this instruction can be used for testing. It is important to note that although the RST input pin is on the Boundary Scan Data Register chain, it is only observable. While the INTEST instruction is present in the Instruction Register, the Boundary Scan Data Register can be accessed to sample and shift out the current data and load new data into the Boundary Scan Data Register.

4.5.1.3 SAMPLE/PRELOAD Instruction

The SAMPLE/PRELOAD instruction connects the Boundary Scan Data Register chain between `TDI` and `TDO`. This instruction samples the current state of the pad pins for observation and preloads new test data. Each GPIO pad has an associated input, output, and output enable signal. When the TAP controller enters the Capture DR state during this instruction, the input, output, and output-enable signals to each of the GPIO pads are captured. These samples are serially shifted out on `TDO` while the TAP controller is in the Shift DR state and can be used for observation or comparison in various tests.

While these samples of the inputs, outputs, and output enables are being shifted out of the Boundary Scan Data Register, new data is being shifted into the Boundary Scan Data Register from `TDI`. Once the new data has been shifted into the Boundary Scan Data Register, the data is saved in the parallel load registers when the TAP controller enters the Update DR state. This update of the parallel load register preloads data into the Boundary Scan Data Register that is associated with each input, output, and output enable. This preloaded data can be used with the EXTEST and INTEST instructions to drive data into or out of the controller. See “Boundary Scan Data Register” on page 211 for more information.

4.5.1.4 ABORT Instruction

The ABORT instruction connects the associated ABORT Data Register chain between `TDI` and `TDO`. This instruction provides read and write access to the ABORT Register of the ARM Debug Access Port (DAP). Shifting the proper data into this Data Register clears various error bits or initiates a DAP abort of a previous request. See the “ABORT Data Register” on page 212 for more information.

4.5.1.5 DPACC Instruction

The DPACC instruction connects the associated DPACC Data Register chain between `TDI` and `TDO`. This instruction provides read and write access to the DPACC Register of the ARM Debug Access Port (DAP). Shifting the proper data into this register and reading the data output from this register allows read and write access to the ARM debug and status registers. See “DPACC Data Register” on page 212 for more information.

4.5.1.6 APACC Instruction

The APACC instruction connects the associated APACC Data Register chain between `TDI` and `TDO`. This instruction provides read and write access to the APACC Register of the ARM Debug Access Port (DAP). Shifting the proper data into this register and reading the data output from this register allows read and write access to internal components and buses through the Debug Port. See “APACC Data Register” on page 212 for more information.

4.5.1.7 IDCODE Instruction

The IDCODE instruction connects the associated IDCODE Data Register chain between `TDI` and `TDO`. This instruction provides information on the manufacturer, part number, and version of the ARM core. This information can be used by testing equipment and debuggers to automatically configure input and output data streams. IDCODE is the default instruction loaded into the JTAG Instruction Register when a Power-On-Reset (POR) is asserted, or the Test-Logic-Reset state is entered. See “IDCODE Data Register” on page 211 for more information.

4.5.1.8 BYPASS Instruction

The BYPASS instruction connects the associated BYPASS Data Register chain between `TDI` and `TDO`. This instruction is used to create a minimum length serial path between the `TDI` and `TDO` ports. The BYPASS Data Register is a single-bit shift register. This instruction improves test efficiency by

allowing components that are not needed for a specific test to be bypassed in the JTAG scan chain by loading them with the BYPASS instruction. See “BYPASS Data Register” on page 211 for more information.

4.5.2 Data Registers

The JTAG module contains six Data Registers. These serial Data Register chains include: IDCODE, BYPASS, Boundary Scan, APACC, DPACC, and ABORT and are discussed in the following sections.

4.5.2.1 IDCODE Data Register

The format for the 32-bit IDCODE Data Register defined by the *IEEE Standard 1149.1* is shown in Figure 4-3. The standard requires that every JTAG-compliant microcontroller implement either the IDCODE instruction or the BYPASS instruction as the default instruction. The LSB of the IDCODE Data Register is defined to be a 1 to distinguish it from the BYPASS instruction, which has an LSB of 0. This definition allows auto-configuration test tools to determine which instruction is the default instruction.

The major uses of the JTAG port are for manufacturer testing of component assembly and program development and debug. To facilitate the use of auto-configuration debug tools, the IDCODE instruction outputs a value of 0x4BA0.0477. This value allows the debuggers to automatically configure themselves to work correctly with the Cortex-M4F during debug.

Figure 4-3. IDCODE Register Format

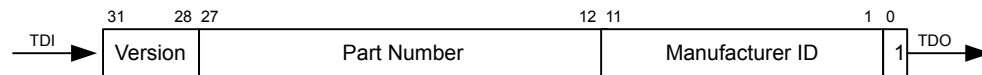

4.5.2.2 BYPASS Data Register

The format for the 1-bit BYPASS Data Register defined by the *IEEE Standard 1149.1* is shown in Figure 4-4. The standard requires that every JTAG-compliant microcontroller implement either the BYPASS instruction or the IDCODE instruction as the default instruction. The LSB of the BYPASS Data Register is defined to be a 0 to distinguish it from the IDCODE instruction, which has an LSB of 1. This definition allows auto-configuration test tools to determine which instruction is the default instruction.

Figure 4-4. BYPASS Register Format

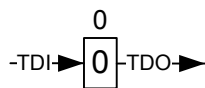

4.5.2.3 Boundary Scan Data Register

The format of the Boundary Scan Data Register is shown in Figure 4-5. Each GPIO pin, starting with a GPIO pin next to the JTAG port pins, is included in the Boundary Scan Data Register. Each GPIO pin has three associated digital signals that are included in the chain. These signals are input, output, and output enable, and are arranged in that order as shown in the figure.

When the Boundary Scan Data Register is accessed with the SAMPLE/PRELOAD instruction, the input, output, and output enable from each digital pad are sampled and then shifted out of the chain

to be verified. The sampling of these values occurs on the rising edge of TCK in the Capture DR state of the TAP controller. While the sampled data is being shifted out of the Boundary Scan chain in the Shift DR state of the TAP controller, new data can be preloaded into the chain for use with the EXTEST and INTEST instructions. The EXTEST instruction forces data out of the controller, and the INTEST instruction forces data into the controller.

Figure 4-5. Boundary Scan Register Format

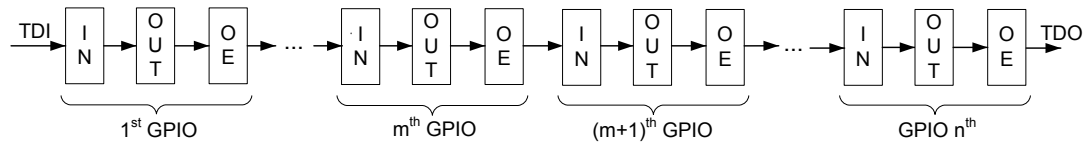

4.5.2.4 APACC Data Register

The format for the 35-bit APACC Data Register defined by ARM is described in the *ARM® Debug Interface V5 Architecture Specification*.

4.5.2.5 DPACC Data Register

The format for the 35-bit DPACC Data Register defined by ARM is described in the *ARM® Debug Interface V5 Architecture Specification*.

4.5.2.6 ABORT Data Register

The format for the 35-bit ABORT Data Register defined by ARM is described in the *ARM® Debug Interface V5 Architecture Specification*.

5 System Control

System control configures the overall operation of the device and provides information about the device. Configurable features include reset control, NMI operation, power control, clock control, and low-power modes.

5.1 Signal Description

The following table lists the external signals of the System Control module and describes the function of each. The **NMI** signal is the alternate function for two GPIO signals and functions as a GPIO after reset. PD7 and PF0 are under commit protection and require a special process to be configured as any alternate function or to subsequently return to the GPIO function, see “Commit Control” on page 630. The column in the table below titled “Pin Mux/Pin Assignment” lists the GPIO pin placement for the **NMI** signal. The **AFSEL** bit in the **GPIO Alternate Function Select (GPIOAFSEL)** register (page 644) should be set to choose the NMI function. The number in parentheses is the encoding that must be programmed into the **PMCn** field in the **GPIO Port Control (GPIOCTL)** register (page 661) to assign the **NMI** signal to the specified GPIO port pin. For more information on configuring GPIOs, see “General-Purpose Input/Outputs (GPIOs)” on page 623. The remaining signals (with the word “fixed” in the Pin Mux/Pin Assignment column) have a fixed pin assignment and function.

Table 5-1. System Control & Clocks Signals (64LQFP)

Pin Name	Pin Number	Pin Mux / Pin Assignment	Pin Type	Buffer Type ^a	Description
NMI	10 28	PD7 (8) PF0 (8)	I	TTL	Non-maskable interrupt.
OSC0	40	fixed	I	Analog	Main oscillator crystal input or an external clock reference input.
OSC1	41	fixed	O	Analog	Main oscillator crystal output. Leave unconnected when using a single-ended clock source.
RST	38	fixed	I	TTL	System reset input.

a. The TTL designation indicates the pin has TTL-compatible voltage levels.

5.2 Functional Description

The System Control module provides the following capabilities:

- Device identification, see “Device Identification” on page 213
- Local control, such as reset (see “Reset Control” on page 214), power (see “Power Control” on page 219) and clock control (see “Clock Control” on page 220)
- System control (Run, Sleep, and Deep-Sleep modes), see “System Control” on page 227

5.2.1 Device Identification

Several read-only registers provide software with information on the microcontroller, such as version, part number, memory sizes, and peripherals present on the device. The **Device Identification 0 (DID0)** (page 236) and **Device Identification 1 (DID1)** (page 238) registers provide details about the device's version, package, temperature range, and so on. The Peripheral Present registers starting at System Control offset 0x300, such as the **Watchdog Timer Peripheral Present (PPWD)** register, provide information on how many of each type of module are included on the device. Finally,

information about the capabilities of the on-chip peripherals are provided at offset 0xFC0 in each peripheral's register space in the Peripheral Properties registers, such as the **GPTM Peripheral Properties (GPTMPP)** register. Previous generations of Stellaris® devices used the **Device Capabilities (DC0-DC9)** registers for information about the peripherals and their capabilities. These registers are present on this device for backward software capability, but provide no information about peripherals that were not available on older devices.

5.2.2 Reset Control

This section discusses aspects of hardware functions during reset as well as system software requirements following the reset sequence.

5.2.2.1 Reset Sources

The LM4F231H5QR microcontroller has six sources of reset:

1. Power-on reset (POR) (see page 215).
2. External reset input pin (\overline{RST}) assertion (see page 215).
3. Internal brown-out (BOR) detector (see page 217).
4. Software-initiated reset (with the software reset registers) (see page 217).
5. A watchdog timer reset condition violation (see page 218).
6. MOSC failure (see page 219).

Table 5-2 provides a summary of results of the various reset operations.

Table 5-2. Reset Sources

Reset Source	Core Reset?	JTAG Reset?	On-Chip Peripherals Reset?
Power-On Reset	Yes	Yes	Yes
\overline{RST}	Yes	Pin Config Only	Yes
Brown-Out Reset	Yes	Pin Config Only	Yes
Software System Request Reset using the <code>SYSRESREQ</code> bit in the <code>APINT</code> register.	Yes	Pin Config Only	Yes
Software System Request Reset using the <code>VECTRESET</code> bit in the <code>APINT</code> register.	Yes	Pin Config Only	No
Software Peripheral Reset	No	Pin Config Only	Yes ^a
Watchdog Reset	Yes	Pin Config Only	Yes
MOSC Failure Reset	Yes	Pin Config Only	Yes

a. Programmable on a module-by-module basis using the Software Reset Control Registers.

After a reset, the **Reset Cause (RESC)** register is set with the reset cause. The bits in this register are sticky and maintain their state across multiple reset sequences, except when an internal POR is the cause, in which case, all the bits in the **RESC** register are cleared except for the POR indicator. A bit in the **RESC** register can be cleared by writing a 0.

At any reset that resets the core, the user has the opportunity to direct the core to execute the ROM Boot Loader or the application in Flash memory by using any GPIO signal as configured in the **Boot Configuration (BOOTCFG)** register.

At reset, the following sequence is performed:

1. The **BOOTCFG** register is read. If the **EN** bit is clear, the ROM Boot Loader is executed.
2. In the ROM Boot Loader, the status of the specified GPIO pin is compared with the specified polarity. If the status matches the specified polarity, the ROM is mapped to address 0x0000.0000 and execution continues out of the ROM Boot Loader.
3. If then **EN** bit is set or the status doesn't match the specified polarity, the data at address 0x0000.0004 is read, and if the data at this address is 0xFFFF.FFFF, the ROM is mapped to address 0x0000.0000 and execution continues out of the ROM Boot Loader.
4. If there is data at address 0x0000.0004 that is not 0xFFFF.FFFF, the stack pointer (**SP**) is loaded from Flash memory at address 0x0000.0000 and the program counter (**PC**) is loaded from address 0x0000.0004. The user application begins executing.

For example, if the **BOOTCFG** register is written and committed with the value of 0x0000.3C01, then **PB7** is examined at reset to determine if the ROM Boot Loader should be executed. If **PB7** is Low, the core unconditionally begins executing the ROM boot loader. If **PB7** is High, then the application in Flash memory is executed if the reset vector at location 0x0000.0004 is not 0xFFFF.FFFF. Otherwise, the ROM boot loader is executed.

5.2.2.2 Power-On Reset (POR)

Note: The JTAG controller can only be reset by the power-on reset.

The internal Power-On Reset (POR) circuit monitors the power supply voltage (V_{DD}) and generates a reset signal to all of the internal logic including JTAG when the power supply ramp reaches a threshold value (V_{TH}). The microcontroller must be operating within the specified operating parameters when the on-chip power-on reset pulse is complete (see “Power and Brown-Out” on page 1326). For applications that require the use of an external reset signal to hold the microcontroller in reset longer than the internal POR, the \overline{RST} input may be used as discussed in “External \overline{RST} Pin” on page 215.

The Power-On Reset sequence is as follows:

1. The microcontroller waits for internal POR to go inactive.
2. The internal reset is released and the core loads from memory the initial stack pointer, the initial program counter, and the first instruction designated by the program counter, and then begins execution.

The internal POR is only active on the initial power-up of the microcontroller. The Power-On Reset timing is shown in Figure 24-6 on page 1327.

5.2.2.3 External \overline{RST} Pin

Note: It is recommended that the trace for the \overline{RST} signal must be kept as short as possible. Be sure to place any components connected to the \overline{RST} signal as close to the microcontroller as possible.

If the application only uses the internal POR circuit, the \overline{RST} input must be connected to the power supply (V_{DD}) through an optional pull-up resistor (0 to 100K Ω) as shown in Figure 5-1 on page 216. The \overline{RST} input has filtering which requires a minimum pulse width in order for the reset pulse to be recognized, see Table 24-7 on page 1327.

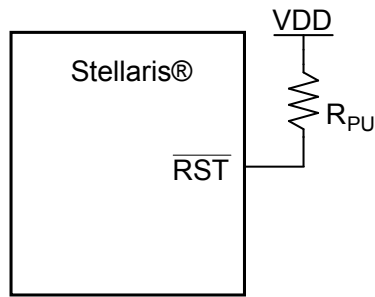
Figure 5-1. Basic $\overline{\text{RST}}$ Configuration

$R_{PU} = 0$ to 100 k Ω

The external reset pin ($\overline{\text{RST}}$) resets the microcontroller including the core and all the on-chip peripherals. The external reset sequence is as follows:

1. The external reset pin ($\overline{\text{RST}}$) is asserted for the duration specified by T_{MIN} and then de-asserted (see "Reset" on page 1327).
2. The internal reset is released and the core loads from memory the initial stack pointer, the initial program counter, and the first instruction designated by the program counter, and then begins execution.

To improve noise immunity and/or to delay reset at power up, the $\overline{\text{RST}}$ input may be connected to an RC network as shown in Figure 5-2 on page 216.

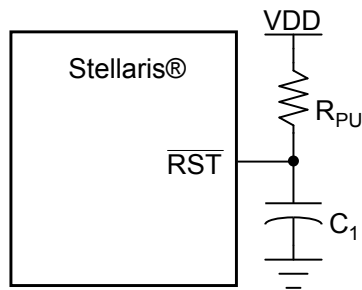
Figure 5-2. External Circuitry to Extend Power-On Reset

$R_{PU} = 1$ k Ω to 100 k Ω

$C_1 = 1$ nF to 10 μ F

If the application requires the use of an external reset switch, Figure 5-3 on page 217 shows the proper circuitry to use.

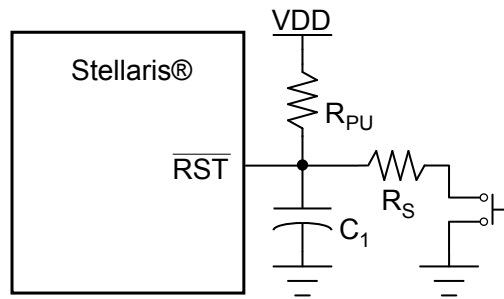
Figure 5-3. Reset Circuit Controlled by Switch

Typical $R_{PU} = 10 \text{ k}\Omega$

Typical $R_S = 470 \Omega$

$C_1 = 10 \text{ nF}$

The R_{PU} and C_1 components define the power-on delay.

The external reset timing is shown in Figure 24-8 on page 1328.

5.2.2.4 Brown-Out Reset (BOR)

The microcontroller provides a brown-out detection circuit that triggers if the power supply (V_{DD}) drops below a brown-out threshold voltage (V_{BTH}). If a brown-out condition is detected, the system may generate an interrupt or a system reset. The default condition is to generate an interrupt, so BOR must be enabled. Brown-out resets are controlled with the **Power-On and Brown-Out Reset Control (PBORCTL)** register. The $BORIOR$ bit in the **PBORCTL** register must be set for a brown-out condition to trigger a reset; if $BORIOR$ is clear, an interrupt is generated.

The brown-out reset sequence is as follows:

1. When V_{DD} drops below V_{BTH} , an internal BOR condition is set.
2. If the BOR condition exists, an internal reset is asserted.
3. The internal reset is released and the microcontroller fetches and loads the initial stack pointer, the initial program counter, the first instruction designated by the program counter, and begins execution.

The result of a brown-out reset is equivalent to that of an assertion of the external \overline{RST} input, and the reset is held active until the proper V_{DD} level is restored. The **RESC** register can be examined in the reset interrupt handler to determine if a Brown-Out condition was the cause of the reset, thus allowing software to determine what actions are required to recover.

The internal Brown-Out Reset timing is shown in Figure 24-7 on page 1327.

5.2.2.5 Software Reset

Software can reset a specific peripheral or generate a reset to the entire microcontroller.

Peripherals can be individually reset by software via peripheral-specific reset registers available beginning at System Control offset 0x500 (for example the **Watchdog Timer Software Reset (SRWD)** register). If the bit position corresponding to a peripheral is set and subsequently cleared, the peripheral is reset.

The entire microcontroller, including the core, can be reset by software by setting the `SYSRESREQ` bit in the **Application Interrupt and Reset Control (APINT)** register. The software-initiated system reset sequence is as follows:

1. A software microcontroller reset is initiated by setting the `SYSRESREQ` bit.
2. An internal reset is asserted.
3. The internal reset is deasserted and the microcontroller loads from memory the initial stack pointer, the initial program counter, and the first instruction designated by the program counter, and then begins execution.

The core only can be reset by software by setting the `VECTRESET` bit in the **APINT** register. The software-initiated core reset sequence is as follows:

1. A core reset is initiated by setting the `VECTRESET` bit.
2. An internal reset is asserted.
3. The internal reset is deasserted and the microcontroller loads from memory the initial stack pointer, the initial program counter, and the first instruction designated by the program counter, and then begins execution.

The software-initiated system reset timing is shown in Figure 24-9 on page 1328.

5.2.2.6 Watchdog Timer Reset

The Watchdog Timer module's function is to prevent system hangs. The LM4F231H5QR microcontroller has two Watchdog Timer modules in case one watchdog clock source fails. One watchdog is run off the system clock and the other is run off the Precision Internal Oscillator (PIOSC). Each module operates in the same manner except that because the PIOSC watchdog timer module is in a different clock domain, register accesses must have a time delay between them. The watchdog timer can be configured to generate an interrupt or a non-maskable interrupt to the microcontroller on its first time-out and to generate a reset on its second time-out.

After the watchdog's first time-out event, the 32-bit watchdog counter is reloaded with the value of the **Watchdog Timer Load (WDTLOAD)** register and resumes counting down from that value. If the timer counts down to zero again before the first time-out interrupt is cleared, and the reset signal has been enabled, the watchdog timer asserts its reset signal to the microcontroller. The watchdog timer reset sequence is as follows:

1. The watchdog timer times out for the second time without being serviced.
2. An internal reset is asserted.
3. The internal reset is released and the microcontroller loads from memory the initial stack pointer, the initial program counter, and the first instruction designated by the program counter, and then begins execution.

For more information on the Watchdog Timer module, see "Watchdog Timers" on page 747.

The watchdog reset timing is shown in Figure 24-10 on page 1328.

5.2.3 Non-Maskable Interrupt

The microcontroller has four sources of non-maskable interrupt (NMI):

- The assertion of the NMI signal
- A main oscillator verification error
- The NMISET bit in the **Interrupt Control and State (INTCTRL)** register in the Cortex™-M4F (see page 161).
- The Watchdog module time-out interrupt when the INTTYPE bit in the **Watchdog Control (WDTCTL)** register is set (see page 753).

Software must check the cause of the interrupt in order to distinguish among the sources.

5.2.3.1 NMI Pin

The NMI signal is an alternate function for either GPIO port pin PD7 or PF0. The alternate function must be enabled in the GPIO for the signal to be used as an interrupt, as described in “General-Purpose Input/Outputs (GPIOs)” on page 623. Note that enabling the NMI alternate function requires the use of the GPIO lock and commit function just like the GPIO port pins associated with JTAG/SWD functionality, see page 658. The active sense of the NMI signal is High; asserting the enabled NMI signal above V_{IH} initiates the NMI interrupt sequence.

5.2.3.2 Main Oscillator Verification Failure

The LM4F231H5QR microcontroller provides a main oscillator verification circuit that generates an error condition if the oscillator is running too fast or too slow. If the main oscillator verification circuit is enabled and a failure occurs, either a power-on reset is generated and control is transferred to the NMI handler, or an interrupt is generated. The MOSCIM bit in the **MOSCCTL** register determines which action occurs. In either case, the system clock source is automatically switched to the PIOSC. If a MOSC failure reset occurs, the NMI handler is used to address the main oscillator verification failure because the necessary code can be removed from the general reset handler, speeding up reset processing. The detection circuit is enabled by setting the CVAL bit in the **Main Oscillator Control (MOSCCTL)** register. The main oscillator verification error is indicated in the main oscillator fail status (MOSCFAIL) bit in the **Reset Cause (RESC)** register. The main oscillator verification circuit action is described in more detail in “Main Oscillator Verification Circuit” on page 226.

5.2.4 Power Control

The Stellaris microcontroller provides an integrated LDO regulator that is used to provide power to the majority of the microcontroller's internal logic. Figure 5-4 shows the power architecture.

An external LDO may not be used.

Note: VDDA must be supplied with a voltage that meets the specification in Table 24-2 on page 1323, or the microcontroller does not function properly. VDDA is the supply for all of the analog circuitry on the device, including the clock circuitry.

Figure 5-4. Power Architecture

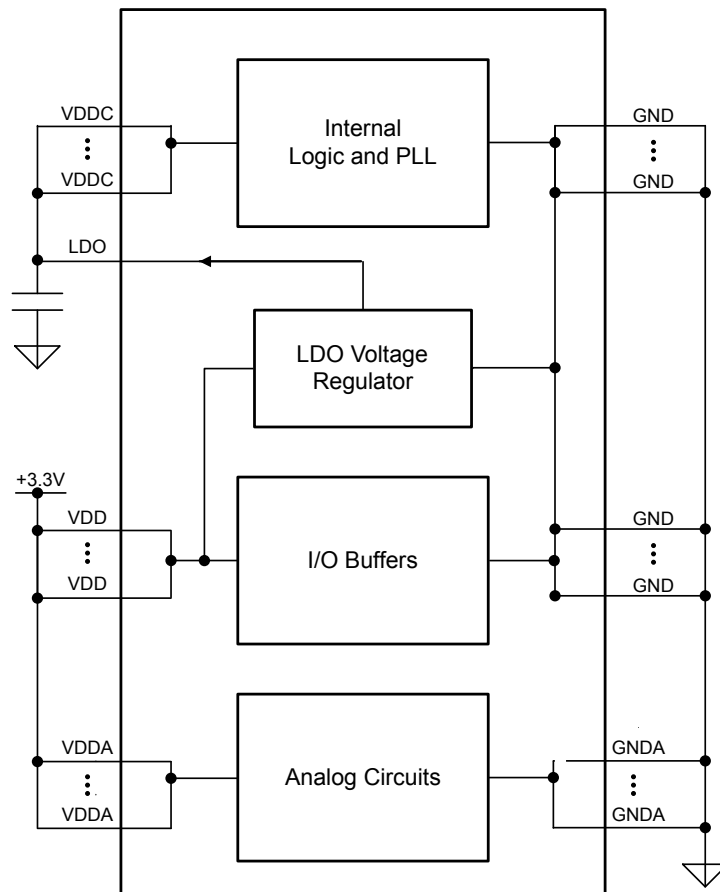

5.2.5 Clock Control

System control determines the control of clocks in this part.

5.2.5.1 Fundamental Clock Sources

There are multiple clock sources for use in the microcontroller:

- Precision Internal Oscillator (PIOSC).** The precision internal oscillator is an on-chip clock source that is the clock source the microcontroller uses during and following POR. It does not require the use of any external components and provides a clock that is 16 MHz \pm 1% at room temperature and \pm 3% across temperature. The PIOSC allows for a reduced system cost in applications that require an accurate clock source. If the main oscillator is required, software must enable the main oscillator following reset and allow the main oscillator to stabilize before changing the clock reference. Regardless of whether or not the PIOSC is the source for the system clock, the PIOSC can be configured to be the source for the ADC clock as well as the baud clock for the UART and SSI, see "System Control" on page 227.
- Main Oscillator (MOSC).** The main oscillator provides a frequency-accurate clock source by one of two means: an external single-ended clock source is connected to the OSC0 input pin, or an external crystal is connected across the OSC0 input and OSC1 output pins. If the PLL is being used, the crystal value must be one of the supported frequencies between 5 MHz to 25 MHz

(inclusive). If the PLL is not being used, the crystal may be any one of the supported frequencies between 4 MHz to 25 MHz. The single-ended clock source range is from DC through the specified speed of the microcontroller. The supported crystals are listed in the `XTAL` bit field in the **RCC** register (see page 249). Note that the MOSC provides the clock source for the USB PLL and must be connected to a crystal or an oscillator.

- **Internal 30-kHz Oscillator.** The internal 30-kHz oscillator provides an operational frequency of 30 kHz \pm 50%. It is intended for use during Deep-Sleep power-saving modes. This power-savings mode benefits from reduced internal switching and also allows the MOSC to be powered down.

The internal system clock (SysClk), is derived from any of the above sources plus two others: the output of the main internal PLL and the precision internal oscillator divided by four (4 MHz \pm 1%). The frequency of the PLL clock reference must be in the range of 5 MHz to 25 MHz (inclusive). Table 5-3 on page 221 shows how the various clock sources can be used in a system.

Table 5-3. Clock Source Options

Clock Source	Drive PLL?		Used as SysClk?	
	Yes	No	Yes	No
Precision Internal Oscillator	Yes	BYPASS = 0, OSCSRC = 0x1	Yes	BYPASS = 1, OSCSRC = 0x1
Precision Internal Oscillator divide by 4 (4 MHz \pm 1%)	No	-	Yes	BYPASS = 1, OSCSRC = 0x2
Main Oscillator	Yes	BYPASS = 0, OSCSRC = 0x0	Yes	BYPASS = 1, OSCSRC = 0x0
Internal 30-kHz Oscillator	No	-	Yes	BYPASS = 1, OSCSRC = 0x3

5.2.5.2 Clock Configuration

The **Run-Mode Clock Configuration (RCC)** and **Run-Mode Clock Configuration 2 (RCC2)** registers provide control for the system clock. The **RCC2** register is provided to extend fields that offer additional encodings over the **RCC** register. When used, the **RCC2** register field values are used by the logic over the corresponding field in the **RCC** register. In particular, **RCC2** provides for a larger assortment of clock configuration options. These registers control the following clock functionality:

- Source of clocks in sleep and deep-sleep modes
- System clock derived from PLL or other clock source
- Enabling/disabling of oscillators and PLL
- Clock divisors
- Crystal input selection

Important: Write the **RCC** register prior to writing the **RCC2** register. If a subsequent write to the **RCC** register is required, include another register access after writing the **RCC** register and before writing the **RCC2** register.

The configuration of the system clock must not be changed while an EEPROM operation is in process. Software must wait until the `WORKING` bit in the **EEPROM Done Status (EEDONE)** register is clear before making any changes to the system clock.

Figure 5-5 shows the logic for the main clock tree. The peripheral blocks are driven by the system clock signal and can be individually enabled/disabled. The ADC clock signal can be selected from

the PIOSC, the system clock if the PLL is disabled, or the PLL output divided down to 16 MHz if the PLL is enabled. The PWM clock signal is a synchronous divide of the system clock to provide the PWM circuit with more range (set with `PWMDIV` in `RCC`).

Note: If the ADC module is not using the PIOSC as the clock source, the system clock must be at least 16 MHz. When the USB module is in operation, MOSC must be the clock source, either with or without using the PLL, and the system clock must be at least 30 MHz.

Figure 5-5. Main Clock Tree

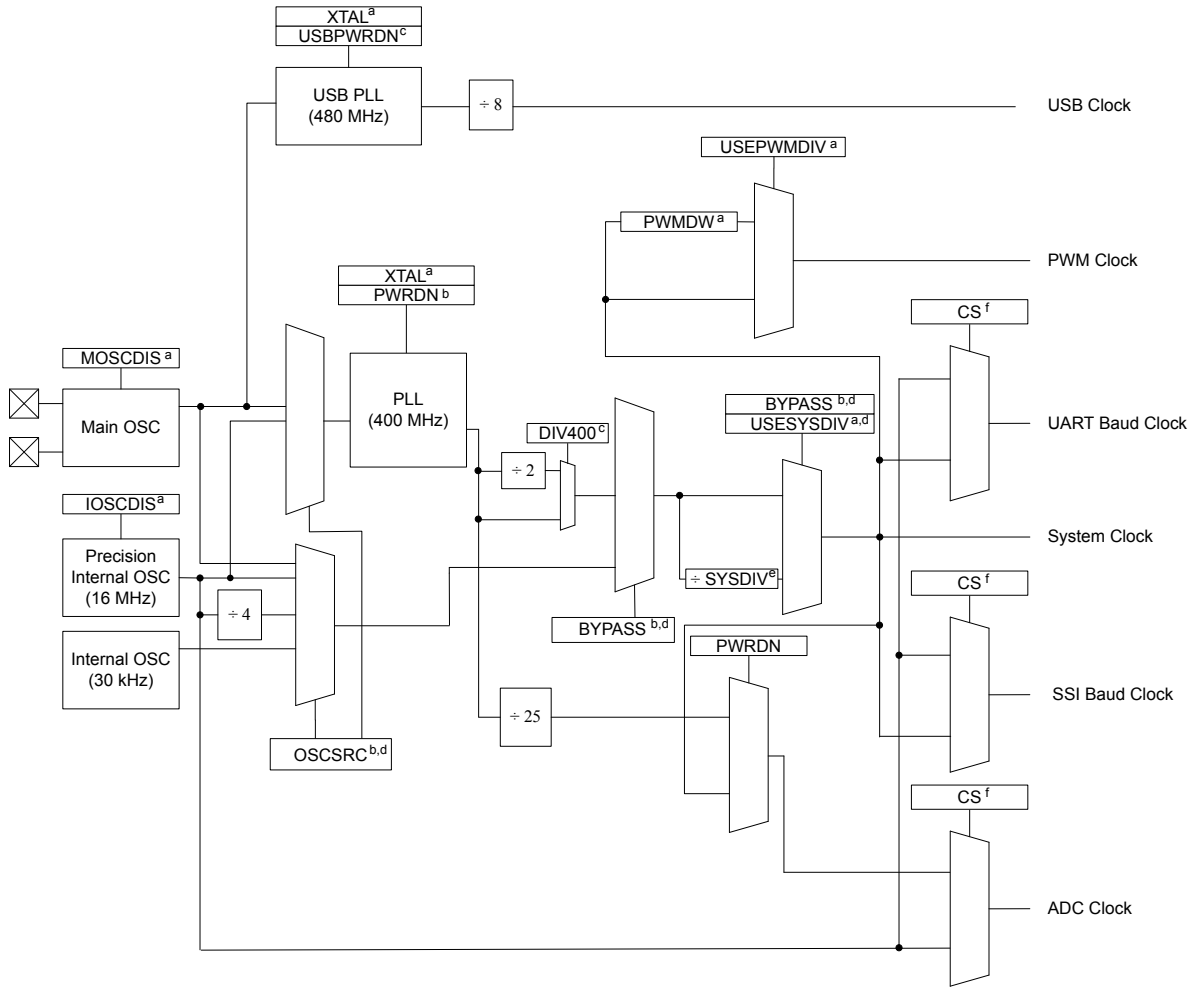

- Note:**
- a. Control provided by `RCC` register bit/field.
 - b. Control provided by `RCC` register bit/field or `RCC2` register bit/field, if overridden with `RCC2` register bit `USERCC2`.
 - c. Control provided by `RCC2` register bit/field.
 - d. Also may be controlled by `DSLCLKCFG` when in deep sleep mode.
 - e. Control provided by `RCC` register `SYSDIV` field, `RCC2` register `SYSDIV2` field if overridden with `USERCC2` bit, or [`SYSDIV2`,`SYSDIV2LSB`] if both `USERCC2` and `DIV400` bits are set.
 - f. Control provided by `UARTCC`, `SSICC`, and `ADCC` register field.

Communication Clock Sources

In addition to the main clock tree described above, the UART, and SSI modules all have a Clock Control register in the peripheral's register map at offset `0xFC8` that can be used to select the clock

source for the module's baud clock. Users can choose between the system clock, which is the default source for the baud clock, and the PIOSC. Note that there may be special considerations when using the PIOSC as the baud clock. For more information, see the Clock Control register description in the chapter describing the operation of the module.

Using the SYSDIV and SYSDIV2 Fields

In the **RCC** register, the **SYSDIV** field specifies which divisor is used to generate the system clock from either the PLL output or the oscillator source (depending on how the **BYPASS** bit in this register is configured). When using the PLL, the VCO frequency of 400 MHz is predivided by 2 before the divisor is applied. Table 5-4 shows how the **SYSDIV** encoding affects the system clock frequency, depending on whether the PLL is used (**BYPASS=0**) or another clock source is used (**BYPASS=1**). The divisor is equivalent to the **SYSDIV** encoding plus 1. For a list of possible clock sources, see Table 5-3 on page 221.

Table 5-4. Possible System Clock Frequencies Using the SYSDIV Field

SYSDIV	Divisor	Frequency (BYPASS=0)	Frequency (BYPASS=1)	StellarisWare® Parameter ^a
0x0	/1	reserved	Clock source frequency/2	SYSCCTL_SYSDIV_1 ^b
0x1	/2	reserved	Clock source frequency/2	SYSCCTL_SYSDIV_2
0x2	/3	66.67 MHz	Clock source frequency/3	SYSCCTL_SYSDIV_3
0x3	/4	50 MHz	Clock source frequency/4	SYSCCTL_SYSDIV_4
0x4	/5	40 MHz	Clock source frequency/5	SYSCCTL_SYSDIV_5
0x5	/6	33.33 MHz	Clock source frequency/6	SYSCCTL_SYSDIV_6
0x6	/7	28.57 MHz	Clock source frequency/7	SYSCCTL_SYSDIV_7
0x7	/8	25 MHz	Clock source frequency/8	SYSCCTL_SYSDIV_8
0x8	/9	22.22 MHz	Clock source frequency/9	SYSCCTL_SYSDIV_9
0x9	/10	20 MHz	Clock source frequency/10	SYSCCTL_SYSDIV_10
0xA	/11	18.18 MHz	Clock source frequency/11	SYSCCTL_SYSDIV_11
0xB	/12	16.67 MHz	Clock source frequency/12	SYSCCTL_SYSDIV_12
0xC	/13	15.38 MHz	Clock source frequency/13	SYSCCTL_SYSDIV_13
0xD	/14	14.29 MHz	Clock source frequency/14	SYSCCTL_SYSDIV_14
0xE	/15	13.33 MHz	Clock source frequency/15	SYSCCTL_SYSDIV_15
0xF	/16	12.5 MHz (default)	Clock source frequency/16	SYSCCTL_SYSDIV_16

a. This parameter is used in functions such as SysCtlClockSet() in the Stellaris Peripheral Driver Library.

b. SYSCCTL_SYSDIV_1 does not set the USESYSDIV bit. As a result, using this parameter without enabling the PLL results in the system clock having the same frequency as the clock source.

The **SYSDIV2** field in the **RCC2** register is 2 bits wider than the **SYSDIV** field in the **RCC** register so that additional larger divisors up to /64 are possible, allowing a lower system clock frequency for improved Deep Sleep power consumption. When using the PLL, the VCO frequency of 400 MHz is predivided by 2 before the divisor is applied. The divisor is equivalent to the **SYSDIV2** encoding plus 1. Table 5-5 shows how the **SYSDIV2** encoding affects the system clock frequency, depending on whether the PLL is used (**BYPASS2=0**) or another clock source is used (**BYPASS2=1**). For a list of possible clock sources, see Table 5-3 on page 221.

Table 5-5. Examples of Possible System Clock Frequencies Using the SYSDIV2 Field

SYSDIV2	Divisor	Frequency (BYPASS2=0)	Frequency (BYPASS2=1)	StellarisWare Parameter ^a
0x00	/1	reserved	Clock source frequency/2	SYSCCTL_SYSDIV_1 ^b

Table 5-5. Examples of Possible System Clock Frequencies Using the SYSDIV2 Field (continued)

SYSDIV2	Divisor	Frequency (BYPASS2=0)	Frequency (BYPASS2=1)	StellarisWare Parameter ^a
0x01	/2	reserved	Clock source frequency/2	SYSCTL_SYSDIV_2
0x02	/3	66.67 MHz	Clock source frequency/3	SYSCTL_SYSDIV_3
0x03	/4	50 MHz	Clock source frequency/4	SYSCTL_SYSDIV_4
0x04	/5	40 MHz	Clock source frequency/5	SYSCTL_SYSDIV_5
...
0x09	/10	20 MHz	Clock source frequency/10	SYSCTL_SYSDIV_10
...
0x3F	/64	3.125 MHz	Clock source frequency/64	SYSCTL_SYSDIV_64

a. This parameter is used in functions such as SysCtlClockSet() in the Stellaris Peripheral Driver Library.

b. SYSCTL_SYSDIV_1 does not set the USESYSDIV bit. As a result, using this parameter without enabling the PLL results in the system clock having the same frequency as the clock source.

To allow for additional frequency choices when using the PLL, the DIV400 bit is provided along with the SYSDIV2LSB bit. When the DIV400 bit is set, bit 22 becomes the LSB for SYSDIV2. In this situation, the divisor is equivalent to the (SYSDIV2 encoding with SYSDIV2LSB appended) plus one. Table 5-6 shows the frequency choices when DIV400 is set. When the DIV400 bit is clear, SYSDIV2LSB is ignored, and the system clock frequency is determined as shown in Table 5-5 on page 223.

Table 5-6. Examples of Possible System Clock Frequencies with DIV400=1

SYSDIV2	SYSDIV2LSB	Divisor	Frequency (BYPASS2=0) ^a	StellarisWare Parameter ^b
0x00	reserved	/2	reserved	-
0x01	0	/3	reserved	-
	1	/4	reserved	-
0x02	0	/5	80 MHz	SYSCTL_SYSDIV_2_5
	1	/6	66.67 MHz	SYSCTL_SYSDIV_3
0x03	0	/7	reserved	-
	1	/8	50 MHz	SYSCTL_SYSDIV_4
0x04	0	/9	44.44 MHz	SYSCTL_SYSDIV_4_5
	1	/10	40 MHz	SYSCTL_SYSDIV_5
...
0x3F	0	/127	3.15 MHz	SYSCTL_SYSDIV_63_5
	1	/128	3.125 MHz	SYSCTL_SYSDIV_64

a. Note that DIV400 and SYSDIV2LSB are only valid when BYPASS2=0.

b. This parameter is used in functions such as SysCtlClockSet() in the Stellaris Peripheral Driver Library.

5.2.5.3 Precision Internal Oscillator Operation (PIOSC)

The microcontroller powers up with the PIOSC running. If another clock source is desired, the PIOSC must remain enabled as it is used for internal functions. The PIOSC can only be disabled during Deep-Sleep mode. It can be powered down by setting the IOSCDIS bit in the **RCC** register.

The PIOSC generates a 16-MHz clock with a $\pm 1\%$ accuracy at room temperatures. Across the extended temperature range, the accuracy is $\pm 3\%$. At the factory, the PIOSC is set to 16 MHz at

room temperature, however, the frequency can be trimmed for other voltage or temperature conditions using software in one of two ways:

- Default calibration: clear the `UTEN` bit and set the `UPDATE` bit in the **Precision Internal Oscillator Calibration (PIOCCAL)** register.
- User-defined calibration: The user can program the `UT` value to adjust the PIOSC frequency. As the `UT` value increases, the generated period increases. To commit a new `UT` value, first set the `UTEN` bit, then program the `UT` field, and then set the `UPDATE` bit. The adjustment finishes within a few clock periods and is glitch free.

5.2.5.4 Crystal Configuration for the Main Oscillator (MOSC)

The main oscillator supports the use of a select number of crystals from 4 to 25 MHz.

The `XTAL` bit in the **RCC** register (see page 249) describes the available crystal choices and default programming values.

Software configures the **RCC** register `XTAL` field with the crystal number. If the PLL is used in the design, the `XTAL` field value is internally translated to the PLL settings.

5.2.5.5 Main PLL Frequency Configuration

The main PLL is disabled by default during power-on reset and is enabled later by software if required. Software specifies the output divisor to set the system clock frequency and enables the main PLL to drive the output. The PLL operates at 400 MHz, but is divided by two prior to the application of the output divisor, unless the `DIV400` bit in the **RCC2** register is set.

To configure the PIOSC to be the clock source for the main PLL, program the `OSCR2` field in the **Run-Mode Clock Configuration 2 (RCC2)** register to be 0x1.

If the main oscillator provides the clock reference to the main PLL, the translation provided by hardware and used to program the PLL is available for software in the **PLL Frequency n (PLLFRQn)** registers (see page 264). The internal translation provides a translation within $\pm 1\%$ of the targeted PLL VCO frequency. Table 24-10 on page 1329 shows the actual PLL frequency and error for a given crystal choice.

The Crystal Value field (`XTAL`) in the **Run-Mode Clock Configuration (RCC)** register (see page 249) describes the available crystal choices and default programming of the **PLLFRQn** registers. Any time the `XTAL` field changes, the new settings are translated and the internal PLL settings are updated.

5.2.5.6 USB PLL Frequency Configuration

The USB PLL is disabled by default during power-on reset and is enabled later by software. The USB PLL must be enabled and running for proper USB function. The main oscillator is the only clock reference for the USB PLL. The USB PLL is enabled by clearing the `USBPWRDN` bit of the **RCC2** register. The `XTAL` bit field (Crystal Value) of the **RCC** register describes the available crystal choices. The main oscillator must be connected to one of the following crystal values in order to correctly generate the USB clock: 5, 6, 8, 10, 12, 16, 18, 20, 24, or 25 MHz. Only these crystals provide the necessary USB PLL VCO frequency to conform with the USB timing specifications.

5.2.5.7 PLL Modes

Both PLLs have two modes of operation: Normal and Power-Down

- Normal: The PLL multiplies the input clock reference and drives the output.

- Power-Down: Most of the PLL internal circuitry is disabled and the PLL does not drive the output.

The modes are programmed using the **RCC/RCC2** register fields (see page 249 and page 256).

5.2.5.8 PLL Operation

If a PLL configuration is changed, the PLL output frequency is unstable until it reconverges (relocks) to the new setting. The time between the configuration change and relock is T_{READY} (see Table 24-9 on page 1329). During the relock time, the affected PLL is not usable as a clock reference. Software can poll the `LOCK` bit in the **PLL Status (PLLSTAT)** register to determine when the PLL has locked.

Either PLL is changed by one of the following:

- Change to the `XTAL` value in the **RCC** register—writes of the same value do not cause a relock.
- Change in the PLL from Power-Down to Normal mode.

A counter clocked by the system clock is used to measure the T_{READY} requirement. The down counter is set to 0x200 if the PLL is powering up. If the `M` or `N` values in the **PLLFREQn** registers are changed, the counter is set to 0xC0. Hardware is provided to keep the PLL from being used as a system clock until the T_{READY} condition is met after one of the two changes above. It is the user's responsibility to have a stable clock source (like the main oscillator) before the **RCC/RCC2** register is switched to use the PLL.

If the main PLL is enabled and the system clock is switched to use the PLL in one step, the system control hardware continues to clock the microcontroller from the oscillator selected by the **RCC/RCC2** register until the main PLL is stable (T_{READY} time met), after which it changes to the PLL. Software can use many methods to ensure that the system is clocked from the main PLL, including periodically polling the `PLLLRIS` bit in the **Raw Interrupt Status (RIS)** register, and enabling the PLL Lock interrupt.

The USB PLL is not protected during the lock time (T_{READY}), and software should ensure that the USB PLL has locked before using the interface. Software can use many methods to ensure the T_{READY} period has passed, including periodically polling the `USBPLLLRIS` bit in the **Raw Interrupt Status (RIS)** register, and enabling the USB PLL Lock interrupt.

5.2.5.9 Main Oscillator Verification Circuit

The clock control includes circuitry to ensure that the main oscillator is running at the appropriate frequency. The circuit monitors the main oscillator frequency and signals if the frequency is outside of the allowable band of attached crystals.

The detection circuit is enabled using the `CVAL` bit in the **Main Oscillator Control (MOSCCTL)** register. If this circuit is enabled and detects an error, and if the `MOSCIM` bit in the **MOSCCTL** register is clear, then the following sequence is performed by the hardware:

1. The `MOSCFAIL` bit in the **Reset Cause (RESC)** register is set.
2. The system clock is switched from the main oscillator to the `PIOSC`.
3. An internal power-on reset is initiated.
4. Reset is de-asserted and the processor is directed to the NMI handler during the reset sequence.

if the `MOSCIM` bit in the **MOSCCTL** register is set, then the following sequence is performed by the hardware:

1. The system clock is switched from the main oscillator to the PIOSC.
2. The MOFRIS bit in the RIS register is set to indicate a MOSC failure.

5.2.6 System Control

For power-savings purposes, the peripheral-specific **RCGCx**, **SCGCx**, and **DCGCx** registers (for example, **RCGCWD**) control the clock gating logic for that peripheral or block in the system while the microcontroller is in Run, Sleep, and Deep-Sleep mode, respectively. These registers are located in the System Control register map starting at offsets 0x600, 0x700, and 0x800, respectively. There must be a delay of 3 system clocks after a peripheral module clock is enabled in the **RCGC** register before any module registers are accessed.

Important: To support legacy software, the **RCGCn**, **SCGCn**, and **DCGCn** registers are available at offsets 0x100 - 0x128. A write to any of these legacy registers also writes the corresponding bit in the peripheral-specific **RCGCx**, **SCGCx**, and **DCGCx** registers. Software must use the peripheral-specific registers to support modules that are not present in the legacy registers. It is recommended that new software use the new registers and not rely on legacy operation.

If software uses a peripheral-specific register to write a legacy peripheral (such as TIMER0), the write causes proper operation, but the value of that bit is not reflected in the legacy register. Any bits that are changed by writing to a legacy register can be read back correctly with a read of the legacy register. If software uses both legacy and peripheral-specific register accesses, the peripheral-specific registers must be accessed by read-modify-write operations that affect only peripherals that are not present in the legacy registers. In this manner, both the peripheral-specific and legacy registers have coherent information.

There are three levels of operation for the microcontroller defined as:

- Run mode
- Sleep mode
- Deep-Sleep mode

The following sections describe the different modes in detail.

Caution – If the Cortex-M4F Debug Access Port (DAP) has been enabled, and the device wakes from a low power sleep or deep-sleep mode, the core may start executing code before all clocks to peripherals have been restored to their Run mode configuration. The DAP is usually enabled by software tools accessing the JTAG or SWD interface when debugging or flash programming. If this condition occurs, a Hard Fault is triggered when software accesses a peripheral with an invalid clock.

A software delay loop can be used at the beginning of the interrupt routine that is used to wake up a system from a WFI (Wait For Interrupt) instruction. This stalls the execution of any code that accesses a peripheral register that might cause a fault. This loop can be removed for production software as the DAP is most likely not enabled during normal execution.

Because the DAP is disabled by default (power on reset), the user can also power cycle the device. The DAP is not enabled unless it is enabled through the JTAG or SWD interface.

5.2.6.1 Run Mode

In Run mode, the microcontroller actively executes code. Run mode provides normal operation of the processor and all of the peripherals that are currently enabled by the the peripheral-specific **RCGC** registers. The system clock can be any of the available clock sources including the PLL.

5.2.6.2 Sleep Mode

In Sleep mode, the clock frequency of the active peripherals is unchanged, but the processor and the memory subsystem are not clocked and therefore no longer execute code. Sleep mode is entered by the Cortex-M4F core executing a **WFI** (Wait for Interrupt) instruction. Any properly configured interrupt event in the system brings the processor back into Run mode. See “Power Management” on page 115 for more details.

Peripherals are clocked that are enabled in the peripheral-specific **SCGC** registers when auto-clock gating is enabled (see the **RCC** register) or the the peripheral-specific **RCGC** registers when the auto-clock gating is disabled. The system clock has the same source and frequency as that during Run mode.

Important: Before executing the **WFI** instruction, software must confirm that the EEPROM is not busy by checking to see that the **WORKING** bit in the **EEPROM Done Status (EEDONE)** register is clear.

5.2.6.3 Deep-Sleep Mode

In Deep-Sleep mode, the clock frequency of the active peripherals may change (depending on the Run mode clock configuration) in addition to the processor clock being stopped. An interrupt returns the microcontroller to Run mode from one of the sleep modes; the sleep modes are entered on request from the code. Deep-Sleep mode is entered by first setting the **SLEEPDEEP** bit in the **System Control (SYSCTRL)** register (see page 167) and then executing a **WFI** instruction. Any properly configured interrupt event in the system brings the processor back into Run mode. See “Power Management” on page 115 for more details.

The Cortex-M4F processor core and the memory subsystem are not clocked in Deep-Sleep mode. Peripherals are clocked that are enabled in the the peripheral-specific **DCGC** registers when auto-clock gating is enabled (see the **RCC** register) or the peripheral-specific **RCGC** registers when auto-clock gating is disabled. The system clock source is specified in the **DSLCLKCFG** register. When the **DSLCLKCFG** register is used, the internal oscillator source is powered up, if necessary, and other clocks are powered down. If the PLL is running at the time of the **WFI** instruction, hardware powers the PLL down and overrides the **SYSDIV** field of the active **RCC/RCC2** register, to be determined by the **DSDIVORIDE** setting in the **DSLCLKCFG** register, up to /16 or /64 respectively. When the Deep-Sleep exit event occurs, hardware brings the system clock back to the source and frequency it had at the onset of Deep-Sleep mode before enabling the clocks that had been stopped during the Deep-Sleep duration. If the **PIOSC** is used as the PLL reference clock source, it may continue to provide the clock during Deep-Sleep. See page 260.

Important: Before executing the **WFI** instruction, software must confirm that the EEPROM is not busy by checking to see that the **WORKING** bit in the **EEPROM Done Status (EEDONE)** register is clear.

To provide the lowest possible Deep-Sleep power consumption as well the ability to wake the processor from a peripheral without reconfiguring the peripheral for a change in clock, some of the communications modules have a Clock Control register at offset 0xFC8 in the module register space. The **CS** field in the Clock Control register allows the user to select the **PIOSC** as the clock source for the module's baud clock. When the microcontroller enters Deep-Sleep mode, the **PIOSC** becomes

the source for the module clock as well, which allows the transmit and receive FIFOs to continue operation while the part is in Deep-Sleep. Figure 5-6 on page 229 shows how the clocks are selected.

Figure 5-6. Module Clock Selection

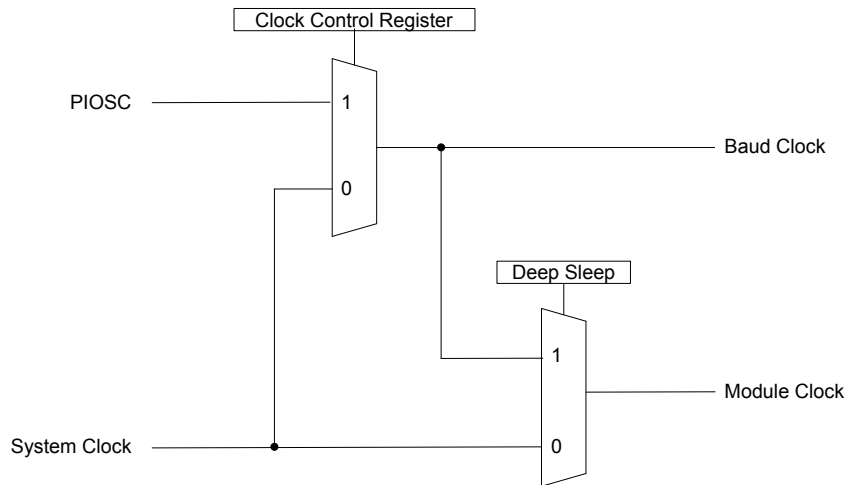

5.3 Initialization and Configuration

The PLL is configured using direct register writes to the **RCC/RCC2** register. If the **RCC2** register is being used, the **USERCC2** bit must be set and the appropriate **RCC2** bit/field is used. The steps required to successfully change the PLL-based system clock are:

1. Bypass the PLL and system clock divider by setting the **BYPASS** bit and clearing the **USESYS** bit in the **RCC** register, thereby configuring the microcontroller to run off a "raw" clock source and allowing for the new PLL configuration to be validated before switching the system clock to the PLL.
2. Select the crystal value (**XTAL**) and oscillator source (**OSCSRC**), and clear the **PWRDN** bit in **RCC/RCC2**. Setting the **XTAL** field automatically pulls valid PLL configuration data for the appropriate crystal, and clearing the **PWRDN** bit powers and enables the PLL and its output.
3. Select the desired system divider (**SYSDIV**) in **RCC/RCC2** and set the **USESYS** bit in **RCC**. The **SYSDIV** field determines the system frequency for the microcontroller.
4. Wait for the PLL to lock by polling the **PLLLRIS** bit in the **Raw Interrupt Status (RIS)** register.
5. Enable use of the PLL by clearing the **BYPASS** bit in **RCC/RCC2**.

5.4 Register Map

Table 5-7 on page 230 lists the System Control registers, grouped by function. The offset listed is a hexadecimal increment to the register's address, relative to the System Control base address of 0x400F.E000.

Note: Spaces in the System Control register space that are not used are reserved for future or internal use. Software should not modify any reserved memory address.

Additional Flash and ROM registers defined in the System Control register space are described in the "Internal Memory" on page 501.

Table 5-7. System Control Register Map

Offset	Name	Type	Reset	Description	See page
System Control Registers					
0x000	DID0	RO	-	Device Identification 0	236
0x004	DID1	RO	-	Device Identification 1	238
0x030	PBORCTL	R/W	0x0000.0000	Brown-Out Reset Control	240
0x050	RIS	RO	0x0000.0000	Raw Interrupt Status	241
0x054	IMC	R/W	0x0000.0000	Interrupt Mask Control	243
0x058	MISC	R/W1C	0x0000.0000	Masked Interrupt Status and Clear	245
0x05C	RESC	R/W	-	Reset Cause	247
0x060	RCC	R/W	0x078E.3D51	Run-Mode Clock Configuration	249
0x06C	GPIOHBCTL	R/W	0x0000.7E00	GPIO High-Performance Bus Control	254
0x070	RCC2	R/W	0x07C0.6810	Run-Mode Clock Configuration 2	256
0x07C	MOSCCTL	R/W	0x0000.0000	Main Oscillator Control	259
0x144	DSLPLCKCFG	R/W	0x0780.0000	Deep Sleep Clock Configuration	260
0x14C	SYSPROP	RO	0x0000.1D31	System Properties	262
0x150	PIOSCCAL	R/W	0x0000.0000	Precision Internal Oscillator Calibration	263
0x160	PLLREQ0	RO	0x0000.0032	PLL Frequency 0	264
0x164	PLLREQ1	RO	0x0000.0001	PLL Frequency 1	265
0x168	PLLSTAT	RO	0x0000.0000	PLL Status	266
0x300	PPWD	RO	0x0000.0003	Watchdog Timer Peripheral Present	267
0x304	PPTIMER	RO	0x0000.003F	16/32-Bit General-Purpose Timer Peripheral Present	268
0x308	PPGPIO	RO	0x0000.007F	General-Purpose Input/Output Peripheral Present	270
0x30C	PPDMA	RO	0x0000.0001	Micro Direct Memory Access Peripheral Present	273
0x314	PPHIB	RO	0x0000.0000	Hibernation Peripheral Present	274
0x318	PPUART	RO	0x0000.00FF	Universal Asynchronous Receiver/Transmitter Peripheral Present	275
0x31C	PPSSI	RO	0x0000.000F	Synchronous Serial Interface Peripheral Present	277
0x320	PPI2C	RO	0x0000.003F	Inter-Integrated Circuit Peripheral Present	279
0x328	PPUSB	RO	0x0000.0001	Universal Serial Bus Peripheral Present	281
0x334	PPCAN	RO	0x0000.0003	Controller Area Network Peripheral Present	282
0x338	PPADC	RO	0x0000.0003	Analog-to-Digital Converter Peripheral Present	283
0x33C	PPACMP	RO	0x0000.0001	Analog Comparator Peripheral Present	284
0x340	PPPWM	RO	0x0000.0003	Pulse Width Modulator Peripheral Present	285

Table 5-7. System Control Register Map (continued)

Offset	Name	Type	Reset	Description	See page
0x344	PPQEI	RO	0x0000.0003	Quadrature Encoder Interface Peripheral Present	286
0x358	PPEEPROM	RO	0x0000.0001	EEPROM Peripheral Present	287
0x35C	PPWTIMER	RO	0x0000.003F	32/64-Bit Wide General-Purpose Timer Peripheral Present	288
0x500	SRWD	R/W	0x0000.0000	Watchdog Timer Software Reset	290
0x504	SRTIMER	R/W	0x0000.0000	16/32-Bit General-Purpose Timer Software Reset	292
0x508	SRGPIO	R/W	0x0000.0000	General-Purpose Input/Output Software Reset	294
0x50C	SRDMA	R/W	0x0000.0000	Micro Direct Memory Access Software Reset	296
0x518	SRUART	R/W	0x0000.0000	Universal Asynchronous Receiver/Transmitter Software Reset	297
0x51C	SRSSI	R/W	0x0000.0000	Synchronous Serial Interface Software Reset	299
0x520	SRI2C	R/W	0x0000.0000	Inter-Integrated Circuit Software Reset	301
0x528	SRUSB	R/W	0x0000.0000	Universal Serial Bus Software Reset	303
0x534	SRCAN	R/W	0x0000.0000	Controller Area Network Software Reset	304
0x538	SRADC	R/W	0x0000.0000	Analog-to-Digital Converter Software Reset	306
0x53C	SRACMP	R/W	0x0000.0000	Analog Comparator Software Reset	308
0x540	SRPWM	R/W	0x0000.0000	Pulse Width Modulator Software Reset	309
0x544	SRQEI	R/W	0x0000.0000	Quadrature Encoder Interface Software Reset	311
0x558	SREEEPROM	R/W	0x0000.0000	EEPROM Software Reset	313
0x55C	SRWTIMER	R/W	0x0000.0000	32/64-Bit Wide General-Purpose Timer Software Reset	314
0x600	RCGCWD	R/W	0x0000.0000	Watchdog Timer Run Mode Clock Gating Control	316
0x604	RCGCTIMER	R/W	0x0000.0000	16/32-Bit General-Purpose Timer Run Mode Clock Gating Control	317
0x608	RCGCGPIO	R/W	0x0000.0000	General-Purpose Input/Output Run Mode Clock Gating Control	319
0x60C	RCGCDMA	R/W	0x0000.0000	Micro Direct Memory Access Run Mode Clock Gating Control	321
0x618	RCGCUART	R/W	0x0000.0000	Universal Asynchronous Receiver/Transmitter Run Mode Clock Gating Control	322
0x61C	RCGCSSI	R/W	0x0000.0000	Synchronous Serial Interface Run Mode Clock Gating Control	324
0x620	RCGCI2C	R/W	0x0000.0000	Inter-Integrated Circuit Run Mode Clock Gating Control	326
0x628	RCGCUSB	R/W	0x0000.0000	Universal Serial Bus Run Mode Clock Gating Control	328
0x634	RCGCCAN	R/W	0x0000.0000	Controller Area Network Run Mode Clock Gating Control	329
0x638	RCGCADC	R/W	0x0000.0000	Analog-to-Digital Converter Run Mode Clock Gating Control	330

Table 5-7. System Control Register Map (continued)

Offset	Name	Type	Reset	Description	See page
0x63C	RCGCACMP	R/W	0x0000.0000	Analog Comparator Run Mode Clock Gating Control	331
0x640	RCGCPWM	R/W	0x0000.0000	Pulse Width Modulator Run Mode Clock Gating Control	332
0x644	RCGCQEI	R/W	0x0000.0000	Quadrature Encoder Interface Run Mode Clock Gating Control	333
0x658	RCGCEEPROM	R/W	0x0000.0000	EEPROM Run Mode Clock Gating Control	334
0x65C	RCGCWTIMER	R/W	0x0000.0000	32/64-Bit Wide General-Purpose Timer Run Mode Clock Gating Control	335
0x700	SCGCWD	R/W	0x0000.0000	Watchdog Timer Sleep Mode Clock Gating Control	337
0x704	SCGCTIMER	R/W	0x0000.0000	16/32-Bit General-Purpose Timer Sleep Mode Clock Gating Control	338
0x708	SCGCGPIO	R/W	0x0000.0000	General-Purpose Input/Output Sleep Mode Clock Gating Control	340
0x70C	SCGCDMA	R/W	0x0000.0000	Micro Direct Memory Access Sleep Mode Clock Gating Control	342
0x718	SCGCUART	R/W	0x0000.0000	Universal Asynchronous Receiver/Transmitter Sleep Mode Clock Gating Control	343
0x71C	SCGCSSI	R/W	0x0000.0000	Synchronous Serial Interface Sleep Mode Clock Gating Control	345
0x720	SCGCI2C	R/W	0x0000.0000	Inter-Integrated Circuit Sleep Mode Clock Gating Control	347
0x728	SCGCUSB	R/W	0x0000.0000	Universal Serial Bus Sleep Mode Clock Gating Control	349
0x734	SCGCCAN	R/W	0x0000.0000	Controller Area Network Sleep Mode Clock Gating Control	350
0x738	SCGCADC	R/W	0x0000.0000	Analog-to-Digital Converter Sleep Mode Clock Gating Control	351
0x73C	SCGCACMP	R/W	0x0000.0000	Analog Comparator Sleep Mode Clock Gating Control	352
0x740	SCGCPWM	R/W	0x0000.0000	Pulse Width Modulator Sleep Mode Clock Gating Control	353
0x744	SCGCQEI	R/W	0x0000.0000	Quadrature Encoder Interface Sleep Mode Clock Gating Control	354
0x758	SCGCEEPROM	R/W	0x0000.0000	EEPROM Sleep Mode Clock Gating Control	355
0x75C	SCGCWTIMER	R/W	0x0000.0000	32/64-Bit Wide General-Purpose Timer Sleep Mode Clock Gating Control	356
0x800	DCGCWD	R/W	0x0000.0000	Watchdog Timer Deep-Sleep Mode Clock Gating Control	358
0x804	DCGCTIMER	R/W	0x0000.0000	16/32-Bit General-Purpose Timer Deep-Sleep Mode Clock Gating Control	359
0x808	DCGCGPIO	R/W	0x0000.0000	General-Purpose Input/Output Deep-Sleep Mode Clock Gating Control	361
0x80C	DCGCDMA	R/W	0x0000.0000	Micro Direct Memory Access Deep-Sleep Mode Clock Gating Control	363

Table 5-7. System Control Register Map (continued)

Offset	Name	Type	Reset	Description	See page
0x818	DCGCUART	R/W	0x0000.0000	Universal Asynchronous Receiver/Transmitter Deep-Sleep Mode Clock Gating Control	364
0x81C	DCGCSSI	R/W	0x0000.0000	Synchronous Serial Interface Deep-Sleep Mode Clock Gating Control	366
0x820	DCGCI2C	R/W	0x0000.0000	Inter-Integrated Circuit Deep-Sleep Mode Clock Gating Control	368
0x828	DCGCUSB	R/W	0x0000.0000	Universal Serial Bus Deep-Sleep Mode Clock Gating Control	370
0x834	DCGCCAN	R/W	0x0000.0000	Controller Area Network Deep-Sleep Mode Clock Gating Control	371
0x838	DCGCADC	R/W	0x0000.0000	Analog-to-Digital Converter Deep-Sleep Mode Clock Gating Control	372
0x83C	DCGCACMP	R/W	0x0000.0000	Analog Comparator Deep-Sleep Mode Clock Gating Control	373
0x840	DCGCPWM	R/W	0x0000.0000	Pulse Width Modulator Deep-Sleep Mode Clock Gating Control	374
0x844	DCGCQEI	R/W	0x0000.0000	Quadrature Encoder Interface Deep-Sleep Mode Clock Gating Control	375
0x858	DCGCEEPROM	R/W	0x0000.0000	EEPROM Deep-Sleep Mode Clock Gating Control	376
0x85C	DCGCWTIMER	R/W	0x0000.0000	32/64-Bit Wide General-Purpose Timer Deep-Sleep Mode Clock Gating Control	377
0x900	PCWD	R/W	0x0000.0003	Watchdog Timer Power Control	379
0x904	PCTIMER	R/W	0x0000.003F	16/32-Bit General-Purpose Timer Power Control	381
0x908	PCGPIO	R/W	0x0000.7FFF	General-Purpose Input/Output Power Control	384
0x90C	PCDMA	R/W	0x0000.0001	Micro Direct Memory Access Power Control	387
0x918	PCUART	R/W	0x0000.00FF	Universal Asynchronous Receiver/Transmitter Power Control	388
0x91C	PCSSI	R/W	0x0000.000F	Synchronous Serial Interface Power Control	392
0x920	PCI2C	R/W	0x0000.003F	Inter-Integrated Circuit Power Control	394
0x928	PCUSB	R/W	0x0000.0001	Universal Serial Bus Power Control	397
0x934	PCCAN	R/W	0x0000.0003	Controller Area Network Power Control	398
0x938	PCADC	R/W	0x0000.0003	Analog-to-Digital Converter Power Control	400
0x93C	PCACMP	R/W	0x0000.0001	Analog Comparator Power Control	402
0x940	PCPWM	R/W	0x0000.0003	Pulse Width Modulator Power Control	403
0x944	PCQEI	R/W	0x0000.0003	Quadrature Encoder Interface Power Control	405
0x958	PCEEPROM	R/W	0x0000.0001	EEPROM Power Control	407
0x95C	PCWTIMER	R/W	0x0000.0000	32/64-Bit Wide General-Purpose Timer Power Control	408

Table 5-7. System Control Register Map (continued)

Offset	Name	Type	Reset	Description	See page
0xA00	PRWD	R/W	0x0000.0000	Watchdog Timer Peripheral Ready	411
0xA04	PRTIMER	R/W	0x0000.0000	16/32-Bit General-Purpose Timer Peripheral Ready	412
0xA08	PRGPIO	R/W	0x0000.0000	General-Purpose Input/Output Peripheral Ready	414
0xA0C	PRDMA	R/W	0x0000.0000	Micro Direct Memory Access Peripheral Ready	416
0xA18	PRUART	R/W	0x0000.0000	Universal Asynchronous Receiver/Transmitter Peripheral Ready	417
0xA1C	PRSSI	R/W	0x0000.0000	Synchronous Serial Interface Peripheral Ready	419
0xA20	PRI2C	R/W	0x0000.0000	Inter-Integrated Circuit Peripheral Ready	421
0xA28	PRUSB	R/W	0x0000.0000	Universal Serial Bus Peripheral Ready	423
0xA34	PRCAN	R/W	0x0000.0000	Controller Area Network Peripheral Ready	424
0xA38	PRADC	R/W	0x0000.0000	Analog-to-Digital Converter Peripheral Ready	425
0xA3C	PRACMP	R/W	0x0000.0000	Analog Comparator Peripheral Ready	426
0xA40	PRPWM	R/W	0x0000.0000	Pulse Width Modulator Peripheral Ready	427
0xA44	PRQEI	R/W	0x0000.0000	Quadrature Encoder Interface Peripheral Ready	428
0xA58	PREEPROM	R/W	0x0000.0000	EEPROM Peripheral Ready	429
0xA5C	PRWTIMER	R/W	0x0000.0000	32/64-Bit Wide General-Purpose Timer Peripheral Ready	430
System Control Legacy Registers					
0x008	DC0	RO	0x007F.007F	Device Capabilities 0	432
0x010	DC1	RO	0x1333.2FBF	Device Capabilities 1	434
0x014	DC2	RO	0x030F.F337	Device Capabilities 2	437
0x018	DC3	RO	0xBFFF.8FFF	Device Capabilities 3	440
0x01C	DC4	RO	0x0004.F07F	Device Capabilities 4	444
0x020	DC5	RO	0x0730.00FF	Device Capabilities 5	447
0x024	DC6	RO	0x0000.0013	Device Capabilities 6	449
0x028	DC7	RO	0xFFFF.FFFF	Device Capabilities 7	450
0x02C	DC8	RO	0x0FFF.0FFF	Device Capabilities 8	453
0x040	SRCR0	RO	0x0000.0000	Software Reset Control 0	456
0x044	SRCR1	RO	0x0000.0000	Software Reset Control 1	458
0x048	SRCR2	RO	0x0000.0000	Software Reset Control 2	461
0x100	RCGC0	RO	0x0000.0040	Run Mode Clock Gating Control Register 0	463
0x104	RCGC1	RO	0x0000.0000	Run Mode Clock Gating Control Register 1	467
0x108	RCGC2	RO	0x0000.0000	Run Mode Clock Gating Control Register 2	471

Table 5-7. System Control Register Map (continued)

Offset	Name	Type	Reset	Description	See page
0x110	SCGC0	RO	0x0000.0040	Sleep Mode Clock Gating Control Register 0	474
0x114	SCGC1	RO	0x0000.0000	Sleep Mode Clock Gating Control Register 1	477
0x118	SCGC2	RO	0x0000.0000	Sleep Mode Clock Gating Control Register 2	480
0x120	DCGC0	RO	0x0000.0040	Deep Sleep Mode Clock Gating Control Register 0	482
0x124	DCGC1	RO	0x0000.0000	Deep-Sleep Mode Clock Gating Control Register 1	485
0x128	DCGC2	RO	0x0000.0000	Deep Sleep Mode Clock Gating Control Register 2	488
0x190	DC9	RO	0x00FF.00FF	Device Capabilities 9	490
0x1A0	NVMSTAT	RO	0x0000.0001	Non-Volatile Memory Information	492

5.5 System Control Register Descriptions

All addresses given are relative to the System Control base address of 0x400F.E000. Registers provided for legacy software support only are listed in “System Control Legacy Register Descriptions” on page 431.

Register 1: Device Identification 0 (DID0), offset 0x000

This register identifies the version of the microcontroller. Each microcontroller is uniquely identified by the combined values of the CLASS field in the **DID0** register and the PARTNO field in the **DID1** register.

Device Identification 0 (DID0)

Base 0x400F.E000

Offset 0x000

Type RO, reset -

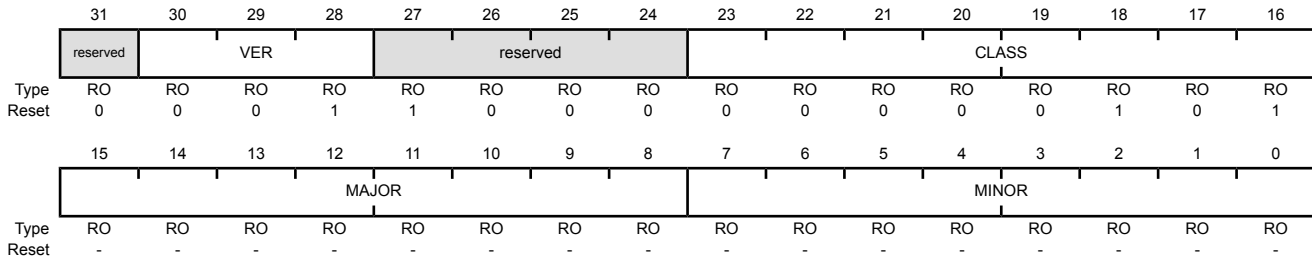

Bit/Field	Name	Type	Reset	Description				
31	reserved	RO	0	Software should not rely on the value of a reserved bit. To provide compatibility with future products, the value of a reserved bit should be preserved across a read-modify-write operation.				
30:28	VER	RO	0x01	<p>DID0 Version</p> <p>This field defines the DID0 register format version. The version number is numeric. The value of the VER field is encoded as follows (all other encodings are reserved):</p> <table border="1"> <thead> <tr> <th>Value</th> <th>Description</th> </tr> </thead> <tbody> <tr> <td>0x1</td> <td>Second version of the DID0 register format.</td> </tr> </tbody> </table>	Value	Description	0x1	Second version of the DID0 register format.
Value	Description							
0x1	Second version of the DID0 register format.							
27:24	reserved	RO	0x08	Software should not rely on the value of a reserved bit. To provide compatibility with future products, the value of a reserved bit should be preserved across a read-modify-write operation.				
23:16	CLASS	RO	0x05	<p>Device Class</p> <p>The CLASS field value identifies the internal design from which all mask sets are generated for all microcontrollers in a particular product line. The CLASS field value is changed for new product lines, for changes in fab process (for example, a remap or shrink), or any case where the MAJOR or MINOR fields require differentiation from prior microcontrollers. The value of the CLASS field is encoded as follows (all other encodings are reserved):</p> <table border="1"> <thead> <tr> <th>Value</th> <th>Description</th> </tr> </thead> <tbody> <tr> <td>0x05</td> <td>Stellaris® Blizzard-class microcontrollers</td> </tr> </tbody> </table>	Value	Description	0x05	Stellaris® Blizzard-class microcontrollers
Value	Description							
0x05	Stellaris® Blizzard-class microcontrollers							

Bit/Field	Name	Type	Reset	Description								
15:8	MAJOR	RO	-	<p>Major Revision</p> <p>This field specifies the major revision number of the microcontroller. The major revision reflects changes to base layers of the design. The major revision number is indicated in the part number as a letter (A for first revision, B for second, and so on). This field is encoded as follows:</p> <table border="1"> <thead> <tr> <th>Value</th> <th>Description</th> </tr> </thead> <tbody> <tr> <td>0x0</td> <td>Revision A (initial device)</td> </tr> <tr> <td>0x1</td> <td>Revision B (first base layer revision)</td> </tr> <tr> <td>0x2</td> <td>Revision C (second base layer revision)</td> </tr> </tbody> </table> <p>and so on.</p>	Value	Description	0x0	Revision A (initial device)	0x1	Revision B (first base layer revision)	0x2	Revision C (second base layer revision)
Value	Description											
0x0	Revision A (initial device)											
0x1	Revision B (first base layer revision)											
0x2	Revision C (second base layer revision)											
7:0	MINOR	RO	-	<p>Minor Revision</p> <p>This field specifies the minor revision number of the microcontroller. The minor revision reflects changes to the metal layers of the design. The MINOR field value is reset when the MAJOR field is changed. This field is numeric and is encoded as follows:</p> <table border="1"> <thead> <tr> <th>Value</th> <th>Description</th> </tr> </thead> <tbody> <tr> <td>0x0</td> <td>Initial device, or a major revision update.</td> </tr> <tr> <td>0x1</td> <td>First metal layer change.</td> </tr> <tr> <td>0x2</td> <td>Second metal layer change.</td> </tr> </tbody> </table> <p>and so on.</p>	Value	Description	0x0	Initial device, or a major revision update.	0x1	First metal layer change.	0x2	Second metal layer change.
Value	Description											
0x0	Initial device, or a major revision update.											
0x1	First metal layer change.											
0x2	Second metal layer change.											

Register 2: Device Identification 1 (DID1), offset 0x004

This register identifies the device family, part number, temperature range, pin count, and package type. Each microcontroller is uniquely identified by the combined values of the `CLASS` field in the `DID0` register and the `PARTNO` field in the `DID1` register.

Device Identification 1 (DID1)

Base 0x400F.E000

Offset 0x004

Type RO, reset -

	31	30	29	28	27	26	25	24	23	22	21	20	19	18	17	16
	VER				FAM				PARTNO							
Type	RO	RO	RO	RO	RO	RO	RO	RO	RO	RO	RO	RO	RO	RO	RO	RO
Reset	0	0	0	1	0	0	0	0	1	0	1	1	0	0	0	1
	15	14	13	12	11	10	9	8	7	6	5	4	3	2	1	0
	PINCOUNT			reserved				TEMP			PKG		ROHS	QUAL		
Type	RO	RO	RO	RO	RO	RO	RO	RO	RO	RO	RO	RO	RO	RO	RO	RO
Reset	0	1	1	0	0	0	0	0	0	0	1	0	1	1	-	-

Bit/Field	Name	Type	Reset	Description						
31:28	VER	RO	0x1	<p>DID1 Version</p> <p>This field defines the DID1 register format version. The version number is numeric. The value of the <code>VER</code> field is encoded as follows (all other encodings are reserved):</p> <table border="1"> <thead> <tr> <th>Value</th> <th>Description</th> </tr> </thead> <tbody> <tr> <td>0x0</td> <td>Initial DID1 register format definition, indicating a Stellaris LM3Snnn device.</td> </tr> <tr> <td>0x1</td> <td>Second version of the DID1 register format.</td> </tr> </tbody> </table>	Value	Description	0x0	Initial DID1 register format definition, indicating a Stellaris LM3Snnn device.	0x1	Second version of the DID1 register format.
Value	Description									
0x0	Initial DID1 register format definition, indicating a Stellaris LM3Snnn device.									
0x1	Second version of the DID1 register format.									
27:24	FAM	RO	0x0	<p>Family</p> <p>This field provides the family identification of the device within the Stellaris product portfolio. The value is encoded as follows (all other encodings are reserved):</p> <table border="1"> <thead> <tr> <th>Value</th> <th>Description</th> </tr> </thead> <tbody> <tr> <td>0x0</td> <td>Stellaris family of microcontrollers, that is, all devices with external part numbers starting with LM3S, LM4S, and LM4F.</td> </tr> </tbody> </table>	Value	Description	0x0	Stellaris family of microcontrollers, that is, all devices with external part numbers starting with LM3S, LM4S, and LM4F.		
Value	Description									
0x0	Stellaris family of microcontrollers, that is, all devices with external part numbers starting with LM3S, LM4S, and LM4F.									
23:16	PARTNO	RO	0xB1	<p>Part Number</p> <p>This field provides the part number of the device within the family. The reset value shown indicates the LM4F231H5QR microcontroller.</p>						

Bit/Field	Name	Type	Reset	Description														
15:13	PINCOUNT	RO	0x3	<p>Package Pin Count</p> <p>This field specifies the number of pins on the device package. The value is encoded as follows (all other encodings are reserved):</p> <table border="1"> <thead> <tr> <th>Value</th> <th>Description</th> </tr> </thead> <tbody> <tr> <td>0x0</td> <td>28-pin package</td> </tr> <tr> <td>0x1</td> <td>48-pin package</td> </tr> <tr> <td>0x2</td> <td>100-pin package</td> </tr> <tr> <td>0x3</td> <td>64-pin package</td> </tr> <tr> <td>0x4</td> <td>144-pin package</td> </tr> <tr> <td>0x5</td> <td>157-pin package</td> </tr> </tbody> </table>	Value	Description	0x0	28-pin package	0x1	48-pin package	0x2	100-pin package	0x3	64-pin package	0x4	144-pin package	0x5	157-pin package
Value	Description																	
0x0	28-pin package																	
0x1	48-pin package																	
0x2	100-pin package																	
0x3	64-pin package																	
0x4	144-pin package																	
0x5	157-pin package																	
12:8	reserved	RO	0	Software should not rely on the value of a reserved bit. To provide compatibility with future products, the value of a reserved bit should be preserved across a read-modify-write operation.														
7:5	TEMP	RO	0x1	<p>Temperature Range</p> <p>This field specifies the temperature rating of the device. The value is encoded as follows (all other encodings are reserved):</p> <table border="1"> <thead> <tr> <th>Value</th> <th>Description</th> </tr> </thead> <tbody> <tr> <td>0x0</td> <td>Commercial temperature range (0°C to 70°C)</td> </tr> <tr> <td>0x1</td> <td>Industrial temperature range (-40°C to 85°C)</td> </tr> <tr> <td>0x2</td> <td>Extended temperature range (-40°C to 105°C)</td> </tr> </tbody> </table>	Value	Description	0x0	Commercial temperature range (0°C to 70°C)	0x1	Industrial temperature range (-40°C to 85°C)	0x2	Extended temperature range (-40°C to 105°C)						
Value	Description																	
0x0	Commercial temperature range (0°C to 70°C)																	
0x1	Industrial temperature range (-40°C to 85°C)																	
0x2	Extended temperature range (-40°C to 105°C)																	
4:3	PKG	RO	0x1	<p>Package Type</p> <p>This field specifies the package type. The value is encoded as follows (all other encodings are reserved):</p> <table border="1"> <thead> <tr> <th>Value</th> <th>Description</th> </tr> </thead> <tbody> <tr> <td>0x0</td> <td>SOIC package</td> </tr> <tr> <td>0x1</td> <td>LQFP package</td> </tr> <tr> <td>0x2</td> <td>BGA package</td> </tr> </tbody> </table>	Value	Description	0x0	SOIC package	0x1	LQFP package	0x2	BGA package						
Value	Description																	
0x0	SOIC package																	
0x1	LQFP package																	
0x2	BGA package																	
2	ROHS	RO	0x1	<p>RoHS-Compliance</p> <p>This bit specifies whether the device is RoHS-compliant. A 1 indicates the part is RoHS-compliant.</p>														
1:0	QUAL	RO	-	<p>Qualification Status</p> <p>This field specifies the qualification status of the device. The value is encoded as follows (all other encodings are reserved):</p> <table border="1"> <thead> <tr> <th>Value</th> <th>Description</th> </tr> </thead> <tbody> <tr> <td>0x0</td> <td>Engineering Sample (unqualified)</td> </tr> <tr> <td>0x1</td> <td>Pilot Production (unqualified)</td> </tr> <tr> <td>0x2</td> <td>Fully Qualified</td> </tr> </tbody> </table>	Value	Description	0x0	Engineering Sample (unqualified)	0x1	Pilot Production (unqualified)	0x2	Fully Qualified						
Value	Description																	
0x0	Engineering Sample (unqualified)																	
0x1	Pilot Production (unqualified)																	
0x2	Fully Qualified																	

Register 3: Brown-Out Reset Control (PBORCTL), offset 0x030

This register is responsible for controlling reset conditions after initial power-on reset.

Brown-Out Reset Control (PBORCTL)

Base 0x400F.E000
 Offset 0x030
 Type R/W, reset 0x0000.0000

	31	30	29	28	27	26	25	24	23	22	21	20	19	18	17	16	
	reserved																
Type	RO	RO	RO	RO	RO	RO	RO	RO	RO	RO	RO	RO	RO	RO	RO	RO	
Reset	0	0	0	0	0	0	0	0	0	0	0	0	0	0	0	0	
	15	14	13	12	11	10	9	8	7	6	5	4	3	2	1	0	
	reserved															BORIOR	reserved
Type	RO	RO	RO	RO	RO	RO	RO	RO	RO	RO	RO	RO	RO	RO	RO	R/W	RO
Reset	0	0	0	0	0	0	0	0	0	0	0	0	0	0	0	0	0

Bit/Field	Name	Type	Reset	Description
31:2	reserved	RO	0	Software should not rely on the value of a reserved bit. To provide compatibility with future products, the value of a reserved bit should be preserved across a read-modify-write operation.
1	BORIOR	R/W	0	BOR Interrupt or Reset Value Description 0 A Brown Out Event causes an interrupt to be generated to the interrupt controller. 1 A Brown Out Event causes a reset of the microcontroller.
0	reserved	RO	0	Software should not rely on the value of a reserved bit. To provide compatibility with future products, the value of a reserved bit should be preserved across a read-modify-write operation.

Register 4: Raw Interrupt Status (RIS), offset 0x050

This register indicates the status for system control raw interrupts. An interrupt is sent to the interrupt controller if the corresponding bit in the **Interrupt Mask Control (IMC)** register is set. Writing a 1 to the corresponding bit in the **Masked Interrupt Status and Clear (MISC)** register clears an interrupt status bit.

Raw Interrupt Status (RIS)

Base 0x400F.E000

Offset 0x050

Type RO, reset 0x0000.0000

	31	30	29	28	27	26	25	24	23	22	21	20	19	18	17	16	
	reserved																
Type	RO	RO	RO	RO	RO	RO	RO	RO	RO	RO	RO	RO	RO	RO	RO	RO	
Reset	0	0	0	0	0	0	0	0	0	0	0	0	0	0	0	0	
	15	14	13	12	11	10	9	8	7	6	5	4	3	2	1	0	
	reserved							MOSCPUPRIS	USBPLLRLIS	PLLLRIS	reserved			MOFRIS	reserved	BORRIS	reserved
Type	RO	RO	RO	RO	RO	RO	RO	RO	RO	RO	RO	RO	RO	RO	RO	RO	
Reset	0	0	0	0	0	0	0	0	0	0	0	0	0	0	0	0	

Bit/Field	Name	Type	Reset	Description
31:9	reserved	RO	0x0000.00	Software should not rely on the value of a reserved bit. To provide compatibility with future products, the value of a reserved bit should be preserved across a read-modify-write operation.
8	MOSCPUPRIS	RO	0	<p>MOSC Power Up Raw Interrupt Status</p> <p>Value Description</p> <p>1 Sufficient time has passed for the MOSC to reach the expected frequency. The value for this power-up time is indicated by T_{MOSC_START}.</p> <p>0 Sufficient time has not passed for the MOSC to reach the expected frequency.</p> <p>This bit is cleared by writing a 1 to the MOSCPUPMIS bit in the MISC register.</p>
7	USBPLLRLIS	RO	0	<p>USB PLL Lock Raw Interrupt Status</p> <p>Value Description</p> <p>1 The USB PLL timer has reached T_{READY} indicating that sufficient time has passed for the USB PLL to lock.</p> <p>0 The USB PLL timer has not reached T_{READY}.</p> <p>This bit is cleared by writing a 1 to the USBPLLRLMIS bit in the MISC register.</p>
6	PLLLRIS	RO	0	<p>PLL Lock Raw Interrupt Status</p> <p>Value Description</p> <p>1 The PLL timer has reached T_{READY} indicating that sufficient time has passed for the PLL to lock.</p> <p>0 The PLL timer has not reached T_{READY}.</p> <p>This bit is cleared by writing a 1 to the PLLRLMIS bit in the MISC register.</p>

Bit/Field	Name	Type	Reset	Description
5:4	reserved	RO	0x0	Software should not rely on the value of a reserved bit. To provide compatibility with future products, the value of a reserved bit should be preserved across a read-modify-write operation.
3	MOFRIS	RO	0	<p>Main Oscillator Failure Raw Interrupt Status</p> <p>Value Description</p> <p>1 The MOSCIM bit in the MOSCCTL register is set and the main oscillator has failed.</p> <p>0 The main oscillator has not failed.</p> <p>This bit is cleared by writing a 1 to the MOFMIS bit in the MISC register.</p>
2	reserved	RO	0	Software should not rely on the value of a reserved bit. To provide compatibility with future products, the value of a reserved bit should be preserved across a read-modify-write operation.
1	BORRIS	RO	0	<p>Brown-Out Reset Raw Interrupt Status</p> <p>Value Description</p> <p>1 A brown-out condition is currently active.</p> <p>0 A brown-out condition is not currently active.</p> <p>Note the BORIOR bit in the PBORCTL register must be cleared to cause an interrupt due to a Brown Out Event.</p> <p>This bit is cleared by writing a 1 to the BORMIS bit in the MISC register.</p>
0	reserved	RO	0	Software should not rely on the value of a reserved bit. To provide compatibility with future products, the value of a reserved bit should be preserved across a read-modify-write operation.

Register 5: Interrupt Mask Control (IMC), offset 0x054

This register contains the mask bits for system control raw interrupts. A raw interrupt, indicated by a bit being set in the **Raw Interrupt Status (RIS)** register, is sent to the interrupt controller if the corresponding bit in this register is set.

Interrupt Mask Control (IMC)

Base 0x400F.E000
 Offset 0x054
 Type R/W, reset 0x0000.0000

	31	30	29	28	27	26	25	24	23	22	21	20	19	18	17	16
	reserved															
Type	RO	RO	RO	RO	RO	RO	RO	RO	RO	RO	RO	RO	RO	RO	RO	RO
Reset	0	0	0	0	0	0	0	0	0	0	0	0	0	0	0	0
	15	14	13	12	11	10	9	8	7	6	5	4	3	2	1	0
	reserved							MOSCPUPIM	USBPLLIM	PLLIM	reserved		MOFIM	reserved	BORIM	reserved
Type	RO	RO	RO	RO	RO	RO	RO	R/W	R/W	R/W	RO	RO	RO	RO	R/W	RO
Reset	0	0	0	0	0	0	0	0	0	0	0	0	0	0	0	0

Bit/Field	Name	Type	Reset	Description
31:9	reserved	RO	0x0000.00	Software should not rely on the value of a reserved bit. To provide compatibility with future products, the value of a reserved bit should be preserved across a read-modify-write operation.
8	MOSCPUPIM	R/W	0	MOSC Power Up Interrupt Mask Value Description 1 An interrupt is sent to the interrupt controller when the MOSCPUPRIS bit in the RIS register is set. 0 The MOSCPUPRIS interrupt is suppressed and not sent to the interrupt controller.
7	USBPLLIM	R/W	0	USB PLL Lock Interrupt Mask Value Description 1 An interrupt is sent to the interrupt controller when the USBPLLRRIS bit in the RIS register is set. 0 The USBPLLRRIS interrupt is suppressed and not sent to the interrupt controller.
6	PLLIM	R/W	0	PLL Lock Interrupt Mask Value Description 1 An interrupt is sent to the interrupt controller when the PLLRRIS bit in the RIS register is set. 0 The PLLRRIS interrupt is suppressed and not sent to the interrupt controller.
5:4	reserved	RO	0x0	Software should not rely on the value of a reserved bit. To provide compatibility with future products, the value of a reserved bit should be preserved across a read-modify-write operation.

Bit/Field	Name	Type	Reset	Description
3	MOFIM	RO	0	Main Oscillator Failure Interrupt Mask Value Description 1 An interrupt is sent to the interrupt controller when the MOFRIS bit in the RIS register is set. 0 The MOFRIS interrupt is suppressed and not sent to the interrupt controller.
2	reserved	RO	0	Software should not rely on the value of a reserved bit. To provide compatibility with future products, the value of a reserved bit should be preserved across a read-modify-write operation.
1	BORIM	R/W	0	Brown-Out Reset Interrupt Mask Value Description 1 An interrupt is sent to the interrupt controller when the BORRIS bit in the RIS register is set. 0 The BORRIS interrupt is suppressed and not sent to the interrupt controller.
0	reserved	RO	0	Software should not rely on the value of a reserved bit. To provide compatibility with future products, the value of a reserved bit should be preserved across a read-modify-write operation.

Register 6: Masked Interrupt Status and Clear (MISC), offset 0x058

On a read, this register gives the current masked status value of the corresponding interrupt in the **Raw Interrupt Status (RIS)** register. All of the bits are R/W1C, thus writing a 1 to a bit clears the corresponding raw interrupt bit in the **RIS** register (see page 241).

Masked Interrupt Status and Clear (MISC)

Base 0x400F.E000

Offset 0x058

Type R/W1C, reset 0x0000.0000

	31	30	29	28	27	26	25	24	23	22	21	20	19	18	17	16
	reserved															
Type	RO	RO	RO	RO	RO	RO	RO	RO	RO	RO	RO	RO	RO	RO	RO	RO
Reset	0	0	0	0	0	0	0	0	0	0	0	0	0	0	0	0
	15	14	13	12	11	10	9	8	7	6	5	4	3	2	1	0
	reserved							MOSCPUPMIS	USBPLLLMIS	PLLLMIS	reserved		MOFMIS	reserved	BORMIS	reserved
Type	RO	RO	RO	RO	RO	RO	RO	R/W1C	R/W1C	R/W1C	RO	RO	RO	RO	R/W1C	RO
Reset	0	0	0	0	0	0	0	0	0	0	0	0	0	0	0	0

Bit/Field	Name	Type	Reset	Description
31:9	reserved	RO	0x0000.00	Software should not rely on the value of a reserved bit. To provide compatibility with future products, the value of a reserved bit should be preserved across a read-modify-write operation.
8	MOSCPUPMIS	R/W1C	0	MOSC Power Up Masked Interrupt Status Value Description 1 When read, a 1 indicates that an unmasked interrupt was signaled because sufficient time has passed for the MOSC PLL to lock. Writing a 1 to this bit clears it and also the <code>MOSCPUPRIS</code> bit in the RIS register. 0 When read, a 0 indicates that sufficient time has not passed for the MOSC PLL to lock. A write of 0 has no effect on the state of this bit.
7	USBPLLLMIS	R/W1C	0	USB PLL Lock Masked Interrupt Status Value Description 1 When read, a 1 indicates that an unmasked interrupt was signaled because sufficient time has passed for the USB PLL to lock. Writing a 1 to this bit clears it and also the <code>USBPLLLRIS</code> bit in the RIS register. 0 When read, a 0 indicates that sufficient time has not passed for the USB PLL to lock. A write of 0 has no effect on the state of this bit.

Bit/Field	Name	Type	Reset	Description
6	PLLLMIS	R/W1C	0	<p>PLL Lock Masked Interrupt Status</p> <p>Value Description</p> <p>1 When read, a 1 indicates that an unmasked interrupt was signaled because sufficient time has passed for the PLL to lock. Writing a 1 to this bit clears it and also the <code>PLLLRIS</code> bit in the RIS register.</p> <p>0 When read, a 0 indicates that sufficient time has not passed for the PLL to lock. A write of 0 has no effect on the state of this bit.</p>
5:4	reserved	RO	0x0	Software should not rely on the value of a reserved bit. To provide compatibility with future products, the value of a reserved bit should be preserved across a read-modify-write operation.
3	MOFMIS	RO	0	<p>Main Oscillator Failure Masked Interrupt Status</p> <p>Value Description</p> <p>1 When read, a 1 indicates that an unmasked interrupt was signaled because the main oscillator failed. Writing a 1 to this bit clears it and also the <code>MOFRIS</code> bit in the RIS register.</p> <p>0 When read, a 0 indicates that the main oscillator has not failed. A write of 0 has no effect on the state of this bit.</p>
2	reserved	RO	0	Software should not rely on the value of a reserved bit. To provide compatibility with future products, the value of a reserved bit should be preserved across a read-modify-write operation.
1	BORMIS	R/W1C	0	<p>BOR Masked Interrupt Status</p> <p>Value Description</p> <p>1 When read, a 1 indicates that an unmasked interrupt was signaled because of a brown-out condition. Writing a 1 to this bit clears it and also the <code>BORRIS</code> bit in the RIS register.</p> <p>0 When read, a 0 indicates that a brown-out condition has not occurred. A write of 0 has no effect on the state of this bit.</p>
0	reserved	RO	0	Software should not rely on the value of a reserved bit. To provide compatibility with future products, the value of a reserved bit should be preserved across a read-modify-write operation.

Register 7: Reset Cause (RESC), offset 0x05C

This register is set with the reset cause after reset. The bits in this register are sticky and maintain their state across multiple reset sequences, except when an power-on reset is the cause, in which case, all bits other than `POR` in the **RESC** register are cleared.

Reset Cause (RESC)

Base 0x400F.E000

Offset 0x05C

Type R/W, reset -

	31	30	29	28	27	26	25	24	23	22	21	20	19	18	17	16
	reserved															MOSCFAIL
Type	RO	RO	RO	RO	RO	RO	RO	RO	RO	RO	RO	RO	RO	RO	RO	RO
Reset	0	0	0	0	0	0	0	0	0	0	0	0	0	0	0	0
	15	14	13	12	11	10	9	8	7	6	5	4	3	2	1	0
	reserved										WDT1	SW	WDT0	BOR	POR	EXT
Type	RO	RO	RO	RO	RO	RO	RO	RO	RO	RO	R/W	R/W	R/W	R/W	R/W	R/W
Reset	0	0	0	0	0	0	0	0	0	0	-	-	-	-	-	-

Bit/Field	Name	Type	Reset	Description
31:17	reserved	RO	0x000	Software should not rely on the value of a reserved bit. To provide compatibility with future products, the value of a reserved bit should be preserved across a read-modify-write operation.
16	MOSCFAIL	R/W	-	MOSC Failure Reset
				Value Description
				1 When read, this bit indicates that the MOSC circuit was enabled for clock validation and failed while the <code>MOSCIM</code> bit in the MOSCCTL register is clear, generating a reset event.
				0 When read, this bit indicates that a MOSC failure has not generated a reset since the previous power-on reset. Writing a 0 to this bit clears it.
15:6	reserved	RO	0x00	Software should not rely on the value of a reserved bit. To provide compatibility with future products, the value of a reserved bit should be preserved across a read-modify-write operation.
5	WDT1	R/W	-	Watchdog Timer 1 Reset
				Value Description
				1 When read, this bit indicates that Watchdog Timer 1 timed out and generated a reset.
				0 When read, this bit indicates that Watchdog Timer 1 has not generated a reset since the previous power-on reset. Writing a 0 to this bit clears it.

Bit/Field	Name	Type	Reset	Description
4	SW	R/W	-	<p>Software Reset</p> <p>Value Description</p> <p>1 When read, this bit indicates that a software reset has caused a reset event.</p> <p>0 When read, this bit indicates that a software reset has not generated a reset since the previous power-on reset. Writing a 0 to this bit clears it.</p>
3	WDT0	R/W	-	<p>Watchdog Timer 0 Reset</p> <p>Value Description</p> <p>1 When read, this bit indicates that Watchdog Timer 0 timed out and generated a reset.</p> <p>0 When read, this bit indicates that Watchdog Timer 0 has not generated a reset since the previous power-on reset. Writing a 0 to this bit clears it.</p>
2	BOR	R/W	-	<p>Brown-Out Reset</p> <p>Value Description</p> <p>1 When read, this bit indicates that a brown-out reset has caused a reset event.</p> <p>0 When read, this bit indicates that a brown-out reset has not generated a reset since the previous power-on reset. Writing a 0 to this bit clears it.</p>
1	POR	R/W	-	<p>Power-On Reset</p> <p>Value Description</p> <p>1 When read, this bit indicates that a power-on reset has caused a reset event.</p> <p>0 When read, this bit indicates that a power-on reset has not generated a reset. Writing a 0 to this bit clears it.</p>
0	EXT	R/W	-	<p>External Reset</p> <p>Value Description</p> <p>1 When read, this bit indicates that an external reset (\overline{RST} assertion) has caused a reset event.</p> <p>0 When read, this bit indicates that an external reset (\overline{RST} assertion) has not caused a reset event since the previous power-on reset. Writing a 0 to this bit clears it.</p>

Register 8: Run-Mode Clock Configuration (RCC), offset 0x060

The bits in this register configure the system clock and oscillators.

Important: Write the **RCC** register prior to writing the **RCC2** register. If a subsequent write to the **RCC** register is required, include another register access after writing the **RCC** register and before writing the **RCC2** register.

The **USEPWMDIV** and **PWMDIV** fields in the **PWM Peripheral Configuration (PWMP)** register should be used to control the PWM clock. To support legacy software, the **USEPWMDIV** and **PWMDIV** fields in this register are available. A write to these legacy fields also writes the corresponding fields in the **PWMP** register. If these fields are changed by writing to this register, they can be read back correctly with a read of this register. If software uses the **PWMP** register to configure the PWM clock, the PWM clock operates as specified, but the value of **USEPWMDIV** and **PWMDIV** fields in this register are not modified.

Run-Mode Clock Configuration (RCC)

Base 0x400F.E000
Offset 0x060
Type R/W, reset 0x078E.3D51

	31	30	29	28	27	26	25	24	23	22	21	20	19	18	17	16
	reserved				ACG	SYSDIV				USESYSDIV	reserved	USEPWMDIV	PWMDIV			reserved
Type	RO	RO	RO	RO	R/W	R/W	R/W	R/W	R/W	R/W	RO	R/W	R/W	R/W	R/W	RO
Reset	0	0	0	0	0	1	1	1	1	0	0	0	1	1	1	0
	15	14	13	12	11	10	9	8	7	6	5	4	3	2	1	0
	reserved		PWRDN	reserved	BYPASS	XTAL				OSCSRC		reserved		IOSCDIS	MOSCDIS	
Type	RO	RO	R/W	RO	R/W	R/W	R/W	R/W	R/W	R/W	R/W	R/W	RO	RO	R/W	R/W
Reset	0	0	1	1	1	1	0	1	0	1	0	1	0	0	0	1

Bit/Field	Name	Type	Reset	Description						
31:28	reserved	RO	0x0	Software should not rely on the value of a reserved bit. To provide compatibility with future products, the value of a reserved bit should be preserved across a read-modify-write operation.						
27	ACG	R/W	0	<p>Auto Clock Gating</p> <p>This bit specifies whether the system uses the Sleep-Mode Clock Gating Control (SCGCn) registers and Deep-Sleep-Mode Clock Gating Control (DCGCn) registers if the microcontroller enters a Sleep or Deep-Sleep mode (respectively).</p> <table border="1"> <thead> <tr> <th>Value</th> <th>Description</th> </tr> </thead> <tbody> <tr> <td>1</td> <td>The SCGCn or DCGCn registers are used to control the clocks distributed to the peripherals when the microcontroller is in a sleep mode. The SCGCn and DCGCn registers allow unused peripherals to consume less power when the microcontroller is in a sleep mode.</td> </tr> <tr> <td>0</td> <td>The Run-Mode Clock Gating Control (RCGCn) registers are used when the microcontroller enters a sleep mode.</td> </tr> </tbody> </table> <p>The RCGCn registers are always used to control the clocks in Run mode.</p>	Value	Description	1	The SCGCn or DCGCn registers are used to control the clocks distributed to the peripherals when the microcontroller is in a sleep mode. The SCGCn and DCGCn registers allow unused peripherals to consume less power when the microcontroller is in a sleep mode.	0	The Run-Mode Clock Gating Control (RCGCn) registers are used when the microcontroller enters a sleep mode.
Value	Description									
1	The SCGCn or DCGCn registers are used to control the clocks distributed to the peripherals when the microcontroller is in a sleep mode. The SCGCn and DCGCn registers allow unused peripherals to consume less power when the microcontroller is in a sleep mode.									
0	The Run-Mode Clock Gating Control (RCGCn) registers are used when the microcontroller enters a sleep mode.									

Bit/Field	Name	Type	Reset	Description
26:23	SYSDIV	R/W	0xF	<p>System Clock Divisor</p> <p>Specifies which divisor is used to generate the system clock from either the PLL output or the oscillator source (depending on how the <code>BYPASS</code> bit in this register is configured). See Table 5-4 on page 223 for bit encodings.</p> <p>If the <code>SYSDIV</code> value is less than <code>MINSYSDIV</code> (see page 434), and the PLL is being used, then the <code>MINSYSDIV</code> value is used as the divisor.</p> <p>If the PLL is not being used, the <code>SYSDIV</code> value can be less than <code>MINSYSDIV</code>.</p>
22	USESYSYSDIV	R/W	0	<p>Enable System Clock Divider</p> <p>Value Description</p> <p>1 The system clock divider is the source for the system clock. The system clock divider is forced to be used when the PLL is selected as the source.</p> <p>If the <code>USERCC2</code> bit in the <code>RCC2</code> register is set, then the <code>SYSDIV2</code> field in the <code>RCC2</code> register is used as the system clock divider rather than the <code>SYSDIV</code> field in this register.</p> <p>0 The system clock is used undivided.</p>
21	reserved	RO	0	Software should not rely on the value of a reserved bit. To provide compatibility with future products, the value of a reserved bit should be preserved across a read-modify-write operation.
20	USEPWMDIV	R/W	0	<p>Enable PWM Clock Divisor</p> <p>Value Description</p> <p>1 The PWM clock divider is the source for the PWM clock.</p> <p>0 The system clock is the source for the PWM clock.</p> <p>Note that when the PWM divisor is used, it is applied to the clock for both PWM modules.</p>
19:17	PWMDIV	R/W	0x7	<p>PWM Unit Clock Divisor</p> <p>This field specifies the binary divisor used to predivide the system clock down for use as the timing reference for the PWM module. The rising edge of this clock is synchronous with the system clock.</p> <p>Value Divisor</p> <p>0x0 /2</p> <p>0x1 /4</p> <p>0x2 /8</p> <p>0x3 /16</p> <p>0x4 /32</p> <p>0x5 /64</p> <p>0x6 /64</p> <p>0x7 /64 (default)</p>

Bit/Field	Name	Type	Reset	Description
16:14	reserved	RO	0x0	Software should not rely on the value of a reserved bit. To provide compatibility with future products, the value of a reserved bit should be preserved across a read-modify-write operation.
13	PWRDN	R/W	1	<p>PLL Power Down</p> <p>Value Description</p> <p>1 The PLL is powered down. Care must be taken to ensure that another clock source is functioning and that the <code>BYPASS</code> bit is set before setting this bit.</p> <p>0 The PLL is operating normally.</p>
12	reserved	RO	1	Software should not rely on the value of a reserved bit. To provide compatibility with future products, the value of a reserved bit should be preserved across a read-modify-write operation.
11	BYPASS	R/W	1	<p>PLL Bypass</p> <p>Value Description</p> <p>1 The system clock is derived from the <code>OSC</code> source and divided by the divisor specified by <code>SYSDIV</code>.</p> <p>0 The system clock is the PLL output clock divided by the divisor specified by <code>SYSDIV</code>.</p> <p>See Table 5-4 on page 223 for programming guidelines.</p> <p>Note: The ADC must be clocked from the PLL or directly from a 16-MHz clock source to operate properly.</p>

Bit/Field	Name	Type	Reset	Description																																																																					
10:6	XTAL	R/W	0x15	<p>Crystal Value</p> <p>This field specifies the crystal value attached to the main oscillator. The encoding for this field is provided below.</p> <p>Frequencies that may be used with the USB interface are indicated in the table. To function within the clocking requirements of the USB specification, a crystal of 5, 6, 8, 10, 12, or 16 MHz must be used.</p> <table border="1"> <thead> <tr> <th>Value</th> <th>Crystal Frequency (MHz) Not Using the PLL</th> <th>Crystal Frequency (MHz) Using the PLL</th> </tr> </thead> <tbody> <tr> <td>0x00-0x5</td> <td></td> <td>reserved</td> </tr> <tr> <td>0x06</td> <td>4 MHz</td> <td>reserved</td> </tr> <tr> <td>0x07</td> <td>4.096 MHz</td> <td>reserved</td> </tr> <tr> <td>0x08</td> <td>4.9152 MHz</td> <td>reserved</td> </tr> <tr> <td>0x09</td> <td></td> <td>5 MHz (USB)</td> </tr> <tr> <td>0x0A</td> <td></td> <td>5.12 MHz</td> </tr> <tr> <td>0x0B</td> <td></td> <td>6 MHz (USB)</td> </tr> <tr> <td>0x0C</td> <td></td> <td>6.144 MHz</td> </tr> <tr> <td>0x0D</td> <td></td> <td>7.3728 MHz</td> </tr> <tr> <td>0x0E</td> <td></td> <td>8 MHz (USB)</td> </tr> <tr> <td>0x0F</td> <td></td> <td>8.192 MHz</td> </tr> <tr> <td>0x10</td> <td></td> <td>10.0 MHz (USB)</td> </tr> <tr> <td>0x11</td> <td></td> <td>12.0 MHz (USB)</td> </tr> <tr> <td>0x12</td> <td></td> <td>12.288 MHz</td> </tr> <tr> <td>0x13</td> <td></td> <td>13.56 MHz</td> </tr> <tr> <td>0x14</td> <td></td> <td>14.31818 MHz</td> </tr> <tr> <td>0x15</td> <td></td> <td>16.0 MHz (reset value)(USB)</td> </tr> <tr> <td>0x16</td> <td></td> <td>16.384 MHz</td> </tr> <tr> <td>0x17</td> <td></td> <td>18.0 MHz (USB)</td> </tr> <tr> <td>0x18</td> <td></td> <td>20.0 MHz (USB)</td> </tr> <tr> <td>0x19</td> <td></td> <td>24.0 MHz (USB)</td> </tr> <tr> <td>0x1A</td> <td></td> <td>25.0 MHz (USB)</td> </tr> </tbody> </table>	Value	Crystal Frequency (MHz) Not Using the PLL	Crystal Frequency (MHz) Using the PLL	0x00-0x5		reserved	0x06	4 MHz	reserved	0x07	4.096 MHz	reserved	0x08	4.9152 MHz	reserved	0x09		5 MHz (USB)	0x0A		5.12 MHz	0x0B		6 MHz (USB)	0x0C		6.144 MHz	0x0D		7.3728 MHz	0x0E		8 MHz (USB)	0x0F		8.192 MHz	0x10		10.0 MHz (USB)	0x11		12.0 MHz (USB)	0x12		12.288 MHz	0x13		13.56 MHz	0x14		14.31818 MHz	0x15		16.0 MHz (reset value)(USB)	0x16		16.384 MHz	0x17		18.0 MHz (USB)	0x18		20.0 MHz (USB)	0x19		24.0 MHz (USB)	0x1A		25.0 MHz (USB)
Value	Crystal Frequency (MHz) Not Using the PLL	Crystal Frequency (MHz) Using the PLL																																																																							
0x00-0x5		reserved																																																																							
0x06	4 MHz	reserved																																																																							
0x07	4.096 MHz	reserved																																																																							
0x08	4.9152 MHz	reserved																																																																							
0x09		5 MHz (USB)																																																																							
0x0A		5.12 MHz																																																																							
0x0B		6 MHz (USB)																																																																							
0x0C		6.144 MHz																																																																							
0x0D		7.3728 MHz																																																																							
0x0E		8 MHz (USB)																																																																							
0x0F		8.192 MHz																																																																							
0x10		10.0 MHz (USB)																																																																							
0x11		12.0 MHz (USB)																																																																							
0x12		12.288 MHz																																																																							
0x13		13.56 MHz																																																																							
0x14		14.31818 MHz																																																																							
0x15		16.0 MHz (reset value)(USB)																																																																							
0x16		16.384 MHz																																																																							
0x17		18.0 MHz (USB)																																																																							
0x18		20.0 MHz (USB)																																																																							
0x19		24.0 MHz (USB)																																																																							
0x1A		25.0 MHz (USB)																																																																							

Bit/Field	Name	Type	Reset	Description										
5:4	OSCSRC	R/W	0x1	<p>Oscillator Source</p> <p>Selects the input source for the OSC. The values are:</p> <table border="1"> <thead> <tr> <th>Value</th> <th>Input Source</th> </tr> </thead> <tbody> <tr> <td>0x0</td> <td>MOSC Main oscillator</td> </tr> <tr> <td>0x1</td> <td>PIOSC Precision internal oscillator (default)</td> </tr> <tr> <td>0x2</td> <td>PIOSC/4 Precision internal oscillator / 4</td> </tr> <tr> <td>0x3</td> <td>30 kHz 30-kHz internal oscillator</td> </tr> </tbody> </table> <p>For additional oscillator sources, see the RCC2 register.</p>	Value	Input Source	0x0	MOSC Main oscillator	0x1	PIOSC Precision internal oscillator (default)	0x2	PIOSC/4 Precision internal oscillator / 4	0x3	30 kHz 30-kHz internal oscillator
Value	Input Source													
0x0	MOSC Main oscillator													
0x1	PIOSC Precision internal oscillator (default)													
0x2	PIOSC/4 Precision internal oscillator / 4													
0x3	30 kHz 30-kHz internal oscillator													
3:2	reserved	RO	0x0	Software should not rely on the value of a reserved bit. To provide compatibility with future products, the value of a reserved bit should be preserved across a read-modify-write operation.										
1	IOSCDIS	R/W	0	<p>Precision Internal Oscillator Disable</p> <table border="1"> <thead> <tr> <th>Value</th> <th>Description</th> </tr> </thead> <tbody> <tr> <td>1</td> <td>The precision internal oscillator (PIOSC) is disabled.</td> </tr> <tr> <td>0</td> <td>The precision internal oscillator is enabled.</td> </tr> </tbody> </table>	Value	Description	1	The precision internal oscillator (PIOSC) is disabled.	0	The precision internal oscillator is enabled.				
Value	Description													
1	The precision internal oscillator (PIOSC) is disabled.													
0	The precision internal oscillator is enabled.													
0	MOSCDIS	R/W	1	<p>Main Oscillator Disable</p> <table border="1"> <thead> <tr> <th>Value</th> <th>Description</th> </tr> </thead> <tbody> <tr> <td>1</td> <td>The main oscillator is disabled (default).</td> </tr> <tr> <td>0</td> <td>The main oscillator is enabled.</td> </tr> </tbody> </table>	Value	Description	1	The main oscillator is disabled (default).	0	The main oscillator is enabled.				
Value	Description													
1	The main oscillator is disabled (default).													
0	The main oscillator is enabled.													

Register 9: GPIO High-Performance Bus Control (GPIOHBCTL), offset 0x06C

This register controls which internal bus is used to access each GPIO port. When a bit is clear, the corresponding GPIO port is accessed across the legacy Advanced Peripheral Bus (APB) bus and through the APB memory aperture. When a bit is set, the corresponding port is accessed across the Advanced High-Performance Bus (AHB) bus and through the AHB memory aperture. Each GPIO port can be individually configured to use AHB or APB, but may be accessed only through one aperture. The AHB bus provides better back-to-back access performance than the APB bus. The address aperture in the memory map changes for the ports that are enabled for AHB access (see Table 9-6 on page 632).

Important: Ports K-N and P-Q are only available on the AHB bus, and therefore the corresponding bits reset to 1. If one of these bits is cleared, the corresponding port is disabled. If any of these ports is in use, read-modify-write operations should be used to change the value of this register so that these ports remain enabled.

GPIO High-Performance Bus Control (GPIOHBCTL)

Base 0x400F.E000
 Offset 0x06C
 Type R/W, reset 0x0000.7E00

	31	30	29	28	27	26	25	24	23	22	21	20	19	18	17	16	
	reserved																
Type	RO	RO	RO	RO	RO	RO	RO	RO	RO	RO	RO	RO	RO	RO	RO	RO	
Reset	0	0	0	0	0	0	0	0	0	0	0	0	0	0	0	0	
	15	14	13	12	11	10	9	8	7	6	5	4	3	2	1	0	
	reserved										PORTG	PORTF	PORTE	PORTD	PORTC	PORTB	PORTA
Type	RO	RO	RO	RO	RO	RO	RO	RO	RO	RO	R/W	R/W	R/W	R/W	R/W	R/W	
Reset	0	0	0	0	0	0	0	0	0	0	0	0	0	0	0	0	

Bit/Field	Name	Type	Reset	Description
31:7	reserved	RO	0x0000.0	Software should not rely on the value of a reserved bit. To provide compatibility with future products, the value of a reserved bit should be preserved across a read-modify-write operation.
6	PORTG	R/W	0	Port G Advanced High-Performance Bus This bit defines the memory aperture for Port G. Value Description 1 Advanced High-Performance Bus (AHB) 0 Advanced Peripheral Bus (APB). This bus is the legacy bus.
5	PORTF	R/W	0	Port F Advanced High-Performance Bus This bit defines the memory aperture for Port F. Value Description 1 Advanced High-Performance Bus (AHB) 0 Advanced Peripheral Bus (APB). This bus is the legacy bus.

Bit/Field	Name	Type	Reset	Description
4	PORTE	R/W	0	Port E Advanced High-Performance Bus This bit defines the memory aperture for Port E. Value Description 1 Advanced High-Performance Bus (AHB) 0 Advanced Peripheral Bus (APB). This bus is the legacy bus.
3	PORTD	R/W	0	Port D Advanced High-Performance Bus This bit defines the memory aperture for Port D. Value Description 1 Advanced High-Performance Bus (AHB) 0 Advanced Peripheral Bus (APB). This bus is the legacy bus.
2	PORTC	R/W	0	Port C Advanced High-Performance Bus This bit defines the memory aperture for Port C. Value Description 1 Advanced High-Performance Bus (AHB) 0 Advanced Peripheral Bus (APB). This bus is the legacy bus.
1	PORTB	R/W	0	Port B Advanced High-Performance Bus This bit defines the memory aperture for Port B. Value Description 1 Advanced High-Performance Bus (AHB) 0 Advanced Peripheral Bus (APB). This bus is the legacy bus.
0	PORTA	R/W	0	Port A Advanced High-Performance Bus This bit defines the memory aperture for Port A. Value Description 1 Advanced High-Performance Bus (AHB) 0 Advanced Peripheral Bus (APB). This bus is the legacy bus.

Register 10: Run-Mode Clock Configuration 2 (RCC2), offset 0x070

This register overrides the **RCC** equivalent register fields, as shown in Table 5-8, when the `USERCC2` bit is set, allowing the extended capabilities of the **RCC2** register to be used while also providing a means to be backward-compatible to previous parts. Each **RCC2** field that supersedes an **RCC** field is located at the same LSB bit position; however, some **RCC2** fields are larger than the corresponding **RCC** field.

Table 5-8. RCC2 Fields that Override RCC Fields

RCC2 Field...	Overrides RCC Field
<code>SYSDIV2</code> , bits[28:23]	<code>SYSDIV</code> , bits[26:23]
<code>PWRDN2</code> , bit[13]	<code>PWRDN</code> , bit[13]
<code>BYPASS2</code> , bit[11]	<code>BYPASS</code> , bit[11]
<code>OSCSRC2</code> , bits[6:4]	<code>OSCSRC</code> , bits[5:4]

Important: Write the **RCC** register prior to writing the **RCC2** register. If a subsequent write to the **RCC** register is required, include another register access after writing the **RCC** register and before writing the **RCC2** register.

Run-Mode Clock Configuration 2 (RCC2)

Base 0x400F.E000
 Offset 0x070
 Type R/W, reset 0x07C0.6810

	31	30	29	28	27	26	25	24	23	22	21	20	19	18	17	16
	USERCC2	DIV400	reserved	SYSDIV2						SYSDIV2LSB	reserved					
Type	R/W	R/W	RO	R/W	R/W	R/W	R/W	R/W	R/W	R/W	RO	RO	RO	RO	RO	RO
Reset	0	0	0	0	0	1	1	1	1	1	0	0	0	0	0	0
	15	14	13	12	11	10	9	8	7	6	5	4	3	2	1	0
	reserved	USBPWRDN	PWRDN2	reserved	BYPASS2	reserved				OSCSRC2			reserved			
Type	RO	R/W	R/W	RO	R/W	RO	RO	RO	RO	R/W	R/W	R/W	RO	RO	RO	RO
Reset	0	1	1	0	1	0	0	0	0	0	0	1	0	0	0	0

Bit/Field	Name	Type	Reset	Description
31	USERCC2	R/W	0	Use RCC2
				Value Description
				1 The RCC2 register fields override the RCC register fields.
				0 The RCC register fields are used, and the fields in RCC2 are ignored.
30	DIV400	R/W	0	Divide PLL as 400 MHz vs. 200 MHz
				This bit, along with the <code>SYSDIV2LSB</code> bit, allows additional frequency choices.
				Value Description
				1 Append the <code>SYSDIV2LSB</code> bit to the <code>SYSDIV2</code> field to create a 7 bit divisor using the 400 MHz PLL output, see Table 5-6 on page 224.
				0 Use <code>SYSDIV2</code> as is and apply to 200 MHz predivided PLL output. See Table 5-5 on page 223 for programming guidelines.

Bit/Field	Name	Type	Reset	Description
29	reserved	RO	0x0	Software should not rely on the value of a reserved bit. To provide compatibility with future products, the value of a reserved bit should be preserved across a read-modify-write operation.
28:23	SYSDIV2	R/W	0x0F	System Clock Divisor 2 Specifies which divisor is used to generate the system clock from either the PLL output or the oscillator source (depending on how the <code>BYPASS2</code> bit is configured). <code>SYSDIV2</code> is used for the divisor when both the <code>USESYSCLK</code> bit in the <code>RCC</code> register and the <code>USERCC2</code> bit in this register are set. See Table 5-5 on page 223 for programming guidelines.
22	SYSDIV2LSB	R/W	1	Additional LSB for <code>SYSDIV2</code> When <code>DIV400</code> is set, this bit becomes the LSB of <code>SYSDIV2</code> . If <code>DIV400</code> is clear, this bit is not used. See Table 5-5 on page 223 for programming guidelines. This bit can only be set or cleared when <code>DIV400</code> is set.
21:15	reserved	RO	0x0	Software should not rely on the value of a reserved bit. To provide compatibility with future products, the value of a reserved bit should be preserved across a read-modify-write operation.
14	USBPWRDN	R/W	1	Power-Down USB PLL Value Description 1 The USB PLL is powered down. 0 The USB PLL operates normally.
13	PWRDN2	R/W	1	Power-Down PLL 2 Value Description 1 The PLL is powered down. 0 The PLL operates normally.
12	reserved	RO	0	Software should not rely on the value of a reserved bit. To provide compatibility with future products, the value of a reserved bit should be preserved across a read-modify-write operation.
11	BYPASS2	R/W	1	PLL Bypass 2 Value Description 1 The system clock is derived from the OSC source and divided by the divisor specified by <code>SYSDIV2</code> . 0 The system clock is the PLL output clock divided by the divisor specified by <code>SYSDIV2</code> . See Table 5-5 on page 223 for programming guidelines. Note: The ADC must be clocked from the PLL or directly from a 16-MHz clock source to operate properly.
10:7	reserved	RO	0x0	Software should not rely on the value of a reserved bit. To provide compatibility with future products, the value of a reserved bit should be preserved across a read-modify-write operation.

Bit/Field	Name	Type	Reset	Description
6:4	OSCSRC2	R/W	0x1	Oscillator Source 2 Selects the input source for the OSC. The values are: Value Description 0x0 MOSC Main oscillator 0x1 PIOSC Precision internal oscillator 0x2 PIOSC/4 Precision internal oscillator / 4 0x3 30 kHz 30-kHz internal oscillator 0x4-0x7 Reserved
3:0	reserved	RO	0x0	Software should not rely on the value of a reserved bit. To provide compatibility with future products, the value of a reserved bit should be preserved across a read-modify-write operation.

Register 11: Main Oscillator Control (MOSCCTL), offset 0x07C

This register provides control over the features of the main oscillator, including the ability to enable the MOSC clock verification circuit, what action to take when the MOSC fails, and whether or not a crystal is connected. When enabled, this circuit monitors the frequency of the MOSC to verify that the oscillator is operating within specified limits. If the clock goes invalid after being enabled, the microcontroller issues a power-on reset and reboots to the NMI handler or generates an interrupt.

Main Oscillator Control (MOSCCTL)

Base 0x400F.E000
Offset 0x07C
Type R/W, reset 0x0000.0000

	31	30	29	28	27	26	25	24	23	22	21	20	19	18	17	16
	reserved															
Type	RO	RO	RO	RO	RO	RO	RO	RO	RO	RO	RO	RO	RO	RO	RO	RO
Reset	0	0	0	0	0	0	0	0	0	0	0	0	0	0	0	0
	15	14	13	12	11	10	9	8	7	6	5	4	3	2	1	0
	reserved													NOXTAL	MOSCIM	CVAL
Type	RO	RO	RO	RO	RO	RO	RO	RO	RO	RO	RO	RO	RO	R/W	R/W	R/W
Reset	0	0	0	0	0	0	0	0	0	0	0	0	0	0	0	0

Bit/Field	Name	Type	Reset	Description
31:3	reserved	RO	0x0000.000	Software should not rely on the value of a reserved bit. To provide compatibility with future products, the value of a reserved bit should be preserved across a read-modify-write operation.
2	NOXTAL	R/W	0	No Crystal Connected Value Description 1 This bit should be set when a crystal or external oscillator is not connected to the OSC0 and OSC1 inputs to reduce power consumption. 0 This bit should be cleared when a crystal or oscillator is connected to the OSC0 and OSC1 inputs, regardless of whether or not the MOSC is used or powered down.
1	MOSCIM	R/W	0	MOSC Failure Action Value Description 1 If the MOSC fails, an interrupt is generated as indicated by the MOPRIS bit in the RIS register.. 0 If the MOSC fails, a MOSC failure reset is generated and reboots to the NMI handler. Regardless of the action taken, if the MOSC fails, the oscillator source is switched to the PIOSC automatically.
0	CVAL	R/W	0	Clock Validation for MOSC Value Description 1 The MOSC monitor circuit is enabled. 0 The MOSC monitor circuit is disabled.

Register 12: Deep Sleep Clock Configuration (DSLPCCLKCFG), offset 0x144

This register provides configuration information for the hardware control of Deep Sleep Mode.

Deep Sleep Clock Configuration (DSLPCCLKCFG)

Base 0x400F.E000
 Offset 0x144
 Type R/W, reset 0x0780.0000

	31	30	29	28	27	26	25	24	23	22	21	20	19	18	17	16
	reserved			DSDIVORIDE						reserved						
Type	RO	RO	RO	R/W	R/W	R/W	R/W	R/W	R/W	RO	RO	RO	RO	RO	RO	RO
Reset	0	0	0	0	0	1	1	1	1	0	0	0	0	0	0	0
	15	14	13	12	11	10	9	8	7	6	5	4	3	2	1	0
	reserved						DSOSCSRC					reserved				
Type	RO	RO	RO	RO	RO	RO	RO	RO	RO	R/W	R/W	R/W	RO	RO	RO	RO
Reset	0	0	0	0	0	0	0	0	0	0	0	0	0	0	0	0

Bit/Field	Name	Type	Reset	Description														
31:29	reserved	RO	0x0	Software should not rely on the value of a reserved bit. To provide compatibility with future products, the value of a reserved bit should be preserved across a read-modify-write operation.														
28:23	DSDIVORIDE	R/W	0x0F	<p>Divider Field Override</p> <p>If Deep-Sleep mode is enabled when the PLL is running, the PLL is disabled. This 6-bit field contains a system divider field that overrides the <code>SYSDIV</code> field in the <code>RCC</code> register or the <code>SYSDIV2</code> field in the <code>RCC2</code> register during Deep Sleep. This divider is applied to the source selected by the <code>DSOSCSRC</code> field.</p> <table border="1"> <thead> <tr> <th>Value</th> <th>Description</th> </tr> </thead> <tbody> <tr> <td>0x0</td> <td>/1</td> </tr> <tr> <td>0x1</td> <td>/2</td> </tr> <tr> <td>0x2</td> <td>/3</td> </tr> <tr> <td>0x3</td> <td>/4</td> </tr> <tr> <td>...</td> <td>...</td> </tr> <tr> <td>0x3F</td> <td>/64</td> </tr> </tbody> </table>	Value	Description	0x0	/1	0x1	/2	0x2	/3	0x3	/4	0x3F	/64
Value	Description																	
0x0	/1																	
0x1	/2																	
0x2	/3																	
0x3	/4																	
...	...																	
0x3F	/64																	
22:7	reserved	RO	0x000	Software should not rely on the value of a reserved bit. To provide compatibility with future products, the value of a reserved bit should be preserved across a read-modify-write operation.														

Bit/Field	Name	Type	Reset	Description												
6:4	DSOSCSRC	R/W	0x0	<p>Clock Source</p> <p>Specifies the clock source during Deep-Sleep mode.</p> <table border="1"> <thead> <tr> <th>Value</th> <th>Description</th> </tr> </thead> <tbody> <tr> <td>0x0</td> <td> <p>MOSC</p> <p>Use the main oscillator as the source.</p> <p>Note: If the PIOSC is being used as the clock reference for the PLL, the PIOSC is the clock source instead of MOSC in Deep-Sleep mode.</p> </td> </tr> <tr> <td>0x1</td> <td> <p>PIOSC</p> <p>Use the precision internal 16-MHz oscillator as the source.</p> </td> </tr> <tr> <td>0x2</td> <td>Reserved</td> </tr> <tr> <td>0x3</td> <td> <p>30 kHz</p> <p>Use the 30-kHz internal oscillator as the source.</p> </td> </tr> <tr> <td>0x4-0x7</td> <td>Reserved</td> </tr> </tbody> </table>	Value	Description	0x0	<p>MOSC</p> <p>Use the main oscillator as the source.</p> <p>Note: If the PIOSC is being used as the clock reference for the PLL, the PIOSC is the clock source instead of MOSC in Deep-Sleep mode.</p>	0x1	<p>PIOSC</p> <p>Use the precision internal 16-MHz oscillator as the source.</p>	0x2	Reserved	0x3	<p>30 kHz</p> <p>Use the 30-kHz internal oscillator as the source.</p>	0x4-0x7	Reserved
Value	Description															
0x0	<p>MOSC</p> <p>Use the main oscillator as the source.</p> <p>Note: If the PIOSC is being used as the clock reference for the PLL, the PIOSC is the clock source instead of MOSC in Deep-Sleep mode.</p>															
0x1	<p>PIOSC</p> <p>Use the precision internal 16-MHz oscillator as the source.</p>															
0x2	Reserved															
0x3	<p>30 kHz</p> <p>Use the 30-kHz internal oscillator as the source.</p>															
0x4-0x7	Reserved															
3:0	reserved	RO	0x0	Software should not rely on the value of a reserved bit. To provide compatibility with future products, the value of a reserved bit should be preserved across a read-modify-write operation.												

Register 13: System Properties (SYSPROP), offset 0x14C

This register provides information on whether certain System Control properties are present on the microcontroller.

System Properties (SYSPROP)

Base 0x400F.E000
 Offset 0x14C
 Type RO, reset 0x0000.1D31

	31	30	29	28	27	26	25	24	23	22	21	20	19	18	17	16
	reserved															
Type	RO	RO	RO	RO	RO	RO	RO	RO	RO	RO	RO	RO	RO	RO	RO	RO
Reset	0	0	0	0	0	0	0	0	0	0	0	0	0	0	0	0
	15	14	13	12	11	10	9	8	7	6	5	4	3	2	1	0
	reserved															FPU
Type	RO	RO	RO	RO	RO	RO	RO	RO	RO	RO	RO	RO	RO	RO	RO	RO
Reset	0	0	0	1	1	1	0	1	0	0	1	1	0	0	0	1

Bit/Field	Name	Type	Reset	Description	
31:1	reserved	RO	0xE98	Software should not rely on the value of a reserved bit. To provide compatibility with future products, the value of a reserved bit should be preserved across a read-modify-write operation.	
0	FPU	RO	0x1	FPU Present This bit indicates if the FPU is present in the Cortex-M4 core.	
Value Description					
	0	FPU is not present.			
	1	FPU is present.			

Register 14: Precision Internal Oscillator Calibration (PIOSCCAL), offset 0x150

This register provides the ability to update or recalibrate the precision internal oscillator.

Precision Internal Oscillator Calibration (PIOSCCAL)

Base 0x400F.E000

Offset 0x150

Type R/W, reset 0x0000.0000

	31	30	29	28	27	26	25	24	23	22	21	20	19	18	17	16
	UTEN	reserved														
Type	R/W	RO	RO	RO	RO	RO	RO	RO	RO	RO	RO	RO	RO	RO	RO	RO
Reset	0	0	0	0	0	0	0	0	0	0	0	0	0	0	0	0
	15	14	13	12	11	10	9	8	7	6	5	4	3	2	1	0
	reserved							UPDATE	reserved	UT						
Type	RO	RO	RO	RO	RO	RO	RO	R/W	RO	R/W	R/W	R/W	R/W	R/W	R/W	R/W
Reset	0	0	0	0	0	0	0	0	0	0	0	0	0	0	0	0

Bit/Field	Name	Type	Reset	Description
31	UTEN	R/W	0	Use User Trim Value Value Description 1 The trim value in bits[6:0] of this register are used for any update trim operation. 0 The factory calibration value is used for an update trim operation.
30:9	reserved	RO	0x0000	Software should not rely on the value of a reserved bit. To provide compatibility with future products, the value of a reserved bit should be preserved across a read-modify-write operation.
8	UPDATE	R/W	0	Update Trim Value Description 1 Updates the PIOSC trim value with the UT bit. Used with UTEN. 0 No action. This bit is auto-cleared after the update.
7	reserved	RO	0	Software should not rely on the value of a reserved bit. To provide compatibility with future products, the value of a reserved bit should be preserved across a read-modify-write operation.
6:0	UT	R/W	0x0	User Trim Value User trim value that can be loaded into the PIOSC. Refer to "Main PLL Frequency Configuration" on page 225 for more information on calibrating the PIOSC.

Register 15: PLL Frequency 0 (PLLREQ0), offset 0x160

This register always contains the current M value presented to the system PLL.

The PLL frequency can be calculated using the following equation:

$$\text{PLL frequency} = (\text{XTAL frequency} * \text{MDIV}) / ((Q + 1) * (N + 1))$$

where

$$\text{MDIV} = \text{MINT} + (\text{MFRAC} / 1024)$$

The Q and N values are shown in the **PLLREQ1** register. Table 24-10 on page 1329 shows the M, Q, and N values as well as the resulting PLL frequency for the various XTAL configurations.

PLL Frequency 0 (PLLREQ0)

Base 0x400F.E000
 Offset 0x160
 Type RO, reset 0x0000.0032

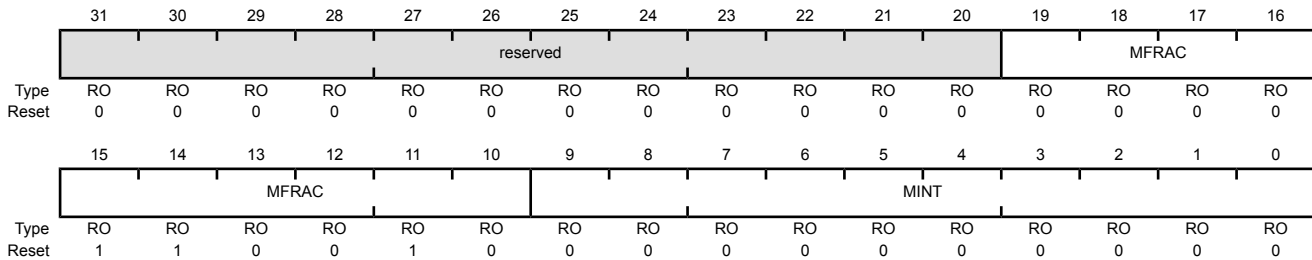

Bit/Field	Name	Type	Reset	Description
31:20	reserved	RO	0x000	Software should not rely on the value of a reserved bit. To provide compatibility with future products, the value of a reserved bit should be preserved across a read-modify-write operation.
19:10	MFRAC	RO	0x32	PLL M Fractional Value This field contains the integer value of the PLL M value.
9:0	MINT	RO	0x00	PLL M Integer Value This field contains the integer value of the PLL M value.

Register 16: PLL Frequency 1 (PLLREQ1), offset 0x164

This register always contains the current Q and N values presented to the system PLL.

The M value is shown in the **PLLREQ0** register. Table 24-10 on page 1329 shows the M, Q, and N values as well as the resulting PLL frequency for the various XTAL configurations.

PLL Frequency 1 (PLLREQ1)

Base 0x400F.E000

Offset 0x164

Type RO, reset 0x0000.0001

	31	30	29	28	27	26	25	24	23	22	21	20	19	18	17	16
	reserved															
Type	RO	RO	RO	RO	RO	RO	RO	RO	RO	RO	RO	RO	RO	RO	RO	RO
Reset	0	0	0	0	0	0	0	0	0	0	0	0	0	0	0	0
	15	14	13	12	11	10	9	8	7	6	5	4	3	2	1	0
	reserved			Q					reserved			N				
Type	RO	RO	RO	RO	RO	RO	RO	RO	RO	RO	RO	RO	RO	RO	RO	RO
Reset	0	0	0	0	0	0	0	0	0	0	0	0	0	0	0	1

Bit/Field	Name	Type	Reset	Description
31:13	reserved	RO	0x0000.0	Software should not rely on the value of a reserved bit. To provide compatibility with future products, the value of a reserved bit should be preserved across a read-modify-write operation.
12:8	Q	RO	0x0	PLL Q Value This field contains the PLL Q value.
7:5	reserved	RO	0x0	Software should not rely on the value of a reserved bit. To provide compatibility with future products, the value of a reserved bit should be preserved across a read-modify-write operation.
4:0	N	RO	0x1	PLL N Value This field contains the PLL N value.

Register 17: PLL Status (PLLSTAT), offset 0x168

This register shows the direct status of the PLL lock.

PLL Status (PLLSTAT)

Base 0x400F.E000

Offset 0x168

Type RO, reset 0x0000.0000

	31	30	29	28	27	26	25	24	23	22	21	20	19	18	17	16
	reserved															
Type	RO	RO	RO	RO	RO	RO	RO	RO	RO	RO	RO	RO	RO	RO	RO	RO
Reset	0	0	0	0	0	0	0	0	0	0	0	0	0	0	0	0
	15	14	13	12	11	10	9	8	7	6	5	4	3	2	1	0
	reserved															LOCK
Type	RO	RO	RO	RO	RO	RO	RO	RO	RO	RO	RO	RO	RO	RO	RO	RO
Reset	0	0	0	0	0	0	0	0	0	0	0	0	0	0	0	0

Bit/Field	Name	Type	Reset	Description
31:1	reserved	RO	0x0000.000	Software should not rely on the value of a reserved bit. To provide compatibility with future products, the value of a reserved bit should be preserved across a read-modify-write operation.
0	LOCK	RO	0x0	PLL Lock
				Value Description
				1 The PLL powered and locked.
				0 The PLL is unpowered or is not yet locked.

Register 18: Watchdog Timer Peripheral Present (PPWD), offset 0x300

The **PPWD** register provides software information regarding the watchdog modules.

Important: This register should be used to determine which watchdog timers are implemented on this microcontroller. However, to support legacy software, the **DC1** register is available. A read of the **DC1** register correctly identifies if a legacy module is present.

Watchdog Timer Peripheral Present (PPWD)

Base 0x400F.E000

Offset 0x300

Type RO, reset 0x0000.0003

	31	30	29	28	27	26	25	24	23	22	21	20	19	18	17	16	
	reserved																
Type	RO	RO	RO	RO	RO	RO	RO	RO	RO	RO	RO	RO	RO	RO	RO	RO	
Reset	0	0	0	0	0	0	0	0	0	0	0	0	0	0	0	0	
	15	14	13	12	11	10	9	8	7	6	5	4	3	2	1	0	
	reserved															P1	P0
Type	RO	RO	RO	RO	RO	RO	RO	RO	RO	RO	RO	RO	RO	RO	RO	RO	RO
Reset	0	0	0	0	0	0	0	0	0	0	0	0	0	0	0	1	1

Bit/Field	Name	Type	Reset	Description
31:2	reserved	RO	0	Software should not rely on the value of a reserved bit. To provide compatibility with future products, the value of a reserved bit should be preserved across a read-modify-write operation.
1	P1	RO	0x1	Watchdog Timer 1 Present Value Description 1 Watchdog module 1 is present. 0 Watchdog module 1 is not present.
0	P0	RO	0x1	Watchdog Timer 0 Present Value Description 1 Watchdog module 0 is present. 0 Watchdog module 0 is not present.

Register 19: 16/32-Bit General-Purpose Timer Peripheral Present (PPTIMER), offset 0x304

The **PPTIMER** register provides software information regarding the 16/32-bit general-purpose timer modules.

Important: This register should be used to determine which timers are implemented on this microcontroller. However, to support legacy software, the **DC2** register is available. A read of the **DC2** register correctly identifies if a legacy module is present. Software must use this register to determine if a module that is not supported by the **DC2** register is present.

16/32-Bit General-Purpose Timer Peripheral Present (PPTIMER)

Base 0x400F.E000
 Offset 0x304
 Type RO, reset 0x0000.003F

	31	30	29	28	27	26	25	24	23	22	21	20	19	18	17	16	
	reserved																
Type	RO	RO	RO	RO	RO	RO	RO	RO	RO	RO	RO	RO	RO	RO	RO	RO	
Reset	0	0	0	0	0	0	0	0	0	0	0	0	0	0	0	0	
	15	14	13	12	11	10	9	8	7	6	5	4	3	2	1	0	
	reserved											P5	P4	P3	P2	P1	P0
Type	RO	RO	RO	RO	RO	RO	RO	RO	RO	RO	RO	RO	RO	RO	RO	RO	
Reset	0	0	0	0	0	0	0	0	0	0	1	1	1	1	1	1	

Bit/Field	Name	Type	Reset	Description
31:6	reserved	RO	0	Software should not rely on the value of a reserved bit. To provide compatibility with future products, the value of a reserved bit should be preserved across a read-modify-write operation.
5	P5	RO	0x1	16/32-Bit General-Purpose Timer 5 Present Value Description 1 16/32-bit general-purpose timer module 5 is present. 0 16/32-bit general-purpose timer module 6 is not present.
4	P4	RO	0x1	16/32-Bit General-Purpose Timer 4 Present Value Description 1 16/32-bit general-purpose timer module 4 is present. 0 16/32-bit general-purpose timer module 4 is not present.
3	P3	RO	0x1	16/32-Bit General-Purpose Timer 3 Present Value Description 1 16/32-bit general-purpose timer module 3 is present. 0 16/32-bit general-purpose timer module 3 is not present.

Bit/Field	Name	Type	Reset	Description
2	P2	RO	0x1	16/32-Bit General-Purpose Timer 2 Present Value Description 1 16/32-bit general-purpose timer module 2 is present. 0 16/32-bit general-purpose timer module 2 is not present.
1	P1	RO	0x1	16/32-Bit General-Purpose Timer 1 Present Value Description 1 16/32-bit general-purpose timer module 1 is present. 0 16/32-bit general-purpose timer module 1 is not present.
0	P0	RO	0x1	16/32-Bit General-Purpose Timer 0 Present Value Description 1 16/32-bit general-purpose timer module 0 is present. 0 16/32-bit general-purpose timer module 0 is not present.

Register 20: General-Purpose Input/Output Peripheral Present (PPGPIO), offset 0x308

The **PPGPIO** register provides software information regarding the general-purpose input/output modules.

Important: This register should be used to determine which GPIO ports are implemented on this microcontroller. However, to support legacy software, the **DC4** register is available. A read of the **DC4** register correctly identifies if a legacy module is present. Software must use this register to determine if a module that is not supported by the **DC4** register is present.

General-Purpose Input/Output Peripheral Present (PPGPIO)

Base 0x400F.E000
 Offset 0x308
 Type RO, reset 0x0000.007F

	31	30	29	28	27	26	25	24	23	22	21	20	19	18	17	16
	reserved															
Type	RO	RO	RO	RO	RO	RO	RO	RO	RO	RO	RO	RO	RO	RO	RO	RO
Reset	0	0	0	0	0	0	0	0	0	0	0	0	0	0	0	0
	15	14	13	12	11	10	9	8	7	6	5	4	3	2	1	0
	reserved	P14	P13	P12	P11	P10	P9	P8	P7	P6	P5	P4	P3	P2	P1	P0
Type	RO	RO	RO	RO	RO	RO	RO	RO	RO	RO	RO	RO	RO	RO	RO	RO
Reset	0	0	0	0	0	0	0	0	0	1	1	1	1	1	1	1

Bit/Field	Name	Type	Reset	Description
31:15	reserved	RO	0	Software should not rely on the value of a reserved bit. To provide compatibility with future products, the value of a reserved bit should be preserved across a read-modify-write operation.
14	P14	RO	0x0	GPIO Port Q Present Value Description 1 GPIO Port Q is present. 0 GPIO Port Q is not present.
13	P13	RO	0x0	GPIO Port P Present Value Description 1 GPIO Port P is present. 0 GPIO Port P is not present.
12	P12	RO	0x0	GPIO Port N Present Value Description 1 GPIO Port N is present. 0 GPIO Port N is not present.

Bit/Field	Name	Type	Reset	Description
11	P11	RO	0x0	GPIO Port M Present Value Description 1 GPIO Port M is present. 0 GPIO Port M is not present.
10	P10	RO	0x0	GPIO Port L Present Value Description 1 GPIO Port L is present. 0 GPIO Port L is not present.
9	P9	RO	0x0	GPIO Port K Present Value Description 1 GPIO Port K is present. 0 GPIO Port K is not present.
8	P8	RO	0x0	GPIO Port J Present Value Description 1 GPIO Port J is present. 0 GPIO Port J is not present.
7	P7	RO	0x0	GPIO Port H Present Value Description 1 GPIO Port H is present. 0 GPIO Port H is not present.
6	P6	RO	0x1	GPIO Port G Present Value Description 1 GPIO Port G is present. 0 GPIO Port G is not present.
5	P5	RO	0x1	GPIO Port F Present Value Description 1 GPIO Port F is present. 0 GPIO Port F is not present.

Bit/Field	Name	Type	Reset	Description
4	P4	RO	0x1	GPIO Port E Present Value Description 1 GPIO Port E is present. 0 GPIO Port E is not present.
3	P3	RO	0x1	GPIO Port D Present Value Description 1 GPIO Port D is present. 0 GPIO Port D is not present.
2	P2	RO	0x1	GPIO Port C Present Value Description 1 GPIO Port C is present. 0 GPIO Port C is not present.
1	P1	RO	0x1	GPIO Port B Present Value Description 1 GPIO Port B is present. 0 GPIO Port B is not present.
0	P0	RO	0x1	GPIO Port A Present Value Description 1 GPIO Port A is present. 0 GPIO Port A is not present.

Register 21: Micro Direct Memory Access Peripheral Present (PPDMA), offset 0x30C

The **PPDMA** register provides software information regarding the μ DMA module.

Important: This register should be used to determine if the μ DMA module is implemented on this microcontroller. However, to support legacy software, the **DC7** register is available. A read of the **DC7** register correctly identifies if the μ DMA module is present.

Micro Direct Memory Access Peripheral Present (PPDMA)

Base 0x400F.E000

Offset 0x30C

Type RO, reset 0x0000.0001

	31	30	29	28	27	26	25	24	23	22	21	20	19	18	17	16
	reserved															
Type	RO	RO	RO	RO	RO	RO	RO	RO	RO	RO	RO	RO	RO	RO	RO	RO
Reset	0	0	0	0	0	0	0	0	0	0	0	0	0	0	0	0
	15	14	13	12	11	10	9	8	7	6	5	4	3	2	1	0
	reserved															P0
Type	RO	RO	RO	RO	RO	RO	RO	RO	RO	RO	RO	RO	RO	RO	RO	RO
Reset	0	0	0	0	0	0	0	0	0	0	0	0	0	0	0	1

Bit/Field	Name	Type	Reset	Description
31:1	reserved	RO	0	Software should not rely on the value of a reserved bit. To provide compatibility with future products, the value of a reserved bit should be preserved across a read-modify-write operation.
0	P0	RO	0x1	μ DMA Module Present
				Value Description
				1 μ DMA module is present.
				0 μ DMA module is not present.

Register 22: Hibernation Peripheral Present (PPHIB), offset 0x314

The **PPHIB** register provides software information regarding the Hibernation module.

Important: This register should be used to determine if the Hibernation module is implemented on this microcontroller. However, to support legacy software, the **DC1** register is available. A read of the **DC1** register correctly identifies if the Hibernation module is present.

Hibernation Peripheral Present (PPHIB)

Base 0x400F.E000
 Offset 0x314
 Type RO, reset 0x0000.0000

	31	30	29	28	27	26	25	24	23	22	21	20	19	18	17	16
	reserved															
Type	RO	RO	RO	RO	RO	RO	RO	RO	RO	RO	RO	RO	RO	RO	RO	RO
Reset	0	0	0	0	0	0	0	0	0	0	0	0	0	0	0	0
	15	14	13	12	11	10	9	8	7	6	5	4	3	2	1	0
	reserved															P0
Type	RO	RO	RO	RO	RO	RO	RO	RO	RO	RO	RO	RO	RO	RO	RO	RO
Reset	0	0	0	0	0	0	0	0	0	0	0	0	0	0	0	0

Bit/Field	Name	Type	Reset	Description
31:1	reserved	RO	0	Software should not rely on the value of a reserved bit. To provide compatibility with future products, the value of a reserved bit should be preserved across a read-modify-write operation.
0	P0	RO	0x0	Hibernation Module Present
				Value Description
				1 Hibernation module is present.
				0 Hibernation module is not present.

Register 23: Universal Asynchronous Receiver/Transmitter Peripheral Present (PPUART), offset 0x318

The **PPUART** register provides software information regarding the UART modules.

Important: This register should be used to determine which UART modules are implemented on this microcontroller. However, to support legacy software, the **DC2** register is available. A read of the **DC2** register correctly identifies if a legacy UART module is present. Software must use this register to determine if a module that is not supported by the **DC2** register is present.

Universal Asynchronous Receiver/Transmitter Peripheral Present (PPUART)

Base 0x400F.E000
Offset 0x318
Type RO, reset 0x0000.00FF

	31	30	29	28	27	26	25	24	23	22	21	20	19	18	17	16
	reserved															
Type	RO	RO	RO	RO	RO	RO	RO	RO	RO	RO	RO	RO	RO	RO	RO	RO
Reset	0	0	0	0	0	0	0	0	0	0	0	0	0	0	0	0
	15	14	13	12	11	10	9	8	7	6	5	4	3	2	1	0
	reserved								P7	P6	P5	P4	P3	P2	P1	P0
Type	RO	RO	RO	RO	RO	RO	RO	RO	RO	RO	RO	RO	RO	RO	RO	RO
Reset	0	0	0	0	0	0	0	0	1	1	1	1	1	1	1	1

Bit/Field	Name	Type	Reset	Description
31:8	reserved	RO	0	Software should not rely on the value of a reserved bit. To provide compatibility with future products, the value of a reserved bit should be preserved across a read-modify-write operation.
7	P7	RO	0x1	UART Module 7 Present Value Description 1 UART module 7 is present. 0 UART module 7 is not present.
6	P6	RO	0x1	UART Module 6 Present Value Description 1 UART module 6 is present. 0 UART module 6 is not present.
5	P5	RO	0x1	UART Module 5 Present Value Description 1 UART module 5 is present. 0 UART module 5 is not present.

Bit/Field	Name	Type	Reset	Description
4	P4	RO	0x1	UART Module 4 Present Value Description 1 UART module 4 is present. 0 UART module 4 is not present.
3	P3	RO	0x1	UART Module 3 Present Value Description 1 UART module 3 is present. 0 UART module 3 is not present.
2	P2	RO	0x1	UART Module 2 Present Value Description 1 UART module 2 is present. 0 UART module 2 is not present.
1	P1	RO	0x1	UART Module 1 Present Value Description 1 UART module 1 is present. 0 UART module 1 is not present.
0	P0	RO	0x1	UART Module 0 Present Value Description 1 UART module 0 is present. 0 UART module 0 is not present.

Register 24: Synchronous Serial Interface Peripheral Present (PPSSI), offset 0x31C

The **PPSSI** register provides software information regarding the SSI modules.

Important: This register should be used to determine which SSI modules are implemented on this microcontroller. However, to support legacy software, the **DC2** register is available. A read of the **DC2** register correctly identifies if a legacy SSI module is present. Software must use this register to determine if a module that is not supported by the **DC2** register is present.

Synchronous Serial Interface Peripheral Present (PPSSI)

Base 0x400F.E000

Offset 0x31C

Type RO, reset 0x0000.000F

	31	30	29	28	27	26	25	24	23	22	21	20	19	18	17	16	
	reserved																
Type	RO	RO	RO	RO	RO	RO	RO	RO	RO	RO	RO	RO	RO	RO	RO	RO	
Reset	0	0	0	0	0	0	0	0	0	0	0	0	0	0	0	0	
	15	14	13	12	11	10	9	8	7	6	5	4	3	2	1	0	
	reserved													P3	P2	P1	P0
Type	RO	RO	RO	RO	RO	RO	RO	RO	RO	RO	RO	RO	RO	RO	RO	RO	
Reset	0	0	0	0	0	0	0	0	0	0	0	0	1	1	1	1	

Bit/Field	Name	Type	Reset	Description
31:4	reserved	RO	0	Software should not rely on the value of a reserved bit. To provide compatibility with future products, the value of a reserved bit should be preserved across a read-modify-write operation.
3	P3	RO	0x1	SSI Module 3 Present Value Description 1 SSI module 3 is present. 0 SSI module 3 is not present.
2	P2	RO	0x1	SSI Module 2 Present Value Description 1 SSI module 2 is present. 0 SSI module 2 is not present.
1	P1	RO	0x1	SSI Module 1 Present Value Description 1 SSI module 1 is present. 0 SSI module 1 is not present.

Bit/Field	Name	Type	Reset	Description
0	P0	RO	0x1	SSI Module 0 Present
				Value Description
				1 SSI module 0 is present.
				0 SSI module 0 is not present.

Register 25: Inter-Integrated Circuit Peripheral Present (PPI2C), offset 0x320

The **PPI2C** register provides software information regarding the I²C modules.

Important: This register should be used to determine which I²C modules are implemented on this microcontroller. However, to support legacy software, the **DC2** register is available. A read of the **DC2** register correctly identifies if a legacy I²C module is present. Software must use this register to determine if a module that is not supported by the **DC2** register is present.

Inter-Integrated Circuit Peripheral Present (PPI2C)

Base 0x400F.E000

Offset 0x320

Type RO, reset 0x0000.003F

	31	30	29	28	27	26	25	24	23	22	21	20	19	18	17	16	
	reserved																
Type	RO	RO	RO	RO	RO	RO	RO	RO	RO	RO	RO	RO	RO	RO	RO	RO	
Reset	0	0	0	0	0	0	0	0	0	0	0	0	0	0	0	0	
	15	14	13	12	11	10	9	8	7	6	5	4	3	2	1	0	
	reserved											P5	P4	P3	P2	P1	P0
Type	RO	RO	RO	RO	RO	RO	RO	RO	RO	RO	RO	RO	RO	RO	RO	RO	
Reset	0	0	0	0	0	0	0	0	0	0	1	1	1	1	1	1	

Bit/Field	Name	Type	Reset	Description
31:6	reserved	RO	0	Software should not rely on the value of a reserved bit. To provide compatibility with future products, the value of a reserved bit should be preserved across a read-modify-write operation.
5	P5	RO	0x1	I ² C Module 5 Present Value Description 1 I ² C module 5 is present. 0 I ² C module 5 is not present.
4	P4	RO	0x1	I ² C Module 4 Present Value Description 1 I ² C module 4 is present. 0 I ² C module 4 is not present.
3	P3	RO	0x1	I ² C Module 3 Present Value Description 1 I ² C module 3 is present. 0 I ² C module 3 is not present.

Bit/Field	Name	Type	Reset	Description
2	P2	RO	0x1	I ² C Module 2 Present Value Description 1 I ² C module 2 is present. 0 I ² C module 2 is not present.
1	P1	RO	0x1	I ² C Module 1 Present Value Description 1 I ² C module 1 is present. 0 I ² C module 1 is not present.
0	P0	RO	0x1	I ² C Module 0 Present Value Description 1 I ² C module 0 is present. 0 I ² C module 0 is not present.

Register 26: Universal Serial Bus Peripheral Present (PPUSB), offset 0x328

The **PPUSB** register provides software information regarding the USB module.

Important: This register should be used to determine if the USB module is implemented on this microcontroller. However, to support legacy software, the **DC6** register is available. A read of the **DC6** register correctly identifies if the USB module is present.

Universal Serial Bus Peripheral Present (PPUSB)

Base 0x400F.E000

Offset 0x328

Type RO, reset 0x0000.0001

	31	30	29	28	27	26	25	24	23	22	21	20	19	18	17	16
	reserved															
Type	RO	RO	RO	RO	RO	RO	RO	RO	RO	RO	RO	RO	RO	RO	RO	RO
Reset	0	0	0	0	0	0	0	0	0	0	0	0	0	0	0	0
	15	14	13	12	11	10	9	8	7	6	5	4	3	2	1	0
	reserved															P0
Type	RO	RO	RO	RO	RO	RO	RO	RO	RO	RO	RO	RO	RO	RO	RO	RO
Reset	0	0	0	0	0	0	0	0	0	0	0	0	0	0	0	1

Bit/Field	Name	Type	Reset	Description
31:1	reserved	RO	0	Software should not rely on the value of a reserved bit. To provide compatibility with future products, the value of a reserved bit should be preserved across a read-modify-write operation.
0	P0	RO	0x1	USB Module Present
				Value Description
				1 USB module is present.
				0 USB module is not present.

Register 27: Controller Area Network Peripheral Present (PPCAN), offset 0x334

The **PPCAN** register provides software information regarding the CAN modules.

Important: This register should be used to determine which CAN modules are implemented on this microcontroller. However, to support legacy software, the **DC1** register is available. A read of the **DC1** register correctly identifies if a legacy CAN module is present.

Controller Area Network Peripheral Present (PPCAN)

Base 0x400F.E000
 Offset 0x334
 Type RO, reset 0x0000.0003

	31	30	29	28	27	26	25	24	23	22	21	20	19	18	17	16	
	reserved																
Type	RO	RO	RO	RO	RO	RO	RO	RO	RO	RO	RO	RO	RO	RO	RO	RO	
Reset	0	0	0	0	0	0	0	0	0	0	0	0	0	0	0	0	
	15	14	13	12	11	10	9	8	7	6	5	4	3	2	1	0	
	reserved															P1	P0
Type	RO	RO	RO	RO	RO	RO	RO	RO	RO	RO	RO	RO	RO	RO	RO	RO	RO
Reset	0	0	0	0	0	0	0	0	0	0	0	0	0	0	0	1	1

Bit/Field	Name	Type	Reset	Description
31:2	reserved	RO	0	Software should not rely on the value of a reserved bit. To provide compatibility with future products, the value of a reserved bit should be preserved across a read-modify-write operation.
1	P1	RO	0x1	CAN Module 1 Present Value Description 1 CAN module 1 is present. 0 CAN module 1 is not present.
0	P0	RO	0x1	CAN Module 0 Present Value Description 1 CAN module 0 is present. 0 CAN module 0 is not present.

Register 28: Analog-to-Digital Converter Peripheral Present (PPADC), offset 0x338

The **PPADC** register provides software information regarding the ADC modules.

Important: This register should be used to determine which ADC modules are implemented on this microcontroller. However, to support legacy software, the **DC1** register is available. A read of the **DC1** register correctly identifies if a legacy ADC module is present.

Analog-to-Digital Converter Peripheral Present (PPADC)

Base 0x400F.E000

Offset 0x338

Type RO, reset 0x0000.0003

	31	30	29	28	27	26	25	24	23	22	21	20	19	18	17	16	
	reserved																
Type	RO	RO	RO	RO	RO	RO	RO	RO	RO	RO	RO	RO	RO	RO	RO	RO	
Reset	0	0	0	0	0	0	0	0	0	0	0	0	0	0	0	0	
	15	14	13	12	11	10	9	8	7	6	5	4	3	2	1	0	
	reserved															P1	P0
Type	RO	RO	RO	RO	RO	RO	RO	RO	RO	RO	RO	RO	RO	RO	RO	RO	RO
Reset	0	0	0	0	0	0	0	0	0	0	0	0	0	0	1	1	

Bit/Field	Name	Type	Reset	Description
31:2	reserved	RO	0	Software should not rely on the value of a reserved bit. To provide compatibility with future products, the value of a reserved bit should be preserved across a read-modify-write operation.
1	P1	RO	0x1	ADC Module 1 Present Value Description 1 ADC module 1 is present. 0 ADC module 1 is not present.
0	P0	RO	0x1	ADC Module 0 Present Value Description 1 ADC module 0 is present. 0 ADC module 0 is not present.

Register 29: Analog Comparator Peripheral Present (PPACMP), offset 0x33C

The **PPACMP** register provides software information regarding the analog comparator module.

Important: This register should be used to determine if the analog comparator module is implemented on this microcontroller. However, to support legacy software, the **DC2** register is available. A read of the **DC2** register correctly identifies if the analog comparator module is present.

Note that the **Analog Comparator Peripheral Properties (ACMPPP)** register indicates how many analog comparator blocks are included in the module.

Analog Comparator Peripheral Present (PPACMP)

Base 0x400F.E000
 Offset 0x33C
 Type RO, reset 0x0000.0001

	31	30	29	28	27	26	25	24	23	22	21	20	19	18	17	16
	reserved															
Type	RO	RO	RO	RO	RO	RO	RO	RO	RO	RO	RO	RO	RO	RO	RO	RO
Reset	0	0	0	0	0	0	0	0	0	0	0	0	0	0	0	0
	15	14	13	12	11	10	9	8	7	6	5	4	3	2	1	0
	reserved															P0
Type	RO	RO	RO	RO	RO	RO	RO	RO	RO	RO	RO	RO	RO	RO	RO	RO
Reset	0	0	0	0	0	0	0	0	0	0	0	0	0	0	0	1

Bit/Field	Name	Type	Reset	Description	
31:1	reserved	RO	0	Software should not rely on the value of a reserved bit. To provide compatibility with future products, the value of a reserved bit should be preserved across a read-modify-write operation.	
0	P0	RO	0x1	Analog Comparator Module Present	
Value Description					
	1	Analog comparator module is present.			
	0	Analog comparator module is not present.			

Register 30: Pulse Width Modulator Peripheral Present (PPPWM), offset 0x340

The **PPPWM** register provides software information regarding the PWM modules.

Important: This register should be used to determine which PWM modules are implemented on this microcontroller. However, to support legacy software, the **DC1** register is available. A read of the **DC1** register correctly identifies if the legacy PWM module is present. Software must use this register to determine if a module that is not supported by the **DC1** register is present.

Pulse Width Modulator Peripheral Present (PPPWM)

Base 0x400F.E000

Offset 0x340

Type RO, reset 0x0000.0003

	31	30	29	28	27	26	25	24	23	22	21	20	19	18	17	16	
	reserved																
Type	RO	RO	RO	RO	RO	RO	RO	RO	RO	RO	RO	RO	RO	RO	RO	RO	
Reset	0	0	0	0	0	0	0	0	0	0	0	0	0	0	0	0	
	15	14	13	12	11	10	9	8	7	6	5	4	3	2	1	0	
	reserved															P1	P0
Type	RO	RO	RO	RO	RO	RO	RO	RO	RO	RO	RO	RO	RO	RO	RO	RO	RO
Reset	0	0	0	0	0	0	0	0	0	0	0	0	0	0	0	1	1

Bit/Field	Name	Type	Reset	Description
31:2	reserved	RO	0	Software should not rely on the value of a reserved bit. To provide compatibility with future products, the value of a reserved bit should be preserved across a read-modify-write operation.
1	P1	RO	0x1	PWM Module 1 Present Value Description 1 PWM module 1 is present. 0 PWM module 1 is not present.
0	P0	RO	0x1	PWM Module 0 Present Value Description 1 PWM module 0 is present. 0 PWM module 0 is not present.

Register 31: Quadrature Encoder Interface Peripheral Present (PPQEI), offset 0x344

The **PPQEI** register provides software information regarding the QEI modules.

Important: This register should be used to determine which QEI modules are implemented on this microcontroller. However, to support legacy software, the **DC2** register is available. A read of the **DC2** register correctly identifies if a legacy QEI module is present.

Quadrature Encoder Interface Peripheral Present (PPQEI)

Base 0x400F.E000
 Offset 0x344
 Type RO, reset 0x0000.0003

	31	30	29	28	27	26	25	24	23	22	21	20	19	18	17	16	
	reserved																
Type	RO	RO	RO	RO	RO	RO	RO	RO	RO	RO	RO	RO	RO	RO	RO	RO	
Reset	0	0	0	0	0	0	0	0	0	0	0	0	0	0	0	0	
	15	14	13	12	11	10	9	8	7	6	5	4	3	2	1	0	
	reserved															P1	P0
Type	RO	RO	RO	RO	RO	RO	RO	RO	RO	RO	RO	RO	RO	RO	RO	RO	RO
Reset	0	0	0	0	0	0	0	0	0	0	0	0	0	0	1	1	

Bit/Field	Name	Type	Reset	Description
31:2	reserved	RO	0	Software should not rely on the value of a reserved bit. To provide compatibility with future products, the value of a reserved bit should be preserved across a read-modify-write operation.
1	P1	RO	0x1	QEI Module 1 Present Value Description 1 QEI module 1 is present. 0 QEI module 1 is not present.
0	P0	RO	0x1	QEI Module 0 Present Value Description 1 QEI module 0 is present. 0 QEI module 0 is not present.

Register 32: EEPROM Peripheral Present (PPEEPROM), offset 0x358

The **PPEEPROM** register provides software information regarding the EEPROM module.

EEPROM Peripheral Present (PPEEPROM)

Base 0x400F.E000

Offset 0x358

Type RO, reset 0x0000.0001

	31	30	29	28	27	26	25	24	23	22	21	20	19	18	17	16
	reserved															
Type	RO	RO	RO	RO	RO	RO	RO	RO	RO	RO	RO	RO	RO	RO	RO	RO
Reset	0	0	0	0	0	0	0	0	0	0	0	0	0	0	0	0
	15	14	13	12	11	10	9	8	7	6	5	4	3	2	1	0
	reserved															P0
Type	RO	RO	RO	RO	RO	RO	RO	RO	RO	RO	RO	RO	RO	RO	RO	RO
Reset	0	0	0	0	0	0	0	0	0	0	0	0	0	0	0	1

Bit/Field	Name	Type	Reset	Description
31:1	reserved	RO	0	Software should not rely on the value of a reserved bit. To provide compatibility with future products, the value of a reserved bit should be preserved across a read-modify-write operation.
0	P0	RO	0x1	EEPROM Module Present
				Value Description
				1 EEPROM module is present.
				0 EEPROM module is not present.

Register 33: 32/64-Bit Wide General-Purpose Timer Peripheral Present (PPWTIMER), offset 0x35C

The PPWTIMER register provides software information regarding the 32/64-bit wide general-purpose timer modules.

32/64-Bit Wide General-Purpose Timer Peripheral Present (PPWTIMER)

Base 0x400F.E000
 Offset 0x35C
 Type RO, reset 0x0000.003F

	31	30	29	28	27	26	25	24	23	22	21	20	19	18	17	16	
	reserved																
Type	RO	RO	RO	RO	RO	RO	RO	RO	RO	RO	RO	RO	RO	RO	RO	RO	
Reset	0	0	0	0	0	0	0	0	0	0	0	0	0	0	0	0	
	15	14	13	12	11	10	9	8	7	6	5	4	3	2	1	0	
	reserved											P5	P4	P3	P2	P1	P0
Type	RO	RO	RO	RO	RO	RO	RO	RO	RO	RO	RO	RO	RO	RO	RO	RO	
Reset	0	0	0	0	0	0	0	0	0	0	1	1	1	1	1	1	

Bit/Field	Name	Type	Reset	Description
31:6	reserved	RO	0	Software should not rely on the value of a reserved bit. To provide compatibility with future products, the value of a reserved bit should be preserved across a read-modify-write operation.
5	P5	RO	0x1	32/64-Bit Wide General-Purpose Timer 5 Present Value Description 1 32/64-bit wide general-purpose timer module 5 is present. 0 32/64-bit wide general-purpose timer module 5 is not present.
4	P4	RO	0x1	32/64-Bit Wide General-Purpose Timer 4 Present Value Description 1 32/64-bit wide general-purpose timer module 4 is present. 0 32/64-bit wide general-purpose timer module 4 is not present.
3	P3	RO	0x1	32/64-Bit Wide General-Purpose Timer 3 Present Value Description 1 32/64-bit wide general-purpose timer module 3 is present. 0 32/64-bit wide general-purpose timer module 3 is not present.
2	P2	RO	0x1	32/64-Bit Wide General-Purpose Timer 2 Present Value Description 1 32/64-bit wide general-purpose timer module 2 is present. 0 32/64-bit wide general-purpose timer module 2 is not present.

Bit/Field	Name	Type	Reset	Description
1	P1	RO	0x1	32/64-Bit Wide General-Purpose Timer 1 Present Value Description 1 32/64-bit wide general-purpose timer module 1 is present. 0 32/64-bit wide general-purpose timer module 1 is not present.
0	P0	RO	0x1	32/64-Bit Wide General-Purpose Timer 0 Present Value Description 1 32/64-bit wide general-purpose timer module 0 is present. 0 32/64-bit wide general-purpose timer module 0 is not present.

Register 34: Watchdog Timer Software Reset (SRWD), offset 0x500

The **SRWD** register provides software the capability to reset the available watchdog modules. This register provides the same capability as the legacy **Software Reset Control n SRCRn** registers specifically for the watchdog modules and has the same bit polarity as the corresponding **SRCRn** bits.

A peripheral is reset by software using a simple two-step process:

1. Software sets a bit (or bits) in the **SRWD** register. While the **SRWD** bit is 1, the peripheral is held in reset.
2. Software completes the reset process by clearing the **SRWD** bit.

There may be latency from the clearing of the **SRWD** bit to when the peripheral is ready for use. Software can check the corresponding **PRWD** bit to be sure.

Important: This register should be used to reset the watchdog modules. To support legacy software, the **SRCR0** register is available. Setting a bit in the **SRCR0** register also resets the corresponding module. Any bits that are changed by writing to the **SRCR0** register can be read back correctly when reading the **SRCR0** register. If software uses this register to reset a legacy peripheral (such as Watchdog 1), the write causes proper operation, but the value of that bit is not reflected in the **SRCR0** register. If software uses both legacy and peripheral-specific register accesses, the peripheral-specific registers must be accessed by read-modify-write operations that affect only peripherals that are not present in the legacy registers. In this manner, both the peripheral-specific and legacy registers have coherent information.

Watchdog Timer Software Reset (SRWD)

Base 0x400F.E000
 Offset 0x500
 Type R/W, reset 0x0000.0000

	31	30	29	28	27	26	25	24	23	22	21	20	19	18	17	16	
	reserved																
Type	RO	RO	RO	RO	RO	RO	RO	RO	RO	RO	RO	RO	RO	RO	RO	RO	
Reset	0	0	0	0	0	0	0	0	0	0	0	0	0	0	0	0	
	15	14	13	12	11	10	9	8	7	6	5	4	3	2	1	0	
	reserved															R1	R0
Type	RO	RO	RO	RO	RO	RO	RO	RO	RO	RO	RO	RO	RO	RO	RO	R/W	R/W
Reset	0	0	0	0	0	0	0	0	0	0	0	0	0	0	0	0	0

Bit/Field	Name	Type	Reset	Description
31:2	reserved	RO	0	Software should not rely on the value of a reserved bit. To provide compatibility with future products, the value of a reserved bit should be preserved across a read-modify-write operation.
1	R1	R/W	0	Watchdog Timer 1 Software Reset
				Value Description
			1	Watchdog module 1 is reset.
			0	Watchdog module 1 is not reset.

Bit/Field	Name	Type	Reset	Description
0	R0	R/W	0	Watchdog Timer 0 Software Reset
				Value Description
				1 Watchdog module 0 is reset.
				0 Watchdog module 0 is not reset.

Register 35: 16/32-Bit General-Purpose Timer Software Reset (SRTIMER), offset 0x504

The **SRTIMER** register provides software the capability to reset the available 16/32-bit timer modules. This register provides the same capability as the legacy **Software Reset Control n SRCRn** registers specifically for the timer modules and has the same bit polarity as the corresponding **SRCRn** bits.

A peripheral is reset by software using a simple two-step process:

1. Software sets a bit (or bits) in the **SRTIMER** register. While the **SRTIMER** bit is 1, the peripheral is held in reset.
2. Software completes the reset process by clearing the **SRTIMER** bit.

There may be latency from the clearing of the **SRTIMER** bit to when the peripheral is ready for use. Software can check the corresponding **PRTIMER** bit to be sure.

Important: This register should be used to reset the timer modules. To support legacy software, the **SRCR1** register is available. Setting a bit in the **SRCR1** register also resets the corresponding module. Any bits that are changed by writing to the **SRCR1** register can be read back correctly when reading the **SRCR1** register. Software must use this register to reset modules that are not present in the legacy registers. If software uses this register to reset a legacy peripheral (such as Timer 1), the write causes proper operation, but the value of that bit is not reflected in the **SRCR1** register. If software uses both legacy and peripheral-specific register accesses, the peripheral-specific registers must be accessed by read-modify-write operations that affect only peripherals that are not present in the legacy registers. In this manner, both the peripheral-specific and legacy registers have coherent information.

16/32-Bit General-Purpose Timer Software Reset (SRTIMER)

Base 0x400F.E000
 Offset 0x504
 Type R/W, reset 0x0000.0000

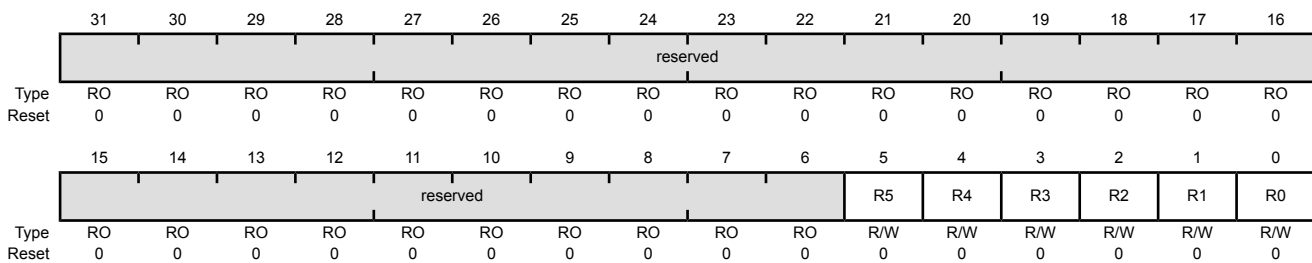

Bit/Field	Name	Type	Reset	Description
31:6	reserved	RO	0	Software should not rely on the value of a reserved bit. To provide compatibility with future products, the value of a reserved bit should be preserved across a read-modify-write operation.
5	R5	R/W	0	16/32-Bit General-Purpose Timer 5 Software Reset
				Value Description
				1 16/32-bit general-purpose timer module 5 is reset.
				0 16/32-bit general-purpose timer module 5 is not reset.

Bit/Field	Name	Type	Reset	Description
4	R4	R/W	0	16/32-Bit General-Purpose Timer 4 Software Reset Value Description 1 16/32-bit general-purpose timer module 4 is reset. 0 16/32-bit general-purpose timer module 4 is not reset.
3	R3	R/W	0	16/32-Bit General-Purpose Timer 3 Software Reset Value Description 1 16/32-bit general-purpose timer module 3 is reset. 0 16/32-bit general-purpose timer module 3 is not reset.
2	R2	R/W	0	16/32-Bit General-Purpose Timer 2 Software Reset Value Description 1 16/32-bit general-purpose timer module 2 is reset. 0 16/32-bit general-purpose timer module 2 is not reset.
1	R1	R/W	0	16/32-Bit General-Purpose Timer 1 Software Reset Value Description 1 16/32-bit general-purpose timer module 1 is reset. 0 16/32-bit general-purpose timer module 1 is not reset.
0	R0	R/W	0	16/32-Bit General-Purpose Timer 0 Software Reset Value Description 1 16/32-bit general-purpose timer module 0 is reset. 0 16/32-bit general-purpose timer module 0 is not reset.

Register 36: General-Purpose Input/Output Software Reset (SRGPIO), offset 0x508

The **SRGPIO** register provides software the capability to reset the available GPIO modules. This register provides the same capability as the legacy **Software Reset Control n SRCRn** registers specifically for the GPIO modules and has the same bit polarity as the corresponding **SRCRn** bits.

A peripheral is reset by software using a simple two-step process:

1. Software sets a bit (or bits) in the **SRGPIO** register. While the **SRGPIO** bit is 1, the peripheral is held in reset.
2. Software completes the reset process by clearing the **SRGPIO** bit.

There may be latency from the clearing of the **SRGPIO** bit to when the peripheral is ready for use. Software can check the corresponding **PRGPIO** bit to be sure.

Important: This register should be used to reset the GPIO modules. To support legacy software, the **SRCR2** register is available. Setting a bit in the **SRCR2** register also resets the corresponding module. Any bits that are changed by writing to the **SRCR2** register can be read back correctly when reading the **SRCR2** register. Software must use this register to reset modules that are not present in the legacy registers. If software uses this register to reset a legacy peripheral (such as GPIO A), the write causes proper operation, but the value of that bit is not reflected in the **SRCR2** register. If software uses both legacy and peripheral-specific register accesses, the peripheral-specific registers must be accessed by read-modify-write operations that affect only peripherals that are not present in the legacy registers. In this manner, both the peripheral-specific and legacy registers have coherent information.

General-Purpose Input/Output Software Reset (SRGPIO)

Base 0x400F.E000
 Offset 0x508
 Type R/W, reset 0x0000.0000

	31	30	29	28	27	26	25	24	23	22	21	20	19	18	17	16	
	reserved																
Type	RO	RO	RO	RO	RO	RO	RO	RO	RO	RO	RO	RO	RO	RO	RO	RO	
Reset	0	0	0	0	0	0	0	0	0	0	0	0	0	0	0	0	
	15	14	13	12	11	10	9	8	7	6	5	4	3	2	1	0	
	reserved										R6	R5	R4	R3	R2	R1	R0
Type	RO	RO	RO	RO	RO	RO	RO	RO	RO	RO	R/W	R/W	R/W	R/W	R/W	R/W	
Reset	0	0	0	0	0	0	0	0	0	0	0	0	0	0	0	0	

Bit/Field	Name	Type	Reset	Description
31:7	reserved	RO	0	Software should not rely on the value of a reserved bit. To provide compatibility with future products, the value of a reserved bit should be preserved across a read-modify-write operation.
6	R6	R/W	0	GPIO Port G Software Reset
				Value Description
				1 GPIO Port G is reset.
				0 GPIO Port G is not reset.

Bit/Field	Name	Type	Reset	Description
5	R5	R/W	0	GPIO Port F Software Reset Value Description 1 GPIO Port F is reset. 0 GPIO Port F is not reset.
4	R4	R/W	0	GPIO Port E Software Reset Value Description 1 GPIO Port E is reset. 0 GPIO Port E is not reset.
3	R3	R/W	0	GPIO Port D Software Reset Value Description 1 GPIO Port D is reset. 0 GPIO Port D is not reset.
2	R2	R/W	0	GPIO Port C Software Reset Value Description 1 GPIO Port C is reset. 0 GPIO Port C is not reset.
1	R1	R/W	0	GPIO Port B Software Reset Value Description 1 GPIO Port B is reset. 0 GPIO Port B is not reset.
0	R0	R/W	0	GPIO Port A Software Reset Value Description 1 GPIO Port A is reset. 0 GPIO Port A is not reset.

Register 37: Micro Direct Memory Access Software Reset (SRDMA), offset 0x50C

The **SRDMA** register provides software the capability to reset the available μ DMA module. This register provides the same capability as the legacy **Software Reset Control n SRCRn** registers specifically for the μ DMA module and has the same bit polarity as the corresponding **SRCRn** bits.

A peripheral is reset by software using a simple two-step process:

1. Software sets a bit (or bits) in the **SRDMA** register. While the **SRDMA** bit is 1, the peripheral is held in reset.
2. Software completes the reset process by clearing the **SRDMA** bit.

There may be latency from the clearing of the **SRDMA** bit to when the peripheral is ready for use. Software can check the corresponding **PRDMA** bit to be sure.

Important: This register should be used to reset the μ DMA module. To support legacy software, the **SRCR2** register is available. Setting the **UDMA** bit in the **SRCR2** register also resets the μ DMA module. If the **UDMA** bit is set by writing to the **SRCR2** register, it can be read back correctly when reading the **SRCR2** register. If software uses this register to reset the μ DMA module, the write causes proper operation, but the value of the **UDMA** bit is not reflected in the **SRCR2** register. If software uses both legacy and peripheral-specific register accesses, the peripheral-specific registers must be accessed by read-modify-write operations that affect only peripherals that are not present in the legacy registers. In this manner, both the peripheral-specific and legacy registers have coherent information.

Micro Direct Memory Access Software Reset (SRDMA)

Base 0x400F.E000
 Offset 0x50C
 Type R/W, reset 0x0000.0000

	31	30	29	28	27	26	25	24	23	22	21	20	19	18	17	16
	reserved															
Type	RO	RO	RO	RO	RO	RO	RO	RO	RO	RO	RO	RO	RO	RO	RO	RO
Reset	0	0	0	0	0	0	0	0	0	0	0	0	0	0	0	0
	15	14	13	12	11	10	9	8	7	6	5	4	3	2	1	0
	reserved															RO
Type	RO	RO	RO	RO	RO	RO	RO	RO	RO	RO	RO	RO	RO	RO	RO	R/W
Reset	0	0	0	0	0	0	0	0	0	0	0	0	0	0	0	0

Bit/Field	Name	Type	Reset	Description
31:1	reserved	RO	0	Software should not rely on the value of a reserved bit. To provide compatibility with future products, the value of a reserved bit should be preserved across a read-modify-write operation.
0	R0	R/W	0	μ DMA Module Software Reset
	Value	Description		
	1	μ DMA module is reset.		
	0	μ DMA module is not reset.		

Register 38: Universal Asynchronous Receiver/Transmitter Software Reset (SRUART), offset 0x518

The **SRUART** register provides software the capability to reset the available UART modules. This register provides the same capability as the legacy **Software Reset Control n SRCRn** registers specifically for the UART modules and has the same bit polarity as the corresponding **SRCRn** bits.

A peripheral is reset by software using a simple two-step process:

1. Software sets a bit (or bits) in the **SRUART** register. While the **SRUART** bit is 1, the peripheral is held in reset.
2. Software completes the reset process by clearing the **SRUART** bit.

There may be latency from the clearing of the **SRUART** bit to when the peripheral is ready for use. Software can check the corresponding **PRUART** bit to be sure.

Important: This register should be used to reset the UART modules. To support legacy software, the **SRCR1** register is available. Setting a bit in the **SRCR1** register also resets the corresponding module. Any bits that are changed by writing to the **SRCR1** register can be read back correctly when reading the **SRCR1** register. Software must use this register to reset modules that are not present in the legacy registers. If software uses this register to reset a legacy peripheral (such as UART0), the write causes proper operation, but the value of that bit is not reflected in the **SRCR1** register. If software uses both legacy and peripheral-specific register accesses, the peripheral-specific registers must be accessed by read-modify-write operations that affect only peripherals that are not present in the legacy registers. In this manner, both the peripheral-specific and legacy registers have coherent information.

Universal Asynchronous Receiver/Transmitter Software Reset (SRUART)

Base 0x400F.E000
Offset 0x518
Type R/W, reset 0x0000.0000

	31	30	29	28	27	26	25	24	23	22	21	20	19	18	17	16
	reserved															
Type	RO	RO	RO	RO	RO	RO	RO	RO	RO	RO	RO	RO	RO	RO	RO	RO
Reset	0	0	0	0	0	0	0	0	0	0	0	0	0	0	0	0
	15	14	13	12	11	10	9	8	7	6	5	4	3	2	1	0
	reserved								R7	R6	R5	R4	R3	R2	R1	R0
Type	RO	RO	RO	RO	RO	RO	RO	RO	R/W	R/W	R/W	R/W	R/W	R/W	R/W	R/W
Reset	0	0	0	0	0	0	0	0	0	0	0	0	0	0	0	0

Bit/Field	Name	Type	Reset	Description
31:8	reserved	RO	0	Software should not rely on the value of a reserved bit. To provide compatibility with future products, the value of a reserved bit should be preserved across a read-modify-write operation.
7	R7	R/W	0	UART Module 7 Software Reset
	Value	Description		
	1	UART module 7 is reset.		
	0	UART module 7 is not reset.		

Bit/Field	Name	Type	Reset	Description
6	R6	R/W	0	UART Module 6 Software Reset Value Description 1 UART module 6 is reset. 0 UART module 6 is not reset.
5	R5	R/W	0	UART Module 5 Software Reset Value Description 1 UART module 5 is reset. 0 UART module 5 is not reset.
4	R4	R/W	0	UART Module 4 Software Reset Value Description 1 UART module 4 is reset. 0 UART module 4 is not reset.
3	R3	R/W	0	UART Module 3 Software Reset Value Description 1 UART module 3 is reset. 0 UART module 3 is not reset.
2	R2	R/W	0	UART Module 2 Software Reset Value Description 1 UART module 2 is reset. 0 UART module 2 is not reset.
1	R1	R/W	0	UART Module 1 Software Reset Value Description 1 UART module 1 is reset. 0 UART module 1 is not reset.
0	R0	R/W	0	UART Module 0 Software Reset Value Description 1 UART module 0 is reset. 0 UART module 0 is not reset.

Register 39: Synchronous Serial Interface Software Reset (SRSSI), offset 0x51C

The **SRSSI** register provides software the capability to reset the available SSI modules. This register provides the same capability as the legacy **Software Reset Control n SRCRn** registers specifically for the SSI modules and has the same bit polarity as the corresponding **SRCRn** bits.

A peripheral is reset by software using a simple two-step process:

1. Software sets a bit (or bits) in the **SRSSI** register. While the **SRSSI** bit is 1, the peripheral is held in reset.
2. Software completes the reset process by clearing the **SRSSI** bit.

There may be latency from the clearing of the **SRSSI** bit to when the peripheral is ready for use. Software can check the corresponding **PRSSI** bit to be sure.

Important: This register should be used to reset the SSI modules. To support legacy software, the **SRCR1** register is available. Setting a bit in the **SRCR1** register also resets the corresponding module. Any bits that are changed by writing to the **SRCR1** register can be read back correctly when reading the **SRCR1** register. Software must use this register to reset modules that are not present in the legacy registers. If software uses this register to reset a legacy peripheral (such as SSI0), the write causes proper operation, but the value of that bit is not reflected in the **SRCR1** register. If software uses both legacy and peripheral-specific register accesses, the peripheral-specific registers must be accessed by read-modify-write operations that affect only peripherals that are not present in the legacy registers. In this manner, both the peripheral-specific and legacy registers have coherent information.

Synchronous Serial Interface Software Reset (SRSSI)

Base 0x400F.E000
Offset 0x51C
Type R/W, reset 0x0000.0000

	31	30	29	28	27	26	25	24	23	22	21	20	19	18	17	16
	reserved															
Type	RO	RO	RO	RO	RO	RO	RO	RO	RO	RO	RO	RO	RO	RO	RO	RO
Reset	0	0	0	0	0	0	0	0	0	0	0	0	0	0	0	0
	15	14	13	12	11	10	9	8	7	6	5	4	3	2	1	0
	reserved												R3	R2	R1	R0
Type	RO	RO	RO	RO	RO	RO	RO	RO	RO	RO	RO	RO	R/W	R/W	R/W	R/W
Reset	0	0	0	0	0	0	0	0	0	0	0	0	0	0	0	0

Bit/Field	Name	Type	Reset	Description
31:4	reserved	RO	0	Software should not rely on the value of a reserved bit. To provide compatibility with future products, the value of a reserved bit should be preserved across a read-modify-write operation.
3	R3	R/W	0	SSI Module 3 Software Reset
				Value Description
				1 SSI module 3 is reset.
				0 SSI module 3 is not reset.

Bit/Field	Name	Type	Reset	Description
2	R2	R/W	0	SSI Module 2 Software Reset Value Description 1 SSI module 2 is reset. 0 SSI module 2 is not reset.
1	R1	R/W	0	SSI Module 1 Software Reset Value Description 1 SSI module 1 is reset. 0 SSI module 1 is not reset.
0	R0	R/W	0	SSI Module 0 Software Reset Value Description 1 SSI module 0 is reset. 0 SSI module 0 is not reset.

Register 40: Inter-Integrated Circuit Software Reset (SRI2C), offset 0x520

The **SRI2C** register provides software the capability to reset the available I²C modules. This register provides the same capability as the legacy **Software Reset Control n SRCRn** registers specifically for the I²C modules and has the same bit polarity as the corresponding **SRCRn** bits.

A peripheral is reset by software using a simple two-step process:

1. Software sets a bit (or bits) in the **SRI2C** register. While the **SRI2C** bit is 1, the peripheral is held in reset.
2. Software completes the reset process by clearing the **SRI2C** bit.

There may be latency from the clearing of the **SRI2C** bit to when the peripheral is ready for use. Software can check the corresponding **PRI2C** bit to be sure.

Important: This register should be used to reset the I²C modules. To support legacy software, the **SRCR1** register is available. Setting a bit in the **SRCR1** register also resets the corresponding module. Any bits that are changed by writing to the **SRCR1** register can be read back correctly when reading the **SRCR1** register. Software must use this register to reset modules that are not present in the legacy registers. If software uses this register to reset a legacy peripheral (such as I2C0), the write causes proper operation, but the value of that bit is not reflected in the **SRCR1** register. If software uses both legacy and peripheral-specific register accesses, the peripheral-specific registers must be accessed by read-modify-write operations that affect only peripherals that are not present in the legacy registers. In this manner, both the peripheral-specific and legacy registers have coherent information.

Inter-Integrated Circuit Software Reset (SRI2C)

Base 0x400F.E000
Offset 0x520
Type R/W, reset 0x0000.0000

	31	30	29	28	27	26	25	24	23	22	21	20	19	18	17	16	
	reserved																
Type	RO	RO	RO	RO	RO	RO	RO	RO	RO	RO	RO	RO	RO	RO	RO	RO	
Reset	0	0	0	0	0	0	0	0	0	0	0	0	0	0	0	0	
	15	14	13	12	11	10	9	8	7	6	5	4	3	2	1	0	
	reserved											R5	R4	R3	R2	R1	R0
Type	RO	RO	RO	RO	RO	RO	RO	RO	RO	RO	R/W	R/W	R/W	R/W	R/W	R/W	
Reset	0	0	0	0	0	0	0	0	0	0	0	0	0	0	0	0	

Bit/Field	Name	Type	Reset	Description
31:6	reserved	RO	0	Software should not rely on the value of a reserved bit. To provide compatibility with future products, the value of a reserved bit should be preserved across a read-modify-write operation.
5	R5	R/W	0	I ² C Module 5 Software Reset
				Value Description
				1 I ² C module 5 is reset.
				0 I ² C module 5 is not reset.

Bit/Field	Name	Type	Reset	Description
4	R4	R/W	0	I ² C Module 4 Software Reset Value Description 1 I ² C module 4 is reset. 0 I ² C module 4 is not reset.
3	R3	R/W	0	I ² C Module 3 Software Reset Value Description 1 I ² C module 3 is reset. 0 I ² C module 3 is not reset.
2	R2	R/W	0	I ² C Module 2 Software Reset Value Description 1 I ² C module 2 is reset. 0 I ² C module 2 is not reset.
1	R1	R/W	0	I ² C Module 1 Software Reset Value Description 1 I ² C module 1 is reset. 0 I ² C module 1 is not reset.
0	R0	R/W	0	I ² C Module 0 Software Reset Value Description 1 I ² C module 0 is reset. 0 I ² C module 0 is not reset.

Register 41: Universal Serial Bus Software Reset (SRUSB), offset 0x528

The **SRUSB** register provides software the capability to reset the available USB module. This register provides the same capability as the legacy **Software Reset Control n SRCRn** registers specifically for the USB module and has the same bit polarity as the corresponding **SRCRn** bits.

A peripheral is reset by software using a simple two-step process:

1. Software sets a bit (or bits) in the **SRUSB** register. While the **SRUSB** bit is 1, the peripheral is held in reset.
2. Software completes the reset process by clearing the **SRUSB** bit.

There may be latency from the clearing of the **SRUSB** bit to when the peripheral is ready for use. Software can check the corresponding **PRUSB** bit to be sure.

Important: This register should be used to reset the USB module. To support legacy software, the **SRCR2** register is available. Setting the **USB0** bit in the **SRCR2** register also resets the USB module. If the **USB0** bit is set by writing to the **SRCR2** register, it can be read back correctly when reading the **SRCR2** register. If software uses this register to reset the USB module, the write causes proper operation, but the value of the **USB0** bit is not reflected in the **SRCR2** register. If software uses both legacy and peripheral-specific register accesses, the peripheral-specific registers must be accessed by read-modify-write operations that affect only peripherals that are not present in the legacy registers. In this manner, both the peripheral-specific and legacy registers have coherent information.

Universal Serial Bus Software Reset (SRUSB)

Base 0x400F.E000
Offset 0x528
Type R/W, reset 0x0000.0000

	31	30	29	28	27	26	25	24	23	22	21	20	19	18	17	16
	reserved															
Type	RO	RO	RO	RO	RO	RO	RO	RO	RO	RO	RO	RO	RO	RO	RO	RO
Reset	0	0	0	0	0	0	0	0	0	0	0	0	0	0	0	0
	15	14	13	12	11	10	9	8	7	6	5	4	3	2	1	0
	reserved															RO
Type	RO	RO	RO	RO	RO	RO	RO	RO	RO	RO	RO	RO	RO	RO	RO	R/W
Reset	0	0	0	0	0	0	0	0	0	0	0	0	0	0	0	0

Bit/Field	Name	Type	Reset	Description
31:1	reserved	RO	0	Software should not rely on the value of a reserved bit. To provide compatibility with future products, the value of a reserved bit should be preserved across a read-modify-write operation.
0	R0	R/W	0	USB Module Software Reset
	Value	Description		
	1	USB module is reset.		
	0	USB module is not reset.		

Register 42: Controller Area Network Software Reset (SRCAN), offset 0x534

The **SRCAN** register provides software the capability to reset the available CAN modules. This register provides the same capability as the legacy **Software Reset Control n SRCRn** registers specifically for the CAN modules and has the same bit polarity as the corresponding **SRCRn** bits.

A peripheral is reset by software using a simple two-step process:

1. Software sets a bit (or bits) in the **SRCAN** register. While the **SRCAN** bit is 1, the peripheral is held in reset.
2. Software completes the reset process by clearing the **SRCAN** bit.

There may be latency from the clearing of the **SRCAN** bit to when the peripheral is ready for use. Software can check the corresponding **PRCAN** bit to be sure.

Important: This register should be used to reset the CAN modules. To support legacy software, the **SRCR0** register is available. Setting a bit in the **SRCR0** register also resets the corresponding module. Any bits that are changed by writing to the **SRCR0** register can be read back correctly when reading the **SRCR0** register. If software uses this register to reset a legacy peripheral (such as CAN0), the write causes proper operation, but the value of that bit is not reflected in the **SRCR0** register. If software uses both legacy and peripheral-specific register accesses, the peripheral-specific registers must be accessed by read-modify-write operations that affect only peripherals that are not present in the legacy registers. In this manner, both the peripheral-specific and legacy registers have coherent information.

Controller Area Network Software Reset (SRCAN)

Base 0x400F.E000
 Offset 0x534
 Type R/W, reset 0x0000.0000

	31	30	29	28	27	26	25	24	23	22	21	20	19	18	17	16	
	reserved																
Type	RO	RO	RO	RO	RO	RO	RO	RO	RO	RO	RO	RO	RO	RO	RO	RO	
Reset	0	0	0	0	0	0	0	0	0	0	0	0	0	0	0	0	
	15	14	13	12	11	10	9	8	7	6	5	4	3	2	1	0	
	reserved															R1	R0
Type	RO	RO	RO	RO	RO	RO	RO	RO	RO	RO	RO	RO	RO	RO	RO	R/W	R/W
Reset	0	0	0	0	0	0	0	0	0	0	0	0	0	0	0	0	0

Bit/Field	Name	Type	Reset	Description
31:2	reserved	RO	0	Software should not rely on the value of a reserved bit. To provide compatibility with future products, the value of a reserved bit should be preserved across a read-modify-write operation.
1	R1	R/W	0	CAN Module 1 Software Reset
				Value Description
				1 CAN module 1 is reset.
				0 CAN module 1 is not reset.

Bit/Field	Name	Type	Reset	Description
0	R0	R/W	0	CAN Module 0 Software Reset
				Value Description
				1 CAN module 0 is reset.
				0 CAN module 0 is not reset.

Register 43: Analog-to-Digital Converter Software Reset (SRADC), offset 0x538

The **SRADC** register provides software the capability to reset the available ADC modules. This register provides the same capability as the legacy **Software Reset Control n SRCRn** registers specifically for the ADC modules and has the same bit polarity as the corresponding **SRCRn** bits.

A peripheral is reset by software using a simple two-step process:

1. Software sets a bit (or bits) in the **SRADC** register. While the **SRADC** bit is 1, the peripheral is held in reset.
2. Software completes the reset process by clearing the **SRADC** bit.

There may be latency from the clearing of the **SRADC** bit to when the peripheral is ready for use. Software can check the corresponding **PRADC** bit to be sure.

Important: This register should be used to reset the ADC modules. To support legacy software, the **SRCR0** register is available. Setting a bit in the **SRCR0** register also resets the corresponding module. Any bits that are changed by writing to the **SRCR0** register can be read back correctly when reading the **SRCR0** register. If software uses this register to reset a legacy peripheral (such as ADC0), the write causes proper operation, but the value of that bit is not reflected in the **SRCR0** register. If software uses both legacy and peripheral-specific register accesses, the peripheral-specific registers must be accessed by read-modify-write operations that affect only peripherals that are not present in the legacy registers. In this manner, both the peripheral-specific and legacy registers have coherent information.

Analog-to-Digital Converter Software Reset (SRADC)

Base 0x400F.E000
 Offset 0x538
 Type R/W, reset 0x0000.0000

	31	30	29	28	27	26	25	24	23	22	21	20	19	18	17	16	
	reserved																
Type	RO	RO	RO	RO	RO	RO	RO	RO	RO	RO	RO	RO	RO	RO	RO	RO	
Reset	0	0	0	0	0	0	0	0	0	0	0	0	0	0	0	0	
	15	14	13	12	11	10	9	8	7	6	5	4	3	2	1	0	
	reserved															R1	R0
Type	RO	RO	RO	RO	RO	RO	RO	RO	RO	RO	RO	RO	RO	RO	RO	R/W	R/W
Reset	0	0	0	0	0	0	0	0	0	0	0	0	0	0	0	0	0

Bit/Field	Name	Type	Reset	Description
31:2	reserved	RO	0	Software should not rely on the value of a reserved bit. To provide compatibility with future products, the value of a reserved bit should be preserved across a read-modify-write operation.
1	R1	R/W	0	ADC Module 1 Software Reset
				Value Description
				1 ADC module 1 is reset.
				0 ADC module 1 is not reset.

Bit/Field	Name	Type	Reset	Description
0	R0	R/W	0	ADC Module 0 Software Reset
				Value Description
				1 ADC module 0 is reset.
				0 ADC module 0 is not reset.

Register 44: Analog Comparator Software Reset (SRACMP), offset 0x53C

The **SRACMP** register provides software the capability to reset the available analog comparator module. This register provides the same capability as the legacy **Software Reset Control n SRCRn** registers specifically for the analog comparator module and has the same bit polarity as the corresponding **SRCRn** bits.

A block is reset by software using a simple two-step process:

1. Software sets a bit (or bits) in the **SRACMP** register. While the **SRACMP** bit is 1, the module is held in reset.
2. Software completes the reset process by clearing the **SRACMP** bit.

There may be latency from the clearing of the **SRACMP** bit to when the module is ready for use. Software can check the corresponding **PRACMP** bit to be sure.

Important: This register should be used to reset the analog comparator module. To support legacy software, the **SRCR1** register is available. Setting any of the **COMPn** bits in the **SRCR0** register also resets the analog comparator module. If any of the **COMPn** bits are set by writing to the **SRCR1** register, it can be read back correctly when reading the **SRCR0** register. If software uses this register to reset the analog comparator module, the write causes proper operation, but the value of **R0** is not reflected by the **COMPn** bits in the **SRCR1** register. If software uses both legacy and peripheral-specific register accesses, the peripheral-specific registers must be accessed by read-modify-write operations that affect only peripherals that are not present in the legacy registers. In this manner, both the peripheral-specific and legacy registers have coherent information.

Analog Comparator Software Reset (SRACMP)

Base 0x400F.E000
 Offset 0x53C
 Type R/W, reset 0x0000.0000

	31	30	29	28	27	26	25	24	23	22	21	20	19	18	17	16
	reserved															
Type	RO	RO	RO	RO	RO	RO	RO	RO	RO	RO	RO	RO	RO	RO	RO	RO
Reset	0	0	0	0	0	0	0	0	0	0	0	0	0	0	0	0
	15	14	13	12	11	10	9	8	7	6	5	4	3	2	1	0
	reserved															R0
Type	RO	RO	RO	RO	RO	RO	RO	RO	RO	RO	RO	RO	RO	RO	RO	R/W
Reset	0	0	0	0	0	0	0	0	0	0	0	0	0	0	0	0

Bit/Field	Name	Type	Reset	Description
31:1	reserved	RO	0	Software should not rely on the value of a reserved bit. To provide compatibility with future products, the value of a reserved bit should be preserved across a read-modify-write operation.
0	R0	R/W	0	Analog Comparator Module 0 Software Reset
	Value	Description		
	1	Analog comparator module is reset.		
	0	Analog comparator module is not reset.		

Register 45: Pulse Width Modulator Software Reset (SRPWM), offset 0x540

The **SRPWM** register provides software the capability to reset the available PWM modules. This register provides the same capability as the legacy **Software Reset Control n SRCRn** registers specifically for the PWM modules and has the same bit polarity as the corresponding **SRCRn** bits.

A peripheral is reset by software using a simple two-step process:

1. Software sets a bit (or bits) in the **SRPWM** register. While the **SRPWM** bit is 1, the peripheral is held in reset.
2. Software completes the reset process by clearing the **SRPWM** bit.

There may be latency from the clearing of the **SRPWM** bit to when the peripheral is ready for use. Software can check the corresponding **PRPWM** bit to be sure.

Important: This register should be used to reset the PWM modules. To support legacy software, the **SRCR0** register is available. Setting the **PWM** bit in the **SRCR0** register also resets the PWM0 module. If the **PWM** bit is changed by writing to the **SRCR0** register, it can be read back correctly when reading the **SRCR0** register. Software must use this register to reset PWM1, which is not present in the legacy registers. If software uses this register to reset PWM0, the write causes proper operation, but the value of that bit is not reflected in the **SRCR0** register. If software uses both legacy and peripheral-specific register accesses, the peripheral-specific registers must be accessed by read-modify-write operations that affect only peripherals that are not present in the legacy registers. In this manner, both the peripheral-specific and legacy registers have coherent information.

Pulse Width Modulator Software Reset (SRPWM)

Base 0x400F.E000

Offset 0x540

Type R/W, reset 0x0000.0000

	31	30	29	28	27	26	25	24	23	22	21	20	19	18	17	16	
	reserved																
Type	RO	RO	RO	RO	RO	RO	RO	RO	RO	RO	RO	RO	RO	RO	RO	RO	
Reset	0	0	0	0	0	0	0	0	0	0	0	0	0	0	0	0	
	15	14	13	12	11	10	9	8	7	6	5	4	3	2	1	0	
	reserved															R1	R0
Type	RO	RO	RO	RO	RO	RO	RO	RO	RO	RO	RO	RO	RO	RO	RO	R/W	R/W
Reset	0	0	0	0	0	0	0	0	0	0	0	0	0	0	0	0	0

Bit/Field	Name	Type	Reset	Description
31:2	reserved	RO	0	Software should not rely on the value of a reserved bit. To provide compatibility with future products, the value of a reserved bit should be preserved across a read-modify-write operation.
1	R1	R/W	0	PWM Module 1 Software Reset
				Value Description
			1	PWM module 1 is reset.
			0	PWM module 1 is not reset.

Bit/Field	Name	Type	Reset	Description
0	R0	R/W	0	PWM Module 0 Software Reset
				Value Description
				1 PWM module 0 is reset.
				0 PWM module 0 is not reset.

Register 46: Quadrature Encoder Interface Software Reset (SRQEI), offset 0x544

The **SRQEI** register provides software the capability to reset the available QEI modules. This register provides the same capability as the legacy **Software Reset Control n SRCRn** registers specifically for the QEI modules and has the same bit polarity as the corresponding **SRCRn** bits.

A peripheral is reset by software using a simple two-step process:

1. Software sets a bit (or bits) in the **SRQEI** register. While the **SRQEI** bit is 1, the peripheral is held in reset.
2. Software completes the reset process by clearing the **SRQEI** bit.

There may be latency from the clearing of the **SRQEI** bit to when the peripheral is ready for use. Software can check the corresponding **PRQEI** bit to be sure.

Important: This register should be used to reset the QEI modules. To support legacy software, the **SRCR1** register is available. Setting a bit in the **SRCR1** register also resets the corresponding module. Any bits that are changed by writing to the **SRCR1** register can be read back correctly when reading the **SRCR1** register. If software uses this register to reset a legacy peripheral (such as QEI0), the write causes proper operation, but the value of that bit is not reflected in the **SRCR1** register. If software uses both legacy and peripheral-specific register accesses, the peripheral-specific registers must be accessed by read-modify-write operations that affect only peripherals that are not present in the legacy registers. In this manner, both the peripheral-specific and legacy registers have coherent information.

Quadrature Encoder Interface Software Reset (SRQEI)

Base 0x400F.E000
Offset 0x544
Type R/W, reset 0x0000.0000

	31	30	29	28	27	26	25	24	23	22	21	20	19	18	17	16	
	reserved																
Type	RO	RO	RO	RO	RO	RO	RO	RO	RO	RO	RO	RO	RO	RO	RO	RO	
Reset	0	0	0	0	0	0	0	0	0	0	0	0	0	0	0	0	
	15	14	13	12	11	10	9	8	7	6	5	4	3	2	1	0	
	reserved															R1	R0
Type	RO	RO	RO	RO	RO	RO	RO	RO	RO	RO	RO	RO	RO	RO	R/W	R/W	
Reset	0	0	0	0	0	0	0	0	0	0	0	0	0	0	0	0	

Bit/Field	Name	Type	Reset	Description
31:2	reserved	RO	0	Software should not rely on the value of a reserved bit. To provide compatibility with future products, the value of a reserved bit should be preserved across a read-modify-write operation.
1	R1	R/W	0	QEI Module 1 Software Reset
				Value Description
			1	QEI module 1 is reset.
			0	QEI module 1 is not reset.

Bit/Field	Name	Type	Reset	Description
0	R0	R/W	0	QEI Module 0 Software Reset
				Value Description
				1 QEI module 0 is reset.
				0 QEI module 0 is not reset.

Register 47: EEPROM Software Reset (SREEPROM), offset 0x558

The **SREEPROM** register provides software the capability to reset the available EEPROM module.

A peripheral is reset by software using a simple two-step process:

1. Software sets a bit (or bits) in the **SREEPROM** register. While the **SREEPROM** bit is 1, the peripheral is held in reset.
2. Software completes the reset process by clearing the **SREEPROM** bit.

There may be latency from the clearing of the **SREEPROM** bit to when the peripheral is ready for use. Software can check the corresponding **PREEPROM** bit to be sure.

EEPROM Software Reset (SREEPROM)

Base 0x400F.E000

Offset 0x558

Type R/W, reset 0x0000.0000

	31	30	29	28	27	26	25	24	23	22	21	20	19	18	17	16
	reserved															
Type	RO	RO	RO	RO	RO	RO	RO	RO	RO	RO	RO	RO	RO	RO	RO	RO
Reset	0	0	0	0	0	0	0	0	0	0	0	0	0	0	0	0
	15	14	13	12	11	10	9	8	7	6	5	4	3	2	1	0
	reserved															RO
Type	RO	RO	RO	RO	RO	RO	RO	RO	RO	RO	RO	RO	RO	RO	RO	R/W
Reset	0	0	0	0	0	0	0	0	0	0	0	0	0	0	0	0

Bit/Field	Name	Type	Reset	Description
31:1	reserved	RO	0	Software should not rely on the value of a reserved bit. To provide compatibility with future products, the value of a reserved bit should be preserved across a read-modify-write operation.
0	R0	R/W	0	EEPROM Module Software Reset
				Value Description
				1 EEPROM module is reset.
				0 EEPROM module is not reset.

Register 48: 32/64-Bit Wide General-Purpose Timer Software Reset (SRWTIMER), offset 0x55C

The **SRWTIMER** register provides software the capability to reset the available 32/64-bit wide timer modules.

A peripheral is reset by software using a simple two-step process:

1. Software sets a bit (or bits) in the **SRWTIMER** register. While the **SRWTIMER** bit is 1, the peripheral is held in reset.
2. Software completes the reset process by clearing the **SRWTIMER** bit.

There may be latency from the clearing of the **SRWTIMER** bit to when the peripheral is ready for use. Software can check the corresponding **PRWTIMER** bit to be sure.

32/64-Bit Wide General-Purpose Timer Software Reset (SRWTIMER)

Base 0x400F.E000
 Offset 0x55C
 Type R/W, reset 0x0000.0000

	31	30	29	28	27	26	25	24	23	22	21	20	19	18	17	16	
	reserved																
Type	RO	RO	RO	RO	RO	RO	RO	RO	RO	RO	RO	RO	RO	RO	RO	RO	
Reset	0	0	0	0	0	0	0	0	0	0	0	0	0	0	0	0	
	15	14	13	12	11	10	9	8	7	6	5	4	3	2	1	0	
	reserved											R5	R4	R3	R2	R1	R0
Type	RO	RO	RO	RO	RO	RO	RO	RO	RO	RO	R/W	R/W	R/W	R/W	R/W	R/W	
Reset	0	0	0	0	0	0	0	0	0	0	0	0	0	0	0	0	

Bit/Field	Name	Type	Reset	Description
31:6	reserved	RO	0	Software should not rely on the value of a reserved bit. To provide compatibility with future products, the value of a reserved bit should be preserved across a read-modify-write operation.
5	R5	R/W	0	32/64-Bit Wide General-Purpose Timer 5 Software Reset Value Description 1 32/64-bit wide general-purpose timer module 5 is reset. 0 32/64-bit wide general-purpose timer module 5 is not reset.
4	R4	R/W	0	32/64-Bit Wide General-Purpose Timer 4 Software Reset Value Description 1 32/64-bit wide general-purpose timer module 4 is reset. 0 32/64-bit wide general-purpose timer module 4 is not reset.
3	R3	R/W	0	32/64-Bit Wide General-Purpose Timer 3 Software Reset Value Description 1 32/64-bit wide general-purpose timer module 3 is reset. 0 32/64-bit wide general-purpose timer module 3 is not reset.

Bit/Field	Name	Type	Reset	Description
2	R2	R/W	0	32/64-Bit Wide General-Purpose Timer 2 Software Reset Value Description 1 32/64-bit wide general-purpose timer module 2 is reset. 0 32/64-bit wide general-purpose timer module 2 is not reset.
1	R1	R/W	0	32/64-Bit Wide General-Purpose Timer 1 Software Reset Value Description 1 32/64-bit wide general-purpose timer module 1 is reset. 0 32/64-bit wide general-purpose timer module 1 is not reset.
0	R0	R/W	0	32/64-Bit Wide General-Purpose Timer 0 Software Reset Value Description 1 32/64-bit wide general-purpose timer module 0 is reset. 0 32/64-bit wide general-purpose timer module 0 is not reset.

Register 49: Watchdog Timer Run Mode Clock Gating Control (RCGCWD), offset 0x600

The **RCGCWD** register provides software the capability to enable and disable watchdog modules in Run mode. When enabled, a module is provided a clock and accesses to module registers are allowed. When disabled, the clock is disabled to save power and accesses to module registers generate a bus fault. This register provides the same capability as the legacy **Run Mode Clock Gating Control Register n RCGCn** registers specifically for the watchdog modules and has the same bit polarity as the corresponding **RCGCn** bits.

Important: This register should be used to control the clocking for the watchdog modules. To support legacy software, the **RCGC0** register is available. A write to the **RCGC0** register also writes the corresponding bit in this register. Any bits that are changed by writing to the **RCGC0** register can be read back correctly with a read of the **RCGC0** register. If software uses this register to write a legacy peripheral (such as Watchdog 0), the write causes proper operation, but the value of that bit is not reflected in the **RCGC0** register. If software uses both legacy and peripheral-specific register accesses, the peripheral-specific registers must be accessed by read-modify-write operations that affect only peripherals that are not present in the legacy registers. In this manner, both the peripheral-specific and legacy registers have coherent information.

Watchdog Timer Run Mode Clock Gating Control (RCGCWD)

Base 0x400F.E000
 Offset 0x600
 Type R/W, reset 0x0000.0000

	31	30	29	28	27	26	25	24	23	22	21	20	19	18	17	16	
	reserved																
Type	RO	RO	RO	RO	RO	RO	RO	RO	RO	RO	RO	RO	RO	RO	RO	RO	
Reset	0	0	0	0	0	0	0	0	0	0	0	0	0	0	0	0	
	15	14	13	12	11	10	9	8	7	6	5	4	3	2	1	0	
	reserved															R1	R0
Type	RO	RO	RO	RO	RO	RO	RO	RO	RO	RO	RO	RO	RO	RO	R/W	R/W	
Reset	0	0	0	0	0	0	0	0	0	0	0	0	0	0	0	0	

Bit/Field	Name	Type	Reset	Description
31:2	reserved	RO	0	Software should not rely on the value of a reserved bit. To provide compatibility with future products, the value of a reserved bit should be preserved across a read-modify-write operation.
1	R1	R/W	0	Watchdog Timer 1 Run Mode Clock Gating Control Value Description 1 Enable and provide a clock to Watchdog module 1 in Run mode. 0 Watchdog module 1 is disabled.
0	R0	R/W	0	Watchdog Timer 0 Run Mode Clock Gating Control Value Description 1 Enable and provide a clock to Watchdog module 0 in Run mode. 0 Watchdog module 0 is disabled.

Register 50: 16/32-Bit General-Purpose Timer Run Mode Clock Gating Control (RCGCTIMER), offset 0x604

The **RCGCTIMER** register provides software the capability to enable and disable 16/32-bit timer modules in Run mode. When enabled, a module is provided a clock and accesses to module registers are allowed. When disabled, the clock is disabled to save power and accesses to module registers generate a bus fault. This register provides the same capability as the legacy **Run Mode Clock Gating Control Register n RCGCn** registers specifically for the timer modules and has the same bit polarity as the corresponding **RCGCn** bits.

Important: This register should be used to control the clocking for the timer modules. To support legacy software, the **RCGC1** register is available. A write to the **RCGC1** register also writes the corresponding bit in this register. Any bits that are changed by writing to the **RCGC1** register can be read back correctly with a read of the **RCGC1** register. Software must use this register to support modules that are not present in the legacy registers. If software uses this register to write a legacy peripheral (such as Timer 0), the write causes proper operation, but the value of that bit is not reflected in the **RCGC1** register. If software uses both legacy and peripheral-specific register accesses, the peripheral-specific registers must be accessed by read-modify-write operations that affect only peripherals that are not present in the legacy registers. In this manner, both the peripheral-specific and legacy registers have coherent information.

16/32-Bit General-Purpose Timer Run Mode Clock Gating Control (RCGCTIMER)

Base 0x400F.E000
Offset 0x604
Type R/W, reset 0x0000.0000

	31	30	29	28	27	26	25	24	23	22	21	20	19	18	17	16
	reserved															
Type	RO	RO	RO	RO	RO	RO	RO	RO	RO	RO	RO	RO	RO	RO	RO	RO
Reset	0	0	0	0	0	0	0	0	0	0	0	0	0	0	0	0
	15	14	13	12	11	10	9	8	7	6	5	4	3	2	1	0
	reserved										R5	R4	R3	R2	R1	R0
Type	RO	RO	RO	RO	RO	RO	RO	RO	RO	RO	R/W	R/W	R/W	R/W	R/W	R/W
Reset	0	0	0	0	0	0	0	0	0	0	0	0	0	0	0	0

Bit/Field	Name	Type	Reset	Description
31:6	reserved	RO	0	Software should not rely on the value of a reserved bit. To provide compatibility with future products, the value of a reserved bit should be preserved across a read-modify-write operation.
5	R5	R/W	0	16/32-Bit General-Purpose Timer 5 Run Mode Clock Gating Control
				Value Description
				1 Enable and provide a clock to 16/32-bit general-purpose timer module 5 in Run mode.
				0 16/32-bit general-purpose timer module 5 is disabled.

Bit/Field	Name	Type	Reset	Description
4	R4	R/W	0	<p>16/32-Bit General-Purpose Timer 4 Run Mode Clock Gating Control</p> <p>Value Description</p> <p>1 Enable and provide a clock to 16/32-bit general-purpose timer module 4 in Run mode.</p> <p>0 16/32-bit general-purpose timer module 4 is disabled.</p>
3	R3	R/W	0	<p>16/32-Bit General-Purpose Timer 3 Run Mode Clock Gating Control</p> <p>Value Description</p> <p>1 Enable and provide a clock to 16/32-bit general-purpose timer module 3 in Run mode.</p> <p>0 16/32-bit general-purpose timer module 3 is disabled.</p>
2	R2	R/W	0	<p>16/32-Bit General-Purpose Timer 2 Run Mode Clock Gating Control</p> <p>Value Description</p> <p>1 Enable and provide a clock to 16/32-bit general-purpose timer module 2 in Run mode.</p> <p>0 16/32-bit general-purpose timer module 2 is disabled.</p>
1	R1	R/W	0	<p>16/32-Bit General-Purpose Timer 1 Run Mode Clock Gating Control</p> <p>Value Description</p> <p>1 Enable and provide a clock to 16/32-bit general-purpose timer module 1 in Run mode.</p> <p>0 16/32-bit general-purpose timer module 1 is disabled.</p>
0	R0	R/W	0	<p>16/32-Bit General-Purpose Timer 0 Run Mode Clock Gating Control</p> <p>Value Description</p> <p>1 Enable and provide a clock to 16/32-bit general-purpose timer module 0 in Run mode.</p> <p>0 16/32-bit general-purpose timer module 0 is disabled.</p>

Register 51: General-Purpose Input/Output Run Mode Clock Gating Control (RCGCGPIO), offset 0x608

The **RCGCGPIO** register provides software the capability to enable and disable GPIO modules in Run mode. When enabled, a module is provided a clock and accesses to module registers are allowed. When disabled, the clock is disabled to save power and accesses to module registers generate a bus fault. This register provides the same capability as the legacy **Run Mode Clock Gating Control Register n RCGCn** registers specifically for the watchdog modules and has the same bit polarity as the corresponding **RCGCn** bits.

Important: This register should be used to control the clocking for the GPIO modules. To support legacy software, the **RCGC2** register is available. A write to the **RCGC2** register also writes the corresponding bit in this register. Any bits that are changed by writing to the **RCGC2** register can be read back correctly with a read of the **RCGC2** register. Software must use this register to support modules that are not present in the legacy registers. If software uses this register to write a legacy peripheral (such as GPIO A), the write causes proper operation, but the value of that bit is not reflected in the **RCGC2** register. If software uses both legacy and peripheral-specific register accesses, the peripheral-specific registers must be accessed by read-modify-write operations that affect only peripherals that are not present in the legacy registers. In this manner, both the peripheral-specific and legacy registers have coherent information.

General-Purpose Input/Output Run Mode Clock Gating Control (RCGCGPIO)

Base 0x400F.E000
Offset 0x608
Type R/W, reset 0x0000.0000

	31	30	29	28	27	26	25	24	23	22	21	20	19	18	17	16	
	reserved																
Type	RO	RO	RO	RO	RO	RO	RO	RO	RO	RO	RO	RO	RO	RO	RO	RO	
Reset	0	0	0	0	0	0	0	0	0	0	0	0	0	0	0	0	
	15	14	13	12	11	10	9	8	7	6	5	4	3	2	1	0	
	reserved										R6	R5	R4	R3	R2	R1	R0
Type	RO	RO	RO	RO	RO	RO	RO	RO	RO	RO	R/W	R/W	R/W	R/W	R/W	R/W	
Reset	0	0	0	0	0	0	0	0	0	0	0	0	0	0	0	0	

Bit/Field	Name	Type	Reset	Description
31:7	reserved	RO	0	Software should not rely on the value of a reserved bit. To provide compatibility with future products, the value of a reserved bit should be preserved across a read-modify-write operation.
6	R6	R/W	0	GPIO Port G Run Mode Clock Gating Control Value Description 1 Enable and provide a clock to GPIO Port G in Run mode. 0 GPIO Port G is disabled.
5	R5	R/W	0	GPIO Port F Run Mode Clock Gating Control Value Description 1 Enable and provide a clock to GPIO Port F in Run mode. 0 GPIO Port F is disabled.

Bit/Field	Name	Type	Reset	Description
4	R4	R/W	0	GPIO Port E Run Mode Clock Gating Control Value Description 1 Enable and provide a clock to GPIO Port E in Run mode. 0 GPIO Port E is disabled.
3	R3	R/W	0	GPIO Port D Run Mode Clock Gating Control Value Description 1 Enable and provide a clock to GPIO Port D in Run mode. 0 GPIO Port D is disabled.
2	R2	R/W	0	GPIO Port C Run Mode Clock Gating Control Value Description 1 Enable and provide a clock to GPIO Port C in Run mode. 0 GPIO Port C is disabled.
1	R1	R/W	0	GPIO Port B Run Mode Clock Gating Control Value Description 1 Enable and provide a clock to GPIO Port B in Run mode. 0 GPIO Port B is disabled.
0	R0	R/W	0	GPIO Port A Run Mode Clock Gating Control Value Description 1 Enable and provide a clock to GPIO Port A in Run mode. 0 GPIO Port A is disabled.

Register 52: Micro Direct Memory Access Run Mode Clock Gating Control (RCGCDMA), offset 0x60C

The **RCGCDMA** register provides software the capability to enable and disable the μ DMA module in Run mode. When enabled, the module is provided a clock and accesses to module registers are allowed. When disabled, the clock is disabled to save power and accesses to module registers generate a bus fault. This register provides the same capability as the legacy **Run Mode Clock Gating Control Register n RCGCn** registers specifically for the watchdog modules and has the same bit polarity as the corresponding **RCGCn** bits.

Important: This register should be used to control the clocking for the μ DMA module. To support legacy software, the **RCGC2** register is available. A write to the **UDMA** bit in the **RCGC2** register also writes the **R0** bit in this register. If the **UDMA** bit is changed by writing to the **RCGC2** register, it can be read back correctly with a read of the **RCGC2** register. If software uses this register to control the clock for the μ DMA module, the write causes proper operation, but the **UDMA** bit in the **RCGC2** register does not reflect the value of the **R0** bit. If software uses both legacy and peripheral-specific register accesses, the peripheral-specific registers must be accessed by read-modify-write operations that affect only peripherals that are not present in the legacy registers. In this manner, both the peripheral-specific and legacy registers have coherent information.

Micro Direct Memory Access Run Mode Clock Gating Control (RCGCDMA)

Base 0x400F.E000
Offset 0x60C
Type R/W, reset 0x0000.0000

	31	30	29	28	27	26	25	24	23	22	21	20	19	18	17	16
	reserved															
Type	RO	RO	RO	RO	RO	RO	RO	RO	RO	RO	RO	RO	RO	RO	RO	RO
Reset	0	0	0	0	0	0	0	0	0	0	0	0	0	0	0	0
	15	14	13	12	11	10	9	8	7	6	5	4	3	2	1	0
	reserved															
																R0
Type	RO	RO	RO	RO	RO	RO	RO	RO	RO	RO	RO	RO	RO	RO	RO	R/W
Reset	0	0	0	0	0	0	0	0	0	0	0	0	0	0	0	0

Bit/Field	Name	Type	Reset	Description
31:1	reserved	RO	0	Software should not rely on the value of a reserved bit. To provide compatibility with future products, the value of a reserved bit should be preserved across a read-modify-write operation.

0	R0	R/W	0	μ DMA Module Run Mode Clock Gating Control
---	----	-----	---	--

Value Description

1	Enable and provide a clock to the μ DMA module in Run mode.
0	μ DMA module is disabled.

Register 53: Universal Asynchronous Receiver/Transmitter Run Mode Clock Gating Control (RCGCUART), offset 0x618

The **RCGCUART** register provides software the capability to enable and disable the UART modules in Run mode. When enabled, a module is provided a clock and accesses to module registers are allowed. When disabled, the clock is disabled to save power and accesses to module registers generate a bus fault. This register provides the same capability as the legacy **Run Mode Clock Gating Control Register n RCGCn** registers specifically for the watchdog modules and has the same bit polarity as the corresponding **RCGCn** bits.

Important: This register should be used to control the clocking for the UART modules. To support legacy software, the **RCGC1** register is available. A write to the **RCGC1** register also writes the corresponding bit in this register. Any bits that are changed by writing to the **RCGC1** register can be read back correctly with a read of the **RCGC1** register. Software must use this register to support modules that are not present in the legacy registers. If software uses this register to write a legacy peripheral (such as UART0), the write causes proper operation, but the value of that bit is not reflected in the **RCGC1** register. If software uses both legacy and peripheral-specific register accesses, the peripheral-specific registers must be accessed by read-modify-write operations that affect only peripherals that are not present in the legacy registers. In this manner, both the peripheral-specific and legacy registers have coherent information.

Universal Asynchronous Receiver/Transmitter Run Mode Clock Gating Control (RCGCUART)

Base 0x400F.E000
 Offset 0x618
 Type R/W, reset 0x0000.0000

	31	30	29	28	27	26	25	24	23	22	21	20	19	18	17	16
	reserved															
Type	RO	RO	RO	RO	RO	RO	RO	RO	RO	RO	RO	RO	RO	RO	RO	RO
Reset	0	0	0	0	0	0	0	0	0	0	0	0	0	0	0	0
	15	14	13	12	11	10	9	8	7	6	5	4	3	2	1	0
	reserved								R7	R6	R5	R4	R3	R2	R1	R0
Type	RO	RO	RO	RO	RO	RO	RO	RO	R/W	R/W	R/W	R/W	R/W	R/W	R/W	R/W
Reset	0	0	0	0	0	0	0	0	0	0	0	0	0	0	0	0

Bit/Field	Name	Type	Reset	Description
31:8	reserved	RO	0	Software should not rely on the value of a reserved bit. To provide compatibility with future products, the value of a reserved bit should be preserved across a read-modify-write operation.
7	R7	R/W	0	UART Module 7 Run Mode Clock Gating Control Value Description 1 Enable and provide a clock to UART module 7 in Run mode. 0 UART module 7 is disabled.
6	R6	R/W	0	UART Module 6 Run Mode Clock Gating Control Value Description 1 Enable and provide a clock to UART module 6 in Run mode. 0 UART module 6 is disabled.

Bit/Field	Name	Type	Reset	Description
5	R5	R/W	0	UART Module 5 Run Mode Clock Gating Control Value Description 1 Enable and provide a clock to UART module 5 in Run mode. 0 UART module 5 is disabled.
4	R4	R/W	0	UART Module 4 Run Mode Clock Gating Control Value Description 1 Enable and provide a clock to UART module 4 in Run mode. 0 UART module 4 is disabled.
3	R3	R/W	0	UART Module 3 Run Mode Clock Gating Control Value Description 1 Enable and provide a clock to UART module 3 in Run mode. 0 UART module 3 is disabled.
2	R2	R/W	0	UART Module 2 Run Mode Clock Gating Control Value Description 1 Enable and provide a clock to UART module 2 in Run mode. 0 UART module 2 is disabled.
1	R1	R/W	0	UART Module 1 Run Mode Clock Gating Control Value Description 1 Enable and provide a clock to UART module 1 in Run mode. 0 UART module 1 is disabled.
0	R0	R/W	0	UART Module 0 Run Mode Clock Gating Control Value Description 1 Enable and provide a clock to UART module 0 in Run mode. 0 UART module 0 is disabled.

Register 54: Synchronous Serial Interface Run Mode Clock Gating Control (RCGCSSI), offset 0x61C

The **RCGCSSI** register provides software the capability to enable and disable the SSI modules in Run mode. When enabled, a module is provided a clock and accesses to module registers are allowed. When disabled, the clock is disabled to save power and accesses to module registers generate a bus fault. This register provides the same capability as the legacy **Run Mode Clock Gating Control Register n RCGCn** registers specifically for the watchdog modules and has the same bit polarity as the corresponding **RCGCn** bits.

Important: This register should be used to control the clocking for the SSI modules. To support legacy software, the **RCGC1** register is available. A write to the **RCGC1** register also writes the corresponding bit in this register. Any bits that are changed by writing to the **RCGC1** register can be read back correctly with a read of the **RCGC1** register. Software must use this register to support modules that are not present in the legacy registers. If software uses this register to write a legacy peripheral (such as SSI0), the write causes proper operation, but the value of that bit is not reflected in the **RCGC1** register. If software uses both legacy and peripheral-specific register accesses, the peripheral-specific registers must be accessed by read-modify-write operations that affect only peripherals that are not present in the legacy registers. In this manner, both the peripheral-specific and legacy registers have coherent information.

Synchronous Serial Interface Run Mode Clock Gating Control (RCGCSSI)

Base 0x400F.E000
 Offset 0x61C
 Type R/W, reset 0x0000.0000

	31	30	29	28	27	26	25	24	23	22	21	20	19	18	17	16	
	reserved																
Type	RO	RO	RO	RO	RO	RO	RO	RO	RO	RO	RO	RO	RO	RO	RO	RO	
Reset	0	0	0	0	0	0	0	0	0	0	0	0	0	0	0	0	
	15	14	13	12	11	10	9	8	7	6	5	4	3	2	1	0	
	reserved													R3	R2	R1	R0
Type	RO	RO	RO	RO	RO	RO	RO	RO	RO	RO	RO	RO	RO	R/W	R/W	R/W	R/W
Reset	0	0	0	0	0	0	0	0	0	0	0	0	0	0	0	0	0

Bit/Field	Name	Type	Reset	Description
31:4	reserved	RO	0	Software should not rely on the value of a reserved bit. To provide compatibility with future products, the value of a reserved bit should be preserved across a read-modify-write operation.
3	R3	R/W	0	SSI Module 3 Run Mode Clock Gating Control
				Value Description
				1 Enable and provide a clock to SSI module 3 in Run mode.
				0 SSI module 3 is disabled.
2	R2	R/W	0	SSI Module 2 Run Mode Clock Gating Control
				Value Description
				1 Enable and provide a clock to SSI module 2 in Run mode.
				0 SSI module 2 is disabled.

Bit/Field	Name	Type	Reset	Description
1	R1	R/W	0	SSI Module 1 Run Mode Clock Gating Control Value Description 1 Enable and provide a clock to SSI module 1 in Run mode. 0 SSI module 1 is disabled.
0	R0	R/W	0	SSI Module 0 Run Mode Clock Gating Control Value Description 1 Enable and provide a clock to SSI module 0 in Run mode. 0 SSI module 0 is disabled.

Register 55: Inter-Integrated Circuit Run Mode Clock Gating Control (RCGCI2C), offset 0x620

The **RCGCI2C** register provides software the capability to enable and disable the I²C modules in Run mode. When enabled, a module is provided a clock and accesses to module registers are allowed. When disabled, the clock is disabled to save power and accesses to module registers generate a bus fault. This register provides the same capability as the legacy **Run Mode Clock Gating Control Register n RCGCn** registers specifically for the watchdog modules and has the same bit polarity as the corresponding **RCGCn** bits.

Important: This register should be used to control the clocking for the I²C modules. To support legacy software, the **RCGC1** register is available. A write to the **RCGC1** register also writes the corresponding bit in this register. Any bits that are changed by writing to the **RCGC1** register can be read back correctly with a read of the **RCGC1** register. Software must use this register to support modules that are not present in the legacy registers. If software uses this register to write a legacy peripheral (such as I2C0), the write causes proper operation, but the value of that bit is not reflected in the **RCGC1** register. If software uses both legacy and peripheral-specific register accesses, the peripheral-specific registers must be accessed by read-modify-write operations that affect only peripherals that are not present in the legacy registers. In this manner, both the peripheral-specific and legacy registers have coherent information.

Inter-Integrated Circuit Run Mode Clock Gating Control (RCGCI2C)

Base 0x400F.E000
 Offset 0x620
 Type R/W, reset 0x0000.0000

	31	30	29	28	27	26	25	24	23	22	21	20	19	18	17	16	
	reserved																
Type	RO	RO	RO	RO	RO	RO	RO	RO	RO	RO	RO	RO	RO	RO	RO	RO	
Reset	0	0	0	0	0	0	0	0	0	0	0	0	0	0	0	0	
	15	14	13	12	11	10	9	8	7	6	5	4	3	2	1	0	
	reserved											R5	R4	R3	R2	R1	R0
Type	RO	RO	RO	RO	RO	RO	RO	RO	RO	RO	R/W	R/W	R/W	R/W	R/W	R/W	
Reset	0	0	0	0	0	0	0	0	0	0	0	0	0	0	0	0	

Bit/Field	Name	Type	Reset	Description
31:6	reserved	RO	0	Software should not rely on the value of a reserved bit. To provide compatibility with future products, the value of a reserved bit should be preserved across a read-modify-write operation.
5	R5	R/W	0	I ² C Module 5 Run Mode Clock Gating Control Value Description 1 Enable and provide a clock to I ² C module 5 in Run mode. 0 I ² C module 5 is disabled.
4	R4	R/W	0	I ² C Module 4 Run Mode Clock Gating Control Value Description 1 Enable and provide a clock to I ² C module 4 in Run mode. 0 I ² C module 4 is disabled.

Bit/Field	Name	Type	Reset	Description
3	R3	R/W	0	I ² C Module 3 Run Mode Clock Gating Control Value Description 1 Enable and provide a clock to I ² C module 3 in Run mode. 0 I ² C module 3 is disabled.
2	R2	R/W	0	I ² C Module 2 Run Mode Clock Gating Control Value Description 1 Enable and provide a clock to I ² C module 2 in Run mode. 0 I ² C module 2 is disabled.
1	R1	R/W	0	I ² C Module 1 Run Mode Clock Gating Control Value Description 1 Enable and provide a clock to I ² C module 1 in Run mode. 0 I ² C module 1 is disabled.
0	R0	R/W	0	I ² C Module 0 Run Mode Clock Gating Control Value Description 1 Enable and provide a clock to I ² C module 0 in Run mode. 0 I ² C module 0 is disabled.

Register 56: Universal Serial Bus Run Mode Clock Gating Control (RCGCUSB), offset 0x628

The **RCGCUSB** register provides software the capability to enable and disable the USB module in Run mode. When enabled, the module is provided a clock and accesses to module registers are allowed. When disabled, the clock is disabled to save power and accesses to module registers generate a bus fault. This register provides the same capability as the legacy **Run Mode Clock Gating Control Register n RCGCn** registers specifically for the watchdog modules and has the same bit polarity as the corresponding **RCGCn** bits.

Important: This register should be used to control the clocking for the USB module. To support legacy software, the **RCGC2** register is available. A write to the **USB0** bit in the **RCGC2** register also writes the **R0** bit in this register. If the **USB0** bit is changed by writing to the **RCGC2** register, it can be read back correctly with a read of the **RCGC2** register. If software uses this register to control the clock for the USB module, the write causes proper operation, but the **USB0** bit in the **RCGC2** register does not reflect the value of the **R0** bit. If software uses both legacy and peripheral-specific register accesses, the peripheral-specific registers must be accessed by read-modify-write operations that affect only peripherals that are not present in the legacy registers. In this manner, both the peripheral-specific and legacy registers have coherent information.

Universal Serial Bus Run Mode Clock Gating Control (RCGCUSB)

Base 0x400F.E000
 Offset 0x628
 Type R/W, reset 0x0000.0000

	31	30	29	28	27	26	25	24	23	22	21	20	19	18	17	16
	reserved															
Type	RO	RO	RO	RO	RO	RO	RO	RO	RO	RO	RO	RO	RO	RO	RO	RO
Reset	0	0	0	0	0	0	0	0	0	0	0	0	0	0	0	0
	15	14	13	12	11	10	9	8	7	6	5	4	3	2	1	0
	reserved															R0
Type	RO	RO	RO	RO	RO	RO	RO	RO	RO	RO	RO	RO	RO	RO	RO	R/W
Reset	0	0	0	0	0	0	0	0	0	0	0	0	0	0	0	0

Bit/Field	Name	Type	Reset	Description
31:1	reserved	RO	0	Software should not rely on the value of a reserved bit. To provide compatibility with future products, the value of a reserved bit should be preserved across a read-modify-write operation.
0	R0	R/W	0	USB Module Run Mode Clock Gating Control
				Value Description
				1 Enable and provide a clock to the USB module in Run mode.
				0 USB module is disabled.

Register 57: Controller Area Network Run Mode Clock Gating Control (RCGCCAN), offset 0x634

The **RCGCCAN** register provides software the capability to enable and disable the CAN modules in Run mode. When enabled, a module is provided a clock and accesses to module registers are allowed. When disabled, the clock is disabled to save power and accesses to module registers generate a bus fault. This register provides the same capability as the legacy **Run Mode Clock Gating Control Register n RCGCn** registers specifically for the watchdog modules and has the same bit polarity as the corresponding **RCGCn** bits.

Important: This register should be used to control the clocking for the CAN modules. To support legacy software, the RCGC0 register is available. A write to the RCGC0 register also writes the corresponding bit in this register. Any bits that are changed by writing to the RCGC0 register can be read back correctly with a read of the RCGC0 register. If software uses this register to write a legacy peripheral (such as CAN0), the write causes proper operation, but the value of that bit is not reflected in the RCGC0 register. If software uses both legacy and peripheral-specific register accesses, the peripheral-specific registers must be accessed by read-modify-write operations that affect only peripherals that are not present in the legacy registers. In this manner, both the peripheral-specific and legacy registers have coherent information.

Controller Area Network Run Mode Clock Gating Control (RCGCCAN)

Base 0x400F.E000
Offset 0x634
Type R/W, reset 0x0000.0000

	31	30	29	28	27	26	25	24	23	22	21	20	19	18	17	16	
	reserved																
Type	RO	RO	RO	RO	RO	RO	RO	RO	RO	RO	RO	RO	RO	RO	RO	RO	
Reset	0	0	0	0	0	0	0	0	0	0	0	0	0	0	0	0	
	15	14	13	12	11	10	9	8	7	6	5	4	3	2	1	0	
	reserved															R1	R0
Type	RO	RO	RO	RO	RO	RO	RO	RO	RO	RO	RO	RO	RO	RO	R/W	R/W	
Reset	0	0	0	0	0	0	0	0	0	0	0	0	0	0	0	0	

Bit/Field	Name	Type	Reset	Description
31:2	reserved	RO	0	Software should not rely on the value of a reserved bit. To provide compatibility with future products, the value of a reserved bit should be preserved across a read-modify-write operation.
1	R1	R/W	0	CAN Module 1 Run Mode Clock Gating Control Value Description 1 Enable and provide a clock to CAN module 1 in Run mode. 0 CAN module 1 is disabled.
0	R0	R/W	0	CAN Module 0 Run Mode Clock Gating Control Value Description 1 Enable and provide a clock to CAN module 0 in Run mode. 0 CAN module 0 is disabled.

Register 58: Analog-to-Digital Converter Run Mode Clock Gating Control (RCGCADC), offset 0x638

The **RCGCADC** register provides software the capability to enable and disable the ADC modules in Run mode. When enabled, a module is provided a clock and accesses to module registers are allowed. When disabled, the clock is disabled to save power and accesses to module registers generate a bus fault. This register provides the same capability as the legacy **Run Mode Clock Gating Control Register n RCGCn** registers specifically for the watchdog modules and has the same bit polarity as the corresponding **RCGCn** bits.

Important: This register should be used to control the clocking for the ADC modules. To support legacy software, the RCGC0 register is available. A write to the RCGC0 register also writes the corresponding bit in this register. Any bits that are changed by writing to the RCGC0 register can be read back correctly with a read of the RCGC0 register. If software uses this register to write a legacy peripheral (such as ADC0), the write causes proper operation, but the value of that bit is not reflected in the RCGC0 register. If software uses both legacy and peripheral-specific register accesses, the peripheral-specific registers must be accessed by read-modify-write operations that affect only peripherals that are not present in the legacy registers. In this manner, both the peripheral-specific and legacy registers have coherent information.

Analog-to-Digital Converter Run Mode Clock Gating Control (RCGCADC)

Base 0x400F.E000
 Offset 0x638
 Type R/W, reset 0x0000.0000

	31	30	29	28	27	26	25	24	23	22	21	20	19	18	17	16	
	reserved																
Type	RO	RO	RO	RO	RO	RO	RO	RO	RO	RO	RO	RO	RO	RO	RO	RO	
Reset	0	0	0	0	0	0	0	0	0	0	0	0	0	0	0	0	
	15	14	13	12	11	10	9	8	7	6	5	4	3	2	1	0	
	reserved															R1	R0
Type	RO	RO	RO	RO	RO	RO	RO	RO	RO	RO	RO	RO	RO	RO	R/W	R/W	
Reset	0	0	0	0	0	0	0	0	0	0	0	0	0	0	0	0	

Bit/Field	Name	Type	Reset	Description
31:2	reserved	RO	0	Software should not rely on the value of a reserved bit. To provide compatibility with future products, the value of a reserved bit should be preserved across a read-modify-write operation.
1	R1	R/W	0	ADC Module 1 Run Mode Clock Gating Control Value Description 1 Enable and provide a clock to ADC module 1 in Run mode. 0 ADC module 1 is disabled.
0	R0	R/W	0	ADC Module 0 Run Mode Clock Gating Control Value Description 1 Enable and provide a clock to ADC module 0 in Run mode. 0 ADC module 0 is disabled.

Register 59: Analog Comparator Run Mode Clock Gating Control (RCGCACMP), offset 0x63C

The **RCGCACMP** register provides software the capability to enable and disable the analog comparator module in Run mode. When enabled, the module is provided a clock and accesses to module registers are allowed. When disabled, the clock is disabled to save power and accesses to module registers generate a bus fault. This register provides the same capability as the legacy **Run Mode Clock Gating Control Register n RCGCn** registers specifically for the watchdog modules and has the same bit polarity as the corresponding **RCGCn** bits.

Important: This register should be used to control the clocking for the analog comparator module. To support legacy software, the RCGC1 register is available. Setting any of the **COMP_n** bits in the RCGC1 register also sets the **R0** bit in this register. If any of the **COMP_n** bits are set by writing to the RCGC1 register, it can be read back correctly when reading the RCGC1 register. If software uses this register to change the clocking for the analog comparator module, the write causes proper operation, but the value **R0** is not reflected by the **COMP_n** bits in the RCGC1 register. If software uses both legacy and peripheral-specific register accesses, the peripheral-specific registers must be accessed by read-modify-write operations that affect only peripherals that are not present in the legacy registers. In this manner, both the peripheral-specific and legacy registers have coherent information.

Analog Comparator Run Mode Clock Gating Control (RCGCACMP)

Base 0x400F.E000
Offset 0x63C
Type R/W, reset 0x0000.0000

	31	30	29	28	27	26	25	24	23	22	21	20	19	18	17	16
	reserved															
Type	RO	RO	RO	RO	RO	RO	RO	RO	RO	RO	RO	RO	RO	RO	RO	RO
Reset	0	0	0	0	0	0	0	0	0	0	0	0	0	0	0	0
	15	14	13	12	11	10	9	8	7	6	5	4	3	2	1	0
	reserved															
Type	RO	RO	RO	RO	RO	RO	RO	RO	RO	RO	RO	RO	RO	RO	RO	R/W
Reset	0	0	0	0	0	0	0	0	0	0	0	0	0	0	0	0

Bit/Field	Name	Type	Reset	Description
31:1	reserved	RO	0	Software should not rely on the value of a reserved bit. To provide compatibility with future products, the value of a reserved bit should be preserved across a read-modify-write operation.
0	R0	R/W	0	Analog Comparator Module 0 Run Mode Clock Gating Control
				Value Description
				1 Enable and provide a clock to the analog comparator module in Run mode.
				0 Analog comparator module is disabled.

Register 60: Pulse Width Modulator Run Mode Clock Gating Control (RCGCPWM), offset 0x640

The **RCGCPWM** register provides software the capability to enable and disable the PWM modules in Run mode. When enabled, a module is provided a clock and accesses to module registers are allowed. When disabled, the clock is disabled to save power and accesses to module registers generate a bus fault. This register provides the same capability as the legacy **Run Mode Clock Gating Control Register n RCGCn** registers specifically for the watchdog modules and has the same bit polarity as the corresponding **RCGCn** bits.

Important: This register should be used to control the clocking for the PWM modules. To support legacy software, the **RCGC0** register is available. A write to the **PWM** bit in the **RCGC0** register also writes the **R0** bit in this register. If the **PWM** bit is changed by writing to the **RCGC0** register, it can be read back correctly with a read of the **RCGC0** register. Software must use this register to support modules that are not present in the legacy registers. If software uses this register to write to **R0**, the write causes proper operation, but the value of that bit is not reflected in the **PWM** bit in the **RCGC0** register. If software uses both legacy and peripheral-specific register accesses, the peripheral-specific registers must be accessed by read-modify-write operations that affect only peripherals that are not present in the legacy registers. In this manner, both the peripheral-specific and legacy registers have coherent information.

Pulse Width Modulator Run Mode Clock Gating Control (RCGCPWM)

Base 0x400F.E000
 Offset 0x640
 Type R/W, reset 0x0000.0000

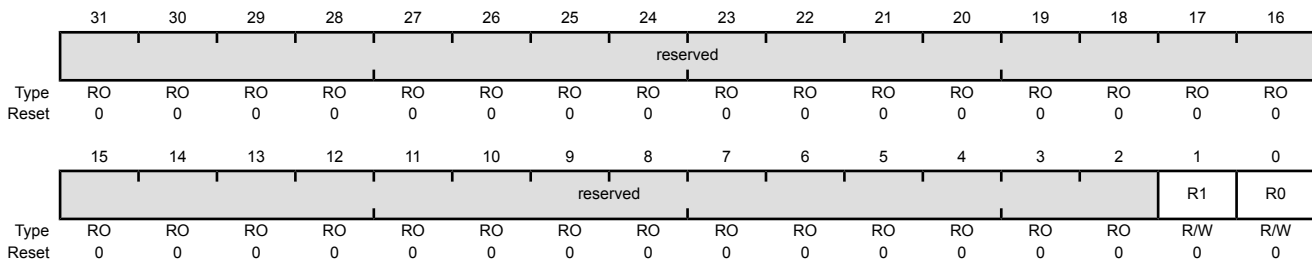

Bit/Field	Name	Type	Reset	Description
31:2	reserved	RO	0	Software should not rely on the value of a reserved bit. To provide compatibility with future products, the value of a reserved bit should be preserved across a read-modify-write operation.
1	R1	R/W	0	PWM Module 1 Run Mode Clock Gating Control Value Description 1 Enable and provide a clock to PWM module 1 in Run mode. 0 PWM module 1 is disabled.
0	R0	R/W	0	PWM Module 0 Run Mode Clock Gating Control Value Description 1 Enable and provide a clock to PWM module 0 in Run mode. 0 PWM module 0 is disabled.

Register 61: Quadrature Encoder Interface Run Mode Clock Gating Control (RCGCQEI), offset 0x644

The **RCGCQEI** register provides software the capability to enable and disable the QEI modules in Run mode. When enabled, a module is provided a clock and accesses to module registers are allowed. When disabled, the clock is disabled to save power and accesses to module registers generate a bus fault. This register provides the same capability as the legacy **Run Mode Clock Gating Control Register n RCGCn** registers specifically for the watchdog modules and has the same bit polarity as the corresponding **RCGCn** bits.

Important: This register should be used to control the clocking for the QEI modules. To support legacy software, the **RCGC1** register is available. A write to the **RCGC1** register also writes the corresponding bit in this register. Any bits that are changed by writing to the **RCGC1** register can be read back correctly with a read of the **RCGC1** register. If software uses this register to write a legacy peripheral (such as QEI0), the write causes proper operation, but the value of that bit is not reflected in the **RCGC1** register. If software uses both legacy and peripheral-specific register accesses, the peripheral-specific registers must be accessed by read-modify-write operations that affect only peripherals that are not present in the legacy registers. In this manner, both the peripheral-specific and legacy registers have coherent information.

Quadrature Encoder Interface Run Mode Clock Gating Control (RCGCQEI)

Base 0x400F.E000
Offset 0x644
Type R/W, reset 0x0000.0000

	31	30	29	28	27	26	25	24	23	22	21	20	19	18	17	16	
	reserved																
Type	RO	RO	RO	RO	RO	RO	RO	RO	RO	RO	RO	RO	RO	RO	RO	RO	
Reset	0	0	0	0	0	0	0	0	0	0	0	0	0	0	0	0	
	15	14	13	12	11	10	9	8	7	6	5	4	3	2	1	0	
	reserved															R1	R0
Type	RO	RO	RO	RO	RO	RO	RO	RO	RO	RO	RO	RO	RO	RO	R/W	R/W	
Reset	0	0	0	0	0	0	0	0	0	0	0	0	0	0	0	0	

Bit/Field	Name	Type	Reset	Description
31:2	reserved	RO	0	Software should not rely on the value of a reserved bit. To provide compatibility with future products, the value of a reserved bit should be preserved across a read-modify-write operation.
1	R1	R/W	0	QEI Module 1 Run Mode Clock Gating Control Value Description 1 Enable and provide a clock to QEI module 1 in Run mode. 0 QEI module 1 is disabled.
0	R0	R/W	0	QEI Module 0 Run Mode Clock Gating Control Value Description 1 Enable and provide a clock to QEI module 0 in Run mode. 0 QEI module 0 is disabled.

Register 62: EEPROM Run Mode Clock Gating Control (RCGCEEPROM), offset 0x658

The **RCGCEEPROM** register provides software the capability to enable and disable the EEPROM module in Run mode. When enabled, the module is provided a clock and accesses to module registers are allowed. When disabled, the clock is disabled to save power and accesses to module registers generate a bus fault.

EEPROM Run Mode Clock Gating Control (RCGCEEPROM)

Base 0x400F.E000
 Offset 0x658
 Type R/W, reset 0x0000.0000

	31	30	29	28	27	26	25	24	23	22	21	20	19	18	17	16
	reserved															
Type	RO	RO	RO	RO	RO	RO	RO	RO	RO	RO	RO	RO	RO	RO	RO	RO
Reset	0	0	0	0	0	0	0	0	0	0	0	0	0	0	0	0
	15	14	13	12	11	10	9	8	7	6	5	4	3	2	1	0
	reserved															RO
Type	RO	RO	RO	RO	RO	RO	RO	RO	RO	RO	RO	RO	RO	RO	RO	R/W
Reset	0	0	0	0	0	0	0	0	0	0	0	0	0	0	0	0

Bit/Field	Name	Type	Reset	Description
31:1	reserved	RO	0	Software should not rely on the value of a reserved bit. To provide compatibility with future products, the value of a reserved bit should be preserved across a read-modify-write operation.
0	R0	R/W	0	EEPROM Module Run Mode Clock Gating Control
				Value Description
			1	Enable and provide a clock to the EEPROM module in Run mode.
			0	EEPROM module is disabled.

Register 63: 32/64-Bit Wide General-Purpose Timer Run Mode Clock Gating Control (RCGCWTIMER), offset 0x65C

The **RCGCWTIMER** register provides software the capability to enable and disable 32/64-bit timer modules in Run mode. When enabled, a module is provided a clock and accesses to module registers are allowed. When disabled, the clock is disabled to save power and accesses to module registers generate a bus fault. This register provides the same capability as the legacy **Run Mode Clock Gating Control Register n RCGCn** registers specifically for the timer modules and has the same bit polarity as the corresponding **RCGCn** bits.

32/64-Bit Wide General-Purpose Timer Run Mode Clock Gating Control (RCGCWTIMER)

Base 0x400F.E000

Offset 0x65C

Type R/W, reset 0x0000.0000

	31	30	29	28	27	26	25	24	23	22	21	20	19	18	17	16	
	reserved																
Type	RO	RO	RO	RO	RO	RO	RO	RO	RO	RO	RO	RO	RO	RO	RO	RO	
Reset	0	0	0	0	0	0	0	0	0	0	0	0	0	0	0	0	
	15	14	13	12	11	10	9	8	7	6	5	4	3	2	1	0	
	reserved											R5	R4	R3	R2	R1	R0
Type	RO	RO	RO	RO	RO	RO	RO	RO	RO	RO	R/W	R/W	R/W	R/W	R/W	R/W	
Reset	0	0	0	0	0	0	0	0	0	0	0	0	0	0	0	0	

Bit/Field	Name	Type	Reset	Description
31:6	reserved	RO	0	Software should not rely on the value of a reserved bit. To provide compatibility with future products, the value of a reserved bit should be preserved across a read-modify-write operation.
5	R5	R/W	0	32/64-Bit Wide General-Purpose Timer 5 Run Mode Clock Gating Control Value Description 1 Enable and provide a clock to 32/64-bit wide general-purpose timer module 5 in Run mode. 0 32/64-bit wide general-purpose timer module 5 is disabled.
4	R4	R/W	0	32/64-Bit Wide General-Purpose Timer 4 Run Mode Clock Gating Control Value Description 1 Enable and provide a clock to 32/64-bit wide general-purpose timer module 4 in Run mode. 0 32/64-bit wide general-purpose timer module 4 is disabled.
3	R3	R/W	0	32/64-Bit Wide General-Purpose Timer 3 Run Mode Clock Gating Control Value Description 1 Enable and provide a clock to 32/64-bit wide general-purpose timer module 3 in Run mode. 0 32/64-bit wide general-purpose timer module 3 is disabled.

Bit/Field	Name	Type	Reset	Description
2	R2	R/W	0	32/64-Bit Wide General-Purpose Timer 2 Run Mode Clock Gating Control Value Description 1 Enable and provide a clock to 32/64-bit wide general-purpose timer module 2 in Run mode. 0 32/64-bit wide general-purpose timer module 2 is disabled.
1	R1	R/W	0	32/64-Bit Wide General-Purpose Timer 1 Run Mode Clock Gating Control Value Description 1 Enable and provide a clock to 32/64-bit wide general-purpose timer module 1 in Run mode. 0 32/64-bit wide general-purpose timer module 1 is disabled.
0	R0	R/W	0	32/64-Bit Wide General-Purpose Timer 0 Run Mode Clock Gating Control Value Description 1 Enable and provide a clock to 32/64-bit wide general-purpose timer module 0 in Run mode. 0 32/64-bit wide general-purpose timer module 0 is disabled.

Register 64: Watchdog Timer Sleep Mode Clock Gating Control (SCGCWD), offset 0x700

The **SCGCWD** register provides software the capability to enable and disable watchdog modules in sleep mode. When enabled, a module is provided a clock. When disabled, the clock is disabled to save power. This register provides the same capability as the legacy **Sleep Mode Clock Gating Control Register n SCGCn** registers specifically for the watchdog modules and has the same bit polarity as the corresponding **SCGCn** bits.

Important: This register should be used to control the clocking for the watchdog modules. To support legacy software, the **SCGC0** register is available. A write to the **SCGC0** register also writes the corresponding bit in this register. Any bits that are changed by writing to the **SCGC0** register can be read back correctly with a read of the **SCGC0** register. If software uses this register to write a legacy peripheral (such as Watchdog 0), the write causes proper operation, but the value of that bit is not reflected in the **SCGC0** register. If software uses both legacy and peripheral-specific register accesses, the peripheral-specific registers must be accessed by read-modify-write operations that affect only peripherals that are not present in the legacy registers. In this manner, both the peripheral-specific and legacy registers have coherent information.

Watchdog Timer Sleep Mode Clock Gating Control (SCGCWD)

Base 0x400F.E000
Offset 0x700
Type R/W, reset 0x0000.0000

	31	30	29	28	27	26	25	24	23	22	21	20	19	18	17	16	
	reserved																
Type	RO	RO	RO	RO	RO	RO	RO	RO	RO	RO	RO	RO	RO	RO	RO	RO	
Reset	0	0	0	0	0	0	0	0	0	0	0	0	0	0	0	0	
	15	14	13	12	11	10	9	8	7	6	5	4	3	2	1	0	
	reserved															S1	S0
Type	RO	RO	RO	RO	RO	RO	RO	RO	RO	RO	RO	RO	RO	RO	R/W	R/W	
Reset	0	0	0	0	0	0	0	0	0	0	0	0	0	0	0	0	

Bit/Field	Name	Type	Reset	Description
31:2	reserved	RO	0	Software should not rely on the value of a reserved bit. To provide compatibility with future products, the value of a reserved bit should be preserved across a read-modify-write operation.
1	S1	R/W	0	Watchdog Timer 1 Sleep Mode Clock Gating Control
				Value Description
				1 Enable and provide a clock to Watchdog module 1 in sleep mode.
				0 Watchdog module 1 is disabled.
0	S0	R/W	0	Watchdog Timer 0 Sleep Mode Clock Gating Control
				Value Description
				1 Enable and provide a clock to Watchdog module 0 in sleep mode.
				0 Watchdog module 0 is disabled.

Register 65: 16/32-Bit General-Purpose Timer Sleep Mode Clock Gating Control (SCGCTIMER), offset 0x704

The **SCGCTIMER** register provides software the capability to enable and disable 16/32-bit timer modules in sleep mode. When enabled, a module is provided a clock. When disabled, the clock is disabled to save power. This register provides the same capability as the legacy **Sleep Mode Clock Gating Control Register n SCGCn** registers specifically for the timer modules and has the same bit polarity as the corresponding **SCGCn** bits.

Important: This register should be used to control the clocking for the timer modules. To support legacy software, the **SCGC1** register is available. A write to the **SCGC1** register also writes the corresponding bit in this register. Any bits that are changed by writing to the **SCGC1** register can be read back correctly with a read of the **SCGC1** register. Software must use this register to support modules that are not present in the legacy registers. If software uses this register to write a legacy peripheral (such as Timer 0), the write causes proper operation, but the value of that bit is not reflected in the **SCGC1** register. If software uses both legacy and peripheral-specific register accesses, the peripheral-specific registers must be accessed by read-modify-write operations that affect only peripherals that are not present in the legacy registers. In this manner, both the peripheral-specific and legacy registers have coherent information.

16/32-Bit General-Purpose Timer Sleep Mode Clock Gating Control (SCGCTIMER)

Base 0x400F.E000
 Offset 0x704
 Type R/W, reset 0x0000.0000

	31	30	29	28	27	26	25	24	23	22	21	20	19	18	17	16	
	reserved																
Type	RO	RO	RO	RO	RO	RO	RO	RO	RO	RO	RO	RO	RO	RO	RO	RO	
Reset	0	0	0	0	0	0	0	0	0	0	0	0	0	0	0	0	
	15	14	13	12	11	10	9	8	7	6	5	4	3	2	1	0	
	reserved											S5	S4	S3	S2	S1	S0
Type	RO	RO	RO	RO	RO	RO	RO	RO	RO	RO	R/W	R/W	R/W	R/W	R/W	R/W	
Reset	0	0	0	0	0	0	0	0	0	0	0	0	0	0	0	0	

Bit/Field	Name	Type	Reset	Description
31:6	reserved	RO	0	Software should not rely on the value of a reserved bit. To provide compatibility with future products, the value of a reserved bit should be preserved across a read-modify-write operation.
5	S5	R/W	0	16/32-Bit General-Purpose Timer 5 Sleep Mode Clock Gating Control Value Description 1 Enable and provide a clock to 16/32-bit general-purpose timer module 5 in sleep mode. 0 16/32-bit general-purpose timer module 5 is disabled.
4	S4	R/W	0	16/32-Bit General-Purpose Timer 4 Sleep Mode Clock Gating Control Value Description 1 Enable and provide a clock to 16/32-bit general-purpose timer module 4 in sleep mode. 0 16/32-bit general-purpose timer module 4 is disabled.

Bit/Field	Name	Type	Reset	Description
3	S3	R/W	0	16/32-Bit General-Purpose Timer 3 Sleep Mode Clock Gating Control Value Description 1 Enable and provide a clock to 16/32-bit general-purpose timer module 3 in sleep mode. 0 16/32-bit general-purpose timer module 3 is disabled.
2	S2	R/W	0	16/32-Bit General-Purpose Timer 2 Sleep Mode Clock Gating Control Value Description 1 Enable and provide a clock to 16/32-bit general-purpose timer module 2 in sleep mode. 0 16/32-bit general-purpose timer module 2 is disabled.
1	S1	R/W	0	16/32-Bit General-Purpose Timer 1 Sleep Mode Clock Gating Control Value Description 1 Enable and provide a clock to 16/32-bit general-purpose timer module 1 in sleep mode. 0 16/32-bit general-purpose timer module 1 is disabled.
0	S0	R/W	0	16/32-Bit General-Purpose Timer 0 Sleep Mode Clock Gating Control Value Description 1 Enable and provide a clock to 16/32-bit general-purpose timer module 0 in sleep mode. 0 16/32-bit general-purpose timer module 0 is disabled.

Register 66: General-Purpose Input/Output Sleep Mode Clock Gating Control (SCGCGPIO), offset 0x708

The **SCGCGPIO** register provides software the capability to enable and disable GPIO modules in sleep mode. When enabled, a module is provided a clock. When disabled, the clock is disabled to save power. This register provides the same capability as the legacy **Sleep Mode Clock Gating Control Register n SCGCn** registers specifically for the watchdog modules and has the same bit polarity as the corresponding **SCGCn** bits.

Important: This register should be used to control the clocking for the GPIO modules. To support legacy software, the **SCGC2** register is available. A write to the **SCGC2** register also writes the corresponding bit in this register. Any bits that are changed by writing to the **SCGC2** register can be read back correctly with a read of the **SCGC2** register. Software must use this register to support modules that are not present in the legacy registers. If software uses this register to write a legacy peripheral (such as GPIO A), the write causes proper operation, but the value of that bit is not reflected in the **SCGC2** register. If software uses both legacy and peripheral-specific register accesses, the peripheral-specific registers must be accessed by read-modify-write operations that affect only peripherals that are not present in the legacy registers. In this manner, both the peripheral-specific and legacy registers have coherent information.

General-Purpose Input/Output Sleep Mode Clock Gating Control (SCGCGPIO)

Base 0x400F.E000
 Offset 0x708
 Type R/W, reset 0x0000.0000

	31	30	29	28	27	26	25	24	23	22	21	20	19	18	17	16	
	reserved																
Type	RO	RO	RO	RO	RO	RO	RO	RO	RO	RO	RO	RO	RO	RO	RO	RO	
Reset	0	0	0	0	0	0	0	0	0	0	0	0	0	0	0	0	
	15	14	13	12	11	10	9	8	7	6	5	4	3	2	1	0	
	reserved										S6	S5	S4	S3	S2	S1	S0
Type	RO	RO	RO	RO	RO	RO	RO	RO	RO	R/W	R/W	R/W	R/W	R/W	R/W	R/W	
Reset	0	0	0	0	0	0	0	0	0	0	0	0	0	0	0	0	

Bit/Field	Name	Type	Reset	Description
31:7	reserved	RO	0	Software should not rely on the value of a reserved bit. To provide compatibility with future products, the value of a reserved bit should be preserved across a read-modify-write operation.
6	S6	R/W	0	GPIO Port G Sleep Mode Clock Gating Control Value Description 1 Enable and provide a clock to GPIO Port G in sleep mode. 0 GPIO Port G is disabled.
5	S5	R/W	0	GPIO Port F Sleep Mode Clock Gating Control Value Description 1 Enable and provide a clock to GPIO Port F in sleep mode. 0 GPIO Port F is disabled.

Bit/Field	Name	Type	Reset	Description
4	S4	R/W	0	GPIO Port E Sleep Mode Clock Gating Control Value Description 1 Enable and provide a clock to GPIO Port E in sleep mode. 0 GPIO Port E is disabled.
3	S3	R/W	0	GPIO Port D Sleep Mode Clock Gating Control Value Description 1 Enable and provide a clock to GPIO Port D in sleep mode. 0 GPIO Port D is disabled.
2	S2	R/W	0	GPIO Port C Sleep Mode Clock Gating Control Value Description 1 Enable and provide a clock to GPIO Port C in sleep mode. 0 GPIO Port C is disabled.
1	S1	R/W	0	GPIO Port B Sleep Mode Clock Gating Control Value Description 1 Enable and provide a clock to GPIO Port B in sleep mode. 0 GPIO Port B is disabled.
0	S0	R/W	0	GPIO Port A Sleep Mode Clock Gating Control Value Description 1 Enable and provide a clock to GPIO Port A in sleep mode. 0 GPIO Port A is disabled.

Register 67: Micro Direct Memory Access Sleep Mode Clock Gating Control (SCGCDMA), offset 0x70C

The **SCGCDMA** register provides software the capability to enable and disable the μ DMA module in sleep mode. When enabled, a module is provided a clock. When disabled, the clock is disabled to save power. This register provides the same capability as the legacy **Sleep Mode Clock Gating Control Register n SCGCn** registers specifically for the watchdog modules and has the same bit polarity as the corresponding **SCGCn** bits.

Important: This register should be used to control the clocking for the μ DMA module. To support legacy software, the **SCGC2** register is available. A write to the **UDMA** bit in the **SCGC2** register also writes the **S0** bit in this register. If the **UDMA** bit is changed by writing to the **SCGC2** register, it can be read back correctly with a read of the **SCGC2** register. If software uses this register to control the clock for the μ DMA module, the write causes proper operation, but the **UDMA** bit in the **SCGC2** register does not reflect the value of the **S0** bit. If software uses both legacy and peripheral-specific register accesses, the peripheral-specific registers must be accessed by read-modify-write operations that affect only peripherals that are not present in the legacy registers. In this manner, both the peripheral-specific and legacy registers have coherent information.

Micro Direct Memory Access Sleep Mode Clock Gating Control (SCGCDMA)

Base 0x400F.E000
 Offset 0x70C
 Type R/W, reset 0x0000.0000

	31	30	29	28	27	26	25	24	23	22	21	20	19	18	17	16
	reserved															
Type	RO	RO	RO	RO	RO	RO	RO	RO	RO	RO	RO	RO	RO	RO	RO	RO
Reset	0	0	0	0	0	0	0	0	0	0	0	0	0	0	0	0
	15	14	13	12	11	10	9	8	7	6	5	4	3	2	1	0
	reserved															S0
Type	RO	RO	RO	RO	RO	RO	RO	RO	RO	RO	RO	RO	RO	RO	RO	R/W
Reset	0	0	0	0	0	0	0	0	0	0	0	0	0	0	0	0

Bit/Field	Name	Type	Reset	Description
31:1	reserved	RO	0	Software should not rely on the value of a reserved bit. To provide compatibility with future products, the value of a reserved bit should be preserved across a read-modify-write operation.
0	S0	R/W	0	μ DMA Module Sleep Mode Clock Gating Control
				Value Description
				1 Enable and provide a clock to the μ DMA module in sleep mode.
				0 μ DMA module is disabled.

Register 68: Universal Asynchronous Receiver/Transmitter Sleep Mode Clock Gating Control (SCGCUART), offset 0x718

The **SCGCUART** register provides software the capability to enable and disable the UART modules in sleep mode. When enabled, a module is provided a clock. When disabled, the clock is disabled to save power. This register provides the same capability as the legacy **Sleep Mode Clock Gating Control Register n SCGCn** registers specifically for the watchdog modules and has the same bit polarity as the corresponding **SCGCn** bits.

Important: This register should be used to control the clocking for the UART modules. To support legacy software, the **SCGC1** register is available. A write to the **SCGC1** register also writes the corresponding bit in this register. Any bits that are changed by writing to the **SCGC1** register can be read back correctly with a read of the **SCGC1** register. Software must use this register to support modules that are not present in the legacy registers. If software uses this register to write a legacy peripheral (such as UART0), the write causes proper operation, but the value of that bit is not reflected in the **SCGC1** register. If software uses both legacy and peripheral-specific register accesses, the peripheral-specific registers must be accessed by read-modify-write operations that affect only peripherals that are not present in the legacy registers. In this manner, both the peripheral-specific and legacy registers have coherent information.

Universal Asynchronous Receiver/Transmitter Sleep Mode Clock Gating Control (SCGCUART)

Base 0x400F.E000
Offset 0x718
Type R/W, reset 0x0000.0000

	31	30	29	28	27	26	25	24	23	22	21	20	19	18	17	16
	reserved															
Type	RO	RO	RO	RO	RO	RO	RO	RO	RO	RO	RO	RO	RO	RO	RO	RO
Reset	0	0	0	0	0	0	0	0	0	0	0	0	0	0	0	0
	15	14	13	12	11	10	9	8	7	6	5	4	3	2	1	0
	reserved								S7	S6	S5	S4	S3	S2	S1	S0
Type	RO	RO	RO	RO	RO	RO	RO	RO	R/W	R/W	R/W	R/W	R/W	R/W	R/W	R/W
Reset	0	0	0	0	0	0	0	0	0	0	0	0	0	0	0	0

Bit/Field	Name	Type	Reset	Description
31:8	reserved	RO	0	Software should not rely on the value of a reserved bit. To provide compatibility with future products, the value of a reserved bit should be preserved across a read-modify-write operation.
7	S7	R/W	0	UART Module 7 Sleep Mode Clock Gating Control Value Description 1 Enable and provide a clock to UART module 7 in sleep mode. 0 UART module 7 is disabled.
6	S6	R/W	0	UART Module 6 Sleep Mode Clock Gating Control Value Description 1 Enable and provide a clock to UART module 6 in sleep mode. 0 UART module 6 is disabled.

Bit/Field	Name	Type	Reset	Description
5	S5	R/W	0	UART Module 5 Sleep Mode Clock Gating Control Value Description 1 Enable and provide a clock to UART module 5 in sleep mode. 0 UART module 5 is disabled.
4	S4	R/W	0	UART Module 4 Sleep Mode Clock Gating Control Value Description 1 Enable and provide a clock to UART module 4 in sleep mode. 0 UART module 4 is disabled.
3	S3	R/W	0	UART Module 3 Sleep Mode Clock Gating Control Value Description 1 Enable and provide a clock to UART module 3 in sleep mode. 0 UART module 3 is disabled.
2	S2	R/W	0	UART Module 2 Sleep Mode Clock Gating Control Value Description 1 Enable and provide a clock to UART module 2 in sleep mode. 0 UART module 2 is disabled.
1	S1	R/W	0	UART Module 1 Sleep Mode Clock Gating Control Value Description 1 Enable and provide a clock to UART module 1 in sleep mode. 0 UART module 1 is disabled.
0	S0	R/W	0	UART Module 0 Sleep Mode Clock Gating Control Value Description 1 Enable and provide a clock to UART module 0 in sleep mode. 0 UART module 0 is disabled.

Register 69: Synchronous Serial Interface Sleep Mode Clock Gating Control (SCGCSSI), offset 0x71C

The **SCGCSSI** register provides software the capability to enable and disable the SSI modules in sleep mode. When enabled, a module is provided a clock. When disabled, the clock is disabled to save power. This register provides the same capability as the legacy **Sleep Mode Clock Gating Control Register n SCGCn** registers specifically for the watchdog modules and has the same bit polarity as the corresponding **SCGCn** bits.

Important: This register should be used to control the clocking for the SSI modules. To support legacy software, the **SCGC1** register is available. A write to the **SCGC1** register also writes the corresponding bit in this register. Any bits that are changed by writing to the **SCGC1** register can be read back correctly with a read of the **SCGC1** register. Software must use this register to support modules that are not present in the legacy registers. If software uses this register to write a legacy peripheral (such as SSI0), the write causes proper operation, but the value of that bit is not reflected in the **SCGC1** register. If software uses both legacy and peripheral-specific register accesses, the peripheral-specific registers must be accessed by read-modify-write operations that affect only peripherals that are not present in the legacy registers. In this manner, both the peripheral-specific and legacy registers have coherent information.

Synchronous Serial Interface Sleep Mode Clock Gating Control (SCGCSSI)

Base 0x400F.E000
Offset 0x71C
Type R/W, reset 0x0000.0000

	31	30	29	28	27	26	25	24	23	22	21	20	19	18	17	16
	reserved															
Type	RO	RO	RO	RO	RO	RO	RO	RO	RO	RO	RO	RO	RO	RO	RO	RO
Reset	0	0	0	0	0	0	0	0	0	0	0	0	0	0	0	0
	15	14	13	12	11	10	9	8	7	6	5	4	3	2	1	0
	reserved												S3	S2	S1	S0
Type	RO	RO	RO	RO	RO	RO	RO	RO	RO	RO	RO	RO	R/W	R/W	R/W	R/W
Reset	0	0	0	0	0	0	0	0	0	0	0	0	0	0	0	0

Bit/Field	Name	Type	Reset	Description
31:4	reserved	RO	0	Software should not rely on the value of a reserved bit. To provide compatibility with future products, the value of a reserved bit should be preserved across a read-modify-write operation.
3	S3	R/W	0	SSI Module 3 Sleep Mode Clock Gating Control Value Description 1 Enable and provide a clock to SSI module 3 in sleep mode. 0 SSI module 3 is disabled.
2	S2	R/W	0	SSI Module 2 Sleep Mode Clock Gating Control Value Description 1 Enable and provide a clock to SSI module 2 in sleep mode. 0 SSI module 2 is disabled.

Bit/Field	Name	Type	Reset	Description
1	S1	R/W	0	SSI Module 1 Sleep Mode Clock Gating Control Value Description 1 Enable and provide a clock to SSI module 1 in sleep mode. 0 SSI module 1 is disabled.
0	S0	R/W	0	SSI Module 0 Sleep Mode Clock Gating Control Value Description 1 Enable and provide a clock to SSI module 0 in sleep mode. 0 SSI module 0 is disabled.

Register 70: Inter-Integrated Circuit Sleep Mode Clock Gating Control (SCGCI2C), offset 0x720

The **SCGCI2C** register provides software the capability to enable and disable the I²C modules in sleep mode. When enabled, a module is provided a clock. When disabled, the clock is disabled to save power. This register provides the same capability as the legacy **Sleep Mode Clock Gating Control Register n SCGCn** registers specifically for the watchdog modules and has the same bit polarity as the corresponding **SCGCn** bits.

Important: This register should be used to control the clocking for the I²C modules. To support legacy software, the **SCGC1** register is available. A write to the **SCGC1** register also writes the corresponding bit in this register. Any bits that are changed by writing to the **SCGC1** register can be read back correctly with a read of the **SCGC1** register. Software must use this register to support modules that are not present in the legacy registers. If software uses this register to write a legacy peripheral (such as I²C0), the write causes proper operation, but the value of that bit is not reflected in the **SCGC1** register. If software uses both legacy and peripheral-specific register accesses, the peripheral-specific registers must be accessed by read-modify-write operations that affect only peripherals that are not present in the legacy registers. In this manner, both the peripheral-specific and legacy registers have coherent information.

Inter-Integrated Circuit Sleep Mode Clock Gating Control (SCGCI2C)

Base 0x400F.E000
Offset 0x720
Type R/W, reset 0x0000.0000

	31	30	29	28	27	26	25	24	23	22	21	20	19	18	17	16	
	reserved																
Type	RO	RO	RO	RO	RO	RO	RO	RO	RO	RO	RO	RO	RO	RO	RO	RO	
Reset	0	0	0	0	0	0	0	0	0	0	0	0	0	0	0	0	
	15	14	13	12	11	10	9	8	7	6	5	4	3	2	1	0	
	reserved											S5	S4	S3	S2	S1	S0
Type	RO	RO	RO	RO	RO	RO	RO	RO	RO	RO	R/W	R/W	R/W	R/W	R/W	R/W	
Reset	0	0	0	0	0	0	0	0	0	0	0	0	0	0	0	0	

Bit/Field	Name	Type	Reset	Description
31:6	reserved	RO	0	Software should not rely on the value of a reserved bit. To provide compatibility with future products, the value of a reserved bit should be preserved across a read-modify-write operation.
5	S5	R/W	0	I ² C Module 5 Sleep Mode Clock Gating Control Value Description 1 Enable and provide a clock to I ² C module 5 in sleep mode. 0 I ² C module 5 is disabled.
4	S4	R/W	0	I ² C Module 4 Sleep Mode Clock Gating Control Value Description 1 Enable and provide a clock to I ² C module 4 in sleep mode. 0 I ² C module 4 is disabled.

Bit/Field	Name	Type	Reset	Description
3	S3	R/W	0	I ² C Module 3 Sleep Mode Clock Gating Control Value Description 1 Enable and provide a clock to I ² C module 3 in sleep mode. 0 I ² C module 3 is disabled.
2	S2	R/W	0	I ² C Module 2 Sleep Mode Clock Gating Control Value Description 1 Enable and provide a clock to I ² C module 2 in sleep mode. 0 I ² C module 2 is disabled.
1	S1	R/W	0	I ² C Module 1 Sleep Mode Clock Gating Control Value Description 1 Enable and provide a clock to I ² C module 1 in sleep mode. 0 I ² C module 1 is disabled.
0	S0	R/W	0	I ² C Module 0 Sleep Mode Clock Gating Control Value Description 1 Enable and provide a clock to I ² C module 0 in sleep mode. 0 I ² C module 0 is disabled.

Register 71: Universal Serial Bus Sleep Mode Clock Gating Control (SCGCUSB), offset 0x728

The **SCGCUSB** register provides software the capability to enable and disable the USB module in sleep mode. When enabled, a module is provided a clock. When disabled, the clock is disabled to save power. This register provides the same capability as the legacy **Sleep Mode Clock Gating Control Register n SCGCn** registers specifically for the watchdog modules and has the same bit polarity as the corresponding **SCGCn** bits.

Important: This register should be used to control the clocking for the USB module. To support legacy software, the **SCGC2** register is available. A write to the **USB0** bit in the **SCGC2** register also writes the **S0** bit in this register. If the **USB0** bit is changed by writing to the **SCGC2** register, it can be read back correctly with a read of the **SCGC2** register. If software uses this register to control the clock for the USB module, the write causes proper operation, but the **USB0** bit in the **SCGC2** register does not reflect the value of the **S0** bit. If software uses both legacy and peripheral-specific register accesses, the peripheral-specific registers must be accessed by read-modify-write operations that affect only peripherals that are not present in the legacy registers. In this manner, both the peripheral-specific and legacy registers have coherent information.

Universal Serial Bus Sleep Mode Clock Gating Control (SCGCUSB)

Base 0x400F.E000
Offset 0x728
Type R/W, reset 0x0000.0000

	31	30	29	28	27	26	25	24	23	22	21	20	19	18	17	16
	reserved															
Type	RO	RO	RO	RO	RO	RO	RO	RO	RO	RO	RO	RO	RO	RO	RO	RO
Reset	0	0	0	0	0	0	0	0	0	0	0	0	0	0	0	0
	15	14	13	12	11	10	9	8	7	6	5	4	3	2	1	0
	reserved															S0
Type	RO	RO	RO	RO	RO	RO	RO	RO	RO	RO	RO	RO	RO	RO	RO	R/W
Reset	0	0	0	0	0	0	0	0	0	0	0	0	0	0	0	0

Bit/Field	Name	Type	Reset	Description
31:1	reserved	RO	0	Software should not rely on the value of a reserved bit. To provide compatibility with future products, the value of a reserved bit should be preserved across a read-modify-write operation.
0	S0	R/W	0	USB Module Sleep Mode Clock Gating Control
				Value Description
				1 Enable and provide a clock to the USB module in sleep mode.
				0 USB module is disabled.

Register 72: Controller Area Network Sleep Mode Clock Gating Control (SCGCCAN), offset 0x734

The **SCGCCAN** register provides software the capability to enable and disable the CAN modules in sleep mode. When enabled, a module is provided a clock. When disabled, the clock is disabled to save power. This register provides the same capability as the legacy **Sleep Mode Clock Gating Control Register n SCGCn** registers specifically for the watchdog modules and has the same bit polarity as the corresponding **SCGCn** bits.

Important: This register should be used to control the clocking for the CAN modules. To support legacy software, the **SCGC0** register is available. A write to the **SCGC0** register also writes the corresponding bit in this register. Any bits that are changed by writing to the **SCGC0** register can be read back correctly with a read of the **SCGC0** register. If software uses this register to write a legacy peripheral (such as CAN0), the write causes proper operation, but the value of that bit is not reflected in the **SCGC0** register. If software uses both legacy and peripheral-specific register accesses, the peripheral-specific registers must be accessed by read-modify-write operations that affect only peripherals that are not present in the legacy registers. In this manner, both the peripheral-specific and legacy registers have coherent information.

Controller Area Network Sleep Mode Clock Gating Control (SCGCCAN)

Base 0x400F.E000
 Offset 0x734
 Type R/W, reset 0x0000.0000

	31	30	29	28	27	26	25	24	23	22	21	20	19	18	17	16	
	reserved																
Type	RO	RO	RO	RO	RO	RO	RO	RO	RO	RO	RO	RO	RO	RO	RO	RO	
Reset	0	0	0	0	0	0	0	0	0	0	0	0	0	0	0	0	
	15	14	13	12	11	10	9	8	7	6	5	4	3	2	1	0	
	reserved															S1	S0
Type	RO	RO	RO	RO	RO	RO	RO	RO	RO	RO	RO	RO	RO	RO	R/W	R/W	
Reset	0	0	0	0	0	0	0	0	0	0	0	0	0	0	0	0	

Bit/Field	Name	Type	Reset	Description
31:2	reserved	RO	0	Software should not rely on the value of a reserved bit. To provide compatibility with future products, the value of a reserved bit should be preserved across a read-modify-write operation.
1	S1	R/W	0	CAN Module 1 Sleep Mode Clock Gating Control Value Description 1 Enable and provide a clock to CAN module 1 in sleep mode. 0 CAN module 1 is disabled.
0	S0	R/W	0	CAN Module 0 Sleep Mode Clock Gating Control Value Description 1 Enable and provide a clock to CAN module 0 in sleep mode. 0 CAN module 0 is disabled.

Register 73: Analog-to-Digital Converter Sleep Mode Clock Gating Control (SCGCADC), offset 0x738

The **SCGCADC** register provides software the capability to enable and disable the ADC modules in sleep mode. When enabled, a module is provided a clock. When disabled, the clock is disabled to save power. This register provides the same capability as the legacy **Sleep Mode Clock Gating Control Register n SCGCn** registers specifically for the watchdog modules and has the same bit polarity as the corresponding **SCGCn** bits.

Important: This register should be used to control the clocking for the ADC modules. To support legacy software, the **SCGC0** register is available. A write to the **SCGC0** register also writes the corresponding bit in this register. Any bits that are changed by writing to the **SCGC0** register can be read back correctly with a read of the **SCGC0** register. If software uses this register to write a legacy peripheral (such as ADC0), the write causes proper operation, but the value of that bit is not reflected in the **SCGC0** register. If software uses both legacy and peripheral-specific register accesses, the peripheral-specific registers must be accessed by read-modify-write operations that affect only peripherals that are not present in the legacy registers. In this manner, both the peripheral-specific and legacy registers have coherent information.

Analog-to-Digital Converter Sleep Mode Clock Gating Control (SCGCADC)

Base 0x400F.E000
Offset 0x738
Type R/W, reset 0x0000.0000

	31	30	29	28	27	26	25	24	23	22	21	20	19	18	17	16	
	reserved																
Type	RO	RO	RO	RO	RO	RO	RO	RO	RO	RO	RO	RO	RO	RO	RO	RO	
Reset	0	0	0	0	0	0	0	0	0	0	0	0	0	0	0	0	
	15	14	13	12	11	10	9	8	7	6	5	4	3	2	1	0	
	reserved															S1	S0
Type	RO	RO	RO	RO	RO	RO	RO	RO	RO	RO	RO	RO	RO	RO	R/W	R/W	
Reset	0	0	0	0	0	0	0	0	0	0	0	0	0	0	0	0	

Bit/Field	Name	Type	Reset	Description
31:2	reserved	RO	0	Software should not rely on the value of a reserved bit. To provide compatibility with future products, the value of a reserved bit should be preserved across a read-modify-write operation.
1	S1	R/W	0	ADC Module 1 Sleep Mode Clock Gating Control Value Description 1 Enable and provide a clock to ADC module 1 in sleep mode. 0 ADC module 1 is disabled.
0	S0	R/W	0	ADC Module 0 Sleep Mode Clock Gating Control Value Description 1 Enable and provide a clock to ADC module 0 in sleep mode. 0 ADC module 0 is disabled.

Register 74: Analog Comparator Sleep Mode Clock Gating Control (SCGCACMP), offset 0x73C

The **SCGCACMP** register provides software the capability to enable and disable the analog comparator module in sleep mode. When enabled, a module is provided a clock. When disabled, the clock is disabled to save power. This register provides the same capability as the legacy **Sleep Mode Clock Gating Control Register n SCGCn** registers specifically for the watchdog modules and has the same bit polarity as the corresponding **SCGCn** bits.

Important: This register should be used to control the clocking for the analog comparator module. To support legacy software, the **SCGC1** register is available. Setting any of the **COMPn** bits in the **SCGC1** register also sets the **S0** bit in this register. If any of the **COMPn** bits are set by writing to the **SCGC1** register, it can be read back correctly when reading the **SCGC1** register. If software uses this register to change the clocking for the analog comparator module, the write causes proper operation, but the value **S0** is not reflected by the **COMPn** bits in the **SCGC1** register. If software uses both legacy and peripheral-specific register accesses, the peripheral-specific registers must be accessed by read-modify-write operations that affect only peripherals that are not present in the legacy registers. In this manner, both the peripheral-specific and legacy registers have coherent information.

Analog Comparator Sleep Mode Clock Gating Control (SCGCACMP)

Base 0x400F.E000
 Offset 0x73C
 Type R/W, reset 0x0000.0000

	31	30	29	28	27	26	25	24	23	22	21	20	19	18	17	16
	reserved															
Type	RO	RO	RO	RO	RO	RO	RO	RO	RO	RO	RO	RO	RO	RO	RO	RO
Reset	0	0	0	0	0	0	0	0	0	0	0	0	0	0	0	0
	15	14	13	12	11	10	9	8	7	6	5	4	3	2	1	0
	reserved															S0
Type	RO	RO	RO	RO	RO	RO	RO	RO	RO	RO	RO	RO	RO	RO	RO	R/W
Reset	0	0	0	0	0	0	0	0	0	0	0	0	0	0	0	0

Bit/Field	Name	Type	Reset	Description
31:1	reserved	RO	0	Software should not rely on the value of a reserved bit. To provide compatibility with future products, the value of a reserved bit should be preserved across a read-modify-write operation.
0	S0	R/W	0	Analog Comparator Module 0 Sleep Mode Clock Gating Control
				Value Description
				1 Enable and provide a clock to the analog comparator module in sleep mode.
				0 Analog comparator module is disabled.

Register 75: Pulse Width Modulator Sleep Mode Clock Gating Control (SCGCPWM), offset 0x740

The **SCGCPWM** register provides software the capability to enable and disable the PWM modules in sleep mode. When enabled, a module is provided a clock. When disabled, the clock is disabled to save power. This register provides the same capability as the legacy **Sleep Mode Clock Gating Control Register n SCGCn** registers specifically for the watchdog modules and has the same bit polarity as the corresponding **SCGCn** bits.

Important: This register should be used to control the clocking for the PWM modules. To support legacy software, the **SCGC0** register is available. A write to the **PWM** bit in the **SCGC0** register also writes the **S0** bit in this register. If the **PWM** bit is changed by writing to the **SCGC0** register, it can be read back correctly with a read of the **SCGC0** register. Software must use this register to support modules that are not present in the legacy registers. If software uses this register to write to **S0**, the write causes proper operation, but the value of that bit is not reflected in the **PWM** bit in the **SCGC0** register. If software uses both legacy and peripheral-specific register accesses, the peripheral-specific registers must be accessed by read-modify-write operations that affect only peripherals that are not present in the legacy registers. In this manner, both the peripheral-specific and legacy registers have coherent information.

Pulse Width Modulator Sleep Mode Clock Gating Control (SCGCPWM)

Base 0x400F.E000
Offset 0x740
Type R/W, reset 0x0000.0000

	31	30	29	28	27	26	25	24	23	22	21	20	19	18	17	16	
	reserved																
Type	RO	RO	RO	RO	RO	RO	RO	RO	RO	RO	RO	RO	RO	RO	RO	RO	
Reset	0	0	0	0	0	0	0	0	0	0	0	0	0	0	0	0	
	15	14	13	12	11	10	9	8	7	6	5	4	3	2	1	0	
	reserved															S1	S0
Type	RO	RO	RO	RO	RO	RO	RO	RO	RO	RO	RO	RO	RO	RO	R/W	R/W	
Reset	0	0	0	0	0	0	0	0	0	0	0	0	0	0	0	0	

Bit/Field	Name	Type	Reset	Description
31:2	reserved	RO	0	Software should not rely on the value of a reserved bit. To provide compatibility with future products, the value of a reserved bit should be preserved across a read-modify-write operation.
1	S1	R/W	0	PWM Module 1 Sleep Mode Clock Gating Control Value Description 1 Enable and provide a clock to PWM module 1 in sleep mode. 0 PWM module 1 is disabled.
0	S0	R/W	0	PWM Module 0 Sleep Mode Clock Gating Control Value Description 1 Enable and provide a clock to PWM module 0 in sleep mode. 0 PWM module 0 is disabled.

Register 76: Quadrature Encoder Interface Sleep Mode Clock Gating Control (SCGCQEI), offset 0x744

The **SCGCQEI** register provides software the capability to enable and disable the QEI modules in sleep mode. When enabled, a module is provided a clock. When disabled, the clock is disabled to save power. This register provides the same capability as the legacy **Sleep Mode Clock Gating Control Register n SCGCn** registers specifically for the watchdog modules and has the same bit polarity as the corresponding **SCGCn** bits.

Important: This register should be used to control the clocking for the QEI modules. To support legacy software, the **SCGC1** register is available. A write to the **SCGC1** register also writes the corresponding bit in this register. Any bits that are changed by writing to the **SCGC1** register can be read back correctly with a read of the **SCGC1** register. If software uses this register to write a legacy peripheral (such as QEI0), the write causes proper operation, but the value of that bit is not reflected in the **SCGC1** register. If software uses both legacy and peripheral-specific register accesses, the peripheral-specific registers must be accessed by read-modify-write operations that affect only peripherals that are not present in the legacy registers. In this manner, both the peripheral-specific and legacy registers have coherent information.

Quadrature Encoder Interface Sleep Mode Clock Gating Control (SCGCQEI)

Base 0x400F.E000
 Offset 0x744
 Type R/W, reset 0x0000.0000

	31	30	29	28	27	26	25	24	23	22	21	20	19	18	17	16	
	reserved																
Type	RO	RO	RO	RO	RO	RO	RO	RO	RO	RO	RO	RO	RO	RO	RO	RO	
Reset	0	0	0	0	0	0	0	0	0	0	0	0	0	0	0	0	
	15	14	13	12	11	10	9	8	7	6	5	4	3	2	1	0	
	reserved															S1	S0
Type	RO	RO	RO	RO	RO	RO	RO	RO	RO	RO	RO	RO	RO	RO	R/W	R/W	
Reset	0	0	0	0	0	0	0	0	0	0	0	0	0	0	0	0	

Bit/Field	Name	Type	Reset	Description
31:2	reserved	RO	0	Software should not rely on the value of a reserved bit. To provide compatibility with future products, the value of a reserved bit should be preserved across a read-modify-write operation.
1	S1	R/W	0	QEI Module 1 Sleep Mode Clock Gating Control Value Description 1 Enable and provide a clock to QEI module 1 in sleep mode. 0 QEI module 1 is disabled.
0	S0	R/W	0	QEI Module 0 Sleep Mode Clock Gating Control Value Description 1 Enable and provide a clock to QEI module 0 in sleep mode. 0 QEI module 0 is disabled.

Register 77: EEPROM Sleep Mode Clock Gating Control (SCGCEEPROM), offset 0x758

The **SCGCEEPROM** register provides software the capability to enable and disable the EEPROM module in sleep mode. When enabled, a module is provided a clock. When disabled, the clock is disabled to save power.

EEPROM Sleep Mode Clock Gating Control (SCGCEEPROM)

Base 0x400F.E000

Offset 0x758

Type R/W, reset 0x0000.0000

	31	30	29	28	27	26	25	24	23	22	21	20	19	18	17	16
	reserved															
Type	RO	RO	RO	RO	RO	RO	RO	RO	RO	RO	RO	RO	RO	RO	RO	RO
Reset	0	0	0	0	0	0	0	0	0	0	0	0	0	0	0	0
	15	14	13	12	11	10	9	8	7	6	5	4	3	2	1	0
	reserved															S0
Type	RO	RO	RO	RO	RO	RO	RO	RO	RO	RO	RO	RO	RO	RO	RO	R/W
Reset	0	0	0	0	0	0	0	0	0	0	0	0	0	0	0	0

Bit/Field	Name	Type	Reset	Description
31:1	reserved	RO	0	Software should not rely on the value of a reserved bit. To provide compatibility with future products, the value of a reserved bit should be preserved across a read-modify-write operation.
0	S0	R/W	0	EEPROM Module Sleep Mode Clock Gating Control
Value Description				
	1			Enable and provide a clock to the EEPROM module in sleep mode.
	0			EEPROM module is disabled.

Register 78: 32/64-Bit Wide General-Purpose Timer Sleep Mode Clock Gating Control (SCGCWTIMER), offset 0x75C

The **SCGCWTIMER** register provides software the capability to enable and disable 32/64-bit timer modules in sleep mode. When enabled, a module is provided a clock. When disabled, the clock is disabled to save power. This register provides the same capability as the legacy **Sleep Mode Clock Gating Control Register n SCGCn** registers specifically for the timer modules and has the same bit polarity as the corresponding **SCGCn** bits.

32/64-Bit Wide General-Purpose Timer Sleep Mode Clock Gating Control (SCGCWTIMER)

Base 0x400F.E000
 Offset 0x75C
 Type R/W, reset 0x0000.0000

	31	30	29	28	27	26	25	24	23	22	21	20	19	18	17	16	
	reserved																
Type	RO	RO	RO	RO	RO	RO	RO	RO	RO	RO	RO	RO	RO	RO	RO	RO	
Reset	0	0	0	0	0	0	0	0	0	0	0	0	0	0	0	0	
	15	14	13	12	11	10	9	8	7	6	5	4	3	2	1	0	
	reserved											S5	S4	S3	S2	S1	S0
Type	RO	RO	RO	RO	RO	RO	RO	RO	RO	RO	R/W	R/W	R/W	R/W	R/W	R/W	
Reset	0	0	0	0	0	0	0	0	0	0	0	0	0	0	0	0	

Bit/Field	Name	Type	Reset	Description
31:6	reserved	RO	0	Software should not rely on the value of a reserved bit. To provide compatibility with future products, the value of a reserved bit should be preserved across a read-modify-write operation.
5	S5	R/W	0	32/64-Bit Wide General-Purpose Timer 5 Sleep Mode Clock Gating Control Value Description 1 Enable and provide a clock to 32/64-bit wide general-purpose timer module 5 in sleep mode. 0 32/64-bit wide general-purpose timer module 5 is disabled.
4	S4	R/W	0	32/64-Bit Wide General-Purpose Timer 4 Sleep Mode Clock Gating Control Value Description 1 Enable and provide a clock to 32/64-bit wide general-purpose timer module 4 in sleep mode. 0 32/64-bit wide general-purpose timer module 4 is disabled.
3	S3	R/W	0	32/64-Bit Wide General-Purpose Timer 3 Sleep Mode Clock Gating Control Value Description 1 Enable and provide a clock to 32/64-bit wide general-purpose timer module 3 in sleep mode. 0 32/64-bit wide general-purpose timer module 3 is disabled.

Bit/Field	Name	Type	Reset	Description
2	S2	R/W	0	32/64-Bit Wide General-Purpose Timer 2 Sleep Mode Clock Gating Control Value Description 1 Enable and provide a clock to 32/64-bit wide general-purpose timer module 2 in sleep mode. 0 32/64-bit wide general-purpose timer module 2 is disabled.
1	S1	R/W	0	32/64-Bit Wide General-Purpose Timer 1 Sleep Mode Clock Gating Control Value Description 1 Enable and provide a clock to 32/64-bit wide general-purpose timer module 1 in sleep mode. 0 32/64-bit wide general-purpose timer module 1 is disabled.
0	S0	R/W	0	32/64-Bit Wide General-Purpose Timer 0 Sleep Mode Clock Gating Control Value Description 1 Enable and provide a clock to 32/64-bit wide general-purpose timer module 0 in sleep mode. 0 32/64-bit wide general-purpose timer module 0 is disabled.

Register 79: Watchdog Timer Deep-Sleep Mode Clock Gating Control (DCGCWD), offset 0x800

The **DCGCWD** register provides software the capability to enable and disable watchdog modules in deep-sleep mode. When enabled, a module is provided a clock. When disabled, the clock is disabled to save power. This register provides the same capability as the legacy **Deep-Sleep Mode Clock Gating Control Register n DCGCn** registers specifically for the watchdog modules and has the same bit polarity as the corresponding **DCGCn** bits.

Important: This register should be used to control the clocking for the watchdog modules. To support legacy software, the **DCGC0** register is available. A write to the **DCGC0** register also writes the corresponding bit in this register. Any bits that are changed by writing to the **DCGC0** register can be read back correctly with a read of the **DCGC0** register. If software uses this register to write a legacy peripheral (such as Watchdog 0), the write causes proper operation, but the value of that bit is not reflected in the **DCGC0** register. If software uses both legacy and peripheral-specific register accesses, the peripheral-specific registers must be accessed by read-modify-write operations that affect only peripherals that are not present in the legacy registers. In this manner, both the peripheral-specific and legacy registers have coherent information.

Watchdog Timer Deep-Sleep Mode Clock Gating Control (DCGCWD)

Base 0x400F.E000
 Offset 0x800
 Type R/W, reset 0x0000.0000

	31	30	29	28	27	26	25	24	23	22	21	20	19	18	17	16	
	reserved																
Type	RO	RO	RO	RO	RO	RO	RO	RO	RO	RO	RO	RO	RO	RO	RO	RO	
Reset	0	0	0	0	0	0	0	0	0	0	0	0	0	0	0	0	
	15	14	13	12	11	10	9	8	7	6	5	4	3	2	1	0	
	reserved															D1	D0
Type	RO	RO	RO	RO	RO	RO	RO	RO	RO	RO	RO	RO	RO	RO	R/W	R/W	
Reset	0	0	0	0	0	0	0	0	0	0	0	0	0	0	0	0	

Bit/Field	Name	Type	Reset	Description
31:2	reserved	RO	0	Software should not rely on the value of a reserved bit. To provide compatibility with future products, the value of a reserved bit should be preserved across a read-modify-write operation.
1	D1	R/W	0	Watchdog Timer 1 Deep-Sleep Mode Clock Gating Control
				Value Description
				1 Enable and provide a clock to Watchdog module 1 in deep-sleep mode.
				0 Watchdog module 1 is disabled.
0	D0	R/W	0	Watchdog Timer 0 Deep-Sleep Mode Clock Gating Control
				Value Description
				1 Enable and provide a clock to Watchdog module 0 in deep-sleep mode.
				0 Watchdog module 0 is disabled.

Register 80: 16/32-Bit General-Purpose Timer Deep-Sleep Mode Clock Gating Control (DCGCTIMER), offset 0x804

The **DCGCTIMER** register provides software the capability to enable and disable 16/32-bit timer modules in deep-sleep mode. When enabled, a module is provided a clock. When disabled, the clock is disabled to save power. This register provides the same capability as the legacy **Deep-Sleep Mode Clock Gating Control Register n DCGCn** registers specifically for the timer modules and has the same bit polarity as the corresponding **DCGCn** bits.

Important: This register should be used to control the clocking for the timer modules. To support legacy software, the **DCGC1** register is available. A write to the **DCGC1** register also writes the corresponding bit in this register. Any bits that are changed by writing to the **DCGC1** register can be read back correctly with a read of the **DCGC1** register. Software must use this register to support modules that are not present in the legacy registers. If software uses this register to write a legacy peripheral (such as Timer 0), the write causes proper operation, but the value of that bit is not reflected in the **DCGC1** register. If software uses both legacy and peripheral-specific register accesses, the peripheral-specific registers must be accessed by read-modify-write operations that affect only peripherals that are not present in the legacy registers. In this manner, both the peripheral-specific and legacy registers have coherent information.

16/32-Bit General-Purpose Timer Deep-Sleep Mode Clock Gating Control (DCGCTIMER)

Base 0x400F.E000

Offset 0x804

Type R/W, reset 0x0000.0000

	31	30	29	28	27	26	25	24	23	22	21	20	19	18	17	16	
	reserved																
Type	RO	RO	RO	RO	RO	RO	RO	RO	RO	RO	RO	RO	RO	RO	RO	RO	
Reset	0	0	0	0	0	0	0	0	0	0	0	0	0	0	0	0	
	15	14	13	12	11	10	9	8	7	6	5	4	3	2	1	0	
	reserved											D5	D4	D3	D2	D1	D0
Type	RO	RO	RO	RO	RO	RO	RO	RO	RO	RO	R/W	R/W	R/W	R/W	R/W	R/W	
Reset	0	0	0	0	0	0	0	0	0	0	0	0	0	0	0	0	

Bit/Field	Name	Type	Reset	Description
31:6	reserved	RO	0	Software should not rely on the value of a reserved bit. To provide compatibility with future products, the value of a reserved bit should be preserved across a read-modify-write operation.
5	D5	R/W	0	16/32-Bit General-Purpose Timer 5 Deep-Sleep Mode Clock Gating Control
				Value Description
			1	Enable and provide a clock to 16/32-bit general-purpose timer module 5 in deep-sleep mode.
			0	16/32-bit general-purpose timer module 5 is disabled.

Bit/Field	Name	Type	Reset	Description
4	D4	R/W	0	<p>16/32-Bit General-Purpose Timer 4 Deep-Sleep Mode Clock Gating Control</p> <p>Value Description</p> <p>1 Enable and provide a clock to 16/32-bit general-purpose timer module 4 in deep-sleep mode.</p> <p>0 16/32-bit general-purpose timer module 4 is disabled.</p>
3	D3	R/W	0	<p>16/32-Bit General-Purpose Timer 3 Deep-Sleep Mode Clock Gating Control</p> <p>Value Description</p> <p>1 Enable and provide a clock to 16/32-bit general-purpose timer module 3 in deep-sleep mode.</p> <p>0 16/32-bit general-purpose timer module 3 is disabled.</p>
2	D2	R/W	0	<p>16/32-Bit General-Purpose Timer 2 Deep-Sleep Mode Clock Gating Control</p> <p>Value Description</p> <p>1 Enable and provide a clock to 16/32-bit general-purpose timer module 2 in deep-sleep mode.</p> <p>0 16/32-bit general-purpose timer module 2 is disabled.</p>
1	D1	R/W	0	<p>16/32-Bit General-Purpose Timer 1 Deep-Sleep Mode Clock Gating Control</p> <p>Value Description</p> <p>1 Enable and provide a clock to 16/32-bit general-purpose timer module 1 in deep-sleep mode.</p> <p>0 16/32-bit general-purpose timer module 1 is disabled.</p>
0	D0	R/W	0	<p>16/32-Bit General-Purpose Timer 0 Deep-Sleep Mode Clock Gating Control</p> <p>Value Description</p> <p>1 Enable and provide a clock to 16/32-bit general-purpose timer module 0 in deep-sleep mode.</p> <p>0 16/32-bit general-purpose timer module 0 is disabled.</p>

Register 81: General-Purpose Input/Output Deep-Sleep Mode Clock Gating Control (DCGCGPIO), offset 0x808

The **DCGCGPIO** register provides software the capability to enable and disable GPIO modules in deep-sleep mode. When enabled, a module is provided a clock. When disabled, the clock is disabled to save power. This register provides the same capability as the legacy **Deep-Sleep Mode Clock Gating Control Register n DCGCn** registers specifically for the watchdog modules and has the same bit polarity as the corresponding **DCGCn** bits.

Important: This register should be used to control the clocking for the GPIO modules. To support legacy software, the **DCGC2** register is available. A write to the **DCGC2** register also writes the corresponding bit in this register. Any bits that are changed by writing to the **DCGC2** register can be read back correctly with a read of the **DCGC2** register. Software must use this register to support modules that are not present in the legacy registers. If software uses this register to write a legacy peripheral (such as GPIO A), the write causes proper operation, but the value of that bit is not reflected in the **DCGC2** register. If software uses both legacy and peripheral-specific register accesses, the peripheral-specific registers must be accessed by read-modify-write operations that affect only peripherals that are not present in the legacy registers. In this manner, both the peripheral-specific and legacy registers have coherent information.

General-Purpose Input/Output Deep-Sleep Mode Clock Gating Control (DCGCGPIO)

Base 0x400F.E000
Offset 0x808
Type R/W, reset 0x0000.0000

	31	30	29	28	27	26	25	24	23	22	21	20	19	18	17	16	
	reserved																
Type	RO	RO	RO	RO	RO	RO	RO	RO	RO	RO	RO	RO	RO	RO	RO	RO	
Reset	0	0	0	0	0	0	0	0	0	0	0	0	0	0	0	0	
	15	14	13	12	11	10	9	8	7	6	5	4	3	2	1	0	
	reserved										D6	D5	D4	D3	D2	D1	D0
Type	RO	RO	RO	RO	RO	RO	RO	RO	RO	R/W	R/W	R/W	R/W	R/W	R/W	R/W	
Reset	0	0	0	0	0	0	0	0	0	0	0	0	0	0	0	0	

Bit/Field	Name	Type	Reset	Description
31:7	reserved	RO	0	Software should not rely on the value of a reserved bit. To provide compatibility with future products, the value of a reserved bit should be preserved across a read-modify-write operation.
6	D6	R/W	0	GPIO Port G Deep-Sleep Mode Clock Gating Control Value Description 1 Enable and provide a clock to GPIO Port G in deep-sleep mode. 0 GPIO Port G is disabled.
5	D5	R/W	0	GPIO Port F Deep-Sleep Mode Clock Gating Control Value Description 1 Enable and provide a clock to GPIO Port F in deep-sleep mode. 0 GPIO Port F is disabled.

Bit/Field	Name	Type	Reset	Description
4	D4	R/W	0	GPIO Port E Deep-Sleep Mode Clock Gating Control Value Description 1 Enable and provide a clock to GPIO Port E in deep-sleep mode. 0 GPIO Port E is disabled.
3	D3	R/W	0	GPIO Port D Deep-Sleep Mode Clock Gating Control Value Description 1 Enable and provide a clock to GPIO Port D in deep-sleep mode. 0 GPIO Port D is disabled.
2	D2	R/W	0	GPIO Port C Deep-Sleep Mode Clock Gating Control Value Description 1 Enable and provide a clock to GPIO Port C in deep-sleep mode. 0 GPIO Port C is disabled.
1	D1	R/W	0	GPIO Port B Deep-Sleep Mode Clock Gating Control Value Description 1 Enable and provide a clock to GPIO Port B in deep-sleep mode. 0 GPIO Port B is disabled.
0	D0	R/W	0	GPIO Port A Deep-Sleep Mode Clock Gating Control Value Description 1 Enable and provide a clock to GPIO Port A in deep-sleep mode. 0 GPIO Port A is disabled.

Register 82: Micro Direct Memory Access Deep-Sleep Mode Clock Gating Control (DCGCDMA), offset 0x80C

The **DCGCDMA** register provides software the capability to enable and disable the μ DMA module in deep-sleep mode. When enabled, a module is provided a clock. When disabled, the clock is disabled to save power. This register provides the same capability as the legacy **Deep-Sleep Mode Clock Gating Control Register n DCGCn** registers specifically for the watchdog modules and has the same bit polarity as the corresponding **DCGCn** bits.

Important: This register should be used to control the clocking for the μ DMA module. To support legacy software, the **DCGC2** register is available. A write to the **UDMA** bit in the **DCGC2** register also writes the **D0** bit in this register. If the **UDMA** bit is changed by writing to the **DCGC2** register, it can be read back correctly with a read of the **DCGC2** register. If software uses this register to control the clock for the μ DMA module, the write causes proper operation, but the **UDMA** bit in the **DCGC2** register does not reflect the value of the **D0** bit. If software uses both legacy and peripheral-specific register accesses, the peripheral-specific registers must be accessed by read-modify-write operations that affect only peripherals that are not present in the legacy registers. In this manner, both the peripheral-specific and legacy registers have coherent information.

Micro Direct Memory Access Deep-Sleep Mode Clock Gating Control (DCGCDMA)

Base 0x400F.E000

Offset 0x80C

Type R/W, reset 0x0000.0000

	31	30	29	28	27	26	25	24	23	22	21	20	19	18	17	16
	reserved															
Type	RO	RO	RO	RO	RO	RO	RO	RO	RO	RO	RO	RO	RO	RO	RO	RO
Reset	0	0	0	0	0	0	0	0	0	0	0	0	0	0	0	0
	15	14	13	12	11	10	9	8	7	6	5	4	3	2	1	0
	reserved															D0
Type	RO	RO	RO	RO	RO	RO	RO	RO	RO	RO	RO	RO	RO	RO	RO	R/W
Reset	0	0	0	0	0	0	0	0	0	0	0	0	0	0	0	0

Bit/Field	Name	Type	Reset	Description
31:1	reserved	RO	0	Software should not rely on the value of a reserved bit. To provide compatibility with future products, the value of a reserved bit should be preserved across a read-modify-write operation.
0	D0	R/W	0	μ DMA Module Deep-Sleep Mode Clock Gating Control
				Value Description
				1 Enable and provide a clock to the μ DMA module in deep-sleep mode.
				0 μ DMA module is disabled.

Register 83: Universal Asynchronous Receiver/Transmitter Deep-Sleep Mode Clock Gating Control (DCGCUART), offset 0x818

The **DCGCUART** register provides software the capability to enable and disable the UART modules in deep-sleep mode. When enabled, a module is provided a clock. When disabled, the clock is disabled to save power. This register provides the same capability as the legacy **Deep-Sleep Mode Clock Gating Control Register n DCGCn** registers specifically for the watchdog modules and has the same bit polarity as the corresponding **DCGCn** bits.

Important: This register should be used to control the clocking for the UART modules. To support legacy software, the **DCGC1** register is available. A write to the **DCGC1** register also writes the corresponding bit in this register. Any bits that are changed by writing to the **DCGC1** register can be read back correctly with a read of the **DCGC1** register. Software must use this register to support modules that are not present in the legacy registers. If software uses this register to write a legacy peripheral (such as UART0), the write causes proper operation, but the value of that bit is not reflected in the **DCGC1** register. If software uses both legacy and peripheral-specific register accesses, the peripheral-specific registers must be accessed by read-modify-write operations that affect only peripherals that are not present in the legacy registers. In this manner, both the peripheral-specific and legacy registers have coherent information.

Universal Asynchronous Receiver/Transmitter Deep-Sleep Mode Clock Gating Control (DCGCUART)

Base 0x400F.E000
 Offset 0x818
 Type R/W, reset 0x0000.0000

	31	30	29	28	27	26	25	24	23	22	21	20	19	18	17	16
	reserved															
Type	RO	RO	RO	RO	RO	RO	RO	RO	RO	RO	RO	RO	RO	RO	RO	RO
Reset	0	0	0	0	0	0	0	0	0	0	0	0	0	0	0	0
	15	14	13	12	11	10	9	8	7	6	5	4	3	2	1	0
	reserved								D7	D6	D5	D4	D3	D2	D1	D0
Type	RO	RO	RO	RO	RO	RO	RO	RO	R/W	R/W	R/W	R/W	R/W	R/W	R/W	R/W
Reset	0	0	0	0	0	0	0	0	0	0	0	0	0	0	0	0

Bit/Field	Name	Type	Reset	Description
31:8	reserved	RO	0	Software should not rely on the value of a reserved bit. To provide compatibility with future products, the value of a reserved bit should be preserved across a read-modify-write operation.
7	D7	R/W	0	UART Module 7 Deep-Sleep Mode Clock Gating Control Value Description 1 Enable and provide a clock to UART module 7 in deep-sleep mode. 0 UART module 7 is disabled.
6	D6	R/W	0	UART Module 6 Deep-Sleep Mode Clock Gating Control Value Description 1 Enable and provide a clock to UART module 6 in deep-sleep mode. 0 UART module 6 is disabled.

Bit/Field	Name	Type	Reset	Description
5	D5	R/W	0	UART Module 5 Deep-Sleep Mode Clock Gating Control Value Description 1 Enable and provide a clock to UART module 5 in deep-sleep mode. 0 UART module 5 is disabled.
4	D4	R/W	0	UART Module 4 Deep-Sleep Mode Clock Gating Control Value Description 1 Enable and provide a clock to UART module 4 in deep-sleep mode. 0 UART module 4 is disabled.
3	D3	R/W	0	UART Module 3 Deep-Sleep Mode Clock Gating Control Value Description 1 Enable and provide a clock to UART module 3 in deep-sleep mode. 0 UART module 3 is disabled.
2	D2	R/W	0	UART Module 2 Deep-Sleep Mode Clock Gating Control Value Description 1 Enable and provide a clock to UART module 2 in deep-sleep mode. 0 UART module 2 is disabled.
1	D1	R/W	0	UART Module 1 Deep-Sleep Mode Clock Gating Control Value Description 1 Enable and provide a clock to UART module 1 in deep-sleep mode. 0 UART module 1 is disabled.
0	D0	R/W	0	UART Module 0 Deep-Sleep Mode Clock Gating Control Value Description 1 Enable and provide a clock to UART module 0 in deep-sleep mode. 0 UART module 0 is disabled.

Register 84: Synchronous Serial Interface Deep-Sleep Mode Clock Gating Control (DCGCSSI), offset 0x81C

The **DCGCSSI** register provides software the capability to enable and disable the SSI modules in deep-sleep mode. When enabled, a module is provided a clock. When disabled, the clock is disabled to save power. This register provides the same capability as the legacy **Deep-Sleep Mode Clock Gating Control Register n DCGCn** registers specifically for the watchdog modules and has the same bit polarity as the corresponding **DCGCn** bits.

Important: This register should be used to control the clocking for the SSI modules. To support legacy software, the **DCGC1** register is available. A write to the **DCGC1** register also writes the corresponding bit in this register. Any bits that are changed by writing to the **DCGC1** register can be read back correctly with a read of the **DCGC1** register. Software must use this register to support modules that are not present in the legacy registers. If software uses this register to write a legacy peripheral (such as SSI0), the write causes proper operation, but the value of that bit is not reflected in the **DCGC1** register. If software uses both legacy and peripheral-specific register accesses, the peripheral-specific registers must be accessed by read-modify-write operations that affect only peripherals that are not present in the legacy registers. In this manner, both the peripheral-specific and legacy registers have coherent information.

Synchronous Serial Interface Deep-Sleep Mode Clock Gating Control (DCGCSSI)

Base 0x400F.E000
 Offset 0x81C
 Type R/W, reset 0x0000.0000

	31	30	29	28	27	26	25	24	23	22	21	20	19	18	17	16
	reserved															
Type	RO	RO	RO	RO	RO	RO	RO	RO	RO	RO	RO	RO	RO	RO	RO	RO
Reset	0	0	0	0	0	0	0	0	0	0	0	0	0	0	0	0
	15	14	13	12	11	10	9	8	7	6	5	4	3	2	1	0
	reserved												D3	D2	D1	D0
Type	RO	RO	RO	RO	RO	RO	RO	RO	RO	RO	RO	RO	R/W	R/W	R/W	R/W
Reset	0	0	0	0	0	0	0	0	0	0	0	0	0	0	0	0

Bit/Field	Name	Type	Reset	Description
31:4	reserved	RO	0	Software should not rely on the value of a reserved bit. To provide compatibility with future products, the value of a reserved bit should be preserved across a read-modify-write operation.
3	D3	R/W	0	SSI Module 3 Deep-Sleep Mode Clock Gating Control Value Description 1 Enable and provide a clock to SSI module 3 in deep-sleep mode. 0 SSI module 3 is disabled.
2	D2	R/W	0	SSI Module 2 Deep-Sleep Mode Clock Gating Control Value Description 1 Enable and provide a clock to SSI module 2 in deep-sleep mode. 0 SSI module 2 is disabled.

Bit/Field	Name	Type	Reset	Description
1	D1	R/W	0	SSI Module 1 Deep-Sleep Mode Clock Gating Control Value Description 1 Enable and provide a clock to SSI module 1 in deep-sleep mode. 0 SSI module 1 is disabled.
0	D0	R/W	0	SSI Module 0 Deep-Sleep Mode Clock Gating Control Value Description 1 Enable and provide a clock to SSI module 0 in deep-sleep mode. 0 SSI module 0 is disabled.

Register 85: Inter-Integrated Circuit Deep-Sleep Mode Clock Gating Control (DCGCI2C), offset 0x820

The **DCGCI2C** register provides software the capability to enable and disable the I²C modules in deep-sleep mode. When enabled, a module is provided a clock. When disabled, the clock is disabled to save power. This register provides the same capability as the legacy **Deep-Sleep Mode Clock Gating Control Register n DCGCn** registers specifically for the watchdog modules and has the same bit polarity as the corresponding **DCGCn** bits.

Important: This register should be used to control the clocking for the I²C modules. To support legacy software, the **DCGC1** register is available. A write to the **DCGC1** register also writes the corresponding bit in this register. Any bits that are changed by writing to the **DCGC1** register can be read back correctly with a read of the **DCGC1** register. Software must use this register to support modules that are not present in the legacy registers. If software uses this register to write a legacy peripheral (such as I²C0), the write causes proper operation, but the value of that bit is not reflected in the **DCGC1** register. If software uses both legacy and peripheral-specific register accesses, the peripheral-specific registers must be accessed by read-modify-write operations that affect only peripherals that are not present in the legacy registers. In this manner, both the peripheral-specific and legacy registers have coherent information.

Inter-Integrated Circuit Deep-Sleep Mode Clock Gating Control (DCGCI2C)

Base 0x400F.E000
 Offset 0x820
 Type R/W, reset 0x0000.0000

	31	30	29	28	27	26	25	24	23	22	21	20	19	18	17	16	
	reserved																
Type	RO	RO	RO	RO	RO	RO	RO	RO	RO	RO	RO	RO	RO	RO	RO	RO	
Reset	0	0	0	0	0	0	0	0	0	0	0	0	0	0	0	0	
	15	14	13	12	11	10	9	8	7	6	5	4	3	2	1	0	
	reserved											D5	D4	D3	D2	D1	D0
Type	RO	RO	RO	RO	RO	RO	RO	RO	RO	RO	R/W	R/W	R/W	R/W	R/W	R/W	
Reset	0	0	0	0	0	0	0	0	0	0	0	0	0	0	0	0	

Bit/Field	Name	Type	Reset	Description
31:6	reserved	RO	0	Software should not rely on the value of a reserved bit. To provide compatibility with future products, the value of a reserved bit should be preserved across a read-modify-write operation.
5	D5	R/W	0	I ² C Module 5 Deep-Sleep Mode Clock Gating Control Value Description 1 Enable and provide a clock to I ² C module 5 in deep-sleep mode. 0 I ² C module 5 is disabled.
4	D4	R/W	0	I ² C Module 4 Deep-Sleep Mode Clock Gating Control Value Description 1 Enable and provide a clock to I ² C module 4 in deep-sleep mode. 0 I ² C module 4 is disabled.

Bit/Field	Name	Type	Reset	Description
3	D3	R/W	0	I ² C Module 3 Deep-Sleep Mode Clock Gating Control Value Description 1 Enable and provide a clock to I ² C module 3 in deep-sleep mode. 0 I ² C module 3 is disabled.
2	D2	R/W	0	I ² C Module 2 Deep-Sleep Mode Clock Gating Control Value Description 1 Enable and provide a clock to I ² C module 2 in deep-sleep mode. 0 I ² C module 2 is disabled.
1	D1	R/W	0	I ² C Module 1 Deep-Sleep Mode Clock Gating Control Value Description 1 Enable and provide a clock to I ² C module 1 in deep-sleep mode. 0 I ² C module 1 is disabled.
0	D0	R/W	0	I ² C Module 0 Deep-Sleep Mode Clock Gating Control Value Description 1 Enable and provide a clock to I ² C module 0 in deep-sleep mode. 0 I ² C module 0 is disabled.

Register 86: Universal Serial Bus Deep-Sleep Mode Clock Gating Control (DCGCUSB), offset 0x828

The **DCGCUSB** register provides software the capability to enable and disable the USB module in deep-sleep mode. When enabled, a module is provided a clock. When disabled, the clock is disabled to save power. This register provides the same capability as the legacy **Deep-Sleep Mode Clock Gating Control Register n DCGCn** registers specifically for the watchdog modules and has the same bit polarity as the corresponding **DCGCn** bits.

Important: This register should be used to control the clocking for the USB module. To support legacy software, the **DCGC2** register is available. A write to the **USB0** bit in the **DCGC2** register also writes the **D0** bit in this register. If the **USB0** bit is changed by writing to the **DCGC2** register, it can be read back correctly with a read of the **DCGC2** register. If software uses this register to control the clock for the USB module, the write causes proper operation, but the **USB0** bit in the **DCGC2** register does not reflect the value of the **D0** bit. If software uses both legacy and peripheral-specific register accesses, the peripheral-specific registers must be accessed by read-modify-write operations that affect only peripherals that are not present in the legacy registers. In this manner, both the peripheral-specific and legacy registers have coherent information.

Universal Serial Bus Deep-Sleep Mode Clock Gating Control (DCGCUSB)

Base 0x400F.E000
 Offset 0x828
 Type R/W, reset 0x0000.0000

	31	30	29	28	27	26	25	24	23	22	21	20	19	18	17	16
	reserved															
Type	RO	RO	RO	RO	RO	RO	RO	RO	RO	RO	RO	RO	RO	RO	RO	RO
Reset	0	0	0	0	0	0	0	0	0	0	0	0	0	0	0	0
	15	14	13	12	11	10	9	8	7	6	5	4	3	2	1	0
	reserved															D0
Type	RO	RO	RO	RO	RO	RO	RO	RO	RO	RO	RO	RO	RO	RO	RO	R/W
Reset	0	0	0	0	0	0	0	0	0	0	0	0	0	0	0	0

Bit/Field	Name	Type	Reset	Description
31:1	reserved	RO	0	Software should not rely on the value of a reserved bit. To provide compatibility with future products, the value of a reserved bit should be preserved across a read-modify-write operation.
0	D0	R/W	0	USB Module Deep-Sleep Mode Clock Gating Control
				Value Description
				1 Enable and provide a clock to the USB module in deep-sleep mode.
				0 USB module is disabled.

Register 87: Controller Area Network Deep-Sleep Mode Clock Gating Control (DCGCCAN), offset 0x834

The **DCGCCAN** register provides software the capability to enable and disable the CAN modules in deep-sleep mode. When enabled, a module is provided a clock. When disabled, the clock is disabled to save power. This register provides the same capability as the legacy **Deep-Sleep Mode Clock Gating Control Register n DCGCn** registers specifically for the watchdog modules and has the same bit polarity as the corresponding **DCGCn** bits.

Important: This register should be used to control the clocking for the CAN modules. To support legacy software, the **DCGC0** register is available. A write to the **DCGC0** register also writes the corresponding bit in this register. Any bits that are changed by writing to the **DCGC0** register can be read back correctly with a read of the **DCGC0** register. If software uses this register to write a legacy peripheral (such as CAN0), the write causes proper operation, but the value of that bit is not reflected in the **DCGC0** register. If software uses both legacy and peripheral-specific register accesses, the peripheral-specific registers must be accessed by read-modify-write operations that affect only peripherals that are not present in the legacy registers. In this manner, both the peripheral-specific and legacy registers have coherent information.

Controller Area Network Deep-Sleep Mode Clock Gating Control (DCGCCAN)

Base 0x400F.E000
Offset 0x834
Type R/W, reset 0x0000.0000

	31	30	29	28	27	26	25	24	23	22	21	20	19	18	17	16	
	reserved																
Type	RO	RO	RO	RO	RO	RO	RO	RO	RO	RO	RO	RO	RO	RO	RO	RO	
Reset	0	0	0	0	0	0	0	0	0	0	0	0	0	0	0	0	
	15	14	13	12	11	10	9	8	7	6	5	4	3	2	1	0	
	reserved															D1	D0
Type	RO	RO	RO	RO	RO	RO	RO	RO	RO	RO	RO	RO	RO	RO	R/W	R/W	
Reset	0	0	0	0	0	0	0	0	0	0	0	0	0	0	0	0	

Bit/Field	Name	Type	Reset	Description
31:2	reserved	RO	0	Software should not rely on the value of a reserved bit. To provide compatibility with future products, the value of a reserved bit should be preserved across a read-modify-write operation.
1	D1	R/W	0	CAN Module 1 Deep-Sleep Mode Clock Gating Control Value Description 1 Enable and provide a clock to CAN module 1 in deep-sleep mode. 0 CAN module 1 is disabled.
0	D0	R/W	0	CAN Module 0 Deep-Sleep Mode Clock Gating Control Value Description 1 Enable and provide a clock to CAN module 0 in deep-sleep mode. 0 CAN module 0 is disabled.

Register 88: Analog-to-Digital Converter Deep-Sleep Mode Clock Gating Control (DCGCADC), offset 0x838

The **DCGCADC** register provides software the capability to enable and disable the ADC modules in deep-sleep mode. When enabled, a module is provided a clock. When disabled, the clock is disabled to save power. This register provides the same capability as the legacy **Deep-Sleep Mode Clock Gating Control Register n DCGCn** registers specifically for the watchdog modules and has the same bit polarity as the corresponding **DCGCn** bits.

Important: This register should be used to control the clocking for the ADC modules. To support legacy software, the **DCGC0** register is available. A write to the **DCGC0** register also writes the corresponding bit in this register. Any bits that are changed by writing to the **DCGC0** register can be read back correctly with a read of the **DCGC0** register. If software uses this register to write a legacy peripheral (such as ADC0), the write causes proper operation, but the value of that bit is not reflected in the **DCGC0** register. If software uses both legacy and peripheral-specific register accesses, the peripheral-specific registers must be accessed by read-modify-write operations that affect only peripherals that are not present in the legacy registers. In this manner, both the peripheral-specific and legacy registers have coherent information.

Analog-to-Digital Converter Deep-Sleep Mode Clock Gating Control (DCGCADC)

Base 0x400F.E000
 Offset 0x838
 Type R/W, reset 0x0000.0000

	31	30	29	28	27	26	25	24	23	22	21	20	19	18	17	16	
	reserved																
Type	RO	RO	RO	RO	RO	RO	RO	RO	RO	RO	RO	RO	RO	RO	RO	RO	
Reset	0	0	0	0	0	0	0	0	0	0	0	0	0	0	0	0	
	15	14	13	12	11	10	9	8	7	6	5	4	3	2	1	0	
	reserved															D1	D0
Type	RO	RO	RO	RO	RO	RO	RO	RO	RO	RO	RO	RO	RO	RO	R/W	R/W	
Reset	0	0	0	0	0	0	0	0	0	0	0	0	0	0	0	0	

Bit/Field	Name	Type	Reset	Description
31:2	reserved	RO	0	Software should not rely on the value of a reserved bit. To provide compatibility with future products, the value of a reserved bit should be preserved across a read-modify-write operation.
1	D1	R/W	0	ADC Module 1 Deep-Sleep Mode Clock Gating Control Value Description 1 Enable and provide a clock to ADC module 1 in deep-sleep mode. 0 ADC module 1 is disabled.
0	D0	R/W	0	ADC Module 0 Deep-Sleep Mode Clock Gating Control Value Description 1 Enable and provide a clock to ADC module 0 in deep-sleep mode. 0 ADC module 0 is disabled.

Register 89: Analog Comparator Deep-Sleep Mode Clock Gating Control (DCGCACMP), offset 0x83C

The **DCGCACMP** register provides software the capability to enable and disable the analog comparator module in deep-sleep mode. When enabled, a module is provided a clock. When disabled, the clock is disabled to save power. This register provides the same capability as the legacy **Deep-Sleep Mode Clock Gating Control Register n DCGCn** registers specifically for the watchdog modules and has the same bit polarity as the corresponding **DCGCn** bits.

Important: This register should be used to control the clocking for the analog comparator module. To support legacy software, the **DCGC1** register is available. Setting any of the **COMPn** bits in the **DCGC1** register also sets the **D0** bit in this register. If any of the **COMPn** bits are set by writing to the **DCGC1** register, it can be read back correctly when reading the **DCGC1** register. If software uses this register to change the clocking for the analog comparator module, the write causes proper operation, but the value **D0** is not reflected by the **COMPn** bits in the **DCGC1** register. If software uses both legacy and peripheral-specific register accesses, the peripheral-specific registers must be accessed by read-modify-write operations that affect only peripherals that are not present in the legacy registers. In this manner, both the peripheral-specific and legacy registers have coherent information.

Analog Comparator Deep-Sleep Mode Clock Gating Control (DCGCACMP)

Base 0x400F.E000
Offset 0x83C
Type R/W, reset 0x0000.0000

	31	30	29	28	27	26	25	24	23	22	21	20	19	18	17	16
	reserved															
Type	RO	RO	RO	RO	RO	RO	RO	RO	RO	RO	RO	RO	RO	RO	RO	RO
Reset	0	0	0	0	0	0	0	0	0	0	0	0	0	0	0	0
	15	14	13	12	11	10	9	8	7	6	5	4	3	2	1	0
	reserved															D0
Type	RO	RO	RO	RO	RO	RO	RO	RO	RO	RO	RO	RO	RO	RO	RO	R/W
Reset	0	0	0	0	0	0	0	0	0	0	0	0	0	0	0	0

Bit/Field	Name	Type	Reset	Description
31:1	reserved	RO	0	Software should not rely on the value of a reserved bit. To provide compatibility with future products, the value of a reserved bit should be preserved across a read-modify-write operation.
0	D0	R/W	0	Analog Comparator Module 0 Deep-Sleep Mode Clock Gating Control
				Value Description
				1 Enable and provide a clock to the analog comparator module in deep-sleep mode.
				0 Analog comparator module is disabled.

Register 90: Pulse Width Modulator Deep-Sleep Mode Clock Gating Control (DCGCPWM), offset 0x840

The **DCGCPWM** register provides software the capability to enable and disable the PWM modules in deep-sleep mode. When enabled, a module is provided a clock. When disabled, the clock is disabled to save power. This register provides the same capability as the legacy **Deep-Sleep Mode Clock Gating Control Register n DCGCn** registers specifically for the watchdog modules and has the same bit polarity as the corresponding **DCGCn** bits.

Important: This register should be used to control the clocking for the PWM modules. To support legacy software, the **DCGC0** register is available. A write to the **PWM** bit in the **DCGC0** register also writes the **D0** bit in this register. If the **PWM** bit is changed by writing to the **DCGC0** register, it can be read back correctly with a read of the **DCGC0** register. Software must use this register to support modules that are not present in the legacy registers. If software uses this register to write to **D0**, the write causes proper operation, but the value of that bit is not reflected in the **PWM** bit in the **DCGC0** register. If software uses both legacy and peripheral-specific register accesses, the peripheral-specific registers must be accessed by read-modify-write operations that affect only peripherals that are not present in the legacy registers. In this manner, both the peripheral-specific and legacy registers have coherent information.

Pulse Width Modulator Deep-Sleep Mode Clock Gating Control (DCGCPWM)

Base 0x400F.E000
 Offset 0x840
 Type R/W, reset 0x0000.0000

	31	30	29	28	27	26	25	24	23	22	21	20	19	18	17	16	
	reserved																
Type	RO	RO	RO	RO	RO	RO	RO	RO	RO	RO	RO	RO	RO	RO	RO	RO	
Reset	0	0	0	0	0	0	0	0	0	0	0	0	0	0	0	0	
	15	14	13	12	11	10	9	8	7	6	5	4	3	2	1	0	
	reserved															D1	D0
Type	RO	RO	RO	RO	RO	RO	RO	RO	RO	RO	RO	RO	RO	RO	R/W	R/W	
Reset	0	0	0	0	0	0	0	0	0	0	0	0	0	0	0	0	

Bit/Field	Name	Type	Reset	Description
31:2	reserved	RO	0	Software should not rely on the value of a reserved bit. To provide compatibility with future products, the value of a reserved bit should be preserved across a read-modify-write operation.
1	D1	R/W	0	PWM Module 1 Deep-Sleep Mode Clock Gating Control Value Description 1 Enable and provide a clock to PWM module 1 in deep-sleep mode. 0 PWM module 1 is disabled.
0	D0	R/W	0	PWM Module 0 Deep-Sleep Mode Clock Gating Control Value Description 1 Enable and provide a clock to PWM module 0 in deep-sleep mode. 0 PWM module 0 is disabled.

Register 91: Quadrature Encoder Interface Deep-Sleep Mode Clock Gating Control (DCGCQEI), offset 0x844

The **DCGCQEI** register provides software the capability to enable and disable the QEI modules in deep-sleep mode. When enabled, a module is provided a clock. When disabled, the clock is disabled to save power. This register provides the same capability as the legacy **Deep-Sleep Mode Clock Gating Control Register n DCGCn** registers specifically for the watchdog modules and has the same bit polarity as the corresponding **DCGCn** bits.

Important: This register should be used to control the clocking for the QEI modules. To support legacy software, the **DCGC1** register is available. A write to the **DCGC1** register also writes the corresponding bit in this register. Any bits that are changed by writing to the **DCGC1** register can be read back correctly with a read of the **DCGC1** register. If software uses this register to write a legacy peripheral (such as QEI0), the write causes proper operation, but the value of that bit is not reflected in the **DCGC1** register. If software uses both legacy and peripheral-specific register accesses, the peripheral-specific registers must be accessed by read-modify-write operations that affect only peripherals that are not present in the legacy registers. In this manner, both the peripheral-specific and legacy registers have coherent information.

Quadrature Encoder Interface Deep-Sleep Mode Clock Gating Control (DCGCQEI)

Base 0x400F.E000
Offset 0x844
Type R/W, reset 0x0000.0000

	31	30	29	28	27	26	25	24	23	22	21	20	19	18	17	16	
	reserved																
Type	RO	RO	RO	RO	RO	RO	RO	RO	RO	RO	RO	RO	RO	RO	RO	RO	
Reset	0	0	0	0	0	0	0	0	0	0	0	0	0	0	0	0	
	15	14	13	12	11	10	9	8	7	6	5	4	3	2	1	0	
	reserved															D1	D0
Type	RO	RO	RO	RO	RO	RO	RO	RO	RO	RO	RO	RO	RO	RO	R/W	R/W	
Reset	0	0	0	0	0	0	0	0	0	0	0	0	0	0	0	0	

Bit/Field	Name	Type	Reset	Description
31:2	reserved	RO	0	Software should not rely on the value of a reserved bit. To provide compatibility with future products, the value of a reserved bit should be preserved across a read-modify-write operation.
1	D1	R/W	0	QEI Module 1 Deep-Sleep Mode Clock Gating Control Value Description 1 Enable and provide a clock to QEI module 1 in deep-sleep mode. 0 QEI module 1 is disabled.
0	D0	R/W	0	QEI Module 0 Deep-Sleep Mode Clock Gating Control Value Description 1 Enable and provide a clock to QEI module 0 in deep-sleep mode. 0 QEI module 0 is disabled.

Register 92: EEPROM Deep-Sleep Mode Clock Gating Control (DCGCEEPROM), offset 0x858

The **DCGCEEPROM** register provides software the capability to enable and disable the EEPROM module in deep-sleep mode. When enabled, a module is provided a clock. When disabled, the clock is disabled to save power.

EEPROM Deep-Sleep Mode Clock Gating Control (DCGCEEPROM)

Base 0x400F.E000
 Offset 0x858
 Type R/W, reset 0x0000.0000

	31	30	29	28	27	26	25	24	23	22	21	20	19	18	17	16
	reserved															
Type	RO	RO	RO	RO	RO	RO	RO	RO	RO	RO	RO	RO	RO	RO	RO	RO
Reset	0	0	0	0	0	0	0	0	0	0	0	0	0	0	0	0
	15	14	13	12	11	10	9	8	7	6	5	4	3	2	1	0
	reserved															
Type	RO	RO	RO	RO	RO	RO	RO	RO	RO	RO	RO	RO	RO	RO	RO	R/W
Reset	0	0	0	0	0	0	0	0	0	0	0	0	0	0	0	0

Bit/Field	Name	Type	Reset	Description
31:1	reserved	RO	0	Software should not rely on the value of a reserved bit. To provide compatibility with future products, the value of a reserved bit should be preserved across a read-modify-write operation.
0	D0	R/W	0	EEPROM Module Deep-Sleep Mode Clock Gating Control
				Value Description
				1 Enable and provide a clock to the EEPROM module in deep-sleep mode.
				0 EEPROM module is disabled.

Register 93: 32/64-Bit Wide General-Purpose Timer Deep-Sleep Mode Clock Gating Control (DCGCWTIMER), offset 0x85C

The **DCGCWTIMER** register provides software the capability to enable and disable 32/64-bit wide timer modules in deep-sleep mode. When enabled, a module is provided a clock. When disabled, the clock is disabled to save power. This register provides the same capability as the legacy **Deep-Sleep Mode Clock Gating Control Register n DCGCn** registers specifically for the timer modules and has the same bit polarity as the corresponding **DCGCn** bits.

32/64-Bit Wide General-Purpose Timer Deep-Sleep Mode Clock Gating Control (DCGCWTIMER)

Base 0x400F.E000
Offset 0x85C
Type R/W, reset 0x0000.0000

	31	30	29	28	27	26	25	24	23	22	21	20	19	18	17	16	
	reserved																
Type	RO	RO	RO	RO	RO	RO	RO	RO	RO	RO	RO	RO	RO	RO	RO	RO	
Reset	0	0	0	0	0	0	0	0	0	0	0	0	0	0	0	0	
	15	14	13	12	11	10	9	8	7	6	5	4	3	2	1	0	
	reserved											D5	D4	D3	D2	D1	D0
Type	RO	RO	RO	RO	RO	RO	RO	RO	RO	RO	R/W	R/W	R/W	R/W	R/W	R/W	
Reset	0	0	0	0	0	0	0	0	0	0	0	0	0	0	0	0	

Bit/Field	Name	Type	Reset	Description
31:6	reserved	RO	0	Software should not rely on the value of a reserved bit. To provide compatibility with future products, the value of a reserved bit should be preserved across a read-modify-write operation.
5	D5	R/W	0	32/64-Bit Wide General-Purpose Timer 5 Deep-Sleep Mode Clock Gating Control Value Description 1 Enable and provide a clock to 32/64-bit wide general-purpose timer module 5 in deep-sleep mode. 0 32/64-bit wide general-purpose timer module 5 is disabled.
4	D4	R/W	0	32/64-Bit Wide General-Purpose Timer 4 Deep-Sleep Mode Clock Gating Control Value Description 1 Enable and provide a clock to 32/64-bit wide general-purpose timer module 4 in deep-sleep mode. 0 32/64-bit wide general-purpose timer module 4 is disabled.
3	D3	R/W	0	32/64-Bit Wide General-Purpose Timer 3 Deep-Sleep Mode Clock Gating Control Value Description 1 Enable and provide a clock to 32/64-bit wide general-purpose timer module 3 in deep-sleep mode. 0 32/64-bit wide general-purpose timer module 3 is disabled.

Bit/Field	Name	Type	Reset	Description
2	D2	R/W	0	32/64-Bit Wide General-Purpose Timer 2 Deep-Sleep Mode Clock Gating Control Value Description 1 Enable and provide a clock to 32/64-bit wide general-purpose timer module 2 in deep-sleep mode. 0 32/64-bit wide general-purpose timer module 2 is disabled.
1	D1	R/W	0	32/64-Bit Wide General-Purpose Timer 1 Deep-Sleep Mode Clock Gating Control Value Description 1 Enable and provide a clock to 32/64-bit wide general-purpose timer module 1 in deep-sleep mode. 0 32/64-bit wide general-purpose timer module 1 is disabled.
0	D0	R/W	0	32/64-Bit Wide General-Purpose Timer 0 Deep-Sleep Mode Clock Gating Control Value Description 1 Enable and provide a clock to 32/64-bit wide general-purpose timer module 0 in deep-sleep mode. 0 32/64-bit wide general-purpose timer module 0 is disabled.

Register 94: Watchdog Timer Power Control (PCWD), offset 0x900

The **PCWD** register controls the power provided to the watchdog modules. Clearing the bit corresponding to one of the modules indicates to the hardware that firmware requests that the peripheral be unpowered. When a bit in this register is set, the corresponding module's state is not retained. Software should perform a peripheral reset using the **SRWD** register if the active mode changes and the corresponding bit in the **RCGCWD**, **SCGCWD**, or **DCGCWD** register is a 1 or the **P_n** bit is changed from a 0 to a 1. Software must re-initialize the module when re-enabled due to the loss of state.

Note: The watchdog modules do not currently have the ability to respond to the power down request. Setting a bit in this register has no effect on power consumption. This register is provided for future software compatibility.

Watchdog Timer Power Control (PCWD)

Base 0x400F.E000
Offset 0x900
Type R/W, reset 0x0000.0003

	31	30	29	28	27	26	25	24	23	22	21	20	19	18	17	16	
	reserved																
Type	RO	RO	RO	RO	RO	RO	RO	RO	RO	RO	RO	RO	RO	RO	RO	RO	
Reset	0	0	0	0	0	0	0	0	0	0	0	0	0	0	0	0	
	15	14	13	12	11	10	9	8	7	6	5	4	3	2	1	0	
	reserved															P1	P0
Type	RO	RO	RO	RO	RO	RO	RO	RO	RO	RO	RO	RO	RO	RO	RO	R/W	R/W
Reset	0	0	0	0	0	0	0	0	0	0	0	0	0	0	0	1	1

Bit/Field	Name	Type	Reset	Description
31:2	reserved	RO	0	Software should not rely on the value of a reserved bit. To provide compatibility with future products, the value of a reserved bit should be preserved across a read-modify-write operation.
1	P1	R/W	1	<p>Watchdog Timer 1 Power Control</p> <p>The value of this bit does not have meaning unless the corresponding, active mode RCGCWD, SCGCWD or DCGCWD bit is cleared.</p> <p>Value Description</p> <p>1 Watchdog module 1 is powered, but does not receive a clock. In this case, the module is inactive. This configuration provides the second-lowest power consumption of the module because it consumes only leakage current.</p> <p>0 Watchdog module 1 is not powered and does not receive a clock. In this case, the module's state is not retained. This configuration provides the lowest power consumption state of the module because it consumes no dynamic nor leakage current.</p>

Bit/Field	Name	Type	Reset	Description
0	P0	R/W	1	<p>Watchdog Timer 0 Power Control</p> <p>The value of this bit does not have meaning unless the corresponding, active mode RCGCWD, SCGCWD or DCGCWD bit is cleared.</p> <p>Value Description</p> <p>1 Watchdog module 0 is powered, but does not receive a clock. In this case, the module is inactive.</p> <p>This configuration provides the second-lowest power consumption of the module because it consumes only leakage current.</p> <p>0 Watchdog module 0 is not powered and does not receive a clock. In this case, the module's state is not retained.</p> <p>This configuration provides the lowest power consumption state of the module because it consumes no dynamic nor leakage current.</p>

Register 95: 16/32-Bit General-Purpose Timer Power Control (PCTIMER), offset 0x904

The **PCTIMER** register controls the power provided to the 16/32-bit timer modules. Clearing the bit corresponding to one of the modules indicates to the hardware that firmware requests that the peripheral be unpowered. When a bit in this register is set, the corresponding modules state is not retained. Software should perform a peripheral reset using the **SRTIMER** register if the active mode changes and the corresponding bit in the **RCGCTIMER**, **SCGCTIMER**, or **DCGCTIMER** register is a 1 or the P_n bit is changed from a 0 to a 1. Software must re-initialize the module when re-enabled due to the loss of state.

Note: The timer modules do not currently have the ability to respond to the power down request. Setting a bit in this register has no effect on power consumption. This register is provided for future software compatibility.

16/32-Bit General-Purpose Timer Power Control (PCTIMER)

Base 0x400F.E000
Offset 0x904
Type R/W, reset 0x0000.003F

	31	30	29	28	27	26	25	24	23	22	21	20	19	18	17	16	
	reserved																
Type	RO	RO	RO	RO	RO	RO	RO	RO	RO	RO	RO	RO	RO	RO	RO	RO	
Reset	0	0	0	0	0	0	0	0	0	0	0	0	0	0	0	0	
	15	14	13	12	11	10	9	8	7	6	5	4	3	2	1	0	
	reserved											P5	P4	P3	P2	P1	P0
Type	RO	RO	RO	RO	RO	RO	RO	RO	RO	RO	R/W	R/W	R/W	R/W	R/W	R/W	
Reset	0	0	0	0	0	0	0	0	0	0	1	1	1	1	1	1	

Bit/Field	Name	Type	Reset	Description
31:6	reserved	RO	0	Software should not rely on the value of a reserved bit. To provide compatibility with future products, the value of a reserved bit should be preserved across a read-modify-write operation.
5	P5	R/W	1	16/32-Bit General-Purpose Timer 5 Power Control The value of this bit does not have meaning unless the corresponding, active mode RCGCTIMER , SCGCTIMER or DCGCTIMER bit is cleared.

Value Description

- | | |
|---|---|
| 1 | Timer module 5 is powered, but does not receive a clock. In this case, the module is inactive.

This configuration provides the second-lowest power consumption of the module because it consumes only leakage current. |
| 0 | Timer module 5 is not powered and does not receive a clock. In this case, the module's state is not retained.

This configuration provides the lowest power consumption state of the module because it consumes no dynamic nor leakage current. |

Bit/Field	Name	Type	Reset	Description
4	P4	R/W	1	<p>16/32-Bit General-Purpose Timer 4 Power Control</p> <p>The value of this bit does not have meaning unless the corresponding, active mode RCGCTIMER, SCGCTIMER or DCGCTIMER bit is cleared.</p> <p>Value Description</p> <p>1 Timer module 4 is powered, but does not receive a clock. In this case, the module is inactive.</p> <p>This configuration provides the second-lowest power consumption of the module because it consumes only leakage current.</p> <p>0 Timer module 4 is not powered and does not receive a clock. In this case, the module's state is not retained.</p> <p>This configuration provides the lowest power consumption state of the module because it consumes no dynamic nor leakage current.</p>
3	P3	R/W	1	<p>16/32-Bit General-Purpose Timer 3 Power Control</p> <p>The value of this bit does not have meaning unless the corresponding, active mode RCGCTIMER, SCGCTIMER or DCGCTIMER bit is cleared.</p> <p>Value Description</p> <p>1 Timer module 3 is powered, but does not receive a clock. In this case, the module is inactive.</p> <p>This configuration provides the second-lowest power consumption of the module because it consumes only leakage current.</p> <p>0 Timer module 3 is not powered and does not receive a clock. In this case, the module's state is not retained.</p> <p>This configuration provides the lowest power consumption state of the module because it consumes no dynamic nor leakage current.</p>
2	P2	R/W	1	<p>16/32-Bit General-Purpose Timer 2 Power Control</p> <p>The value of this bit does not have meaning unless the corresponding, active mode RCGCTIMER, SCGCTIMER or DCGCTIMER bit is cleared.</p> <p>Value Description</p> <p>1 Timer module 2 is powered, but does not receive a clock. In this case, the module is inactive.</p> <p>This configuration provides the second-lowest power consumption of the module because it consumes only leakage current.</p> <p>0 Timer module 2 is not powered and does not receive a clock. In this case, the module's state is not retained.</p> <p>This configuration provides the lowest power consumption state of the module because it consumes no dynamic nor leakage current.</p>

Bit/Field	Name	Type	Reset	Description
1	P1	R/W	1	<p>16/32-Bit General-Purpose Timer 1 Power Control</p> <p>The value of this bit does not have meaning unless the corresponding, active mode RCGCTIMER, SCGCTIMER or DCGCTIMER bit is cleared.</p> <p>Value Description</p> <p>1 Timer module 1 is powered, but does not receive a clock. In this case, the module is inactive.</p> <p>This configuration provides the second-lowest power consumption of the module because it consumes only leakage current.</p> <p>0 Timer module 1 is not powered and does not receive a clock. In this case, the module's state is not retained.</p> <p>This configuration provides the lowest power consumption state of the module because it consumes no dynamic nor leakage current.</p>
0	P0	R/W	1	<p>16/32-Bit General-Purpose Timer 0 Power Control</p> <p>The value of this bit does not have meaning unless the corresponding, active mode RCGCTIMER, SCGCTIMER or DCGCTIMER bit is cleared.</p> <p>Value Description</p> <p>1 Timer module 0 is powered, but does not receive a clock. In this case, the module is inactive.</p> <p>This configuration provides the second-lowest power consumption of the module because it consumes only leakage current.</p> <p>0 Timer module 0 is not powered and does not receive a clock. In this case, the module's state is not retained.</p> <p>This configuration provides the lowest power consumption state of the module because it consumes no dynamic nor leakage current.</p>

Register 96: General-Purpose Input/Output Power Control (PCGPIO), offset 0x908

The **PCGPIO** register controls the power provided to the GPIO modules. Clearing the bit corresponding to one of the modules indicates to the hardware that firmware requests that the peripheral be unpowered. When a bit in this register is set, the corresponding module's state is not retained. Software should perform a peripheral reset using the **SRGPIO** register if the active mode changes and the corresponding bit in the **RCGCGPIO**, **SCGCGPIO**, or **DCGCGPIO** register is a 1 or the P_n bit is changed from a 0 to a 1. Software must re-initialize the module when re-enabled due to the loss of state.

Note: The GPIO modules do not currently have the ability to respond to the power down request. Setting a bit in this register has no effect on power consumption. This register is provided for future software compatibility.

General-Purpose Input/Output Power Control (PCGPIO)

Base 0x400F.E000
 Offset 0x908
 Type R/W, reset 0x0000.7FFF

	31	30	29	28	27	26	25	24	23	22	21	20	19	18	17	16	
	reserved																
Type	RO	RO	RO	RO	RO	RO	RO	RO	RO	RO	RO	RO	RO	RO	RO	RO	
Reset	0	0	0	0	0	0	0	0	0	0	0	0	0	0	0	0	
	15	14	13	12	11	10	9	8	7	6	5	4	3	2	1	0	
	reserved										P6	P5	P4	P3	P2	P1	P0
Type	RO	RO	RO	RO	RO	RO	RO	RO	RO	R/W	R/W	R/W	R/W	R/W	R/W	R/W	
Reset	0	0	0	0	0	0	0	0	0	1	1	1	1	1	1	1	

Bit/Field	Name	Type	Reset	Description
31:7	reserved	RO	0	Software should not rely on the value of a reserved bit. To provide compatibility with future products, the value of a reserved bit should be preserved across a read-modify-write operation.
6	P6	R/W	1	<p>GPIO Port G Power Control</p> <p>The value of this bit does not have meaning unless the corresponding, active mode RCGCGPIO, SCGCGPIO or DCGCGPIO bit is cleared.</p> <p>Value Description</p> <p>1 GPIO Port G is powered, but does not receive a clock. In this case, the module is inactive.</p> <p>This configuration provides the second-lowest power consumption of the module because it consumes only leakage current.</p> <p>0 GPIO Port G is not powered and does not receive a clock. In this case, the module's state is not retained.</p> <p>This configuration provides the lowest power consumption state of the module because it consumes no dynamic nor leakage current.</p>

Bit/Field	Name	Type	Reset	Description
5	P5	R/W	1	<p>GPIO Port F Power Control</p> <p>The value of this bit does not have meaning unless the corresponding, active mode RCGCGPIO, SCGCGPIO or DCGCGPIO bit is cleared.</p> <p>Value Description</p> <p>1 GPIO Port F is powered, but does not receive a clock. In this case, the module is inactive.</p> <p>This configuration provides the second-lowest power consumption of the module because it consumes only leakage current.</p> <p>0 GPIO Port F is not powered and does not receive a clock. In this case, the module's state is not retained.</p> <p>This configuration provides the lowest power consumption state of the module because it consumes no dynamic nor leakage current.</p>
4	P4	R/W	1	<p>GPIO Port E Power Control</p> <p>The value of this bit does not have meaning unless the corresponding, active mode RCGCGPIO, SCGCGPIO or DCGCGPIO bit is cleared.</p> <p>Value Description</p> <p>1 GPIO Port E is powered, but does not receive a clock. In this case, the module is inactive.</p> <p>This configuration provides the second-lowest power consumption of the module because it consumes only leakage current.</p> <p>0 GPIO Port E is not powered and does not receive a clock. In this case, the module's state is not retained.</p> <p>This configuration provides the lowest power consumption state of the module because it consumes no dynamic nor leakage current.</p>
3	P3	R/W	1	<p>GPIO Port D Power Control</p> <p>The value of this bit does not have meaning unless the corresponding, active mode RCGCGPIO, SCGCGPIO or DCGCGPIO bit is cleared.</p> <p>Value Description</p> <p>1 GPIO Port D is powered, but does not receive a clock. In this case, the module is inactive.</p> <p>This configuration provides the second-lowest power consumption of the module because it consumes only leakage current.</p> <p>0 GPIO Port D is not powered and does not receive a clock. In this case, the module's state is not retained.</p> <p>This configuration provides the lowest power consumption state of the module because it consumes no dynamic nor leakage current.</p>

Bit/Field	Name	Type	Reset	Description
2	P2	R/W	1	<p>GPIO Port C Power Control</p> <p>The value of this bit does not have meaning unless the corresponding, active mode RCGCGPIO, SCGCGPIO or DCGCGPIO bit is cleared.</p> <p>Value Description</p> <p>1 GPIO Port C is powered, but does not receive a clock. In this case, the module is inactive.</p> <p>This configuration provides the second-lowest power consumption of the module because it consumes only leakage current.</p> <p>0 GPIO Port C is not powered and does not receive a clock. In this case, the module's state is not retained.</p> <p>This configuration provides the lowest power consumption state of the module because it consumes no dynamic nor leakage current.</p>
1	P1	R/W	1	<p>GPIO Port B Power Control</p> <p>The value of this bit does not have meaning unless the corresponding, active mode RCGCGPIO, SCGCGPIO or DCGCGPIO bit is cleared.</p> <p>Value Description</p> <p>1 GPIO Port B is powered, but does not receive a clock. In this case, the module is inactive.</p> <p>This configuration provides the second-lowest power consumption of the module because it consumes only leakage current.</p> <p>0 GPIO Port B is not powered and does not receive a clock. In this case, the module's state is not retained.</p> <p>This configuration provides the lowest power consumption state of the module because it consumes no dynamic nor leakage current.</p>
0	P0	R/W	1	<p>GPIO Port A Power Control</p> <p>The value of this bit does not have meaning unless the corresponding, active mode RCGCGPIO, SCGCGPIO or DCGCGPIO bit is cleared.</p> <p>Value Description</p> <p>1 GPIO Port A is powered, but does not receive a clock. In this case, the module is inactive.</p> <p>This configuration provides the second-lowest power consumption of the module because it consumes only leakage current.</p> <p>0 GPIO Port A is not powered and does not receive a clock. In this case, the module's state is not retained.</p> <p>This configuration provides the lowest power consumption state of the module because it consumes no dynamic nor leakage current.</p>

Register 97: Micro Direct Memory Access Power Control (PCDMA), offset 0x90C

The **PCDMA** register controls the power provided to the μ DMA module. Clearing the bit corresponding to the module indicates to the hardware that firmware requests that the peripheral be unpowered. When the bit in this register is set, the module's state is not retained. Software should perform a peripheral reset using the **SRDMA** register if the active mode changes and the corresponding bit in the **RCGCDMA**, **SCGCDMA**, or **DCGCDMA** register is a 1 or the P_n bit is changed from a 0 to a 1. Software must re-initialize the module when re-enabled due to the loss of state.

Note: The μ DMA module does not currently have the ability to respond to the power down request. Setting the bit in this register has no effect on power consumption. This register is provided for future software compatibility.

Micro Direct Memory Access Power Control (PCDMA)

Base 0x400F.E000
Offset 0x90C
Type R/W, reset 0x0000.0001

	31	30	29	28	27	26	25	24	23	22	21	20	19	18	17	16
	reserved															
Type	RO	RO	RO	RO	RO	RO	RO	RO	RO	RO	RO	RO	RO	RO	RO	RO
Reset	0	0	0	0	0	0	0	0	0	0	0	0	0	0	0	0
	15	14	13	12	11	10	9	8	7	6	5	4	3	2	1	0
	reserved															P0
Type	RO	RO	RO	RO	RO	RO	RO	RO	RO	RO	RO	RO	RO	RO	RO	R/W
Reset	0	0	0	0	0	0	0	0	0	0	0	0	0	0	0	1

Bit/Field	Name	Type	Reset	Description
31:1	reserved	RO	0	Software should not rely on the value of a reserved bit. To provide compatibility with future products, the value of a reserved bit should be preserved across a read-modify-write operation.
0	P0	R/W	1	<p>μDMA Module Power Control</p> <p>The value of this bit does not have meaning unless the corresponding, active mode RCGCDMA, SCGCDMA or DCGCDMA bit is cleared.</p>

Value Description

- | | |
|---|---|
| 1 | The μ DMA module is powered, but does not receive a clock. In this case, the module is inactive.

This configuration provides the second-lowest power consumption of the module because it consumes only leakage current. |
| 0 | The μ DMA module is not powered and does not receive a clock. In this case, the module's state is not retained.

This configuration provides the lowest power consumption state of the module because it consumes no dynamic nor leakage current. |

Register 98: Universal Asynchronous Receiver/Transmitter Power Control (PCUART), offset 0x918

The **PCUART** register controls the power provided to the UART modules. Clearing the bit corresponding to one of the modules indicates to the hardware that firmware requests that the peripheral be unpowered. When a bit in this register is set, the corresponding module's state is not retained. Software should perform a peripheral reset using the **SRUART** register if the active mode changes and the corresponding bit in the **RCGCUART**, **SCGCUART**, or **DCGCUART** register is a 1 or the P_n bit is changed from a 0 to a 1. Software must re-initialize the module when re-enabled due to the loss of state.

Note: The UART modules do not currently have the ability to respond to the power down request. Setting a bit in this register has no effect on power consumption. This register is provided for future software compatibility.

Universal Asynchronous Receiver/Transmitter Power Control (PCUART)

Base 0x400F.E000
 Offset 0x918
 Type R/W, reset 0x0000.00FF

	31	30	29	28	27	26	25	24	23	22	21	20	19	18	17	16
	reserved															
Type	RO	RO	RO	RO	RO	RO	RO	RO	RO	RO	RO	RO	RO	RO	RO	RO
Reset	0	0	0	0	0	0	0	0	0	0	0	0	0	0	0	0
	15	14	13	12	11	10	9	8	7	6	5	4	3	2	1	0
	reserved								P7	P6	P5	P4	P3	P2	P1	P0
Type	RO	RO	RO	RO	RO	RO	RO	RO	R/W	R/W	R/W	R/W	R/W	R/W	R/W	R/W
Reset	0	0	0	0	0	0	0	0	1	1	1	1	1	1	1	1

Bit/Field	Name	Type	Reset	Description
31:8	reserved	RO	0	Software should not rely on the value of a reserved bit. To provide compatibility with future products, the value of a reserved bit should be preserved across a read-modify-write operation.
7	P7	R/W	1	UART Module 7 Power Control The value of this bit does not have meaning unless the corresponding, active mode RCGCUART , SCGCUART or DCGCUART bit is cleared.

Value	Description
1	UART module 7 is powered, but does not receive a clock. In this case, the module is inactive. This configuration provides the second-lowest power consumption of the module because it consumes only leakage current.
0	UART module 7 is not powered and does not receive a clock. In this case, the module's state is not retained. This configuration provides the lowest power consumption state of the module because it consumes no dynamic nor leakage current.

Bit/Field	Name	Type	Reset	Description
6	P6	R/W	1	<p>UART Module 6 Power Control</p> <p>The value of this bit does not have meaning unless the corresponding, active mode RCGCUART, SCGCUART or DCGCUART bit is cleared.</p> <p>Value Description</p> <p>1 UART module 6 is powered, but does not receive a clock. In this case, the module is inactive.</p> <p> This configuration provides the second-lowest power consumption of the module because it consumes only leakage current.</p> <p>0 UART module 6 is not powered and does not receive a clock. In this case, the module's state is not retained.</p> <p> This configuration provides the lowest power consumption state of the module because it consumes no dynamic nor leakage current.</p>
5	P5	R/W	1	<p>UART Module 5 Power Control</p> <p>The value of this bit does not have meaning unless the corresponding, active mode RCGCUART, SCGCUART or DCGCUART bit is cleared.</p> <p>Value Description</p> <p>1 UART module 5 is powered, but does not receive a clock. In this case, the module is inactive.</p> <p> This configuration provides the second-lowest power consumption of the module because it consumes only leakage current.</p> <p>0 UART module 5 is not powered and does not receive a clock. In this case, the module's state is not retained.</p> <p> This configuration provides the lowest power consumption state of the module because it consumes no dynamic nor leakage current.</p>
4	P4	R/W	1	<p>UART Module 4 Power Control</p> <p>The value of this bit does not have meaning unless the corresponding, active mode RCGCUART, SCGCUART or DCGCUART bit is cleared.</p> <p>Value Description</p> <p>1 UART module 4 is powered, but does not receive a clock. In this case, the module is inactive.</p> <p> This configuration provides the second-lowest power consumption of the module because it consumes only leakage current.</p> <p>0 UART module 4 is not powered and does not receive a clock. In this case, the module's state is not retained.</p> <p> This configuration provides the lowest power consumption state of the module because it consumes no dynamic nor leakage current.</p>

Bit/Field	Name	Type	Reset	Description
3	P3	R/W	1	<p>UART Module 3 Power Control</p> <p>The value of this bit does not have meaning unless the corresponding, active mode RCGCUART, SCGCUART or DCGCUART bit is cleared.</p> <p>Value Description</p> <p>1 UART module 3 is powered, but does not receive a clock. In this case, the module is inactive.</p> <p> This configuration provides the second-lowest power consumption of the module because it consumes only leakage current.</p> <p>0 UART module 3 is not powered and does not receive a clock. In this case, the module's state is not retained.</p> <p> This configuration provides the lowest power consumption state of the module because it consumes no dynamic nor leakage current.</p>
2	P2	R/W	1	<p>UART Module 2 Power Control</p> <p>The value of this bit does not have meaning unless the corresponding, active mode RCGCUART, SCGCUART or DCGCUART bit is cleared.</p> <p>Value Description</p> <p>1 UART module 2 is powered, but does not receive a clock. In this case, the module is inactive.</p> <p> This configuration provides the second-lowest power consumption of the module because it consumes only leakage current.</p> <p>0 UART module 2 is not powered and does not receive a clock. In this case, the module's state is not retained.</p> <p> This configuration provides the lowest power consumption state of the module because it consumes no dynamic nor leakage current.</p>
1	P1	R/W	1	<p>UART Module 1 Power Control</p> <p>The value of this bit does not have meaning unless the corresponding, active mode RCGCUART, SCGCUART or DCGCUART bit is cleared.</p> <p>Value Description</p> <p>1 UART module 1 is powered, but does not receive a clock. In this case, the module is inactive.</p> <p> This configuration provides the second-lowest power consumption of the module because it consumes only leakage current.</p> <p>0 UART module 1 is not powered and does not receive a clock. In this case, the module's state is not retained.</p> <p> This configuration provides the lowest power consumption state of the module because it consumes no dynamic nor leakage current.</p>

Bit/Field	Name	Type	Reset	Description
0	P0	R/W	1	<p>UART Module 70 Power Control</p> <p>The value of this bit does not have meaning unless the corresponding, active mode RCGCUART, SCGCUART or DCGCUART bit is cleared.</p> <p>Value Description</p> <p>1 UART module 0 is powered, but does not receive a clock. In this case, the module is inactive.</p> <p> This configuration provides the second-lowest power consumption of the module because it consumes only leakage current.</p> <p>0 UART module 0 is not powered and does not receive a clock. In this case, the module's state is not retained.</p> <p> This configuration provides the lowest power consumption state of the module because it consumes no dynamic nor leakage current.</p>

Register 99: Synchronous Serial Interface Power Control (PCSSI), offset 0x91C

The **PCSSI** register controls the power provided to the SSI modules. Clearing the bit corresponding to one of the modules indicates to the hardware that firmware requests that the peripheral be unpowered. When a bit in this register is set, the corresponding module's state is not retained. Software should perform a peripheral reset using the **SRSSI** register if the active mode changes and the corresponding bit in the **RCGCSI**, **SCGCSI**, or **DCGCSI** register is a 1 or the P_n bit is changed from a 0 to a 1. Software must re-initialize the module when re-enabled due to the loss of state.

Note: The SSI modules do not currently have the ability to respond to the power down request. Setting a bit in this register has no effect on power consumption. This register is provided for future software compatibility.

Synchronous Serial Interface Power Control (PCSSI)

Base 0x400F.E000
 Offset 0x91C
 Type R/W, reset 0x0000.000F

	31	30	29	28	27	26	25	24	23	22	21	20	19	18	17	16	
	reserved																
Type	RO	RO	RO	RO	RO	RO	RO	RO	RO	RO	RO	RO	RO	RO	RO	RO	
Reset	0	0	0	0	0	0	0	0	0	0	0	0	0	0	0	0	
	15	14	13	12	11	10	9	8	7	6	5	4	3	2	1	0	
	reserved													P3	P2	P1	P0
Type	RO	RO	RO	RO	RO	RO	RO	RO	RO	RO	RO	RO	RO	R/W	R/W	R/W	R/W
Reset	0	0	0	0	0	0	0	0	0	0	0	0	0	1	1	1	1

Bit/Field	Name	Type	Reset	Description
31:4	reserved	RO	0	Software should not rely on the value of a reserved bit. To provide compatibility with future products, the value of a reserved bit should be preserved across a read-modify-write operation.
3	P3	R/W	1	<p>SSI Module 3 Power Control</p> <p>The value of this bit does not have meaning unless the corresponding, active mode RCGCSI, SCGCSI or DCGCSI bit is cleared.</p> <p>Value Description</p> <p>1 SSI module 3 is powered, but does not receive a clock. In this case, the module is inactive. This configuration provides the second-lowest power consumption of the module because it consumes only leakage current.</p> <p>0 SSI module 3 is not powered and does not receive a clock. In this case, the module's state is not retained. This configuration provides the lowest power consumption state of the module because it consumes no dynamic nor leakage current.</p>

Bit/Field	Name	Type	Reset	Description
2	P2	R/W	1	<p>SSI Module 2 Power Control</p> <p>The value of this bit does not have meaning unless the corresponding, active mode RCGCSSI, SCGCSSI or DCGCSSI bit is cleared.</p> <p>Value Description</p> <p>1 SSI module 2 is powered, but does not receive a clock. In this case, the module is inactive.</p> <p>This configuration provides the second-lowest power consumption of the module because it consumes only leakage current.</p> <p>0 SSI module 2 is not powered and does not receive a clock. In this case, the module's state is not retained.</p> <p>This configuration provides the lowest power consumption state of the module because it consumes no dynamic nor leakage current.</p>
1	P1	R/W	1	<p>SSI Module 1 Power Control</p> <p>The value of this bit does not have meaning unless the corresponding, active mode RCGCSSI, SCGCSSI or DCGCSSI bit is cleared.</p> <p>Value Description</p> <p>1 SSI module 1 is powered, but does not receive a clock. In this case, the module is inactive.</p> <p>This configuration provides the second-lowest power consumption of the module because it consumes only leakage current.</p> <p>0 SSI module 1 is not powered and does not receive a clock. In this case, the module's state is not retained.</p> <p>This configuration provides the lowest power consumption state of the module because it consumes no dynamic nor leakage current.</p>
0	P0	R/W	1	<p>SSI Module 0 Power Control</p> <p>The value of this bit does not have meaning unless the corresponding, active mode RCGCSSI, SCGCSSI or DCGCSSI bit is cleared.</p> <p>Value Description</p> <p>1 SSI module 0 is powered, but does not receive a clock. In this case, the module is inactive.</p> <p>This configuration provides the second-lowest power consumption of the module because it consumes only leakage current.</p> <p>0 SSI module 0 is not powered and does not receive a clock. In this case, the module's state is not retained.</p> <p>This configuration provides the lowest power consumption state of the module because it consumes no dynamic nor leakage current.</p>

Register 100: Inter-Integrated Circuit Power Control (PCI2C), offset 0x920

The **PCI2C** register controls the power provided to the I²C modules. Clearing the bit corresponding to one of the modules indicates to the hardware that firmware requests that the peripheral be unpowered. When a bit in this register is set, the corresponding module's state is not retained. Software should perform a peripheral reset using the **SRI2C** register if the active mode changes and the corresponding bit in the **RCGCI2C**, **SCGCI2C**, or **DCGCI2C** register is a 1 or the P_n bit is changed from a 0 to a 1. Software must re-initialize the module when re-enabled due to the loss of state.

Note: The I²C modules do not currently have the ability to respond to the power down request. Setting a bit in this register has no effect on power consumption. This register is provided for future software compatibility.

Inter-Integrated Circuit Power Control (PCI2C)

Base 0x400F.E000
 Offset 0x920
 Type R/W, reset 0x0000.003F

	31	30	29	28	27	26	25	24	23	22	21	20	19	18	17	16	
	reserved																
Type	RO	RO	RO	RO	RO	RO	RO	RO	RO	RO	RO	RO	RO	RO	RO	RO	
Reset	0	0	0	0	0	0	0	0	0	0	0	0	0	0	0	0	
	15	14	13	12	11	10	9	8	7	6	5	4	3	2	1	0	
	reserved											P5	P4	P3	P2	P1	P0
Type	RO	RO	RO	RO	RO	RO	RO	RO	RO	RO	R/W	R/W	R/W	R/W	R/W	R/W	
Reset	0	0	0	0	0	0	0	0	0	0	1	1	1	1	1	1	

Bit/Field	Name	Type	Reset	Description
31:6	reserved	RO	0	Software should not rely on the value of a reserved bit. To provide compatibility with future products, the value of a reserved bit should be preserved across a read-modify-write operation.
5	P5	R/W	1	<p>I²C Module 5 Power Control</p> <p>The value of this bit does not have meaning unless the corresponding, active mode RCGCI2C, SCGCI2C or DCGCI2C bit is cleared.</p> <p>Value Description</p> <p>1 I²C module 5 is powered, but does not receive a clock. In this case, the module is inactive. This configuration provides the second-lowest power consumption of the module because it consumes only leakage current.</p> <p>0 I²C module 5 is not powered and does not receive a clock. In this case, the module's state is not retained. This configuration provides the lowest power consumption state of the module because it consumes no dynamic nor leakage current.</p>

Bit/Field	Name	Type	Reset	Description
4	P4	R/W	1	<p>I²C Module 4 Power Control</p> <p>The value of this bit does not have meaning unless the corresponding, active mode RCGCI2C, SCGCI2C or DCGCI2C bit is cleared.</p> <p>Value Description</p> <p>1 I²C module 4 is powered, but does not receive a clock. In this case, the module is inactive. This configuration provides the second-lowest power consumption of the module because it consumes only leakage current.</p> <p>0 I²C module 4 is not powered and does not receive a clock. In this case, the module's state is not retained. This configuration provides the lowest power consumption state of the module because it consumes no dynamic nor leakage current.</p>
3	P3	R/W	1	<p>I²C Module 3 Power Control</p> <p>The value of this bit does not have meaning unless the corresponding, active mode RCGCI2C, SCGCI2C or DCGCI2C bit is cleared.</p> <p>Value Description</p> <p>1 I²C module 3 is powered, but does not receive a clock. In this case, the module is inactive. This configuration provides the second-lowest power consumption of the module because it consumes only leakage current.</p> <p>0 I²C module 3 is not powered and does not receive a clock. In this case, the module's state is not retained. This configuration provides the lowest power consumption state of the module because it consumes no dynamic nor leakage current.</p>
2	P2	R/W	1	<p>I²C Module 2 Power Control</p> <p>The value of this bit does not have meaning unless the corresponding, active mode RCGCI2C, SCGCI2C or DCGCI2C bit is cleared.</p> <p>Value Description</p> <p>1 I²C module 2 is powered, but does not receive a clock. In this case, the module is inactive. This configuration provides the second-lowest power consumption of the module because it consumes only leakage current.</p> <p>0 I²C module 2 is not powered and does not receive a clock. In this case, the module's state is not retained. This configuration provides the lowest power consumption state of the module because it consumes no dynamic nor leakage current.</p>

Bit/Field	Name	Type	Reset	Description
1	P1	R/W	1	<p>I²C Module 1 Power Control</p> <p>The value of this bit does not have meaning unless the corresponding, active mode RCGCI2C, SCGCI2C or DCGCI2C bit is cleared.</p> <p>Value Description</p> <p>1 I²C module 1 is powered, but does not receive a clock. In this case, the module is inactive. This configuration provides the second-lowest power consumption of the module because it consumes only leakage current.</p> <p>0 I²C module 1 is not powered and does not receive a clock. In this case, the module's state is not retained. This configuration provides the lowest power consumption state of the module because it consumes no dynamic nor leakage current.</p>
0	P0	R/W	1	<p>I²C Module 0 Power Control</p> <p>The value of this bit does not have meaning unless the corresponding, active mode RCGCI2C, SCGCI2C or DCGCI2C bit is cleared.</p> <p>Value Description</p> <p>1 I²C module 0 is powered, but does not receive a clock. In this case, the module is inactive. This configuration provides the second-lowest power consumption of the module because it consumes only leakage current.</p> <p>0 I²C module 0 is not powered and does not receive a clock. In this case, the module's state is not retained. This configuration provides the lowest power consumption state of the module because it consumes no dynamic nor leakage current.</p>

Register 101: Universal Serial Bus Power Control (PCUSB), offset 0x928

The **PCUSB** register controls the power provided to the USB module. Clearing the bit corresponding to the module indicates to the hardware that firmware requests that the peripheral be unpowered. When the bit in this register is set, the module's state is not retained. Software should perform a peripheral reset using the **SRUSB** register if the active mode changes and the corresponding bit in the **RCGCUSB**, **SCGCUSB**, or **DCGCUSB** register is a 1 or the P_n bit is changed from a 0 to a 1. Software must re-initialize the module when re-enabled due to the loss of state.

Universal Serial Bus Power Control (PCUSB)

Base 0x400F.E000

Offset 0x928

Type R/W, reset 0x0000.0001

	31	30	29	28	27	26	25	24	23	22	21	20	19	18	17	16
	reserved															
Type	RO	RO	RO	RO	RO	RO	RO	RO	RO	RO	RO	RO	RO	RO	RO	RO
Reset	0	0	0	0	0	0	0	0	0	0	0	0	0	0	0	0
	15	14	13	12	11	10	9	8	7	6	5	4	3	2	1	0
	reserved															P0
Type	RO	RO	RO	RO	RO	RO	RO	RO	RO	RO	RO	RO	RO	RO	RO	R/W
Reset	0	0	0	0	0	0	0	0	0	0	0	0	0	0	0	1

Bit/Field	Name	Type	Reset	Description
31:1	reserved	RO	0	Software should not rely on the value of a reserved bit. To provide compatibility with future products, the value of a reserved bit should be preserved across a read-modify-write operation.
0	P0	R/W	1	USB Module Power Control The value of this bit does not have meaning unless the corresponding, active mode RCGCUSB , SCGCUSB or DCGCUSB bit is cleared.

Value Description

- | | |
|---|---|
| 1 | The USB module is powered, but does not receive a clock. In this case, the module is inactive.

This configuration provides the second-lowest power consumption of the module because it consumes only leakage current. |
| 0 | The USB module is not powered and does not receive a clock. In this case, the module's state is not retained.

This configuration provides the lowest power consumption state of the module because it consumes no dynamic nor leakage current. |

Register 102: Controller Area Network Power Control (PCCAN), offset 0x934

The **PCCAN** register controls the power provided to the CAN modules. Clearing the bit corresponding to one of the modules indicates to the hardware that firmware requests that the peripheral be unpowered. When a bit in this register is set, the corresponding module's state is not retained. Software should perform a peripheral reset using the **SRCAN** register if the active mode changes and the corresponding bit in the **RCGCCAN**, **SCGCCAN**, or **DCGCCAN** register is a 1 or the P_n bit is changed from a 0 to a 1. Software must re-initialize the module when re-enabled due to the loss of state.

Controller Area Network Power Control (PCCAN)

Base 0x400F.E000
 Offset 0x934
 Type R/W, reset 0x0000.0003

	31	30	29	28	27	26	25	24	23	22	21	20	19	18	17	16	
	reserved																
Type	RO	RO	RO	RO	RO	RO	RO	RO	RO	RO	RO	RO	RO	RO	RO	RO	
Reset	0	0	0	0	0	0	0	0	0	0	0	0	0	0	0	0	
	15	14	13	12	11	10	9	8	7	6	5	4	3	2	1	0	
	reserved															P1	P0
Type	RO	RO	RO	RO	RO	RO	RO	RO	RO	RO	RO	RO	RO	RO	RO	R/W	R/W
Reset	0	0	0	0	0	0	0	0	0	0	0	0	0	0	0	1	1

Bit/Field	Name	Type	Reset	Description
31:2	reserved	RO	0	Software should not rely on the value of a reserved bit. To provide compatibility with future products, the value of a reserved bit should be preserved across a read-modify-write operation.
1	P1	R/W	1	<p>CAN Module 1 Power Control</p> <p>The value of this bit does not have meaning unless the corresponding, active mode RCGCCAN, SCGCCAN or DCGCCAN bit is cleared.</p> <p>Value Description</p> <p>1 CAN module 1 is powered, but does not receive a clock. In this case, the module is inactive.</p> <p>This configuration provides the second-lowest power consumption of the module because it consumes only leakage current.</p> <p>0 CAN module 1 is not powered and does not receive a clock. In this case, the module's state is not retained.</p> <p>This configuration provides the lowest power consumption state of the module because it consumes no dynamic nor leakage current.</p>

Bit/Field	Name	Type	Reset	Description
0	P0	R/W	1	<p>CAN Module 0 Power Control</p> <p>The value of this bit does not have meaning unless the corresponding, active mode RCGCCAN, SCGCCAN or DCGCCAN bit is cleared.</p> <p>Value Description</p> <p>1 CAN module 0 is powered, but does not receive a clock. In this case, the module is inactive.</p> <p>This configuration provides the second-lowest power consumption of the module because it consumes only leakage current.</p> <p>0 CAN module 0 is not powered and does not receive a clock. In this case, the module's state is not retained.</p> <p>This configuration provides the lowest power consumption state of the module because it consumes no dynamic nor leakage current.</p>

Register 103: Analog-to-Digital Converter Power Control (PCADC), offset 0x938

The **PCADC** register controls the power provided to the ADC modules. Clearing the bit corresponding to one of the modules indicates to the hardware that firmware requests that the peripheral be unpowered. When a bit in this register is set, the corresponding module's state is not retained. Software should perform a peripheral reset using the **SRADC** register if the active mode changes and the corresponding bit in the **RCGCADC**, **SCGCADC**, or **DCGCADC** register is a 1 or the P_n bit is changed from a 0 to a 1. Software must re-initialize the module when re-enabled due to the loss of state.

Note: The ADC modules do not currently have the ability to respond to the power down request. Setting a bit in this register has no effect on power consumption. This register is provided for future software compatibility.

Analog-to-Digital Converter Power Control (PCADC)

Base 0x400F.E000
 Offset 0x938
 Type R/W, reset 0x0000.0003

	31	30	29	28	27	26	25	24	23	22	21	20	19	18	17	16	
	reserved																
Type	RO	RO	RO	RO	RO	RO	RO	RO	RO	RO	RO	RO	RO	RO	RO	RO	
Reset	0	0	0	0	0	0	0	0	0	0	0	0	0	0	0	0	
	15	14	13	12	11	10	9	8	7	6	5	4	3	2	1	0	
	reserved															P1	P0
Type	RO	RO	RO	RO	RO	RO	RO	RO	RO	RO	RO	RO	RO	RO	R/W	R/W	
Reset	0	0	0	0	0	0	0	0	0	0	0	0	0	0	1	1	

Bit/Field	Name	Type	Reset	Description
31:2	reserved	RO	0	Software should not rely on the value of a reserved bit. To provide compatibility with future products, the value of a reserved bit should be preserved across a read-modify-write operation.
1	P1	R/W	1	ADC Module 1 Power Control The value of this bit does not have meaning unless the corresponding, active mode RCGCADC , SCGCADC or DCGCADC bit is cleared.

Value	Description
1	ADC module 1 is powered, but does not receive a clock. In this case, the module is inactive. This configuration provides the second-lowest power consumption of the module because it consumes only leakage current.
0	ADC module 1 is not powered and does not receive a clock. In this case, the module's state is not retained. This configuration provides the lowest power consumption state of the module because it consumes no dynamic nor leakage current.

Bit/Field	Name	Type	Reset	Description
0	P0	R/W	1	<p>ADC Module 0 Power Control</p> <p>The value of this bit does not have meaning unless the corresponding, active mode RCGCADC, SCGCADC or DCGCADC bit is cleared.</p> <p>Value Description</p> <p>1 ADC module 0 is powered, but does not receive a clock. In this case, the module is inactive.</p> <p> This configuration provides the second-lowest power consumption of the module because it consumes only leakage current.</p> <p>0 ADC module 0 is not powered and does not receive a clock. In this case, the module's state is not retained.</p> <p> This configuration provides the lowest power consumption state of the module because it consumes no dynamic nor leakage current.</p>

Register 104: Analog Comparator Power Control (PCACMP), offset 0x93C

The **PCACMP** register controls the power provided to the analog comparator module. Clearing the bit corresponding to one of the modules indicates to the hardware that firmware requests that the peripheral be unpowered. When a bit in this register is set, the corresponding module's state is not retained. Software should perform a peripheral reset using the **SRACMP** register if the active mode changes and the corresponding bit in the **RCGCACMP**, **SCGCACMP**, or **DCGCACMP** register is a 1 or the P_n bit is changed from a 0 to a 1. Software must re-initialize the module when re-enabled due to the loss of state.

Note: The analog comparator module does not currently have the ability to respond to the power down request. Setting a bit in this register has no effect on power consumption. This register is provided for future software compatibility.

Analog Comparator Power Control (PCACMP)

Base 0x400F.E000
Offset 0x93C
Type R/W, reset 0x0000.0001

	31	30	29	28	27	26	25	24	23	22	21	20	19	18	17	16
	reserved															
Type	RO	RO	RO	RO	RO	RO	RO	RO	RO	RO	RO	RO	RO	RO	RO	RO
Reset	0	0	0	0	0	0	0	0	0	0	0	0	0	0	0	0
	15	14	13	12	11	10	9	8	7	6	5	4	3	2	1	0
	reserved															P0
Type	RO	RO	RO	RO	RO	RO	RO	RO	RO	RO	RO	RO	RO	RO	RO	R/W
Reset	0	0	0	0	0	0	0	0	0	0	0	0	0	0	0	1

Bit/Field	Name	Type	Reset	Description
31:1	reserved	RO	0	Software should not rely on the value of a reserved bit. To provide compatibility with future products, the value of a reserved bit should be preserved across a read-modify-write operation.
0	P0	R/W	1	<p>Analog Comparator Module 0 Power Control</p> <p>The value of this bit does not have meaning unless the corresponding, active mode RCGCACMP, SCGCACMP or DCGCACMP bit is cleared.</p> <p>Value Description</p> <p>1 The analog comparator module is powered, but does not receive a clock. In this case, the module is inactive. This configuration provides the second-lowest power consumption of the module because it consumes only leakage current.</p> <p>0 The analog comparator module is not powered and does not receive a clock. In this case, the module's state is not retained. This configuration provides the lowest power consumption state of the module because it consumes no dynamic nor leakage current.</p>

Register 105: Pulse Width Modulator Power Control (PCPWM), offset 0x940

The **PCPWM** register controls the power provided to the PWM modules. Clearing the bit corresponding to one of the modules indicates to the hardware that firmware requests that the peripheral be unpowered. When a bit in this register is set, the corresponding module's state is not retained. Software should perform a peripheral reset using the **SRPWM** register if the active mode changes and the corresponding bit in the **RCGCPWM**, **SCGCPWM**, or **DCGCPWM** register is a 1 or the P_n bit is changed from a 0 to a 1. Software must re-initialize the module when re-enabled due to the loss of state.

Note: The PWM modules do not currently have the ability to respond to the power down request. Setting a bit in this register has no effect on power consumption. This register is provided for future software compatibility.

Pulse Width Modulator Power Control (PCPWM)

Base 0x400F.E000

Offset 0x940

Type R/W, reset 0x0000.0003

	31	30	29	28	27	26	25	24	23	22	21	20	19	18	17	16	
	reserved																
Type	RO	RO	RO	RO	RO	RO	RO	RO	RO	RO	RO	RO	RO	RO	RO	RO	
Reset	0	0	0	0	0	0	0	0	0	0	0	0	0	0	0	0	
	15	14	13	12	11	10	9	8	7	6	5	4	3	2	1	0	
	reserved															P1	P0
Type	RO	RO	RO	RO	RO	RO	RO	RO	RO	RO	RO	RO	RO	RO	RO	R/W	R/W
Reset	0	0	0	0	0	0	0	0	0	0	0	0	0	0	0	1	1

Bit/Field	Name	Type	Reset	Description
31:2	reserved	RO	0	Software should not rely on the value of a reserved bit. To provide compatibility with future products, the value of a reserved bit should be preserved across a read-modify-write operation.
1	P1	R/W	1	<p>PWM Module 1 Power Control</p> <p>The value of this bit does not have meaning unless the corresponding, active mode RCGCPWM, SCGCPWM or DCGCPWM bit is cleared.</p> <p>Value Description</p> <p>1 PWM module 1 is powered, but does not receive a clock. In this case, the module is inactive. This configuration provides the second-lowest power consumption of the module because it consumes only leakage current.</p> <p>0 PWM module 1 is not powered and does not receive a clock. In this case, the module's state is not retained. This configuration provides the lowest power consumption state of the module because it consumes no dynamic nor leakage current.</p>

Bit/Field	Name	Type	Reset	Description
0	P0	R/W	1	<p>PWM Module 0 Power Control</p> <p>The value of this bit does not have meaning unless the corresponding, active mode RCGCPWM, SCGCPWM or DCGCPWM bit is cleared.</p> <p>Value Description</p> <p>1 PWM module 0 is powered, but does not receive a clock. In this case, the module is inactive.</p> <p>This configuration provides the second-lowest power consumption of the module because it consumes only leakage current.</p> <p>0 PWM module 0 is not powered and does not receive a clock. In this case, the module's state is not retained.</p> <p>This configuration provides the lowest power consumption state of the module because it consumes no dynamic nor leakage current.</p>

Register 106: Quadrature Encoder Interface Power Control (PCQEI), offset 0x944

The **PCQEI** register controls the power provided to the QEI modules. Clearing the bit corresponding to one of the modules indicates to the hardware that firmware requests that the peripheral be unpowered. When a bit in this register is set, the corresponding module's state is not retained. Software should perform a peripheral reset using the **SRQEI** register if the active mode changes and the corresponding bit in the **RCGCQEI**, **SCGCQEI**, or **DCGCQEI** register is a 1 or the **Pn** bit is changed from a 0 to a 1. Software must re-initialize the module when re-enabled due to the loss of state.

Note: The QEI modules do not currently have the ability to respond to the power down request. Setting a bit in this register has no effect on power consumption. This register is provided for future software compatibility.

Quadrature Encoder Interface Power Control (PCQEI)

Base 0x400F.E000

Offset 0x944

Type R/W, reset 0x0000.0003

	31	30	29	28	27	26	25	24	23	22	21	20	19	18	17	16	
	reserved																
Type	RO	RO	RO	RO	RO	RO	RO	RO	RO	RO	RO	RO	RO	RO	RO	RO	
Reset	0	0	0	0	0	0	0	0	0	0	0	0	0	0	0	0	
	15	14	13	12	11	10	9	8	7	6	5	4	3	2	1	0	
	reserved															P1	P0
Type	RO	RO	RO	RO	RO	RO	RO	RO	RO	RO	RO	RO	RO	RO	R/W	R/W	
Reset	0	0	0	0	0	0	0	0	0	0	0	0	0	0	1	1	

Bit/Field	Name	Type	Reset	Description
31:2	reserved	RO	0	Software should not rely on the value of a reserved bit. To provide compatibility with future products, the value of a reserved bit should be preserved across a read-modify-write operation.
1	P1	R/W	1	QEI Module 1 Power Control The value of this bit does not have meaning unless the corresponding, active mode RCGCQEI , SCGCQEI or DCGCQEI bit is cleared.

Value Description

Value	Description
1	QEI module 1 is powered, but does not receive a clock. In this case, the module is inactive. This configuration provides the second-lowest power consumption of the module because it consumes only leakage current.
0	QEI module 1 is not powered and does not receive a clock. In this case, the module's state is not retained. This configuration provides the lowest power consumption state of the module because it consumes no dynamic nor leakage current.

Bit/Field	Name	Type	Reset	Description
0	P0	R/W	1	<p>QEI Module 0 Power Control</p> <p>The value of this bit does not have meaning unless the corresponding, active mode RCGCQEI, SCGCQEI or DCGCQEI bit is cleared.</p> <p>Value Description</p> <p>1 QEI module 0 is powered, but does not receive a clock. In this case, the module is inactive.</p> <p>This configuration provides the second-lowest power consumption of the module because it consumes only leakage current.</p> <p>0 QEI module 0 is not powered and does not receive a clock. In this case, the module's state is not retained.</p> <p>This configuration provides the lowest power consumption state of the module because it consumes no dynamic nor leakage current.</p>

Register 107: EEPROM Power Control (PCEEPROM), offset 0x958

The **PCEEPROM** register controls the power provided to the EEPROM module. Clearing the bit corresponding to the module indicates to the hardware that firmware requests that the peripheral be unpowered. When the bit in this register is set, the module's state is not retained. Software should perform a peripheral reset using the **SREEPROM** register if the active mode changes and the corresponding bit in the **RCGCEEPROM**, **SCGCEEPROM**, or **DCGCEEPROM** register is a 1 or the **Pn** bit is changed from a 0 to a 1. Software must re-initialize the module when re-enabled due to the loss of state.

Note: The EEPROM module does not currently have the ability to respond to the power down request. Setting a bit in this register has no effect on power consumption. This register is provided for future software compatibility.

EEPROM Power Control (PCEEPROM)

Base 0x400F.E000

Offset 0x958

Type R/W, reset 0x0000.0001

	31	30	29	28	27	26	25	24	23	22	21	20	19	18	17	16
	reserved															
Type	RO	RO	RO	RO	RO	RO	RO	RO	RO	RO	RO	RO	RO	RO	RO	RO
Reset	0	0	0	0	0	0	0	0	0	0	0	0	0	0	0	0
	15	14	13	12	11	10	9	8	7	6	5	4	3	2	1	0
	reserved															P0
Type	RO	RO	RO	RO	RO	RO	RO	RO	RO	RO	RO	RO	RO	RO	RO	R/W
Reset	0	0	0	0	0	0	0	0	0	0	0	0	0	0	0	1

Bit/Field	Name	Type	Reset	Description
31:1	reserved	RO	0	Software should not rely on the value of a reserved bit. To provide compatibility with future products, the value of a reserved bit should be preserved across a read-modify-write operation.
0	P0	R/W	1	EEPROM Module Power Control The value of this bit does not have meaning unless the corresponding, active mode RCGCEEPROM , SCGCEEPROM or DCGCEEPROM bit is cleared.

Value Description

Value	Description
1	The EEPROM module is powered, but does not receive a clock. In this case, the module is inactive. This configuration provides the second-lowest power consumption of the module because it consumes only leakage current.
0	The EEPROM module is not powered and does not receive a clock. In this case, the module's state is not retained. This configuration provides the lowest power consumption state of the module because it consumes no dynamic nor leakage current.

Register 108: 32/64-Bit Wide General-Purpose Timer Power Control (PCWTIMER), offset 0x95C

The **PCWTIMER** register controls the power provided to the 32/64-bit wide timer modules. Clearing the bit corresponding to one of the modules indicates to the hardware that firmware requests that the peripheral be unpowered. When a bit in this register is set, the corresponding modules state is not retained. Software should perform a peripheral reset using the **SRWTIMER** register if the active mode changes and the corresponding bit in the **RCGCWTIMER**, **SCGCWTIMER**, or **DCGCWTIMER** register is a 1 or the **Pn** bit is changed from a 0 to a 1. Software must re-initialize the module when re-enabled due to the loss of state.

Note: The timer modules do not currently have the ability to respond to the power down request. Setting a bit in this register has no effect on power consumption. This register is provided for future software compatibility.

32/64-Bit Wide General-Purpose Timer Power Control (PCWTIMER)

Base 0x400F.E000
 Offset 0x95C
 Type R/W, reset 0x0000.0000

	31	30	29	28	27	26	25	24	23	22	21	20	19	18	17	16	
	reserved																
Type	RO	RO	RO	RO	RO	RO	RO	RO	RO	RO	RO	RO	RO	RO	RO	RO	
Reset	0	0	0	0	0	0	0	0	0	0	0	0	0	0	0	0	
	15	14	13	12	11	10	9	8	7	6	5	4	3	2	1	0	
	reserved											P5	P4	P3	P2	P1	P0
Type	RO	RO	RO	RO	RO	RO	RO	RO	RO	RO	R/W	R/W	R/W	R/W	R/W	R/W	
Reset	0	0	0	0	0	0	0	0	0	0	1	1	1	1	1	1	

Bit/Field	Name	Type	Reset	Description
31:6	reserved	RO	0	Software should not rely on the value of a reserved bit. To provide compatibility with future products, the value of a reserved bit should be preserved across a read-modify-write operation.
5	P5	R/W	1	<p>32/64-Bit Wide General-Purpose Timer 5 Power Control</p> <p>The value of this bit does not have meaning unless the corresponding, active mode RCGCWTIMER, SCGCWTIMER or DCGCWTIMER bit is cleared.</p> <p>Value Description</p> <p>1 Timer module 5 is powered, but does not receive a clock. In this case, the module is inactive. This configuration provides the second-lowest power consumption of the module because it consumes only leakage current.</p> <p>0 Timer module 5 is not powered and does not receive a clock. In this case, the module's state is not retained. This configuration provides the lowest power consumption state of the module because it consumes no dynamic nor leakage current.</p>

Bit/Field	Name	Type	Reset	Description
4	P4	R/W	1	<p>32/64-Bit Wide General-Purpose Timer 4 Power Control</p> <p>The value of this bit does not have meaning unless the corresponding, active mode RCGCWTIMER, SCGCWTIMER or DCGCWTIMER bit is cleared.</p> <p>Value Description</p> <p>1 Timer module 4 is powered, but does not receive a clock. In this case, the module is inactive. This configuration provides the second-lowest power consumption of the module because it consumes only leakage current.</p> <p>0 Timer module 4 is not powered and does not receive a clock. In this case, the module's state is not retained. This configuration provides the lowest power consumption state of the module because it consumes no dynamic nor leakage current.</p>
3	P3	R/W	1	<p>32/64-Bit Wide General-Purpose Timer 3 Power Control</p> <p>The value of this bit does not have meaning unless the corresponding, active mode RCGCWTIMER, SCGCWTIMER or DCGCWTIMER bit is cleared.</p> <p>Value Description</p> <p>1 Timer module 3 is powered, but does not receive a clock. In this case, the module is inactive. This configuration provides the second-lowest power consumption of the module because it consumes only leakage current.</p> <p>0 Timer module 3 is not powered and does not receive a clock. In this case, the module's state is not retained. This configuration provides the lowest power consumption state of the module because it consumes no dynamic nor leakage current.</p>
2	P2	R/W	1	<p>32/64-Bit Wide General-Purpose Timer 2 Power Control</p> <p>The value of this bit does not have meaning unless the corresponding, active mode RCGCWTIMER, SCGCWTIMER or DCGCWTIMER bit is cleared.</p> <p>Value Description</p> <p>1 Timer module 2 is powered, but does not receive a clock. In this case, the module is inactive. This configuration provides the second-lowest power consumption of the module because it consumes only leakage current.</p> <p>0 Timer module 2 is not powered and does not receive a clock. In this case, the module's state is not retained. This configuration provides the lowest power consumption state of the module because it consumes no dynamic nor leakage current.</p>

Bit/Field	Name	Type	Reset	Description
1	P1	R/W	1	<p>32/64-Bit Wide General-Purpose Timer 1 Power Control</p> <p>The value of this bit does not have meaning unless the corresponding, active mode RCGCWTIMER, SCGCWTIMER or DCGCWTIMER bit is cleared.</p> <p>Value Description</p> <p>1 Timer module 1 is powered, but does not receive a clock. In this case, the module is inactive. This configuration provides the second-lowest power consumption of the module because it consumes only leakage current.</p> <p>0 Timer module 1 is not powered and does not receive a clock. In this case, the module's state is not retained. This configuration provides the lowest power consumption state of the module because it consumes no dynamic nor leakage current.</p>
0	P0	R/W	1	<p>32/64-Bit Wide General-Purpose Timer 0 Power Control</p> <p>The value of this bit does not have meaning unless the corresponding, active mode RCGCWTIMER, SCGCWTIMER or DCGCWTIMER bit is cleared.</p> <p>Value Description</p> <p>1 Timer module 0 is powered, but does not receive a clock. In this case, the module is inactive. This configuration provides the second-lowest power consumption of the module because it consumes only leakage current.</p> <p>0 Timer module 0 is not powered and does not receive a clock. In this case, the module's state is not retained. This configuration provides the lowest power consumption state of the module because it consumes no dynamic nor leakage current.</p>

Register 109: Watchdog Timer Peripheral Ready (PRWD), offset 0xA00

The **PRWD** register indicates whether the watchdog modules are ready to be accessed by software following a change in status of power, Run mode clocking, or reset. A power change is initiated if the corresponding **PCWD** bit is changed from 0 to 1. A Run mode clocking change is initiated if the corresponding **RCGCWD** bit is changed. A reset change is initiated if the corresponding **SRWD** bit is changed from 0 to 1.

The **PRWD** bit is cleared on any of the above events and is not set again until the module is completely powered, enabled, and internally reset.

Watchdog Timer Peripheral Ready (PRWD)

Base 0x400F.E000

Offset 0xA00

Type R/W, reset 0x0000.0000

	31	30	29	28	27	26	25	24	23	22	21	20	19	18	17	16	
	reserved																
Type	RO	RO	RO	RO	RO	RO	RO	RO	RO	RO	RO	RO	RO	RO	RO	RO	
Reset	0	0	0	0	0	0	0	0	0	0	0	0	0	0	0	0	
	15	14	13	12	11	10	9	8	7	6	5	4	3	2	1	0	
	reserved															R1	R0
Type	RO	RO	RO	RO	RO	RO	RO	RO	RO	RO	RO	RO	RO	RO	RO	R/W	R/W
Reset	0	0	0	0	0	0	0	0	0	0	0	0	0	0	0	0	0

Bit/Field	Name	Type	Reset	Description
31:2	reserved	RO	0	Software should not rely on the value of a reserved bit. To provide compatibility with future products, the value of a reserved bit should be preserved across a read-modify-write operation.
1	R1	R/W	0	Watchdog Timer 1 Peripheral Ready Value Description 1 Watchdog module 1 is ready for access. 0 Watchdog module 1 is not ready for access. It is unlocked, unpowered, or in the process of completing a reset sequence.
0	R0	R/W	0	Watchdog Timer 0 Peripheral Ready Value Description 1 Watchdog module 0 is ready for access. 0 Watchdog module 0 is not ready for access. It is unlocked, unpowered, or in the process of completing a reset sequence.

Register 110: 16/32-Bit General-Purpose Timer Peripheral Ready (PRTIMER), offset 0xA04

The **PRTIMER** register indicates whether the timer modules are ready to be accessed by software following a change in status of power, Run mode clocking, or reset. A power change is initiated if the corresponding **PCTIMER** bit is changed from 0 to 1. A Run mode clocking change is initiated if the corresponding **RCGCTIMER** bit is changed. A reset change is initiated if the corresponding **SRTIMER** bit is changed from 0 to 1.

The **PRTIMER** bit is cleared on any of the above events and is not set again until the module is completely powered, enabled, and internally reset.

16/32-Bit General-Purpose Timer Peripheral Ready (PRTIMER)

Base 0x400F.E000
 Offset 0xA04
 Type R/W, reset 0x0000.0000

	31	30	29	28	27	26	25	24	23	22	21	20	19	18	17	16	
	reserved																
Type	RO	RO	RO	RO	RO	RO	RO	RO	RO	RO	RO	RO	RO	RO	RO	RO	
Reset	0	0	0	0	0	0	0	0	0	0	0	0	0	0	0	0	
	15	14	13	12	11	10	9	8	7	6	5	4	3	2	1	0	
	reserved											R5	R4	R3	R2	R1	R0
Type	RO	RO	RO	RO	RO	RO	RO	RO	RO	RO	R/W	R/W	R/W	R/W	R/W	R/W	
Reset	0	0	0	0	0	0	0	0	0	0	0	0	0	0	0	0	

Bit/Field	Name	Type	Reset	Description
31:6	reserved	RO	0	Software should not rely on the value of a reserved bit. To provide compatibility with future products, the value of a reserved bit should be preserved across a read-modify-write operation.
5	R5	R/W	0	16/32-Bit General-Purpose Timer 5 Peripheral Ready Value Description 1 16/32-bit timer module 5 is ready for access. 0 16/32-bit timer module 5 is not ready for access. It is unlocked, unpowered, or in the process of completing a reset sequence.
4	R4	R/W	0	16/32-Bit General-Purpose Timer 4 Peripheral Ready Value Description 1 16/32-bit timer module 4 is ready for access. 0 16/32-bit timer module 4 is not ready for access. It is unlocked, unpowered, or in the process of completing a reset sequence.
3	R3	R/W	0	16/32-Bit General-Purpose Timer 3 Peripheral Ready Value Description 1 16/32-bit timer module 3 is ready for access. 0 16/32-bit timer module 3 is not ready for access. It is unlocked, unpowered, or in the process of completing a reset sequence.

Bit/Field	Name	Type	Reset	Description
2	R2	R/W	0	16/32-Bit General-Purpose Timer 2 Peripheral Ready Value Description 1 16/32-bit timer module 2 is ready for access. 0 16/32-bit timer module 2 is not ready for access. It is unlocked, unpowered, or in the process of completing a reset sequence.
1	R1	R/W	0	16/32-Bit General-Purpose Timer 1 Peripheral Ready Value Description 1 16/32-bit timer module 1 is ready for access. 0 16/32-bit timer module 1 is not ready for access. It is unlocked, unpowered, or in the process of completing a reset sequence.
0	R0	R/W	0	16/32-Bit General-Purpose Timer 0 Peripheral Ready Value Description 1 16/32-bit timer module 0 is ready for access. 0 16/32-bit timer module 0 is not ready for access. It is unlocked, unpowered, or in the process of completing a reset sequence.

Register 111: General-Purpose Input/Output Peripheral Ready (PRGPIO), offset 0xA08

The **PRGPIO** register indicates whether the GPIO modules are ready to be accessed by software following a change in status of power, Run mode clocking, or reset. A power change is initiated if the corresponding **PCGPIO** bit is changed from 0 to 1. A Run mode clocking change is initiated if the corresponding **RCGCGPIO** bit is changed. A reset change is initiated if the corresponding **SRGPIO** bit is changed from 0 to 1.

The **PRGPIO** bit is cleared on any of the above events and is not set again until the module is completely powered, enabled, and internally reset.

General-Purpose Input/Output Peripheral Ready (PRGPIO)

Base 0x400F.E000
 Offset 0xA08
 Type R/W, reset 0x0000.0000

	31	30	29	28	27	26	25	24	23	22	21	20	19	18	17	16	
	reserved																
Type	RO	RO	RO	RO	RO	RO	RO	RO	RO	RO	RO	RO	RO	RO	RO	RO	
Reset	0	0	0	0	0	0	0	0	0	0	0	0	0	0	0	0	
	15	14	13	12	11	10	9	8	7	6	5	4	3	2	1	0	
	reserved										R6	R5	R4	R3	R2	R1	R0
Type	RO	RO	RO	RO	RO	RO	RO	RO	RO	R/W	R/W	R/W	R/W	R/W	R/W	R/W	
Reset	0	0	0	0	0	0	0	0	0	0	0	0	0	0	0	0	

Bit/Field	Name	Type	Reset	Description
31:7	reserved	RO	0	Software should not rely on the value of a reserved bit. To provide compatibility with future products, the value of a reserved bit should be preserved across a read-modify-write operation.
6	R6	R/W	0	GPIO Port G Peripheral Ready Value Description 1 GPIO Port G is ready for access. 0 GPIO Port G is not ready for access. It is unlocked, unpowered, or in the process of completing a reset sequence.
5	R5	R/W	0	GPIO Port F Peripheral Ready Value Description 1 GPIO Port F is ready for access. 0 GPIO Port F is not ready for access. It is unlocked, unpowered, or in the process of completing a reset sequence.
4	R4	R/W	0	GPIO Port E Peripheral Ready Value Description 1 GPIO Port E is ready for access. 0 GPIO Port E is not ready for access. It is unlocked, unpowered, or in the process of completing a reset sequence.

Bit/Field	Name	Type	Reset	Description
3	R3	R/W	0	GPIO Port D Peripheral Ready Value Description 1 GPIO Port D is ready for access. 0 GPIO Port D is not ready for access. It is unlocked, unpowered, or in the process of completing a reset sequence.
2	R2	R/W	0	GPIO Port C Peripheral Ready Value Description 1 GPIO Port C is ready for access. 0 GPIO Port C is not ready for access. It is unlocked, unpowered, or in the process of completing a reset sequence.
1	R1	R/W	0	GPIO Port B Peripheral Ready Value Description 1 GPIO Port B is ready for access. 0 GPIO Port B is not ready for access. It is unlocked, unpowered, or in the process of completing a reset sequence.
0	R0	R/W	0	GPIO Port A Peripheral Ready Value Description 1 GPIO Port A is ready for access. 0 GPIO Port A is not ready for access. It is unlocked, unpowered, or in the process of completing a reset sequence.

Register 112: Micro Direct Memory Access Peripheral Ready (PRDMA), offset 0xA0C

The **PRDMA** register indicates whether the μ DMA module is ready to be accessed by software following a change in status of power, Run mode clocking, or reset. A power change is initiated if the corresponding **PCDMA** bit is changed from 0 to 1. A Run mode clocking change is initiated if the corresponding **RCGCDMA** bit is changed. A reset change is initiated if the corresponding **SRDMA** bit is changed from 0 to 1.

The **PRDMA** bit is cleared on any of the above events and is not set again until the module is completely powered, enabled, and internally reset.

Micro Direct Memory Access Peripheral Ready (PRDMA)

Base 0x400F.E000
 Offset 0xA0C
 Type R/W, reset 0x0000.0000

	31	30	29	28	27	26	25	24	23	22	21	20	19	18	17	16
	reserved															
Type	RO	RO	RO	RO	RO	RO	RO	RO	RO	RO	RO	RO	RO	RO	RO	RO
Reset	0	0	0	0	0	0	0	0	0	0	0	0	0	0	0	0
	15	14	13	12	11	10	9	8	7	6	5	4	3	2	1	0
	reserved															RO
Type	RO	RO	RO	RO	RO	RO	RO	RO	RO	RO	RO	RO	RO	RO	RO	R/W
Reset	0	0	0	0	0	0	0	0	0	0	0	0	0	0	0	0

Bit/Field	Name	Type	Reset	Description
31:1	reserved	RO	0	Software should not rely on the value of a reserved bit. To provide compatibility with future products, the value of a reserved bit should be preserved across a read-modify-write operation.
0	R0	R/W	0	μ DMA Module Peripheral Ready
Value Description				
1	The μ DMA module is ready for access.			
0	The μ DMA module is not ready for access. It is unclocked, unpowered, or in the process of completing a reset sequence.			

Register 113: Universal Asynchronous Receiver/Transmitter Peripheral Ready (PRUART), offset 0xA18

The **PRUART** register indicates whether the UART modules are ready to be accessed by software following a change in status of power, Run mode clocking, or reset. A power change is initiated if the corresponding **PCUART** bit is changed from 0 to 1. A Run mode clocking change is initiated if the corresponding **RCGCUART** bit is changed. A reset change is initiated if the corresponding **SRUART** bit is changed from 0 to 1.

The **PRUART** bit is cleared on any of the above events and is not set again until the module is completely powered, enabled, and internally reset.

Universal Asynchronous Receiver/Transmitter Peripheral Ready (PRUART)

Base 0x400F.E000

Offset 0xA18

Type R/W, reset 0x0000.0000

	31	30	29	28	27	26	25	24	23	22	21	20	19	18	17	16
	reserved															
Type	RO	RO	RO	RO	RO	RO	RO	RO	RO	RO	RO	RO	RO	RO	RO	RO
Reset	0	0	0	0	0	0	0	0	0	0	0	0	0	0	0	0
	15	14	13	12	11	10	9	8	7	6	5	4	3	2	1	0
	reserved								R7	R6	R5	R4	R3	R2	R1	R0
Type	RO	RO	RO	RO	RO	RO	RO	RO	R/W	R/W	R/W	R/W	R/W	R/W	R/W	R/W
Reset	0	0	0	0	0	0	0	0	0	0	0	0	0	0	0	0

Bit/Field	Name	Type	Reset	Description
31:8	reserved	RO	0	Software should not rely on the value of a reserved bit. To provide compatibility with future products, the value of a reserved bit should be preserved across a read-modify-write operation.
7	R7	R/W	0	UART Module 7 Peripheral Ready Value Description 1 UART module 7 is ready for access. 0 UART module 7 is not ready for access. It is unlocked, unpowered, or in the process of completing a reset sequence.
6	R6	R/W	0	UART Module 6 Peripheral Ready Value Description 1 UART module 6 is ready for access. 0 UART module 6 is not ready for access. It is unlocked, unpowered, or in the process of completing a reset sequence.
5	R5	R/W	0	UART Module 5 Peripheral Ready Value Description 1 UART module 5 is ready for access. 0 UART module 5 is not ready for access. It is unlocked, unpowered, or in the process of completing a reset sequence.

Bit/Field	Name	Type	Reset	Description
4	R4	R/W	0	UART Module 4 Peripheral Ready Value Description 1 UART module 4 is ready for access. 0 UART module 4 is not ready for access. It is unlocked, unpowered, or in the process of completing a reset sequence.
3	R3	R/W	0	UART Module 3 Peripheral Ready Value Description 1 UART module 3 is ready for access. 0 UART module 3 is not ready for access. It is unlocked, unpowered, or in the process of completing a reset sequence.
2	R2	R/W	0	UART Module 2 Peripheral Ready Value Description 1 UART module 2 is ready for access. 0 UART module 2 is not ready for access. It is unlocked, unpowered, or in the process of completing a reset sequence.
1	R1	R/W	0	UART Module 1 Peripheral Ready Value Description 1 UART module 1 is ready for access. 0 UART module 1 is not ready for access. It is unlocked, unpowered, or in the process of completing a reset sequence.
0	R0	R/W	0	UART Module 0 Peripheral Ready Value Description 1 UART module 0 is ready for access. 0 UART module 0 is not ready for access. It is unlocked, unpowered, or in the process of completing a reset sequence.

Register 114: Synchronous Serial Interface Peripheral Ready (PRSSI), offset 0xA1C

The **PRSSI** register indicates whether the SSI modules are ready to be accessed by software following a change in status of power, Run mode clocking, or reset. A power change is initiated if the corresponding **PCSSI** bit is changed from 0 to 1. A Run mode clocking change is initiated if the corresponding **RCGCSI** bit is changed. A reset change is initiated if the corresponding **SRSSI** bit is changed from 0 to 1.

The **PRSSI** bit is cleared on any of the above events and is not set again until the module is completely powered, enabled, and internally reset.

Synchronous Serial Interface Peripheral Ready (PRSSI)

Base 0x400F.E000

Offset 0xA1C

Type R/W, reset 0x0000.0000

	31	30	29	28	27	26	25	24	23	22	21	20	19	18	17	16	
	reserved																
Type	RO	RO	RO	RO	RO	RO	RO	RO	RO	RO	RO	RO	RO	RO	RO	RO	
Reset	0	0	0	0	0	0	0	0	0	0	0	0	0	0	0	0	
	15	14	13	12	11	10	9	8	7	6	5	4	3	2	1	0	
	reserved												R3	R2	R1	R0	
Type	RO	RO	RO	RO	RO	RO	RO	RO	RO	RO	RO	RO	RO	R/W	R/W	R/W	R/W
Reset	0	0	0	0	0	0	0	0	0	0	0	0	0	0	0	0	0

Bit/Field	Name	Type	Reset	Description
31:4	reserved	RO	0	Software should not rely on the value of a reserved bit. To provide compatibility with future products, the value of a reserved bit should be preserved across a read-modify-write operation.
3	R3	R/W	0	SSI Module 3 Peripheral Ready Value Description 1 SSI module 3 is ready for access. 0 SSI module 3 is not ready for access. It is unlocked, unpowered, or in the process of completing a reset sequence.
2	R2	R/W	0	SSI Module 2 Peripheral Ready Value Description 1 SSI module 2 is ready for access. 0 SSI module 2 is not ready for access. It is unlocked, unpowered, or in the process of completing a reset sequence.
1	R1	R/W	0	SSI Module 1 Peripheral Ready Value Description 1 SSI module 1 is ready for access. 0 SSI module 1 is not ready for access. It is unlocked, unpowered, or in the process of completing a reset sequence.

Bit/Field	Name	Type	Reset	Description
0	R0	R/W	0	SSI Module 0 Peripheral Ready
				Value Description
				1 SSI module 0 is ready for access.
				0 SSI module 0 is not ready for access. It is unlocked, unpowered, or in the process of completing a reset sequence.

Register 115: Inter-Integrated Circuit Peripheral Ready (PRI2C), offset 0xA20

The **PRI2C** register indicates whether the I²C modules are ready to be accessed by software following a change in status of power, Run mode clocking, or reset. A power change is initiated if the corresponding **PCI2C** bit is changed from 0 to 1. A Run mode clocking change is initiated if the corresponding **RCGCI2C** bit is changed. A reset change is initiated if the corresponding **SRI2C** bit is changed from 0 to 1.

The **PRI2C** bit is cleared on any of the above events and is not set again until the module is completely powered, enabled, and internally reset.

Inter-Integrated Circuit Peripheral Ready (PRI2C)

Base 0x400F.E000
Offset 0xA20
Type R/W, reset 0x0000.0000

	31	30	29	28	27	26	25	24	23	22	21	20	19	18	17	16	
	reserved																
Type	RO	RO	RO	RO	RO	RO	RO	RO	RO	RO	RO	RO	RO	RO	RO	RO	
Reset	0	0	0	0	0	0	0	0	0	0	0	0	0	0	0	0	
	15	14	13	12	11	10	9	8	7	6	5	4	3	2	1	0	
	reserved											R5	R4	R3	R2	R1	R0
Type	RO	RO	RO	RO	RO	RO	RO	RO	RO	RO	RO	R/W	R/W	R/W	R/W	R/W	
Reset	0	0	0	0	0	0	0	0	0	0	0	0	0	0	0	0	

Bit/Field	Name	Type	Reset	Description
31:6	reserved	RO	0	Software should not rely on the value of a reserved bit. To provide compatibility with future products, the value of a reserved bit should be preserved across a read-modify-write operation.
5	R5	R/W	0	I ² C Module 5 Peripheral Ready Value Description 1 I ² C module 5 is ready for access. 0 I ² C module 5 is not ready for access. It is unlocked, unpowered, or in the process of completing a reset sequence.
4	R4	R/W	0	I ² C Module 4 Peripheral Ready Value Description 1 I ² C module 4 is ready for access. 0 I ² C module 4 is not ready for access. It is unlocked, unpowered, or in the process of completing a reset sequence.
3	R3	R/W	0	I ² C Module 3 Peripheral Ready Value Description 1 I ² C module 3 is ready for access. 0 I ² C module 3 is not ready for access. It is unlocked, unpowered, or in the process of completing a reset sequence.

Bit/Field	Name	Type	Reset	Description
2	R2	R/W	0	I ² C Module 2 Peripheral Ready Value Description 1 I ² C module 2 is ready for access. 0 I ² C module 2 is not ready for access. It is unlocked, unpowered, or in the process of completing a reset sequence.
1	R1	R/W	0	I ² C Module 1 Peripheral Ready Value Description 1 I ² C module 1 is ready for access. 0 I ² C module 1 is not ready for access. It is unlocked, unpowered, or in the process of completing a reset sequence.
0	R0	R/W	0	I ² C Module 0 Peripheral Ready Value Description 1 I ² C module 0 is ready for access. 0 I ² C module 0 is not ready for access. It is unlocked, unpowered, or in the process of completing a reset sequence.

Register 116: Universal Serial Bus Peripheral Ready (PRUSB), offset 0xA28

The **PRUSB** register indicates whether the USB module is ready to be accessed by software following a change in status of power, Run mode clocking, or reset. A power change is initiated if the corresponding **PCUSB** bit is changed from 0 to 1. A Run mode clocking change is initiated if the corresponding **RCGCUSB** bit is changed. A reset change is initiated if the corresponding **SRUSB** bit is changed from 0 to 1.

The **PRUSB** bit is cleared on any of the above events and is not set again until the module is completely powered, enabled, and internally reset.

Universal Serial Bus Peripheral Ready (PRUSB)

Base 0x400F.E000

Offset 0xA28

Type R/W, reset 0x0000.0000

	31	30	29	28	27	26	25	24	23	22	21	20	19	18	17	16
	reserved															
Type	RO	RO	RO	RO	RO	RO	RO	RO	RO	RO	RO	RO	RO	RO	RO	RO
Reset	0	0	0	0	0	0	0	0	0	0	0	0	0	0	0	0
	15	14	13	12	11	10	9	8	7	6	5	4	3	2	1	0
	reserved															RO
Type	RO	RO	RO	RO	RO	RO	RO	RO	RO	RO	RO	RO	RO	RO	RO	R/W
Reset	0	0	0	0	0	0	0	0	0	0	0	0	0	0	0	0

Bit/Field	Name	Type	Reset	Description
31:1	reserved	RO	0	Software should not rely on the value of a reserved bit. To provide compatibility with future products, the value of a reserved bit should be preserved across a read-modify-write operation.
0	R0	R/W	0	USB Module Peripheral Ready
				Value Description
				1 The USB module is ready for access.
				0 The USB module is not ready for access. It is unclocked, unpowered, or in the process of completing a reset sequence.

Register 117: Controller Area Network Peripheral Ready (PRCAN), offset 0xA34

The **PRCAN** register indicates whether the CAN modules are ready to be accessed by software following a change in status of power, Run mode clocking, or reset. A power change is initiated if the corresponding **PCCAN** bit is changed from 0 to 1. A Run mode clocking change is initiated if the corresponding **RCGCCAN** bit is changed. A reset change is initiated if the corresponding **SRCAN** bit is changed from 0 to 1.

The **PRCAN** bit is cleared on any of the above events and is not set again until the module is completely powered, enabled, and internally reset.

Controller Area Network Peripheral Ready (PRCAN)

Base 0x400F.E000
 Offset 0xA34
 Type R/W, reset 0x0000.0000

	31	30	29	28	27	26	25	24	23	22	21	20	19	18	17	16	
	reserved																
Type	RO	RO	RO	RO	RO	RO	RO	RO	RO	RO	RO	RO	RO	RO	RO	RO	
Reset	0	0	0	0	0	0	0	0	0	0	0	0	0	0	0	0	
	15	14	13	12	11	10	9	8	7	6	5	4	3	2	1	0	
	reserved															R1	R0
Type	RO	RO	RO	RO	RO	RO	RO	RO	RO	RO	RO	RO	RO	RO	RO	R/W	R/W
Reset	0	0	0	0	0	0	0	0	0	0	0	0	0	0	0	0	0

Bit/Field	Name	Type	Reset	Description
31:2	reserved	RO	0	Software should not rely on the value of a reserved bit. To provide compatibility with future products, the value of a reserved bit should be preserved across a read-modify-write operation.
1	R1	R/W	0	CAN Module 1 Peripheral Ready Value Description 1 CAN module 1 is ready for access. 0 CAN module 1 is not ready for access. It is unlocked, unpowered, or in the process of completing a reset sequence.
0	R0	R/W	0	CAN Module 0 Peripheral Ready Value Description 1 CAN module 0 is ready for access. 0 CAN module 0 is not ready for access. It is unlocked, unpowered, or in the process of completing a reset sequence.

Register 118: Analog-to-Digital Converter Peripheral Ready (PRADC), offset 0xA38

The **PRADC** register indicates whether the ADC modules are ready to be accessed by software following a change in status of power, Run mode clocking, or reset. A power change is initiated if the corresponding **PCADC** bit is changed from 0 to 1. A Run mode clocking change is initiated if the corresponding **RCGCADC** bit is changed. A reset change is initiated if the corresponding **SRADC** bit is changed from 0 to 1.

The **PRADC** bit is cleared on any of the above events and is not set again until the module is completely powered, enabled, and internally reset.

Analog-to-Digital Converter Peripheral Ready (PRADC)

Base 0x400F.E000

Offset 0xA38

Type R/W, reset 0x0000.0000

	31	30	29	28	27	26	25	24	23	22	21	20	19	18	17	16	
	reserved																
Type	RO	RO	RO	RO	RO	RO	RO	RO	RO	RO	RO	RO	RO	RO	RO	RO	
Reset	0	0	0	0	0	0	0	0	0	0	0	0	0	0	0	0	
	15	14	13	12	11	10	9	8	7	6	5	4	3	2	1	0	
	reserved															R1	R0
Type	RO	RO	RO	RO	RO	RO	RO	RO	RO	RO	RO	RO	RO	RO	RO	R/W	R/W
Reset	0	0	0	0	0	0	0	0	0	0	0	0	0	0	0	0	0

Bit/Field	Name	Type	Reset	Description
31:2	reserved	RO	0	Software should not rely on the value of a reserved bit. To provide compatibility with future products, the value of a reserved bit should be preserved across a read-modify-write operation.
1	R1	R/W	0	ADC Module 1 Peripheral Ready Value Description 1 ADC module 1 is ready for access. 0 ADC module 1 is not ready for access. It is unlocked, unpowered, or in the process of completing a reset sequence.
0	R0	R/W	0	ADC Module 0 Peripheral Ready Value Description 1 ADC module 0 is ready for access. 0 ADC module 0 is not ready for access. It is unlocked, unpowered, or in the process of completing a reset sequence.

Register 119: Analog Comparator Peripheral Ready (PRACMP), offset 0xA3C

The **PRACMP** register indicates whether the analog comparator module is ready to be accessed by software following a change in status of power, Run mode clocking, or reset. A power change is initiated if the corresponding **PCACMP** bit is changed from 0 to 1. A Run mode clocking change is initiated if the corresponding **RCGCACMP** bit is changed. A reset change is initiated if the corresponding **SRACMP** bit is changed from 0 to 1.

The **PRACMP** bit is cleared on any of the above events and is not set again until the module is completely powered, enabled, and internally reset.

Analog Comparator Peripheral Ready (PRACMP)

Base 0x400F.E000
 Offset 0xA3C
 Type R/W, reset 0x0000.0000

	31	30	29	28	27	26	25	24	23	22	21	20	19	18	17	16
	reserved															
Type	RO	RO	RO	RO	RO	RO	RO	RO	RO	RO	RO	RO	RO	RO	RO	RO
Reset	0	0	0	0	0	0	0	0	0	0	0	0	0	0	0	0
	15	14	13	12	11	10	9	8	7	6	5	4	3	2	1	0
	reserved															R0
Type	RO	RO	RO	RO	RO	RO	RO	RO	RO	RO	RO	RO	RO	RO	RO	R/W
Reset	0	0	0	0	0	0	0	0	0	0	0	0	0	0	0	0

Bit/Field	Name	Type	Reset	Description
31:1	reserved	RO	0	Software should not rely on the value of a reserved bit. To provide compatibility with future products, the value of a reserved bit should be preserved across a read-modify-write operation.
0	R0	R/W	0	Analog Comparator Module 0 Peripheral Ready

Value	Description
1	The analog comparator module is ready for access.
0	The analog comparator module is not ready for access. It is unlocked, unpowered, or in the process of completing a reset sequence.

Register 120: Pulse Width Modulator Peripheral Ready (PRPWM), offset 0xA40

The **PRPWM** register indicates whether the PWM modules are ready to be accessed by software following a change in status of power, Run mode clocking, or reset. A power change is initiated if the corresponding **PCPWM** bit is changed from 0 to 1. A Run mode clocking change is initiated if the corresponding **RCGCPWM** bit is changed. A reset change is initiated if the corresponding **SRPWM** bit is changed from 0 to 1.

The **PRPWM** bit is cleared on any of the above events and is not set again until the module is completely powered, enabled, and internally reset.

Pulse Width Modulator Peripheral Ready (PRPWM)

Base 0x400F.E000

Offset 0xA40

Type R/W, reset 0x0000.0000

	31	30	29	28	27	26	25	24	23	22	21	20	19	18	17	16	
	reserved																
Type	RO	RO	RO	RO	RO	RO	RO	RO	RO	RO	RO	RO	RO	RO	RO	RO	
Reset	0	0	0	0	0	0	0	0	0	0	0	0	0	0	0	0	
	15	14	13	12	11	10	9	8	7	6	5	4	3	2	1	0	
	reserved															R1	R0
Type	RO	RO	RO	RO	RO	RO	RO	RO	RO	RO	RO	RO	RO	RO	RO	R/W	R/W
Reset	0	0	0	0	0	0	0	0	0	0	0	0	0	0	0	0	0

Bit/Field	Name	Type	Reset	Description
31:2	reserved	RO	0	Software should not rely on the value of a reserved bit. To provide compatibility with future products, the value of a reserved bit should be preserved across a read-modify-write operation.
1	R1	R/W	0	PWM Module 1 Peripheral Ready Value Description 1 PWM module 1 is ready for access. 0 PWM module 1 is not ready for access. It is unlocked, unpowered, or in the process of completing a reset sequence.
0	R0	R/W	0	PWM Module 0 Peripheral Ready Value Description 1 PWM module 0 is ready for access. 0 PWM module 0 is not ready for access. It is unlocked, unpowered, or in the process of completing a reset sequence.

Register 121: Quadrature Encoder Interface Peripheral Ready (PRQEI), offset 0xA44

The **PRQEI** register indicates whether the QEI modules are ready to be accessed by software following a change in status of power, Run mode clocking, or reset. A power change is initiated if the corresponding **PCQEI** bit is changed from 0 to 1. A Run mode clocking change is initiated if the corresponding **RCGCQEI** bit is changed. A reset change is initiated if the corresponding **SRQEI** bit is changed from 0 to 1.

The **PRQEI** bit is cleared on any of the above events and is not set again until the module is completely powered, enabled, and internally reset.

Quadrature Encoder Interface Peripheral Ready (PRQEI)

Base 0x400F.E000
 Offset 0xA44
 Type R/W, reset 0x0000.0000

	31	30	29	28	27	26	25	24	23	22	21	20	19	18	17	16	
	reserved																
Type	RO	RO	RO	RO	RO	RO	RO	RO	RO	RO	RO	RO	RO	RO	RO	RO	
Reset	0	0	0	0	0	0	0	0	0	0	0	0	0	0	0	0	
	15	14	13	12	11	10	9	8	7	6	5	4	3	2	1	0	
	reserved															R1	R0
Type	RO	RO	RO	RO	RO	RO	RO	RO	RO	RO	RO	RO	RO	RO	RO	R/W	R/W
Reset	0	0	0	0	0	0	0	0	0	0	0	0	0	0	0	0	0

Bit/Field	Name	Type	Reset	Description
31:2	reserved	RO	0	Software should not rely on the value of a reserved bit. To provide compatibility with future products, the value of a reserved bit should be preserved across a read-modify-write operation.
1	R1	R/W	0	QEI Module 1 Peripheral Ready Value Description 1 QEI module 1 is ready for access. 0 QEI module 1 is not ready for access. It is unclocked, unpowered, or in the process of completing a reset sequence.
0	R0	R/W	0	QEI Module 0 Peripheral Ready Value Description 1 QEI module 0 is ready for access. 0 QEI module 0 is not ready for access. It is unclocked, unpowered, or in the process of completing a reset sequence.

Register 122: EEPROM Peripheral Ready (PREEPROM), offset 0xA58

The **PREEPROM** register indicates whether the EEPROM module is ready to be accessed by software following a change in status of power, Run mode clocking, or reset. A power change is initiated if the corresponding **PCEEPROM** bit is changed from 0 to 1. A Run mode clocking change is initiated if the corresponding **RCGCEEPROM** bit is changed. A reset change is initiated if the corresponding **SREEPROM** bit is changed from 0 to 1.

The **PREEPROM** bit is cleared on any of the above events and is not set again until the module is completely powered, enabled, and internally reset.

EEPROM Peripheral Ready (PREEPROM)

Base 0x400F.E000

Offset 0xA58

Type R/W, reset 0x0000.0000

	31	30	29	28	27	26	25	24	23	22	21	20	19	18	17	16
	reserved															
Type	RO	RO	RO	RO	RO	RO	RO	RO	RO	RO	RO	RO	RO	RO	RO	RO
Reset	0	0	0	0	0	0	0	0	0	0	0	0	0	0	0	0
	15	14	13	12	11	10	9	8	7	6	5	4	3	2	1	0
	reserved															RO
Type	RO	RO	RO	RO	RO	RO	RO	RO	RO	RO	RO	RO	RO	RO	RO	R/W
Reset	0	0	0	0	0	0	0	0	0	0	0	0	0	0	0	0

Bit/Field	Name	Type	Reset	Description
31:1	reserved	RO	0	Software should not rely on the value of a reserved bit. To provide compatibility with future products, the value of a reserved bit should be preserved across a read-modify-write operation.
0	R0	R/W	0	EEPROM Module Peripheral Ready
				Value Description
				1 The EEPROM module is ready for access.
				0 The EEPROM module is not ready for access. It is unclocked, unpowered, or in the process of completing a reset sequence.

Register 123: 32/64-Bit Wide General-Purpose Timer Peripheral Ready (PRWTIMER), offset 0xA5C

The **PRWTIMER** register indicates whether the timer modules are ready to be accessed by software following a change in status of power, Run mode clocking, or reset. A power change is initiated if the corresponding **PCWTIMER** bit is changed from 0 to 1. A Run mode clocking change is initiated if the corresponding **RCGCWTIMER** bit is changed. A reset change is initiated if the corresponding **SRWTIMER** bit is changed from 0 to 1.

The **PRWTIMER** bit is cleared on any of the above events and is not set again until the module is completely powered, enabled, and internally reset.

32/64-Bit Wide General-Purpose Timer Peripheral Ready (PRWTIMER)

Base 0x400F.E000
 Offset 0xA5C
 Type R/W, reset 0x0000.0000

	31	30	29	28	27	26	25	24	23	22	21	20	19	18	17	16	
	reserved																
Type	RO	RO	RO	RO	RO	RO	RO	RO	RO	RO	RO	RO	RO	RO	RO	RO	
Reset	0	0	0	0	0	0	0	0	0	0	0	0	0	0	0	0	
	15	14	13	12	11	10	9	8	7	6	5	4	3	2	1	0	
	reserved											R5	R4	R3	R2	R1	R0
Type	RO	RO	RO	RO	RO	RO	RO	RO	RO	RO	R/W	R/W	R/W	R/W	R/W	R/W	
Reset	0	0	0	0	0	0	0	0	0	0	0	0	0	0	0	0	

Bit/Field	Name	Type	Reset	Description
31:6	reserved	RO	0	Software should not rely on the value of a reserved bit. To provide compatibility with future products, the value of a reserved bit should be preserved across a read-modify-write operation.
5	R5	R/W	0	32/64-Bit Wide General-Purpose Timer 5 Peripheral Ready Value Description 1 32/64-bit wide timer module 5 is ready for access. 0 32/64-bit wide timer module 5 is not ready for access. It is unlocked, unpowered, or in the process of completing a reset sequence.
4	R4	R/W	0	32/64-Bit Wide General-Purpose Timer 4 Peripheral Ready Value Description 1 32/64-bit wide timer module 4 is ready for access. 0 32/64-bit wide timer module 4 is not ready for access. It is unlocked, unpowered, or in the process of completing a reset sequence.
3	R3	R/W	0	32/64-Bit Wide General-Purpose Timer 3 Peripheral Ready Value Description 1 32/64-bit wide timer module 3 is ready for access. 0 32/64-bit wide timer module 3 is not ready for access. It is unlocked, unpowered, or in the process of completing a reset sequence.

Bit/Field	Name	Type	Reset	Description
2	R2	R/W	0	32/64-Bit Wide General-Purpose Timer 2 Peripheral Ready Value Description 1 32/64-bit wide timer module 2 is ready for access. 0 32/64-bit wide timer module 2 is not ready for access. It is unlocked, unpowered, or in the process of completing a reset sequence.
1	R1	R/W	0	32/64-Bit Wide General-Purpose Timer 1 Peripheral Ready Value Description 1 32/64-bit wide timer module 1 is ready for access. 0 32/64-bit wide timer module 1 is not ready for access. It is unlocked, unpowered, or in the process of completing a reset sequence.
0	R0	R/W	0	32/64-Bit Wide General-Purpose Timer 0 Peripheral Ready Value Description 1 32/64-bit wide timer module 0 is ready for access. 0 32/64-bit wide timer module 0 is not ready for access. It is unlocked, unpowered, or in the process of completing a reset sequence.

5.6 System Control Legacy Register Descriptions

All addresses given are relative to the System Control base address of 0x400F.E000.

Important: Register in this section are provided for legacy software support only; registers in “System Control Register Descriptions” on page 235 should be used instead.

Register 124: Device Capabilities 0 (DC0), offset 0x008

This legacy register is predefined by the part and can be used to verify features.

Important: This register is provided for legacy software support only.

The **Flash Size (FSIZE)** and **SRAM Size (SSIZE)** registers should be used to determine this microcontroller's memory sizes. A read of **DC0** correctly identifies legacy memory sizes but software must use **FSIZE** and **SSIZE** for memory sizes that are not listed below.

Device Capabilities 0 (DC0)

Base 0x400F.E000
 Offset 0x008
 Type RO, reset 0x007F.007F

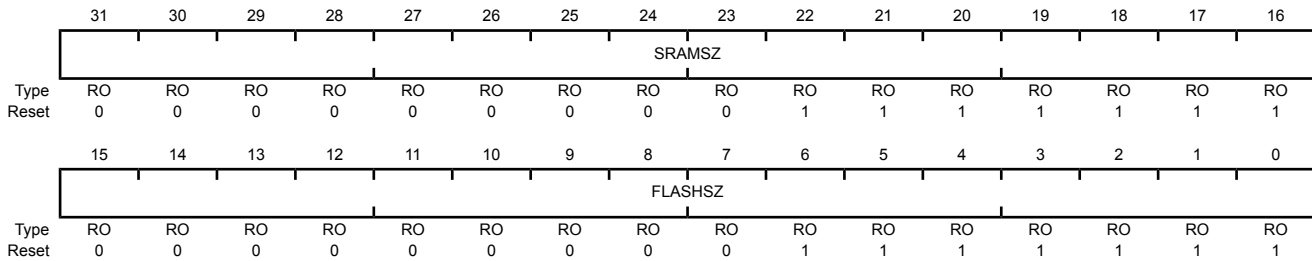

Bit/Field	Name	Type	Reset	Description
31:16	SRAMSZ	RO	0x7F	SRAM Size Indicates the size of the on-chip SRAM.
	Value	Description		
	0x7	2 KB of SRAM		
	0xF	4 KB of SRAM		
	0x17	6 KB of SRAM		
	0x1F	8 KB of SRAM		
	0x2F	12 KB of SRAM		
	0x3F	16 KB of SRAM		
	0x4F	20 KB of SRAM		
	0x5F	24 KB of SRAM		
	0x7F	32 KB of SRAM		

Bit/Field	Name	Type	Reset	Description
15:0	FLASHSZ	RO	0x7F	Flash Size Indicates the size of the on-chip Flash memory.
				Value Description
				0x3 8 KB of Flash
				0x7 16 KB of Flash
				0xF 32 KB of Flash
				0x1F 64 KB of Flash
				0x2F 96 KB of Flash
				0x3F 128 KB of Flash
				0x5F 192 KB of Flash
				0x7F 256 KB of Flash

Register 125: Device Capabilities 1 (DC1), offset 0x010

This register is predefined by the part and can be used to verify features. If any bit is clear in this register, the module is not present. The corresponding bit in the **RCGC0**, **SCGC0**, **DCGC0**, and the peripheral-specific **RCGC**, **SCGC**, and **DCGC** registers cannot be set.

Important: This register is provided for legacy software support only.

The Peripheral Present registers should be used to determine which modules are implemented on this microcontroller. A read of **DC1** correctly identifies if a legacy module is present but software must use the Peripheral Present registers to determine if a module is present that is not supported by the **DCn** registers.

Likewise, the **ADC Peripheral Properties (ADCPP)** register should be used to determine the maximum ADC sample rate and whether the temperature sensor is present. However, to support legacy software, the **MAXADCnSPD** fields and the **TEMPSNS** bit are available. A read of **DC1** correctly identifies the maximum ADC sample rate for legacy rates and whether the temperature sensor is present.

Device Capabilities 1 (DC1)

Base 0x400F.E000
Offset 0x010
Type RO, reset 0x1333.2FBF

	31	30	29	28	27	26	25	24	23	22	21	20	19	18	17	16
	reserved			WDT1	reserved		CAN1	CAN0	reserved		PWM1	PWM0	reserved		ADC1	ADC0
Type	RO	RO	RO	RO	RO	RO	RO	RO	RO	RO	RO	RO	RO	RO	RO	RO
Reset	0	0	0	1	0	0	1	1	0	0	1	1	0	0	1	1
	15	14	13	12	11	10	9	8	7	6	5	4	3	2	1	0
	MINSYSDIV			MAXADC1SPD		MAXADC0SPD		MPU	HIB	TEMPSNS	PLL	WDT0	SWO	SWD	JTAG	
Type	RO	RO	RO	RO	RO	RO	RO	RO	RO	RO	RO	RO	RO	RO	RO	
Reset	0	0	1	0	1	1	1	1	1	0	1	1	1	1	1	

Bit/Field	Name	Type	Reset	Description
31:29	reserved	RO	0	Software should not rely on the value of a reserved bit. To provide compatibility with future products, the value of a reserved bit should be preserved across a read-modify-write operation.
28	WDT1	RO	0x1	Watchdog Timer1 Present When set, indicates that watchdog timer 1 is present.
27:26	reserved	RO	0	Software should not rely on the value of a reserved bit. To provide compatibility with future products, the value of a reserved bit should be preserved across a read-modify-write operation.
25	CAN1	RO	0x1	CAN Module 1 Present When set, indicates that CAN unit 1 is present.
24	CAN0	RO	0x1	CAN Module 0 Present When set, indicates that CAN unit 0 is present.
23:22	reserved	RO	0	Software should not rely on the value of a reserved bit. To provide compatibility with future products, the value of a reserved bit should be preserved across a read-modify-write operation.
21	PWM1	RO	0x1	PWM Module 1 Present When set, indicates that the PWM module is present.

Bit/Field	Name	Type	Reset	Description
20	PWM0	RO	0x1	PWM Module 0 Present When set, indicates that the PWM module is present.
19:18	reserved	RO	0	Software should not rely on the value of a reserved bit. To provide compatibility with future products, the value of a reserved bit should be preserved across a read-modify-write operation.
17	ADC1	RO	0x1	ADC Module 1 Present When set, indicates that ADC module 1 is present.
16	ADC0	RO	0x1	ADC Module 0 Present When set, indicates that ADC module 0 is present
15:12	MINSYSDIV	RO	0x2	System Clock Divider Minimum 4-bit divider value for system clock. The reset value is hardware-dependent. See the RCC register for how to change the system clock divisor using the <i>SYSDIV</i> bit. Value Description 0x1 Specifies an 80-MHz CPU clock with a PLL divider of 2.5. 0x2 Specifies a 66-MHz CPU clock with a PLL divider of 3. 0x3 Specifies a 50-MHz CPU clock with a PLL divider of 4. 0x4 Specifies a 40-MHz CPU clock with a PLL divider of 5. 0x7 Specifies a 25-MHz clock with a PLL divider of 8. 0x9 Specifies a 20-MHz clock with a PLL divider of 10.
11:10	MAXADC1SPD	RO	0x3	Max ADC1 Speed This field indicates the maximum rate at which the ADC samples data. Value Description 0x3 1M samples/second 0x2 500K samples/second 0x1 250K samples/second 0x0 125K samples/second
9:8	MAXADC0SPD	RO	0x3	Max ADC0 Speed This field indicates the maximum rate at which the ADC samples data. Value Description 0x3 1M samples/second 0x2 500K samples/second 0x1 250K samples/second 0x0 125K samples/second
7	MPU	RO	0x1	MPU Present When set, indicates that the Cortex-M4F Memory Protection Unit (MPU) module is present. See the "Cortex-M4F Peripherals" chapter for details on the MPU.

Bit/Field	Name	Type	Reset	Description
6	HIB	RO	0x0	Hibernation Module Present When set, indicates that the Hibernation module is present.
5	TEMPSNS	RO	0x1	Temp Sensor Present When set, indicates that the on-chip temperature sensor is present.
4	PLL	RO	0x1	PLL Present When set, indicates that the on-chip Phase Locked Loop (PLL) is present.
3	WDT0	RO	0x1	Watchdog Timer 0 Present When set, indicates that watchdog timer 0 is present.
2	SWO	RO	0x1	SWO Trace Port Present When set, indicates that the Serial Wire Output (SWO) trace port is present.
1	SWD	RO	0x1	SWD Present When set, indicates that the Serial Wire Debugger (SWD) is present.
0	JTAG	RO	0x1	JTAG Present When set, indicates that the JTAG debugger interface is present.

Register 126: Device Capabilities 2 (DC2), offset 0x014

This register is predefined by the part and can be used to verify features. If any bit is clear in this register, the module is not present. The corresponding bit in the **RCGC1**, **SCGC1**, **DCGC1**, and the peripheral-specific **RCGC**, **SCGC**, and **DCGC** registers registers cannot be set.

Important: This register is provided for legacy software support only.

The Peripheral Present registers should be used to determine which modules are implemented on this microcontroller. A read of **DC2** correctly identifies if a legacy module is present but software must use the Peripheral Present registers to determine if a module is present that is not supported by the **DCn** registers.

Note that the **Analog Comparator Peripheral Present (PPACMP)** register identifies whether the analog comparator module is present. The **Analog Comparator Peripheral Properties (ACMPPP)** register indicates how many analog comparator blocks are present in the module.

Device Capabilities 2 (DC2)

Base 0x400F.E000

Offset 0x014

Type RO, reset 0x030F.F337

	31	30	29	28	27	26	25	24	23	22	21	20	19	18	17	16
	reserved	EPI0	reserved	I2S0	reserved	COMP2	COMP1	COMP0	reserved			TIMER3	TIMER2	TIMER1	TIMER0	
Type	RO	RO	RO	RO	RO	RO	RO	RO	RO	RO	RO	RO	RO	RO	RO	RO
Reset	0	0	0	0	0	0	1	1	0	0	0	0	1	1	1	1
	15	14	13	12	11	10	9	8	7	6	5	4	3	2	1	0
	I2C1HS	I2C1	I2C0HS	I2C0	reserved		QEI1	QEI0	reserved		SSI1	SSI0	reserved	UART2	UART1	UART0
Type	RO	RO	RO	RO	RO	RO	RO	RO	RO	RO	RO	RO	RO	RO	RO	RO
Reset	1	1	1	1	0	0	1	1	0	0	1	1	0	1	1	1

Bit/Field	Name	Type	Reset	Description
31	reserved	RO	0	Software should not rely on the value of a reserved bit. To provide compatibility with future products, the value of a reserved bit should be preserved across a read-modify-write operation.
30	EPI0	RO	0x0	EPI Module 0 Present When set, indicates that EPI module 0 is present.
29	reserved	RO	0	Software should not rely on the value of a reserved bit. To provide compatibility with future products, the value of a reserved bit should be preserved across a read-modify-write operation.
28	I2S0	RO	0x0	I2S Module 0 Present When set, indicates that I2S module 0 is present.
27	reserved	RO	0	Software should not rely on the value of a reserved bit. To provide compatibility with future products, the value of a reserved bit should be preserved across a read-modify-write operation.
26	COMP2	RO	0x0	Analog Comparator 2 Present When set, indicates that analog comparator 2 is present.
25	COMP1	RO	0x1	Analog Comparator 1 Present When set, indicates that analog comparator 1 is present.

Bit/Field	Name	Type	Reset	Description
24	COMP0	RO	0x1	Analog Comparator 0 Present When set, indicates that analog comparator 0 is present.
23:20	reserved	RO	0	Software should not rely on the value of a reserved bit. To provide compatibility with future products, the value of a reserved bit should be preserved across a read-modify-write operation.
19	TIMER3	RO	0x1	Timer Module 3 Present When set, indicates that General-Purpose Timer module 3 is present.
18	TIMER2	RO	0x1	Timer Module 2 Present When set, indicates that General-Purpose Timer module 2 is present.
17	TIMER1	RO	0x1	Timer Module 1 Present When set, indicates that General-Purpose Timer module 1 is present.
16	TIMER0	RO	0x1	Timer Module 0 Present When set, indicates that General-Purpose Timer module 0 is present.
15	I2C1HS	RO	0x1	I2C Module 1 Speed When set, indicates that I2C module 1 can operate in high-speed mode.
14	I2C1	RO	0x1	I2C Module 1 Present When set, indicates that I2C module 1 is present.
13	I2C0HS	RO	0x1	I2C Module 0 Speed When set, indicates that I2C module 0 can operate in high-speed mode.
12	I2C0	RO	0x1	I2C Module 0 Present When set, indicates that I2C module 0 is present.
11:10	reserved	RO	0	Software should not rely on the value of a reserved bit. To provide compatibility with future products, the value of a reserved bit should be preserved across a read-modify-write operation.
9	QEI1	RO	0x1	QEI Module 1 Present When set, indicates that QEI module 1 is present.
8	QEI0	RO	0x1	QEI Module 0 Present When set, indicates that QEI module 0 is present.
7:6	reserved	RO	0	Software should not rely on the value of a reserved bit. To provide compatibility with future products, the value of a reserved bit should be preserved across a read-modify-write operation.
5	SSI1	RO	0x1	SSI Module 1 Present When set, indicates that SSI module 1 is present.
4	SSI0	RO	0x1	SSI Module 0 Present When set, indicates that SSI module 0 is present.
3	reserved	RO	0	Software should not rely on the value of a reserved bit. To provide compatibility with future products, the value of a reserved bit should be preserved across a read-modify-write operation.

Bit/Field	Name	Type	Reset	Description
2	UART2	RO	0x1	UART Module 2 Present When set, indicates that UART module 2 is present.
1	UART1	RO	0x1	UART Module 1 Present When set, indicates that UART module 1 is present.
0	UART0	RO	0x1	UART Module 0 Present When set, indicates that UART module 0 is present.

Register 127: Device Capabilities 3 (DC3), offset 0x018

This register is predefined by the part and can be used to verify features. If any bit is clear in this register, the feature is not present.

Important: This register is provided for legacy software support only.

For some modules, the peripheral-resident Peripheral Properties registers should be used to determine which pins are available on this microcontroller. A read of **DC3** correctly identifies if a legacy pin is present but software must use the Peripheral Properties registers to determine if a pin is present that is not supported by the **DCn** registers.

Device Capabilities 3 (DC3)

Base 0x400F.E000

Offset 0x018

Type RO, reset 0xBFFF.8FFF

	31	30	29	28	27	26	25	24	23	22	21	20	19	18	17	16
	32KHZ	reserved	CCP5	CCP4	CCP3	CCP2	CCP1	CCP0	ADC0AIN7	ADC0AIN6	ADC0AIN5	ADC0AIN4	ADC0AIN3	ADC0AIN2	ADC0AIN1	ADC0AIN0
Type	RO	RO	RO	RO	RO	RO	RO	RO	RO	RO	RO	RO	RO	RO	RO	RO
Reset	1	0	1	1	1	1	1	1	1	1	1	1	1	1	1	1
	15	14	13	12	11	10	9	8	7	6	5	4	3	2	1	0
	PWMFAULT	C2O	C2PLUS	C2MINUS	C1O	C1PLUS	C1MINUS	C0O	C0PLUS	C0MINUS	PWM5	PWM4	PWM3	PWM2	PWM1	PWM0
Type	RO	RO	RO	RO	RO	RO	RO	RO	RO	RO	RO	RO	RO	RO	RO	RO
Reset	1	0	0	0	1	1	1	1	1	1	1	1	1	1	1	1

Bit/Field	Name	Type	Reset	Description
31	32KHZ	RO	0x1	32KHz Input Clock Available When set, indicates an even CCP pin is present and can be used as a 32-KHz input clock. Note: The GPTMPP register does not provide this information.
30	reserved	RO	0	Software should not rely on the value of a reserved bit. To provide compatibility with future products, the value of a reserved bit should be preserved across a read-modify-write operation.
29	CCP5	RO	0x1	CCP5 Pin Present When set, indicates that Capture/Compare/PWM pin 5 is present. Note: The GPTMPP register does not provide this information.
28	CCP4	RO	0x1	CCP4 Pin Present When set, indicates that Capture/Compare/PWM pin 4 is present. Note: The GPTMPP register does not provide this information.
27	CCP3	RO	0x1	CCP3 Pin Present When set, indicates that Capture/Compare/PWM pin 3 is present. Note: The GPTMPP register does not provide this information.
26	CCP2	RO	0x1	CCP2 Pin Present When set, indicates that Capture/Compare/PWM pin 2 is present. Note: The GPTMPP register does not provide this information.

Bit/Field	Name	Type	Reset	Description
25	CCP1	RO	0x1	CCP1 Pin Present When set, indicates that Capture/Compare/PWM pin 1 is present. Note: The GPTMPP register does not provide this information.
24	CCP0	RO	0x1	CCP0 Pin Present When set, indicates that Capture/Compare/PWM pin 0 is present. Note: The GPTMPP register does not provide this information.
23	ADC0AIN7	RO	0x1	ADC Module 0 AIN7 Pin Present When set, indicates that ADC module 0 input pin 7 is present. Note: The CH field in the ADCPP register provides this information.
22	ADC0AIN6	RO	0x1	ADC Module 0 AIN6 Pin Present When set, indicates that ADC module 0 input pin 6 is present. Note: The CH field in the ADCPP register provides this information.
21	ADC0AIN5	RO	0x1	ADC Module 0 AIN5 Pin Present When set, indicates that ADC module 0 input pin 5 is present. Note: The CH field in the ADCPP register provides this information.
20	ADC0AIN4	RO	0x1	ADC Module 0 AIN4 Pin Present When set, indicates that ADC module 0 input pin 4 is present. Note: The CH field in the ADCPP register provides this information.
19	ADC0AIN3	RO	0x1	ADC Module 0 AIN3 Pin Present When set, indicates that ADC module 0 input pin 3 is present. Note: The CH field in the ADCPP register provides this information.
18	ADC0AIN2	RO	0x1	ADC Module 0 AIN2 Pin Present When set, indicates that ADC module 0 input pin 2 is present. Note: The CH field in the ADCPP register provides this information.
17	ADC0AIN1	RO	0x1	ADC Module 0 AIN1 Pin Present When set, indicates that ADC module 0 input pin 1 is present. Note: The CH field in the ADCPP register provides this information.
16	ADC0AIN0	RO	0x1	ADC Module 0 AIN0 Pin Present When set, indicates that ADC module 0 input pin 0 is present. Note: The CH field in the ADCPP register provides this information.
15	PWMFAULT	RO	0x1	PWM Fault Pin Present When set, indicates that a PWM Fault pin is present. See DC5 for specific Fault pins on this device. Note: The FCNT field in the PWMPP register provides this information.
14	C2O	RO	0x0	C2o Pin Present When set, indicates that the analog comparator 2 output pin is present. Note: The C2O bit in the ACMPPP register provides this information.

Bit/Field	Name	Type	Reset	Description
13	C2PLUS	RO	0x0	<p>C2+ Pin Present</p> <p>When set, indicates that the analog comparator 2 (+) input pin is present.</p> <p>Note: This pin is present when analog comparator 2 is present.</p>
12	C2MINUS	RO	0x0	<p>C2- Pin Present</p> <p>When set, indicates that the analog comparator 2 (-) input pin is present.</p> <p>Note: This pin is present when analog comparator 2 is present.</p>
11	C1O	RO	0x1	<p>C1o Pin Present</p> <p>When set, indicates that the analog comparator 1 output pin is present.</p> <p>Note: The C1O bit in the ACMPPP register provides this information.</p>
10	C1PLUS	RO	0x1	<p>C1+ Pin Present</p> <p>When set, indicates that the analog comparator 1 (+) input pin is present.</p> <p>Note: This pin is present when analog comparator 1 is present.</p>
9	C1MINUS	RO	0x1	<p>C1- Pin Present</p> <p>When set, indicates that the analog comparator 1 (-) input pin is present.</p> <p>Note: This pin is present when analog comparator 1 is present.</p>
8	C0O	RO	0x1	<p>C0o Pin Present</p> <p>When set, indicates that the analog comparator 0 output pin is present.</p> <p>Note: The C0O bit in the ACMPPP register provides this information.</p>
7	C0PLUS	RO	0x1	<p>C0+ Pin Present</p> <p>When set, indicates that the analog comparator 0 (+) input pin is present.</p> <p>Note: This pin is present when analog comparator 0 is present.</p>
6	C0MINUS	RO	0x1	<p>C0- Pin Present</p> <p>When set, indicates that the analog comparator 0 (-) input pin is present.</p> <p>Note: This pin is present when analog comparator 0 is present.</p>
5	PWM5	RO	0x1	<p>PWM5 Pin Present</p> <p>When set, indicates that the PWM pin 5 is present.</p> <p>Note: The GCNT field in the PWMPP register provides this information.</p>
4	PWM4	RO	0x1	<p>PWM4 Pin Present</p> <p>When set, indicates that the PWM pin 4 is present.</p> <p>Note: The GCNT field in the PWMPP register provides this information.</p>
3	PWM3	RO	0x1	<p>PWM3 Pin Present</p> <p>When set, indicates that the PWM pin 3 is present.</p> <p>Note: The GCNT field in the PWMPP register provides this information.</p>

Bit/Field	Name	Type	Reset	Description
2	PWM2	RO	0x1	<p>PWM2 Pin Present</p> <p>When set, indicates that the PWM pin 2 is present.</p> <p>Note: The GCNT field in the PWMPP register provides this information.</p>
1	PWM1	RO	0x1	<p>PWM1 Pin Present</p> <p>When set, indicates that the PWM pin 1 is present.</p> <p>Note: The GCNT field in the PWMPP register provides this information.</p>
0	PWM0	RO	0x1	<p>PWM0 Pin Present</p> <p>When set, indicates that the PWM pin 0 is present.</p> <p>Note: The GCNT field in the PWMPP register provides this information.</p>

Register 128: Device Capabilities 4 (DC4), offset 0x01C

This register is predefined by the part and can be used to verify features. If any bit is clear in this register, the module is not present. The corresponding bit in the **RCGC2**, **SCGC2**, **DCGC2**, and the peripheral-specific **RCGC**, **SCGC**, and **DCGC** registers registers cannot be set.

Important: This register is provided for legacy software support only.

The Peripheral Present registers should be used to determine which modules are implemented on this microcontroller. A read of **DC4** correctly identifies if a legacy module is present but software must use the Peripheral Present registers to determine if a module is present that is not supported by the **DCn** registers.

The peripheral-resident Peripheral Properties registers should be used to determine which pins and features are available on this microcontroller. A read of **DC4** correctly identifies if a legacy pin or feature is present. Software must use the Peripheral Properties registers to determine if a pin or feature is present that is not supported by the **DCn** registers.

Device Capabilities 4 (DC4)

Base 0x400F.E000
Offset 0x01C
Type RO, reset 0x0004.F07F

	31	30	29	28	27	26	25	24	23	22	21	20	19	18	17	16
	reserved	EPHY0	reserved	EMAC0	reserved			E1588	reserved				PICAL	reserved		
Type	RO	RO	RO	RO	RO	RO	RO	RO	RO	RO	RO	RO	RO	RO	RO	RO
Reset	0	0	0	0	0	0	0	0	0	0	0	0	0	1	0	0
	15	14	13	12	11	10	9	8	7	6	5	4	3	2	1	0
	CCP7	CCP6	UDMA	ROM	reserved			GPIOJ	GPIOH	GPIOG	GPIOF	GPIOE	GIPOD	GPIOC	GPIOB	GPIOA
Type	RO	RO	RO	RO	RO	RO	RO	RO	RO	RO	RO	RO	RO	RO	RO	RO
Reset	1	1	1	1	0	0	0	0	0	0	1	1	1	1	1	1

Bit/Field	Name	Type	Reset	Description
31	reserved	RO	0	Software should not rely on the value of a reserved bit. To provide compatibility with future products, the value of a reserved bit should be preserved across a read-modify-write operation.
30	EPHY0	RO	0x0	Ethernet PHY Layer 0 Present When set, indicates that Ethernet PHY layer 0 is present.
29	reserved	RO	0	Software should not rely on the value of a reserved bit. To provide compatibility with future products, the value of a reserved bit should be preserved across a read-modify-write operation.
28	EMAC0	RO	0x0	Ethernet MAC Layer 0 Present When set, indicates that Ethernet MAC layer 0 is present.
27:25	reserved	RO	0	Software should not rely on the value of a reserved bit. To provide compatibility with future products, the value of a reserved bit should be preserved across a read-modify-write operation.
24	E1588	RO	0x0	1588 Capable When set, indicates that Ethernet MAC layer 0 is 1588 capable.

Bit/Field	Name	Type	Reset	Description
23:19	reserved	RO	0	Software should not rely on the value of a reserved bit. To provide compatibility with future products, the value of a reserved bit should be preserved across a read-modify-write operation.
18	PICAL	RO	0x1	PIOSC Calibrate When set, indicates that the PIOSC can be calibrated by software.
17:16	reserved	RO	0	Software should not rely on the value of a reserved bit. To provide compatibility with future products, the value of a reserved bit should be preserved across a read-modify-write operation.
15	CCP7	RO	0x1	CCP7 Pin Present When set, indicates that Capture/Compare/PWM pin 7 is present. Note: The GPTMPP register does not provide this information.
14	CCP6	RO	0x1	CCP6 Pin Present When set, indicates that Capture/Compare/PWM pin 6 is present. Note: The GPTMPP register does not provide this information.
13	UDMA	RO	0x1	Micro-DMA Module Present When set, indicates that the micro-DMA module present.
12	ROM	RO	0x1	Internal Code ROM Present When set, indicates that internal code ROM is present.
11:9	reserved	RO	0	Software should not rely on the value of a reserved bit. To provide compatibility with future products, the value of a reserved bit should be preserved across a read-modify-write operation.
8	GPIOJ	RO	0x0	GPIO Port J Present When set, indicates that GPIO Port J is present.
7	GPIOH	RO	0x0	GPIO Port H Present When set, indicates that GPIO Port H is present.
6	GPIOG	RO	0x1	GPIO Port G Present When set, indicates that GPIO Port G is present.
5	GPIOF	RO	0x1	GPIO Port F Present When set, indicates that GPIO Port F is present.
4	GPIOE	RO	0x1	GPIO Port E Present When set, indicates that GPIO Port E is present.
3	GIPOD	RO	0x1	GPIO Port D Present When set, indicates that GPIO Port D is present.
2	GPIOC	RO	0x1	GPIO Port C Present When set, indicates that GPIO Port C is present.
1	GPIOB	RO	0x1	GPIO Port B Present When set, indicates that GPIO Port B is present.

Bit/Field	Name	Type	Reset	Description
0	GPIOA	RO	0x1	GPIO Port A Present When set, indicates that GPIO Port A is present.

Register 129: Device Capabilities 5 (DC5), offset 0x020

This register is predefined by the part and can be used to verify PWM features. If any bit is clear in this register, the module is not present.

Important: This register is provided for legacy software support only.

The **PWM Peripheral Properties (PWMPPP)** register should be used to determine what pins and features are available on PWM modules. A read of this register correctly identifies if a legacy pin or feature is present. Software must use the **PWMPPP** register to determine if a pin or feature that is not supported by the **DCn** registers is present.

Device Capabilities 5 (DC5)

Base 0x400F.E000
Offset 0x020
Type RO, reset 0x0730.00FF

	31	30	29	28	27	26	25	24	23	22	21	20	19	18	17	16
	reserved				PWMFAULT3	PWMFAULT2	PWMFAULT1	PWMFAULT0	reserved		PWMEFLT	PWMESYNC	reserved			
Type	RO	RO	RO	RO	RO	RO	RO	RO	RO	RO	RO	RO	RO	RO	RO	RO
Reset	0	0	0	0	0	1	1	1	0	0	1	1	0	0	0	0
	15	14	13	12	11	10	9	8	7	6	5	4	3	2	1	0
	reserved								PWM7	PWM6	PWM5	PWM4	PWM3	PWM2	PWM1	PWM0
Type	RO	RO	RO	RO	RO	RO	RO	RO	RO	RO	RO	RO	RO	RO	RO	RO
Reset	0	0	0	0	0	0	0	0	1	1	1	1	1	1	1	1

Bit/Field	Name	Type	Reset	Description
31:28	reserved	RO	0	Software should not rely on the value of a reserved bit. To provide compatibility with future products, the value of a reserved bit should be preserved across a read-modify-write operation.
27	PWMFAULT3	RO	0x0	PWM Fault 3 Pin Present When set, indicates that the PWM Fault 3 pin is present.
26	PWMFAULT2	RO	0x1	PWM Fault 2 Pin Present When set, indicates that the PWM Fault 2 pin is present.
25	PWMFAULT1	RO	0x1	PWM Fault 1 Pin Present When set, indicates that the PWM Fault 1 pin is present.
24	PWMFAULT0	RO	0x1	PWM Fault 0 Pin Present When set, indicates that the PWM Fault 0 pin is present.
23:22	reserved	RO	0	Software should not rely on the value of a reserved bit. To provide compatibility with future products, the value of a reserved bit should be preserved across a read-modify-write operation.
21	PWMEFLT	RO	0x1	PWM Extended Fault Active When set, indicates that the PWM Extended Fault feature is active.
20	PWMESYNC	RO	0x1	PWM Extended SYNC Active When set, indicates that the PWM Extended SYNC feature is active.
19:8	reserved	RO	0	Software should not rely on the value of a reserved bit. To provide compatibility with future products, the value of a reserved bit should be preserved across a read-modify-write operation.

Bit/Field	Name	Type	Reset	Description
7	PWM7	RO	0x1	PWM7 Pin Present When set, indicates that the PWM pin 7 is present.
6	PWM6	RO	0x1	PWM6 Pin Present When set, indicates that the PWM pin 6 is present.
5	PWM5	RO	0x1	PWM5 Pin Present When set, indicates that the PWM pin 5 is present.
4	PWM4	RO	0x1	PWM4 Pin Present When set, indicates that the PWM pin 4 is present.
3	PWM3	RO	0x1	PWM3 Pin Present When set, indicates that the PWM pin 3 is present.
2	PWM2	RO	0x1	PWM2 Pin Present When set, indicates that the PWM pin 2 is present.
1	PWM1	RO	0x1	PWM1 Pin Present When set, indicates that the PWM pin 1 is present.
0	PWM0	RO	0x1	PWM0 Pin Present When set, indicates that the PWM pin 0 is present.

Register 130: Device Capabilities 6 (DC6), offset 0x024

This register is predefined by the part and can be used to verify features. If any bit is clear in this register, the module is not present. The corresponding bit in the **RCGC0**, **SCGC0**, and **DCGC0** registers cannot be set.

Important: This register is provided for legacy software support only.

The **USB Peripheral Properties (USBPP)** register should be used to determine what features are available on the USB module. A read of this register correctly identifies if a legacy feature is present. Software must use the **USBPP** register to determine if a pin or feature that is not supported by the **DCn** registers is present.

Device Capabilities 6 (DC6)

Base 0x400F.E000

Offset 0x024

Type RO, reset 0x0000.0013

	31	30	29	28	27	26	25	24	23	22	21	20	19	18	17	16
	reserved															
Type	RO	RO	RO	RO	RO	RO	RO	RO	RO	RO	RO	RO	RO	RO	RO	RO
Reset	0	0	0	0	0	0	0	0	0	0	0	0	0	0	0	0
	15	14	13	12	11	10	9	8	7	6	5	4	3	2	1	0
	reserved												USB0PHY	reserved		USB0
Type	RO	RO	RO	RO	RO	RO	RO	RO	RO	RO	RO	RO	RO	RO	RO	RO
Reset	0	0	0	0	0	0	0	0	0	0	0	1	0	0	1	1

Bit/Field	Name	Type	Reset	Description
31:5	reserved	RO	0	Software should not rely on the value of a reserved bit. To provide compatibility with future products, the value of a reserved bit should be preserved across a read-modify-write operation.
4	USB0PHY	RO	0x1	USB Module 0 PHY Present When set, indicates that the USB module 0 PHY is present.
3:2	reserved	RO	0	Software should not rely on the value of a reserved bit. To provide compatibility with future products, the value of a reserved bit should be preserved across a read-modify-write operation.
1:0	USB0	RO	0x3	USB Module 0 Present This field indicates that USB module 0 is present and specifies its capability.
	sysValue	Description		
	0x0	NA		USB0 is not present.
	0x1	DEVICE		USB0 is Device Only.
	0x2	HOST		USB0 is Device or Host.
	0x3	OTG		USB0 is OTG.

Register 131: Device Capabilities 7 (DC7), offset 0x028

This register is predefined by the part and can be used to verify μ DMA channel features. A 1 indicates the channel is available on this device; a 0 that the channel is only available on other devices in the family. Channels can have multiple assignments, see “Channel Assignments” on page 561 for more information.

Important: This register is provided for legacy software support only. The `DMACHANS` bit field in the **DMA Status (DMASTAT)** register indicates the number of DMA channels.

Device Capabilities 7 (DC7)

Base 0x400F.E000

Offset 0x028

Type RO, reset 0xFFFF.FFFF

	31	30	29	28	27	26	25	24	23	22	21	20	19	18	17	16
	reserved	DMACH30	DMACH29	DMACH28	DMACH27	DMACH26	DMACH25	DMACH24	DMACH23	DMACH22	DMACH21	DMACH20	DMACH19	DMACH18	DMACH17	DMACH16
Type	RO	RO	RO	RO	RO	RO	RO	RO	RO	RO	RO	RO	RO	RO	RO	RO
Reset	1	1	1	1	1	1	1	1	1	1	1	1	1	1	1	1
	15	14	13	12	11	10	9	8	7	6	5	4	3	2	1	0
	DMACH15	DMACH14	DMACH13	DMACH12	DMACH11	DMACH10	DMACH9	DMACH8	DMACH7	DMACH6	DMACH5	DMACH4	DMACH3	DMACH2	DMACH1	DMACH0
Type	RO	RO	RO	RO	RO	RO	RO	RO	RO	RO	RO	RO	RO	RO	RO	RO
Reset	1	1	1	1	1	1	1	1	1	1	1	1	1	1	1	1

Bit/Field	Name	Type	Reset	Description
31	reserved	RO	0x1	DMA Channel 31 When set, indicates μ DMA channel 31 is available.
30	DMACH30	RO	0x1	DMA Channel 30 When set, indicates μ DMA channel 30 is available.
29	DMACH29	RO	0x1	DMA Channel 29 When set, indicates μ DMA channel 29 is available.
28	DMACH28	RO	0x1	DMA Channel 28 When set, indicates μ DMA channel 28 is available.
27	DMACH27	RO	0x1	DMA Channel 27 When set, indicates μ DMA channel 27 is available.
26	DMACH26	RO	0x1	DMA Channel 26 When set, indicates μ DMA channel 26 is available.
25	DMACH25	RO	0x1	DMA Channel 25 When set, indicates μ DMA channel 25 is available.
24	DMACH24	RO	0x1	DMA Channel 24 When set, indicates μ DMA channel 24 is available.
23	DMACH23	RO	0x1	DMA Channel 23 When set, indicates μ DMA channel 23 is available.
22	DMACH22	RO	0x1	DMA Channel 22 When set, indicates μ DMA channel 22 is available.

Bit/Field	Name	Type	Reset	Description
21	DMACH21	RO	0x1	DMA Channel 21 When set, indicates μ DMA channel 21 is available.
20	DMACH20	RO	0x1	DMA Channel 20 When set, indicates μ DMA channel 20 is available.
19	DMACH19	RO	0x1	DMA Channel 19 When set, indicates μ DMA channel 19 is available.
18	DMACH18	RO	0x1	DMA Channel 18 When set, indicates μ DMA channel 18 is available.
17	DMACH17	RO	0x1	DMA Channel 17 When set, indicates μ DMA channel 17 is available.
16	DMACH16	RO	0x1	DMA Channel 16 When set, indicates μ DMA channel 16 is available.
15	DMACH15	RO	0x1	DMA Channel 15 When set, indicates μ DMA channel 15 is available.
14	DMACH14	RO	0x1	DMA Channel 14 When set, indicates μ DMA channel 14 is available.
13	DMACH13	RO	0x1	DMA Channel 13 When set, indicates μ DMA channel 13 is available.
12	DMACH12	RO	0x1	DMA Channel 12 When set, indicates μ DMA channel 12 is available.
11	DMACH11	RO	0x1	DMA Channel 11 When set, indicates μ DMA channel 11 is available.
10	DMACH10	RO	0x1	DMA Channel 10 When set, indicates μ DMA channel 10 is available.
9	DMACH9	RO	0x1	DMA Channel 9 When set, indicates μ DMA channel 9 is available.
8	DMACH8	RO	0x1	DMA Channel 8 When set, indicates μ DMA channel 8 is available.
7	DMACH7	RO	0x1	DMA Channel 7 When set, indicates μ DMA channel 7 is available.
6	DMACH6	RO	0x1	DMA Channel 6 When set, indicates μ DMA channel 6 is available.
5	DMACH5	RO	0x1	DMA Channel 5 When set, indicates μ DMA channel 5 is available.
4	DMACH4	RO	0x1	DMA Channel 4 When set, indicates μ DMA channel 4 is available.

Bit/Field	Name	Type	Reset	Description
3	DMACH3	RO	0x1	DMA Channel 3 When set, indicates μ DMA channel 3 is available.
2	DMACH2	RO	0x1	DMA Channel 2 When set, indicates μ DMA channel 2 is available.
1	DMACH1	RO	0x1	DMA Channel 1 When set, indicates μ DMA channel 1 is available.
0	DMACH0	RO	0x1	DMA Channel 0 When set, indicates μ DMA channel 0 is available.

Register 132: Device Capabilities 8 (DC8), offset 0x02C

This register is predefined by the part and can be used to verify features.

Important: This register is provided for legacy software support only.

The **ADC Peripheral Properties (ADCPP)** register should be used to determine how many input channels are available on the ADC module. A read of this register correctly identifies if legacy channels are present but software must use the **ADCPP** register to determine if a channel is present that is not supported by the **DCn** registers.

Device Capabilities 8 (DC8)

Base 0x400F.E000

Offset 0x02C

Type RO, reset 0x0FFF.0FFF

	31	30	29	28	27	26	25	24	23	22	21	20	19	18	17	16
	ADC1AIN15	ADC1AIN14	ADC1AIN13	ADC1AIN12	ADC1AIN11	ADC1AIN10	ADC1AIN9	ADC1AIN8	ADC1AIN7	ADC1AIN6	ADC1AIN5	ADC1AIN4	ADC1AIN3	ADC1AIN2	ADC1AIN1	ADC1AIN0
Type	RO	RO	RO	RO	RO	RO	RO	RO	RO	RO	RO	RO	RO	RO	RO	RO
Reset	0	0	0	0	1	1	1	1	1	1	1	1	1	1	1	1

	15	14	13	12	11	10	9	8	7	6	5	4	3	2	1	0
	ADC0AIN15	ADC0AIN14	ADC0AIN13	ADC0AIN12	ADC0AIN11	ADC0AIN10	ADC0AIN9	ADC0AIN8	ADC0AIN7	ADC0AIN6	ADC0AIN5	ADC0AIN4	ADC0AIN3	ADC0AIN2	ADC0AIN1	ADC0AIN0
Type	RO	RO	RO	RO	RO	RO	RO	RO	RO	RO	RO	RO	RO	RO	RO	RO
Reset	0	0	0	0	1	1	1	1	1	1	1	1	1	1	1	1

Bit/Field	Name	Type	Reset	Description
31	ADC1AIN15	RO	0x0	ADC Module 1 AIN15 Pin Present When set, indicates that ADC module 1 input pin 15 is present.
30	ADC1AIN14	RO	0x0	ADC Module 1 AIN14 Pin Present When set, indicates that ADC module 1 input pin 14 is present.
29	ADC1AIN13	RO	0x0	ADC Module 1 AIN13 Pin Present When set, indicates that ADC module 1 input pin 13 is present.
28	ADC1AIN12	RO	0x0	ADC Module 1 AIN12 Pin Present When set, indicates that ADC module 1 input pin 12 is present.
27	ADC1AIN11	RO	0x1	ADC Module 1 AIN11 Pin Present When set, indicates that ADC module 1 input pin 11 is present.
26	ADC1AIN10	RO	0x1	ADC Module 1 AIN10 Pin Present When set, indicates that ADC module 1 input pin 10 is present.
25	ADC1AIN9	RO	0x1	ADC Module 1 AIN9 Pin Present When set, indicates that ADC module 1 input pin 9 is present.
24	ADC1AIN8	RO	0x1	ADC Module 1 AIN8 Pin Present When set, indicates that ADC module 1 input pin 8 is present.
23	ADC1AIN7	RO	0x1	ADC Module 1 AIN7 Pin Present When set, indicates that ADC module 1 input pin 7 is present.
22	ADC1AIN6	RO	0x1	ADC Module 1 AIN6 Pin Present When set, indicates that ADC module 1 input pin 6 is present.

Bit/Field	Name	Type	Reset	Description
21	ADC1AIN5	RO	0x1	ADC Module 1 AIN5 Pin Present When set, indicates that ADC module 1 input pin 5 is present.
20	ADC1AIN4	RO	0x1	ADC Module 1 AIN4 Pin Present When set, indicates that ADC module 1 input pin 4 is present.
19	ADC1AIN3	RO	0x1	ADC Module 1 AIN3 Pin Present When set, indicates that ADC module 1 input pin 3 is present.
18	ADC1AIN2	RO	0x1	ADC Module 1 AIN2 Pin Present When set, indicates that ADC module 1 input pin 2 is present.
17	ADC1AIN1	RO	0x1	ADC Module 1 AIN1 Pin Present When set, indicates that ADC module 1 input pin 1 is present.
16	ADC1AIN0	RO	0x1	ADC Module 1 AIN0 Pin Present When set, indicates that ADC module 1 input pin 0 is present.
15	ADC0AIN15	RO	0x0	ADC Module 0 AIN15 Pin Present When set, indicates that ADC module 0 input pin 15 is present.
14	ADC0AIN14	RO	0x0	ADC Module 0 AIN14 Pin Present When set, indicates that ADC module 0 input pin 14 is present.
13	ADC0AIN13	RO	0x0	ADC Module 0 AIN13 Pin Present When set, indicates that ADC module 0 input pin 13 is present.
12	ADC0AIN12	RO	0x0	ADC Module 0 AIN12 Pin Present When set, indicates that ADC module 0 input pin 12 is present.
11	ADC0AIN11	RO	0x1	ADC Module 0 AIN11 Pin Present When set, indicates that ADC module 0 input pin 11 is present.
10	ADC0AIN10	RO	0x1	ADC Module 0 AIN10 Pin Present When set, indicates that ADC module 0 input pin 10 is present.
9	ADC0AIN9	RO	0x1	ADC Module 0 AIN9 Pin Present When set, indicates that ADC module 0 input pin 9 is present.
8	ADC0AIN8	RO	0x1	ADC Module 0 AIN8 Pin Present When set, indicates that ADC module 0 input pin 8 is present.
7	ADC0AIN7	RO	0x1	ADC Module 0 AIN7 Pin Present When set, indicates that ADC module 0 input pin 7 is present.
6	ADC0AIN6	RO	0x1	ADC Module 0 AIN6 Pin Present When set, indicates that ADC module 0 input pin 6 is present.
5	ADC0AIN5	RO	0x1	ADC Module 0 AIN5 Pin Present When set, indicates that ADC module 0 input pin 5 is present.
4	ADC0AIN4	RO	0x1	ADC Module 0 AIN4 Pin Present When set, indicates that ADC module 0 input pin 4 is present.

Bit/Field	Name	Type	Reset	Description
3	ADC0AIN3	RO	0x1	ADC Module 0 AIN3 Pin Present When set, indicates that ADC module 0 input pin 3 is present.
2	ADC0AIN2	RO	0x1	ADC Module 0 AIN2 Pin Present When set, indicates that ADC module 0 input pin 2 is present.
1	ADC0AIN1	RO	0x1	ADC Module 0 AIN1 Pin Present When set, indicates that ADC module 0 input pin 1 is present.
0	ADC0AIN0	RO	0x1	ADC Module 0 AIN0 Pin Present When set, indicates that ADC module 0 input pin 0 is present.

Register 133: Software Reset Control 0 (SRCR0), offset 0x040

This register allows individual modules to be reset. Writes to this register are masked by the bits in the **Device Capabilities 1 (DC1)** register.

Important: This register is provided for legacy software support only.

The peripheral-specific Software Reset registers (such as **SRWD**) should be used to reset specific peripherals. A write to this legacy register also writes the corresponding bit in the peripheral-specific register. Any bits that are changed by writing to this legacy register can be read back correctly with a read of this register. Software must use the peripheral-specific registers to support modules that are not present in the legacy registers. If software uses a peripheral-specific register to write a legacy peripheral (such as Watchdog 1), the write causes proper operation, but the value of that bit is not reflected in this register. If software uses both legacy and peripheral-specific register accesses, the peripheral-specific registers must be accessed by read-modify-write operations that affect only peripherals that are not present in the legacy registers. In this manner, both the peripheral-specific and legacy registers have coherent information.

Software Reset Control 0 (SRCR0)

Base 0x400F.E000

Offset 0x040

Type RO, reset 0x0000.0000

	31	30	29	28	27	26	25	24	23	22	21	20	19	18	17	16
	reserved			WDT1	reserved		CAN1	CAN0	reserved			PWM0	reserved		ADC1	ADC0
Type	RO	RO	RO	RO	RO	RO	RO	RO	RO	RO	RO	RO	RO	RO	RO	RO
Reset	0	0	0	0	0	0	0	0	0	0	0	0	0	0	0	0
	15	14	13	12	11	10	9	8	7	6	5	4	3	2	1	0
	reserved												WDT0	reserved		
Type	RO	RO	RO	RO	RO	RO	RO	RO	RO	RO	RO	RO	RO	RO	RO	RO
Reset	0	0	0	0	0	0	0	0	0	0	0	0	0	0	0	0

Bit/Field	Name	Type	Reset	Description
31:29	reserved	RO	0	Software should not rely on the value of a reserved bit. To provide compatibility with future products, the value of a reserved bit should be preserved across a read-modify-write operation.
28	WDT1	RO	0x0	WDT1 Reset Control When this bit is set, Watchdog Timer module 1 is reset. All internal data is lost and the registers are returned to their reset states. This bit must be manually cleared after being set.
27:26	reserved	RO	0	Software should not rely on the value of a reserved bit. To provide compatibility with future products, the value of a reserved bit should be preserved across a read-modify-write operation.
25	CAN1	RO	0x0	CAN1 Reset Control When this bit is set, CAN module 1 is reset. All internal data is lost and the registers are returned to their reset states. This bit must be manually cleared after being set.
24	CAN0	RO	0x0	CAN0 Reset Control When this bit is set, CAN module 0 is reset. All internal data is lost and the registers are returned to their reset states. This bit must be manually cleared after being set.

Bit/Field	Name	Type	Reset	Description
23:21	reserved	RO	0	Software should not rely on the value of a reserved bit. To provide compatibility with future products, the value of a reserved bit should be preserved across a read-modify-write operation.
20	PWM0	RO	0x0	PWM Reset Control When this bit is set, PWM module 0 is reset. All internal data is lost and the registers are returned to their reset states. This bit must be manually cleared after being set.
19:18	reserved	RO	0	Software should not rely on the value of a reserved bit. To provide compatibility with future products, the value of a reserved bit should be preserved across a read-modify-write operation.
17	ADC1	RO	0x0	ADC1 Reset Control When this bit is set, ADC module 1 is reset. All internal data is lost and the registers are returned to their reset states. This bit must be manually cleared after being set.
16	ADC0	RO	0x0	ADC0 Reset Control When this bit is set, ADC module 0 is reset. All internal data is lost and the registers are returned to their reset states. This bit must be manually cleared after being set.
15:4	reserved	RO	0	Software should not rely on the value of a reserved bit. To provide compatibility with future products, the value of a reserved bit should be preserved across a read-modify-write operation.
3	WDT0	RO	0x0	WDT0 Reset Control When this bit is set, Watchdog Timer module 0 is reset. All internal data is lost and the registers are returned to their reset states. This bit must be manually cleared after being set.
2:0	reserved	RO	0	Software should not rely on the value of a reserved bit. To provide compatibility with future products, the value of a reserved bit should be preserved across a read-modify-write operation.

Register 134: Software Reset Control 1 (SRCR1), offset 0x044

This register allows individual modules to be reset. Writes to this register are masked by the bits in the **Device Capabilities 2 (DC2)** register.

Important: This register is provided for legacy software support only.

The peripheral-specific Software Reset registers (such as **SRTIMER**) should be used to reset specific peripherals. A write to this register also writes the corresponding bit in the peripheral-specific register. Any bits that are changed by writing to this register can be read back correctly with a read of this register. Software must use the peripheral-specific registers to support modules that are not present in the legacy registers. If software uses a peripheral-specific register to write a legacy peripheral (such as **TIMER0**), the write causes proper operation, but the value of that bit is not reflected in this register. If software uses both legacy and peripheral-specific register accesses, the peripheral-specific registers must be accessed by read-modify-write operations that affect only peripherals that are not present in the legacy registers. In this manner, both the peripheral-specific and legacy registers have coherent information.

Note that the **Software Reset Analog Comparator (SRACMP)** register has only one bit to set the analog comparator module. Resetting the module resets all the blocks. If any of the **COMP_n** bits are set, the entire analog comparator module is reset. It is not possible to reset the blocks individually.

Software Reset Control 1 (SRCR1)

Base 0x400F.E000
 Offset 0x044
 Type RO, reset 0x0000.0000

	31	30	29	28	27	26	25	24	23	22	21	20	19	18	17	16
	reserved						COMP1	COMP0	reserved				TIMER3	TIMER2	TIMER1	TIMER0
Type	RO	RO	RO	RO	RO	RO	RO	RO	RO	RO	RO	RO	RO	RO	RO	RO
Reset	0	0	0	0	0	0	0	0	0	0	0	0	0	0	0	0
	15	14	13	12	11	10	9	8	7	6	5	4	3	2	1	0
	reserved	I2C1	reserved	I2C0	reserved		QEI1	QEI0	reserved		SSI1	SSI0	reserved	UART2	UART1	UART0
Type	RO	RO	RO	RO	RO	RO	RO	RO	RO	RO	RO	RO	RO	RO	RO	RO
Reset	0	0	0	0	0	0	0	0	0	0	0	0	0	0	0	0

Bit/Field	Name	Type	Reset	Description
31:26	reserved	RO	0	Software should not rely on the value of a reserved bit. To provide compatibility with future products, the value of a reserved bit should be preserved across a read-modify-write operation.
25	COMP1	RO	0x0	Analog Comp 1 Reset Control When this bit is set, Analog Comparator module 1 is reset. All internal data is lost and the registers are returned to their reset states. This bit must be manually cleared after being set.
24	COMP0	RO	0x0	Analog Comp 0 Reset Control When this bit is set, Analog Comparator module 0 is reset. All internal data is lost and the registers are returned to their reset states. This bit must be manually cleared after being set.
23:20	reserved	RO	0	Software should not rely on the value of a reserved bit. To provide compatibility with future products, the value of a reserved bit should be preserved across a read-modify-write operation.

Bit/Field	Name	Type	Reset	Description
19	TIMER3	RO	0x0	<p>Timer 3 Reset Control</p> <p>Timer 3 Reset Control. When this bit is set, General-Purpose Timer module 3 is reset. All internal data is lost and the registers are returned to their reset states. This bit must be manually cleared after being set.</p>
18	TIMER2	RO	0x0	<p>Timer 2 Reset Control</p> <p>When this bit is set, General-Purpose Timer module 2 is reset. All internal data is lost and the registers are returned to their reset states. This bit must be manually cleared after being set.</p>
17	TIMER1	RO	0x0	<p>Timer 1 Reset Control</p> <p>When this bit is set, General-Purpose Timer module 1 is reset. All internal data is lost and the registers are returned to their reset states. This bit must be manually cleared after being set.</p>
16	TIMER0	RO	0x0	<p>Timer 0 Reset Control</p> <p>When this bit is set, General-Purpose Timer module 0 is reset. All internal data is lost and the registers are returned to their reset states. This bit must be manually cleared after being set.</p>
15	reserved	RO	0	Software should not rely on the value of a reserved bit. To provide compatibility with future products, the value of a reserved bit should be preserved across a read-modify-write operation.
14	I2C1	RO	0x0	<p>I2C1 Reset Control</p> <p>When this bit is set, I2C module 1 is reset. All internal data is lost and the registers are returned to their reset states. This bit must be manually cleared after being set.</p>
13	reserved	RO	0	Software should not rely on the value of a reserved bit. To provide compatibility with future products, the value of a reserved bit should be preserved across a read-modify-write operation.
12	I2C0	RO	0x0	<p>I2C0 Reset Control</p> <p>When this bit is set, I2C module 0 is reset. All internal data is lost and the registers are returned to their reset states. This bit must be manually cleared after being set.</p>
11:10	reserved	RO	0	Software should not rely on the value of a reserved bit. To provide compatibility with future products, the value of a reserved bit should be preserved across a read-modify-write operation.
9	QEI1	RO	0x0	<p>QEI1 Reset Control</p> <p>When this bit is set, QEI module 1 is reset. All internal data is lost and the registers are returned to their reset states. This bit must be manually cleared after being set.</p>
8	QEI0	RO	0x0	<p>QEI0 Reset Control</p> <p>When this bit is set, QEI module 0 is reset. All internal data is lost and the registers are returned to their reset states. This bit must be manually cleared after being set.</p>
7:6	reserved	RO	0	Software should not rely on the value of a reserved bit. To provide compatibility with future products, the value of a reserved bit should be preserved across a read-modify-write operation.

Bit/Field	Name	Type	Reset	Description
5	SSI1	RO	0x0	SSI1 Reset Control When this bit is set, SSI module 1 is reset. All internal data is lost and the registers are returned to their reset states. This bit must be manually cleared after being set.
4	SSI0	RO	0x0	SSI0 Reset Control When this bit is set, SSI module 0 is reset. All internal data is lost and the registers are returned to their reset states. This bit must be manually cleared after being set.
3	reserved	RO	0	Software should not rely on the value of a reserved bit. To provide compatibility with future products, the value of a reserved bit should be preserved across a read-modify-write operation.
2	UART2	RO	0x0	UART2 Reset Control When this bit is set, UART module 2 is reset. All internal data is lost and the registers are returned to their reset states. This bit must be manually cleared after being set.
1	UART1	RO	0x0	UART1 Reset Control When this bit is set, UART module 1 is reset. All internal data is lost and the registers are returned to their reset states. This bit must be manually cleared after being set.
0	UART0	RO	0x0	UART0 Reset Control When this bit is set, UART module 0 is reset. All internal data is lost and the registers are returned to their reset states. This bit must be manually cleared after being set.

Register 135: Software Reset Control 2 (SRCR2), offset 0x048

This register allows individual modules to be reset. Writes to this register are masked by the bits in the **Device Capabilities 4 (DC4)** register.

Important: This register is provided for legacy software support only.

The peripheral-specific Software Reset registers (such as **SRDMA**) should be used to reset specific peripherals. A write to this legacy register also writes the corresponding bit in the peripheral-specific register. Any bits that are changed by writing to this register can be read back correctly with a read of this register. Software must use the peripheral-specific registers to support modules that are not present in the legacy registers. If software uses a peripheral-specific register to write a legacy peripheral (such as the μ DMA), the write causes proper operation, but the value of that bit is not reflected in this register. If software uses both legacy and peripheral-specific register accesses, the peripheral-specific registers must be accessed by read-modify-write operations that affect only peripherals that are not present in the legacy registers. In this manner, both the peripheral-specific and legacy registers have coherent information.

Software Reset Control 2 (SRCR2)

Base 0x400F.E000
Offset 0x048
Type RO, reset 0x0000.0000

	31	30	29	28	27	26	25	24	23	22	21	20	19	18	17	16
	reserved															USB0
Type	RO	RO	RO	RO	RO	RO	RO	RO	RO	RO	RO	RO	RO	RO	RO	RO
Reset	0	0	0	0	0	0	0	0	0	0	0	0	0	0	0	0
	15	14	13	12	11	10	9	8	7	6	5	4	3	2	1	0
	reserved		UDMA	reserved						GPIOG	GPIOF	GPIOE	GPIOD	GPIOC	GPIOB	GPIOA
Type	RO	RO	RO	RO	RO	RO	RO	RO	RO	RO	RO	RO	RO	RO	RO	RO
Reset	0	0	0	0	0	0	0	0	0	0	0	0	0	0	0	0

Bit/Field	Name	Type	Reset	Description
31:17	reserved	RO	0	Software should not rely on the value of a reserved bit. To provide compatibility with future products, the value of a reserved bit should be preserved across a read-modify-write operation.
16	USB0	RO	0x0	USB0 Reset Control When this bit is set, USB module 0 is reset. All internal data is lost and the registers are returned to their reset states. This bit must be manually cleared after being set.
15:14	reserved	RO	0	Software should not rely on the value of a reserved bit. To provide compatibility with future products, the value of a reserved bit should be preserved across a read-modify-write operation.
13	UDMA	RO	0x0	Micro-DMA Reset Control When this bit is set, μ DMA module is reset. All internal data is lost and the registers are returned to their reset states. This bit must be manually cleared after being set.
12:7	reserved	RO	0	Software should not rely on the value of a reserved bit. To provide compatibility with future products, the value of a reserved bit should be preserved across a read-modify-write operation.

Bit/Field	Name	Type	Reset	Description
6	GPIOG	RO	0x0	Port G Reset Control When this bit is set, Port G module is reset. All internal data is lost and the registers are returned to their reset states. This bit must be manually cleared after being set.
5	GPIOF	RO	0x0	Port F Reset Control When this bit is set, Port F module is reset. All internal data is lost and the registers are returned to their reset states. This bit must be manually cleared after being set.
4	GPIOE	RO	0x0	Port E Reset Control When this bit is set, Port E module is reset. All internal data is lost and the registers are returned to their reset states. This bit must be manually cleared after being set.
3	GPIOD	RO	0x0	Port D Reset Control When this bit is set, Port D module is reset. All internal data is lost and the registers are returned to their reset states. This bit must be manually cleared after being set.
2	GPIOC	RO	0x0	Port C Reset Control When this bit is set, Port C module is reset. All internal data is lost and the registers are returned to their reset states. This bit must be manually cleared after being set.
1	GPIOB	RO	0x0	Port B Reset Control When this bit is set, Port B module is reset. All internal data is lost and the registers are returned to their reset states. This bit must be manually cleared after being set.
0	GPIOA	RO	0x0	Port A Reset Control When this bit is set, Port A module is reset. All internal data is lost and the registers are returned to their reset states. This bit must be manually cleared after being set.

Register 136: Run Mode Clock Gating Control Register 0 (RCGC0), offset 0x100

This register controls the clock gating logic in normal Run mode. Each bit controls a clock enable for a given interface, function, or module. If set, the module receives a clock and functions. Otherwise, the module is unclocked and disabled (saving power). If the module is unclocked, reads or writes to the module generate a bus fault. The reset state of these bits is 0 (unclocked) unless otherwise noted, so that all functional modules are disabled. It is the responsibility of software to enable the ports necessary for the application. Note that these registers may contain more bits than there are interfaces, functions, or modules to control. This configuration is implemented to assure reasonable code compatibility with other family and future parts. **RCGC0** is the clock configuration register for running operation, **SCGC0** for Sleep operation, and **DCGC0** for Deep-Sleep operation. Setting the **ACG** bit in the **Run-Mode Clock Configuration (RCC)** register specifies that the system uses sleep modes. Note that there must be a delay of 3 system clocks after a module clock is enabled before any registers in that module are accessed.

Important: This register is provided for legacy software support only.

The peripheral-specific Run Mode Clock Gating Control registers (such as **RCGCWD**) should be used to reset specific peripherals. A write to this legacy register also writes the corresponding bit in the peripheral-specific register. Any bits that are changed by writing to this register can be read back correctly with a read of this register. Software must use the peripheral-specific registers to support modules that are not present in the legacy registers. If software uses a peripheral-specific register to write a legacy peripheral (such as Watchdog 1), the write causes proper operation, but the value of that bit is not reflected in this register. If software uses both legacy and peripheral-specific register accesses, the peripheral-specific registers must be accessed by read-modify-write operations that affect only peripherals that are not present in the legacy registers. In this manner, both the peripheral-specific and legacy registers have coherent information.

Likewise, the **ADC Peripheral Configuration (ADCPC)** register should be used to configure the ADC sample rate. However, to support legacy software, the **MAXADCnSPD** fields are available. A write to these legacy fields also writes the corresponding field in the peripheral-specific register. If a field is changed by writing to this register, it can be read back correctly with a read of this register. Software must use the peripheral-specific registers to support rates that are not available in this register. If software uses a peripheral-specific register to set the ADC rate, the write causes proper operation, but the value of that field is not reflected in this register. If software uses both legacy and peripheral-specific register accesses, the peripheral-specific registers must be accessed by read-modify-write operations that affect only peripherals that are not present in the legacy registers. In this manner, both the peripheral-specific and legacy registers have coherent information.

Run Mode Clock Gating Control Register 0 (RCGC0)

Base 0x400F.E000
 Offset 0x100
 Type RO, reset 0x0000.0040

	31	30	29	28	27	26	25	24	23	22	21	20	19	18	17	16
	reserved			WDT1	reserved		CAN1	CAN0	reserved			PWM0	reserved		ADC1	ADC0
Type	RO	RO	RO	RO	RO	RO	RO	RO	RO	RO	RO	RO	RO	RO	RO	RO
Reset	0	0	0	0	0	0	0	0	0	0	0	0	0	0	0	0
	15	14	13	12	11	10	9	8	7	6	5	4	3	2	1	0
	reserved				MAXADC1SPD		MAXADC0SPD		reserved	reserved	reserved		WDT0	reserved		
Type	RO	RO	RO	RO	RO	RO	RO	RO	RO	RO	RO	RO	RO	RO	RO	RO
Reset	0	0	0	0	0	0	0	0	0	1	0	0	0	0	0	0

Bit/Field	Name	Type	Reset	Description
31:29	reserved	RO	0	Software should not rely on the value of a reserved bit. To provide compatibility with future products, the value of a reserved bit should be preserved across a read-modify-write operation.
28	WDT1	RO	0x0	WDT1 Clock Gating Control This bit controls the clock gating for the Watchdog Timer module 1. If set, the module receives a clock and functions. Otherwise, the module is unlocked and disabled. If the module is unlocked, a read or write to the module generates a bus fault.
27:26	reserved	RO	0	Software should not rely on the value of a reserved bit. To provide compatibility with future products, the value of a reserved bit should be preserved across a read-modify-write operation.
25	CAN1	RO	0x0	CAN1 Clock Gating Control This bit controls the clock gating for CAN module 1. If set, the module receives a clock and functions. Otherwise, the module is unlocked and disabled. If the module is unlocked, a read or write to the module generates a bus fault.
24	CAN0	RO	0x0	CAN0 Clock Gating Control This bit controls the clock gating for CAN module 0. If set, the module receives a clock and functions. Otherwise, the module is unlocked and disabled. If the module is unlocked, a read or write to the module generates a bus fault.
23:21	reserved	RO	0	Software should not rely on the value of a reserved bit. To provide compatibility with future products, the value of a reserved bit should be preserved across a read-modify-write operation.
20	PWM0	RO	0x0	PWM Clock Gating Control This bit controls the clock gating for the PWM module. If set, the module receives a clock and functions. Otherwise, the module is unlocked and disabled. If the module is unlocked, a read or write to the module generates a bus fault.
19:18	reserved	RO	0	Software should not rely on the value of a reserved bit. To provide compatibility with future products, the value of a reserved bit should be preserved across a read-modify-write operation.

Bit/Field	Name	Type	Reset	Description										
17	ADC1	RO	0x0	<p>ADC1 Clock Gating Control</p> <p>This bit controls the clock gating for SAR ADC module 1. If set, the module receives a clock and functions. Otherwise, the module is unlocked and disabled. If the module is unlocked, a read or write to the module generates a bus fault.</p>										
16	ADC0	RO	0x0	<p>ADC0 Clock Gating Control</p> <p>This bit controls the clock gating for ADC module 0. If set, the module receives a clock and functions. Otherwise, the module is unlocked and disabled. If the module is unlocked, a read or write to the module generates a bus fault.</p>										
15:12	reserved	RO	0	Software should not rely on the value of a reserved bit. To provide compatibility with future products, the value of a reserved bit should be preserved across a read-modify-write operation.										
11:10	MAXADC1SPD	RO	0x0	<p>ADC1 Sample Speed</p> <p>This field sets the rate at which ADC module 1 samples data. You cannot set the rate higher than the maximum rate. You can set the sample rate by setting the MAXADC1SPD bit as follows (all other encodings are reserved):</p> <table border="1"> <thead> <tr> <th>Value</th> <th>Description</th> </tr> </thead> <tbody> <tr> <td>0x3</td> <td>1M samples/second</td> </tr> <tr> <td>0x2</td> <td>500K samples/second</td> </tr> <tr> <td>0x1</td> <td>250K samples/second</td> </tr> <tr> <td>0x0</td> <td>125K samples/second</td> </tr> </tbody> </table>	Value	Description	0x3	1M samples/second	0x2	500K samples/second	0x1	250K samples/second	0x0	125K samples/second
Value	Description													
0x3	1M samples/second													
0x2	500K samples/second													
0x1	250K samples/second													
0x0	125K samples/second													
9:8	MAXADC0SPD	RO	0x0	<p>ADC0 Sample Speed</p> <p>This field sets the rate at which ADC0 samples data. You cannot set the rate higher than the maximum rate. You can set the sample rate by setting the MAXADC0SPD bit as follows (all other encodings are reserved):</p> <table border="1"> <thead> <tr> <th>Value</th> <th>Description</th> </tr> </thead> <tbody> <tr> <td>0x3</td> <td>1M samples/second</td> </tr> <tr> <td>0x2</td> <td>500K samples/second</td> </tr> <tr> <td>0x1</td> <td>250K samples/second</td> </tr> <tr> <td>0x0</td> <td>125K samples/second</td> </tr> </tbody> </table>	Value	Description	0x3	1M samples/second	0x2	500K samples/second	0x1	250K samples/second	0x0	125K samples/second
Value	Description													
0x3	1M samples/second													
0x2	500K samples/second													
0x1	250K samples/second													
0x0	125K samples/second													
7	reserved	RO	0	Software should not rely on the value of a reserved bit. To provide compatibility with future products, the value of a reserved bit should be preserved across a read-modify-write operation.										
6	reserved	RO	1	Software should not rely on the value of a reserved bit. To provide compatibility with future products, the value of a reserved bit should be preserved across a read-modify-write operation.										
5:4	reserved	RO	0	Software should not rely on the value of a reserved bit. To provide compatibility with future products, the value of a reserved bit should be preserved across a read-modify-write operation.										

Bit/Field	Name	Type	Reset	Description
3	WDT0	RO	0x0	WDT0 Clock Gating Control This bit controls the clock gating for the Watchdog Timer module 0. If set, the module receives a clock and functions. Otherwise, the module is unlocked and disabled. If the module is unlocked, a read or write to the module generates a bus fault.
2:0	reserved	RO	0	Software should not rely on the value of a reserved bit. To provide compatibility with future products, the value of a reserved bit should be preserved across a read-modify-write operation.

Register 137: Run Mode Clock Gating Control Register 1 (RCGC1), offset 0x104

This register controls the clock gating logic in normal Run mode. Each bit controls a clock enable for a given interface, function, or module. If set, the module receives a clock and functions. Otherwise, the module is unclocked and disabled (saving power). If the module is unclocked, reads or writes to the module generate a bus fault. The reset state of these bits is 0 (unclocked) unless otherwise noted, so that all functional modules are disabled. It is the responsibility of software to enable the ports necessary for the application. Note that these registers may contain more bits than there are interfaces, functions, or modules to control. This configuration is implemented to assure reasonable code compatibility with other family and future parts. **RCGC1** is the clock configuration register for running operation, **SCGC1** for Sleep operation, and **DCGC1** for Deep-Sleep operation. Setting the **ACG** bit in the **Run-Mode Clock Configuration (RCC)** register specifies that the system uses sleep modes. Note that there must be a delay of 3 system clocks after a module clock is enabled before any registers in that module are accessed.

Important: This register is provided for legacy software support only.

The peripheral-specific Run Mode Clock Gating Control registers (such as **RCGCTIMER**) should be used to reset specific peripherals. A write to this legacy register also writes the corresponding bit in the peripheral-specific register. Any bits that are changed by writing to this register can be read back correctly with a read of this register. Software must use the peripheral-specific registers to support modules that are not present in the legacy registers. If software uses a peripheral-specific register to write a legacy peripheral (such as Timer 0), the write causes proper operation, but the value of that bit is not reflected in this register. If software uses both legacy and peripheral-specific register accesses, the peripheral-specific registers must be accessed by read-modify-write operations that affect only peripherals that are not present in the legacy registers. In this manner, both the peripheral-specific and legacy registers have coherent information.

Run Mode Clock Gating Control Register 1 (RCGC1)

Base 0x400F.E000

Offset 0x104

Type RO, reset 0x0000.0000

	31	30	29	28	27	26	25	24	23	22	21	20	19	18	17	16	
	reserved						COMP1	COMP0	reserved				TIMER3	TIMER2	TIMER1	TIMER0	
Type	RO	RO	RO	RO	RO	RO	RO	RO	RO	RO	RO	RO	RO	RO	RO	RO	
Reset	0	0	0	0	0	0	0	0	0	0	0	0	0	0	0	0	
	15	14	13	12	11	10	9	8	7	6	5	4	3	2	1	0	
	reserved	I2C1	reserved	I2C0	reserved		QE1	QE0	reserved			SSI1	SSI0	reserved	UART2	UART1	UART0
Type	RO	RO	RO	RO	RO	RO	RO	RO	RO	RO	RO	RO	RO	RO	RO	RO	
Reset	0	0	0	0	0	0	0	0	0	0	0	0	0	0	0	0	

Bit/Field	Name	Type	Reset	Description
31:26	reserved	RO	0	Software should not rely on the value of a reserved bit. To provide compatibility with future products, the value of a reserved bit should be preserved across a read-modify-write operation.

Bit/Field	Name	Type	Reset	Description
25	COMP1	RO	0x0	<p>Analog Comparator 1 Clock Gating</p> <p>This bit controls the clock gating for analog comparator 1. If set, the module receives a clock and functions. Otherwise, the module is unlocked and disabled. If the module is unlocked, a read or write to the module generates a bus fault.</p>
24	COMP0	RO	0x0	<p>Analog Comparator 0 Clock Gating</p> <p>This bit controls the clock gating for analog comparator 0. If set, the module receives a clock and functions. Otherwise, the module is unlocked and disabled. If the module is unlocked, a read or write to the module generates a bus fault.</p>
23:20	reserved	RO	0	<p>Software should not rely on the value of a reserved bit. To provide compatibility with future products, the value of a reserved bit should be preserved across a read-modify-write operation.</p>
19	TIMER3	RO	0x0	<p>Timer 3 Clock Gating Control</p> <p>This bit controls the clock gating for General-Purpose Timer module 3. If set, the module receives a clock and functions. Otherwise, the module is unlocked and disabled. If the module is unlocked, a read or write to the module generates a bus fault.</p>
18	TIMER2	RO	0x0	<p>Timer 2 Clock Gating Control</p> <p>This bit controls the clock gating for General-Purpose Timer module 2. If set, the module receives a clock and functions. Otherwise, the module is unlocked and disabled. If the module is unlocked, a read or write to the module generates a bus fault.</p>
17	TIMER1	RO	0x0	<p>Timer 1 Clock Gating Control</p> <p>This bit controls the clock gating for General-Purpose Timer module 1. If set, the module receives a clock and functions. Otherwise, the module is unlocked and disabled. If the module is unlocked, a read or write to the module generates a bus fault.</p>
16	TIMER0	RO	0x0	<p>Timer 0 Clock Gating Control</p> <p>This bit controls the clock gating for General-Purpose Timer module 0. If set, the module receives a clock and functions. Otherwise, the module is unlocked and disabled. If the module is unlocked, a read or write to the module generates a bus fault.</p>
15	reserved	RO	0	<p>Software should not rely on the value of a reserved bit. To provide compatibility with future products, the value of a reserved bit should be preserved across a read-modify-write operation.</p>
14	I2C1	RO	0x0	<p>I2C1 Clock Gating Control</p> <p>This bit controls the clock gating for I2C module 1. If set, the module receives a clock and functions. Otherwise, the module is unlocked and disabled. If the module is unlocked, a read or write to the module generates a bus fault.</p>
13	reserved	RO	0	<p>Software should not rely on the value of a reserved bit. To provide compatibility with future products, the value of a reserved bit should be preserved across a read-modify-write operation.</p>

Bit/Field	Name	Type	Reset	Description
12	I2C0	RO	0x0	<p>I2C0 Clock Gating Control</p> <p>This bit controls the clock gating for I2C module 0. If set, the module receives a clock and functions. Otherwise, the module is unlocked and disabled. If the module is unlocked, a read or write to the module generates a bus fault.</p>
11:10	reserved	RO	0	Software should not rely on the value of a reserved bit. To provide compatibility with future products, the value of a reserved bit should be preserved across a read-modify-write operation.
9	QE11	RO	0x0	<p>QE11 Clock Gating Control</p> <p>This bit controls the clock gating for QE1 module 1. If set, the module receives a clock and functions. Otherwise, the module is unlocked and disabled. If the module is unlocked, a read or write to the module generates a bus fault.</p>
8	QE10	RO	0x0	<p>QE10 Clock Gating Control</p> <p>This bit controls the clock gating for QE1 module 0. If set, the module receives a clock and functions. Otherwise, the module is unlocked and disabled. If the module is unlocked, a read or write to the module generates a bus fault.</p>
7:6	reserved	RO	0	Software should not rely on the value of a reserved bit. To provide compatibility with future products, the value of a reserved bit should be preserved across a read-modify-write operation.
5	SSI1	RO	0x0	<p>SSI1 Clock Gating Control</p> <p>This bit controls the clock gating for SSI module 1. If set, the module receives a clock and functions. Otherwise, the module is unlocked and disabled. If the module is unlocked, a read or write to the module generates a bus fault.</p>
4	SSI0	RO	0x0	<p>SSI0 Clock Gating Control</p> <p>This bit controls the clock gating for SSI module 0. If set, the module receives a clock and functions. Otherwise, the module is unlocked and disabled. If the module is unlocked, a read or write to the module generates a bus fault.</p>
3	reserved	RO	0	Software should not rely on the value of a reserved bit. To provide compatibility with future products, the value of a reserved bit should be preserved across a read-modify-write operation.
2	UART2	RO	0x0	<p>UART2 Clock Gating Control</p> <p>This bit controls the clock gating for UART module 2. If set, the module receives a clock and functions. Otherwise, the module is unlocked and disabled. If the module is unlocked, a read or write to the module generates a bus fault.</p>
1	UART1	RO	0x0	<p>UART1 Clock Gating Control</p> <p>This bit controls the clock gating for UART module 1. If set, the module receives a clock and functions. Otherwise, the module is unlocked and disabled. If the module is unlocked, a read or write to the module generates a bus fault.</p>

Bit/Field	Name	Type	Reset	Description
0	UART0	RO	0x0	UART0 Clock Gating Control This bit controls the clock gating for UART module 0. If set, the module receives a clock and functions. Otherwise, the module is unlocked and disabled. If the module is unlocked, a read or write to the module generates a bus fault.

Register 138: Run Mode Clock Gating Control Register 2 (RCGC2), offset 0x108

This register controls the clock gating logic in normal Run mode. Each bit controls a clock enable for a given interface, function, or module. If set, the module receives a clock and functions. Otherwise, the module is unclocked and disabled (saving power). If the module is unclocked, reads or writes to the module generate a bus fault. The reset state of these bits is 0 (unclocked) unless otherwise noted, so that all functional modules are disabled. It is the responsibility of software to enable the ports necessary for the application. Note that these registers may contain more bits than there are interfaces, functions, or modules to control. This configuration is implemented to assure reasonable code compatibility with other family and future parts. **RCGC2** is the clock configuration register for running operation, **SCGC2** for Sleep operation, and **DCGC2** for Deep-Sleep operation. Setting the **ACG** bit in the **Run-Mode Clock Configuration (RCC)** register specifies that the system uses sleep modes. Note that there must be a delay of 3 system clocks after a module clock is enabled before any registers in that module are accessed.

Important: This register is provided for legacy software support only.

The peripheral-specific Run Mode Clock Gating Control registers (such as **RCGCDMA**) should be used to reset specific peripherals. A write to this legacy register also writes the corresponding bit in the peripheral-specific register. Any bits that are changed by writing to this register can be read back correctly with a read of this register. Software must use the peripheral-specific registers to support modules that are not present in the legacy registers. If software uses a peripheral-specific register to write a legacy peripheral (such as the μ DMA), the write causes proper operation, but the value of that bit is not reflected in this register. If software uses both legacy and peripheral-specific register accesses, the peripheral-specific registers must be accessed by read-modify-write operations that affect only peripherals that are not present in the legacy registers. In this manner, both the peripheral-specific and legacy registers have coherent information.

Run Mode Clock Gating Control Register 2 (RCGC2)

Base 0x400F.E000

Offset 0x108

Type RO, reset 0x0000.0000

	31	30	29	28	27	26	25	24	23	22	21	20	19	18	17	16
	reserved															USB0
Type	RO	RO	RO	RO	RO	RO	RO	RO	RO	RO	RO	RO	RO	RO	RO	RO
Reset	0	0	0	0	0	0	0	0	0	0	0	0	0	0	0	0
	15	14	13	12	11	10	9	8	7	6	5	4	3	2	1	0
	reserved		UDMA	reserved						GPIOG	GPIOF	GPIOE	GPIOD	GPIOC	GPIOB	GPIOA
Type	RO	RO	RO	RO	RO	RO	RO	RO	RO	RO	RO	RO	RO	RO	RO	RO
Reset	0	0	0	0	0	0	0	0	0	0	0	0	0	0	0	0

Bit/Field	Name	Type	Reset	Description
31:17	reserved	RO	0	Software should not rely on the value of a reserved bit. To provide compatibility with future products, the value of a reserved bit should be preserved across a read-modify-write operation.

Bit/Field	Name	Type	Reset	Description
16	USB0	RO	0x0	<p>USB0 Clock Gating Control</p> <p>This bit controls the clock gating for USB module 0. If set, the module receives a clock and functions. Otherwise, the module is unlocked and disabled. If the module is unlocked, a read or write to the module generates a bus fault.</p>
15:14	reserved	RO	0	<p>Software should not rely on the value of a reserved bit. To provide compatibility with future products, the value of a reserved bit should be preserved across a read-modify-write operation.</p>
13	UDMA	RO	0x0	<p>Micro-DMA Clock Gating Control</p> <p>This bit controls the clock gating for micro-DMA. If set, the module receives a clock and functions. Otherwise, the module is unlocked and disabled. If the module is unlocked, a read or write to the module generates a bus fault.</p>
12:7	reserved	RO	0	<p>Software should not rely on the value of a reserved bit. To provide compatibility with future products, the value of a reserved bit should be preserved across a read-modify-write operation.</p>
6	GPIOG	RO	0x0	<p>Port G Clock Gating Control</p> <p>This bit controls the clock gating for Port G. If set, the module receives a clock and functions. Otherwise, the module is unlocked and disabled. If the module is unlocked, a read or write to the module generates a bus fault.</p>
5	GPIOF	RO	0x0	<p>Port F Clock Gating Control</p> <p>This bit controls the clock gating for Port F. If set, the module receives a clock and functions. Otherwise, the module is unlocked and disabled. If the module is unlocked, a read or write to the module generates a bus fault.</p>
4	GPIOE	RO	0x0	<p>Port E Clock Gating Control</p> <p>Port E Clock Gating Control. This bit controls the clock gating for Port E. If set, the module receives a clock and functions. Otherwise, the module is unlocked and disabled. If the module is unlocked, a read or write to the module generates a bus fault.</p>
3	GPIOD	RO	0x0	<p>Port D Clock Gating Control</p> <p>Port D Clock Gating Control. This bit controls the clock gating for Port D. If set, the module receives a clock and functions. Otherwise, the module is unlocked and disabled. If the module is unlocked, a read or write to the module generates a bus fault.</p>
2	GPIOC	RO	0x0	<p>Port C Clock Gating Control</p> <p>This bit controls the clock gating for Port C. If set, the module receives a clock and functions. Otherwise, the module is unlocked and disabled. If the module is unlocked, a read or write to the module generates a bus fault.</p>
1	GPIOB	RO	0x0	<p>Port B Clock Gating Control</p> <p>This bit controls the clock gating for Port B. If set, the module receives a clock and functions. Otherwise, the module is unlocked and disabled. If the module is unlocked, a read or write to the module generates a bus fault.</p>

Bit/Field	Name	Type	Reset	Description
0	GPIOA	RO	0x0	Port A Clock Gating Control This bit controls the clock gating for Port A. If set, the module receives a clock and functions. Otherwise, the module is unlocked and disabled. If the module is unlocked, a read or write to the module generates a bus fault.

Register 139: Sleep Mode Clock Gating Control Register 0 (SCGC0), offset 0x110

This register controls the clock gating logic in Sleep mode. Each bit controls a clock enable for a given interface, function, or module. If set, the module receives a clock and functions. Otherwise, the module is unclocked and disabled (saving power). If the module is unclocked, reads or writes to the module generate a bus fault. The reset state of these bits is 0 (unclocked) unless otherwise noted, so that all functional modules are disabled. It is the responsibility of software to enable the ports necessary for the application. Note that these registers may contain more bits than there are interfaces, functions, or modules to control. This configuration is implemented to assure reasonable code compatibility with other family and future parts. **RCGC0** is the clock configuration register for running operation, **SCGC0** for Sleep operation, and **DCGC0** for Deep-Sleep operation. Setting the **ACG** bit in the **Run-Mode Clock Configuration (RCC)** register specifies that the system uses sleep modes.

Important: This register is provided for legacy software support only.

The peripheral-specific Sleep Mode Clock Gating Control registers (such as **SCGCWD**) should be used to reset specific peripherals. A write to this legacy register also writes the corresponding bit in the peripheral-specific register. Any bits that are changed by writing to this register can be read back correctly with a read of this register. Software must use the peripheral-specific registers to support modules that are not present in the legacy registers. If software uses a peripheral-specific register to write a legacy peripheral (such as Watchdog 1), the write causes proper operation, but the value of that bit is not reflected in this register. If software uses both legacy and peripheral-specific register accesses, the peripheral-specific registers must be accessed by read-modify-write operations that affect only peripherals that are not present in the legacy registers. In this manner, both the peripheral-specific and legacy registers have coherent information.

Sleep Mode Clock Gating Control Register 0 (SCGC0)

Base 0x400F.E000
Offset 0x110
Type RO, reset 0x0000.0040

	31	30	29	28	27	26	25	24	23	22	21	20	19	18	17	16
	reserved			WDT1	reserved		CAN1	CAN0	reserved			PWM0	reserved		ADC1	ADC0
Type	RO	RO	RO	RO	RO	RO	RO	RO	RO	RO	RO	RO	RO	RO	RO	RO
Reset	0	0	0	0	0	0	0	0	0	0	0	0	0	0	0	0
	15	14	13	12	11	10	9	8	7	6	5	4	3	2	1	0
	reserved										reserved	reserved	WDT0	reserved		
Type	RO	RO	RO	RO	RO	RO	RO	RO	RO	RO	RO	RO	RO	RO	RO	RO
Reset	0	0	0	0	0	0	0	0	0	0	1	0	0	0	0	0

Bit/Field	Name	Type	Reset	Description
31:29	reserved	RO	0	Software should not rely on the value of a reserved bit. To provide compatibility with future products, the value of a reserved bit should be preserved across a read-modify-write operation.
28	WDT1	RO	0x0	WDT1 Clock Gating Control This bit controls the clock gating for Watchdog Timer module 1. If set, the module receives a clock and functions. Otherwise, the module is unclocked and disabled. If the module is unclocked, a read or write to the module generates a bus fault.

Bit/Field	Name	Type	Reset	Description
27:26	reserved	RO	0	Software should not rely on the value of a reserved bit. To provide compatibility with future products, the value of a reserved bit should be preserved across a read-modify-write operation.
25	CAN1	RO	0x0	CAN1 Clock Gating Control This bit controls the clock gating for CAN module 1. If set, the module receives a clock and functions. Otherwise, the module is unlocked and disabled. If the module is unlocked, a read or write to the module generates a bus fault.
24	CAN0	RO	0x0	CAN0 Clock Gating Control This bit controls the clock gating for CAN module 0. If set, the module receives a clock and functions. Otherwise, the module is unlocked and disabled. If the module is unlocked, a read or write to the module generates a bus fault.
23:21	reserved	RO	0	Software should not rely on the value of a reserved bit. To provide compatibility with future products, the value of a reserved bit should be preserved across a read-modify-write operation.
20	PWM0	RO	0x0	PWM Clock Gating Control This bit controls the clock gating for the PWM module. If set, the module receives a clock and functions. Otherwise, the module is unlocked and disabled. If the module is unlocked, a read or write to the module generates a bus fault.
19:18	reserved	RO	0	Software should not rely on the value of a reserved bit. To provide compatibility with future products, the value of a reserved bit should be preserved across a read-modify-write operation.
17	ADC1	RO	0x0	ADC1 Clock Gating Control This bit controls the clock gating for ADC module 1. If set, the module receives a clock and functions. Otherwise, the module is unlocked and disabled. If the module is unlocked, a read or write to the module generates a bus fault.
16	ADC0	RO	0x0	ADC0 Clock Gating Control This bit controls the clock gating for ADC module 0. If set, the module receives a clock and functions. Otherwise, the module is unlocked and disabled. If the module is unlocked, a read or write to the module generates a bus fault.
15:7	reserved	RO	0	Software should not rely on the value of a reserved bit. To provide compatibility with future products, the value of a reserved bit should be preserved across a read-modify-write operation.
6	reserved	RO	1	Software should not rely on the value of a reserved bit. To provide compatibility with future products, the value of a reserved bit should be preserved across a read-modify-write operation.
5:4	reserved	RO	0	Software should not rely on the value of a reserved bit. To provide compatibility with future products, the value of a reserved bit should be preserved across a read-modify-write operation.

Bit/Field	Name	Type	Reset	Description
3	WDT0	RO	0x0	WDT0 Clock Gating Control This bit controls the clock gating for the Watchdog Timer module 0. If set, the module receives a clock and functions. Otherwise, the module is unlocked and disabled. If the module is unlocked, a read or write to the module generates a bus fault.
2:0	reserved	RO	0	Software should not rely on the value of a reserved bit. To provide compatibility with future products, the value of a reserved bit should be preserved across a read-modify-write operation.

Register 140: Sleep Mode Clock Gating Control Register 1 (SCGC1), offset 0x114

This register controls the clock gating logic in Sleep mode. Each bit controls a clock enable for a given interface, function, or module. If set, the module receives a clock and functions. Otherwise, the module is unclocked and disabled (saving power). If the module is unclocked, reads or writes to the module generate a bus fault. The reset state of these bits is 0 (unclocked) unless otherwise noted, so that all functional modules are disabled. It is the responsibility of software to enable the ports necessary for the application. Note that these registers may contain more bits than there are interfaces, functions, or modules to control. This configuration is implemented to assure reasonable code compatibility with other family and future parts. **RCGC1** is the clock configuration register for running operation, **SCGC1** for Sleep operation, and **DCGC1** for Deep-Sleep operation. Setting the **ACG** bit in the **Run-Mode Clock Configuration (RCC)** register specifies that the system uses sleep modes.

Important: This register is provided for legacy software support only.

The peripheral-specific Sleep Mode Clock Gating Control registers (such as **SCGCTIMER**) should be used to reset specific peripherals. A write to this legacy register also writes the corresponding bit in the peripheral-specific register. Any bits that are changed by writing to this register can be read back correctly with a read of this register. Software must use the peripheral-specific registers to support modules that are not present in the legacy registers. If software uses a peripheral-specific register to write a legacy peripheral (such as Timer 0), the write causes proper operation, but the value of that bit is not reflected in this register. If software uses both legacy and peripheral-specific register accesses, the peripheral-specific registers must be accessed by read-modify-write operations that affect only peripherals that are not present in the legacy registers. In this manner, both the peripheral-specific and legacy registers have coherent information.

Sleep Mode Clock Gating Control Register 1 (SCGC1)

Base 0x400F.E000
Offset 0x114
Type RO, reset 0x0000.0000

	31	30	29	28	27	26	25	24	23	22	21	20	19	18	17	16
	reserved						COMP1	COMP0	reserved				TIMER3	TIMER2	TIMER1	TIMER0
Type	RO	RO	RO	RO	RO	RO	RO	RO	RO	RO	RO	RO	RO	RO	RO	RO
Reset	0	0	0	0	0	0	0	0	0	0	0	0	0	0	0	0
	15	14	13	12	11	10	9	8	7	6	5	4	3	2	1	0
	reserved	I2C1	reserved	I2C0	reserved		QE1	QE0	reserved		SSI1	SSI0	reserved	UART2	UART1	UART0
Type	RO	RO	RO	RO	RO	RO	RO	RO	RO	RO	RO	RO	RO	RO	RO	RO
Reset	0	0	0	0	0	0	0	0	0	0	0	0	0	0	0	0

Bit/Field	Name	Type	Reset	Description
31:26	reserved	RO	0	Software should not rely on the value of a reserved bit. To provide compatibility with future products, the value of a reserved bit should be preserved across a read-modify-write operation.
25	COMP1	RO	0x0	Analog Comparator 1 Clock Gating This bit controls the clock gating for analog comparator 1. If set, the module receives a clock and functions. Otherwise, the module is unclocked and disabled. If the module is unclocked, a read or write to the module generates a bus fault.

Bit/Field	Name	Type	Reset	Description
24	COMP0	RO	0x0	<p>Analog Comparator 0 Clock Gating</p> <p>This bit controls the clock gating for analog comparator 0. If set, the module receives a clock and functions. Otherwise, the module is unlocked and disabled. If the module is unlocked, a read or write to the module generates a bus fault.</p>
23:20	reserved	RO	0	Software should not rely on the value of a reserved bit. To provide compatibility with future products, the value of a reserved bit should be preserved across a read-modify-write operation.
19	TIMER3	RO	0x0	<p>Timer 3 Clock Gating Control</p> <p>This bit controls the clock gating for General-Purpose Timer module 3. If set, the module receives a clock and functions. Otherwise, the module is unlocked and disabled. If the module is unlocked, a read or write to the module generates a bus fault.</p>
18	TIMER2	RO	0x0	<p>Timer 2 Clock Gating Control</p> <p>This bit controls the clock gating for General-Purpose Timer module 2. If set, the module receives a clock and functions. Otherwise, the module is unlocked and disabled. If the module is unlocked, a read or write to the module generates a bus fault.</p>
17	TIMER1	RO	0x0	<p>Timer 1 Clock Gating Control</p> <p>This bit controls the clock gating for General-Purpose Timer module 1. If set, the module receives a clock and functions. Otherwise, the module is unlocked and disabled. If the module is unlocked, a read or write to the module generates a bus fault.</p>
16	TIMER0	RO	0x0	<p>Timer 0 Clock Gating Control</p> <p>This bit controls the clock gating for General-Purpose Timer module 0. If set, the module receives a clock and functions. Otherwise, the module is unlocked and disabled. If the module is unlocked, a read or write to the module generates a bus fault.</p>
15	reserved	RO	0	Software should not rely on the value of a reserved bit. To provide compatibility with future products, the value of a reserved bit should be preserved across a read-modify-write operation.
14	I2C1	RO	0x0	<p>I2C1 Clock Gating Control</p> <p>This bit controls the clock gating for I2C module 1. If set, the module receives a clock and functions. Otherwise, the module is unlocked and disabled. If the module is unlocked, a read or write to the module generates a bus fault.</p>
13	reserved	RO	0	Software should not rely on the value of a reserved bit. To provide compatibility with future products, the value of a reserved bit should be preserved across a read-modify-write operation.
12	I2C0	RO	0x0	<p>I2C0 Clock Gating Control</p> <p>This bit controls the clock gating for I2C module 0. If set, the module receives a clock and functions. Otherwise, the module is unlocked and disabled. If the module is unlocked, a read or write to the module generates a bus fault.</p>
11:10	reserved	RO	0	Software should not rely on the value of a reserved bit. To provide compatibility with future products, the value of a reserved bit should be preserved across a read-modify-write operation.

Bit/Field	Name	Type	Reset	Description
9	QE11	RO	0x0	<p>QE11 Clock Gating Control</p> <p>This bit controls the clock gating for QE1 module 1. If set, the module receives a clock and functions. Otherwise, the module is unlocked and disabled. If the module is unlocked, a read or write to the module generates a bus fault.</p>
8	QE10	RO	0x0	<p>QE10 Clock Gating Control</p> <p>This bit controls the clock gating for QE1 module 0. If set, the module receives a clock and functions. Otherwise, the module is unlocked and disabled. If the module is unlocked, a read or write to the module generates a bus fault.</p>
7:6	reserved	RO	0	<p>Software should not rely on the value of a reserved bit. To provide compatibility with future products, the value of a reserved bit should be preserved across a read-modify-write operation.</p>
5	SSI1	RO	0x0	<p>SSI1 Clock Gating Control</p> <p>This bit controls the clock gating for SSI module 1. If set, the module receives a clock and functions. Otherwise, the module is unlocked and disabled. If the module is unlocked, a read or write to the module generates a bus fault.</p>
4	SSI0	RO	0x0	<p>SSI0 Clock Gating Control</p> <p>This bit controls the clock gating for SSI module 0. If set, the module receives a clock and functions. Otherwise, the module is unlocked and disabled. If the module is unlocked, a read or write to the module generates a bus fault.</p>
3	reserved	RO	0	<p>Software should not rely on the value of a reserved bit. To provide compatibility with future products, the value of a reserved bit should be preserved across a read-modify-write operation.</p>
2	UART2	RO	0x0	<p>UART2 Clock Gating Control</p> <p>This bit controls the clock gating for UART module 2. If set, the module receives a clock and functions. Otherwise, the module is unlocked and disabled. If the module is unlocked, a read or write to the module generates a bus fault.</p>
1	UART1	RO	0x0	<p>UART1 Clock Gating Control</p> <p>This bit controls the clock gating for UART module 1. If set, the module receives a clock and functions. Otherwise, the module is unlocked and disabled. If the module is unlocked, a read or write to the module generates a bus fault.</p>
0	UART0	RO	0x0	<p>UART0 Clock Gating Control</p> <p>This bit controls the clock gating for UART module 0. If set, the module receives a clock and functions. Otherwise, the module is unlocked and disabled. If the module is unlocked, a read or write to the module generates a bus fault.</p>

Register 141: Sleep Mode Clock Gating Control Register 2 (SCGC2), offset 0x118

This register controls the clock gating logic in Sleep mode. Each bit controls a clock enable for a given interface, function, or module. If set, the module receives a clock and functions. Otherwise, the module is unclocked and disabled (saving power). If the module is unclocked, reads or writes to the module generate a bus fault. The reset state of these bits is 0 (unclocked) unless otherwise noted, so that all functional modules are disabled. It is the responsibility of software to enable the ports necessary for the application. Note that these registers may contain more bits than there are interfaces, functions, or modules to control. This configuration is implemented to assure reasonable code compatibility with other family and future parts. **RCGC2** is the clock configuration register for running operation, **SCGC2** for Sleep operation, and **DCGC2** for Deep-Sleep operation. Setting the **ACG** bit in the **Run-Mode Clock Configuration (RCC)** register specifies that the system uses sleep modes.

Important: This register is provided for legacy software support only.

The peripheral-specific Sleep Mode Clock Gating Control registers (such as **SCGCDMA**) should be used to reset specific peripherals. A write to this legacy register also writes the corresponding bit in the peripheral-specific register. Any bits that are changed by writing to this register can be read back correctly with a read of this register. Software must use the peripheral-specific registers to support modules that are not present in the legacy registers. If software uses a peripheral-specific register to write a legacy peripheral (such as the μ DMA), the write causes proper operation, but the value of that bit is not reflected in this register. If software uses both legacy and peripheral-specific register accesses, the peripheral-specific registers must be accessed by read-modify-write operations that affect only peripherals that are not present in the legacy registers. In this manner, both the peripheral-specific and legacy registers have coherent information.

Sleep Mode Clock Gating Control Register 2 (SCGC2)

Base 0x400F.E000
 Offset 0x118
 Type RO, reset 0x0000.0000

	31	30	29	28	27	26	25	24	23	22	21	20	19	18	17	16
	reserved															USB0
Type	RO	RO	RO	RO	RO	RO	RO	RO	RO	RO	RO	RO	RO	RO	RO	RO
Reset	0	0	0	0	0	0	0	0	0	0	0	0	0	0	0	0
	15	14	13	12	11	10	9	8	7	6	5	4	3	2	1	0
	reserved		UDMA	reserved						GPIOG	GPIOF	GPIOE	GPIOD	GPIOC	GPIOB	GPIOA
Type	RO	RO	RO	RO	RO	RO	RO	RO	RO	RO	RO	RO	RO	RO	RO	RO
Reset	0	0	0	0	0	0	0	0	0	0	0	0	0	0	0	0

Bit/Field	Name	Type	Reset	Description
31:17	reserved	RO	0	Software should not rely on the value of a reserved bit. To provide compatibility with future products, the value of a reserved bit should be preserved across a read-modify-write operation.
16	USB0	RO	0x0	USB0 Clock Gating Control This bit controls the clock gating for USB module 0. If set, the module receives a clock and functions. Otherwise, the module is unclocked and disabled. If the module is unclocked, a read or write to the module generates a bus fault.

Bit/Field	Name	Type	Reset	Description
15:14	reserved	RO	0	Software should not rely on the value of a reserved bit. To provide compatibility with future products, the value of a reserved bit should be preserved across a read-modify-write operation.
13	UDMA	RO	0x0	Micro-DMA Clock Gating Control This bit controls the clock gating for micro-DMA. If set, the module receives a clock and functions. Otherwise, the module is unlocked and disabled. If the module is unlocked, a read or write to the module generates a bus fault.
12:7	reserved	RO	0	Software should not rely on the value of a reserved bit. To provide compatibility with future products, the value of a reserved bit should be preserved across a read-modify-write operation.
6	GPIOG	RO	0x0	Port G Clock Gating Control This bit controls the clock gating for Port G. If set, the module receives a clock and functions. Otherwise, the module is unlocked and disabled. If the module is unlocked, a read or write to the module generates a bus fault.
5	GPIOF	RO	0x0	Port F Clock Gating Control This bit controls the clock gating for Port F. If set, the module receives a clock and functions. Otherwise, the module is unlocked and disabled. If the module is unlocked, a read or write to the module generates a bus fault.
4	GPIOE	RO	0x0	Port E Clock Gating Control Port E Clock Gating Control. This bit controls the clock gating for Port E. If set, the module receives a clock and functions. Otherwise, the module is unlocked and disabled. If the module is unlocked, a read or write to the module generates a bus fault.
3	GPIOD	RO	0x0	Port D Clock Gating Control Port D Clock Gating Control. This bit controls the clock gating for Port D. If set, the module receives a clock and functions. Otherwise, the module is unlocked and disabled. If the module is unlocked, a read or write to the module generates a bus fault.
2	GPIOC	RO	0x0	Port C Clock Gating Control This bit controls the clock gating for Port C. If set, the module receives a clock and functions. Otherwise, the module is unlocked and disabled. If the module is unlocked, a read or write to the module generates a bus fault.
1	GPIOB	RO	0x0	Port B Clock Gating Control This bit controls the clock gating for Port B. If set, the module receives a clock and functions. Otherwise, the module is unlocked and disabled. If the module is unlocked, a read or write to the module generates a bus fault.
0	GPIOA	RO	0x0	Port A Clock Gating Control This bit controls the clock gating for Port A. If set, the module receives a clock and functions. Otherwise, the module is unlocked and disabled. If the module is unlocked, a read or write to the module generates a bus fault.

Register 142: Deep Sleep Mode Clock Gating Control Register 0 (DCGC0), offset 0x120

This register controls the clock gating logic in Deep-Sleep mode. Each bit controls a clock enable for a given interface, function, or module. If set, the module receives a clock and functions. Otherwise, the module is unclocked and disabled (saving power). If the module is unclocked, reads or writes to the module generate a bus fault. The reset state of these bits is 0 (unclocked) unless otherwise noted, so that all functional modules are disabled. It is the responsibility of software to enable the ports necessary for the application. Note that these registers may contain more bits than there are interfaces, functions, or modules to control. This configuration is implemented to assure reasonable code compatibility with other family and future parts. **RCGC0** is the clock configuration register for running operation, **SCGC0** for Sleep operation, and **DCGC0** for Deep-Sleep operation. Setting the **ACG** bit in the **Run-Mode Clock Configuration (RCC)** register specifies that the system uses sleep modes.

Important: This register is provided for legacy software support only.

The peripheral-specific Deep Sleep Mode Clock Gating Control registers (such as **DCGCWD**) should be used to reset specific peripherals. A write to this legacy register also writes the corresponding bit in the peripheral-specific register. Any bits that are changed by writing to this register can be read back correctly with a read of this register. Software must use the peripheral-specific registers to support modules that are not present in the legacy registers. If software uses a peripheral-specific register to write a legacy peripheral (such as Watchdog 1), the write causes proper operation, but the value of that bit is not reflected in this register. If software uses both legacy and peripheral-specific register accesses, the peripheral-specific registers must be accessed by read-modify-write operations that affect only peripherals that are not present in the legacy registers. In this manner, both the peripheral-specific and legacy registers have coherent information.

Deep Sleep Mode Clock Gating Control Register 0 (DCGC0)

Base 0x400F.E000

Offset 0x120

Type RO, reset 0x0000.0040

	31	30	29	28	27	26	25	24	23	22	21	20	19	18	17	16
	reserved			WDT1	reserved		CAN1	CAN0	reserved			PWM0	reserved		ADC1	ADC0
Type	RO	RO	RO	RO	RO	RO	RO	RO	RO	RO	RO	RO	RO	RO	RO	RO
Reset	0	0	0	0	0	0	0	0	0	0	0	0	0	0	0	0
	15	14	13	12	11	10	9	8	7	6	5	4	3	2	1	0
	reserved										reserved	reserved	WDT0	reserved		
Type	RO	RO	RO	RO	RO	RO	RO	RO	RO	RO	RO	RO	RO	RO	RO	RO
Reset	0	0	0	0	0	0	0	0	0	0	1	0	0	0	0	0

Bit/Field	Name	Type	Reset	Description
31:29	reserved	RO	0	Software should not rely on the value of a reserved bit. To provide compatibility with future products, the value of a reserved bit should be preserved across a read-modify-write operation.
28	WDT1	RO	0x0	WDT1 Clock Gating Control This bit controls the clock gating for the Watchdog Timer module 1. If set, the module receives a clock and functions. Otherwise, the module is unclocked and disabled. If the module is unclocked, a read or write to the module generates a bus fault.

Bit/Field	Name	Type	Reset	Description
27:26	reserved	RO	0	Software should not rely on the value of a reserved bit. To provide compatibility with future products, the value of a reserved bit should be preserved across a read-modify-write operation.
25	CAN1	RO	0x0	CAN1 Clock Gating Control This bit controls the clock gating for CAN module 1. If set, the module receives a clock and functions. Otherwise, the module is unlocked and disabled. If the module is unlocked, a read or write to the module generates a bus fault.
24	CAN0	RO	0x0	CAN0 Clock Gating Control This bit controls the clock gating for CAN module 0. If set, the module receives a clock and functions. Otherwise, the module is unlocked and disabled. If the module is unlocked, a read or write to the module generates a bus fault.
23:21	reserved	RO	0	Software should not rely on the value of a reserved bit. To provide compatibility with future products, the value of a reserved bit should be preserved across a read-modify-write operation.
20	PWM0	RO	0x0	PWM Clock Gating Control This bit controls the clock gating for the PWM module. If set, the module receives a clock and functions. Otherwise, the module is unlocked and disabled. If the module is unlocked, a read or write to the module generates a bus fault.
19:18	reserved	RO	0	Software should not rely on the value of a reserved bit. To provide compatibility with future products, the value of a reserved bit should be preserved across a read-modify-write operation.
17	ADC1	RO	0x0	ADC1 Clock Gating Control This bit controls the clock gating for ADC module 1. If set, the module receives a clock and functions. Otherwise, the module is unlocked and disabled. If the module is unlocked, a read or write to the module generates a bus fault.
16	ADC0	RO	0x0	ADC0 Clock Gating Control This bit controls the clock gating for ADC module 0. If set, the module receives a clock and functions. Otherwise, the module is unlocked and disabled. If the module is unlocked, a read or write to the module generates a bus fault.
15:7	reserved	RO	0	Software should not rely on the value of a reserved bit. To provide compatibility with future products, the value of a reserved bit should be preserved across a read-modify-write operation.
6	reserved	RO	1	Software should not rely on the value of a reserved bit. To provide compatibility with future products, the value of a reserved bit should be preserved across a read-modify-write operation.
5:4	reserved	RO	0	Software should not rely on the value of a reserved bit. To provide compatibility with future products, the value of a reserved bit should be preserved across a read-modify-write operation.

Bit/Field	Name	Type	Reset	Description
3	WDT0	RO	0x0	WDT0 Clock Gating Control This bit controls the clock gating for the Watchdog Timer module 0. If set, the module receives a clock and functions. Otherwise, the module is unlocked and disabled. If the module is unlocked, a read or write to the module generates a bus fault.
2:0	reserved	RO	0	Software should not rely on the value of a reserved bit. To provide compatibility with future products, the value of a reserved bit should be preserved across a read-modify-write operation.

Register 143: Deep-Sleep Mode Clock Gating Control Register 1 (DCGC1), offset 0x124

This register controls the clock gating logic in Deep-Sleep mode. Each bit controls a clock enable for a given interface, function, or module. If set, the module receives a clock and functions. Otherwise, the module is unclocked and disabled (saving power). If the module is unclocked, reads or writes to the module generate a bus fault. The reset state of these bits is 0 (unclocked) unless otherwise noted, so that all functional modules are disabled. It is the responsibility of software to enable the ports necessary for the application. Note that these registers may contain more bits than there are interfaces, functions, or modules to control. This configuration is implemented to assure reasonable code compatibility with other family and future parts. **RCGC1** is the clock configuration register for running operation, **SCGC1** for Sleep operation, and **DCGC1** for Deep-Sleep operation. Setting the **ACG** bit in the **Run-Mode Clock Configuration (RCC)** register specifies that the system uses sleep modes.

Important: This register is provided for legacy software support only.

The peripheral-specific Deep Sleep Mode Clock Gating Control registers (such as **DCGCTIMER**) should be used to reset specific peripherals. A write to this legacy register also writes the corresponding bit in the peripheral-specific register. Any bits that are changed by writing to this register can be read back correctly with a read of this register. Software must use the peripheral-specific registers to support modules that are not present in the legacy registers. If software uses a peripheral-specific register to write a legacy peripheral (such as Timer 0), the write causes proper operation, but the value of that bit is not reflected in this register. If software uses both legacy and peripheral-specific register accesses, the peripheral-specific registers must be accessed by read-modify-write operations that affect only peripherals that are not present in the legacy registers. In this manner, both the peripheral-specific and legacy registers have coherent information.

Deep-Sleep Mode Clock Gating Control Register 1 (DCGC1)

Base 0x400F.E000

Offset 0x124

Type RO, reset 0x0000.0000

	31	30	29	28	27	26	25	24	23	22	21	20	19	18	17	16
	reserved						COMP1	COMP0	reserved				TIMER3	TIMER2	TIMER1	TIMER0
Type	RO	RO	RO	RO	RO	RO	RO	RO	RO	RO	RO	RO	RO	RO	RO	RO
Reset	0	0	0	0	0	0	0	0	0	0	0	0	0	0	0	0
	15	14	13	12	11	10	9	8	7	6	5	4	3	2	1	0
	reserved	I2C1	reserved	I2C0	reserved		QE1	QE0	reserved		SSI1	SSI0	reserved	UART2	UART1	UART0
Type	RO	RO	RO	RO	RO	RO	RO	RO	RO	RO	RO	RO	RO	RO	RO	RO
Reset	0	0	0	0	0	0	0	0	0	0	0	0	0	0	0	0

Bit/Field	Name	Type	Reset	Description
31:26	reserved	RO	0	Software should not rely on the value of a reserved bit. To provide compatibility with future products, the value of a reserved bit should be preserved across a read-modify-write operation.
25	COMP1	RO	0x0	Analog Comparator 1 Clock Gating This bit controls the clock gating for analog comparator 1. If set, the module receives a clock and functions. Otherwise, the module is unclocked and disabled. If the module is unclocked, a read or write to the module generates a bus fault.

Bit/Field	Name	Type	Reset	Description
24	COMP0	RO	0x0	<p>Analog Comparator 0 Clock Gating</p> <p>This bit controls the clock gating for analog comparator 0. If set, the module receives a clock and functions. Otherwise, the module is unlocked and disabled. If the module is unlocked, a read or write to the module generates a bus fault.</p>
23:20	reserved	RO	0	Software should not rely on the value of a reserved bit. To provide compatibility with future products, the value of a reserved bit should be preserved across a read-modify-write operation.
19	TIMER3	RO	0x0	<p>Timer 3 Clock Gating Control</p> <p>This bit controls the clock gating for General-Purpose Timer module 3. If set, the module receives a clock and functions. Otherwise, the module is unlocked and disabled. If the module is unlocked, a read or write to the module generates a bus fault.</p>
18	TIMER2	RO	0x0	<p>Timer 2 Clock Gating Control</p> <p>This bit controls the clock gating for General-Purpose Timer module 2. If set, the module receives a clock and functions. Otherwise, the module is unlocked and disabled. If the module is unlocked, a read or write to the module generates a bus fault.</p>
17	TIMER1	RO	0x0	<p>Timer 1 Clock Gating Control</p> <p>This bit controls the clock gating for General-Purpose Timer module 1. If set, the module receives a clock and functions. Otherwise, the module is unlocked and disabled. If the module is unlocked, a read or write to the module generates a bus fault.</p>
16	TIMER0	RO	0x0	<p>Timer 0 Clock Gating Control</p> <p>This bit controls the clock gating for General-Purpose Timer module 0. If set, the module receives a clock and functions. Otherwise, the module is unlocked and disabled. If the module is unlocked, a read or write to the module generates a bus fault.</p>
15	reserved	RO	0	Software should not rely on the value of a reserved bit. To provide compatibility with future products, the value of a reserved bit should be preserved across a read-modify-write operation.
14	I2C1	RO	0x0	<p>I2C1 Clock Gating Control</p> <p>This bit controls the clock gating for I2C module 1. If set, the module receives a clock and functions. Otherwise, the module is unlocked and disabled. If the module is unlocked, a read or write to the module generates a bus fault.</p>
13	reserved	RO	0	Software should not rely on the value of a reserved bit. To provide compatibility with future products, the value of a reserved bit should be preserved across a read-modify-write operation.
12	I2C0	RO	0x0	<p>I2C0 Clock Gating Control</p> <p>This bit controls the clock gating for I2C module 0. If set, the module receives a clock and functions. Otherwise, the module is unlocked and disabled. If the module is unlocked, a read or write to the module generates a bus fault.</p>
11:10	reserved	RO	0	Software should not rely on the value of a reserved bit. To provide compatibility with future products, the value of a reserved bit should be preserved across a read-modify-write operation.

Bit/Field	Name	Type	Reset	Description
9	QE11	RO	0x0	<p>QE11 Clock Gating Control</p> <p>This bit controls the clock gating for QE1 module 1. If set, the module receives a clock and functions. Otherwise, the module is unlocked and disabled. If the module is unlocked, a read or write to the module generates a bus fault.</p>
8	QE10	RO	0x0	<p>QE10 Clock Gating Control</p> <p>This bit controls the clock gating for QE1 module 0. If set, the module receives a clock and functions. Otherwise, the module is unlocked and disabled. If the module is unlocked, a read or write to the module generates a bus fault.</p>
7:6	reserved	RO	0	<p>Software should not rely on the value of a reserved bit. To provide compatibility with future products, the value of a reserved bit should be preserved across a read-modify-write operation.</p>
5	SSI1	RO	0x0	<p>SSI1 Clock Gating Control</p> <p>This bit controls the clock gating for SSI module 1. If set, the module receives a clock and functions. Otherwise, the module is unlocked and disabled. If the module is unlocked, a read or write to the module generates a bus fault.</p>
4	SSI0	RO	0x0	<p>SSI0 Clock Gating Control</p> <p>This bit controls the clock gating for SSI module 0. If set, the module receives a clock and functions. Otherwise, the module is unlocked and disabled. If the module is unlocked, a read or write to the module generates a bus fault.</p>
3	reserved	RO	0	<p>Software should not rely on the value of a reserved bit. To provide compatibility with future products, the value of a reserved bit should be preserved across a read-modify-write operation.</p>
2	UART2	RO	0x0	<p>UART2 Clock Gating Control</p> <p>This bit controls the clock gating for UART module 2. If set, the module receives a clock and functions. Otherwise, the module is unlocked and disabled. If the module is unlocked, a read or write to the module generates a bus fault.</p>
1	UART1	RO	0x0	<p>UART1 Clock Gating Control</p> <p>This bit controls the clock gating for UART module 1. If set, the module receives a clock and functions. Otherwise, the module is unlocked and disabled. If the module is unlocked, a read or write to the module generates a bus fault.</p>
0	UART0	RO	0x0	<p>UART0 Clock Gating Control</p> <p>This bit controls the clock gating for UART module 0. If set, the module receives a clock and functions. Otherwise, the module is unlocked and disabled. If the module is unlocked, a read or write to the module generates a bus fault.</p>

Register 144: Deep Sleep Mode Clock Gating Control Register 2 (DCGC2), offset 0x128

This register controls the clock gating logic in Deep-Sleep mode. Each bit controls a clock enable for a given interface, function, or module. If set, the module receives a clock and functions. Otherwise, the module is unclocked and disabled (saving power). If the module is unclocked, reads or writes to the module generate a bus fault. The reset state of these bits is 0 (unclocked) unless otherwise noted, so that all functional modules are disabled. It is the responsibility of software to enable the ports necessary for the application. Note that these registers may contain more bits than there are interfaces, functions, or modules to control. This configuration is implemented to assure reasonable code compatibility with other family and future parts. **RCGC2** is the clock configuration register for running operation, **SCGC2** for Sleep operation, and **DCGC2** for Deep-Sleep operation. Setting the **ACG** bit in the **Run-Mode Clock Configuration (RCC)** register specifies that the system uses sleep modes.

Important: This register is provided for legacy software support only.

The peripheral-specific Deep Sleep Mode Clock Gating Control registers (such as **DCGCDMA**) should be used to reset specific peripherals. A write to this legacy register also writes the corresponding bit in the peripheral-specific register. Any bits that are changed by writing to this register can be read back correctly with a read of this register. Software must use the peripheral-specific registers to support modules that are not present in the legacy registers. If software uses a peripheral-specific register to write a legacy peripheral (such as the μ DMA), the write causes proper operation, but the value of that bit is not reflected in this register. If software uses both legacy and peripheral-specific register accesses, the peripheral-specific registers must be accessed by read-modify-write operations that affect only peripherals that are not present in the legacy registers. In this manner, both the peripheral-specific and legacy registers have coherent information.

Deep Sleep Mode Clock Gating Control Register 2 (DCGC2)

Base 0x400F.E000
 Offset 0x128
 Type RO, reset 0x0000.0000

	31	30	29	28	27	26	25	24	23	22	21	20	19	18	17	16	
	reserved															USB0	
Type	RO	RO	RO	RO	RO	RO	RO	RO	RO	RO	RO	RO	RO	RO	RO	RO	
Reset	0	0	0	0	0	0	0	0	0	0	0	0	0	0	0	0	
	15	14	13	12	11	10	9	8	7	6	5	4	3	2	1	0	
	reserved		UDMA	reserved						GPIOG		GPIOF	GPIOE	GPIOD	GPIOC	GPIOB	GPIOA
Type	RO	RO	RO	RO	RO	RO	RO	RO	RO	RO	RO	RO	RO	RO	RO	RO	
Reset	0	0	0	0	0	0	0	0	0	0	0	0	0	0	0	0	

Bit/Field	Name	Type	Reset	Description
31:17	reserved	RO	0	Software should not rely on the value of a reserved bit. To provide compatibility with future products, the value of a reserved bit should be preserved across a read-modify-write operation.
16	USB0	RO	0x0	USB0 Clock Gating Control This bit controls the clock gating for USB module 0. If set, the module receives a clock and functions. Otherwise, the module is unclocked and disabled. If the module is unclocked, a read or write to the module generates a bus fault.

Bit/Field	Name	Type	Reset	Description
15:14	reserved	RO	0	Software should not rely on the value of a reserved bit. To provide compatibility with future products, the value of a reserved bit should be preserved across a read-modify-write operation.
13	UDMA	RO	0x0	Micro-DMA Clock Gating Control This bit controls the clock gating for micro-DMA. If set, the module receives a clock and functions. Otherwise, the module is unlocked and disabled. If the module is unlocked, a read or write to the module generates a bus fault.
12:7	reserved	RO	0	Software should not rely on the value of a reserved bit. To provide compatibility with future products, the value of a reserved bit should be preserved across a read-modify-write operation.
6	GPIOG	RO	0x0	Port G Clock Gating Control This bit controls the clock gating for Port G. If set, the module receives a clock and functions. Otherwise, the module is unlocked and disabled. If the module is unlocked, a read or write to the module generates a bus fault.
5	GPIOF	RO	0x0	Port F Clock Gating Control This bit controls the clock gating for Port F. If set, the module receives a clock and functions. Otherwise, the module is unlocked and disabled. If the module is unlocked, a read or write to the module generates a bus fault.
4	GPIOE	RO	0x0	Port E Clock Gating Control Port E Clock Gating Control. This bit controls the clock gating for Port E. If set, the module receives a clock and functions. Otherwise, the module is unlocked and disabled. If the module is unlocked, a read or write to the module generates a bus fault.
3	GPIOD	RO	0x0	Port D Clock Gating Control Port D Clock Gating Control. This bit controls the clock gating for Port D. If set, the module receives a clock and functions. Otherwise, the module is unlocked and disabled. If the module is unlocked, a read or write to the module generates a bus fault.
2	GPIOC	RO	0x0	Port C Clock Gating Control This bit controls the clock gating for Port C. If set, the module receives a clock and functions. Otherwise, the module is unlocked and disabled. If the module is unlocked, a read or write to the module generates a bus fault.
1	GPIOB	RO	0x0	Port B Clock Gating Control This bit controls the clock gating for Port B. If set, the module receives a clock and functions. Otherwise, the module is unlocked and disabled. If the module is unlocked, a read or write to the module generates a bus fault.
0	GPIOA	RO	0x0	Port A Clock Gating Control This bit controls the clock gating for Port A. If set, the module receives a clock and functions. Otherwise, the module is unlocked and disabled. If the module is unlocked, a read or write to the module generates a bus fault.

Register 145: Device Capabilities 9 (DC9), offset 0x190

This register is predefined by the part and can be used to verify ADC digital comparator features.

Important: This register is provided for legacy software support only.

The **ADC Peripheral Properties (ADCPP)** register should be used to determine how many digital comparators are available on the ADC module. A read of this register correctly identifies if legacy comparators are present. Software must use the **ADCPP** register to determine if a comparator that is not supported by the **DCn** registers is present.

Device Capabilities 9 (DC9)

Base 0x400F.E000
Offset 0x190
Type RO, reset 0x00FF.00FF

	31	30	29	28	27	26	25	24	23	22	21	20	19	18	17	16
	reserved								ADC1DC7	ADC1DC6	ADC1DC5	ADC1DC4	ADC1DC3	ADC1DC2	ADC1DC1	ADC1DC0
Type	RO	RO	RO	RO	RO	RO	RO	RO	RO	RO	RO	RO	RO	RO	RO	RO
Reset	0	0	0	0	0	0	0	0	1	1	1	1	1	1	1	1
	15	14	13	12	11	10	9	8	7	6	5	4	3	2	1	0
	reserved								ADC0DC7	ADC0DC6	ADC0DC5	ADC0DC4	ADC0DC3	ADC0DC2	ADC0DC1	ADC0DC0
Type	RO	RO	RO	RO	RO	RO	RO	RO	RO	RO	RO	RO	RO	RO	RO	RO
Reset	0	0	0	0	0	0	0	0	1	1	1	1	1	1	1	1

Bit/Field	Name	Type	Reset	Description
31:24	reserved	RO	0	Software should not rely on the value of a reserved bit. To provide compatibility with future products, the value of a reserved bit should be preserved across a read-modify-write operation.
23	ADC1DC7	RO	0x1	ADC1 DC7 Present When set, indicates that ADC module 1 Digital Comparator 7 is present.
22	ADC1DC6	RO	0x1	ADC1 DC6 Present When set, indicates that ADC module 1 Digital Comparator 6 is present.
21	ADC1DC5	RO	0x1	ADC1 DC5 Present When set, indicates that ADC module 1 Digital Comparator 5 is present.
20	ADC1DC4	RO	0x1	ADC1 DC4 Present When set, indicates that ADC module 1 Digital Comparator 4 is present.
19	ADC1DC3	RO	0x1	ADC1 DC3 Present When set, indicates that ADC module 1 Digital Comparator 3 is present.
18	ADC1DC2	RO	0x1	ADC1 DC2 Present When set, indicates that ADC module 1 Digital Comparator 2 is present.
17	ADC1DC1	RO	0x1	ADC1 DC1 Present When set, indicates that ADC module 1 Digital Comparator 1 is present.
16	ADC1DC0	RO	0x1	ADC1 DC0 Present When set, indicates that ADC module 1 Digital Comparator 0 is present.

Bit/Field	Name	Type	Reset	Description
15:8	reserved	RO	0	Software should not rely on the value of a reserved bit. To provide compatibility with future products, the value of a reserved bit should be preserved across a read-modify-write operation.
7	ADC0DC7	RO	0x1	ADC0 DC7 Present When set, indicates that ADC module 0 Digital Comparator 7 is present.
6	ADC0DC6	RO	0x1	ADC0 DC6 Present When set, indicates that ADC module 0 Digital Comparator 6 is present.
5	ADC0DC5	RO	0x1	ADC0 DC5 Present When set, indicates that ADC module 0 Digital Comparator 5 is present.
4	ADC0DC4	RO	0x1	ADC0 DC4 Present When set, indicates that ADC module 0 Digital Comparator 4 is present.
3	ADC0DC3	RO	0x1	ADC0 DC3 Present When set, indicates that ADC module 0 Digital Comparator 3 is present.
2	ADC0DC2	RO	0x1	ADC0 DC2 Present When set, indicates that ADC module 0 Digital Comparator 2 is present.
1	ADC0DC1	RO	0x1	ADC0 DC1 Present When set, indicates that ADC module 0 Digital Comparator 1 is present.
0	ADC0DC0	RO	0x1	ADC0 DC0 Present When set, indicates that ADC module 0 Digital Comparator 0 is present.

Register 146: Non-Volatile Memory Information (NVMSTAT), offset 0x1A0

This register is predefined by the part and can be used to verify features.

Important: This register is provided for legacy software support only.

The **ROM Third-Party Software (ROMSWMAP)** register should be used to determine the presence of third-party software in the on-chip ROM on this microcontroller. A read of the **TPSW** bit in this register correctly identifies the presence of legacy third-party software. Software should use the **ROMSWMAP** register for software that is not on legacy devices.

Non-Volatile Memory Information (NVMSTAT)

Base 0x400F.E000

Offset 0x1A0

Type RO, reset 0x0000.0001

	31	30	29	28	27	26	25	24	23	22	21	20	19	18	17	16
	reserved															
Type	RO	RO	RO	RO	RO	RO	RO	RO	RO	RO	RO	RO	RO	RO	RO	RO
Reset	0	0	0	0	0	0	0	0	0	0	0	0	0	0	0	0
	15	14	13	12	11	10	9	8	7	6	5	4	3	2	1	0
	reserved															FWB
Type	RO	RO	RO	RO	RO	RO	RO	RO	RO	RO	RO	RO	RO	RO	RO	RO
Reset	0	0	0	0	0	0	0	0	0	0	0	0	0	0	0	1

Bit/Field	Name	Type	Reset	Description
31:1	reserved	RO	0	Software should not rely on the value of a reserved bit. To provide compatibility with future products, the value of a reserved bit should be preserved across a read-modify-write operation.
0	FWB	RO	0x1	32 Word Flash Write Buffer Available When set, indicates that the 32 word Flash memory write buffer feature is available.

6 System Exception Module

This module is an AHB peripheral that handles system-level Cortex-M4 FPU exceptions. For functions with registers mapped into this aperture; if the function is not available on a device, then all writes to the associated registers are ignored and reads return zeros.

6.1 Functional Description

The System Exception module provides control and status of the system-level interrupts. All the interrupt events are ORed together before being sent to the interrupt controller, so the System Exception module can only generate a single interrupt request to the controller at any given time. Software can service multiple interrupt events in a single interrupt service routine by reading the **System Exception Masked Interrupt Status (SYSEXCMIIS)** register. The interrupt events that can trigger a controller-level interrupt are defined in the **System Exception Interrupt Mask (SYSEXCIM)** register by setting the corresponding interrupt mask bits. If interrupts are not used, the raw interrupt status is always visible via the **System Exception Raw Interrupt Status (SYSEXCRIIS)** register. Interrupts are always cleared (for both the **SYSEXCMIIS** and **SYSEXCRIIS** registers) by writing a 1 to the corresponding bit in the **System Exception Interrupt Clear (SYSEXCIC)** register.

6.2 Register Map

Table 6-1 on page 493 lists the System Exception module registers. The offset listed is a hexadecimal increment to the register's address, relative to the System Exception base address of 0x400F.9000.

Note: Spaces in the System Exception register space that are not used are reserved for future or internal use. Software should not modify any reserved memory address.

Table 6-1. System Exception Register Map

Offset	Name	Type	Reset	Description	See page
0x000	SYSEXCRIIS	RO	0x0000.0000	System Exception Raw Interrupt Status	494
0x004	SYSEXCIM	R/W	0x0000.0000	System Exception Interrupt Mask	496
0x008	SYSEXCMIIS	RO	0x0000.0000	System Exception Masked Interrupt Status	498
0x00C	SYSEXCIC	W1C	0x0000.0000	System Exception Interrupt Clear	500

6.3 Register Descriptions

All addresses given are relative to the System Exception base address of 0x400F.9000.

Register 1: System Exception Raw Interrupt Status (SYSEXCRIS), offset 0x000

The **SYSEXCRIS** register is the raw interrupt status register. On a read, this register gives the current raw status value of the corresponding interrupt. A write has no effect.

System Exception Raw Interrupt Status (SYSEXCRIS)

Base 0x400F.9000
 Offset 0x000
 Type RO, reset 0x0000.0000

	31	30	29	28	27	26	25	24	23	22	21	20	19	18	17	16	
	reserved																
Type	RO	RO	RO	RO	RO	RO	RO	RO	RO	RO	RO	RO	RO	RO	RO	RO	
Reset	0	0	0	0	0	0	0	0	0	0	0	0	0	0	0	0	
	15	14	13	12	11	10	9	8	7	6	5	4	3	2	1	0	
	reserved											FPIXCRIS	FPOFCRIS	FPUFCRIS	FPIOCRIS	FPDZCRIS	FPIDCRIS
Type	RO	RO	RO	RO	RO	RO	RO	RO	RO	RO	RO	RO	RO	RO	RO	RO	
Reset	0	0	0	0	0	0	0	0	0	0	0	0	0	0	0	0	

Bit/Field	Name	Type	Reset	Description
31:6	reserved	RO	0x0000.00	Software should not rely on the value of a reserved bit. To provide compatibility with future products, the value of a reserved bit should be preserved across a read-modify-write operation.
5	FPIXCRIS	RO	0	<p>Floating-Point Inexact Exception Raw Interrupt Status</p> <p>Value Description</p> <p>0 No interrupt</p> <p>1 A floating-point inexact exception has occurred.</p> <p>This bit is cleared by writing a 1 to the IXCIC bit in the SYSEXCIC register.</p>
4	FPOFCRIS	RO	0	<p>Floating-Point Overflow Exception Raw Interrupt Status</p> <p>Value Description</p> <p>0 No interrupt</p> <p>1 A floating-point overflow exception has occurred.</p> <p>This bit is cleared by writing a 1 to the OFCIC bit in the SYSEXCIC register.</p>
3	FPUFCRIS	RO	0	<p>Floating-Point Underflow Exception Raw Interrupt Status</p> <p>Value Description</p> <p>0 No interrupt</p> <p>1 A floating-point underflow exception has occurred.</p> <p>This bit is cleared by writing a 1 to the UFCIC bit in the SYSEXCIC register.</p>

Bit/Field	Name	Type	Reset	Description
2	FPIOCRIS	RO	0	<p>Floating-Point Invalid Operation Raw Interrupt Status</p> <p>Value Description</p> <p>0 No interrupt</p> <p>1 A floating-point invalid operation exception has occurred.</p> <p>This bit is cleared by writing a 1 to the <code>IOCIC</code> bit in the SYSEXCIC register.</p>
1	FPDZCRIS	RO	0	<p>Floating-Point Divide By 0 Exception Raw Interrupt Status</p> <p>Value Description</p> <p>0 No interrupt</p> <p>1 A floating-point divide by 0 exception has occurred.</p> <p>This bit is cleared by writing a 1 to the <code>DZCIC</code> bit in the SYSEXCIC register.</p>
0	FPIDCRIS	RO	0	<p>Floating-Point Input Denormal Exception Raw Interrupt Status</p> <p>Value Description</p> <p>0 No interrupt</p> <p>1 A floating-point input denormal exception has occurred.</p> <p>This bit is cleared by writing a 1 to the <code>IDCIC</code> bit in the SYSEXCIC register.</p>

Register 2: System Exception Interrupt Mask (SYSEXCIM), offset 0x004

The **SYSEXCIM** register is the interrupt mask set/clear register.

On a read, this register gives the current value of the mask on the relevant interrupt. Setting a bit allows the corresponding raw interrupt signal to be routed to the interrupt controller. Clearing a bit prevents the raw interrupt signal from being sent to the interrupt controller.

System Exception Interrupt Mask (SYSEXCIM)

Base 0x400F.9000
Offset 0x004
Type R/W, reset 0x0000.0000

	31	30	29	28	27	26	25	24	23	22	21	20	19	18	17	16	
	reserved																
Type	R/W	R/W	R/W	R/W	R/W	R/W	R/W	R/W	R/W	R/W	R/W	R/W	R/W	R/W	R/W	R/W	
Reset	0	0	0	0	0	0	0	0	0	0	0	0	0	0	0	0	
	15	14	13	12	11	10	9	8	7	6	5	4	3	2	1	0	
	reserved											FPIXCIM	FPOFCIM	FPUFCIM	FPIOCIM	FPDZCIM	FPIDCIM
Type	R/W	R/W	R/W	R/W	R/W	R/W	R/W	R/W	R/W	R/W	R/W	R/W	R/W	R/W	R/W	R/W	
Reset	0	0	0	0	0	0	0	0	0	0	0	0	0	0	0	0	

Bit/Field	Name	Type	Reset	Description
31:6	reserved	R/W	0x0000.00	Software should not rely on the value of a reserved bit. To provide compatibility with future products, the value of a reserved bit should be preserved across a read-modify-write operation.
5	FPIXCIM	R/W	0	Floating-Point Inexact Exception Interrupt Mask Value Description 0 The FPIXCRIS interrupt is suppressed and not sent to the interrupt controller. 1 An interrupt is sent to the interrupt controller when the FPIXCRIS bit in the SYSEXCIM register is set.
4	FPOFCIM	R/W	0	Floating-Point Overflow Exception Interrupt Mask Value Description 0 The FPOFCRIS interrupt is suppressed and not sent to the interrupt controller. 1 An interrupt is sent to the interrupt controller when the FPOFCRIS bit in the SYSEXCIM register is set.
3	FPUFCIM	R/W	0	Floating-Point Underflow Exception Interrupt Mask Value Description 0 The FPUFCRIS interrupt is suppressed and not sent to the interrupt controller. 1 An interrupt is sent to the interrupt controller when the FPUFCRIS bit in the SYSEXCIM register is set.

Bit/Field	Name	Type	Reset	Description
2	FPIOCIM	R/W	0	<p>Floating-Point Invalid Operation Interrupt Mask</p> <p>Value Description</p> <p>0 The <code>FPIOCRIS</code> interrupt is suppressed and not sent to the interrupt controller.</p> <p>1 An interrupt is sent to the interrupt controller when the <code>FPIOCRIS</code> bit in the SYSEXCRIS register is set.</p>
1	FPDZCIM	R/W	0	<p>Floating-Point Divide By 0 Exception Interrupt Mask</p> <p>Value Description</p> <p>0 The <code>FPDZCRIS</code> interrupt is suppressed and not sent to the interrupt controller.</p> <p>1 An interrupt is sent to the interrupt controller when the <code>FPDZCRIS</code> bit in the SYSEXCRIS register is set.</p>
0	FPIDCIM	R/W	0	<p>Floating-Point Input Denormal Exception Interrupt Mask</p> <p>Value Description</p> <p>0 The <code>FPIDCRIS</code> interrupt is suppressed and not sent to the interrupt controller.</p> <p>1 An interrupt is sent to the interrupt controller when the <code>FPIDCRIS</code> bit in the SYSEXCRIS register is set.</p>

Register 3: System Exception Masked Interrupt Status (SYSEXC MIS), offset 0x008

The **SYSEXC MIS** register is the masked interrupt status register. On a read, this register gives the current masked status value of the corresponding interrupt. A write has no effect.

System Exception Masked Interrupt Status (SYSEXC MIS)

Base 0x400F.9000
 Offset 0x008
 Type RO, reset 0x0000.0000

	31	30	29	28	27	26	25	24	23	22	21	20	19	18	17	16	
	reserved																
Type	RO	RO	RO	RO	RO	RO	RO	RO	RO	RO	RO	RO	RO	RO	RO	RO	
Reset	0	0	0	0	0	0	0	0	0	0	0	0	0	0	0	0	
	15	14	13	12	11	10	9	8	7	6	5	4	3	2	1	0	
	reserved											FPIXCMIS	FPOFCMIS	FPUFCMIS	FPIOCMIS	FPDZCMIS	FPIDCMIS
Type	RO	RO	RO	RO	RO	RO	RO	RO	RO	RO	RO	RO	RO	RO	RO	RO	
Reset	0	0	0	0	0	0	0	0	0	0	0	0	0	0	0	0	

Bit/Field	Name	Type	Reset	Description
31:6	reserved	RO	0x0000.00	Software should not rely on the value of a reserved bit. To provide compatibility with future products, the value of a reserved bit should be preserved across a read-modify-write operation.
5	FPIXCMIS	RO	0	Floating-Point Inexact Exception Masked Interrupt Status Value Description 0 An interrupt has not occurred or is masked. 1 An unmasked interrupt was signaled due to an inexact exception. This bit is cleared by writing a 1 to the FPIXCMIS bit in the SYSEXCIC register.
4	FPOFCMIS	RO	0	Floating-Point Overflow Exception Masked Interrupt Status Value Description 0 An interrupt has not occurred or is masked. 1 An unmasked interrupt was signaled due to an overflow exception. This bit is cleared by writing a 1 to the FPOFCMIS bit in the SYSEXCIC register.
3	FPUFCMIS	RO	0	Floating-Point Underflow Exception Masked Interrupt Status Value Description 0 An interrupt has not occurred or is masked. 1 An unmasked interrupt was signaled due to an underflow exception. This bit is cleared by writing a 1 to the FPUFCMIS bit in the SYSEXCIC register.

Bit/Field	Name	Type	Reset	Description
2	FPIOCMIS	RO	0	<p>Floating-Point Invalid Operation Masked Interrupt Status</p> <p>Value Description</p> <p>0 An interrupt has not occurred or is masked.</p> <p>1 An unmasked interrupt was signaled due to an invalid operation.</p> <p>This bit is cleared by writing a 1 to the FPIOCIC bit in the SYSEXCIC register.</p>
1	FPDZCMIS	RO	0	<p>Floating-Point Divide By 0 Exception Masked Interrupt Status</p> <p>Value Description</p> <p>0 An interrupt has not occurred or is masked.</p> <p>1 An unmasked interrupt was signaled due to a divide by 0 exception.</p> <p>This bit is cleared by writing a 1 to the FPDZCIC bit in the SYSEXCIC register.</p>
0	FPIDCMIS	RO	0	<p>Floating-Point Input Denormal Exception Masked Interrupt Status</p> <p>Value Description</p> <p>0 An interrupt has not occurred or is masked.</p> <p>1 An unmasked interrupt was signaled due to an input denormal exception.</p> <p>This bit is cleared by writing a 1 to the FPIDCIC bit in the SYSEXCIC register.</p>

Register 4: System Exception Interrupt Clear (SYSEXCIC), offset 0x00C

The **SYSEXCIC** register is the interrupt clear register. On a write of 1, the corresponding interrupt (both raw interrupt and masked interrupt, if enabled) is cleared. A write of 0 has no effect.

System Exception Interrupt Clear (SYSEXCIC)

Base 0x400F.9000
Offset 0x00C
Type W1C, reset 0x0000.0000

	31	30	29	28	27	26	25	24	23	22	21	20	19	18	17	16	
	reserved																
Type	W1C	W1C	W1C	W1C	W1C	W1C	W1C	W1C	W1C	W1C	W1C	W1C	W1C	W1C	W1C	W1C	
Reset	0	0	0	0	0	0	0	0	0	0	0	0	0	0	0	0	
	15	14	13	12	11	10	9	8	7	6	5	4	3	2	1	0	
	reserved											FPIXIC	FPOFCIC	FPUFCIC	FPIOCIC	FPDZCIC	FPIDCIC
Type	W1C	W1C	W1C	W1C	W1C	W1C	W1C	W1C	W1C	W1C	W1C	W1C	W1C	W1C	W1C	W1C	
Reset	0	0	0	0	0	0	0	0	0	0	0	0	0	0	0	0	

Bit/Field	Name	Type	Reset	Description
31:6	reserved	W1C	0x0000.00	Software should not rely on the value of a reserved bit. To provide compatibility with future products, the value of a reserved bit should be preserved across a read-modify-write operation.
5	FPIXIC	W1C	0	Floating-Point Inexact Exception Interrupt Clear Writing a 1 to this bit clears the FPIXCRIS bit in the SYSEXCRCRIS register and the FPIXCMIS bit in the SYSEXCRCMIS register.
4	FPOFCIC	W1C	0	Floating-Point Overflow Exception Interrupt Clear Writing a 1 to this bit clears the FPOFCRIS bit in the SYSEXCRCRIS register and the FPOFCMIS bit in the SYSEXCRCMIS register.
3	FPUFCIC	W1C	0	Floating-Point Underflow Exception Interrupt Clear Writing a 1 to this bit clears the FPUFCRIS bit in the SYSEXCRCRIS register and the FPUFCMIS bit in the SYSEXCRCMIS register.
2	FPIOCIC	W1C	0	Floating-Point Invalid Operation Interrupt Clear Writing a 1 to this bit clears the FPIOCRIS bit in the SYSEXCRCRIS register and the FPIOCMIS bit in the SYSEXCRCMIS register.
1	FPDZCIC	W1C	0	Floating-Point Divide By 0 Exception Interrupt Clear Writing a 1 to this bit clears the FPDZCRIS bit in the SYSEXCRCRIS register and the FPDZCMIS bit in the SYSEXCRCMIS register.
0	FPIDCIC	W1C	0	Floating-Point Input Denormal Exception Interrupt Clear Writing a 1 to this bit clears the FPIDCRIS bit in the SYSEXCRCRIS register and the FPIDCMIS bit in the SYSEXCRCMIS register.

7 Internal Memory

The LM4F231H5QR microcontroller comes with 32 KB of bit-banded SRAM, internal ROM, 256 KB of Flash memory, and 2KB of EEPROM. The Flash memory controller provides a user-friendly interface, making Flash memory programming a simple task. Flash memory is organized in 1-KB independently erasable blocks and memory protection can be applied to the Flash memory on a 2-KB block basis. The EEPROM module provides a well-defined register interface to support accesses to the EEPROM with both a random access style of read and write as well as a rolling or sequential access scheme. A password model allows the application to lock one or more EEPROM blocks to control access on 16-word boundaries.

7.1 Block Diagram

Figure 7-1 on page 501 illustrates the internal SRAM, ROM, and Flash memory blocks and control logic. The dashed boxes in the figure indicate registers residing in the System Control module.

Figure 7-1. Internal Memory Block Diagram

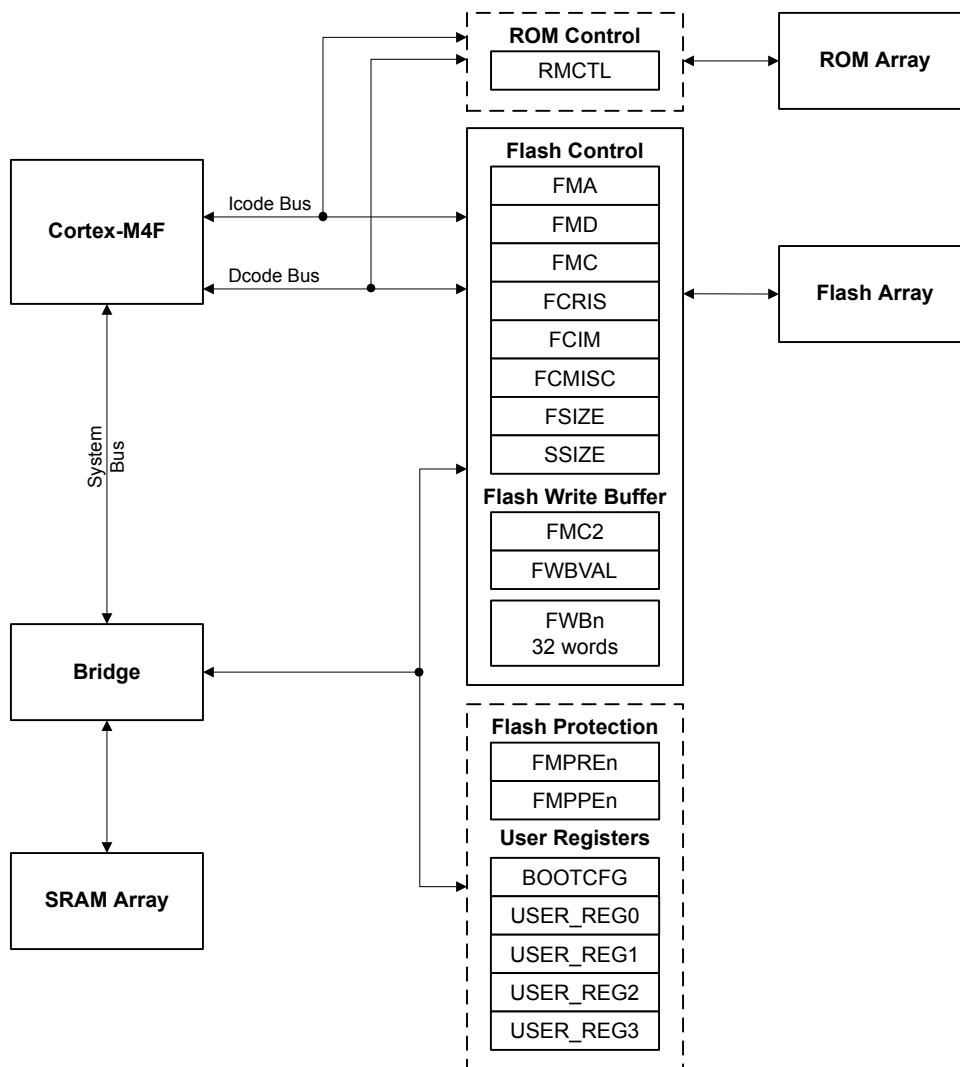
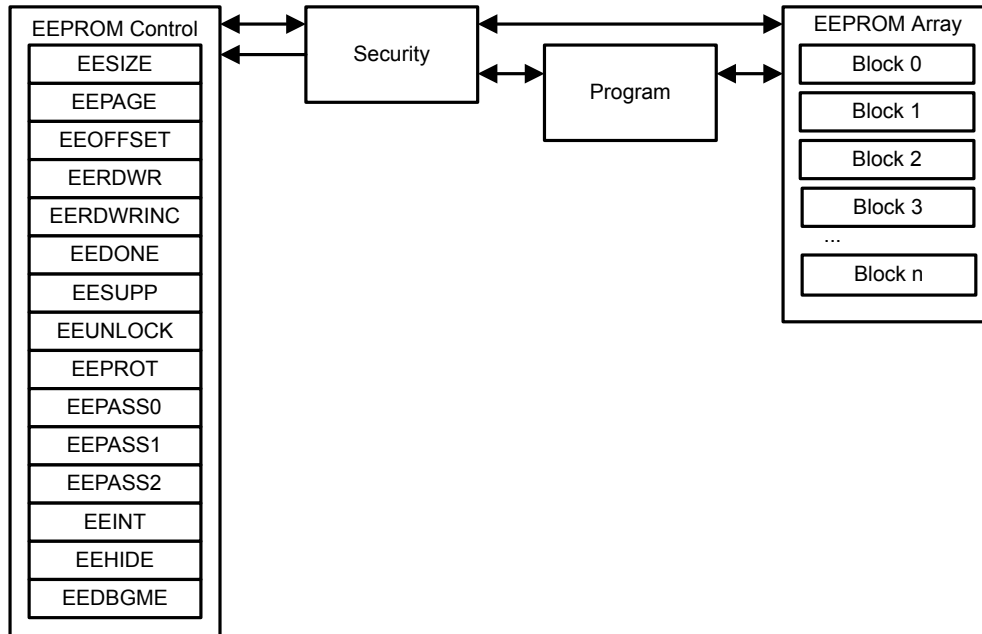

Figure 7-2 on page 502 illustrates the internal EEPROM block and control logic. The EEPROM block is connected to the AHB bus.

Figure 7-2. EEPROM Block Diagram



7.2 Functional Description

This section describes the functionality of the SRAM, ROM, Flash, and EEPROM memories.

Note: The μ DMA controller can transfer data to and from the on-chip SRAM. However, because the Flash memory and ROM are located on a separate internal bus, it is not possible to transfer data from the Flash memory or ROM with the μ DMA controller.

7.2.1 SRAM

The internal SRAM of the Stellaris[®] devices is located at address 0x2000.0000 of the device memory map. To reduce the number of time-consuming read-modify-write (RMW) operations, ARM provides bit-banding technology in the processor. With a bit-band-enabled processor, certain regions in the memory map (SRAM and peripheral space) can use address aliases to access individual bits in a single, atomic operation. The bit-band base is located at address 0x2200.0000.

The bit-band alias is calculated by using the formula:

$$\text{bit-band alias} = \text{bit-band base} + (\text{byte offset} * 32) + (\text{bit number} * 4)$$

For example, if bit 3 at address 0x2000.1000 is to be modified, the bit-band alias is calculated as:

$$0x2200.0000 + (0x1000 * 32) + (3 * 4) = 0x2202.000C$$

With the alias address calculated, an instruction performing a read/write to address 0x2202.000C allows direct access to only bit 3 of the byte at address 0x2000.1000.

For details about bit-banding, see “Bit-Banding” on page 98.

Note: The SRAM is implemented using two 32-bit wide SRAM banks (separate SRAM arrays). The banks are partitioned such that one bank contains all even words (the even bank) and the other contains all odd words (the odd bank). A write access that is followed immediately by a read access to the same bank incurs a stall of a single clock cycle. However, a write to one bank followed by a read of the other bank can occur in successive clock cycles without incurring any delay.

7.2.2 ROM

The internal ROM of the Stellaris device is located at address 0x0100.0000 of the device memory map. Detailed information on the ROM contents can be found in the *Stellaris® ROM User's Guide*.

The ROM contains the following components:

- Stellaris Boot Loader and vector table
- Stellaris Peripheral Driver Library (DriverLib) release for product-specific peripherals and interfaces
- Advanced Encryption Standard (AES) cryptography tables
- Cyclic Redundancy Check (CRC) error detection functionality

The boot loader is used as an initial program loader (when the Flash memory is empty) as well as an application-initiated firmware upgrade mechanism (by calling back to the boot loader). The Peripheral Driver Library APIs in ROM can be called by applications, reducing Flash memory requirements and freeing the Flash memory to be used for other purposes (such as additional features in the application). Advance Encryption Standard (AES) is a publicly defined encryption standard used by the U.S. Government and Cyclic Redundancy Check (CRC) is a technique to validate if a block of data has the same contents as when previously checked.

7.2.2.1 Boot Loader Overview

The Stellaris Boot Loader is used to download code to the Flash memory of a device without the use of a debug interface. When the core is reset, the user has the opportunity to direct the core to execute the ROM Boot Loader or the application in Flash memory by using any GPIO signal in Ports A-H as configured in the **Boot Configuration (BOOTCFG)** register.

At reset, the following sequence is performed:

1. The **BOOTCFG** register is read. If the **EN** bit is clear, the ROM Boot Loader is executed.
2. In the ROM Boot Loader, the status of the specified GPIO pin is compared with the specified polarity. If the status matches the specified polarity, the ROM is mapped to address 0x0000.0000 and execution continues out of the ROM Boot Loader.
3. If the **EN** bit is set or the status doesn't match the specified polarity, the data at address 0x0000.0004 is read, and if the data at this address is 0xFFFF.FFFF, the ROM is mapped to address 0x0000.0000 and execution continues out of the ROM Boot Loader.
4. If there is data at address 0x0000.0004 that is not 0xFFFF.FFFF, the stack pointer (**SP**) is loaded from Flash memory at address 0x0000.0000 and the program counter (**PC**) is loaded from address 0x0000.0004. The user application begins executing.

The boot loader uses a simple packet interface to provide synchronous communication with the device. The speed of the boot loader is determined by the internal oscillator (PIOSC) frequency as it does not enable the PLL. The following serial interfaces can be used:

- UART0
- SSI0
- I²C0
- USB

The data format and communication protocol are identical for the UART0, SSI0, and I2C0 interfaces.

Note: The Flash-memory-resident version of the boot loader also supports CAN.

See the *Stellaris® Boot Loader User's Guide* for information on the boot loader software. The USB boot loader uses the standard Device Firmware Upgrade USB device class.

Considerations When Using the UART Boot Loader in ROM

U0Tx is not driven by the ROM boot loader until the auto-bauding process has completed. If U0Tx is floating during this time, the receiver it is connected to may see transitions on the signal, which could be interpreted by its UART as valid characters. To handle this situation, put a pull-up or pull-down on U0Tx, providing a defined state for the signal until the ROM boot loader begins driving U0Tx. A pull-up is preferred as it indicates that the UART is idle, rather than a pull-down, which indicates a break condition.

7.2.2.2 Stellaris Peripheral Driver Library

The Stellaris Peripheral Driver Library contains a file called `driverlib/rom.h` that assists with calling the peripheral driver library functions in the ROM. The detailed description of each function is available in the *Stellaris® ROM User's Guide*. See the "Using the ROM" chapter of the *Stellaris® Peripheral Driver Library User's Guide* for more details on calling the ROM functions and using `driverlib/rom.h`. The `driverlib/rom_map.h` header file is also provided to aid portability when using different Stellaris devices which might have a different subset of DriverLib functions in ROM. The `driverlib/rom_map.h` header file uses build-time labels to route function calls to the ROM if those functions are available on a given device, otherwise, it routes to Flash-resident versions of the functions.

A table at the beginning of the ROM points to the entry points for the APIs that are provided in the ROM. Accessing the API through these tables provides scalability; while the API locations may change in future versions of the ROM, the API tables will not. The tables are split into two levels; the main table contains one pointer per peripheral which points to a secondary table that contains one pointer per API that is associated with that peripheral. The main table is located at 0x0100.0010, right after the Cortex-M4F vector table in the ROM.

DriverLib functions are described in detail in the *Stellaris® Peripheral Driver Library User's Guide*.

Additional APIs are available for graphics and USB functions, but are not preloaded into ROM. The Stellaris Graphics Library provides a set of graphics primitives and a widget set for creating graphical user interfaces on Stellaris microcontroller-based boards that have a graphical display (for more information, see the *Stellaris® Graphics Library User's Guide*). The Stellaris USB Library is a set of data types and functions for creating USB Device, Host or On-The-Go (OTG) applications on Stellaris microcontroller-based boards (for more information, see the *Stellaris® USB Library User's Guide*).

7.2.2.3 Advanced Encryption Standard (AES) Cryptography Tables

AES is a strong encryption method with reasonable performance and size. AES is fast in both hardware and software, is fairly easy to implement, and requires little memory. AES is ideal for

applications that can use pre-arranged keys, such as setup during manufacturing or configuration. Four data tables used by the XySSL AES implementation are provided in the ROM. The first is the forward S-box substitution table, the second is the reverse S-box substitution table, the third is the forward polynomial table, and the final is the reverse polynomial table. See the *Stellaris® ROM User's Guide* for more information on AES.

7.2.2.4 Cyclic Redundancy Check (CRC) Error Detection

The CRC technique can be used to validate correct receipt of messages (nothing lost or modified in transit), to validate data after decompression, to validate that Flash memory contents have not been changed, and for other cases where the data needs to be validated. A CRC is preferred over a simple checksum (e.g. XOR all bits) because it catches changes more readily. See the *Stellaris® ROM User's Guide* for more information on CRC.

7.2.3 Flash Memory

At system clock speeds of 40 MHz and below, the Flash memory is read in a single cycle. The Flash memory is organized as a set of 1-KB blocks that can be individually erased. An individual 32-bit word can be programmed to change bits from 1 to 0. In addition, a write buffer provides the ability to program 32 continuous words in Flash memory in half the time of programming the words individually. Erasing a block causes the entire contents of the block to be reset to all 1s. The 1-KB blocks are paired into sets of 2-KB blocks that can be individually protected. The protection allows blocks to be marked as read-only or execute-only, providing different levels of code protection. Read-only blocks cannot be erased or programmed, protecting the contents of those blocks from being modified. Execute-only blocks cannot be erased or programmed and can only be read by the controller instruction fetch mechanism, protecting the contents of those blocks from being read by either the controller or a debugger.

7.2.3.1 Prefetch Buffer

The Flash memory controller has a prefetch buffer that is automatically used when the CPU frequency is greater than 40 MHz. In this mode, the Flash memory operates at half of the system clock. The prefetch buffer fetches two 32-bit words per clock allowing instructions to be fetched with no wait states while code is executing linearly. The fetch buffer includes a branch speculation mechanism that recognizes a branch and avoids extra wait states by not reading the next word pair. Also, short loop branches often stay in the buffer. As a result, some branches can be executed with no wait states. Other branches incur a single wait state.

7.2.3.2 Flash Memory Protection

The user is provided two forms of Flash memory protection per 2-KB Flash memory block in four pairs of 32-bit wide registers. The policy for each protection form is controlled by individual bits (per policy per block) in the **FMPPEn** and **FMPREn** registers.

- **Flash Memory Protection Program Enable (FMPPEn)**: If a bit is set, the corresponding block may be programmed (written) or erased. If a bit is cleared, the corresponding block may not be changed.
- **Flash Memory Protection Read Enable (FMPREn)**: If a bit is set, the corresponding block may be executed or read by software or debuggers. If a bit is cleared, the corresponding block may only be executed, and contents of the memory block are prohibited from being read as data.

The policies may be combined as shown in Table 7-1 on page 506.

Table 7-1. Flash Memory Protection Policy Combinations

FMPPEn	FMPREn	Protection
0	0	Execute-only protection. The block may only be executed and may not be written or erased. This mode is used to protect code.
1	0	The block may be written, erased or executed, but not read. This combination is unlikely to be used.
0	1	Read-only protection. The block may be read or executed but may not be written or erased. This mode is used to lock the block from further modification while allowing any read or execute access.
1	1	No protection. The block may be written, erased, executed or read.

A Flash memory access that attempts to read a read-protected block (**FMPREn** bit is set) is prohibited and generates a bus fault. A Flash memory access that attempts to program or erase a program-protected block (**FMPPEn** bit is set) is prohibited and can optionally generate an interrupt (by setting the **AMASK** bit in the **Flash Controller Interrupt Mask (FCIM)** register) to alert software developers of poorly behaving software during the development and debug phases. Note that if a **FMPREn** bit is cleared, all read accesses to the Flash memory block are disallowed, including any data accesses. Care must be taken not to store required data in a Flash memory block that has the associated **FMPREn** bit cleared.

The factory settings for the **FMPREn** and **FMPPEn** registers are a value of 1 for all implemented banks. These settings create a policy of open access and programmability. The register bits may be changed by clearing the specific register bit. The changes are effective immediately, but are not permanent until the register is committed (saved), at which point the bit change is permanent. If a bit is changed from a 1 to a 0 and not committed, it may be restored by executing a power-on reset sequence. The changes are committed using the **Flash Memory Control (FMC)** register. Details on programming these bits are discussed in “Non-Volatile Register Programming” on page 508.

7.2.3.3 Interrupts

The Flash memory controller can generate interrupts when the following conditions are observed:

- Programming Interrupt - signals when a program or erase action is complete.
- Access Interrupt - signals when a program or erase action has been attempted on a 2-kB block of memory that is protected by its corresponding **FMPPEn** bit.

The interrupt events that can trigger a controller-level interrupt are defined in the **Flash Controller Masked Interrupt Status (FCMIS)** register (see page 524) by setting the corresponding **MASK** bits. If interrupts are not used, the raw interrupt status is always visible via the **Flash Controller Raw Interrupt Status (FCRIS)** register (see page 521).

Interrupts are always cleared (for both the **FCMIS** and **FCRIS** registers) by writing a 1 to the corresponding bit in the **Flash Controller Masked Interrupt Status and Clear (FCMISC)** register (see page 526).

7.2.3.4 Flash Memory Programming

The Stellaris devices provide a user-friendly interface for Flash memory programming. All erase/program operations are handled via three registers: **Flash Memory Address (FMA)**, **Flash Memory Data (FMD)**, and **Flash Memory Control (FMC)**. Note that if the debug capabilities of the microcontroller have been deactivated, resulting in a "locked" state, a recovery sequence must be performed in order to reactivate the debug module. See “Recovering a “Locked” Microcontroller” on page 206.

During a Flash memory operation (write, page erase, or mass erase) access to the Flash memory is inhibited. As a result, instruction and literal fetches are held off until the Flash memory operation is complete. If instruction execution is required during a Flash memory operation, the code that is executing must be placed in SRAM and executed from there while the flash operation is in progress.

Note: When programming Flash memory, the following characteristics of the memory must be considered:

- Only an erase can change bits from 0 to 1.
- A write can only change bits from 1 to 0. If the write attempts to change a 0 to a 1, the write fails and no bits are changed.
- A flash operation can be started before entering Sleep or Deep-sleep mode (using the wait for interrupt instruction, `WFI`), but will not complete while in Sleep or Deep-sleep. Instead, the operation completes after an event has woken the system. This means that you cannot rely on the `PRIS` bit in the **Flash Controller Raw Interrupt Status (FCRIS)** register to actually wake the device from Sleep or Deep-Sleep.

To program a 32-bit word

1. Write source data to the **FMD** register.
2. Write the target address to the **FMA** register.
3. Write the Flash memory write key and the `WRITE` bit (a value of `0xA442.0001`) to the **FMC** register.
4. Poll the **FMC** register until the `WRITE` bit is cleared.

To perform an erase of a 1-KB page

1. Write the page address to the **FMA** register.
2. Write the Flash memory write key and the `ERASE` bit (a value of `0xA442.0002`) to the **FMC** register.
3. Poll the **FMC** register until the `ERASE` bit is cleared or, alternatively, enable the programming interrupt using the `PMASK` bit in the **FCIM** register.

To perform a mass erase of the Flash memory

1. Write the Flash memory write key and the `MERASE` bit (a value of `0xA442.0004`) to the **FMC** register.
2. Poll the **FMC** register until the `MERASE` bit is cleared or, alternatively, enable the programming interrupt using the `PMASK` bit in the **FCIM** register.

7.2.3.5 32-Word Flash Memory Write Buffer

A 32-word write buffer provides the capability to perform faster write accesses to the Flash memory by programming 2 32-bit words at a time, allowing 32 words to be programmed in the same time as 16. The data for the buffered write is written to the **Flash Write Buffer (FWBn)** registers.

The registers are 32-word aligned with Flash memory, and therefore the register **FWB0** corresponds with the address in **FMA** where bits [6:0] of **FMA** are all 0. **FWB1** corresponds with the address in **FMA** + 0x4 and so on. Only the **FWBn** registers that have been updated since the previous buffered Flash memory write operation are written. The **Flash Write Buffer Valid (FWBVAL)** register shows which registers have been written since the last buffered Flash memory write operation. This register contains a bit for each of the 32 **FWBn** registers, where bit[n] of **FWBVAL** corresponds to **FWBn**. The **FWBn** register has been updated if the corresponding bit in the **FWBVAL** register is set.

To program 32 words with a single buffered Flash memory write operation

1. Write the source data to the **FWBn** registers.
2. Write the target address to the **FMA** register. This must be a 32-word aligned address (that is, bits [6:0] in **FMA** must be 0s).
3. Write the Flash memory write key and the **WRBUF** bit (a value of 0xA442.0001) to the **FMC2** register.
4. Poll the **FMC2** register until the **WRBUF** bit is cleared or wait for the **PMIS** interrupt to be signaled.

7.2.3.6 Non-Volatile Register Programming

This section discusses how to update the registers shown in Table 7-2 on page 509 that are resident within the Flash memory itself. These registers exist in a separate space from the main Flash memory array and are not affected by an ERASE or MASS ERASE operation. With the exception of the **Boot Configuration (BOOTCFG)** register, the settings in these registers can be written, their functions verified, and their values read back before they are committed, at which point they become non-volatile. If a value in one of these registers has not been committed, a power-on reset restores the last committed value or the default value if the register has never been committed. Other types of reset have no effect. Once the register contents are committed, the only way to restore the factory default values is to perform the sequence described in "Recovering a "Locked" Microcontroller" on page 206.

To write to a non-volatile register:

- Bits can only be changed from 1 to 0.
- For all registers except the **BOOTCFG** register, write the data to the register address provided in the register description. For the **BOOTCFG** register, write the data to the **FMD** register.
- The registers can be read to verify their contents. To verify what is to be stored in the **BOOTCFG** register, read the **FMD** register. Reading the **BOOTCFG** register returns the previously committed value or the default value if the register has never been committed.
- The new values are effectively immediately for all registers except **BOOTCFG**, as the new value for the register is not stored in the register until it has been committed.
- Prior to committing the register value, a power-on reset restores the last committed value or the default value if the register has never been committed.

To commit a new value to a non-volatile register:

- Write the data as described above.
- Write to the **FMA** register the value shown in Table 7-2 on page 509.

- Write the Flash memory write key and set the **COMT** bit in the **FMC** register. These values must be written to the **FMC** register at the same time.
- Committing a non-volatile register has the same timing as a write to regular Flash memory, defined by T_{PROG64} , as shown in Table 24-19 on page 1334. Software can poll the **COMT** bit in the **FMC** register to determine when the operation is complete, or an interrupt can be enabled by setting the **PMASK** bit in the **FCIM** register.
- When committing the **BOOTCFG** register, the **INVDRIS** bit in the **FCRIS** register is set if a bit that has already been committed as a 0 is attempted to be committed as a 1.
- Once the value has been committed, a power-on reset has no effect on the register contents.
- Changes to the **BOOTCFG** register are effective after the next power-on reset.
- Once the **NW** bit has been changed to 0 and committed, further changes to the **BOOTCFG** register are not allowed.

Important: After being committed, these registers can only be restored to their factory default values by performing the sequence described in “Recovering a “Locked” Microcontroller” on page 206. The mass erase of the main Flash memory array caused by the sequence is performed prior to restoring these registers.

Table 7-2. User-Programmable Flash Memory Resident Registers

Register to be Committed	FMA Value	Data Source
FMPRE0	0x0000.0000	FMPRE0
FMPRE1	0x0000.0002	FMPRE1
FMPRE2	0x0000.0004	FMPRE2
FMPRE3	0x0000.0006	FMPRE3
FMPPE0	0x0000.0001	FMPPE0
FMPPE1	0x0000.0003	FMPPE1
FMPPE2	0x0000.0005	FMPPE2
FMPPE3	0x0000.0007	FMPPE3
USER_REG0	0x8000.0000	USER_REG0
USER_REG1	0x8000.0001	USER_REG1
USER_REG2	0x8000.0002	USER_REG2
USER_REG3	0x8000.0003	USER_REG3
BOOTCFG	0x7510.0000	FMD

7.2.4 EEPROM

The LM4F231H5QR microcontroller includes an EEPROM with the following features:

- 2K bytes of memory accessible as 512 32-bit words
- 32 blocks of 16 words (64 bytes) each
- Built-in wear leveling
- Access protection per block

- Lock protection option for the whole peripheral as well as per block using 32-bit to 96-bit unlock codes (application selectable)
- Interrupt support for write completion to avoid polling
- Endurance of 500K writes (when writing at fixed offset in every alternate page in circular fashion) to 15M operations (when cycling through two pages) per each 2-page block.

7.2.4.1 Functional Description

The EEPROM module provides a well-defined register interface to support accesses to the EEPROM with both a random access style of read and write as well as a rolling or sequential access scheme.

A protection mechanism allows locking EEPROM blocks to prevent writes under a set of circumstances as well as reads under the same or different circumstances. The password model allows the application to lock one or more EEPROM blocks to control access on 16-word boundaries.

Important: The configuration of the system clock must not be changed while an EEPROM operation is in process. Software must wait until the `WORKING` bit in the **EEPROM Done Status (EEDONE)** register is clear before making any changes to the system clock.

Blocks

There are 32 blocks of 16 words each in the EEPROM. Bytes and half-words can be read, and these accesses do not have to occur on a word boundary. The entire word is read and any unneeded data is simply ignored. They are writable only on a word basis. To write a byte, it is necessary to read the word value, modify the appropriate byte, and write the word back.

Each block is addressable as an offset within the EEPROM, using a block select register. Each word is offset addressable within the selected block.

The current block is selected by the **EEPROM Current Block (EEBLOCK)** register. The current offset is selected and checked for validity by the **EEPROM Current Offset (EEOFFSET)** register. The application may write the **EEOFFSET** register any time, and it is also automatically incremented when the **EEPROM Read-Write with Increment (EERDWRINC)** register is accessed. However, the **EERDWRINC** register does not increment the block number, but instead wraps within the block.

Blocks are individually protectable. Attempts to read from a block for which the application does not have permission return `0xFFFF.FFFF`. Attempts to write into a block for which the application does not have permission results in an error in the **EEDONE** register.

Timing Considerations

After enabling or resetting the EEPROM module, software must wait until the `WORKING` bit in the **EEDONE** register is clear before accessing any EEPROM registers.

In the event that there are Flash memory writes or erases and EEPROM writes active, it is possible for the EEPROM process to be interrupted by the Flash memory write/erase and then continue after the Flash memory write is completed. This action may change the amount of time that the EEPROM operation takes.

EEPROM operations must be completed before entering Sleep or Deep-Sleep mode. Ensure the EEPROM operations have completed by checking the **EEPROM Done Status (EEDONE)** register before issuing a `WFI` instruction to enter Sleep or Deep-Sleep.

Reads of words within a block are at direct speed, which means that wait states are automatically generated if the system clock is faster than the speed of the EEPROM. The read access time is specified in Table 24-20 on page 1334.

Writing the **EEOFFSET** register also does not incur any penalties.

Writing the **EEBLOCK** register is not delayed, but any attempt to access data within that block is delayed by 4 clocks after writing **EEBLOCK**. This time is used to load block specific information.

Writes to words within a block are delayed by a variable amount of time. The application may use an interrupt to be notified when the write is done, or alternatively poll for the done status in the **EEDONE** register. The variability ranges from the write timing of the EEPROM to the erase timing of EEPROM, where the erase timing is less than the write timing of most external EEPROMs.

Locking and Passwords

The EEPROM can be locked at both the module level and the block level. The lock is controlled by a password that is stored in the **EEPROM Password (EEPASSn)** registers and can be any 32-bit to 96-bit value other than all 1s. Block 0 is the master block, the password for block 0 protects the control registers as well as all other blocks. Each block can be further protected with a password for that block.

If a password is registered for block 0, then the whole module is locked at reset. The locking behavior is such that blocks 1 to 31 are inaccessible until block 0 is unlocked, and block 0 follows the rules defined by its protection bits. As a result, the **EEBLOCK** register cannot be changed from 0 until block 0 is unlocked.

A password registered with any block, including block 0, allows for protection rules that control access of that block based on whether it is locked or unlocked. Generally, the lock can be used to prevent write accesses when locked or can prevent read and write accesses when locked.

All password protected blocks are locked at reset. To unlock a block, the correct password value must be written to the **EEPROM Unlock (EEUNLOCK)** register by writing to it once, twice, or three times, depending on the size of the password. A block or the module may be re-locked by writing 0xFFFF.FFFF to the **EEUNLOCK** register because 0xFFFF.FFFF is not a valid password.

Protection and Access Control

The protection bits provide discrete control of read and write access for each block which allows various protection models per block, including:

- Without password: Readable and writable at any time. This mode is the default when there is no password.
- Without password: Readable but not writable.
- With password: Readable, but only writable when unlocked by the password. This mode is the default when there is a password.
- With password: Readable or writable only when unlocked.
- With password: Readable only when unlocked, not writable.

Additionally, access protection may be applied based on the processor mode. This configuration allows for supervisor-only access or supervisor and user access, which is the default. Supervisor-only access mode also prevents access by the μ DMA and Debugger.

Additionally, the master block may be used to control access protection for the protection mechanism itself. If access control for block 0 is for supervisor only, then the whole module may only be accessed in supervisor mode.

Note that for blocks 1 to 31, they are inaccessible for read or write if block 0 has a password and it is not unlocked. If block 0 has a master password, then the strictest protection defined for block 0 or an individual block is implemented on the remaining blocks.

Hidden Blocks

Hiding provides a temporary form of protection. Every block except block 0 can be hidden, which prevents all accesses until the next reset.

This mechanism can allow a boot or initialization routine to access some data which is then made inaccessible to all further accesses. Because boot and initialization routines control the capabilities of the application, hidden blocks provide a powerful isolation of the data when debug is disabled.

A typical use model would be to have the initialization code store passwords, keys, and/or hashes to use for verification of the rest of the application. Once performed, the block is then hidden and made inaccessible until the next reset which then re-enters the initialization code.

Power and Reset Safety

Once the **EEDONE** register indicates that a location has been successfully written, the data is retained until that location is written again. There is no power or reset race after the **EEDONE** register indicates a write has completed.

Interrupt Control

The EEPROM module allows for an interrupt when a write completes to eliminate the need for polling. The interrupt can be used to drive an application ISR which can then write more words or verify completion. The interrupt mechanism is used any time the **EEDONE** register goes from working to done, whether because of an error or the successful completion of a program or erase operation. This interrupt mechanism works for data writes, writes to password and protection registers, forced erase by the **EEPROM Support Control and Status (EESUPP)** register, and mass erase using the **EEPROM Debug Mass Erase (EEDGBME)** register. The EEPROM interrupt is signaled to the core using the Flash memory interrupt vector. Software can determine that the source of the interrupt was the EEPROM by examining bit 2 of the **Flash Controller Masked Interrupt Status and Clear (FCMISC)** register.

Theory of Operation

The EEPROM operates using a traditional Flash bank model which implements EEPROM-type cells, but uses sector erase. Additionally, words are replicated in the pages to allow 500K+ erase cycles when needed, which means that each word has a latest version. As a result, a write creates a new version of the word in a new location, making the previous value obsolete.

Each sector contains two blocks. Each block contains locations for the active copy plus six redundant copies. Passwords, protection bits, and control data are all stored in the pages.

When a page runs out of room to store the latest version of a word, a copy buffer is used. The copy buffer copies the latest words of each block. The original page is then erased. Finally, the copy buffer contents are copied back to the page. This mechanism ensures that data cannot be lost due to power down, even during an operation. The EEPROM mechanism properly tracks all state information to provide complete safety and protection. Although it should not normally be possible, errors during programming can occur in certain circumstances, for example, the voltage rail dropping during programming. In these cases, the **EESUPP** register can be used to finish an operation as described in the section called "Error During Programming" on page 513.

Manual Copy Buffer Erase

The copy buffer is only used when a main block is full because a word has been written seven times and there is no more room to store its latest version. In this situation, the latest versions of all the words in the block are copied to the copy buffer, allowing the main block to be erased safely, providing power down safety. If the copy buffer itself is full, then it must first be erased, which adds extra time. By performing a manual erase of the copy buffer, this overhead does not occur during a future write access. The `EREQ` bit in the **EESUPP** register is set if the copy buffer must be erased. If so, the `START` bit can be written by the application to force the erase at a more convenient time. The **EEDONE** and **EEINT** registers can be used to detect completion.

Error During Programming

Operations such as data-write, password set, protection set, and copy buffer erase may perform multiple operations. For example, a normal write performs two underlying writes: the control word write and the data write. If the control word writes but the data fails (for example, due to a voltage drop), the overall write fails with indication provided in the **EEDONE** register. Failure and the corrective action is broken down by the type of operation:

- If a normal write fails such that the control word is written but the data fails to write, the safe course of action is to retry the operation once the system is otherwise stable, for example, when the voltage is stabilized. After the retry, the control word and write data are advanced to the next location.
- If a password or protection write fails, the safe course of action is to retry the operation once the system is otherwise stable. In the event that multi-word passwords may be written outside of a manufacturing or bring-up mode, care must be taken to ensure all words are written in immediate succession. If not, then partial password unlock would need to be supported to recover.
- If the word write requires the block to be written to the copy buffer, then it is possible to fail or lose power during the subsequent operations. A control word mechanism is used to track what step the EEPROM was in if a failure occurs. If not completed, the **EESUPP** register indicates the partial completion, and the **EESUPP** `START` bit can be written to allow it to continue to completion.
- If a copy buffer erase fails or power is lost while erasing, the **EESUPP** register indicates it is not complete and allows it to be restarted

After a reset and prior to writing any data to the EEPROM, software must read the **EESUPP** register and check for the presence of any error condition which may indicate that a write or erase was in progress when the system was reset due to a voltage drop. If either the `PRETRY` or `ERETRY` bits are set, the peripheral should be reset by setting and then clearing the `R0` bit in the **EEPROM Software Reset (SREEPROM)** register and waiting for the `WORKING` bit in the **EEDONE** register to clear before again checking the **EESUPP** register for error indicators. This procedure should allow the EEPROM to recover from the write or erase error. In very isolated cases, the **EESUPP** register may continue to register an error after this operation, in which case the reset should be repeated. After recovery, the application should rewrite the data which was being programmed when the initial failure occurred.

Endurance

Endurance is per meta-block which is 2 blocks. Endurance is measured in two ways:

1. To the application, it is the number of writes that can be performed.

2. To the microcontroller, it is the number of erases that can be performed on the meta-block.

Because of the second measure, the number of writes depends on how the writes are performed. For example:

- One word can be written more than 500K times, but, these writes impact the meta-block that the word is within. As a result, writing one word 500K times, then trying to write a nearby word 500K times is not assured to work. To ensure success, the words should be written more in parallel.
- All words can be written in a sweep with a total of more than 500K sweeps which updates all words more than 500K times.
- Different words can be written such that any or all words can be written more than 500K times when write counts per word stay about the same. For example, offset 0 could be written 3 times, then offset 1 could be written 2 times, then offset 2 is written 4 times, then offset 1 is written twice, then offset 0 is written again. As a result, all 3 offsets would have 4 writes at the end of the sequence. This kind of balancing within 7 writes maximizes the endurance of different words within the same meta-block.

7.2.4.2 EEPROM Initialization and Configuration

Before writing to any EEPROM registers, the clock to the EEPROM module must be enabled, see page 334.

A common setup is as follows:

- Block 0 has a password.
- Block 0 is readable by all, but only writable when unlocked.
- Block 0 has an ID and other public data.

In this configuration, the ID is readable any time, but the rest of the EEPROM is locked to accesses by the application. The rest of the blocks only become available when parts of the application that are allowed to access the EEPROM choose to unlock block 0.

7.3 Register Map

Table 7-3 on page 514 lists the ROM Controller register and the Flash memory and control registers. The offset listed is a hexadecimal increment to the particular memory controller's base address. The Flash memory register offsets are relative to the Flash memory control base address of 0x400F.D000. The EEPROM registers are relative to the EEPROM base address of 0x400A.F000. The ROM and Flash memory protection register offsets are relative to the System Control base address of 0x400F.E000.

Table 7-3. Flash Register Map

Offset	Name	Type	Reset	Description	See page
Flash Memory Registers (Flash Control Offset)					
0x000	FMA	R/W	0x0000.0000	Flash Memory Address	517
0x004	FMD	R/W	0x0000.0000	Flash Memory Data	518
0x008	FMC	R/W	0x0000.0000	Flash Memory Control	519

Table 7-3. Flash Register Map (continued)

Offset	Name	Type	Reset	Description	See page
0x00C	FCRIS	RO	0x0000.0000	Flash Controller Raw Interrupt Status	521
0x010	FCIM	R/W	0x0000.0000	Flash Controller Interrupt Mask	524
0x014	FCMISC	R/W1C	0x0000.0000	Flash Controller Masked Interrupt Status and Clear	526
0x020	FMC2	R/W	0x0000.0000	Flash Memory Control 2	529
0x030	FWBVAL	R/W	0x0000.0000	Flash Write Buffer Valid	530
0x100 - 0x17C	FWBn	R/W	0x0000.0000	Flash Write Buffer n	531
0xFC0	FSIZE	RO	0x0000.007F	Flash Size	532
0xFC4	SSIZE	RO	0x0000.007F	SRAM Size	533
0xFCC	ROMSWMAP	RO	0x0000.0000	ROM Software Map	534
EEPROM Registers (EEPROM Control Offset)					
0x000	EESIZE	RO	0x0020.0200	EEPROM Size Information	535
0x004	EEBLOCK	R/W	0x0000.0000	EEPROM Current Block	536
0x008	EEOFFSET	R/W	0x0000.0000	EEPROM Current Offset	537
0x010	EERDWR	R/W	-	EEPROM Read-Write	538
0x014	EERDWRINC	R/W	-	EEPROM Read-Write with Increment	539
0x018	EEDONE	RO	0x0000.0000	EEPROM Done Status	540
0x01C	EESUPP	R/W	-	EEPROM Support Control and Status	542
0x020	EEUNLOCK	R/W	-	EEPROM Unlock	544
0x030	EEPROT	R/W	0x0000.0000	EEPROM Protection	545
0x034	EEPASS0	R/W	-	EEPROM Password	546
0x038	EEPASS1	R/W	-	EEPROM Password	546
0x03C	EEPASS2	R/W	-	EEPROM Password	546
0x040	EEINT	R/W	0x0000.0000	EEPROM Interrupt	547
0x050	EEHIDE	R/W	0x0000.0000	EEPROM Block Hide	548
0x080	EEDBGME	R/W	0x0000.0000	EEPROM Debug Mass Erase	549
0xFC0	EEPROMPP	RO	0x0000.001F	EEPROM Peripheral Properties	550
Memory Registers (System Control Offset)					
0x0F0	RMCTL	R/W1C	-	ROM Control	551
0x130	FMPRE0	R/W	0xFFFF.FFFF	Flash Memory Protection Read Enable 0	552
0x200	FMPRE0	R/W	0xFFFF.FFFF	Flash Memory Protection Read Enable 0	552
0x134	FMPPE0	R/W	0xFFFF.FFFF	Flash Memory Protection Program Enable 0	553

Table 7-3. Flash Register Map (continued)

Offset	Name	Type	Reset	Description	See page
0x400	FMPPE0	R/W	0xFFFF.FFFF	Flash Memory Protection Program Enable 0	553
0x1D0	BOOTCFG	RO	0xFFFF.FFFE	Boot Configuration	555
0x1E0	USER_REG0	R/W	0xFFFF.FFFF	User Register 0	558
0x1E4	USER_REG1	R/W	0xFFFF.FFFF	User Register 1	558
0x1E8	USER_REG2	R/W	0xFFFF.FFFF	User Register 2	558
0x1EC	USER_REG3	R/W	0xFFFF.FFFF	User Register 3	558
0x204	FMPRE1	R/W	0xFFFF.FFFF	Flash Memory Protection Read Enable 1	552
0x208	FMPRE2	R/W	0xFFFF.FFFF	Flash Memory Protection Read Enable 2	552
0x20C	FMPRE3	R/W	0xFFFF.FFFF	Flash Memory Protection Read Enable 3	552
0x404	FMPPE1	R/W	0xFFFF.FFFF	Flash Memory Protection Program Enable 1	553
0x408	FMPPE2	R/W	0xFFFF.FFFF	Flash Memory Protection Program Enable 2	553
0x40C	FMPPE3	R/W	0xFFFF.FFFF	Flash Memory Protection Program Enable 3	553

7.4 Flash Memory Register Descriptions (Flash Control Offset)

This section lists and describes the Flash Memory registers, in numerical order by address offset. Registers in this section are relative to the Flash control base address of 0x400F.D000.

Register 1: Flash Memory Address (FMA), offset 0x000

During a single word write operation, this register contains a 4-byte-aligned address and specifies where the data is written. During a write operation that uses the write buffer, this register contains a 128-byte (32-word) aligned address that specifies the start of the 32-word block to be written. During erase operations, this register contains a 1 KB-aligned CPU byte address and specifies which block is erased. Note that the alignment requirements must be met by software or the results of the operation are unpredictable.

Flash Memory Address (FMA)

Base 0x400F.D000

Offset 0x000

Type R/W, reset 0x0000.0000

	31	30	29	28	27	26	25	24	23	22	21	20	19	18	17	16
	reserved														OFFSET	
Type	RO	RO	RO	RO	RO	RO	RO	RO	RO	RO	RO	RO	RO	RO	R/W	R/W
Reset	0	0	0	0	0	0	0	0	0	0	0	0	0	0	0	0
	15	14	13	12	11	10	9	8	7	6	5	4	3	2	1	0
	OFFSET															
Type	R/W	R/W	R/W	R/W	R/W	R/W	R/W	R/W	R/W	R/W	R/W	R/W	R/W	R/W	R/W	R/W
Reset	0	0	0	0	0	0	0	0	0	0	0	0	0	0	0	0

Bit/Field	Name	Type	Reset	Description
31:18	reserved	RO	0x0	Software should not rely on the value of a reserved bit. To provide compatibility with future products, the value of a reserved bit should be preserved across a read-modify-write operation.
17:0	OFFSET	R/W	0x0	Address Offset Address offset in Flash memory where operation is performed, except for non-volatile registers (see “Non-Volatile Register Programming” on page 508 for details on values for this field).

Register 2: Flash Memory Data (FMD), offset 0x004

This register contains the data to be written during the programming cycle. This register is not used during erase cycles.

Flash Memory Data (FMD)

Base 0x400F.D000

Offset 0x004

Type R/W, reset 0x0000.0000

	31	30	29	28	27	26	25	24	23	22	21	20	19	18	17	16
	DATA															
Type	R/W	R/W	R/W	R/W	R/W	R/W	R/W	R/W	R/W	R/W	R/W	R/W	R/W	R/W	R/W	R/W
Reset	0	0	0	0	0	0	0	0	0	0	0	0	0	0	0	0
	15	14	13	12	11	10	9	8	7	6	5	4	3	2	1	0
	DATA															
Type	R/W	R/W	R/W	R/W	R/W	R/W	R/W	R/W	R/W	R/W	R/W	R/W	R/W	R/W	R/W	R/W
Reset	0	0	0	0	0	0	0	0	0	0	0	0	0	0	0	0

Bit/Field	Name	Type	Reset	Description
31:0	DATA	R/W	0x0000.0000	Data Value Data value for write operation.

Register 3: Flash Memory Control (FMC), offset 0x008

When this register is written, the Flash memory controller initiates the appropriate access cycle for the location specified by the **Flash Memory Address (FMA)** register (see page 517). If the access is a write access, the data contained in the **Flash Memory Data (FMD)** register (see page 518) is written to the specified address.

This register must be the final register written and initiates the memory operation. The four control bits in the lower byte of this register are used to initiate memory operations.

Care must be taken not to set multiple control bits as the results of such an operation are unpredictable.

Flash Memory Control (FMC)

Base 0x400F.D000

Offset 0x008

Type R/W, reset 0x0000.0000

	31	30	29	28	27	26	25	24	23	22	21	20	19	18	17	16	
	WRKEY																
Type	WO	WO	WO	WO	WO	WO	WO	WO	WO	WO	WO	WO	WO	WO	WO	WO	
Reset	0	0	0	0	0	0	0	0	0	0	0	0	0	0	0	0	
	15	14	13	12	11	10	9	8	7	6	5	4	3	2	1	0	
	reserved												COMT	MERASE	ERASE	WRITE	
Type	RO	RO	RO	RO	RO	RO	RO	RO	RO	RO	RO	RO	RO	R/W	R/W	R/W	R/W
Reset	0	0	0	0	0	0	0	0	0	0	0	0	0	0	0	0	0

Bit/Field	Name	Type	Reset	Description
31:16	WRKEY	WO	0x0000	Flash Memory Write Key This field contains a write key, which is used to minimize the incidence of accidental Flash memory writes. The value 0xA442 must be written into this field for a Flash memory write to occur. Writes to the FMC register without this <code>WRKEY</code> value are ignored. A read of this field returns the value 0.
15:4	reserved	RO	0x00	Software should not rely on the value of a reserved bit. To provide compatibility with future products, the value of a reserved bit should be preserved across a read-modify-write operation.
3	COMT	R/W	0	Commit Register Value This bit is used to commit writes to Flash-memory-resident registers and to monitor the progress of that process. Value Description 1 Set this bit to commit (write) the register value to a Flash-memory-resident register. When read, a 1 indicates that the previous commit access is not complete. 0 A write of 0 has no effect on the state of this bit. When read, a 0 indicates that the previous commit access is complete.

See "Non-Volatile Register Programming" on page 508 for more information on programming Flash-memory-resident registers.

Bit/Field	Name	Type	Reset	Description
2	MERASE	R/W	0	<p>Mass Erase Flash Memory</p> <p>This bit is used to mass erase the Flash main memory and to monitor the progress of that process.</p> <p>Value Description</p> <p>1 Set this bit to erase the Flash main memory. When read, a 1 indicates that the previous mass erase operation is not complete.</p> <p>0 A write of 0 has no effect on the state of this bit. When read, a 0 indicates that the previous mass erase operation is complete.</p> <p>For information on erase time, see “Flash Memory and EEPROM” on page 1334.</p>
1	ERASE	R/W	0	<p>Erase a Page of Flash Memory</p> <p>This bit is used to erase a page of Flash memory and to monitor the progress of that process.</p> <p>Value Description</p> <p>1 Set this bit to erase the Flash memory page specified by the contents of the FMA register. When read, a 1 indicates that the previous page erase operation is not complete.</p> <p>0 A write of 0 has no effect on the state of this bit. When read, a 0 indicates that the previous page erase operation is complete.</p> <p>For information on erase time, see “Flash Memory and EEPROM” on page 1334.</p>
0	WRITE	R/W	0	<p>Write a Word into Flash Memory</p> <p>This bit is used to write a word into Flash memory and to monitor the progress of that process.</p> <p>Value Description</p> <p>1 Set this bit to write the data stored in the FMD register into the Flash memory location specified by the contents of the FMA register. When read, a 1 indicates that the write update operation is not complete.</p> <p>0 A write of 0 has no effect on the state of this bit. When read, a 0 indicates that the previous write update operation is complete.</p> <p>For information on programming time, see “Flash Memory and EEPROM” on page 1334.</p>

Register 4: Flash Controller Raw Interrupt Status (FCRIS), offset 0x00C

This register indicates that the Flash memory controller has an interrupt condition. An interrupt is sent to the interrupt controller only if the corresponding **FCIM** register bit is set.

Flash Controller Raw Interrupt Status (FCRIS)

Base 0x400F.D000

Offset 0x00C

Type RO, reset 0x0000.0000

	31	30	29	28	27	26	25	24	23	22	21	20	19	18	17	16
	reserved															
Type	RO	RO	RO	RO	RO	RO	RO	RO	RO	RO	RO	RO	RO	RO	RO	RO
Reset	0	0	0	0	0	0	0	0	0	0	0	0	0	0	0	0
	15	14	13	12	11	10	9	8	7	6	5	4	3	2	1	0
	reserved		PROGRIS	reserved	ERRIS	INVDRIS	VOLTRIS	reserved						ERIS	PRIS	ARIS
Type	RO	RO	RO	RO	RO	RO	RO	RO	RO	RO	RO	RO	RO	RO	RO	RO
Reset	0	0	0	0	0	0	0	0	0	0	0	0	0	0	0	0

Bit/Field	Name	Type	Reset	Description
31:14	reserved	RO	0	Software should not rely on the value of a reserved bit. To provide compatibility with future products, the value of a reserved bit should be preserved across a read-modify-write operation.
13	PROGRIS	RO	0	Program Verify Error Raw Interrupt Status Value Description 1 An interrupt is pending because the verify of a PROGRAM operation failed. If this error occurs when using the Flash write buffer, software must inspect the affected words to determine where the error occurred. 0 An interrupt has not occurred. This bit is cleared by writing a 1 to the PROGMISC bit in the FCMISC register.
12	reserved	RO	0	Software should not rely on the value of a reserved bit. To provide compatibility with future products, the value of a reserved bit should be preserved across a read-modify-write operation.
11	ERRIS	RO	0	Erase Verify Error Raw Interrupt Status Value Description 1 An interrupt is pending because the verify of an ERASE operation failed. If this error occurs when using the Flash write buffer, software must inspect the affected words to determine where the error occurred. 0 An interrupt has not occurred. This bit is cleared by writing a 1 to the ERMISC bit in the FCMISC register.

Bit/Field	Name	Type	Reset	Description
10	INVDRIS	RO	0	<p>Invalid Data Raw Interrupt Status</p> <p>Value Description</p> <p>1 An interrupt is pending because a bit that was previously programmed as a 0 is now being requested to be programmed as a 1.</p> <p>0 An interrupt has not occurred.</p> <p>This bit is cleared by writing a 1 to the <code>INVMISC</code> bit in the FCMISC register.</p>
9	VOLTRIS	RO	0	<p>Pump Voltage Raw Interrupt Status</p> <p>Value Description</p> <p>1 An interrupt is pending because the regulated voltage of the pump went out of spec during the Flash operation and the operation was terminated.</p> <p>0 An interrupt has not occurred.</p> <p>This bit is cleared by writing a 1 to the <code>VOLTMISC</code> bit in the FCMISC register.</p>
8:3	reserved	RO	0	<p>Software should not rely on the value of a reserved bit. To provide compatibility with future products, the value of a reserved bit should be preserved across a read-modify-write operation.</p>
2	ERIS	RO	0	<p>EEPROM Raw Interrupt Status</p> <p>This bit provides status EEPROM operation.</p> <p>Value Description</p> <p>1 An EEPROM interrupt has occurred.</p> <p>0 An EEPROM interrupt has not occurred.</p> <p>This bit is cleared by writing a 1 to the <code>EMISC</code> bit in the FCMISC register.</p>
1	PRIS	RO	0	<p>Programming Raw Interrupt Status</p> <p>This bit provides status on programming cycles which are write or erase actions generated through the FMC or FMC2 register bits (see page 519 and page 529).</p> <p>Value Description</p> <p>1 The programming or erase cycle has completed.</p> <p>0 The programming or erase cycle has not completed.</p> <p>This status is sent to the interrupt controller when the <code>PMASK</code> bit in the FCIM register is set.</p> <p>This bit is cleared by writing a 1 to the <code>PMISC</code> bit in the FCMISC register.</p>

Bit/Field	Name	Type	Reset	Description
0	ARIS	RO	0	Access Raw Interrupt Status Value Description 1 A program or erase action was attempted on a block of Flash memory that contradicts the protection policy for that block as set in the FMPPEn registers. 0 No access has tried to improperly program or erase the Flash memory. This status is sent to the interrupt controller when the AMASK bit in the FCIM register is set. This bit is cleared by writing a 1 to the AMISC bit in the FCMISC register.

Register 5: Flash Controller Interrupt Mask (FCIM), offset 0x010

This register controls whether the Flash memory controller generates interrupts to the controller.

Flash Controller Interrupt Mask (FCIM)

Base 0x400F.D000

Offset 0x010

Type R/W, reset 0x0000.0000

	31	30	29	28	27	26	25	24	23	22	21	20	19	18	17	16
	reserved															
Type	RO	RO	RO	RO	RO	RO	RO	RO	RO	RO	RO	RO	RO	RO	RO	RO
Reset	0	0	0	0	0	0	0	0	0	0	0	0	0	0	0	0
	15	14	13	12	11	10	9	8	7	6	5	4	3	2	1	0
	reserved		PROGMASK	reserved	ERMASK	INVDMASK	VOLTMASK	reserved						EMASK	PMASK	AMASK
Type	RO	RO	R/W	RO	R/W	R/W	R/W	RO	RO	RO	RO	RO	RO	R/W	R/W	R/W
Reset	0	0	0	0	0	0	0	0	0	0	0	0	0	0	0	0

Bit/Field	Name	Type	Reset	Description						
31:14	reserved	RO	0	Software should not rely on the value of a reserved bit. To provide compatibility with future products, the value of a reserved bit should be preserved across a read-modify-write operation.						
13	PROGMASK	R/W	0	PROGVER Interrupt Mask <table border="0"> <tr> <td>Value</td> <td>Description</td> </tr> <tr> <td>1</td> <td>An interrupt is sent to the interrupt controller when the <code>PROGRIS</code> bit is set.</td> </tr> <tr> <td>0</td> <td>The <code>PROGRIS</code> interrupt is suppressed and not sent to the interrupt controller.</td> </tr> </table>	Value	Description	1	An interrupt is sent to the interrupt controller when the <code>PROGRIS</code> bit is set.	0	The <code>PROGRIS</code> interrupt is suppressed and not sent to the interrupt controller.
Value	Description									
1	An interrupt is sent to the interrupt controller when the <code>PROGRIS</code> bit is set.									
0	The <code>PROGRIS</code> interrupt is suppressed and not sent to the interrupt controller.									
12	reserved	RO	0	Software should not rely on the value of a reserved bit. To provide compatibility with future products, the value of a reserved bit should be preserved across a read-modify-write operation.						
11	ERMASK	R/W	0	ERVER Interrupt Mask <table border="0"> <tr> <td>Value</td> <td>Description</td> </tr> <tr> <td>1</td> <td>An interrupt is sent to the interrupt controller when the <code>ERRIS</code> bit is set.</td> </tr> <tr> <td>0</td> <td>The <code>ERRIS</code> interrupt is suppressed and not sent to the interrupt controller.</td> </tr> </table>	Value	Description	1	An interrupt is sent to the interrupt controller when the <code>ERRIS</code> bit is set.	0	The <code>ERRIS</code> interrupt is suppressed and not sent to the interrupt controller.
Value	Description									
1	An interrupt is sent to the interrupt controller when the <code>ERRIS</code> bit is set.									
0	The <code>ERRIS</code> interrupt is suppressed and not sent to the interrupt controller.									
10	INVDMASK	R/W	0	Invalid Data Interrupt Mask <table border="0"> <tr> <td>Value</td> <td>Description</td> </tr> <tr> <td>1</td> <td>An interrupt is sent to the interrupt controller when the <code>INVDRIS</code> bit is set.</td> </tr> <tr> <td>0</td> <td>The <code>INVDRIS</code> interrupt is suppressed and not sent to the interrupt controller.</td> </tr> </table>	Value	Description	1	An interrupt is sent to the interrupt controller when the <code>INVDRIS</code> bit is set.	0	The <code>INVDRIS</code> interrupt is suppressed and not sent to the interrupt controller.
Value	Description									
1	An interrupt is sent to the interrupt controller when the <code>INVDRIS</code> bit is set.									
0	The <code>INVDRIS</code> interrupt is suppressed and not sent to the interrupt controller.									

Bit/Field	Name	Type	Reset	Description
9	VOLTMASK	R/W	0	<p>VOLT Interrupt Mask</p> <p>Value Description</p> <p>1 An interrupt is sent to the interrupt controller when the VOLTRIS bit is set.</p> <p>0 The VOLTRIS interrupt is suppressed and not sent to the interrupt controller.</p>
8:3	reserved	RO	0	Software should not rely on the value of a reserved bit. To provide compatibility with future products, the value of a reserved bit should be preserved across a read-modify-write operation.
2	EMASK	R/W	0	<p>EEPROM Interrupt Mask</p> <p>Value Description</p> <p>1 An interrupt is sent to the interrupt controller when the ERIS bit is set.</p> <p>0 The ERIS interrupt is suppressed and not sent to the interrupt controller.</p>
1	PMASK	R/W	0	<p>Programming Interrupt Mask</p> <p>This bit controls the reporting of the programming raw interrupt status to the interrupt controller.</p> <p>Value Description</p> <p>1 An interrupt is sent to the interrupt controller when the PRIS bit is set.</p> <p>0 The PRIS interrupt is suppressed and not sent to the interrupt controller.</p>
0	AMASK	R/W	0	<p>Access Interrupt Mask</p> <p>This bit controls the reporting of the access raw interrupt status to the interrupt controller.</p> <p>Value Description</p> <p>1 An interrupt is sent to the interrupt controller when the ARIS bit is set.</p> <p>0 The ARIS interrupt is suppressed and not sent to the interrupt controller.</p>

Register 6: Flash Controller Masked Interrupt Status and Clear (FCMISC), offset 0x014

This register provides two functions. First, it reports the cause of an interrupt by indicating which interrupt source or sources are signalling the interrupt. Second, it serves as the method to clear the interrupt reporting.

Flash Controller Masked Interrupt Status and Clear (FCMISC)

Base 0x400F.D000

Offset 0x014

Type R/W1C, reset 0x0000.0000

	31	30	29	28	27	26	25	24	23	22	21	20	19	18	17	16
	reserved															
Type	RO	RO	RO	RO	RO	RO	RO	RO	RO	RO	RO	RO	RO	RO	RO	RO
Reset	0	0	0	0	0	0	0	0	0	0	0	0	0	0	0	0
	15	14	13	12	11	10	9	8	7	6	5	4	3	2	1	0
	reserved		PROGMISC	reserved	ERMISC	INVMISC	VOLTMISC	reserved						EMISC	PMISC	AMISC
Type	RO	RO	R/W1C	RO	R/W1C	R/W1C	R/W1C	RO	RO	RO	RO	RO	RO	R/W1C	R/W1C	R/W1C
Reset	0	0	0	0	0	0	0	0	0	0	0	0	0	0	0	0

Bit/Field	Name	Type	Reset	Description
31:14	reserved	RO	0	Software should not rely on the value of a reserved bit. To provide compatibility with future products, the value of a reserved bit should be preserved across a read-modify-write operation.
13	PROGMISC	R/W1C	0	PROGVER Masked Interrupt Status and Clear Value Description 1 When read, a 1 indicates that an unmasked interrupt was signaled. Writing a 1 to this bit clears <code>PROGMISC</code> and also the <code>PROGRIS</code> bit in the <code>FCRIS</code> register (see page 521). 0 When read, a 0 indicates that an interrupt has not occurred. A write of 0 has no effect on the state of this bit.
12	reserved	RO	0	Software should not rely on the value of a reserved bit. To provide compatibility with future products, the value of a reserved bit should be preserved across a read-modify-write operation.
11	ERMISC	R/W1C	0	ERVER Masked Interrupt Status and Clear Value Description 1 When read, a 1 indicates that an unmasked interrupt was signaled. Writing a 1 to this bit clears <code>ERMISC</code> and also the <code>ERRIS</code> bit in the <code>FCRIS</code> register (see page 521). 0 When read, a 0 indicates that an interrupt has not occurred. A write of 0 has no effect on the state of this bit.

Bit/Field	Name	Type	Reset	Description
10	INVDMISC	R/W1C	0	Invalid Data Masked Interrupt Status and Clear Value Description 1 When read, a 1 indicates that an unmasked interrupt was signaled. Writing a 1 to this bit clears <code>INVDMISC</code> and also the <code>INVDNIS</code> bit in the <code>FCRIS</code> register (see page 521). 0 When read, a 0 indicates that an interrupt has not occurred. A write of 0 has no effect on the state of this bit.
9	VOLTMISC	R/W1C	0	VOLT Masked Interrupt Status and Clear Value Description 1 When read, a 1 indicates that an unmasked interrupt was signaled. Writing a 1 to this bit clears <code>VOLTMISC</code> and also the <code>VOLTRIS</code> bit in the <code>FCRIS</code> register (see page 521). 0 When read, a 0 indicates that an interrupt has not occurred. A write of 0 has no effect on the state of this bit.
8:3	reserved	RO	0	Software should not rely on the value of a reserved bit. To provide compatibility with future products, the value of a reserved bit should be preserved across a read-modify-write operation.
2	EMISC	R/W1C	0	EEPROM Masked Interrupt Status and Clear Value Description 1 When read, a 1 indicates that an unmasked interrupt was signaled. Writing a 1 to this bit clears <code>EMISC</code> and also the <code>ERIS</code> bit in the <code>FCRIS</code> register (see page 521). 0 When read, a 0 indicates that an interrupt has not occurred. A write of 0 has no effect on the state of this bit.
1	PMISC	R/W1C	0	Programming Masked Interrupt Status and Clear Value Description 1 When read, a 1 indicates that an unmasked interrupt was signaled because a programming cycle completed. Writing a 1 to this bit clears <code>PMISC</code> and also the <code>PRIS</code> bit in the <code>FCRIS</code> register (see page 521). 0 When read, a 0 indicates that a programming cycle complete interrupt has not occurred. A write of 0 has no effect on the state of this bit.

Bit/Field	Name	Type	Reset	Description
0	AMISC	R/W1C	0	Access Masked Interrupt Status and Clear
				Value Description
				1 When read, a 1 indicates that an unmasked interrupt was signaled because a program or erase action was attempted on a block of Flash memory that contradicts the protection policy for that block as set in the FMPPE n registers. Writing a 1 to this bit clears AMISC and also the ARIS bit in the FCRIS register (see page 521).
				0 When read, a 0 indicates that no improper accesses have occurred. A write of 0 has no effect on the state of this bit.

Register 7: Flash Memory Control 2 (FMC2), offset 0x020

When this register is written, the Flash memory controller initiates the appropriate access cycle for the location specified by the **Flash Memory Address (FMA)** register (see page 517). If the access is a write access, the data contained in the **Flash Write Buffer (FWB)** registers is written.

This register must be the final register written as it initiates the memory operation.

Flash Memory Control 2 (FMC2)

Base 0x400F.D000

Offset 0x020

Type R/W, reset 0x0000.0000

	31	30	29	28	27	26	25	24	23	22	21	20	19	18	17	16
	WRKEY															
Type	WO	WO	WO	WO	WO	WO	WO	WO	WO	WO	WO	WO	WO	WO	WO	WO
Reset	0	0	0	0	0	0	0	0	0	0	0	0	0	0	0	0
	15	14	13	12	11	10	9	8	7	6	5	4	3	2	1	0
	reserved															WRBUF
Type	RO	RO	RO	RO	RO	RO	RO	RO	RO	RO	RO	RO	RO	RO	RO	R/W
Reset	0	0	0	0	0	0	0	0	0	0	0	0	0	0	0	0

Bit/Field	Name	Type	Reset	Description
31:16	WRKEY	WO	0x0000	Flash Memory Write Key This field contains a write key, which is used to minimize the incidence of accidental Flash memory writes. The value 0xA442 must be written into this field for a write to occur. Writes to the FMC2 register without this WRKEY value are ignored. A read of this field returns the value 0.
15:1	reserved	RO	0x000	Software should not rely on the value of a reserved bit. To provide compatibility with future products, the value of a reserved bit should be preserved across a read-modify-write operation.
0	WRBUF	R/W	0	Buffered Flash Memory Write This bit is used to start a buffered write to Flash memory.

Value Description

- 1 Set this bit to write the data stored in the **FWBn** registers to the location specified by the contents of the **FMA** register.
When read, a 1 indicates that the previous buffered Flash memory write access is not complete.
- 0 A write of 0 has no effect on the state of this bit.
When read, a 0 indicates that the previous buffered Flash memory write access is complete.

For information on programming time, see "Flash Memory and EEPROM" on page 1334.

Register 8: Flash Write Buffer Valid (FWBVAL), offset 0x030

This register provides a bitwise status of which **FWB_n** registers have been written by the processor since the last write of the Flash memory write buffer. The entries with a 1 are written on the next write of the Flash memory write buffer. This register is cleared after the write operation by hardware. A protection violation on the write operation also clears this status.

Software can program the same 32 words to various Flash memory locations by setting the **FWB_[n]** bits after they are cleared by the write operation. The next write operation then uses the same data as the previous one. In addition, if a **FWB_n** register change should not be written to Flash memory, software can clear the corresponding **FWB_[n]** bit to preserve the existing data when the next write operation occurs.

Flash Write Buffer Valid (FWBVAL)

Base 0x400F.D000
 Offset 0x030
 Type R/W, reset 0x0000.0000

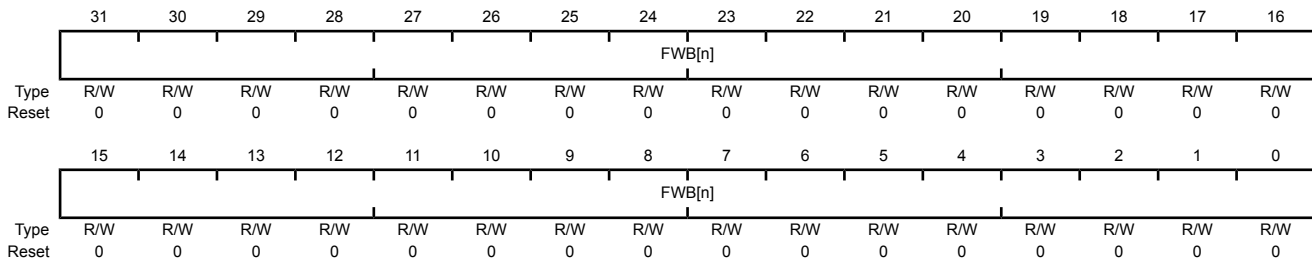

Bit/Field	Name	Type	Reset	Description
31:0	FWB[n]	R/W	0x0	Flash Memory Write Buffer

Value	Description
1	The corresponding FWB_n register has been updated since the last buffer write operation and is ready to be written to Flash memory.
0	The corresponding FWB_n register has no new data to be written.

Bit 0 corresponds to **FWB₀**, offset 0x100, and bit 31 corresponds to **FWB₃₁**, offset 0x13C.

Register 9: Flash Write Buffer n (FWBn), offset 0x100 - 0x17C

These 32 registers hold the contents of the data to be written into the Flash memory on a buffered Flash memory write operation. The offset selects one of the 32-bit registers. Only **FWBn** registers that have been updated since the preceding buffered Flash memory write operation are written into the Flash memory, so it is not necessary to write the entire bank of registers in order to write 1 or 2 words. The **FWBn** registers are written into the Flash memory with the **FWB0** register corresponding to the address contained in **FMA**. **FWB1** is written to the address **FMA+0x4** etc. Note that only data bits that are 0 result in the Flash memory being modified. A data bit that is 1 leaves the content of the Flash memory bit at its previous value.

Flash Write Buffer n (FWBn)

Base 0x400F.D000
Offset 0x100 - 0x17C
Type R/W, reset 0x0000.0000

	31	30	29	28	27	26	25	24	23	22	21	20	19	18	17	16
	DATA															
Type	R/W	R/W	R/W	R/W	R/W	R/W	R/W	R/W	R/W	R/W	R/W	R/W	R/W	R/W	R/W	R/W
Reset	0	0	0	0	0	0	0	0	0	0	0	0	0	0	0	0
	15	14	13	12	11	10	9	8	7	6	5	4	3	2	1	0
	DATA															
Type	R/W	R/W	R/W	R/W	R/W	R/W	R/W	R/W	R/W	R/W	R/W	R/W	R/W	R/W	R/W	R/W
Reset	0	0	0	0	0	0	0	0	0	0	0	0	0	0	0	0

Bit/Field	Name	Type	Reset	Description
31:0	DATA	R/W	0x0000.0000	Data Data to be written into the Flash memory.

Register 10: Flash Size (FSIZE), offset 0xFC0

This register indicates the size of the on-chip Flash memory.

Important: This register should be used to determine the size of the Flash memory that is implemented on this microcontroller. However, to support legacy software, the **DC0** register is available. A read of the **DC0** register correctly identifies legacy memory sizes. Software must use the **FSIZE** register for memory sizes that are not listed in the **DC0** register description.

Flash Size (FSIZE)

Base 0x400F.D000
 Offset 0xFC0
 Type RO, reset 0x0000.007F

	31	30	29	28	27	26	25	24	23	22	21	20	19	18	17	16
	reserved															
Type	RO	RO	RO	RO	RO	RO	RO	RO	RO	RO	RO	RO	RO	RO	RO	RO
Reset	0	0	0	0	0	0	0	0	0	0	0	0	0	0	0	0
	15	14	13	12	11	10	9	8	7	6	5	4	3	2	1	0
	SIZE															
Type	RO	RO	RO	RO	RO	RO	RO	RO	RO	RO	RO	RO	RO	RO	RO	RO
Reset	0	0	0	0	0	0	0	0	0	1	1	1	1	1	1	1

Bit/Field	Name	Type	Reset	Description
31:16	reserved	RO	0x0	Software should not rely on the value of a reserved bit. To provide compatibility with future products, the value of a reserved bit should be preserved across a read-modify-write operation.
15:0	SIZE	RO	0x7F	Flash Size Indicates the size of the on-chip Flash memory.

Value	Description
0x0003	8 KB of Flash
0x0007	16 KB of Flash
0x000F	32 KB of Flash
0x001F	64 KB of Flash
0x002F	96 KB of Flash
0x003F	128 KB of Flash
0x005F	192 KB of Flash
0x007F	256 KB of Flash

Register 11: SRAM Size (SSIZE), offset 0xFC4

This register indicates the size of the on-chip SRAM.

Important: This register should be used to determine the size of the SRAM that is implemented on this microcontroller. However, to support legacy software, the **DC0** register is available. A read of the **DC0** register correctly identifies legacy memory sizes. Software must use the **SSIZE** register for memory sizes that are not listed in the **DC0** register description.

SRAM Size (SSIZE)

Base 0x400F.D000

Offset 0xFC4

Type RO, reset 0x0000.007F

	31	30	29	28	27	26	25	24	23	22	21	20	19	18	17	16
	reserved															
Type	RO	RO	RO	RO	RO	RO	RO	RO	RO	RO	RO	RO	RO	RO	RO	RO
Reset	0	0	0	0	0	0	0	0	0	0	0	0	0	0	0	0
	15	14	13	12	11	10	9	8	7	6	5	4	3	2	1	0
	SIZE															
Type	RO	RO	RO	RO	RO	RO	RO	RO	RO	RO	RO	RO	RO	RO	RO	RO
Reset	0	0	0	0	0	0	0	0	0	1	1	1	1	1	1	1

Bit/Field	Name	Type	Reset	Description
31:16	reserved	RO	0x0	Software should not rely on the value of a reserved bit. To provide compatibility with future products, the value of a reserved bit should be preserved across a read-modify-write operation.
15:0	SIZE	RO	0x7F	SRAM Size Indicates the size of the on-chip SRAM.
	Value	Description		
	0x0007	2 KB of SRAM		
	0x000F	4 KB of SRAM		
	0x0017	6 KB of SRAM		
	0x001F	8 KB of SRAM		
	0x002F	12 KB of SRAM		
	0x003F	16 KB of SRAM		
	0x004F	20 KB of SRAM		
	0x005F	24 KB of SRAM		
	0x007F	32 KB of SRAM		

Register 12: ROM Software Map (ROMSWMAP), offset 0xFCC

This register indicates the presence of third-party software in the on-chip ROM.

Important: This register should be used to determine the presence of third-party software in the on-chip ROM on this microcontroller. However, to support legacy software, the **NVMSTAT** register is available. A read of the **TPSW** bit in the **NVMSTAT** register correctly identifies the presence of legacy third-party software. Software should use the **ROMSWMAP** register for software that is not on legacy devices.

ROM Software Map (ROMSWMAP)

Base 0x400F.D000

Offset 0xFCC

Type RO, reset 0x0000.0000

	31	30	29	28	27	26	25	24	23	22	21	20	19	18	17	16
	reserved															
Type	RO	RO	RO	RO	RO	RO	RO	RO	RO	RO	RO	RO	RO	RO	RO	RO
Reset	0	0	0	0	0	0	0	0	0	0	0	0	0	0	0	0
	15	14	13	12	11	10	9	8	7	6	5	4	3	2	1	0
	reserved															SAFERTOS
Type	RO	RO	RO	RO	RO	RO	RO	RO	RO	RO	RO	RO	RO	RO	RO	RO
Reset	0	0	0	0	0	0	0	0	0	0	0	0	0	0	0	0

Bit/Field	Name	Type	Reset	Description
31:1	reserved	RO	0x0000	Software should not rely on the value of a reserved bit. To provide compatibility with future products, the value of a reserved bit should be preserved across a read-modify-write operation.
0	SAFERTOS	RO	0x0	SafeRTOS Present
				Value Description
				0 SafeRTOS is not in the on-chip ROM.
				1 SafeRTOS is in the on-chip ROM.

7.5 EEPROM Register Descriptions (EEPROM Offset)

This section lists and describes the EEPROM registers, in numerical order by address offset. Registers in this section are relative to the EEPROM base address of 0x400A.F000.

Note that the EEPROM module clock must be enabled before the registers can be programmed (see page 334). There must be a delay of 3 system clocks after the EEPROM module clock is enabled before any EEPROM module registers are accessed. In addition, after enabling or resetting the EEPROM module, software must wait until the **WORKING** bit in the **EEDONE** register is clear before accessing any EEPROM registers.

Register 13: EEPROM Size Information (EESIZE), offset 0x000

The **EESIZE** register indicates the number of 16-word blocks and 32-bit words in the EEPROM.

EEPROM Size Information (EESIZE)

Base 0x400A.F000

Offset 0x000

Type RO, reset 0x0020.0200

	31	30	29	28	27	26	25	24	23	22	21	20	19	18	17	16
	reserved					BLKCNT										
Type	RO	RO	RO	RO	RO	RO	RO	RO	RO	RO	RO	RO	RO	RO	RO	RO
Reset	0	0	0	0	0	0	0	0	0	0	0	1	0	0	0	0
	15	14	13	12	11	10	9	8	7	6	5	4	3	2	1	0
	WORDCNT															
Type	RO	RO	RO	RO	RO	RO	RO	RO	RO	RO	RO	RO	RO	RO	RO	RO
Reset	0	0	0	0	0	0	1	0	0	0	0	0	0	0	0	0

Bit/Field	Name	Type	Reset	Description
31:27	reserved	RO	0	Software should not rely on the value of a reserved bit. To provide compatibility with future products, the value of a reserved bit should be preserved across a read-modify-write operation.
26:16	BLKCNT	RO	0x20	Number of 16-Word Blocks This value encoded in this field describes the number of 16-word blocks in the EEPROM.
15:0	WORDCNT	RO	0x200	Number of 32-Bit Words This value encoded in this field describes the number of 32-bit words in the EEPROM.

Register 14: EEPROM Current Block (EEBLOCK), offset 0x004

The **EEBLOCK** register is used to select the EEPROM block for subsequent reads, writes, and protection control. The value is a block offset into the EEPROM, such that the first block is 0, then second block is 1, etc. Each block contains 16 words. Attempts to set an invalid block causes the **BLOCK** field to be configured to 0. To verify that the intended block is being accessed, software can read the **BLOCK** field after it has been written. An invalid block can be either a non-existent block or a block that has been hidden using the **EEHIDE** register. Note that block 0 cannot be hidden.

EEPROM Current Block (EEBLOCK)

Base 0x400A.F000

Offset 0x004

Type R/W, reset 0x0000.0000

	31	30	29	28	27	26	25	24	23	22	21	20	19	18	17	16
	reserved															
Type	RO	RO	RO	RO	RO	RO	RO	RO	RO	RO	RO	RO	RO	RO	RO	RO
Reset	0	0	0	0	0	0	0	0	0	0	0	0	0	0	0	0
	15	14	13	12	11	10	9	8	7	6	5	4	3	2	1	0
	BLOCK															
Type	R/W	R/W	R/W	R/W	R/W	R/W	R/W	R/W	R/W	R/W	R/W	R/W	R/W	R/W	R/W	R/W
Reset	0	0	0	0	0	0	0	0	0	0	0	0	0	0	0	0

Bit/Field	Name	Type	Reset	Description
31:16	reserved	RO	0x00000	Software should not rely on the value of a reserved bit. To provide compatibility with future products, the value of a reserved bit should be preserved across a read-modify-write operation.
15:0	BLOCK	R/W	0x0000	<p>Current Block</p> <p>This field specifies the block in the EEPROM that is selected for subsequent accesses. Once this field is configured, the read-write registers operate against the specified block, using the EEOFFSET register to select the word within the block. Additionally, the protection and unlock registers are used for the selected block. The maximum value that can be written into this register is determined by the block count, as indicated by the EESIZE register. Attempts to write this field larger than the maximum number of blocks or to a locked block causes this field to be configured to 0.</p>

Register 15: EEPROM Current Offset (EEOFFSET), offset 0x008

The **EEOFFSET** register is used to select the EEPROM word to read or write within the block selected by the **EEBLOCK** register. The value is a word offset into the block. Because accesses to the **EERDWRINC** register change the offset, software can read the contents of this register to determine the current offset.

EEPROM Current Offset (EEOFFSET)

Base 0x400A.F000

Offset 0x008

Type R/W, reset 0x0000.0000

	31	30	29	28	27	26	25	24	23	22	21	20	19	18	17	16
	reserved															
Type	RO	RO	RO	RO	RO	RO	RO	RO	RO	RO	RO	RO	RO	RO	RO	RO
Reset	0	0	0	0	0	0	0	0	0	0	0	0	0	0	0	0
	15	14	13	12	11	10	9	8	7	6	5	4	3	2	1	0
	reserved												OFFSET			
Type	RO	RO	RO	RO	RO	RO	RO	RO	RO	RO	RO	RO	R/W	R/W	R/W	R/W
Reset	0	0	0	0	0	0	0	0	0	0	0	0	0	0	0	0

Bit/Field	Name	Type	Reset	Description
31:4	reserved	RO	0x0000.000	Software should not rely on the value of a reserved bit. To provide compatibility with future products, the value of a reserved bit should be preserved across a read-modify-write operation.
3:0	OFFSET	R/W	0x0	Current Address Offset This value is the current address specified as an offset into the block selected by the EEBLOCK register. Once configured, the read-write registers, EERDRWR and EERDWRINC , operate against that address. The offset is automatically incremented by the EERDWRINC register, with wrap around within the block, which means the offset is incremented from 15 back to 0.

Register 16: EEPROM Read-Write (EERDWR), offset 0x010

The **EERDWR** register is used to read or write the EEPROM word at the address pointed to by the **EEBLOCK** and **EEOFFSET** registers. If the protection or access rules do not permit access, the operation is handled as follows: if reading is not allowed, the value 0xFFFF.FFFF is returned in all cases; if writing is not allowed, the **EEDONE** register is configured to indicate an error.

EEPROM Read-Write (EERDWR)

Base 0x400A.F000

Offset 0x010

Type R/W, reset -

	31	30	29	28	27	26	25	24	23	22	21	20	19	18	17	16
	VALUE															
Type	R/W	R/W	R/W	R/W	R/W	R/W	R/W	R/W	R/W	R/W	R/W	R/W	R/W	R/W	R/W	R/W
Reset	-	-	-	-	-	-	-	-	-	-	-	-	-	-	-	-
	15	14	13	12	11	10	9	8	7	6	5	4	3	2	1	0
	VALUE															
Type	R/W	R/W	R/W	R/W	R/W	R/W	R/W	R/W	R/W	R/W	R/W	R/W	R/W	R/W	R/W	R/W
Reset	-	-	-	-	-	-	-	-	-	-	-	-	-	-	-	-

Bit/Field	Name	Type	Reset	Description
31:0	VALUE	R/W	-	<p>EEPROM Read or Write Data</p> <p>On a read, this field contains the value at the word pointed to by EEOFFSET. On a write, this field contains the data to be stored at the word pointed to by EEOFFSET. For writes, configuring this field starts the write process. If protection and access rules do not permit reads, all 1s are returned. If protection and access rules do not permit writes, the write fails and the EEDONE register indicates failure.</p>

Register 17: EEPROM Read-Write with Increment (EERDWRINC), offset 0x014

The **EERDWRINC** register is used to read or write the EEPROM word at the address pointed to by the **EEBLOCK** and **EEOFFSET** registers, and then increment the **OFFSET** field in the **EEOFFSET** register. If the protection or access rules do not permit access, the operation is handled as follows: if reading is not allowed, the value 0xFFFF.FFFF is returned in all cases; if writing is not allowed, the **EEDONE** register is configured to indicate an error. In all cases, the **OFFSET** field is incremented. If the last value is reached, **OFFSET** wraps around to 0 and points to the first word.

EEPROM Read-Write with Increment (EERDWRINC)

Base 0x400A.F000

Offset 0x014

Type R/W, reset -

	31	30	29	28	27	26	25	24	23	22	21	20	19	18	17	16
	VALUE															
Type	R/W	R/W	R/W	R/W	R/W	R/W	R/W	R/W	R/W	R/W	R/W	R/W	R/W	R/W	R/W	R/W
Reset	-	-	-	-	-	-	-	-	-	-	-	-	-	-	-	-
	15	14	13	12	11	10	9	8	7	6	5	4	3	2	1	0
	VALUE															
Type	R/W	R/W	R/W	R/W	R/W	R/W	R/W	R/W	R/W	R/W	R/W	R/W	R/W	R/W	R/W	R/W
Reset	-	-	-	-	-	-	-	-	-	-	-	-	-	-	-	-

Bit/Field	Name	Type	Reset	Description
31:0	VALUE	R/W	-	<p>EEPROM Read or Write Data with Increment</p> <p>On a read, this field contains the value at the word pointed to by EEOFFSET. On a write, this field contains the data to be stored at the word pointed to by EEOFFSET. For writes, configuring this field starts the write process. If protection and access rules do not permit reads, all 1s are returned. If protection and access rules do not permit writes, the write fails and the EEDONE register indicates failure.</p> <p>Regardless of error, the OFFSET field in the EEOFFSET register is incremented by 1, and the value wraps around if the last word is reached.</p>

Register 18: EEPROM Done Status (EEDONE), offset 0x018

The **EEDONE** register indicates the successful or failed completion of a write using the **EERDWR** or **EERDWRINC** register, protection set using the **EEPROT** register, password registered using the **EEPASS** register, copy buffer erase or program retry using the **EESUPP** register, or a debug mass erase using the **EEDBGME** register. The **EEDONE** register can be used with the **EEINT** register to generate an interrupt to report the status. The normal usage is to poll the **EEDONE** register or read the register after an interrupt is triggered. When the **EEDONE** bit 0 is set, then the operation is still in progress. When the **EEDONE** bit 0 is clear, then the value of **EEDONE** indicates the completion status. If **EEDONE**==0, then the write completed successfully. If **EEDONE**!=0, then an error occurred and the source of the error is given by the set bit(s). If an error occurs, corrective action may be taken as explained on page 542.

EEPROM Done Status (EEDONE)

Base 0x400A.F000

Offset 0x018

Type RO, reset 0x0000.0000

	31	30	29	28	27	26	25	24	23	22	21	20	19	18	17	16	
	reserved																
Type	RO	RO	RO	RO	RO	RO	RO	RO	RO	RO	RO	RO	RO	RO	RO	RO	
Reset	0	0	0	0	0	0	0	0	0	0	0	0	0	0	0	0	
	15	14	13	12	11	10	9	8	7	6	5	4	3	2	1	0	
	reserved							INVPL	reserved			WRBUSY	NOPERM	WKCOPY	WKERASE	reserved	WORKING
Type	RO	RO	RO	RO	RO	RO	RO	RO	RO	RO	RO	RO	RO	RO	RO	RO	
Reset	0	0	0	0	0	0	0	0	0	0	0	0	0	0	0	0	

Bit/Field	Name	Type	Reset	Description
31:9	reserved	RO	0x0000.0	Software should not rely on the value of a reserved bit. To provide compatibility with future products, the value of a reserved bit should be preserved across a read-modify-write operation.
8	INVPL	RO	0	Invalid Program Voltage Level Value Description 1 An error occurred during programming due to the voltage level dropping below the level required for EEPROM programming. This operation can be retried, however the voltage must be stabilized before retrying. 0 No error
7:6	reserved	RO	0x0	Software should not rely on the value of a reserved bit. To provide compatibility with future products, the value of a reserved bit should be preserved across a read-modify-write operation.
5	WRBUSY	RO	0	Write Busy Value Description 1 An attempt to access the EEPROM was made while a write was in progress. 0 No error

Bit/Field	Name	Type	Reset	Description
4	NOPERM	RO	0	Write Without Permission Value Description 1 An attempt was made to write without permission. This error can result because the block is locked, the write violates the programmed access protection, or when an attempt is made to write a password when the password has already been written. 0 No error
3	WKCOPY	RO	0	Working on a Copy Value Description 1 A write is in progress and is waiting for the EEPROM to copy to or from the copy buffer. 0 The EEPROM is not copying.
2	WKERASE	RO	0	Working on an Erase Value Description 1 A write is in progress and the original block is being erased after being copied. 0 The EEPROM is not erasing.
1	reserved	RO	0	Software should not rely on the value of a reserved bit. To provide compatibility with future products, the value of a reserved bit should be preserved across a read-modify-write operation.
0	WORKING	RO	0	EEPROM Working Value Description 1 The EEPROM is performing the requested operation. 0 The EEPROM is not working.

Register 19: EEPROM Support Control and Status (EESUPP), offset 0x01C

The **EESUPP** register indicates if internal operations are required because an internal copy buffer must be erased or a programming failure has occurred and the operation must be completed. These conditions are explained below as well as in more detail in the section called “Manual Copy Buffer Erase” on page 513 and the section called “Error During Programming” on page 513.

- The **EREQ** bit is set if the internal copy buffer must be erased the next time it is used because it is full. To avoid the delay of waiting for the copy buffer to be erased on the next write, it can be erased manually using this register by setting the **START** bit.
- If either **PRETRY** or **ERETRY** is set indicating that an operation must be completed, setting the **START** bit causes the operation to be performed again.

These bits are not changed by reset, so any condition that occurred before a reset is still indicated after a reset.

EEPROM Support Control and Status (EESUPP)

Base 0x400A.F000

Offset 0x01C

Type R/W, reset -

	31	30	29	28	27	26	25	24	23	22	21	20	19	18	17	16	
	reserved																
Type	RO	RO	RO	RO	RO	RO	RO	RO	RO	RO	RO	RO	RO	RO	RO	RO	
Reset	0	0	0	0	0	0	0	0	0	0	0	0	0	0	0	0	
	15	14	13	12	11	10	9	8	7	6	5	4	3	2	1	0	
	reserved													PRETRY	ERETRY	EREQ	START
Type	RO	RO	RO	RO	RO	RO	RO	RO	RO	RO	RO	RO	RO	RO	RO	R/W	
Reset	0	0	0	0	0	0	0	0	0	0	0	0	-	-	-	0	

Bit/Field	Name	Type	Reset	Description
31:4	reserved	RO	0x0000.000	Software should not rely on the value of a reserved bit. To provide compatibility with future products, the value of a reserved bit should be preserved across a read-modify-write operation.
3	PRETRY	RO	-	Programming Must Be Retried Value Description 1 Programming from a copy in either direction failed to complete and must be restarted by setting the START bit. 0 Programming has not failed.
2	ERETRY	RO	-	Erase Must Be Retried Value Description 1 Erasing failed to complete and must be restarted by setting the START bit. If the failed erase is due to the erase of a main buffer, the copy will be performed after the erase completes successfully. 0 Erasing has not failed.

Bit/Field	Name	Type	Reset	Description
1	EREQ	RO	-	Erase Required Value Description 1 An erase of the copy buffer is required. 0 The copy buffer has available space.
0	START	R/W	0	Start Erase Setting this bit starts error recovery if the PRETRY or ERETRY bit is set. If both the PRETRY and the ERETRY bits are clear, setting this bit starts erasing the copy buffer if EREQ is set. If none of the other bits in this register are set, setting this bit is ignored. After this bit is set, the WORKING bit in the EEDONE register is set and is cleared when the operation is complete. In addition, the EEINT register can be used to generate an interrupt on completion. If this bit is set while an operation is in progress, the write is ignored. The START bit is automatically cleared when the operation completes.

Register 20: EEPROM Unlock (EEUNLOCK), offset 0x020

The **EEUNLOCK** register can be used to unlock the whole EEPROM or a single block using a password. Unlocking is only required if a password is registered using the **EEPASSn** registers for the block that is selected by the **EEBLOCK** register. If block 0 has a password, it locks the remaining blocks from any type of access, but uses its own protection mechanism, for example readable, but not writable when locked. In addition, if block 0 has a password, it must be unlocked before unlocking any other block.

The **EEUNLOCK** register is written between 1 and 3 times to form the 32-bit, 64-bit, or 96-bit password registered using the **EEPASSn** registers. The value used to configure the **EEPASS0** register must always be written last. For example, for a 96-bit password, the value used to configure the **EEPASS2** register must be written first followed by the **EEPASS1** and **EEPASS0** register values. The block or the whole EEPROM can be re-locked by writing 0xFFFF.FFFF to this register.

In the event that an invalid value is written to this register, the block remains locked. The state of the EEPROM lock can be determined by reading back the **EEUNLOCK** register. If a multi-word password is set and the number of words written is incorrect, writing 0xFFFF.FFFF to this register reverts the EEPROM lock to the locked state, and the proper unlock sequence can be retried.

Note that the internal logic is balanced to prevent any electrical or time-based attack being used to find the correct password or its length.

EEPROM Unlock (EEUNLOCK)

Base 0x400A.F000

Offset 0x020

Type R/W, reset -

	31	30	29	28	27	26	25	24	23	22	21	20	19	18	17	16
	UNLOCK															
Type	R/W	R/W	R/W	R/W	R/W	R/W	R/W	R/W	R/W	R/W	R/W	R/W	R/W	R/W	R/W	R/W
Reset	-	-	-	-	-	-	-	-	-	-	-	-	-	-	-	-
	15	14	13	12	11	10	9	8	7	6	5	4	3	2	1	0
	UNLOCK															
Type	R/W	R/W	R/W	R/W	R/W	R/W	R/W	R/W	R/W	R/W	R/W	R/W	R/W	R/W	R/W	R/W
Reset	-	-	-	-	-	-	-	-	-	-	-	-	-	-	-	-

Bit/Field	Name	Type	Reset	Description
31:0	UNLOCK	R/W	-	EEPROM Unlock

Value	Description
1	The EEPROM is unlocked.
0	The EEPROM is locked.

The EEPROM is locked if the block referenced by the **EEBLOCK** register has a password registered, or if the master block (block 0) has a password. Unlocking is performed by writing the password to this register. The block or the EEPROM stays unlocked until it is locked again or until the next reset. It can be locked again by writing 0xFFFF.FFFF to this register.

Register 21: EEPROM Protection (EEPROT), offset 0x030

The **EEPROT** register is used to set or read the protection for the current block, as selected by the **EEBLOCK** register. Protection and access control is used to determine when a block's contents can be read or written.

EEPROM Protection (EEPROT)

Base 0x400A.F000

Offset 0x030

Type R/W, reset 0x0000.0000

	31	30	29	28	27	26	25	24	23	22	21	20	19	18	17	16	
	reserved																
Type	RO	RO	RO	RO	RO	RO	RO	RO	RO	RO	RO	RO	RO	RO	RO	RO	
Reset	0	0	0	0	0	0	0	0	0	0	0	0	0	0	0	0	
	15	14	13	12	11	10	9	8	7	6	5	4	3	2	1	0	
	reserved												ACC	PROT			
Type	RO	RO	RO	RO	RO	RO	RO	RO	RO	RO	RO	RO	RO	R/W	R/W	R/W	R/W
Reset	0	0	0	0	0	0	0	0	0	0	0	0	0	0	0	0	0

Bit/Field	Name	Type	Reset	Description
31:4	reserved	RO	0x0000.000	Software should not rely on the value of a reserved bit. To provide compatibility with future products, the value of a reserved bit should be preserved across a read-modify-write operation.
3	ACC	R/W	0	Access Control Value Description 1 Only supervisor code may access this block of the EEPROM. μ DMA and Debug are also prevented from accessing the EEPROM. 0 Both user and supervisor code may access this block of the EEPROM. If this bit is set for block 0, then the whole EEPROM may only be accessed by supervisor code.
2:0	PROT	R/W	0x0	Protection Control The Protection bits control what context is needed for reading and writing the block selected by the EEBLOCK register, or if block 0 is selected, all blocks. The following values are allowed: Value Description 0x0 This setting is the default. If there is no password, the block is not protected and is readable and writable. If there is a password, the block is readable, but only writable when unlocked. 0x1 If there is a password, the block is readable or writable only when unlocked. This value has no meaning when there is no password. 0x2 If there is no password, the block is readable, not writable. If there is a password, the block is readable only when unlocked, but is not writable under any conditions. 0x3 Reserved

Register 22: EEPROM Password (EEPASS0), offset 0x034**Register 23: EEPROM Password (EEPASS1), offset 0x038****Register 24: EEPROM Password (EEPASS2), offset 0x03C**

The **EEPASSn** registers are used to configure a password for a block. A password may only be set once and cannot be changed. The password may be 32-bits, 64-bits, or 96-bits. Each word of the password can be any 32-bit value other than 0xFFFF.FFFF (all 1s). To set a password, the **EEPASS0** register is written to with a value other than 0xFFFF.FFFF. When the write completes, as indicated in the **EEDONE** register, the application may choose to write to the **EEPASS1** register with a value other than 0xFFFF.FFFF. When that write completes, the application may choose to write to the **EEPASS2** register with a value other than 0xFFFF.FFFF to create a 96-bit password. The registers do not have to be written consecutively, and the **EEPASS1** and **EEPASS2** registers may be written at a later date. Based on whether 1, 2, or all 3 registers have been written, the unlock code also requires the same number of words to unlock.

Note: Once the password is written, the block is not actually locked until either a reset occurs or 0xFFFF.FFFF is written to **EEUNLOCK**.

EEPROM Password (EEPASSn)

Base 0x400A.F000

Offset 0x034

Type R/W, reset -

	31	30	29	28	27	26	25	24	23	22	21	20	19	18	17	16
	PASS															
Type	R/W	R/W	R/W	R/W	R/W	R/W	R/W	R/W	R/W	R/W	R/W	R/W	R/W	R/W	R/W	R/W
Reset	-	-	-	-	-	-	-	-	-	-	-	-	-	-	-	-
	15	14	13	12	11	10	9	8	7	6	5	4	3	2	1	0
	PASS															
Type	R/W	R/W	R/W	R/W	R/W	R/W	R/W	R/W	R/W	R/W	R/W	R/W	R/W	R/W	R/W	R/W
Reset	-	-	-	-	-	-	-	-	-	-	-	-	-	-	-	-

Bit/Field	Name	Type	Reset	Description
31:0	PASS	R/W	-	Password This register reads as 0x1 if a password is registered for this block and 0x0 if no password is registered. A write to this register if it reads as 0x0 sets the password. If an attempt is made to write to this register when it reads as 0x1, the write is ignored and the NOPERM bit in the EEDONE register is set.

Register 25: EEPROM Interrupt (EEINT), offset 0x040

The **EEINT** register is used to control whether an interrupt should be generated when a write to EEPROM completes as indicated by the **EEDONE** register value changing from 0x1 to any other value. If the **INT** bit in this register is set, the **ERIS** bit in the **Flash Controller Raw Interrupt Status (FCRIS)** register is set whenever the **EEDONE** register value changes from 0x1 as the Flash memory and the EEPROM share an interrupt vector.

EEPROM Interrupt (EEINT)

Base 0x400A.F000

Offset 0x040

Type R/W, reset 0x0000.0000

	31	30	29	28	27	26	25	24	23	22	21	20	19	18	17	16
	reserved															
Type	RO	RO	RO	RO	RO	RO	RO	RO	RO	RO	RO	RO	RO	RO	RO	RO
Reset	0	0	0	0	0	0	0	0	0	0	0	0	0	0	0	0
	15	14	13	12	11	10	9	8	7	6	5	4	3	2	1	0
	reserved															INT
Type	RO	RO	RO	RO	RO	RO	RO	RO	RO	RO	RO	RO	RO	RO	RO	R/W
Reset	0	0	0	0	0	0	0	0	0	0	0	0	0	0	0	0

Bit/Field	Name	Type	Reset	Description
31:1	reserved	RO	0x0000.000	Software should not rely on the value of a reserved bit. To provide compatibility with future products, the value of a reserved bit should be preserved across a read-modify-write operation.
0	INT	R/W	0	Interrupt Enable
				Value Description
				1 An interrupt is generated when the EEDONE register transitions from 1 to 0 or an error occurs. The EEDONE register provides status after a write to an offset location as well as a write to the password and protection bits.
				0 No interrupt is generated.

Register 26: EEPROM Block Hide (EEHIDE), offset 0x050

The **EEHIDE** register is used to hide one or more blocks other than block 0. Once hidden, the block is not accessible until the next reset. This model allows initialization code to have access to data which is not visible to the rest of the application. This register also provides for additional security in that there is no password to search for in the code or data.

EEPROM Block Hide (EEHIDE)

Base 0x400A.F000

Offset 0x050

Type R/W, reset 0x0000.0000

	31	30	29	28	27	26	25	24	23	22	21	20	19	18	17	16
	Hn															
Type	R/W	R/W	R/W	R/W	R/W	R/W	R/W	R/W	R/W	R/W	R/W	R/W	R/W	R/W	R/W	R/W
Reset	0	0	0	0	0	0	0	0	0	0	0	0	0	0	0	0
	15	14	13	12	11	10	9	8	7	6	5	4	3	2	1	0
	Hn															
Type	R/W	R/W	R/W	R/W	R/W	R/W	R/W	R/W	R/W	R/W	R/W	R/W	R/W	R/W	R/W	RO
Reset	0	0	0	0	0	0	0	0	0	0	0	0	0	0	0	0

Bit/Field	Name	Type	Reset	Description
31:1	Hn	R/W	0x0000.000	Hide Block

Value Description

- | | |
|---|---|
| 1 | The block number that corresponds to the bit number is hidden. A hidden block cannot be accessed, and the OFFSET value in the EEBLOCK register cannot be set to that block number. If an attempt is made to configure the OFFSET field to a hidden block, the EEBLOCK register is cleared.
Any attempt to clear a bit in this register that is set is ignored. |
| 0 | The corresponding block is not hidden. |

0	reserved	RO	0	Software should not rely on the value of a reserved bit. To provide compatibility with future products, the value of a reserved bit should be preserved across a read-modify-write operation.
---	----------	----	---	---

Register 27: EEPROM Debug Mass Erase (EEDBGME), offset 0x080

The **EEDBGME** register is used to mass erase the EEPROM block back to its default state from the factory. This register is intended to be used only for debug and test purposes, not in production environments. The erase takes place in such a way as to be secure. It first erases all data and then erases the protection mechanism. This register can only be written from supervisor mode by the core, and can also be written by the Stellaris debug controller when enabled. A key is used to avoid accidental use of this mechanism. Note that if a power down takes place while erasing, the mechanism should be used again to complete the operation. Powering off prematurely does not expose secured data.

To start a mass erase, the whole register must be written as 0xE37B.0001. The register reads back as 0x1 until the erase is fully completed at which time it reads as 0x0. The **EEDONE** register is set to 0x1 when the erase is started and changes to 0x0 or an error when the mass erase is complete.

Note that mass erasing the EEPROM block means that the wear-leveling counters are also reset to the factory default.

EEPROM Debug Mass Erase (EEDBGME)

Base 0x400A.F000

Offset 0x080

Type R/W, reset 0x0000.0000

	31	30	29	28	27	26	25	24	23	22	21	20	19	18	17	16
	KEY															
Type	WO	WO	WO	WO	WO	WO	WO	WO	WO	WO	WO	WO	WO	WO	WO	WO
Reset	0	0	0	0	0	0	0	0	0	0	0	0	0	0	0	0
	15	14	13	12	11	10	9	8	7	6	5	4	3	2	1	0
	reserved															ME
Type	RO	RO	RO	RO	RO	RO	RO	RO	RO	RO	RO	RO	RO	RO	RO	R/W
Reset	0	0	0	0	0	0	0	0	0	0	0	0	0	0	0	0

Bit/Field	Name	Type	Reset	Description
31:16	KEY	WO	0x0000	Erase Key This field must be written with 0xE37B for the ME field to be effective.
15:1	reserved	RO	0x000	Software should not rely on the value of a reserved bit. To provide compatibility with future products, the value of a reserved bit should be preserved across a read-modify-write operation.
0	ME	R/W	0	Mass Erase Value Description 1 When written as a 1, the EEPROM is mass erased. This bit continues to read as 1 until the EEPROM is fully erased. 0 No action.

Register 28: EEPROM Peripheral Properties (EEPROMPP), offset 0xFC0

The **EEPROMPP** register indicates the size of the EEPROM for this part.

EEPROM Peripheral Properties (EEPROMPP)

Base 0x400A.F000

Offset 0xFC0

Type RO, reset 0x0000.001F

	31	30	29	28	27	26	25	24	23	22	21	20	19	18	17	16
	reserved															
Type	RO	RO	RO	RO	RO	RO	RO	RO	RO	RO	RO	RO	RO	RO	RO	RO
Reset	0	0	0	0	0	0	0	0	0	0	0	0	0	0	0	0
	15	14	13	12	11	10	9	8	7	6	5	4	3	2	1	0
	reserved												SIZE			
Type	RO	RO	RO	RO	RO	RO	RO	RO	RO	RO	RO	RO	RO	RO	RO	RO
Reset	0	0	0	0	0	0	0	0	0	0	0	0	1	1	1	1

Bit/Field	Name	Type	Reset	Description
31:5	reserved	RO	0x0	Software should not rely on the value of a reserved bit. To provide compatibility with future products, the value of a reserved bit should be preserved across a read-modify-write operation.
4:0	SIZE	RO	0x1F	2-KB EEPROM Size

7.6 Memory Register Descriptions (System Control Offset)

The remainder of this section lists and describes the registers that reside in the System Control address space, in numerical order by address offset. Registers in this section are relative to the System Control base address of 0x400F.E000.

Register 29: ROM Control (RMCTL), offset 0x0F0

This register provides control of the ROM controller state. This register offset is relative to the System Control base address of 0x400F.E000.

At reset, the following sequence is performed:

1. The **BOOTCFG** register is read. If the **EN** bit is clear, the ROM Boot Loader is executed.
2. In the ROM Boot Loader, the status of the specified GPIO pin is compared with the specified polarity. If the status matches the specified polarity, the ROM is mapped to address 0x0000.0000 and execution continues out of the ROM Boot Loader.
3. If the **EN** bit is set or the status doesn't match the specified polarity, the data at address 0x0000.0004 is read, and if the data at this address is 0xFFFF.FFFF, the ROM is mapped to address 0x0000.0000 and execution continues out of the ROM Boot Loader.
4. If there is data at address 0x0000.0004 that is not 0xFFFF.FFFF, the stack pointer (**SP**) is loaded from Flash memory at address 0x0000.0000 and the program counter (**PC**) is loaded from address 0x0000.0004. The user application begins executing.

ROM Control (RMCTL)

Base 0x400F.E000

Offset 0x0F0

Type R/W1C, reset -

	31	30	29	28	27	26	25	24	23	22	21	20	19	18	17	16
	reserved															
Type	RO	RO	RO	RO	RO	RO	RO	RO	RO	RO	RO	RO	RO	RO	RO	RO
Reset	0	0	0	0	0	0	0	0	0	0	0	0	0	0	0	0
	15	14	13	12	11	10	9	8	7	6	5	4	3	2	1	0
	reserved															BA
Type	RO	RO	RO	RO	RO	RO	RO	RO	RO	RO	RO	RO	RO	RO	RO	R/W1C
Reset	0	0	0	0	0	0	0	0	0	0	0	0	0	0	0	1

Bit/Field	Name	Type	Reset	Description
31:1	reserved	RO	0x0000.000	Software should not rely on the value of a reserved bit. To provide compatibility with future products, the value of a reserved bit should be preserved across a read-modify-write operation.

0	BA	R/W1C	1	Boot Alias
---	----	-------	---	------------

Value	Description
1	The microcontroller's ROM appears at address 0x0.
0	The Flash memory is at address 0x0.

This bit is cleared by writing a 1 to this bit position.

Register 30: Flash Memory Protection Read Enable 0 (FMPRE0), offset 0x130 and 0x200

Register 31: Flash Memory Protection Read Enable 1 (FMPRE1), offset 0x204

Register 32: Flash Memory Protection Read Enable 2 (FMPRE2), offset 0x208

Register 33: Flash Memory Protection Read Enable 3 (FMPRE3), offset 0x20C

Note: The **FMPRE0** register is aliased for backwards compatibility.

Note: Offset is relative to System Control base address of 0x400F.E000.

This register stores the read-only protection bits for each 2-KB flash block (**FMPPEn** stores the execute-only bits).

This register is loaded during the power-on reset sequence. The factory settings for the **FMPREn** and **FMPPEn** registers are a value of 1 for all implemented 2-KB blocks. This achieves a policy of open access and programmability. The register bits may be changed by writing the specific register bit. However, this register is R/W0; the user can only change the protection bit from a 1 to a 0 (and may NOT change a 0 to a 1). The changes are not permanent until the register is committed (saved), at which point the bit change is permanent. If a bit is changed from a 1 to a 0 and not committed, it may be restored by executing a power-on reset sequence. The reset value shown only applies to power-on reset; any other type of reset does not affect this register. Once committed, the only way to restore the factory default value of this register is to perform the sequence detailed in "Recovering a "Locked" Microcontroller" on page 206.

Each **FMPREn** register controls a 64-k block of Flash. For additional information, see the "Flash Memory Protection" section.

- **FMPRE0:** 0 to 64 KB
- **FMPRE1:** 65 to 128 KB
- **FMPRE2:** 129 to 192 KB
- **FMPRE3:** 193 to 256 KB

Flash Memory Protection Read Enable n (FMPREn)

Base 0x400F.E000
 Offset 0x130 and 0x200
 Type R/W, reset 0xFFFF.FFFF

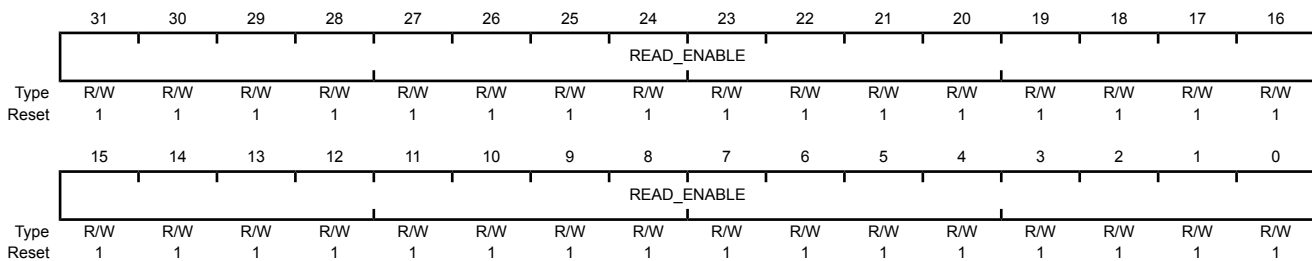

Bit/Field	Name	Type	Reset	Description
31:0	READ_ENABLE	R/W	0xFFFF.FFFF	Flash Read Enable Each bit configures a 2-KB flash block to be read only. The policies may be combined as shown in the table "Flash Protection Policy Combinations".

Register 34: Flash Memory Protection Program Enable 0 (FMPPE0), offset 0x134 and 0x400

Register 35: Flash Memory Protection Program Enable 1 (FMPPE1), offset 0x404

Register 36: Flash Memory Protection Program Enable 2 (FMPPE2), offset 0x408

Register 37: Flash Memory Protection Program Enable 3 (FMPPE3), offset 0x40C

Note: The **FMPPE0** register is aliased for backwards compatibility.

Note: Offset is relative to System Control base address of 0x400FE000.

This register stores the execute-only protection bits for each 2-KB flash block (**FMPREn** stores the read-only protection bits).

This register is loaded during the power-on reset sequence. The factory settings for the **FMPREn** and **FMPPEn** registers are a value of 1 for all implemented banks. This achieves a policy of open access and programmability. The register bits may be changed by writing the specific register bit. However, this register is R/W0; the user can only change the protection bit from a 1 to a 0 (and may NOT change a 0 to a 1). The changes are not permanent until the register is committed (saved), at which point the bit change is permanent. If a bit is changed from a 1 to a 0 and not committed, it may be restored by executing a power-on reset sequence. The reset value shown only applies to power-on reset; any other type of reset does not affect this register. Once committed, the only way to restore the factory default value of this register is to perform the sequence detailed in "Recovering a "Locked" Microcontroller" on page 206. For additional information, see the "Flash Memory Protection" section.

Each **FMPPEn** register controls a 64-k block of Flash. For additional information, see the "Flash Memory Protection" section.

- **FMPPE0:** 0 to 64 KB
- **FMPPE1:** 65 to 128 KB
- **FMPPE2:** 129 to 192 KB
- **FMPPE3:** 193 to 256 KB

Flash Memory Protection Program Enable n (FMPPEn)

Base 0x400F.E000
Offset 0x134 and 0x400
Type R/W, reset 0xFFFF.FFFF

	31	30	29	28	27	26	25	24	23	22	21	20	19	18	17	16
	PROG_ENABLE															
Type	R/W	R/W	R/W	R/W	R/W	R/W	R/W	R/W	R/W	R/W	R/W	R/W	R/W	R/W	R/W	R/W
Reset	1	1	1	1	1	1	1	1	1	1	1	1	1	1	1	1
	15	14	13	12	11	10	9	8	7	6	5	4	3	2	1	0
	PROG_ENABLE															
Type	R/W	R/W	R/W	R/W	R/W	R/W	R/W	R/W	R/W	R/W	R/W	R/W	R/W	R/W	R/W	R/W
Reset	1	1	1	1	1	1	1	1	1	1	1	1	1	1	1	1

Bit/Field	Name	Type	Reset	Description
31:0	PROG_ENABLE	R/W	0xFFFF.FFFF	Flash Programming Enable Each bit configures a 2-KB flash block to be execute only. The policies may be combined as shown in the table "Flash Protection Policy Combinations".

Register 38: Boot Configuration (BOOTCFG), offset 0x1D0

Note: Offset is relative to System Control base address of 0x400F.E000.

This register is not written directly, but instead uses the **FMD** register as explained in “Non-Volatile Register Programming” on page 508. This register provides configuration of a GPIO pin to enable the ROM Boot Loader as well as a write-once mechanism to disable external debugger access to the device. At reset, the user has the opportunity to direct the core to execute the ROM Boot Loader or the application in Flash memory by using any GPIO signal from Ports A-Q as configured by the bits in this register. At reset, the following sequence is performed:

1. The **BOOTCFG** register is read. If the **EN** bit is clear, the ROM Boot Loader is executed.
2. In the ROM Boot Loader, the status of the specified GPIO pin is compared with the specified polarity. If the status matches the specified polarity, the ROM is mapped to address 0x0000.0000 and execution continues out of the ROM Boot Loader.
3. If the **EN** bit is set or the status doesn't match the specified polarity, the data at address 0x0000.0004 is read, and if the data at this address is 0xFFFF.FFFF, the ROM is mapped to address 0x0000.0000 and execution continues out of the ROM Boot Loader.
4. If there is data at address 0x0000.0004 that is not 0xFFFF.FFFF, the stack pointer (**SP**) is loaded from Flash memory at address 0x0000.0000 and the program counter (**PC**) is loaded from address 0x0000.0004. The user application begins executing.

The **DBG0** bit is cleared by the factory and the **DBG1** bit is set, which enables external debuggers. Clearing the **DBG1** bit disables any external debugger access to the device, starting with the next power-up cycle of the device. The **NW** bit indicates that bits in the register can be changed from 1 to 0. Software can clear the **NW** bit to prevent further changes to the bits in this register.

By committing the register values using the **COMT** bit in the **FMC** register, the register contents become non-volatile and are therefore retained following power cycling. Prior to being committed, bits can only be changed from 1 to 0. The reset value shown only applies to power-on reset when the register is not yet committed; any other type of reset does not affect this register. Once committed, the register retains its value through power-on reset. Once committed, the only way to restore the factory default value of this register is to perform the sequence detailed in “Recovering a “Locked” Microcontroller” on page 206.

Boot Configuration (BOOTCFG)

Base 0x400F.E000
Offset 0x1D0
Type RO, reset 0xFFFF.FFFE

	31	30	29	28	27	26	25	24	23	22	21	20	19	18	17	16
	NW	reserved														
Type	RO	RO	RO	RO	RO	RO	RO	RO	RO	RO	RO	RO	RO	RO	RO	RO
Reset	1	1	1	1	1	1	1	1	1	1	1	1	1	1	1	1
	15	14	13	12	11	10	9	8	7	6	5	4	3	2	1	0
	PORT			PIN			POL	EN	reserved						DBG1	DBG0
Type	RO	RO	RO	RO	RO	RO	RO	RO	RO	RO	RO	RO	RO	RO	RO	RO
Reset	1	1	1	1	1	1	1	1	1	1	1	1	1	1	1	0

Bit/Field	Name	Type	Reset	Description																		
31	NW	RO	1	<p>Not Written</p> <p>When set, this bit indicates that the values in this register can be changed from 1 to 0. When clear, this bit specifies that the contents of this register cannot be changed.</p>																		
30:16	reserved	RO	0xFFFF	Software should not rely on the value of a reserved bit. To provide compatibility with future products, the value of a reserved bit should be preserved across a read-modify-write operation.																		
15:13	PORT	RO	0x7	<p>Boot GPIO Port</p> <p>This field selects the port of the GPIO port pin that enables the ROM boot loader at reset.</p> <table border="1"> <thead> <tr> <th>Value</th> <th>Description</th> </tr> </thead> <tbody> <tr><td>0x0</td><td>Port A</td></tr> <tr><td>0x1</td><td>Port B</td></tr> <tr><td>0x2</td><td>Port C</td></tr> <tr><td>0x3</td><td>Port D</td></tr> <tr><td>0x4</td><td>Port E</td></tr> <tr><td>0x5</td><td>Port F</td></tr> <tr><td>0x6</td><td>Port G</td></tr> <tr><td>0x7</td><td>Port H</td></tr> </tbody> </table>	Value	Description	0x0	Port A	0x1	Port B	0x2	Port C	0x3	Port D	0x4	Port E	0x5	Port F	0x6	Port G	0x7	Port H
Value	Description																					
0x0	Port A																					
0x1	Port B																					
0x2	Port C																					
0x3	Port D																					
0x4	Port E																					
0x5	Port F																					
0x6	Port G																					
0x7	Port H																					
12:10	PIN	RO	0x7	<p>Boot GPIO Pin</p> <p>This field selects the pin number of the GPIO port pin that enables the ROM boot loader at reset.</p> <table border="1"> <thead> <tr> <th>Value</th> <th>Description</th> </tr> </thead> <tbody> <tr><td>0x0</td><td>Pin 0</td></tr> <tr><td>0x1</td><td>Pin 1</td></tr> <tr><td>0x2</td><td>Pin 2</td></tr> <tr><td>0x3</td><td>Pin 3</td></tr> <tr><td>0x4</td><td>Pin 4</td></tr> <tr><td>0x5</td><td>Pin 5</td></tr> <tr><td>0x6</td><td>Pin 6</td></tr> <tr><td>0x7</td><td>Pin 7</td></tr> </tbody> </table>	Value	Description	0x0	Pin 0	0x1	Pin 1	0x2	Pin 2	0x3	Pin 3	0x4	Pin 4	0x5	Pin 5	0x6	Pin 6	0x7	Pin 7
Value	Description																					
0x0	Pin 0																					
0x1	Pin 1																					
0x2	Pin 2																					
0x3	Pin 3																					
0x4	Pin 4																					
0x5	Pin 5																					
0x6	Pin 6																					
0x7	Pin 7																					
9	POL	RO	1	<p>Boot GPIO Polarity</p> <p>When set, this bit selects a high level for the GPIO port pin to enable the ROM boot loader at reset. When clear, this bit selects a low level for the GPIO port pin.</p>																		
8	EN	RO	1	<p>Boot GPIO Enable</p> <p>Clearing this bit enables the use of a GPIO pin to enable the ROM Boot Loader at reset. When this bit is set, the contents of address 0x0000.0004 are checked to see if the Flash memory has been programmed. If the contents are not 0xFFFF.FFFF, the core executes out of Flash memory. If the Flash has not been programmed, the core executes out of ROM.</p>																		

Bit/Field	Name	Type	Reset	Description
7:2	reserved	RO	0x3F	Software should not rely on the value of a reserved bit. To provide compatibility with future products, the value of a reserved bit should be preserved across a read-modify-write operation.
1	DBG1	RO	1	Debug Control 1 The DBG1 bit must be 1 and DBG0 must be 0 for debug to be available.
0	DBG0	RO	0	Debug Control 0 The DBG1 bit must be 1 and DBG0 must be 0 for debug to be available.

Register 39: User Register 0 (USER_REG0), offset 0x1E0

Register 40: User Register 1 (USER_REG1), offset 0x1E4

Register 41: User Register 2 (USER_REG2), offset 0x1E8

Register 42: User Register 3 (USER_REG3), offset 0x1EC

Note: Offset is relative to System Control base address of 0x400F.E000.

These registers each provide 32 bits of user-defined data that is non-volatile. Bits can only be changed from 1 to 0. The reset value shown only applies to power-on reset when the register is not yet committed; any other type of reset does not affect this register. Once committed, the register retains its value through power-on reset. Once committed, the only way to restore the factory default value of this register is to perform the sequence detailed in “Recovering a “Locked” Microcontroller” on page 206.

User Register n (USER_REGn)

Base 0x400F.E000
 Offset 0x1E0
 Type R/W, reset 0xFFFF.FFFF

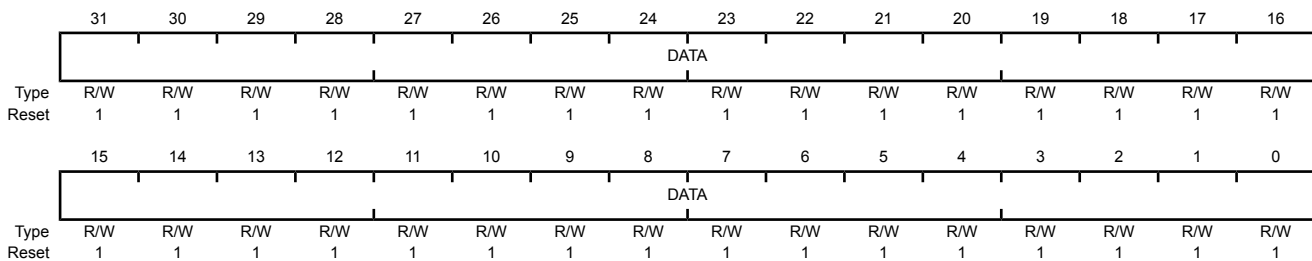

Bit/Field	Name	Type	Reset	Description
31:0	DATA	R/W	0xFFFF.FFFF	User Data Contains the user data value. This field is initialized to all 1s and once committed, retains its value through power-on reset.

8 Micro Direct Memory Access (μDMA)

The LM4F231H5QR microcontroller includes a Direct Memory Access (DMA) controller, known as micro-DMA (μDMA). The μDMA controller provides a way to offload data transfer tasks from the Cortex™-M4F processor, allowing for more efficient use of the processor and the available bus bandwidth. The μDMA controller can perform transfers between memory and peripherals. It has dedicated channels for each supported on-chip module and can be programmed to automatically perform transfers between peripherals and memory as the peripheral is ready to transfer more data. The μDMA controller provides the following features:

- ARM® PrimeCell® 32-channel configurable μDMA controller
- Support for memory-to-memory, memory-to-peripheral, and peripheral-to-memory in multiple transfer modes
 - Basic for simple transfer scenarios
 - Ping-pong for continuous data flow
 - Scatter-gather for a programmable list of arbitrary transfers initiated from a single request
- Highly flexible and configurable channel operation
 - Independently configured and operated channels
 - Dedicated channels for supported on-chip modules
 - Flexible channel assignments
 - One channel each for receive and transmit path for bidirectional modules
 - Dedicated channel for software-initiated transfers
 - Per-channel configurable priority scheme
 - Optional software-initiated requests for any channel
- Two levels of priority
- Design optimizations for improved bus access performance between μDMA controller and the processor core
 - μDMA controller access is subordinate to core access
 - RAM striping
 - Peripheral bus segmentation
- Data sizes of 8, 16, and 32 bits
- Transfer size is programmable in binary steps from 1 to 1024
- Source and destination address increment size of byte, half-word, word, or no increment
- Maskable peripheral requests

- Interrupt on transfer completion, with a separate interrupt per channel

8.1 Block Diagram

Figure 8-1. μ DMA Block Diagram

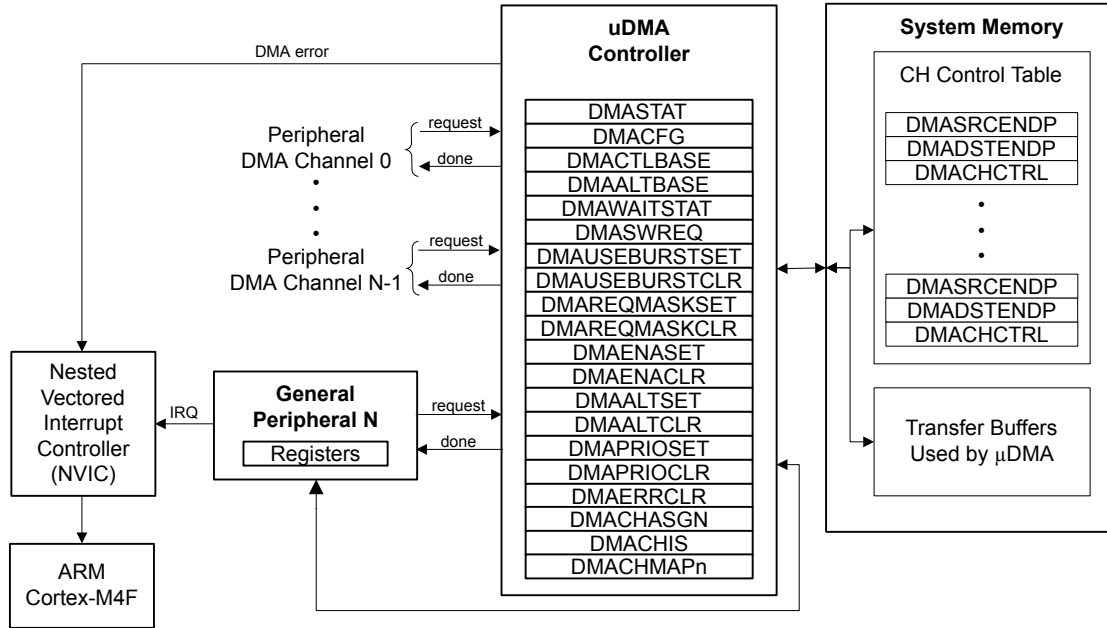

8.2 Functional Description

The μ DMA controller is a flexible and highly configurable DMA controller designed to work efficiently with the microcontroller's Cortex-M4F processor core. It supports multiple data sizes and address increment schemes, multiple levels of priority among DMA channels, and several transfer modes to allow for sophisticated programmed data transfers. The μ DMA controller's usage of the bus is always subordinate to the processor core, so it never holds up a bus transaction by the processor. Because the μ DMA controller is only using otherwise-idle bus cycles, the data transfer bandwidth it provides is essentially free, with no impact on the rest of the system. The bus architecture has been optimized to greatly enhance the ability of the processor core and the μ DMA controller to efficiently share the on-chip bus, thus improving performance. The optimizations include RAM striping and peripheral bus segmentation, which in many cases allow both the processor core and the μ DMA controller to access the bus and perform simultaneous data transfers.

The μ DMA controller can transfer data to and from the on-chip SRAM. However, because the Flash memory and ROM are located on a separate internal bus, it is not possible to transfer data from the Flash memory or ROM with the μ DMA controller.

Each peripheral function that is supported has a dedicated channel on the μ DMA controller that can be configured independently. The μ DMA controller implements a unique configuration method using channel control structures that are maintained in system memory by the processor. While simple transfer modes are supported, it is also possible to build up sophisticated "task" lists in memory that allow the μ DMA controller to perform arbitrary-sized transfers to and from arbitrary locations as part of a single transfer request. The μ DMA controller also supports the use of ping-pong buffering to accommodate constant streaming of data to or from a peripheral.

Each channel also has a configurable arbitration size. The arbitration size is the number of items that are transferred in a burst before the μ DMA controller re-arbitrates for channel priority. Using the arbitration size, it is possible to control exactly how many items are transferred to or from a peripheral each time it makes a μ DMA service request.

8.2.1 Channel Assignments

Each DMA channel has up to five possible assignments which are selected using the **DMA Channel Map Select n (DMACHMAPn)** registers with 4-bit assignment fields for each μ DMA channel.

Table 8-1 on page 561 shows the μ DMA channel mapping. The Enc. column shows the encoding for the respective **DMACHMAPn** bit field. Encodings 0x5 - 0xF are all reserved. To support legacy software which uses the **DMA Channel Assignment (DMACHASGN)** register, Enc. 0 is equivalent to a **DMACHASGN** bit being clear, and Enc. 1 is equivalent to a **DMACHASGN** bit being set. If the **DMACHASGN** register is read, bit fields return 0 if the corresponding **DMACHMAPn** register field value are equal to 0, otherwise they return 1 if the corresponding **DMACHMAPn** register field values are not equal to 0. The Type indication in the table indicates if a particular peripheral uses a single request (S), burst request (B) or either (SB).

Note: Channels noted in the table as "Available for software" may be assigned to peripherals in the future. However, they are currently available for software use. Channel 30 is dedicated for software use.

The USB endpoints mapped to μ DMA channels 0-3 can be changed with the **USBDMASEL** register (see page 1171).

Table 8-1. μ DMA Channel Assignments

Enc.	0		1		2		3		4	
Ch #	Peripheral	Type	Peripheral	Type	Peripheral	Type	Peripheral	Type	Peripheral	Type
0	USB0 EP1 RX	SB	UART2 RX	SB	Software	B	GPTimer 4A	B	Software	B
1	USB0 EP1 TX	B	UART2 TX	SB	Software	B	GPTimer 4B	B	Software	B
2	USB0 EP2 RX	B	GPTimer 3A	B	Software	B	Software	B	Software	B
3	USB0 EP2 TX	B	GPTimer 3B	B	Software	B	Software	B	Software	B
4	USB0 EP3 RX	B	GPTimer 2A	B	Software	B	GPIO A	B	Software	B
5	USB0 EP3 TX	B	GPTimer 2B	B	Software	B	GPIO B	B	Software	B
6	Software	B	GPTimer 2A	B	UART5 RX	SB	GPIO C	B	Software	B
7	Software	B	GPTimer 2B	B	UART5 TX	SB	GPIO D	B	Software	B
8	UART0 RX	SB	UART1 RX	SB	Software	B	GPTimer 5A	B	Software	B
9	UART0 TX	SB	UART1 TX	SB	Software	B	GPTimer 5B	B	Software	B
10	SSI0 RX	SB	SSI1 RX	SB	UART6 RX	SB	GPTimer 6A	B	Software	B
11	SSI0 TX	SB	SSI1 TX	SB	UART6 TX	SB	GPTimer 6B	B	Software	B
12	Software	B	UART2 RX	SB	SSI2 RX	SB	GPTimer 7A	B	Software	B
13	Software	B	UART2 TX	SB	SSI2 TX	SB	GPTimer 7B	B	Software	B
14	ADC0 SS0	B	GPTimer 2A	B	SSI3 RX	SB	GPIO E	B	Software	B
15	ADC0 SS1	B	GPTimer 2B	B	SSI3 TX	SB	GPIO F	B	Software	B
16	ADC0 SS2	B	Software	B	UART3 RX	SB	GPTimer 8A	B	Software	B
17	ADC0 SS3	B	Software	B	UART3 TX	SB	GPTimer 8B	B	Software	B
18	GPTimer 0A	B	GPTimer 1A	B	UART4 RX	SB	GPIO B	B	Software	B
19	GPTimer 0B	B	GPTimer 1B	B	UART4 TX	SB	GPIO G	B	Software	B
20	GPTimer 1A	B	Software	B	UART7 RX	SB	Software	B	Software	B

Table 8-1. μ DMA Channel Assignments (*continued*)

Enc.	0		1		2		3		4	
Ch #	Peripheral	Type	Peripheral	Type	Peripheral	Type	Peripheral	Type	Peripheral	Type
21	GPTimer 1B	B	Software	B	UART7 TX	SB	Software	B	Software	B
22	UART1 RX	SB	Software	B	Software	B	Software	B	Software	B
23	UART1 TX	SB	Software	B	Software	B	Software	B	Software	B
24	SSI1 RX	SB	ADC1 SS0	B	Software	B	GPTimer 9A	B	Software	B
25	SSI1 TX	SB	ADC1 SS1	B	Software	B	GPTimer 9B	B	Software	B
26	Software	B	ADC1 SS2	B	Software	B	GPTimer 10A	B	Software	B
27	Software	B	ADC1 SS3	B	Software	B	GPTimer 10B	B	Software	B
28	Software	B	Software	B	Software	B	GPTimer 11A	B	Software	B
29	Software	B	Software	B	Software	B	GPTimer 11B	B	Software	B
30	Software	B	Software	B	Software	B	Software	B	Software	B
31	Reserved	B	Reserved	B	Reserved	B	Reserved	B	Reserved	B

8.2.2 Priority

The μ DMA controller assigns priority to each channel based on the channel number and the priority level bit for the channel. Channel number 0 has the highest priority and as the channel number increases, the priority of a channel decreases. Each channel has a priority level bit to provide two levels of priority: default priority and high priority. If the priority level bit is set, then that channel has higher priority than all other channels at default priority. If multiple channels are set for high priority, then the channel number is used to determine relative priority among all the high priority channels.

The priority bit for a channel can be set using the **DMA Channel Priority Set (DMAPRIOSET)** register and cleared with the **DMA Channel Priority Clear (DMAPRIOCLR)** register.

8.2.3 Arbitration Size

When a μ DMA channel requests a transfer, the μ DMA controller arbitrates among all the channels making a request and services the μ DMA channel with the highest priority. Once a transfer begins, it continues for a selectable number of transfers before re-arbitrating among the requesting channels again. The arbitration size can be configured for each channel, ranging from 1 to 1024 item transfers. After the μ DMA controller transfers the number of items specified by the arbitration size, it then checks among all the channels making a request and services the channel with the highest priority.

If a lower priority μ DMA channel uses a large arbitration size, the latency for higher priority channels is increased because the μ DMA controller completes the lower priority burst before checking for higher priority requests. Therefore, lower priority channels should not use a large arbitration size for best response on high priority channels.

The arbitration size can also be thought of as a burst size. It is the maximum number of items that are transferred at any one time in a burst. Here, the term arbitration refers to determination of μ DMA channel priority, not arbitration for the bus. When the μ DMA controller arbitrates for the bus, the processor always takes priority. Furthermore, the μ DMA controller is held off whenever the processor must perform a bus transaction on the same bus, even in the middle of a burst transfer.

8.2.4 Request Types

The μ DMA controller responds to two types of requests from a peripheral: single or burst. Each peripheral may support either or both types of requests. A single request means that the peripheral

is ready to transfer one item, while a burst request means that the peripheral is ready to transfer multiple items.

The μ DMA controller responds differently depending on whether the peripheral is making a single request or a burst request. If both are asserted, and the μ DMA channel has been set up for a burst transfer, then the burst request takes precedence. See Table 8-2 on page 563, which shows how each peripheral supports the two request types.

Table 8-2. Request Type Support

Peripheral	Single Request Signal	Burst Request Signal
ADC	None	Sequencer \overline{IE} bit
General-Purpose Timer	None	Trigger event
GPIO	Raw interrupt pulse	None
SSI TX	TX FIFO Not Full	TX FIFO Level (fixed at 4)
SSI RX	RX FIFO Not Empty	RX FIFO Level (fixed at 4)
UART TX	TX FIFO Not Full	TX FIFO Level (configurable)
UART RX	RX FIFO Not Empty	RX FIFO Level (configurable)
USB TX	None	FIFO TXRDY
USB RX	None	FIFO RXRDY

8.2.4.1 Single Request

When a single request is detected, and not a burst request, the μ DMA controller transfers one item and then stops to wait for another request.

8.2.4.2 Burst Request

When a burst request is detected, the μ DMA controller transfers the number of items that is the lesser of the arbitration size or the number of items remaining in the transfer. Therefore, the arbitration size should be the same as the number of data items that the peripheral can accommodate when making a burst request. For example, the UART generates a burst request based on the FIFO trigger level. In this case, the arbitration size should be set to the amount of data that the FIFO can transfer when the trigger level is reached. A burst transfer runs to completion once it is started, and cannot be interrupted, even by a higher priority channel. Burst transfers complete in a shorter time than the same number of non-burst transfers.

It may be desirable to use only burst transfers and not allow single transfers. For example, perhaps the nature of the data is such that it only makes sense when transferred together as a single unit rather than one piece at a time. The single request can be disabled by using the **DMA Channel Useburst Set (DMAUSEBURSTSET)** register. By setting the bit for a channel in this register, the μ DMA controller only responds to burst requests for that channel.

8.2.5 Channel Configuration

The μ DMA controller uses an area of system memory to store a set of channel control structures in a table. The control table may have one or two entries for each μ DMA channel. Each entry in the table structure contains source and destination pointers, transfer size, and transfer mode. The control table can be located anywhere in system memory, but it must be contiguous and aligned on a 1024-byte boundary.

Table 8-3 on page 564 shows the layout in memory of the channel control table. Each channel may have one or two control structures in the control table: a primary control structure and an optional alternate control structure. The table is organized so that all of the primary entries are in the first

half of the table, and all the alternate structures are in the second half of the table. The primary entry is used for simple transfer modes where transfers can be reconfigured and restarted after each transfer is complete. In this case, the alternate control structures are not used and therefore only the first half of the table must be allocated in memory; the second half of the control table is not necessary, and that memory can be used for something else. If a more complex transfer mode is used such as ping-pong or scatter-gather, then the alternate control structure is also used and memory space should be allocated for the entire table.

Any unused memory in the control table may be used by the application. This includes the control structures for any channels that are unused by the application as well as the unused control word for each channel.

Table 8-3. Control Structure Memory Map

Offset	Channel
0x0	0, Primary
0x10	1, Primary
...	...
0x1F0	31, Primary
0x200	0, Alternate
0x210	1, Alternate
...	...
0x3F0	31, Alternate

Table 8-4 shows an individual control structure entry in the control table. Each entry is aligned on a 16-byte boundary. The entry contains four long words: the source end pointer, the destination end pointer, the control word, and an unused entry. The end pointers point to the ending address of the transfer and are inclusive. If the source or destination is non-incrementing (as for a peripheral register), then the pointer should point to the transfer address.

Table 8-4. Channel Control Structure

Offset	Description
0x000	Source End Pointer
0x004	Destination End Pointer
0x008	Control Word
0x00C	Unused

The control word contains the following fields:

- Source and destination data sizes
- Source and destination address increment size
- Number of transfers before bus arbitration
- Total number of items to transfer
- Useburst flag
- Transfer mode

The control word and each field are described in detail in “ μ DMA Channel Control Structure” on page 582. The μ DMA controller updates the transfer size and transfer mode fields as the transfer is performed. At the end of a transfer, the transfer size indicates 0, and the transfer mode indicates "stopped." Because the control word is modified by the μ DMA controller, it must be reconfigured before each new transfer. The source and destination end pointers are not modified, so they can be left unchanged if the source or destination addresses remain the same.

Prior to starting a transfer, a μ DMA channel must be enabled by setting the appropriate bit in the **DMA Channel Enable Set (DMAENASET)** register. A channel can be disabled by setting the channel bit in the **DMA Channel Enable Clear (DMAENACLR)** register. At the end of a complete μ DMA transfer, the controller automatically disables the channel.

8.2.6 Transfer Modes

The μ DMA controller supports several transfer modes. Two of the modes support simple one-time transfers. Several complex modes support a continuous flow of data.

8.2.6.1 Stop Mode

While Stop is not actually a transfer mode, it is a valid value for the mode field of the control word. When the mode field has this value, the μ DMA controller does not perform any transfers and disables the channel if it is enabled. At the end of a transfer, the μ DMA controller updates the control word to set the mode to Stop.

8.2.6.2 Basic Mode

In Basic mode, the μ DMA controller performs transfers as long as there are more items to transfer, and a transfer request is present. This mode is used with peripherals that assert a μ DMA request signal whenever the peripheral is ready for a data transfer. Basic mode should not be used in any situation where the request is momentary even though the entire transfer should be completed. For example, a software-initiated transfer creates a momentary request, and in Basic mode, only the number of transfers specified by the `ARBSIZE` field in the **DMA Channel Control Word (DMACHCTL)** register is transferred on a software request, even if there is more data to transfer.

When all of the items have been transferred using Basic mode, the μ DMA controller sets the mode for that channel to Stop.

8.2.6.3 Auto Mode

Auto mode is similar to Basic mode, except that once a transfer request is received, the transfer runs to completion, even if the μ DMA request is removed. This mode is suitable for software-triggered transfers. Generally, Auto mode is not used with a peripheral.

When all the items have been transferred using Auto mode, the μ DMA controller sets the mode for that channel to Stop.

8.2.6.4 Ping-Pong

Ping-Pong mode is used to support a continuous data flow to or from a peripheral. To use Ping-Pong mode, both the primary and alternate data structures must be implemented. Both structures are set up by the processor for data transfer between memory and a peripheral. The transfer is started using the primary control structure. When the transfer using the primary control structure is complete, the μ DMA controller reads the alternate control structure for that channel to continue the transfer. Each time this happens, an interrupt is generated, and the processor can reload the control structure for the just-completed transfer. Data flow can continue indefinitely this way, using the primary and alternate control structures to switch back and forth between buffers as the data flows to or from the peripheral.

Refer to Figure 8-2 on page 566 for an example showing operation in Ping-Pong mode.

Figure 8-2. Example of Ping-Pong μ DMA Transaction

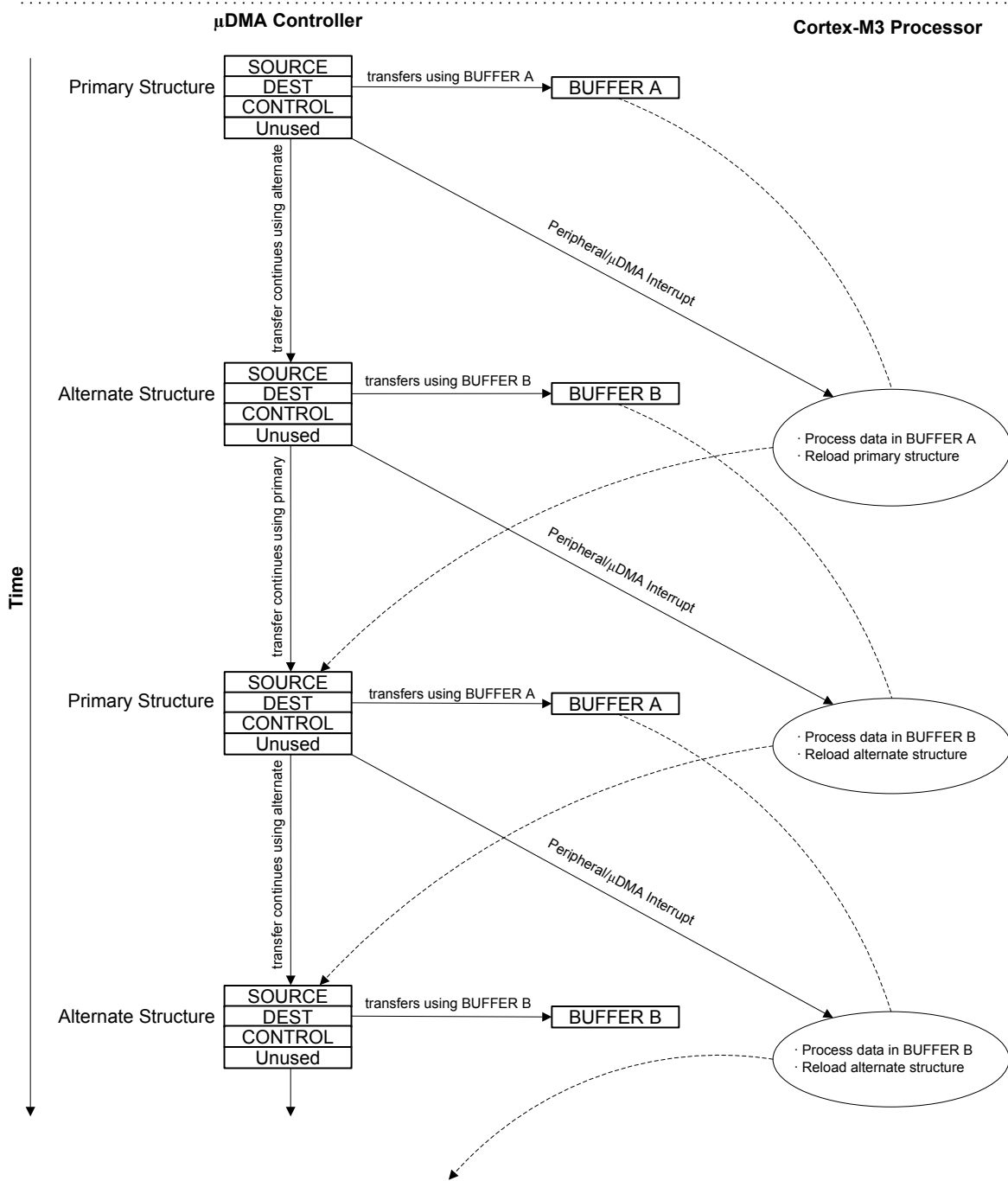

8.2.6.5 Memory Scatter-Gather

Memory Scatter-Gather mode is a complex mode used when data must be transferred to or from varied locations in memory instead of a set of contiguous locations in a memory buffer. For example,

a gather μ DMA operation could be used to selectively read the payload of several stored packets of a communication protocol and store them together in sequence in a memory buffer.

In Memory Scatter-Gather mode, the primary control structure is used to program the alternate control structure from a table in memory. The table is set up by the processor software and contains a list of control structures, each containing the source and destination end pointers, and the control word for a specific transfer. The mode of each control word must be set to Scatter-Gather mode. Each entry in the table is copied in turn to the alternate structure where it is then executed. The μ DMA controller alternates between using the primary control structure to copy the next transfer instruction from the list and then executing the new transfer instruction. The end of the list is marked by programming the control word for the last entry to use Auto transfer mode. Once the last transfer is performed using Auto mode, the μ DMA controller stops. A completion interrupt is generated only after the last transfer. It is possible to loop the list by having the last entry copy the primary control structure to point back to the beginning of the list (or to a new list). It is also possible to trigger a set of other channels to perform a transfer, either directly, by programming a write to the software trigger for another channel, or indirectly, by causing a peripheral action that results in a μ DMA request.

By programming the μ DMA controller using this method, a set of arbitrary transfers can be performed based on a single μ DMA request.

Refer to Figure 8-3 on page 568 and Figure 8-4 on page 569, which show an example of operation in Memory Scatter-Gather mode. This example shows a *gather* operation, where data in three separate buffers in memory is copied together into one buffer. Figure 8-3 on page 568 shows how the application sets up a μ DMA task list in memory that is used by the controller to perform three sets of copy operations from different locations in memory. The primary control structure for the channel that is used for the operation is configured to copy from the task list to the alternate control structure.

Figure 8-4 on page 569 shows the sequence as the μ DMA controller performs the three sets of copy operations. First, using the primary control structure, the μ DMA controller loads the alternate control structure with task A. It then performs the copy operation specified by task A, copying the data from the source buffer A to the destination buffer. Next, the μ DMA controller again uses the primary control structure to load task B into the alternate control structure, and then performs the B operation with the alternate control structure. The process is repeated for task C.

Figure 8-3. Memory Scatter-Gather, Setup and Configuration

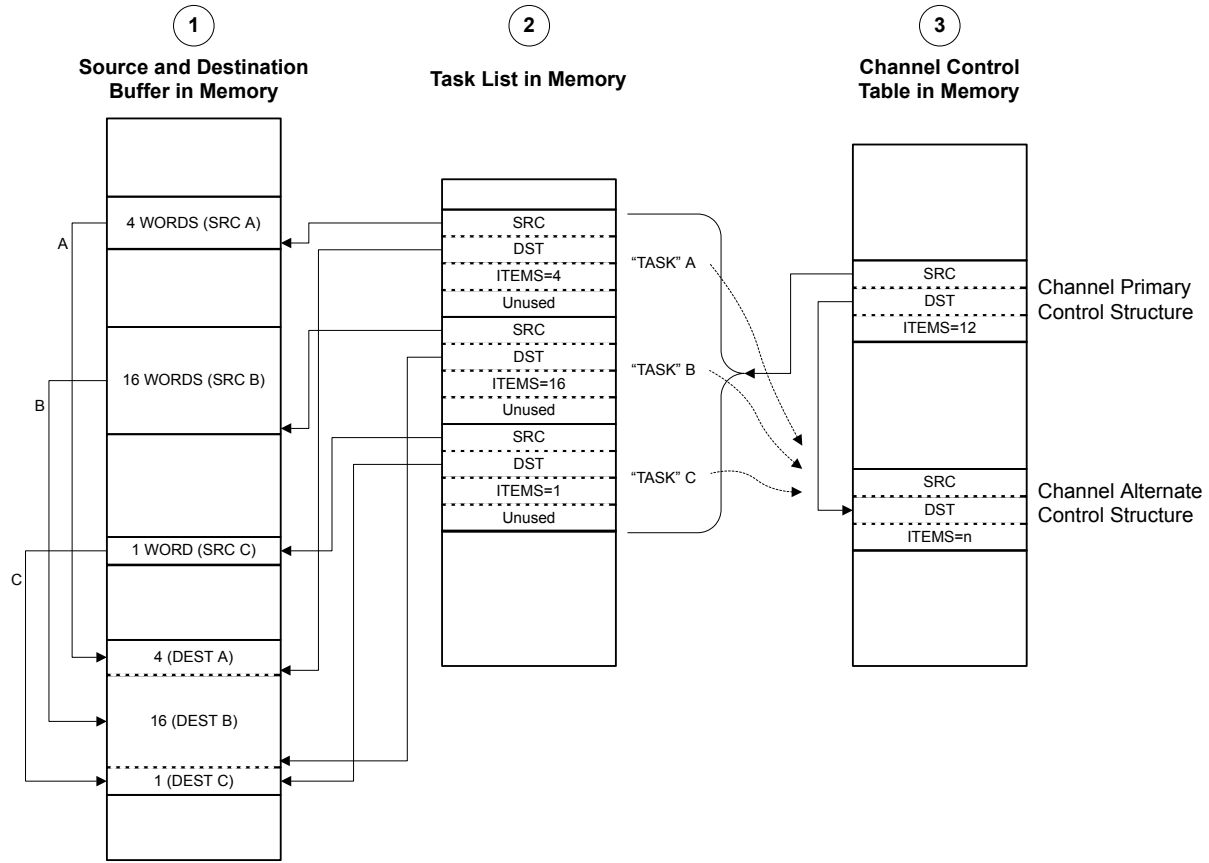

NOTES:

1. Application has a need to copy data items from three separate locations in memory into one combined buffer.
2. Application sets up μ DMA "task list" in memory, which contains the pointers and control configuration for three μ DMA copy "tasks."
3. Application sets up the channel primary control structure to copy each task configuration, one at a time, to the alternate control structure, where it is executed by the μ DMA controller.
4. The SRC and DST pointers in the task list must point to the last location in the corresponding buffer.

Figure 8-4. Memory Scatter-Gather, μ DMA Copy Sequence

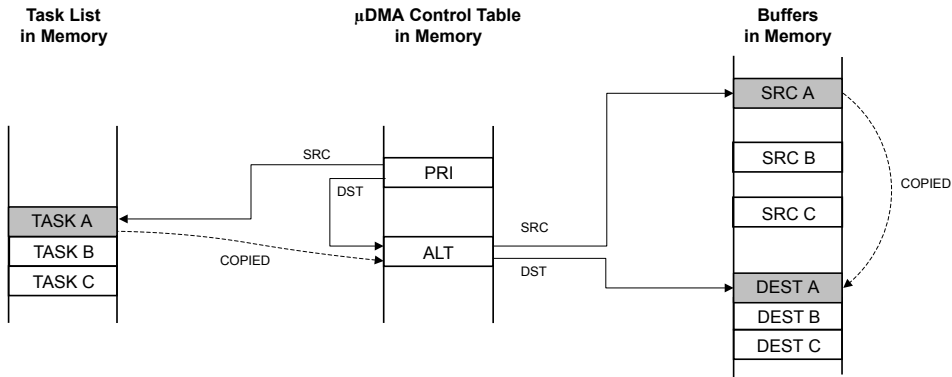

Using the channel's primary control structure, the μ DMA controller copies task A configuration to the channel's alternate control structure.

Then, using the channel's alternate control structure, the μ DMA controller copies data from the source buffer A to the destination buffer.

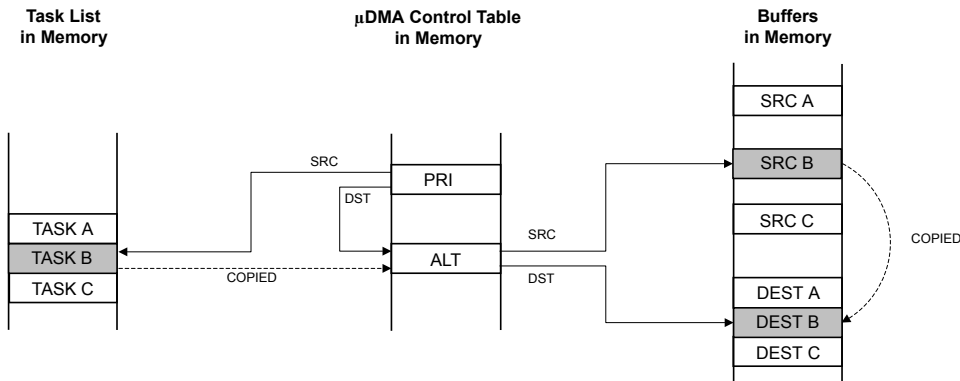

Using the channel's primary control structure, the μ DMA controller copies task B configuration to the channel's alternate control structure.

Then, using the channel's alternate control structure, the μ DMA controller copies data from the source buffer B to the destination buffer.

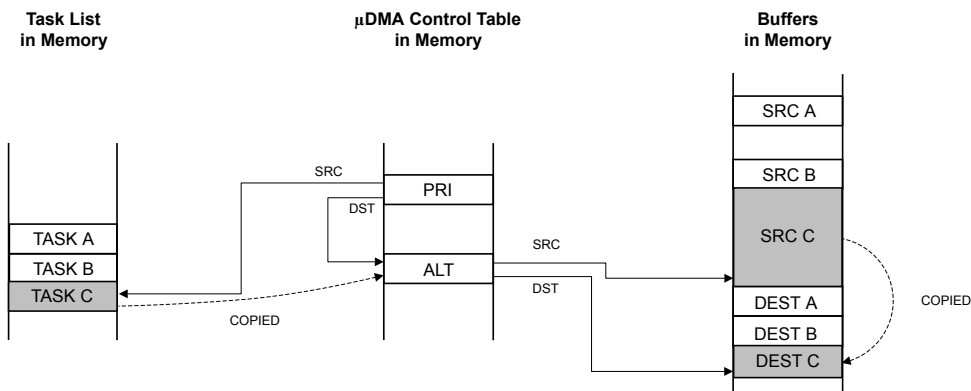

Using the channel's primary control structure, the μ DMA controller copies task C configuration to the channel's alternate control structure.

Then, using the channel's alternate control structure, the μ DMA controller copies data from the source buffer C to the destination buffer.

8.2.6.6 Peripheral Scatter-Gather

Peripheral Scatter-Gather mode is very similar to Memory Scatter-Gather, except that the transfers are controlled by a peripheral making a μ DMA request. Upon detecting a request from the peripheral, the μ DMA controller uses the primary control structure to copy one entry from the list to the alternate control structure and then performs the transfer. At the end of this transfer, the next transfer is started only if the peripheral again asserts a μ DMA request. The μ DMA controller continues to perform transfers from the list only when the peripheral is making a request, until the last transfer is complete. A completion interrupt is generated only after the last transfer.

By using this method, the μ DMA controller can transfer data to or from a peripheral from a set of arbitrary locations whenever the peripheral is ready to transfer data.

Refer to Figure 8-5 on page 571 and Figure 8-6 on page 572, which show an example of operation in Peripheral Scatter-Gather mode. This example shows a gather operation, where data from three separate buffers in memory is copied to a single peripheral data register. Figure 8-5 on page 571 shows how the application sets up a μ DMA task list in memory that is used by the controller to perform three sets of copy operations from different locations in memory. The primary control structure for the channel that is used for the operation is configured to copy from the task list to the alternate control structure.

Figure 8-6 on page 572 shows the sequence as the μ DMA controller performs the three sets of copy operations. First, using the primary control structure, the μ DMA controller loads the alternate control structure with task A. It then performs the copy operation specified by task A, copying the data from the source buffer A to the peripheral data register. Next, the μ DMA controller again uses the primary control structure to load task B into the alternate control structure, and then performs the B operation with the alternate control structure. The process is repeated for task C.

Figure 8-5. Peripheral Scatter-Gather, Setup and Configuration

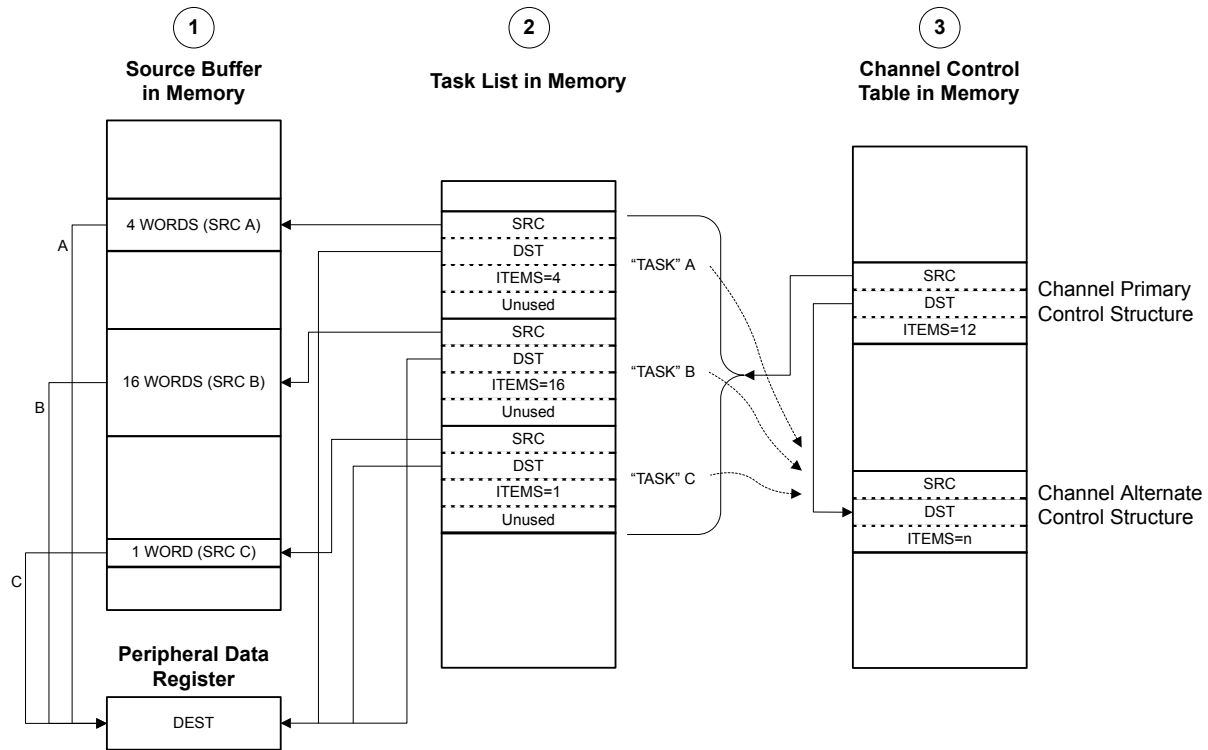

NOTES:

1. Application has a need to copy data items from three separate locations in memory into a peripheral data register.
2. Application sets up μ DMA "task list" in memory, which contains the pointers and control configuration for three μ DMA copy "tasks."
3. Application sets up the channel primary control structure to copy each task configuration, one at a time, to the alternate control structure, where it is executed by the μ DMA controller.

Figure 8-6. Peripheral Scatter-Gather, μ DMA Copy Sequence

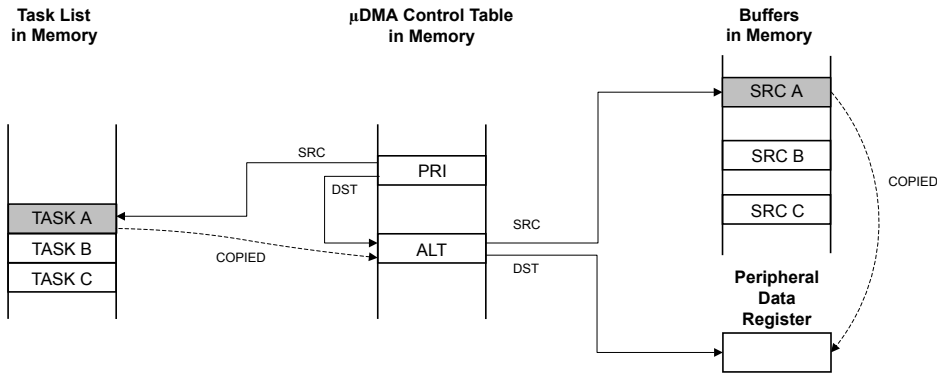

Using the channel's primary control structure, the μ DMA controller copies task A configuration to the channel's alternate control structure.

Then, using the channel's alternate control structure, the μ DMA controller copies data from the source buffer A to the peripheral data register.

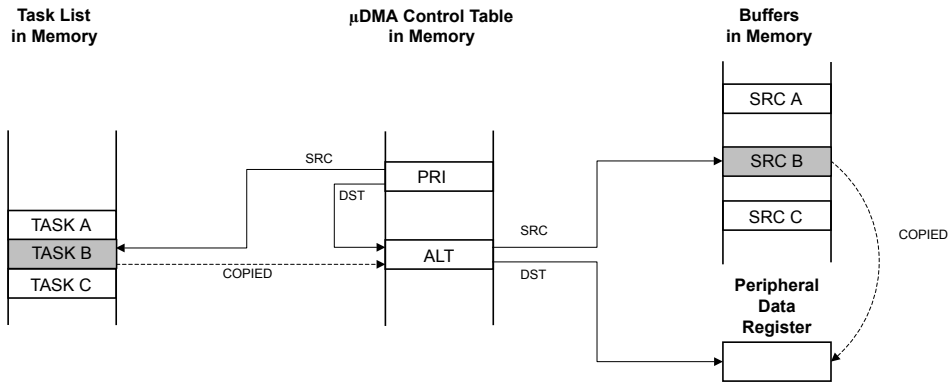

Using the channel's primary control structure, the μ DMA controller copies task B configuration to the channel's alternate control structure.

Then, using the channel's alternate control structure, the μ DMA controller copies data from the source buffer B to the peripheral data register.

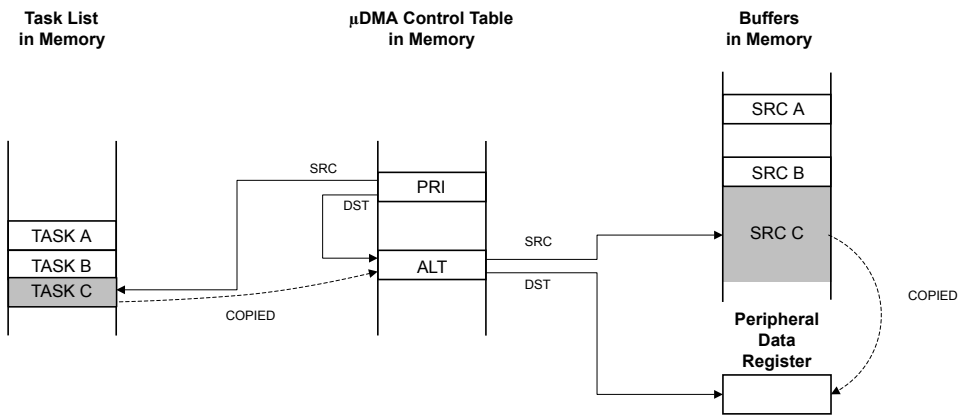

Using the channel's primary control structure, the μ DMA controller copies task C configuration to the channel's alternate control structure.

Then, using the channel's alternate control structure, the μ DMA controller copies data from the source buffer C to the peripheral data register.

8.2.7 Transfer Size and Increment

The μ DMA controller supports transfer data sizes of 8, 16, or 32 bits. The source and destination data size must be the same for any given transfer. The source and destination address can be auto-incremented by bytes, half-words, or words, or can be set to no increment. The source and destination address increment values can be set independently, and it is not necessary for the address increment to match the data size as long as the increment is the same or larger than the data size. For example, it is possible to perform a transfer using 8-bit data size, but using an address increment of full words (4 bytes). The data to be transferred must be aligned in memory according to the data size (8, 16, or 32 bits).

Table 8-5 shows the configuration to read from a peripheral that supplies 8-bit data.

Table 8-5. μ DMA Read Example: 8-Bit Peripheral

Field	Configuration
Source data size	8 bits
Destination data size	8 bits
Source address increment	No increment
Destination address increment	Byte
Source end pointer	Peripheral read FIFO register
Destination end pointer	End of the data buffer in memory

8.2.8 Peripheral Interface

Each peripheral that supports μ DMA has a single request and/or burst request signal that is asserted when the peripheral is ready to transfer data (see Table 8-2 on page 563). The request signal can be disabled or enabled using the **DMA Channel Request Mask Set (DMAREQMASKSET)** and **DMA Channel Request Mask Clear (DMAREQMASKCLR)** registers. The μ DMA request signal is disabled, or masked, when the channel request mask bit is set. When the request is not masked, the μ DMA channel is configured correctly and enabled, and the peripheral asserts the request signal, the μ DMA controller begins the transfer.

Note: When using μ DMA to transfer data to and from a peripheral, the peripheral must disable all interrupts to the NVIC.

When a μ DMA transfer is complete, the μ DMA controller generates an interrupt, see “Interrupts and Errors” on page 574 for more information.

For more information on how a specific peripheral interacts with the μ DMA controller, refer to the DMA Operation section in the chapter that discusses that peripheral.

8.2.9 Software Request

One μ DMA channel is dedicated to software-initiated transfers. This channel also has a dedicated interrupt to signal completion of a μ DMA transfer. A transfer is initiated by software by first configuring and enabling the transfer, and then issuing a software request using the **DMA Channel Software Request (DMASWREQ)** register. For software-based transfers, the Auto transfer mode should be used.

It is possible to initiate a transfer on any channel using the **DMASWREQ** register. If a request is initiated by software using a peripheral μ DMA channel, then the completion interrupt occurs on the interrupt vector for the peripheral instead of the software interrupt vector. Any channel may be used for software requests as long as the corresponding peripheral is not using μ DMA for data transfer.

8.2.10 Interrupts and Errors

When a μ DMA transfer is complete, the μ DMA controller generates a completion interrupt on the interrupt vector of the peripheral. Therefore, if μ DMA is used to transfer data for a peripheral and interrupts are used, then the interrupt handler for that peripheral must be designed to handle the μ DMA transfer completion interrupt. If the transfer uses the software μ DMA channel, then the completion interrupt occurs on the dedicated software μ DMA interrupt vector (see Table 8-6 on page 574).

When μ DMA is enabled for a peripheral, the μ DMA controller stops the normal transfer interrupts for a peripheral from reaching the interrupt controller (the interrupts are still reported in the peripheral's interrupt registers). Thus, when a large amount of data is transferred using μ DMA, instead of receiving multiple interrupts from the peripheral as data flows, the interrupt controller receives only one interrupt when the transfer is complete. Unmasked peripheral error interrupts continue to be sent to the interrupt controller.

When a μ DMA channel generates a completion interrupt, the `CHIS` bit corresponding to the peripheral channel is set in the **DMA Channel Interrupt Status (DMACHIS)** register (see page 609). This register can be used by the peripheral interrupt handler code to determine if the interrupt was caused by the μ DMA channel or an error event reported by the peripheral's interrupt registers. The completion interrupt request from the μ DMA controller is automatically cleared when the interrupt handler is activated.

If the μ DMA controller encounters a bus or memory protection error as it attempts to perform a data transfer, it disables the μ DMA channel that caused the error and generates an interrupt on the μ DMA error interrupt vector. The processor can read the **DMA Bus Error Clear (DMAERRCLR)** register to determine if an error is pending. The `ERRCLR` bit is set if an error occurred. The error can be cleared by writing a 1 to the `ERRCLR` bit.

Table 8-6 shows the dedicated interrupt assignments for the μ DMA controller.

Table 8-6. μ DMA Interrupt Assignments

Interrupt	Assignment
46	μ DMA Software Channel Transfer
47	μ DMA Error

8.3 Initialization and Configuration

8.3.1 Module Initialization

Before the μ DMA controller can be used, it must be enabled in the System Control block and in the peripheral. The location of the channel control structure must also be programmed.

The following steps should be performed one time during system initialization:

1. Enable the μ DMA clock using the **RCGCDMA** register (see page 321).
2. Enable the μ DMA controller by setting the `MASTEREN` bit of the **DMA Configuration (DMACFG)** register.
3. Program the location of the channel control table by writing the base address of the table to the **DMA Channel Control Base Pointer (DMACTLBASE)** register. The base address must be aligned on a 1024-byte boundary.

8.3.2 Configuring a Memory-to-Memory Transfer

μDMA channel 30 is dedicated for software-initiated transfers. However, any channel can be used for software-initiated, memory-to-memory transfer if the associated peripheral is not being used.

8.3.2.1 Configure the Channel Attributes

First, configure the channel attributes:

1. Program bit 30 of the **DMA Channel Priority Set (DMAPRIOSET)** or **DMA Channel Priority Clear (DMAPRIOCLR)** registers to set the channel to High priority or Default priority.
2. Set bit 30 of the **DMA Channel Primary Alternate Clear (DMAALTCLR)** register to select the primary channel control structure for this transfer.
3. Set bit 30 of the **DMA Channel Useburst Clear (DMAUSEBURSTCLR)** register to allow the μDMA controller to respond to single and burst requests.
4. Set bit 30 of the **DMA Channel Request Mask Clear (DMAREQMASKCLR)** register to allow the μDMA controller to recognize requests for this channel.

8.3.2.2 Configure the Channel Control Structure

Now the channel control structure must be configured.

This example transfers 256 words from one memory buffer to another. Channel 30 is used for a software transfer, and the control structure for channel 30 is at offset 0x1E0 of the channel control table. The channel control structure for channel 30 is located at the offsets shown in Table 8-7.

Table 8-7. Channel Control Structure Offsets for Channel 30

Offset	Description
Control Table Base + 0x1E0	Channel 30 Source End Pointer
Control Table Base + 0x1E4	Channel 30 Destination End Pointer
Control Table Base + 0x1E8	Channel 30 Control Word

Configure the Source and Destination

The source and destination end pointers must be set to the last address for the transfer (inclusive).

1. Program the source end pointer at offset 0x1E0 to the address of the source buffer + 0x3FC.
2. Program the destination end pointer at offset 0x1E4 to the address of the destination buffer + 0x3FC.

The control word at offset 0x1E8 must be programmed according to Table 8-8.

Table 8-8. Channel Control Word Configuration for Memory Transfer Example

Field in DMACHCTL	Bits	Value	Description
DSTINC	31:30	2	32-bit destination address increment
DSTSIZE	29:28	2	32-bit destination data size
SRCINC	27:26	2	32-bit source address increment
SRCSIZE	25:24	2	32-bit source data size
reserved	23:18	0	Reserved

Table 8-8. Channel Control Word Configuration for Memory Transfer Example (continued)

Field in DMACHCTL	Bits	Value	Description
ARBSIZE	17:14	3	Arbitrates after 8 transfers
XFERSIZE	13:4	255	Transfer 256 items
NXTUSEBURST	3	0	N/A for this transfer type
XFERMODE	2:0	2	Use Auto-request transfer mode

8.3.2.3 Start the Transfer

Now the channel is configured and is ready to start.

1. Enable the channel by setting bit 30 of the **DMA Channel Enable Set (DMAENASET)** register.
2. Issue a transfer request by setting bit 30 of the **DMA Channel Software Request (DMASWREQ)** register.

The μ DMA transfer begins. If the interrupt is enabled, then the processor is notified by interrupt when the transfer is complete. If needed, the status can be checked by reading bit 30 of the **DMAENASET** register. This bit is automatically cleared when the transfer is complete. The status can also be checked by reading the **XFERMODE** field of the channel control word at offset 0x1E8. This field is automatically cleared at the end of the transfer.

8.3.3 Configuring a Peripheral for Simple Transmit

This example configures the μ DMA controller to transmit a buffer of data to a peripheral. The peripheral has a transmit FIFO with a trigger level of 4. The example peripheral uses μ DMA channel 7.

8.3.3.1 Configure the Channel Attributes

First, configure the channel attributes:

1. Configure bit 7 of the **DMA Channel Priority Set (DMAPRIOSET)** or **DMA Channel Priority Clear (DMAPRIOCLR)** registers to set the channel to High priority or Default priority.
2. Set bit 7 of the **DMA Channel Primary Alternate Clear (DMAALTCLR)** register to select the primary channel control structure for this transfer.
3. Set bit 7 of the **DMA Channel Useburst Clear (DMAUSEBURSTCLR)** register to allow the μ DMA controller to respond to single and burst requests.
4. Set bit 7 of the **DMA Channel Request Mask Clear (DMAREQMASKCLR)** register to allow the μ DMA controller to recognize requests for this channel.

8.3.3.2 Configure the Channel Control Structure

This example transfers 64 bytes from a memory buffer to the peripheral's transmit FIFO register using μ DMA channel 7. The control structure for channel 7 is at offset 0x070 of the channel control table. The channel control structure for channel 7 is located at the offsets shown in Table 8-9.

Table 8-9. Channel Control Structure Offsets for Channel 7

Offset	Description
Control Table Base + 0x070	Channel 7 Source End Pointer

Table 8-9. Channel Control Structure Offsets for Channel 7 (continued)

Offset	Description
Control Table Base + 0x074	Channel 7 Destination End Pointer
Control Table Base + 0x078	Channel 7 Control Word

Configure the Source and Destination

The source and destination end pointers must be set to the last address for the transfer (inclusive). Because the peripheral pointer does not change, it simply points to the peripheral's data register.

1. Program the source end pointer at offset 0x070 to the address of the source buffer + 0x3F.
2. Program the destination end pointer at offset 0x074 to the address of the peripheral's transmit FIFO register.

The control word at offset 0x078 must be programmed according to Table 8-10.

Table 8-10. Channel Control Word Configuration for Peripheral Transmit Example

Field in DMACHCTL	Bits	Value	Description
DSTINC	31:30	3	Destination address does not increment
DSTSIZE	29:28	0	8-bit destination data size
SRCINC	27:26	0	8-bit source address increment
SRCSIZE	25:24	0	8-bit source data size
reserved	23:18	0	Reserved
ARBSIZE	17:14	2	Arbitrates after 4 transfers
XFERSIZE	13:4	63	Transfer 64 items
NXTUSEBURST	3	0	N/A for this transfer type
XFERMODE	2:0	1	Use Basic transfer mode

Note: In this example, it is not important if the peripheral makes a single request or a burst request. Because the peripheral has a FIFO that triggers at a level of 4, the arbitration size is set to 4. If the peripheral does make a burst request, then 4 bytes are transferred, which is what the FIFO can accommodate. If the peripheral makes a single request (if there is any space in the FIFO), then one byte is transferred at a time. If it is important to the application that transfers only be made in bursts, then the Channel Useburst `SET[7]` bit should be set in the **DMA Channel Useburst Set (DMAUSEBURSTSET)** register.

8.3.3.3 Start the Transfer

Now the channel is configured and is ready to start.

1. Enable the channel by setting bit 7 of the **DMA Channel Enable Set (DMAENASET)** register.

The μ DMA controller is now configured for transfer on channel 7. The controller makes transfers to the peripheral whenever the peripheral asserts a μ DMA request. The transfers continue until the entire buffer of 64 bytes has been transferred. When that happens, the μ DMA controller disables the channel and sets the `XFERMODE` field of the channel control word to 0 (Stopped). The status of the transfer can be checked by reading bit 7 of the **DMA Channel Enable Set (DMAENASET)** register. This bit is automatically cleared when the transfer is complete. The status can also be checked by reading the `XFERMODE` field of the channel control word at offset 0x078. This field is automatically cleared at the end of the transfer.

If peripheral interrupts are enabled, then the peripheral interrupt handler receives an interrupt when the entire transfer is complete.

8.3.4 Configuring a Peripheral for Ping-Pong Receive

This example configures the μ DMA controller to continuously receive 8-bit data from a peripheral into a pair of 64-byte buffers. The peripheral has a receive FIFO with a trigger level of 8. The example peripheral uses μ DMA channel 8.

8.3.4.1 Configure the Channel Attributes

First, configure the channel attributes:

1. Configure bit 8 of the **DMA Channel Priority Set (DMAPRIOSET)** or **DMA Channel Priority Clear (DMAPRIOCLR)** registers to set the channel to High priority or Default priority.
2. Set bit 8 of the **DMA Channel Primary Alternate Clear (DMAALTCLR)** register to select the primary channel control structure for this transfer.
3. Set bit 8 of the **DMA Channel Useburst Clear (DMAUSEBURSTCLR)** register to allow the μ DMA controller to respond to single and burst requests.
4. Set bit 8 of the **DMA Channel Request Mask Clear (DMAREQMASKCLR)** register to allow the μ DMA controller to recognize requests for this channel.

8.3.4.2 Configure the Channel Control Structure

This example transfers bytes from the peripheral's receive FIFO register into two memory buffers of 64 bytes each. As data is received, when one buffer is full, the μ DMA controller switches to use the other.

To use Ping-Pong buffering, both primary and alternate channel control structures must be used. The primary control structure for channel 8 is at offset 0x080 of the channel control table, and the alternate channel control structure is at offset 0x280. The channel control structures for channel 8 are located at the offsets shown in Table 8-11.

Table 8-11. Primary and Alternate Channel Control Structure Offsets for Channel 8

Offset	Description
Control Table Base + 0x080	Channel 8 Primary Source End Pointer
Control Table Base + 0x084	Channel 8 Primary Destination End Pointer
Control Table Base + 0x088	Channel 8 Primary Control Word
Control Table Base + 0x280	Channel 8 Alternate Source End Pointer
Control Table Base + 0x284	Channel 8 Alternate Destination End Pointer
Control Table Base + 0x288	Channel 8 Alternate Control Word

Configure the Source and Destination

The source and destination end pointers must be set to the last address for the transfer (inclusive). Because the peripheral pointer does not change, it simply points to the peripheral's data register. Both the primary and alternate sets of pointers must be configured.

1. Program the primary source end pointer at offset 0x080 to the address of the peripheral's receive buffer.

2. Program the primary destination end pointer at offset 0x084 to the address of ping-pong buffer A + 0x3F.
3. Program the alternate source end pointer at offset 0x280 to the address of the peripheral's receive buffer.
4. Program the alternate destination end pointer at offset 0x284 to the address of ping-pong buffer B + 0x3F.

The primary control word at offset 0x088 and the alternate control word at offset 0x288 are initially programmed the same way.

1. Program the primary channel control word at offset 0x088 according to Table 8-12.
2. Program the alternate channel control word at offset 0x288 according to Table 8-12.

Table 8-12. Channel Control Word Configuration for Peripheral Ping-Pong Receive Example

Field in DMACHCTL	Bits	Value	Description
DSTINC	31:30	0	8-bit destination address increment
DSTSIZE	29:28	0	8-bit destination data size
SRCINC	27:26	3	Source address does not increment
SRCSIZE	25:24	0	8-bit source data size
reserved	23:18	0	Reserved
ARBSIZE	17:14	3	Arbitrates after 8 transfers
XFERSIZE	13:4	63	Transfer 64 items
NXTUSEBURST	3	0	N/A for this transfer type
XFERMODE	2:0	3	Use Ping-Pong transfer mode

Note: In this example, it is not important if the peripheral makes a single request or a burst request. Because the peripheral has a FIFO that triggers at a level of 8, the arbitration size is set to 8. If the peripheral does make a burst request, then 8 bytes are transferred, which is what the FIFO can accommodate. If the peripheral makes a single request (if there is any data in the FIFO), then one byte is transferred at a time. If it is important to the application that transfers only be made in bursts, then the Channel Useburst `SET[8]` bit should be set in the **DMA Channel Useburst Set (DMAUSEBURSTSET)** register.

8.3.4.3 Configure the Peripheral Interrupt

An interrupt handler should be configured when using μ DMA Ping-Pong mode, it is best to use an interrupt handler. However, the Ping-Pong mode can be configured without interrupts by polling. The interrupt handler is triggered after each buffer is complete.

1. Configure and enable an interrupt handler for the peripheral.

8.3.4.4 Enable the μ DMA Channel

Now the channel is configured and is ready to start.

1. Enable the channel by setting bit 8 of the **DMA Channel Enable Set (DMAENASET)** register.

8.3.4.5 Process Interrupts

The μ DMA controller is now configured and enabled for transfer on channel 8. When the peripheral asserts the μ DMA request signal, the μ DMA controller makes transfers into buffer A using the primary channel control structure. When the primary transfer to buffer A is complete, it switches to the alternate channel control structure and makes transfers into buffer B. At the same time, the primary channel control word mode field is configured to indicate Stopped, and an interrupt is pending.

When an interrupt is triggered, the interrupt handler must determine which buffer is complete and process the data or set a flag that the data must be processed by non-interrupt buffer processing code. Then the next buffer transfer must be set up.

In the interrupt handler:

1. Read the primary channel control word at offset 0x088 and check the `XFERMODE` field. If the field is 0, this means buffer A is complete. If buffer A is complete, then:
 - a. Process the newly received data in buffer A or signal the buffer processing code that buffer A has data available.
 - b. Reprogram the primary channel control word at offset 0x88 according to Table 8-12 on page 579.
2. Read the alternate channel control word at offset 0x288 and check the `XFERMODE` field. If the field is 0, this means buffer B is complete. If buffer B is complete, then:
 - a. Process the newly received data in buffer B or signal the buffer processing code that buffer B has data available.
 - b. Reprogram the alternate channel control word at offset 0x288 according to Table 8-12 on page 579.

8.3.5 Configuring Channel Assignments

Channel assignments for each μ DMA channel can be changed using the `DMACHMAPn` registers. Each 4-bit field represents a μ DMA channel.

Refer to Table 8-1 on page 561 for channel assignments.

8.4 Register Map

Table 8-13 on page 581 lists the μ DMA channel control structures and registers. The channel control structure shows the layout of one entry in the channel control table. The channel control table is located in system memory, and the location is determined by the application, thus, the base address is n/a (not applicable) and noted as so above the register descriptions. In the table below, the offset for the channel control structures is the offset from the entry in the channel control table. See "Channel Configuration" on page 563 and Table 8-3 on page 564 for a description of how the entries in the channel control table are located in memory. The μ DMA register addresses are given as a hexadecimal increment, relative to the μ DMA base address of 0x400F.F000. Note that the μ DMA module clock must be enabled before the registers can be programmed (see page 321). There must be a delay of 3 system clocks after the μ DMA module clock is enabled before any μ DMA module registers are accessed.

Table 8-13. μ DMA Register Map

Offset	Name	Type	Reset	Description	See page
μDMA Channel Control Structure (Offset from Channel Control Table Base)					
0x000	DMASRCENDP	R/W	-	DMA Channel Source Address End Pointer	583
0x004	DMADSTENDP	R/W	-	DMA Channel Destination Address End Pointer	584
0x008	DMACHCTL	R/W	-	DMA Channel Control Word	585
μDMA Registers (Offset from μDMA Base Address)					
0x000	DMASTAT	RO	0x001F.0000	DMA Status	590
0x004	DMACFG	WO	-	DMA Configuration	592
0x008	DMACTLBASE	R/W	0x0000.0000	DMA Channel Control Base Pointer	593
0x00C	DMAALTBASE	RO	0x0000.0200	DMA Alternate Channel Control Base Pointer	594
0x010	DMAWAITSTAT	RO	0xFFFF.FFC0	DMA Channel Wait-on-Request Status	595
0x014	DMASWREQ	WO	-	DMA Channel Software Request	596
0x018	DMAUSEBURSTSET	R/W	0x0000.0000	DMA Channel Useburst Set	597
0x01C	DMAUSEBURSTCLR	WO	-	DMA Channel Useburst Clear	598
0x020	DMAREQMASKSET	R/W	0x0000.0000	DMA Channel Request Mask Set	599
0x024	DMAREQMASKCLR	WO	-	DMA Channel Request Mask Clear	600
0x028	DMAENASET	R/W	0x0000.0000	DMA Channel Enable Set	601
0x02C	DMAENACLAR	WO	-	DMA Channel Enable Clear	602
0x030	DMAALTSET	R/W	0x0000.0000	DMA Channel Primary Alternate Set	603
0x034	DMAALTCLR	WO	-	DMA Channel Primary Alternate Clear	604
0x038	DMAPRIOSET	R/W	0x0000.0000	DMA Channel Priority Set	605
0x03C	DMAPRIOCLR	WO	-	DMA Channel Priority Clear	606
0x04C	DMAERRCLR	R/W	0x0000.0000	DMA Bus Error Clear	607
0x500	DMACHASGN	R/W	0x0000.0000	DMA Channel Assignment	608
0x504	DMACHIS	R/W1C	0x0000.0000	DMA Channel Interrupt Status	609
0x510	DMACHMAP0	R/W	0x0000.0000	DMA Channel Map Select 0	610
0x514	DMACHMAP1	R/W	0x0000.0000	DMA Channel Map Select 1	611
0x518	DMACHMAP2	R/W	0x0000.0000	DMA Channel Map Select 2	612
0x51C	DMACHMAP3	R/W	0x0000.0000	DMA Channel Map Select 3	613
0xFD0	DMAPeriphID4	RO	0x0000.0004	DMA Peripheral Identification 4	618
0xFE0	DMAPeriphID0	RO	0x0000.0030	DMA Peripheral Identification 0	614
0xFE4	DMAPeriphID1	RO	0x0000.00B2	DMA Peripheral Identification 1	615
0xFE8	DMAPeriphID2	RO	0x0000.000B	DMA Peripheral Identification 2	616

Table 8-13. μ DMA Register Map (*continued*)

Offset	Name	Type	Reset	Description	See page
0xFEC	DMAPeriphID3	RO	0x0000.0000	DMA Peripheral Identification 3	617
0xFF0	DMAPrimeCellID0	RO	0x0000.000D	DMA PrimeCell Identification 0	619
0xFF4	DMAPrimeCellID1	RO	0x0000.00F0	DMA PrimeCell Identification 1	620
0xFF8	DMAPrimeCellID2	RO	0x0000.0005	DMA PrimeCell Identification 2	621
0xFFC	DMAPrimeCellID3	RO	0x0000.00B1	DMA PrimeCell Identification 3	622

8.5 μ DMA Channel Control Structure

The μ DMA Channel Control Structure holds the transfer settings for a μ DMA channel. Each channel has two control structures, which are located in a table in system memory. Refer to “Channel Configuration” on page 563 for an explanation of the Channel Control Table and the Channel Control Structure.

The channel control structure is one entry in the channel control table. Each channel has a primary and alternate structure. The primary control structures are located at offsets 0x0, 0x10, 0x20 and so on. The alternate control structures are located at offsets 0x200, 0x210, 0x220, and so on.

Register 1: DMA Channel Source Address End Pointer (DMASRCENDP), offset 0x000

DMA Channel Source Address End Pointer (DMASRCENDP) is part of the Channel Control Structure and is used to specify the source address for a μ DMA transfer.

The μ DMA controller can transfer data to and from the on-chip SRAM. However, because the Flash memory and ROM are located on a separate internal bus, it is not possible to transfer data to/from the Flash memory or ROM with the μ DMA controller.

Note: The offset specified is from the base address of the control structure in system memory, not the μ DMA module base address.

DMA Channel Source Address End Pointer (DMASRCENDP)

Base n/a
Offset 0x000
Type R/W, reset -

	31	30	29	28	27	26	25	24	23	22	21	20	19	18	17	16
	ADDR															
Type	R/W	R/W	R/W	R/W	R/W	R/W	R/W	R/W	R/W	R/W	R/W	R/W	R/W	R/W	R/W	R/W
Reset	-	-	-	-	-	-	-	-	-	-	-	-	-	-	-	-
	15	14	13	12	11	10	9	8	7	6	5	4	3	2	1	0
	ADDR															
Type	R/W	R/W	R/W	R/W	R/W	R/W	R/W	R/W	R/W	R/W	R/W	R/W	R/W	R/W	R/W	R/W
Reset	-	-	-	-	-	-	-	-	-	-	-	-	-	-	-	-

Bit/Field	Name	Type	Reset	Description
31:0	ADDR	R/W	-	Source Address End Pointer This field points to the last address of the μ DMA transfer source (inclusive). If the source address is not incrementing (the SRCINC field in the DMACHCTL register is 0x3), then this field points at the source location itself (such as a peripheral data register).

Register 2: DMA Channel Destination Address End Pointer (DMADSTENDP), offset 0x004

DMA Channel Destination Address End Pointer (DMADSTENDP) is part of the Channel Control Structure and is used to specify the destination address for a μ DMA transfer.

Note: The offset specified is from the base address of the control structure in system memory, not the μ DMA module base address.

DMA Channel Destination Address End Pointer (DMADSTENDP)

Base n/a
Offset 0x004
Type R/W, reset -

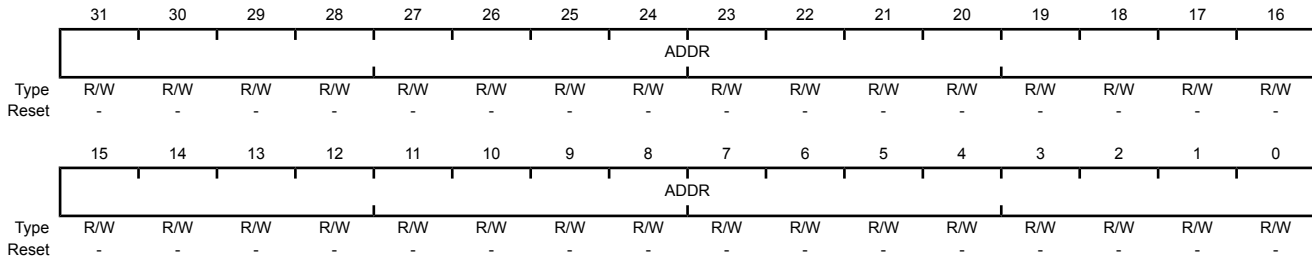

Bit/Field	Name	Type	Reset	Description
31:0	ADDR	R/W	-	Destination Address End Pointer This field points to the last address of the μ DMA transfer destination (inclusive). If the destination address is not incrementing (the <i>DSTINC</i> field in the DMACHCTL register is 0x3), then this field points at the destination location itself (such as a peripheral data register).

Register 3: DMA Channel Control Word (DMACHCTL), offset 0x008

DMA Channel Control Word (DMACHCTL) is part of the Channel Control Structure and is used to specify parameters of a μ DMA transfer.

Note: The offset specified is from the base address of the control structure in system memory, not the μ DMA module base address.

DMA Channel Control Word (DMACHCTL)

Base n/a
Offset 0x008
Type R/W, reset -

	31	30	29	28	27	26	25	24	23	22	21	20	19	18	17	16
	DSTINC		DSTSIZE		SRCINC		SRCSIZE		reserved				ARBSIZE			
Type	R/W	R/W	R/W	R/W	R/W	R/W	R/W	R/W	R/W	R/W	R/W	R/W	R/W	R/W	R/W	R/W
Reset	-	-	-	-	-	-	-	-	-	-	-	-	-	-	-	-
	15	14	13	12	11	10	9	8	7	6	5	4	3	2	1	0
	ARBSIZE		XFERSIZE										NXTUSEBURST	XFERMODE		
Type	R/W	R/W	R/W	R/W	R/W	R/W	R/W	R/W	R/W	R/W	R/W	R/W	R/W	R/W	R/W	R/W
Reset	-	-	-	-	-	-	-	-	-	-	-	-	-	-	-	-

Bit/Field	Name	Type	Reset	Description												
31:30	DSTINC	R/W	-	<p>Destination Address Increment</p> <p>This field configures the destination address increment.</p> <p>The address increment value must be equal or greater than the value of the destination size (DSTSIZE).</p> <p>Value Description</p> <table border="0"> <tr> <td>0x0</td> <td>Byte</td> <td>Increment by 8-bit locations</td> </tr> <tr> <td>0x1</td> <td>Half-word</td> <td>Increment by 16-bit locations</td> </tr> <tr> <td>0x2</td> <td>Word</td> <td>Increment by 32-bit locations</td> </tr> <tr> <td>0x3</td> <td>No increment</td> <td>Address remains set to the value of the Destination Address End Pointer (DMADSTENDP) for the channel</td> </tr> </table>	0x0	Byte	Increment by 8-bit locations	0x1	Half-word	Increment by 16-bit locations	0x2	Word	Increment by 32-bit locations	0x3	No increment	Address remains set to the value of the Destination Address End Pointer (DMADSTENDP) for the channel
0x0	Byte	Increment by 8-bit locations														
0x1	Half-word	Increment by 16-bit locations														
0x2	Word	Increment by 32-bit locations														
0x3	No increment	Address remains set to the value of the Destination Address End Pointer (DMADSTENDP) for the channel														
29:28	DSTSIZE	R/W	-	<p>Destination Data Size</p> <p>This field configures the destination item data size.</p> <p>Note: DSTSIZE must be the same as SRCSIZE.</p> <p>Value Description</p> <table border="0"> <tr> <td>0x0</td> <td>Byte</td> <td>8-bit data size</td> </tr> <tr> <td>0x1</td> <td>Half-word</td> <td>16-bit data size</td> </tr> <tr> <td>0x2</td> <td>Word</td> <td>32-bit data size</td> </tr> <tr> <td>0x3</td> <td>Reserved</td> <td></td> </tr> </table>	0x0	Byte	8-bit data size	0x1	Half-word	16-bit data size	0x2	Word	32-bit data size	0x3	Reserved	
0x0	Byte	8-bit data size														
0x1	Half-word	16-bit data size														
0x2	Word	32-bit data size														
0x3	Reserved															

Bit/Field	Name	Type	Reset	Description
27:26	SRCINC	R/W	-	<p>Source Address Increment</p> <p>This field configures the source address increment. The address increment value must be equal or greater than the value of the source size (SRCSIZE).</p> <p>Value Description</p> <p>0x0 Byte Increment by 8-bit locations</p> <p>0x1 Half-word Increment by 16-bit locations</p> <p>0x2 Word Increment by 32-bit locations</p> <p>0x3 No increment Address remains set to the value of the Source Address End Pointer (DMASRCENDE) for the channel</p>
25:24	SRCSIZE	R/W	-	<p>Source Data Size</p> <p>This field configures the source item data size.</p> <p>Note: DSTSIZE must be the same as SRCSIZE.</p> <p>Value Description</p> <p>0x0 Byte 8-bit data size.</p> <p>0x1 Half-word 16-bit data size.</p> <p>0x2 Word 32-bit data size.</p> <p>0x3 Reserved</p>
23:18	reserved	R/W	-	<p>Software should not rely on the value of a reserved bit. To provide compatibility with future products, the value of a reserved bit should be preserved across a read-modify-write operation.</p>

Bit/Field	Name	Type	Reset	Description																								
17:14	ARBSIZE	R/W	-	<p>Arbitration Size</p> <p>This field configures the number of transfers that can occur before the μDMA controller re-arbitrates. The possible arbitration rate configurations represent powers of 2 and are shown below.</p> <table border="1"> <thead> <tr> <th>Value</th> <th>Description</th> </tr> </thead> <tbody> <tr> <td>0x0</td> <td>1 Transfer Arbitrates after each μDMA transfer</td> </tr> <tr> <td>0x1</td> <td>2 Transfers</td> </tr> <tr> <td>0x2</td> <td>4 Transfers</td> </tr> <tr> <td>0x3</td> <td>8 Transfers</td> </tr> <tr> <td>0x4</td> <td>16 Transfers</td> </tr> <tr> <td>0x5</td> <td>32 Transfers</td> </tr> <tr> <td>0x6</td> <td>64 Transfers</td> </tr> <tr> <td>0x7</td> <td>128 Transfers</td> </tr> <tr> <td>0x8</td> <td>256 Transfers</td> </tr> <tr> <td>0x9</td> <td>512 Transfers</td> </tr> <tr> <td>0xA-0xF</td> <td>1024 Transfers</td> </tr> </tbody> </table> <p>In this configuration, no arbitration occurs during the μDMA transfer because the maximum transfer size is 1024.</p>	Value	Description	0x0	1 Transfer Arbitrates after each μ DMA transfer	0x1	2 Transfers	0x2	4 Transfers	0x3	8 Transfers	0x4	16 Transfers	0x5	32 Transfers	0x6	64 Transfers	0x7	128 Transfers	0x8	256 Transfers	0x9	512 Transfers	0xA-0xF	1024 Transfers
Value	Description																											
0x0	1 Transfer Arbitrates after each μ DMA transfer																											
0x1	2 Transfers																											
0x2	4 Transfers																											
0x3	8 Transfers																											
0x4	16 Transfers																											
0x5	32 Transfers																											
0x6	64 Transfers																											
0x7	128 Transfers																											
0x8	256 Transfers																											
0x9	512 Transfers																											
0xA-0xF	1024 Transfers																											
13:4	XFERSIZE	R/W	-	<p>Transfer Size (minus 1)</p> <p>This field configures the total number of items to transfer. The value of this field is 1 less than the number to transfer (value 0 means transfer 1 item). The maximum value for this 10-bit field is 1023 which represents a transfer size of 1024 items.</p> <p>The transfer size is the number of items, not the number of bytes. If the data size is 32 bits, then this value is the number of 32-bit words to transfer.</p> <p>The μDMA controller updates this field immediately prior to entering the arbitration process, so it contains the number of outstanding items that is necessary to complete the μDMA cycle.</p>																								
3	NXTUSEBURST	R/W	-	<p>Next Useburst</p> <p>This field controls whether the Useburst $SET[n]$ bit is automatically set for the last transfer of a peripheral scatter-gather operation. Normally, for the last transfer, if the number of remaining items to transfer is less than the arbitration size, the μDMA controller uses single transfers to complete the transaction. If this bit is set, then the controller uses a burst transfer to complete the last transfer.</p>																								

Bit/Field	Name	Type	Reset	Description																		
2:0	XFERMODE	R/W	-	<p>μDMA Transfer Mode</p> <p>This field configures the operating mode of the μDMA cycle. Refer to “Transfer Modes” on page 565 for a detailed explanation of transfer modes.</p> <p>Because this register is in system RAM, it has no reset value. Therefore, this field should be initialized to 0 before the channel is enabled.</p> <table border="1"> <thead> <tr> <th>Value</th> <th>Description</th> </tr> </thead> <tbody> <tr> <td>0x0</td> <td>Stop</td> </tr> <tr> <td>0x1</td> <td>Basic</td> </tr> <tr> <td>0x2</td> <td>Auto-Request</td> </tr> <tr> <td>0x3</td> <td>Ping-Pong</td> </tr> <tr> <td>0x4</td> <td>Memory Scatter-Gather</td> </tr> <tr> <td>0x5</td> <td>Alternate Memory Scatter-Gather</td> </tr> <tr> <td>0x6</td> <td>Peripheral Scatter-Gather</td> </tr> <tr> <td>0x7</td> <td>Alternate Peripheral Scatter-Gather</td> </tr> </tbody> </table>	Value	Description	0x0	Stop	0x1	Basic	0x2	Auto-Request	0x3	Ping-Pong	0x4	Memory Scatter-Gather	0x5	Alternate Memory Scatter-Gather	0x6	Peripheral Scatter-Gather	0x7	Alternate Peripheral Scatter-Gather
Value	Description																					
0x0	Stop																					
0x1	Basic																					
0x2	Auto-Request																					
0x3	Ping-Pong																					
0x4	Memory Scatter-Gather																					
0x5	Alternate Memory Scatter-Gather																					
0x6	Peripheral Scatter-Gather																					
0x7	Alternate Peripheral Scatter-Gather																					

XFERMODE Bit Field Values.

Stop

Channel is stopped or configuration data is invalid. No more transfers can occur.

Basic

For each trigger (whether from a peripheral or a software request), the μ DMA controller performs the number of transfers specified by the `ARBSIZE` field.

Auto-Request

The initial request (software- or peripheral-initiated) is sufficient to complete the entire transfer of `XFERSIZE` items without any further requests.

Ping-Pong

This mode uses both the primary and alternate control structures for this channel. When the number of transfers specified by the `XFERSIZE` field have completed for the current control structure (primary or alternate), the μ DMA controller switches to the other one. These switches continue until one of the control structures is not set to ping-pong mode. At that point, the μ DMA controller stops. An interrupt is generated on completion of the transfers configured by each control structure. See “Ping-Pong” on page 565.

Memory Scatter-Gather

When using this mode, the primary control structure for the channel is configured to allow a list of operations (tasks) to be performed. The source address pointer specifies the start of a table of tasks to be copied to the alternate control structure for this channel. The `XFERMODE` field for the alternate control structure should be configured to 0x5 (Alternate memory scatter-gather) to perform the task. When the task completes, the μ DMA switches back to the primary channel control structure, which then copies the next task to the alternate control structure. This process continues until the table of tasks is empty. The last task must have an `XFERMODE` value other than 0x5. Note that for continuous operation, the last task can update the primary channel control structure back to the start of the list or to another list. See “Memory Scatter-Gather” on page 566.

Alternate Memory Scatter-Gather

This value must be used in the alternate channel control data structure when the μ DMA controller operates in Memory Scatter-Gather mode.

Peripheral Scatter-Gather

This value must be used in the primary channel control data structure when the μ DMA controller operates in Peripheral Scatter-Gather mode. In this mode, the μ DMA controller operates exactly the same as in Memory Scatter-Gather mode, except that instead of performing the number of transfers specified by the `XFERSIZE` field in the alternate control structure at one time, the μ DMA controller only performs the number of transfers specified by the `ARBSIZE` field per trigger; see Basic mode for details. See “Peripheral Scatter-Gather” on page 570.

Alternate Peripheral Scatter-Gather

This value must be used in the alternate channel control data structure when the μ DMA controller operates in Peripheral Scatter-Gather mode.

8.6 μ DMA Register Descriptions

The register addresses given are relative to the μ DMA base address of 0x400F.F000.

Register 4: DMA Status (DMASTAT), offset 0x000

The **DMA Status (DMASTAT)** register returns the status of the μ DMA controller. You cannot read this register when the μ DMA controller is in the reset state.

DMA Status (DMASTAT)

Base 0x400F.F000
 Offset 0x000
 Type RO, reset 0x001F.0000

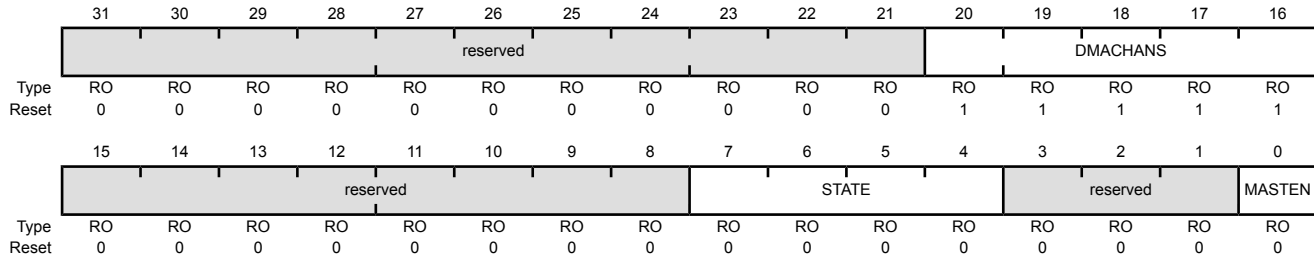

Bit/Field	Name	Type	Reset	Description																								
31:21	reserved	RO	0x000	Software should not rely on the value of a reserved bit. To provide compatibility with future products, the value of a reserved bit should be preserved across a read-modify-write operation.																								
20:16	DMACHANS	RO	0x1F	Available μ DMA Channels Minus 1 This field contains a value equal to the number of μ DMA channels the μ DMA controller is configured to use, minus one. The value of 0x1F corresponds to 32 μ DMA channels.																								
15:8	reserved	RO	0x00	Software should not rely on the value of a reserved bit. To provide compatibility with future products, the value of a reserved bit should be preserved across a read-modify-write operation.																								
7:4	STATE	RO	0x0	Control State Machine Status This field shows the current status of the control state machine. Status can be one of the following. <table border="1"> <thead> <tr> <th>Value</th> <th>Description</th> </tr> </thead> <tbody> <tr><td>0x0</td><td>Idle</td></tr> <tr><td>0x1</td><td>Reading channel controller data.</td></tr> <tr><td>0x2</td><td>Reading source end pointer.</td></tr> <tr><td>0x3</td><td>Reading destination end pointer.</td></tr> <tr><td>0x4</td><td>Reading source data.</td></tr> <tr><td>0x5</td><td>Writing destination data.</td></tr> <tr><td>0x6</td><td>Waiting for μDMA request to clear.</td></tr> <tr><td>0x7</td><td>Writing channel controller data.</td></tr> <tr><td>0x8</td><td>Stalled</td></tr> <tr><td>0x9</td><td>Done</td></tr> <tr><td>0xA-0xF</td><td>Undefined</td></tr> </tbody> </table>	Value	Description	0x0	Idle	0x1	Reading channel controller data.	0x2	Reading source end pointer.	0x3	Reading destination end pointer.	0x4	Reading source data.	0x5	Writing destination data.	0x6	Waiting for μ DMA request to clear.	0x7	Writing channel controller data.	0x8	Stalled	0x9	Done	0xA-0xF	Undefined
Value	Description																											
0x0	Idle																											
0x1	Reading channel controller data.																											
0x2	Reading source end pointer.																											
0x3	Reading destination end pointer.																											
0x4	Reading source data.																											
0x5	Writing destination data.																											
0x6	Waiting for μ DMA request to clear.																											
0x7	Writing channel controller data.																											
0x8	Stalled																											
0x9	Done																											
0xA-0xF	Undefined																											
3:1	reserved	RO	0x0	Software should not rely on the value of a reserved bit. To provide compatibility with future products, the value of a reserved bit should be preserved across a read-modify-write operation.																								

Bit/Field	Name	Type	Reset	Description
0	MASTEN	RO	0	Master Enable Status
				Value Description
				0 The μ DMA controller is disabled.
				1 The μ DMA controller is enabled.

Register 5: DMA Configuration (DMACFG), offset 0x004

The **DMACFG** register controls the configuration of the μ DMA controller.

DMA Configuration (DMACFG)

Base 0x400F.F000

Offset 0x004

Type WO, reset -

	31	30	29	28	27	26	25	24	23	22	21	20	19	18	17	16
	reserved															
Type	WO	WO	WO	WO	WO	WO	WO	WO	WO	WO	WO	WO	WO	WO	WO	WO
Reset	-	-	-	-	-	-	-	-	-	-	-	-	-	-	-	-
	15	14	13	12	11	10	9	8	7	6	5	4	3	2	1	0
	reserved															MASTEN
Type	WO	WO	WO	WO	WO	WO	WO	WO	WO	WO	WO	WO	WO	WO	WO	WO
Reset	-	-	-	-	-	-	-	-	-	-	-	-	-	-	-	-

Bit/Field	Name	Type	Reset	Description
31:1	reserved	WO	-	Software should not rely on the value of a reserved bit. To provide compatibility with future products, the value of a reserved bit should be preserved across a read-modify-write operation.
0	MASTEN	WO	-	Controller Master Enable
				Value Description
				0 Disables the μ DMA controller.
				1 Enables μ DMA controller.

Register 6: DMA Channel Control Base Pointer (DMACTLBASE), offset 0x008

The **DMACTLBASE** register must be configured so that the base pointer points to a location in system memory.

The amount of system memory that must be assigned to the μ DMA controller depends on the number of μ DMA channels used and whether the alternate channel control data structure is used. See “Channel Configuration” on page 563 for details about the Channel Control Table. The base address must be aligned on a 1024-byte boundary. This register cannot be read when the μ DMA controller is in the reset state.

DMA Channel Control Base Pointer (DMACTLBASE)

Base 0x400F.F000

Offset 0x008

Type R/W, reset 0x0000.0000

	31	30	29	28	27	26	25	24	23	22	21	20	19	18	17	16
	ADDR															
Type	R/W	R/W	R/W	R/W	R/W	R/W	R/W	R/W	R/W	R/W	R/W	R/W	R/W	R/W	R/W	R/W
Reset	0	0	0	0	0	0	0	0	0	0	0	0	0	0	0	0
	15	14	13	12	11	10	9	8	7	6	5	4	3	2	1	0
	ADDR						reserved									
Type	R/W	R/W	R/W	R/W	R/W	R/W	RO	RO	RO	RO	RO	RO	RO	RO	RO	RO
Reset	0	0	0	0	0	0	0	0	0	0	0	0	0	0	0	0

Bit/Field	Name	Type	Reset	Description
31:10	ADDR	R/W	0x0000.00	Channel Control Base Address This field contains the pointer to the base address of the channel control table. The base address must be 1024-byte aligned.
9:0	reserved	RO	0x00	Software should not rely on the value of a reserved bit. To provide compatibility with future products, the value of a reserved bit should be preserved across a read-modify-write operation.

Register 7: DMA Alternate Channel Control Base Pointer (DMAALTBASE), offset 0x00C

The **DMAALTBASE** register returns the base address of the alternate channel control data. This register removes the necessity for application software to calculate the base address of the alternate channel control structures. This register cannot be read when the μ DMA controller is in the reset state.

DMA Alternate Channel Control Base Pointer (DMAALTBASE)

Base 0x400F.F000
 Offset 0x00C
 Type RO, reset 0x0000.0200

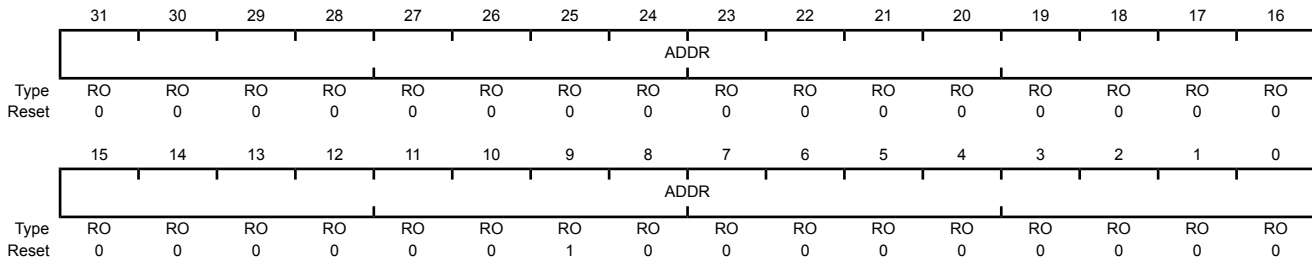

Bit/Field	Name	Type	Reset	Description
31:0	ADDR	RO	0x0000.0200	Alternate Channel Address Pointer This field provides the base address of the alternate channel control structures.

Register 8: DMA Channel Wait-on-Request Status (DMAWAITSTAT), offset 0x010

This read-only register indicates that the μ DMA channel is waiting on a request. A peripheral can hold off the μ DMA from performing a single request until the peripheral is ready for a burst request to enhance the μ DMA performance. The use of this feature is dependent on the design of the peripheral and is not controllable by software in any way. This register cannot be read when the μ DMA controller is in the reset state.

DMA Channel Wait-on-Request Status (DMAWAITSTAT)

Base 0x400F.F000

Offset 0x010

Type RO, reset 0xFFFF.FFC0

	31	30	29	28	27	26	25	24	23	22	21	20	19	18	17	16
	WAITREQ[n]															
Type	RO	RO	RO	RO	RO	RO	RO	RO	RO	RO	RO	RO	RO	RO	RO	RO
Reset	1	1	1	1	1	1	1	1	1	1	1	1	1	1	1	1
	15	14	13	12	11	10	9	8	7	6	5	4	3	2	1	0
	WAITREQ[n]															
Type	RO	RO	RO	RO	RO	RO	RO	RO	RO	RO	RO	RO	RO	RO	RO	RO
Reset	1	1	1	1	1	1	1	1	1	1	0	0	0	0	0	0

Bit/Field	Name	Type	Reset	Description
31:0	WAITREQ[n]	RO	0xFFFF.FFC0	Channel [n] Wait Status These bits provide the channel wait-on-request status. Bit 0 corresponds to channel 0.
				Value Description
				1 The corresponding channel is waiting on a request.
				0 The corresponding channel is not waiting on a request.

Register 9: DMA Channel Software Request (DMASWREQ), offset 0x014

Each bit of the **DMASWREQ** register represents the corresponding μ DMA channel. Setting a bit generates a request for the specified μ DMA channel.

DMA Channel Software Request (DMASWREQ)

Base 0x400F.F000

Offset 0x014

Type WO, reset -

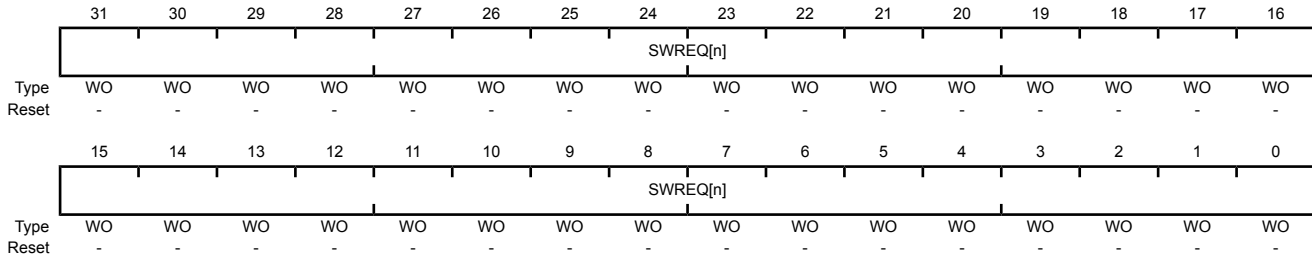

Bit/Field	Name	Type	Reset	Description
31:0	SWREQ[n]	WO	-	<p>Channel [n] Software Request</p> <p>These bits generate software requests. Bit 0 corresponds to channel 0.</p> <p>Value Description</p> <p>1 Generate a software request for the corresponding channel.</p> <p>0 No request generated.</p> <p>These bits are automatically cleared when the software request has been completed.</p>

Register 10: DMA Channel Useburst Set (DMAUSEBURSTSET), offset 0x018

Each bit of the **DMAUSEBURSTSET** register represents the corresponding μ DMA channel. Setting a bit disables the channel's single request input from generating requests, configuring the channel to only accept burst requests. Reading the register returns the status of USEBURST.

If the amount of data to transfer is a multiple of the arbitration (burst) size, the corresponding $SET[n]$ bit is cleared after completing the final transfer. If there are fewer items remaining to transfer than the arbitration (burst) size, the μ DMA controller automatically clears the corresponding $SET[n]$ bit, allowing the remaining items to transfer using single requests. In order to resume transfers using burst requests, the corresponding bit must be set again. A bit should not be set if the corresponding peripheral does not support the burst request model.

Refer to “Request Types” on page 562 for more details about request types.

DMA Channel Useburst Set (DMAUSEBURSTSET)

Base 0x400F.F000
Offset 0x018
Type R/W, reset 0x0000.0000

	31	30	29	28	27	26	25	24	23	22	21	20	19	18	17	16
	SET[n]															
Type	R/W	R/W	R/W	R/W	R/W	R/W	R/W	R/W	R/W	R/W	R/W	R/W	R/W	R/W	R/W	R/W
Reset	0	0	0	0	0	0	0	0	0	0	0	0	0	0	0	0
	15	14	13	12	11	10	9	8	7	6	5	4	3	2	1	0
	SET[n]															
Type	R/W	R/W	R/W	R/W	R/W	R/W	R/W	R/W	R/W	R/W	R/W	R/W	R/W	R/W	R/W	R/W
Reset	0	0	0	0	0	0	0	0	0	0	0	0	0	0	0	0

Bit/Field	Name	Type	Reset	Description
31:0	SET[n]	R/W	0x0000.0000	Channel [n] Useburst Set

Value	Description
0	μ DMA channel [n] responds to single or burst requests.
1	μ DMA channel [n] responds only to burst requests.

Bit 0 corresponds to channel 0. This bit is automatically cleared as described above. A bit can also be manually cleared by setting the corresponding $CLR[n]$ bit in the **DMAUSEBURSTCLR** register.

Register 11: DMA Channel Useburst Clear (DMAUSEBURSTCLR), offset 0x01C

Each bit of the **DMAUSEBURSTCLR** register represents the corresponding μ DMA channel. Setting a bit clears the corresponding **SET[n]** bit in the **DMAUSEBURSTSET** register.

DMA Channel Useburst Clear (DMAUSEBURSTCLR)

Base 0x400F.F000

Offset 0x01C

Type WO, reset -

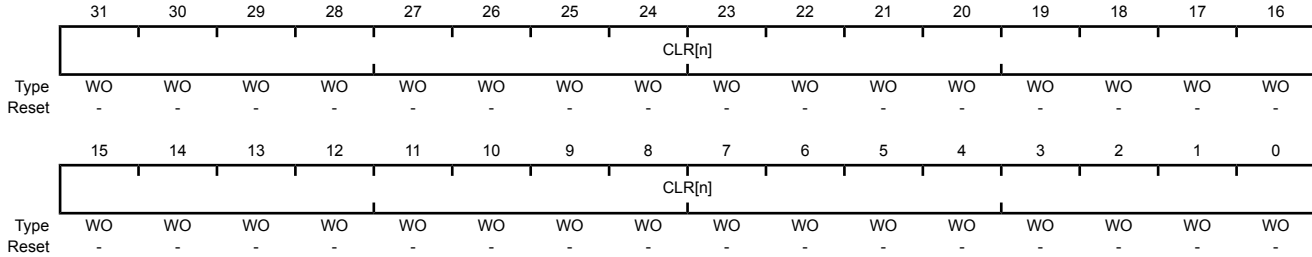

Bit/Field	Name	Type	Reset	Description
31:0	CLR[n]	WO	-	Channel [n] Useburst Clear

Value	Description
0	No effect.
1	Setting a bit clears the corresponding SET[n] bit in the DMAUSEBURSTSET register meaning that μ DMA channel [n] responds to single and burst requests.

Register 12: DMA Channel Request Mask Set (DMAREQMASKSET), offset 0x020

Each bit of the **DMAREQMASKSET** register represents the corresponding μ DMA channel. Setting a bit disables μ DMA requests for the channel. Reading the register returns the request mask status. When a μ DMA channel's request is masked, that means the peripheral can no longer request μ DMA transfers. The channel can then be used for software-initiated transfers.

DMA Channel Request Mask Set (DMAREQMASKSET)

Base 0x400F.F000
Offset 0x020
Type R/W, reset 0x0000.0000

	31	30	29	28	27	26	25	24	23	22	21	20	19	18	17	16
	SET[n]															
Type	R/W	R/W	R/W	R/W	R/W	R/W	R/W	R/W	R/W	R/W	R/W	R/W	R/W	R/W	R/W	R/W
Reset	0	0	0	0	0	0	0	0	0	0	0	0	0	0	0	0
	15	14	13	12	11	10	9	8	7	6	5	4	3	2	1	0
	SET[n]															
Type	R/W	R/W	R/W	R/W	R/W	R/W	R/W	R/W	R/W	R/W	R/W	R/W	R/W	R/W	R/W	R/W
Reset	0	0	0	0	0	0	0	0	0	0	0	0	0	0	0	0

Bit/Field	Name	Type	Reset	Description
31:0	SET[n]	R/W	0x0000.0000	Channel [n] Request Mask Set

Value Description

Value	Description
0	The peripheral associated with channel [n] is enabled to request μ DMA transfers.
1	The peripheral associated with channel [n] is not able to request μ DMA transfers. Channel [n] may be used for software-initiated transfers.

Bit 0 corresponds to channel 0. A bit can only be cleared by setting the corresponding `CLR[n]` bit in the **DMAREQMASKCLR** register.

Register 13: DMA Channel Request Mask Clear (DMAREQMASKCLR), offset 0x024

Each bit of the **DMAREQMASKCLR** register represents the corresponding μ DMA channel. Setting a bit clears the corresponding **SET[n]** bit in the **DMAREQMASKSET** register.

DMA Channel Request Mask Clear (DMAREQMASKCLR)

Base 0x400F.F000

Offset 0x024

Type WO, reset -

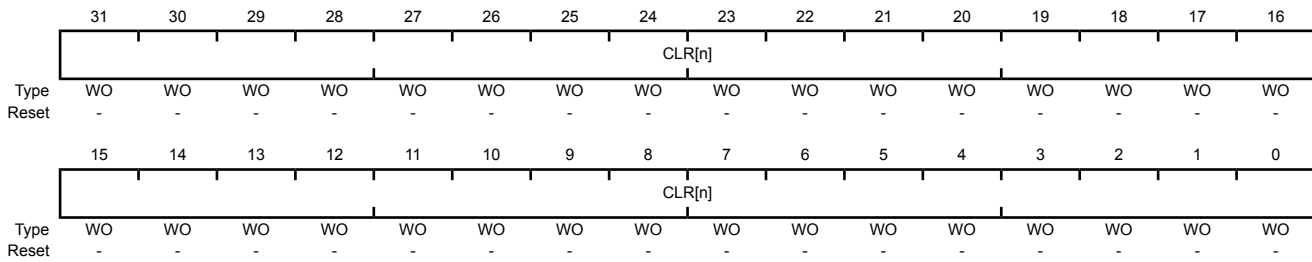

Bit/Field	Name	Type	Reset	Description
31:0	CLR[n]	WO	-	Channel [n] Request Mask Clear

Value Description

- 0 No effect.
- 1 Setting a bit clears the corresponding **SET[n]** bit in the **DMAREQMASKSET** register meaning that the peripheral associated with channel [n] is enabled to request μ DMA transfers.

Register 14: DMA Channel Enable Set (DMAENASET), offset 0x028

Each bit of the **DMAENASET** register represents the corresponding μ DMA channel. Setting a bit enables the corresponding μ DMA channel. Reading the register returns the enable status of the channels. If a channel is enabled but the request mask is set (**DMAREQMASKSET**), then the channel can be used for software-initiated transfers.

DMA Channel Enable Set (DMAENASET)

Base 0x400F.F000
Offset 0x028
Type R/W, reset 0x0000.0000

	31	30	29	28	27	26	25	24	23	22	21	20	19	18	17	16
	SET[n]															
Type	R/W	R/W	R/W	R/W	R/W	R/W	R/W	R/W	R/W	R/W	R/W	R/W	R/W	R/W	R/W	R/W
Reset	0	0	0	0	0	0	0	0	0	0	0	0	0	0	0	0
	15	14	13	12	11	10	9	8	7	6	5	4	3	2	1	0
	SET[n]															
Type	R/W	R/W	R/W	R/W	R/W	R/W	R/W	R/W	R/W	R/W	R/W	R/W	R/W	R/W	R/W	R/W
Reset	0	0	0	0	0	0	0	0	0	0	0	0	0	0	0	0

Bit/Field	Name	Type	Reset	Description
31:0	SET[n]	R/W	0x0000.0000	Channel [n] Enable Set

Value	Description
0	μ DMA Channel [n] is disabled.
1	μ DMA Channel [n] is enabled.

Bit 0 corresponds to channel 0. A bit can only be cleared by setting the corresponding **CLR[n]** bit in the **DMAENACL** register or when the end of a μ DMA transfer occurs.

Register 15: DMA Channel Enable Clear (DMAENACLRL), offset 0x02C

Each bit of the **DMAENACLRL** register represents the corresponding μ DMA channel. Setting a bit clears the corresponding **SET[n]** bit in the **DMAENASET** register.

DMA Channel Enable Clear (DMAENACLRL)

Base 0x400F.F000

Offset 0x02C

Type WO, reset -

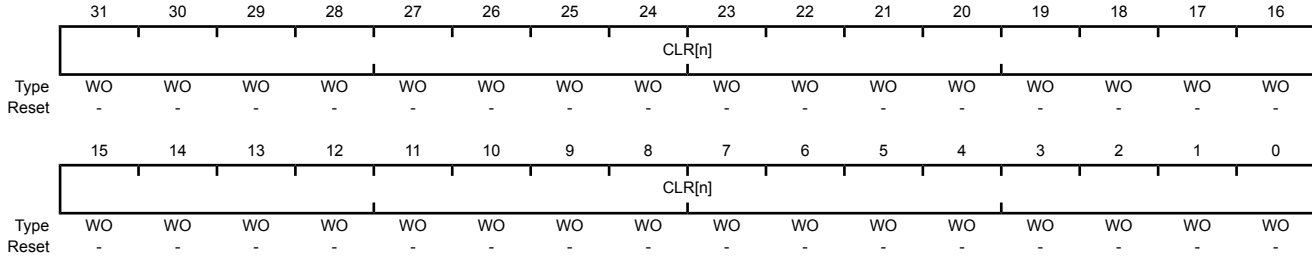

Bit/Field	Name	Type	Reset	Description
31:0	CLR[n]	WO	-	Clear Channel [n] Enable Clear

Value	Description
0	No effect.
1	Setting a bit clears the corresponding SET[n] bit in the DMAENASET register meaning that channel [n] is disabled for μ DMA transfers.

Note: The controller disables a channel when it completes the μ DMA cycle.

Register 16: DMA Channel Primary Alternate Set (DMAALTSET), offset 0x030

Each bit of the **DMAALTSET** register represents the corresponding μ DMA channel. Setting a bit configures the μ DMA channel to use the alternate control data structure. Reading the register returns the status of which control data structure is in use for the corresponding μ DMA channel.

DMA Channel Primary Alternate Set (DMAALTSET)

Base 0x400F.F000
Offset 0x030
Type R/W, reset 0x0000.0000

	31	30	29	28	27	26	25	24	23	22	21	20	19	18	17	16
	SET[n]															
Type	R/W	R/W	R/W	R/W	R/W	R/W	R/W	R/W	R/W	R/W	R/W	R/W	R/W	R/W	R/W	R/W
Reset	0	0	0	0	0	0	0	0	0	0	0	0	0	0	0	0
	15	14	13	12	11	10	9	8	7	6	5	4	3	2	1	0
	SET[n]															
Type	R/W	R/W	R/W	R/W	R/W	R/W	R/W	R/W	R/W	R/W	R/W	R/W	R/W	R/W	R/W	R/W
Reset	0	0	0	0	0	0	0	0	0	0	0	0	0	0	0	0

Bit/Field	Name	Type	Reset	Description
31:0	SET[n]	R/W	0x0000.0000	Channel [n] Alternate Set

Value Description

0	μ DMA channel [n] is using the primary control structure.
1	μ DMA channel [n] is using the alternate control structure.

Bit 0 corresponds to channel 0. A bit can only be cleared by setting the corresponding CLR[n] bit in the **DMAALTCLR** register.

Note: For Ping-Pong and Scatter-Gather cycle types, the μ DMA controller automatically sets these bits to select the alternate channel control data structure.

Register 17: DMA Channel Primary Alternate Clear (DMAALTCLR), offset 0x034

Each bit of the **DMAALTCLR** register represents the corresponding μ DMA channel. Setting a bit clears the corresponding **SET[n]** bit in the **DMAALTSET** register.

DMA Channel Primary Alternate Clear (DMAALTCLR)

Base 0x400F.F000

Offset 0x034

Type WO, reset -

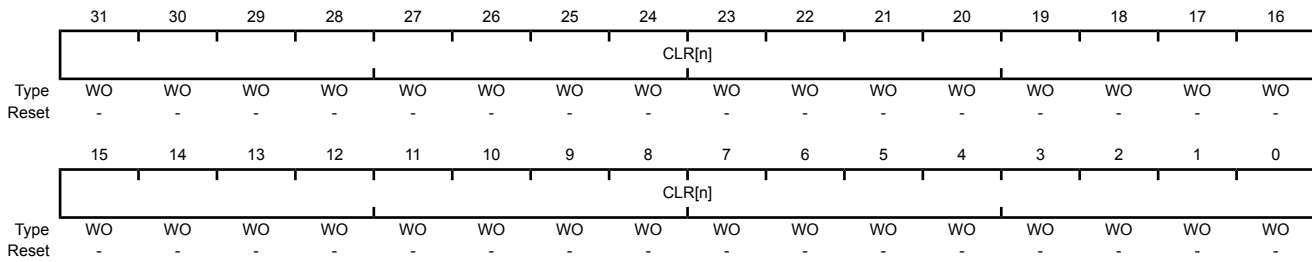

Bit/Field	Name	Type	Reset	Description
31:0	CLR[n]	WO	-	Channel [n] Alternate Clear

Value	Description
0	No effect.
1	Setting a bit clears the corresponding SET[n] bit in the DMAALTSET register meaning that channel [n] is using the primary control structure.

Note: For Ping-Pong and Scatter-Gather cycle types, the μ DMA controller automatically sets these bits to select the alternate channel control data structure.

Register 18: DMA Channel Priority Set (DMAPRIOSET), offset 0x038

Each bit of the **DMAPRIOSET** register represents the corresponding μ DMA channel. Setting a bit configures the μ DMA channel to have a high priority level. Reading the register returns the status of the channel priority mask.

DMA Channel Priority Set (DMAPRIOSET)

Base 0x400F.F000
Offset 0x038
Type R/W, reset 0x0000.0000

	31	30	29	28	27	26	25	24	23	22	21	20	19	18	17	16
	SET[n]															
Type	R/W	R/W	R/W	R/W	R/W	R/W	R/W	R/W	R/W	R/W	R/W	R/W	R/W	R/W	R/W	R/W
Reset	0	0	0	0	0	0	0	0	0	0	0	0	0	0	0	0
	15	14	13	12	11	10	9	8	7	6	5	4	3	2	1	0
	SET[n]															
Type	R/W	R/W	R/W	R/W	R/W	R/W	R/W	R/W	R/W	R/W	R/W	R/W	R/W	R/W	R/W	R/W
Reset	0	0	0	0	0	0	0	0	0	0	0	0	0	0	0	0

Bit/Field	Name	Type	Reset	Description
31:0	SET[n]	R/W	0x0000.0000	Channel [n] Priority Set

Value Description

- 0 μ DMA channel [n] is using the default priority level.
- 1 μ DMA channel [n] is using a high priority level.

Bit 0 corresponds to channel 0. A bit can only be cleared by setting the corresponding CLR[n] bit in the **DMAPRIOCLR** register.

Register 19: DMA Channel Priority Clear (DMPRIOCLR), offset 0x03C

Each bit of the **DMPRIOCLR** register represents the corresponding μ DMA channel. Setting a bit clears the corresponding **SET[n]** bit in the **DMPRIOSET** register.

DMA Channel Priority Clear (DMPRIOCLR)

Base 0x400F.F000

Offset 0x03C

Type WO, reset -

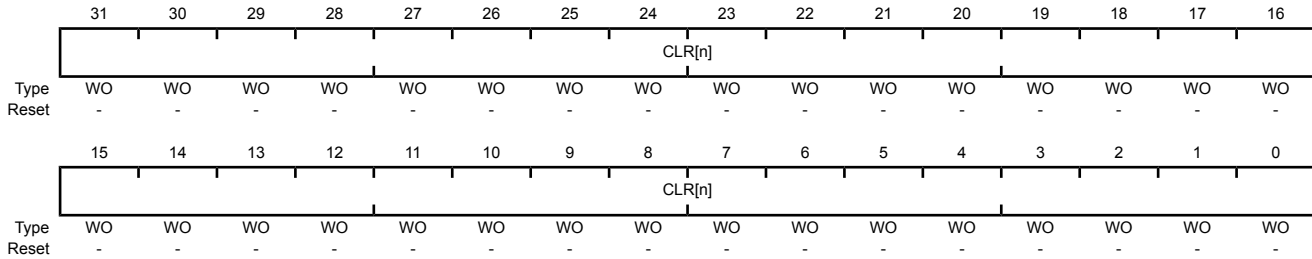

Bit/Field	Name	Type	Reset	Description
31:0	CLR[n]	WO	-	Channel [n] Priority Clear
				Value Description
				0 No effect.
				1 Setting a bit clears the corresponding SET[n] bit in the DMPRIOSET register meaning that channel [n] is using the default priority level.

Register 20: DMA Bus Error Clear (DMAERRCLR), offset 0x04C

The **DMAERRCLR** register is used to read and clear the μ DMA bus error status. The error status is set if the μ DMA controller encountered a bus error while performing a transfer. If a bus error occurs on a channel, that channel is automatically disabled by the μ DMA controller. The other channels are unaffected.

DMA Bus Error Clear (DMAERRCLR)

Base 0x400F.F000
Offset 0x04C
Type R/W, reset 0x0000.0000

	31	30	29	28	27	26	25	24	23	22	21	20	19	18	17	16
	reserved															
Type	RO	RO	RO	RO	RO	RO	RO	RO	RO	RO	RO	RO	RO	RO	RO	RO
Reset	0	0	0	0	0	0	0	0	0	0	0	0	0	0	0	0
	15	14	13	12	11	10	9	8	7	6	5	4	3	2	1	0
	reserved															ERRCLR
Type	RO	RO	RO	RO	RO	RO	RO	RO	RO	RO	RO	RO	RO	RO	RO	R/W1C
Reset	0	0	0	0	0	0	0	0	0	0	0	0	0	0	0	0

Bit/Field	Name	Type	Reset	Description
31:1	reserved	RO	0x0000.000	Software should not rely on the value of a reserved bit. To provide compatibility with future products, the value of a reserved bit should be preserved across a read-modify-write operation.
0	ERRCLR	R/W1C	0	μ DMA Bus Error Status
				Value Description
				0 No bus error is pending.
				1 A bus error is pending.
				This bit is cleared by writing a 1 to it.

Register 21: DMA Channel Assignment (DMACHASGN), offset 0x500

Each bit of the **DMACHASGN** register represents the corresponding μ DMA channel. Setting a bit selects the secondary channel assignment as specified in Table 8-1 on page 561.

Note: This register is provided to support legacy software. New software should use the **DMACHMAPn** registers. If a bit is clear in this register, the corresponding field in the **DMACHMAPn** registers is configured to 0x0. If a bit is set in this register, the corresponding field is configured to 0x1. If this register is read, a bit reads as 0 if the corresponding **DMACHMAPn** register field value is equal to 0, otherwise it reads as 1 if the corresponding **DMACHMAPn** register field value is not equal to 0.

DMA Channel Assignment (DMACHASGN)

Base 0x400F.F000
 Offset 0x500
 Type R/W, reset 0x0000.0000

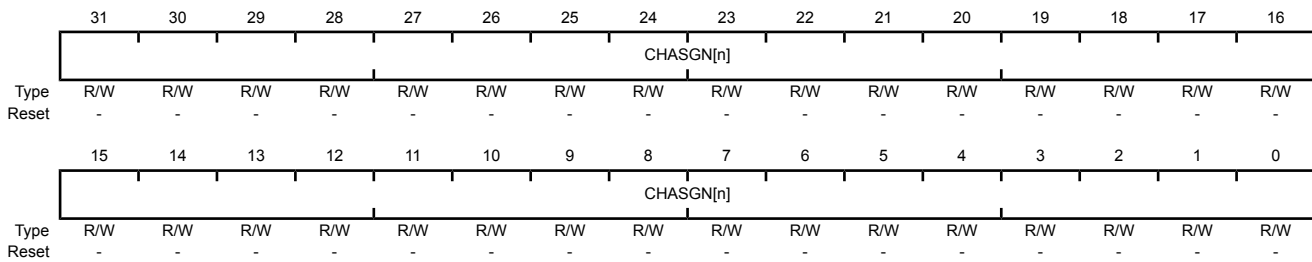

Bit/Field	Name	Type	Reset	Description
31:0	CHASGN[n]	R/W	-	Channel [n] Assignment Select
				Value Description
				0 Use the primary channel assignment.
				1 Use the secondary channel assignment.

Register 22: DMA Channel Interrupt Status (DMACHIS), offset 0x504

Each bit of the **DMACHIS** register represents the corresponding μ DMA channel. A bit is set when that μ DMA channel causes a completion interrupt. The bits are cleared by a writing a 1.

DMA Channel Interrupt Status (DMACHIS)

Base 0x400F.F000

Offset 0x504

Type R/W1C, reset 0x0000.0000

	31	30	29	28	27	26	25	24	23	22	21	20	19	18	17	16
	CHIS[n]															
Type	R/W1C	R/W1C	R/W1C	R/W1C	R/W1C	R/W1C	R/W1C	R/W1C	R/W1C	R/W1C	R/W1C	R/W1C	R/W1C	R/W1C	R/W1C	R/W1C
Reset	0	0	0	0	0	0	0	0	0	0	0	0	0	0	0	0
	15	14	13	12	11	10	9	8	7	6	5	4	3	2	1	0
	CHIS[n]															
Type	R/W1C	R/W1C	R/W1C	R/W1C	R/W1C	R/W1C	R/W1C	R/W1C	R/W1C	R/W1C	R/W1C	R/W1C	R/W1C	R/W1C	R/W1C	R/W1C
Reset	0	0	0	0	0	0	0	0	0	0	0	0	0	0	0	0

Bit/Field	Name	Type	Reset	Description
31:0	CHIS[n]	R/W1C	0x0000.0000	Channel [n] Interrupt Status

Value Description

1 The corresponding μ DMA channel caused an interrupt.

0 The corresponding μ DMA channel has not caused an interrupt.

This bit is cleared by writing a 1 to it.

Register 23: DMA Channel Map Select 0 (DMACHMAP0), offset 0x510

Each 4-bit field of the **DMACHMAP0** register configures the μ DMA channel assignment as specified in Table 8-1 on page 561.

Note: To support legacy software which uses the **DMA Channel Assignment (DMACHASGN)** register, a value of 0x0 is equivalent to a **DMACHASGN** bit being clear, and a value of 0x1 is equivalent to a **DMACHASGN** bit being set.

DMA Channel Map Select 0 (DMACHMAP0)

Base 0x400F.F000
Offset 0x510
Type R/W, reset 0x0000.0000

	31	30	29	28	27	26	25	24	23	22	21	20	19	18	17	16
	CH7SEL				CH6SEL				CH5SEL				CH4SEL			
Type	R/W	R/W	R/W	R/W	R/W	R/W	R/W	R/W	R/W	R/W	R/W	R/W	R/W	R/W	R/W	R/W
Reset	0	0	0	0	0	0	0	0	0	0	0	0	0	0	0	0
	15	14	13	12	11	10	9	8	7	6	5	4	3	2	1	0
	CH3SEL				CH2SEL				CH1SEL				CH0SEL			
Type	R/W	R/W	R/W	R/W	R/W	R/W	R/W	R/W	R/W	R/W	R/W	R/W	R/W	R/W	R/W	R/W
Reset	0	0	0	0	0	0	0	0	0	0	0	0	0	0	0	0

Bit/Field	Name	Type	Reset	Description
31:28	CH7SEL	R/W	0x00	μ DMA Channel 7 Source Select See Table 8-1 on page 561 for channel assignments.
27:24	CH6SEL	R/W	0x00	μ DMA Channel 6 Source Select See Table 8-1 on page 561 for channel assignments.
23:20	CH5SEL	R/W	0x00	μ DMA Channel 5 Source Select See Table 8-1 on page 561 for channel assignments.
19:16	CH4SEL	R/W	0x00	μ DMA Channel 4 Source Select See Table 8-1 on page 561 for channel assignments.
15:12	CH3SEL	R/W	0x00	μ DMA Channel 3 Source Select See Table 8-1 on page 561 for channel assignments.
11:8	CH2SEL	R/W	0x00	μ DMA Channel 2 Source Select See Table 8-1 on page 561 for channel assignments.
7:4	CH1SEL	R/W	0x00	μ DMA Channel 1 Source Select See Table 8-1 on page 561 for channel assignments.
3:0	CH0SEL	R/W	0x00	μ DMA Channel 0 Source Select See Table 8-1 on page 561 for channel assignments.

Register 24: DMA Channel Map Select 1 (DMACHMAP1), offset 0x514

Each 4-bit field of the **DMACHMAP1** register configures the μ DMA channel assignment as specified in Table 8-1 on page 561.

Note: To support legacy software which uses the **DMA Channel Assignment (DMACHASGN)** register, a value of 0x0 is equivalent to a **DMACHASGN** bit being clear, and a value of 0x1 is equivalent to a **DMACHASGN** bit being set.

DMA Channel Map Select 1 (DMACHMAP1)

Base 0x400F.F000

Offset 0x514

Type R/W, reset 0x0000.0000

	31	30	29	28	27	26	25	24	23	22	21	20	19	18	17	16
	CH15SEL				CH14SEL				CH13SEL				CH12SEL			
Type	R/W	R/W	R/W	R/W	R/W	R/W	R/W	R/W	R/W	R/W	R/W	R/W	R/W	R/W	R/W	R/W
Reset	0	0	0	0	0	0	0	0	0	0	0	0	0	0	0	0
	15	14	13	12	11	10	9	8	7	6	5	4	3	2	1	0
	CH11SEL				CH10SEL				CH9SEL				CH8SEL			
Type	R/W	R/W	R/W	R/W	R/W	R/W	R/W	R/W	R/W	R/W	R/W	R/W	R/W	R/W	R/W	R/W
Reset	0	0	0	0	0	0	0	0	0	0	0	0	0	0	0	0

Bit/Field	Name	Type	Reset	Description
31:28	CH15SEL	R/W	0x00	μ DMA Channel 15 Source Select See Table 8-1 on page 561 for channel assignments.
27:24	CH14SEL	R/W	0x00	μ DMA Channel 14 Source Select See Table 8-1 on page 561 for channel assignments.
23:20	CH13SEL	R/W	0x00	μ DMA Channel 13 Source Select See Table 8-1 on page 561 for channel assignments.
19:16	CH12SEL	R/W	0x00	μ DMA Channel 12 Source Select See Table 8-1 on page 561 for channel assignments.
15:12	CH11SEL	R/W	0x00	μ DMA Channel 11 Source Select See Table 8-1 on page 561 for channel assignments.
11:8	CH10SEL	R/W	0x00	μ DMA Channel 10 Source Select See Table 8-1 on page 561 for channel assignments.
7:4	CH9SEL	R/W	0x00	μ DMA Channel 9 Source Select See Table 8-1 on page 561 for channel assignments.
3:0	CH8SEL	R/W	0x00	μ DMA Channel 8 Source Select See Table 8-1 on page 561 for channel assignments.

Register 25: DMA Channel Map Select 2 (DMACHMAP2), offset 0x518

Each 4-bit field of the **DMACHMAP2** register configures the μDMA channel assignment as specified in Table 8-1 on page 561.

Note: To support legacy software which uses the **DMA Channel Assignment (DMACHASGN)** register, a value of 0x0 is equivalent to a **DMACHASGN** bit being clear, and a value of 0x1 is equivalent to a **DMACHASGN** bit being set.

DMA Channel Map Select 2 (DMACHMAP2)

Base 0x400F.F000
 Offset 0x518
 Type R/W, reset 0x0000.0000

	31	30	29	28	27	26	25	24	23	22	21	20	19	18	17	16
	CH23SEL				CH22SEL				CH21SEL				CH20SEL			
Type	R/W	R/W	R/W	R/W	R/W	R/W	R/W	R/W	R/W	R/W	R/W	R/W	R/W	R/W	R/W	R/W
Reset	0	0	0	0	0	0	0	0	0	0	0	0	0	0	0	0
	15	14	13	12	11	10	9	8	7	6	5	4	3	2	1	0
	CH19SEL				CH18SEL				CH17SEL				CH16SEL			
Type	R/W	R/W	R/W	R/W	R/W	R/W	R/W	R/W	R/W	R/W	R/W	R/W	R/W	R/W	R/W	R/W
Reset	0	0	0	0	0	0	0	0	0	0	0	0	0	0	0	0

Bit/Field	Name	Type	Reset	Description
31:28	CH23SEL	R/W	0x00	μDMA Channel 23 Source Select See Table 8-1 on page 561 for channel assignments.
27:24	CH22SEL	R/W	0x00	μDMA Channel 22 Source Select See Table 8-1 on page 561 for channel assignments.
23:20	CH21SEL	R/W	0x00	μDMA Channel 21 Source Select See Table 8-1 on page 561 for channel assignments.
19:16	CH20SEL	R/W	0x00	μDMA Channel 20 Source Select See Table 8-1 on page 561 for channel assignments.
15:12	CH19SEL	R/W	0x00	μDMA Channel 19 Source Select See Table 8-1 on page 561 for channel assignments.
11:8	CH18SEL	R/W	0x00	μDMA Channel 18 Source Select See Table 8-1 on page 561 for channel assignments.
7:4	CH17SEL	R/W	0x00	μDMA Channel 17 Source Select See Table 8-1 on page 561 for channel assignments.
3:0	CH16SEL	R/W	0x00	μDMA Channel 16 Source Select See Table 8-1 on page 561 for channel assignments.

Register 26: DMA Channel Map Select 3 (DMACHMAP3), offset 0x51C

Each 4-bit field of the **DMACHMAP3** register configures the μ DMA channel assignment as specified in Table 8-1 on page 561.

Note: To support legacy software which uses the **DMA Channel Assignment (DMACHASGN)** register, a value of 0x0 is equivalent to a **DMACHASGN** bit being clear, and a value of 0x1 is equivalent to a **DMACHASGN** bit being set.

DMA Channel Map Select 3 (DMACHMAP3)

Base 0x400F.F000
Offset 0x51C
Type R/W, reset 0x0000.0000

	31	30	29	28	27	26	25	24	23	22	21	20	19	18	17	16
	CH31SEL				CH30SEL				CH29SEL				CH28SEL			
Type	R/W	R/W	R/W	R/W	R/W	R/W	R/W	R/W	R/W	R/W	R/W	R/W	R/W	R/W	R/W	R/W
Reset	0	0	0	0	0	0	0	0	0	0	0	0	0	0	0	0
	15	14	13	12	11	10	9	8	7	6	5	4	3	2	1	0
	CH27SEL				CH26SEL				CH25SEL				CH24SEL			
Type	R/W	R/W	R/W	R/W	R/W	R/W	R/W	R/W	R/W	R/W	R/W	R/W	R/W	R/W	R/W	R/W
Reset	0	0	0	0	0	0	0	0	0	0	0	0	0	0	0	0

Bit/Field	Name	Type	Reset	Description
31:28	CH31SEL	R/W	0x00	μ DMA Channel 31 Source Select See Table 8-1 on page 561 for channel assignments.
27:24	CH30SEL	R/W	0x00	μ DMA Channel 30 Source Select See Table 8-1 on page 561 for channel assignments.
23:20	CH29SEL	R/W	0x00	μ DMA Channel 29 Source Select See Table 8-1 on page 561 for channel assignments.
19:16	CH28SEL	R/W	0x00	μ DMA Channel 28 Source Select See Table 8-1 on page 561 for channel assignments.
15:12	CH27SEL	R/W	0x00	μ DMA Channel 27 Source Select See Table 8-1 on page 561 for channel assignments.
11:8	CH26SEL	R/W	0x00	μ DMA Channel 26 Source Select See Table 8-1 on page 561 for channel assignments.
7:4	CH25SEL	R/W	0x00	μ DMA Channel 25 Source Select See Table 8-1 on page 561 for channel assignments.
3:0	CH24SEL	R/W	0x00	μ DMA Channel 24 Source Select See Table 8-1 on page 561 for channel assignments.

Register 27: DMA Peripheral Identification 0 (DMAPeriphID0), offset 0xFE0

The **DMAPeriphIDn** registers are hard-coded, and the fields within the registers determine the reset values.

DMA Peripheral Identification 0 (DMAPeriphID0)

Base 0x400F.F000

Offset 0xFE0

Type RO, reset 0x0000.0030

	31	30	29	28	27	26	25	24	23	22	21	20	19	18	17	16
	reserved															
Type	RO	RO	RO	RO	RO	RO	RO	RO	RO	RO	RO	RO	RO	RO	RO	RO
Reset	0	0	0	0	0	0	0	0	0	0	0	0	0	0	0	0
	15	14	13	12	11	10	9	8	7	6	5	4	3	2	1	0
	reserved								PID0							
Type	RO	RO	RO	RO	RO	RO	RO	RO	RO	RO	RO	RO	RO	RO	RO	RO
Reset	0	0	0	0	0	0	0	0	0	0	1	1	0	0	0	0

Bit/Field	Name	Type	Reset	Description
31:8	reserved	RO	0x0000.00	Software should not rely on the value of a reserved bit. To provide compatibility with future products, the value of a reserved bit should be preserved across a read-modify-write operation.
7:0	PID0	RO	0x30	μ DMA Peripheral ID Register [7:0] Can be used by software to identify the presence of this peripheral.

Register 28: DMA Peripheral Identification 1 (DMAPeriphID1), offset 0xFE4

The **DMAPeriphIDn** registers are hard-coded, and the fields within the registers determine the reset values.

DMA Peripheral Identification 1 (DMAPeriphID1)

Base 0x400F.F000

Offset 0xFE4

Type RO, reset 0x0000.00B2

	31	30	29	28	27	26	25	24	23	22	21	20	19	18	17	16
	reserved															
Type	RO	RO	RO	RO	RO	RO	RO	RO	RO	RO	RO	RO	RO	RO	RO	RO
Reset	0	0	0	0	0	0	0	0	0	0	0	0	0	0	0	0
	15	14	13	12	11	10	9	8	7	6	5	4	3	2	1	0
	reserved								PID1							
Type	RO	RO	RO	RO	RO	RO	RO	RO	RO	RO	RO	RO	RO	RO	RO	RO
Reset	0	0	0	0	0	0	0	0	1	0	1	1	0	0	1	0

Bit/Field	Name	Type	Reset	Description
31:8	reserved	RO	0x0000.00	Software should not rely on the value of a reserved bit. To provide compatibility with future products, the value of a reserved bit should be preserved across a read-modify-write operation.
7:0	PID1	RO	0xB2	μDMA Peripheral ID Register [15:8] Can be used by software to identify the presence of this peripheral.

Register 29: DMA Peripheral Identification 2 (DMAPeriphID2), offset 0xFE8

The **DMAPeriphIDn** registers are hard-coded, and the fields within the registers determine the reset values.

DMA Peripheral Identification 2 (DMAPeriphID2)

Base 0x400F.F000
 Offset 0xFE8
 Type RO, reset 0x0000.000B

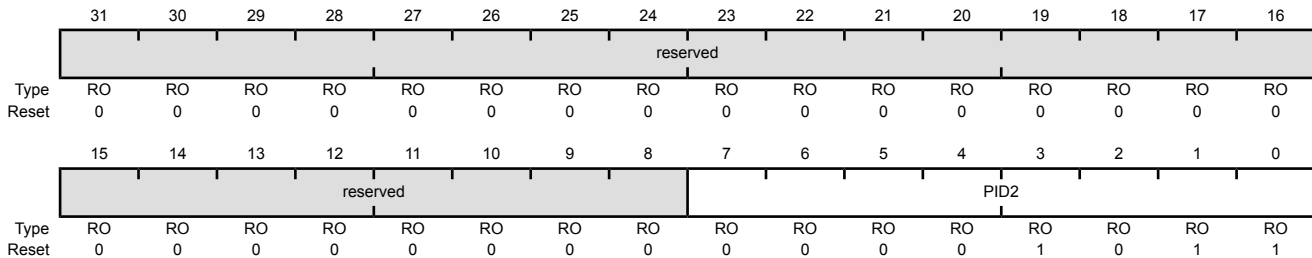

Bit/Field	Name	Type	Reset	Description
31:8	reserved	RO	0x0000.00	Software should not rely on the value of a reserved bit. To provide compatibility with future products, the value of a reserved bit should be preserved across a read-modify-write operation.
7:0	PID2	RO	0x0B	μ DMA Peripheral ID Register [23:16] Can be used by software to identify the presence of this peripheral.

Register 30: DMA Peripheral Identification 3 (DMAPeriphID3), offset 0xFEC

The **DMAPeriphIDn** registers are hard-coded and the fields within the registers determine the reset values.

DMA Peripheral Identification 3 (DMAPeriphID3)

Base 0x400F.F000

Offset 0xFEC

Type RO, reset 0x0000.0000

	31	30	29	28	27	26	25	24	23	22	21	20	19	18	17	16
	reserved															
Type	RO	RO	RO	RO	RO	RO	RO	RO	RO	RO	RO	RO	RO	RO	RO	RO
Reset	0	0	0	0	0	0	0	0	0	0	0	0	0	0	0	0
	15	14	13	12	11	10	9	8	7	6	5	4	3	2	1	0
	reserved								PID3							
Type	RO	RO	RO	RO	RO	RO	RO	RO	RO	RO	RO	RO	RO	RO	RO	RO
Reset	0	0	0	0	0	0	0	0	0	0	0	0	0	0	0	0

Bit/Field	Name	Type	Reset	Description
31:8	reserved	RO	0x0000.00	Software should not rely on the value of a reserved bit. To provide compatibility with future products, the value of a reserved bit should be preserved across a read-modify-write operation.
7:0	PID3	RO	0x00	μDMA Peripheral ID Register [31:24] Can be used by software to identify the presence of this peripheral.

Register 31: DMA Peripheral Identification 4 (DMAPeriphID4), offset 0xFD0

The **DMAPeriphIDn** registers are hard-coded, and the fields within the registers determine the reset values.

DMA Peripheral Identification 4 (DMAPeriphID4)

Base 0x400F.F000
 Offset 0xFD0
 Type RO, reset 0x0000.0004

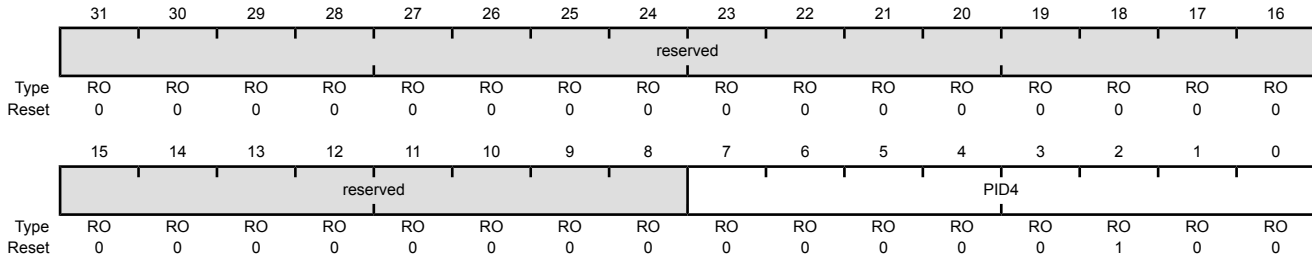

Bit/Field	Name	Type	Reset	Description
31:8	reserved	RO	0x0000.00	Software should not rely on the value of a reserved bit. To provide compatibility with future products, the value of a reserved bit should be preserved across a read-modify-write operation.
7:0	PID4	RO	0x04	μ DMA Peripheral ID Register Can be used by software to identify the presence of this peripheral.

Register 32: DMA PrimeCell Identification 0 (DMAPCellID0), offset 0xFF0

The **DMAPCellIDn** registers are hard-coded, and the fields within the registers determine the reset values.

DMA PrimeCell Identification 0 (DMAPCellID0)

Base 0x400F.F000

Offset 0xFF0

Type RO, reset 0x0000.000D

	31	30	29	28	27	26	25	24	23	22	21	20	19	18	17	16
	reserved															
Type	RO	RO	RO	RO	RO	RO	RO	RO	RO	RO	RO	RO	RO	RO	RO	RO
Reset	0	0	0	0	0	0	0	0	0	0	0	0	0	0	0	0
	15	14	13	12	11	10	9	8	7	6	5	4	3	2	1	0
	reserved								CID0							
Type	RO	RO	RO	RO	RO	RO	RO	RO	RO	RO	RO	RO	RO	RO	RO	RO
Reset	0	0	0	0	0	0	0	0	0	0	0	0	1	1	0	1

Bit/Field	Name	Type	Reset	Description
31:8	reserved	RO	0x0000.00	Software should not rely on the value of a reserved bit. To provide compatibility with future products, the value of a reserved bit should be preserved across a read-modify-write operation.
7:0	CID0	RO	0x0D	μDMA PrimeCell ID Register [7:0] Provides software a standard cross-peripheral identification system.

Register 33: DMA PrimeCell Identification 1 (DMAPCellID1), offset 0xFF4

The **DMAPCellIDn** registers are hard-coded, and the fields within the registers determine the reset values.

DMA PrimeCell Identification 1 (DMAPCellID1)

Base 0x400F.F000

Offset 0xFF4

Type RO, reset 0x0000.00F0

	31	30	29	28	27	26	25	24	23	22	21	20	19	18	17	16
	reserved															
Type	RO	RO	RO	RO	RO	RO	RO	RO	RO	RO	RO	RO	RO	RO	RO	RO
Reset	0	0	0	0	0	0	0	0	0	0	0	0	0	0	0	0
	15	14	13	12	11	10	9	8	7	6	5	4	3	2	1	0
	reserved								CID1							
Type	RO	RO	RO	RO	RO	RO	RO	RO	RO	RO	RO	RO	RO	RO	RO	RO
Reset	0	0	0	0	0	0	0	0	1	1	1	1	0	0	0	0

Bit/Field	Name	Type	Reset	Description
31:8	reserved	RO	0x0000.00	Software should not rely on the value of a reserved bit. To provide compatibility with future products, the value of a reserved bit should be preserved across a read-modify-write operation.
7:0	CID1	RO	0xF0	μ DMA PrimeCell ID Register [15:8] Provides software a standard cross-peripheral identification system.

Register 34: DMA PrimeCell Identification 2 (DMAPCellID2), offset 0xFF8

The **DMAPCellIDn** registers are hard-coded, and the fields within the registers determine the reset values.

DMA PrimeCell Identification 2 (DMAPCellID2)

Base 0x400F.F000

Offset 0xFF8

Type RO, reset 0x0000.0005

	31	30	29	28	27	26	25	24	23	22	21	20	19	18	17	16
	reserved															
Type	RO	RO	RO	RO	RO	RO	RO	RO	RO	RO	RO	RO	RO	RO	RO	RO
Reset	0	0	0	0	0	0	0	0	0	0	0	0	0	0	0	0
	15	14	13	12	11	10	9	8	7	6	5	4	3	2	1	0
	reserved								CID2							
Type	RO	RO	RO	RO	RO	RO	RO	RO	RO	RO	RO	RO	RO	RO	RO	RO
Reset	0	0	0	0	0	0	0	0	0	0	0	0	0	1	0	1

Bit/Field	Name	Type	Reset	Description
31:8	reserved	RO	0x00	Software should not rely on the value of a reserved bit. To provide compatibility with future products, the value of a reserved bit should be preserved across a read-modify-write operation.
7:0	CID2	RO	0x05	μDMA PrimeCell ID Register [23:16] Provides software a standard cross-peripheral identification system.

Register 35: DMA PrimeCell Identification 3 (DMAPCellID3), offset 0xFFC

The **DMAPCellIDn** registers are hard-coded, and the fields within the registers determine the reset values.

DMA PrimeCell Identification 3 (DMAPCellID3)

Base 0x400F.F000
 Offset 0xFFC
 Type RO, reset 0x0000.00B1

	31	30	29	28	27	26	25	24	23	22	21	20	19	18	17	16
	reserved															
Type	RO	RO	RO	RO	RO	RO	RO	RO	RO	RO	RO	RO	RO	RO	RO	RO
Reset	0	0	0	0	0	0	0	0	0	0	0	0	0	0	0	0
	15	14	13	12	11	10	9	8	7	6	5	4	3	2	1	0
	reserved								CID3							
Type	RO	RO	RO	RO	RO	RO	RO	RO	RO	RO	RO	RO	RO	RO	RO	RO
Reset	0	0	0	0	0	0	0	0	1	0	1	1	0	0	0	1

Bit/Field	Name	Type	Reset	Description
31:8	reserved	RO	0x00	Software should not rely on the value of a reserved bit. To provide compatibility with future products, the value of a reserved bit should be preserved across a read-modify-write operation.
7:0	CID3	RO	0xB1	μ DMA PrimeCell ID Register [31:24] Provides software a standard cross-peripheral identification system.

9 General-Purpose Input/Outputs (GPIOs)

The GPIO module is composed of seven physical GPIO blocks, each corresponding to an individual GPIO port (Port A, Port B, Port C, Port D, Port E, Port F, Port G). The GPIO module supports up to 49 programmable input/output pins, depending on the peripherals being used.

The GPIO module has the following features:

- Up to 49 GPIOs, depending on configuration
- Highly flexible pin muxing allows use as GPIO or one of several peripheral functions
- 5-V-tolerant in input configuration
- Two means of port access: either Advanced High-Performance Bus (AHB) with better back-to-back access performance, or the legacy Advanced Peripheral Bus (APB) for backwards-compatibility with existing code for Ports A-G
- Fast toggle capable of a change every clock cycle for ports on AHB, every two clock cycles for ports on APB
- Programmable control for GPIO interrupts
 - Interrupt generation masking
 - Edge-triggered on rising, falling, or both
 - Level-sensitive on High or Low values
- Bit masking in both read and write operations through address lines
- Can be used to initiate an ADC sample sequence or a μ DMA transfer
- Pins configured as digital inputs are Schmitt-triggered
- Programmable control for GPIO pad configuration
 - Weak pull-up or pull-down resistors
 - 2-mA, 4-mA, and 8-mA pad drive for digital communication; up to four pads can sink 18-mA for high-current applications
 - Slew rate control for 8-mA pad drive
 - Open drain enables
 - Digital input enables

9.1 Signal Description

GPIO signals have alternate hardware functions. The following table lists the GPIO pins and their analog and digital alternate functions. All GPIO signals are 5-V tolerant when configured as inputs except for `PB0` and `PB1`, which are limited to 3.6 V. The digital alternate hardware functions are enabled by setting the appropriate bit in the **GPIO Alternate Function Select (GPIOAFSEL)** and **GPIODEN** registers and configuring the `PMCx` bit field in the **GPIO Port Control (GPIOPCTL)**

register to the numeric encoding shown in the table below. Analog signals in the table below are also 5-V tolerant and are configured by clearing the DEN bit in the **GPIO Digital Enable (GPIO DEN)** register. The AIN_x analog signals have internal circuitry to protect them from voltages over V_{DD} (up to the maximum specified in Table 24-1 on page 1322), but analog performance specifications are only guaranteed if the input signal swing at the I/O pad is kept inside the range 0 V < V_{IN} < V_{DD}. Note that each pin must be programmed individually; no type of grouping is implied by the columns in the table. Table entries that are shaded gray are the default values for the corresponding GPIO pin.

Important: All GPIO pins are configured as GPIOs and tri-stated by default (**GPIOAFSEL=0**, **GPIO DEN=0**, **GPIO PDR=0**, **GPIO PUR=0**, and **GPIO PCTL=0**), with the exception of the pins shown in the table below. A Power-On-Reset (POR) or asserting RST puts the pins back to their default state.

Table 9-1. GPIO Pins With Non-Zero Reset Values

GPIO Pins	Default State	GPIOAFSEL	GPIO DEN	GPIO PDR	GPIO PUR	GPIO PCTL
PA[1:0]	UART0	0	0	0	0	0x1
PA[5:2]	SSI0	0	0	0	0	0x2
PB[3:2]	I ² C0	0	0	0	0	0x3
PC[3:0]	JTAG/SWD	1	1	0	1	0x1

The GPIO commit control registers provide a layer of protection against accidental programming of critical hardware signals including the GPIO pins that can function as JTAG/SWD signals and the NMI signal. The commit control process must be followed for these pins, even if they are programmed as alternate functions other than JTAG/SWD or NMI, see “Commit Control” on page 630.

Table 9-2. GPIO Pins and Alternate Functions (64LQFP)

IO	Pin	Analog Function	Digital Function (GPIO PCTL PMCx Bit Field Encoding) ^a											
			1	2	3	4	5	6	7	8	9	14	15	
PA0	17	-	U0Rx	-	-	-	-	-	-	-	CAN1Rx	-	-	-
PA1	18	-	U0Tx	-	-	-	-	-	-	-	CAN1Tx	-	-	-
PA2	19	-	-	SSI0Clk	-	-	-	-	-	-	-	-	-	-
PA3	20	-	-	SSI0Fss	-	-	-	-	-	-	-	-	-	-
PA4	21	-	-	SSI0Rx	-	-	-	-	-	-	-	-	-	-
PA5	22	-	-	SSI0Tx	-	-	-	-	-	-	-	-	-	-
PA6	23	-	-	-	I2C1SCL	-	M1PWM2	-	-	-	-	-	-	-
PA7	24	-	-	-	I2C1SDA	-	M1PWM3	-	-	-	-	-	-	-
PB0	45	USB0ID	U1Rx	-	-	-	-	-	-	T2CCP0	-	-	-	-
PB1	46	USB0VBUS	U1Tx	-	-	-	-	-	-	T2CCP1	-	-	-	-
PB2	47	-	-	-	I2C0SCL	-	-	-	-	T3CCP0	-	-	-	-
PB3	48	-	-	-	I2C0SDA	-	-	-	-	T3CCP1	-	-	-	-
PB4	58	AIN10	-	SSI2Clk	-	M0PWM2	-	-	-	T1CCP0	CAN0Rx	-	-	-
PB5	57	AIN11	-	SSI2Fss	-	M0PWM3	-	-	-	T1CCP1	CAN0Tx	-	-	-
PB6	1	-	-	SSI2Rx	I2C5SCL	M0PWM0	-	-	-	T0CCP0	-	-	-	-
PB7	4	-	-	SSI2Tx	I2C5SDA	M0PWM1	-	-	-	T0CCP1	-	-	-	-

Table 9-2. GPIO Pins and Alternate Functions (64LQFP) (continued)

IO	Pin	Analog Function	Digital Function (GPIOCTL PMCx Bit Field Encoding) ^a											
			1	2	3	4	5	6	7	8	9	14	15	
PC0	52	-	TCK SWCLK	-	-	-	-	-	-	T4CCP0	-	-	-	-
PC1	51	-	TMS SWDIO	-	-	-	-	-	-	T4CCP1	-	-	-	-
PC2	50	-	TDI	-	-	-	-	-	-	T5CCP0	-	-	-	-
PC3	49	-	TDO SWO	-	-	-	-	-	-	T5CCP1	-	-	-	-
PC4	16	C1-	U4Rx	U1Rx	-	M0PWM6	-	IDX1	WT0CCP0	U1RTS	-	-	-	-
PC5	15	C1+	U4Tx	U1Tx	-	M0PWM7	-	PhA1	WT0CCP1	U1CTS	-	-	-	-
PC6	14	C0+	U3Rx	-	-	-	-	PhB1	WT1CCP0	USB0EPEN	-	-	-	-
PC7	13	C0-	U3Tx	-	-	-	-	-	WT1CCP1	USB0PFLT	-	-	-	-
PD0	61	AIN7	SSI3Clk	SSI1Clk	I2C3SCL	M0PWM6	M1PWM0	-	WT2CCP0	-	-	-	-	-
PD1	62	AIN6	SSI3Fss	SSI1Fss	I2C3SDA	M0PWM7	M1PWM1	-	WT2CCP1	-	-	-	-	-
PD2	63	AIN5	SSI3Rx	SSI1Rx	-	M0FAULT0	-	-	WT3CCP0	USB0EPEN	-	-	-	-
PD3	64	AIN4	SSI3Tx	SSI1Tx	-	-	-	IDX0	WT3CCP1	USB0PFLT	-	-	-	-
PD4	43	USB0DM	U6Rx	-	-	-	-	-	WT4CCP0	-	-	-	-	-
PD5	44	USB0DP	U6Tx	-	-	-	-	-	WT4CCP1	-	-	-	-	-
PD6	53	-	U2Rx	-	-	M0FAULT0	-	PhA0	WT5CCP0	-	-	-	-	-
PD7	10	-	U2Tx	-	-	M0FAULT1	-	PhB0	WT5CCP1	NMI	-	-	-	-
PE0	9	AIN3	U7Rx	-	-	-	-	-	-	-	-	-	-	-
PE1	8	AIN2	U7Tx	-	-	-	-	-	-	-	-	-	-	-
PE2	7	AIN1	-	-	-	-	-	-	-	-	-	-	-	-
PE3	6	AIN0	-	-	-	-	-	-	-	-	-	-	-	-
PE4	59	AIN9	U5Rx	-	I2C2SCL	M0PWM4	M1PWM2	-	-	CAN0Rx	-	-	-	-
PE5	60	AIN8	U5Tx	-	I2C2SDA	M0PWM5	M1PWM3	-	-	CAN0Tx	-	-	-	-
PF0	28	-	U1RTS	SSI1Rx	CAN0Rx	-	M1PWM4	PhA0	T0CCP0	NMI	C0o	-	-	-
PF1	29	-	U1CTS	SSI1Tx	-	-	M1PWM5	PhB0	T0CCP1	-	C1o	TRD1	-	-
PF2	30	-	-	SSI1Clk	-	M0FAULT0	M1PWM6	-	T1CCP0	-	-	TRD0	-	-
PF3	31	-	-	SSI1Fss	CAN0Tx	M0FAULT1	M1PWM7	-	T1CCP1	-	-	TRCLK	-	-
PF4	5	-	-	-	-	M0FAULT2	M1FAULT0	IDX0	T2CCP0	USB0EPEN	-	-	-	-
PG0	37	-	-	-	I2C3SCL	-	M1FAULT1	PhA1	T4CCP0	-	-	-	-	-
PG1	36	-	-	-	I2C3SDA	-	M1FAULT2	PhB1	T4CCP1	-	-	-	-	-
PG2	35	-	-	-	I2C4SCL	M0FAULT1	M1PWM0	-	T5CCP0	-	-	-	-	-
PG3	34	-	-	-	I2C4SDA	M0FAULT2	M1PWM1	PhA1	T5CCP1	-	-	-	-	-
PG4	33	-	U2Rx	-	I2C1SCL	M0PWM4	M1PWM2	PhB1	WT0CCP0	USB0EPEN	-	-	-	-
PG5	32	-	U2Tx	-	I2C1SDA	M0PWM5	M1PWM3	IDX1	WT0CCP1	USB0PFLT	-	-	-	-

a. The digital signals that are shaded gray are the power-on default values for the corresponding GPIO pin. Encodings 10-13 are not used on this device.

9.2 Functional Description

Each GPIO port is a separate hardware instantiation of the same physical block (see Figure 9-1 on page 626 and Figure 9-2 on page 627). The LM4F231H5QR microcontroller contains seven

ports and thus seven of these physical GPIO blocks. Note that not all pins are implemented on every block. Some GPIO pins can function as I/O signals for the on-chip peripheral modules. For information on which GPIO pins are used for alternate hardware functions, refer to Table 22-5 on page 1314.

Figure 9-1. Digital I/O Pads

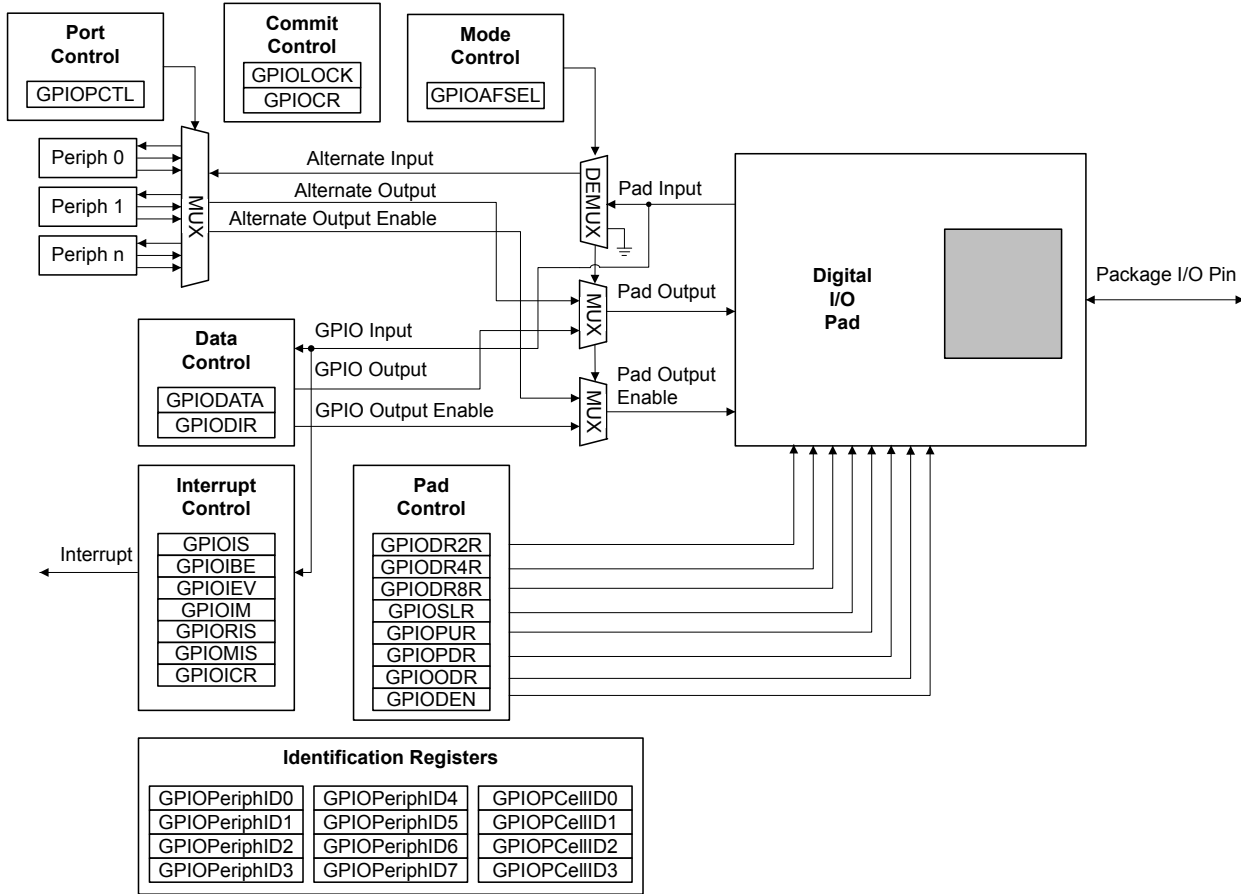
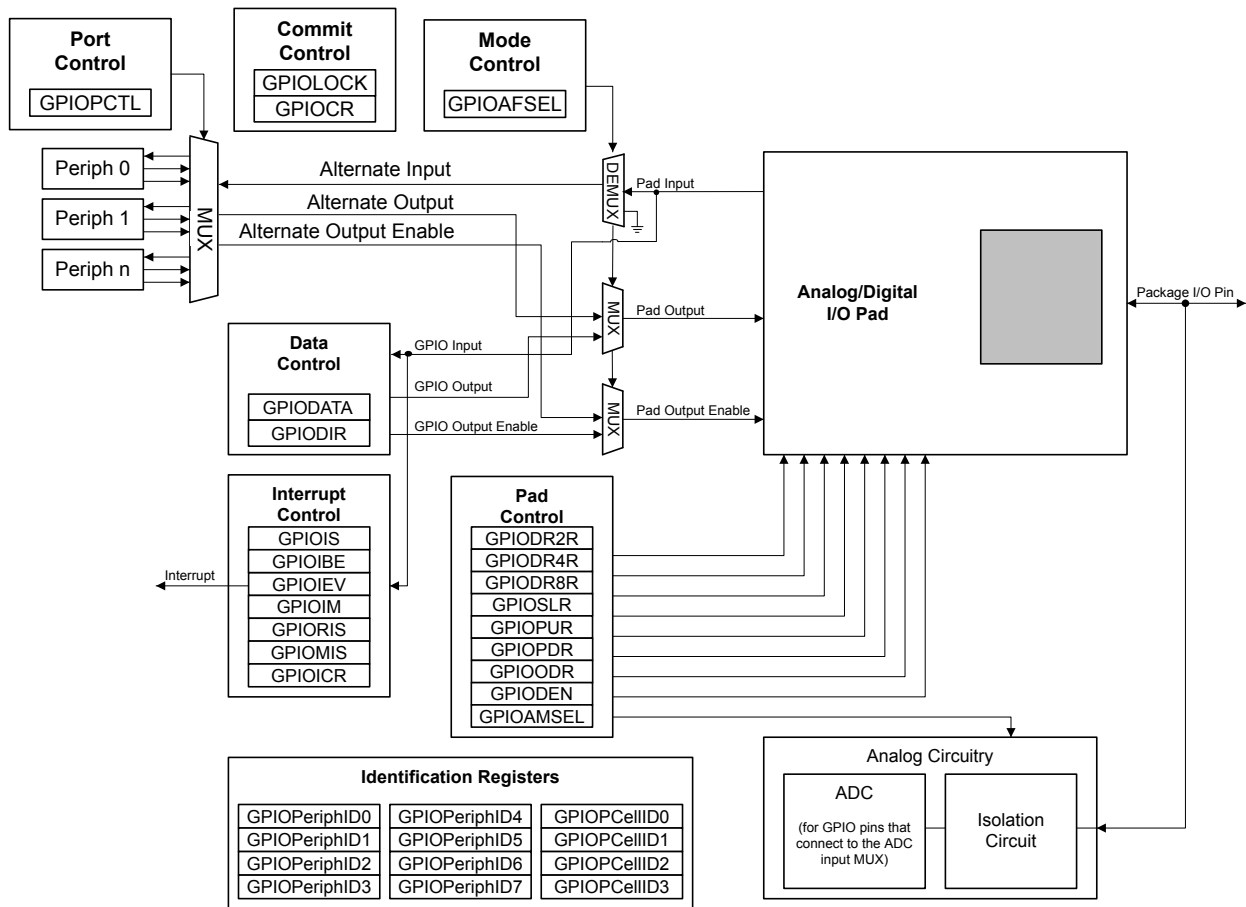

Figure 9-2. Analog/Digital I/O Pads



9.2.1 Data Control

The data control registers allow software to configure the operational modes of the GPIOs. The data direction register configures the GPIO as an input or an output while the data register either captures incoming data or drives it out to the pads.

Caution – It is possible to create a software sequence that prevents the debugger from connecting to the Stellaris® microcontroller. If the program code loaded into flash immediately changes the JTAG pins to their GPIO functionality, the debugger may not have enough time to connect and halt the controller before the JTAG pin functionality switches. As a result, the debugger may be locked out of the part. This issue can be avoided with a software routine that restores JTAG functionality based on an external or software trigger.

9.2.1.1 Data Direction Operation

The **GPIO Direction (GPIODIR)** register (see page 636) is used to configure each individual pin as an input or output. When the data direction bit is cleared, the GPIO is configured as an input, and the corresponding data register bit captures and stores the value on the GPIO port. When the data direction bit is set, the GPIO is configured as an output, and the corresponding data register bit is driven out on the GPIO port.

9.2.1.2 Data Register Operation

To aid in the efficiency of software, the GPIO ports allow for the modification of individual bits in the **GPIO Data (GPIODATA)** register (see page 635) by using bits [9:2] of the address bus as a mask. In this manner, software drivers can modify individual GPIO pins in a single instruction without affecting the state of the other pins. This method is more efficient than the conventional method of performing a read-modify-write operation to set or clear an individual GPIO pin. To implement this feature, the **GPIODATA** register covers 256 locations in the memory map.

During a write, if the address bit associated with that data bit is set, the value of the **GPIODATA** register is altered. If the address bit is cleared, the data bit is left unchanged.

For example, writing a value of 0xEB to the address GPIODATA + 0x098 has the results shown in Figure 9-3, where u indicates that data is unchanged by the write.

Figure 9-3. GPIODATA Write Example

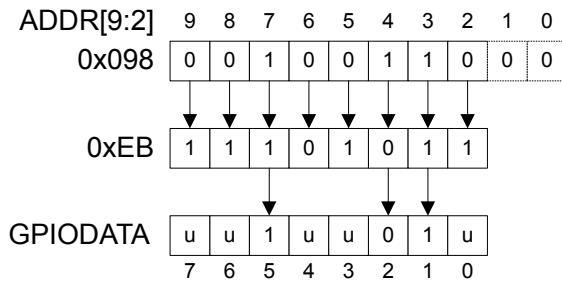

During a read, if the address bit associated with the data bit is set, the value is read. If the address bit associated with the data bit is cleared, the data bit is read as a zero, regardless of its actual value. For example, reading address GPIODATA + 0x0C4 yields as shown in Figure 9-4.

Figure 9-4. GPIODATA Read Example

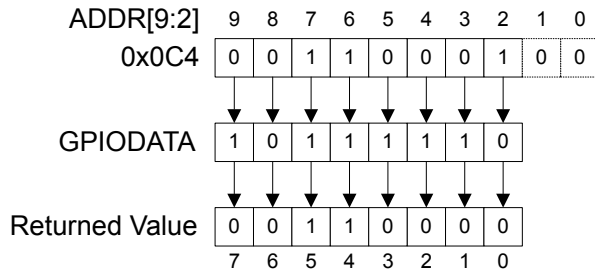

9.2.2 Interrupt Control

The interrupt capabilities of each GPIO port are controlled by a set of seven registers. These registers are used to select the source of the interrupt, its polarity, and the edge properties. When one or more GPIO inputs cause an interrupt, a single interrupt output is sent to the interrupt controller for the entire GPIO port. For edge-triggered interrupts, software must clear the interrupt to enable any further interrupts. For a level-sensitive interrupt, the external source must hold the level constant for the interrupt to be recognized by the controller.

Three registers define the edge or sense that causes interrupts:

- **GPIO Interrupt Sense (GPIOIS)** register (see page 637)

- **GPIO Interrupt Both Edges (GPIOIBE)** register (see page 638)
- **GPIO Interrupt Event (GPIOIEV)** register (see page 639)

Interrupts are enabled/disabled via the **GPIO Interrupt Mask (GPIOIM)** register (see page 640).

When an interrupt condition occurs, the state of the interrupt signal can be viewed in two locations: the **GPIO Raw Interrupt Status (GPIORIS)** and **GPIO Masked Interrupt Status (GPIOMIS)** registers (see page 641 and page 642). As the name implies, the **GPIOMIS** register only shows interrupt conditions that are allowed to be passed to the interrupt controller. The **GPIORIS** register indicates that a GPIO pin meets the conditions for an interrupt, but has not necessarily been sent to the interrupt controller.

Interrupts are cleared by writing a 1 to the appropriate bit of the **GPIO Interrupt Clear (GPIOICR)** register (see page 643).

When programming the interrupt control registers (**GPIOIS**, **GPIOIBE**, or **GPIOIEV**), the interrupts should be masked (**GPIOIM** cleared). Writing any value to an interrupt control register can generate a spurious interrupt if the corresponding bits are enabled.

9.2.2.1 ADC Trigger Source

Any GPIO pin can be configured to be an external trigger for the ADC using the **GPIO ADC Control (GPIOADCCTL)** register. If any GPIO is configured as a non-masked interrupt pin (the appropriate bit of **GPIOIM** is set), and an interrupt for that port is generated, a trigger signal is sent to the ADC. If the **ADC Event Multiplexer Select (ADCEMUX)** register is configured to use the external trigger, an ADC conversion is initiated. See page 803.

Note that if the Port B **GPIOADCCTL** register is cleared, PB4 can still be used as an external trigger for the ADC. This is a legacy mode which allows code written for previous Stellaris devices to operate on this microcontroller.

9.2.2.2 μ DMA Trigger Source

Any GPIO pin can be configured to be an external trigger for the μ DMA using the **GPIO DMA Control (GPIODMACTL)** register. If any GPIO is configured as a non-masked interrupt pin (the appropriate bit of **GPIOIM** is set), an interrupt for that port is generated and an external trigger signal is sent to the μ DMA. A `dma_req` signal is sent to the μ DMA. If the μ DMA is configured to start a transfer based on the GPIO signal, a transfer is initiated. When transfer is complete, the `dma_done` signal is sent from the μ DMA to the GPIO and is reported as a DMA (done) interrupt in the **GPIORIS** register.

9.2.3 Mode Control

The GPIO pins can be controlled by either software or hardware. Software control is the default for most signals and corresponds to the GPIO mode, where the **GPIODATA** register is used to read or write the corresponding pins. When hardware control is enabled via the **GPIO Alternate Function Select (GPIOAFSEL)** register (see page 644), the pin state is controlled by its alternate function (that is, the peripheral).

Further pin muxing options are provided through the **GPIO Port Control (GPIOPCTL)** register which selects one of several peripheral functions for each GPIO. For information on the configuration options, refer to Table 22-5 on page 1314.

Note: If any pin is to be used as an ADC input, the appropriate bit in the **GPIOAMSEL** register must be set to disable the analog isolation circuit.

9.2.4 Commit Control

The GPIO commit control registers provide a layer of protection against accidental programming of critical hardware peripherals. Protection is provided for the GPIO pins that can be used as the four JTAG/SWD pins ($PC[3:0]$) and the NMI pin ($PD7$ and $PF0$). Writes to protected bits of the **GPIO Alternate Function Select (GPIOAFSEL)** register (see page 644), **GPIO Pull Up Select (GPIOPUR)** register (see page 650), **GPIO Pull-Down Select (GPIOPDR)** register (see page 652), and **GPIO Digital Enable (GPIODEN)** register (see page 655) are not committed to storage unless the **GPIO Lock (GPIOLOCK)** register (see page 657) has been unlocked and the appropriate bits of the **GPIO Commit (GPIOCR)** register (see page 658) have been set.

9.2.5 Pad Control

The pad control registers allow software to configure the GPIO pads based on the application requirements. The pad control registers include the **GPIODR2R**, **GPIODR4R**, **GPIODR8R**, **GPIODR**, **GPIOPUR**, **GPIOPDR**, **GPIOSLR**, and **GPIODEN** registers. These registers control drive strength, open-drain configuration, pull-up and pull-down resistors, slew-rate control and digital input enable for each GPIO.

9.2.6 Identification

The identification registers configured at reset allow software to detect and identify the module as a GPIO block. The identification registers include the **GPIOPeriphID0-GPIOPeriphID7** registers as well as the **GPIOCellID0-GPIOCellID3** registers.

9.3 Initialization and Configuration

The GPIO modules may be accessed via two different memory apertures. The legacy aperture, the Advanced Peripheral Bus (APB), is backwards-compatible with previous Stellaris parts. The other aperture, the Advanced High-Performance Bus (AHB), offers the same register map but provides better back-to-back access performance than the APB bus. These apertures are mutually exclusive. The aperture enabled for a given GPIO port is controlled by the appropriate bit in the **GPIOHBCTL** register (see page 254). Note that GPIO can only be accessed through the AHB aperture.

To use the pins in a particular GPIO port, the clock for the port must be enabled by setting the appropriate GPIO Port bit field ($GPIO_n$) in the **RCGCGPIO** register (see page 319).

When the internal POR signal is asserted and until otherwise configured, all GPIO pins are configured to be undriven (tristate): **GPIOAFSEL=0**, **GPIODEN=0**, **GPIOPDR=0**, and **GPIOPUR=0**, except for the pins shown in Table 9-1 on page 624. Table 9-3 on page 630 shows all possible configurations of the GPIO pads and the control register settings required to achieve them. Table 9-4 on page 631 shows how a rising edge interrupt is configured for pin 2 of a GPIO port.

Table 9-3. GPIO Pad Configuration Examples

Configuration	GPIO Register Bit Value ^a									
	AFSEL	DIR	ODR	DEN	PUR	PDR	DR2R	DR4R	DR8R	SLR
Digital Input (GPIO)	0	0	0	1	?	?	X	X	X	X
Digital Output (GPIO)	0	1	0	1	?	?	?	?	?	?
Open Drain Output (GPIO)	0	1	1	1	X	X	?	?	?	?
Open Drain Input/Output (I2CSDA)	1	X	1	1	X	X	?	?	?	?
Digital Input (Timer CCP)	1	X	0	1	?	?	X	X	X	X

Table 9-3. GPIO Pad Configuration Examples (continued)

Configuration	GPIO Register Bit Value ^a									
	AFSEL	DIR	ODR	DEN	PUR	PDR	DR2R	DR4R	DR8R	SLR
Digital Input (QEI)	1	X	0	1	?	?	X	X	X	X
Digital Output (PWM)	1	X	0	1	?	?	?	?	?	?
Digital Output (Timer PWM)	1	X	0	1	?	?	?	?	?	?
Digital Input/Output (SSI)	1	X	0	1	?	?	?	?	?	?
Digital Input/Output (UART)	1	X	0	1	?	?	?	?	?	?
Analog Input (Comparator)	0	0	0	0	0	0	X	X	X	X
Digital Output (Comparator)	1	X	0	1	?	?	?	?	?	?

a. X=Ignored (don't care bit)

?=Can be either 0 or 1, depending on the configuration

Table 9-4. GPIO Interrupt Configuration Example

Register	Desired Interrupt Event Trigger	Pin 2 Bit Value ^a							
		7	6	5	4	3	2	1	0
GPIOIS	0=edge 1=level	X	X	X	X	X	0	X	X
GPIOIBE	0=single edge 1=both edges	X	X	X	X	X	0	X	X
GPIOIEV	0=Low level, or falling edge 1=High level, or rising edge	X	X	X	X	X	1	X	X
GPIOIM	0=masked 1=not masked	0	0	0	0	0	1	0	0

a. X=Ignored (don't care bit)

9.4 Register Map

Table 9-6 on page 632 lists the GPIO registers. Each GPIO port can be accessed through one of two bus apertures. The legacy aperture, the Advanced Peripheral Bus (APB), is backwards-compatible with previous Stellaris parts. The other aperture, the Advanced High-Performance Bus (AHB), offers the same register map but provides better back-to-back access performance than the APB bus.

Important: The GPIO registers in this chapter are duplicated in each GPIO block; however, depending on the block, all eight bits may not be connected to a GPIO pad. In those cases, writing to unconnected bits has no effect, and reading unconnected bits returns no meaningful data.

The offset listed is a hexadecimal increment to the register's address, relative to that GPIO port's base address:

- GPIO Port A (APB): 0x4000.4000
- GPIO Port A (AHB): 0x4005.8000

- GPIO Port B (APB): 0x4000.5000
- GPIO Port B (AHB): 0x4005.9000
- GPIO Port C (APB): 0x4000.6000
- GPIO Port C (AHB): 0x4005.A000
- GPIO Port D (APB): 0x4000.7000
- GPIO Port D (AHB): 0x4005.B000
- GPIO Port E (APB): 0x4002.4000
- GPIO Port E (AHB): 0x4005.C000
- GPIO Port F (APB): 0x4002.5000
- GPIO Port F (AHB): 0x4005.D000
- GPIO Port G (APB): 0x4002.6000
- GPIO Port G (AHB): 0x4005.E000

Note that each GPIO module clock must be enabled before the registers can be programmed (see page 319). There must be a delay of 3 system clocks after the GPIO module clock is enabled before any GPIO module registers are accessed.

Important: All GPIO pins are configured as GPIOs and tri-stated by default (**GPIOAFSEL=0**, **GPIODEN=0**, **GPIOPDR=0**, **GPIOPUR=0**, and **GPIOPCTL=0**), with the exception of the pins shown in the table below. A Power-On-Reset (\overline{POR}) or asserting \overline{RST} puts the pins back to their default state.

Table 9-5. GPIO Pins With Non-Zero Reset Values

GPIO Pins	Default State	GPIOAFSEL	GPIODEN	GPIOPDR	GPIOPUR	GPIOPCTL
PA[1:0]	UART0	0	0	0	0	0x1
PA[5:2]	SSIO	0	0	0	0	0x2
PB[3:2]	I ² C0	0	0	0	0	0x3
PC[3:0]	JTAG/SWD	1	1	0	1	0x1

The GPIO commit control registers provide a layer of protection against accidental programming of critical hardware signals including the GPIO pins that can function as JTAG/SWD signals and the NMI signal. The commit control process must be followed for these pins, even if they are programmed as alternate functions other than JTAG/SWD or NMI, see “Commit Control” on page 630.

The default register type for the **GPIOCR** register is RO for all GPIO pins with the exception of the **NMI** pin and the four JTAG/SWD pins (**PD7**, **PF0**, and **PC[3:0]**). These six pins are the only GPIOs that are protected by the **GPIOCR** register. Because of this, the register type for GPIO Port D7, GPIO Port F0, and GPIO Port C[3:0] is R/W.

The default reset value for the **GPIOCR** register is 0x0000.00FF for all GPIO pins, with the exception of the **NMI** pin and the four JTAG/SWD pins (**PD7**, **PF0**, and **PC[3:0]**). To ensure that the JTAG port is not accidentally programmed as GPIO pins, the **PC[3:0]** pins default to non-committable. Similarly, to ensure that the **NMI** pin is not accidentally programmed as a GPIO pin, the **PD7** and **PF0** pins default to non-committable. Because of this, the default reset value of **GPIOCR** for GPIO Port C is 0x0000.00F0, for GPIO Port D is 0x0000.007F, and for GPIO Port F is 0x0000.00FE.

Table 9-6. GPIO Register Map

Offset	Name	Type	Reset	Description	See page
0x000	GPIODATA	R/W	0x0000.0000	GPIO Data	635

Table 9-6. GPIO Register Map (continued)

Offset	Name	Type	Reset	Description	See page
0x400	GPDIR	R/W	0x0000.0000	GPIO Direction	636
0x404	GPIOIS	R/W	0x0000.0000	GPIO Interrupt Sense	637
0x408	GPIOIBE	R/W	0x0000.0000	GPIO Interrupt Both Edges	638
0x40C	GPIOIEV	R/W	0x0000.0000	GPIO Interrupt Event	639
0x410	GPIOIM	R/W	0x0000.0000	GPIO Interrupt Mask	640
0x414	GPORIS	RO	0x0000.0000	GPIO Raw Interrupt Status	641
0x418	GPOMIS	RO	0x0000.0000	GPIO Masked Interrupt Status	642
0x41C	GPIOICR	W1C	0x0000.0000	GPIO Interrupt Clear	643
0x420	GPIOAFSEL	R/W	-	GPIO Alternate Function Select	644
0x500	GPIDR2R	R/W	0x0000.00FF	GPIO 2-mA Drive Select	646
0x504	GPIDR4R	R/W	0x0000.0000	GPIO 4-mA Drive Select	647
0x508	GPIDR8R	R/W	0x0000.0000	GPIO 8-mA Drive Select	648
0x50C	GPIOODR	R/W	0x0000.0000	GPIO Open Drain Select	649
0x510	GPPOPUR	R/W	-	GPIO Pull-Up Select	650
0x514	GPPOPDR	R/W	0x0000.0000	GPIO Pull-Down Select	652
0x518	GPPOSLR	R/W	0x0000.0000	GPIO Slew Rate Control Select	654
0x51C	GPPODEN	R/W	-	GPIO Digital Enable	655
0x520	GPPOLOCK	R/W	0x0000.0001	GPIO Lock	657
0x524	GPPOCR	-	-	GPIO Commit	658
0x528	GPPOAMSEL	R/W	0x0000.0000	GPIO Analog Mode Select	660
0x52C	GPPOPCTL	R/W	-	GPIO Port Control	661
0x530	GPPOADCCTL	R/W	0x0000.0000	GPIO ADC Control	663
0x534	GPPODMACTL	R/W	0x0000.0000	GPIO DMA Control	664
0xFD0	GPPOPeriphID4	RO	0x0000.0000	GPIO Peripheral Identification 4	665
0xFD4	GPPOPeriphID5	RO	0x0000.0000	GPIO Peripheral Identification 5	666
0xFD8	GPPOPeriphID6	RO	0x0000.0000	GPIO Peripheral Identification 6	667
0xFDC	GPPOPeriphID7	RO	0x0000.0000	GPIO Peripheral Identification 7	668
0xFE0	GPPOPeriphID0	RO	0x0000.0061	GPIO Peripheral Identification 0	669
0xFE4	GPPOPeriphID1	RO	0x0000.0000	GPIO Peripheral Identification 1	670
0xFE8	GPPOPeriphID2	RO	0x0000.0018	GPIO Peripheral Identification 2	671
0xFEC	GPPOPeriphID3	RO	0x0000.0001	GPIO Peripheral Identification 3	672
0xFF0	GPPOPCellID0	RO	0x0000.000D	GPIO PrimeCell Identification 0	673

Table 9-6. GPIO Register Map (continued)

Offset	Name	Type	Reset	Description	See page
0xFF4	GPIOCellID1	RO	0x0000.00F0	GPIO PrimeCell Identification 1	674
0xFF8	GPIOCellID2	RO	0x0000.0005	GPIO PrimeCell Identification 2	675
0xFFC	GPIOCellID3	RO	0x0000.00B1	GPIO PrimeCell Identification 3	676

9.5 Register Descriptions

The remainder of this section lists and describes the GPIO registers, in numerical order by address offset.

Register 1: GPIO Data (GPIODATA), offset 0x000

The **GPIODATA** register is the data register. In software control mode, values written in the **GPIODATA** register are transferred onto the GPIO port pins if the respective pins have been configured as outputs through the **GPIO Direction (GPIODIR)** register (see page 636).

In order to write to **GPIODATA**, the corresponding bits in the mask, resulting from the address bus bits [9:2], must be set. Otherwise, the bit values remain unchanged by the write.

Similarly, the values read from this register are determined for each bit by the mask bit derived from the address used to access the data register, bits [9:2]. Bits that are set in the address mask cause the corresponding bits in **GPIODATA** to be read, and bits that are clear in the address mask cause the corresponding bits in **GPIODATA** to be read as 0, regardless of their value.

A read from **GPIODATA** returns the last bit value written if the respective pins are configured as outputs, or it returns the value on the corresponding input pin when these are configured as inputs. All bits are cleared by a reset.

GPIO Data (GPIODATA)

GPIO Port A (APB) base: 0x4000.4000
 GPIO Port A (AHB) base: 0x4005.8000
 GPIO Port B (APB) base: 0x4000.5000
 GPIO Port B (AHB) base: 0x4005.9000
 GPIO Port C (APB) base: 0x4000.6000
 GPIO Port C (AHB) base: 0x4005.A000
 GPIO Port D (APB) base: 0x4000.7000
 GPIO Port D (AHB) base: 0x4005.B000
 GPIO Port E (APB) base: 0x4002.4000
 GPIO Port E (AHB) base: 0x4005.C000
 GPIO Port F (APB) base: 0x4002.5000
 GPIO Port F (AHB) base: 0x4005.D000
 GPIO Port G (APB) base: 0x4002.6000
 GPIO Port G (AHB) base: 0x4005.E000
 Offset 0x000
 Type R/W, reset 0x0000.0000

	31	30	29	28	27	26	25	24	23	22	21	20	19	18	17	16
	reserved															
Type	RO	RO	RO	RO	RO	RO	RO	RO	RO	RO	RO	RO	RO	RO	RO	RO
Reset	0	0	0	0	0	0	0	0	0	0	0	0	0	0	0	0
	15	14	13	12	11	10	9	8	7	6	5	4	3	2	1	0
	reserved								DATA							
Type	RO	RO	RO	RO	RO	RO	RO	RO	R/W	R/W	R/W	R/W	R/W	R/W	R/W	R/W
Reset	0	0	0	0	0	0	0	0	0	0	0	0	0	0	0	0

Bit/Field	Name	Type	Reset	Description
31:8	reserved	RO	0x0000.00	Software should not rely on the value of a reserved bit. To provide compatibility with future products, the value of a reserved bit should be preserved across a read-modify-write operation.
7:0	DATA	R/W	0x00	GPIO Data This register is virtually mapped to 256 locations in the address space. To facilitate the reading and writing of data to these registers by independent drivers, the data read from and written to the registers are masked by the eight address lines [9:2]. Reads from this register return its current state. Writes to this register only affect bits that are not masked by ADDR[9:2] and are configured as outputs. See "Data Register Operation" on page 628 for examples of reads and writes.

Register 2: GPIO Direction (GPIODIR), offset 0x400

The **GPIODIR** register is the data direction register. Setting a bit in the **GPIODIR** register configures the corresponding pin to be an output, while clearing a bit configures the corresponding pin to be an input. All bits are cleared by a reset, meaning all GPIO pins are inputs by default.

GPIO Direction (GPIODIR)

GPIO Port A (APB) base: 0x4000.4000
 GPIO Port A (AHB) base: 0x4005.8000
 GPIO Port B (APB) base: 0x4000.5000
 GPIO Port B (AHB) base: 0x4005.9000
 GPIO Port C (APB) base: 0x4000.6000
 GPIO Port C (AHB) base: 0x4005.A000
 GPIO Port D (APB) base: 0x4000.7000
 GPIO Port D (AHB) base: 0x4005.B000
 GPIO Port E (APB) base: 0x4002.4000
 GPIO Port E (AHB) base: 0x4005.C000
 GPIO Port F (APB) base: 0x4002.5000
 GPIO Port F (AHB) base: 0x4005.D000
 GPIO Port G (APB) base: 0x4002.6000
 GPIO Port G (AHB) base: 0x4005.E000
 Offset 0x400
 Type R/W, reset 0x0000.0000

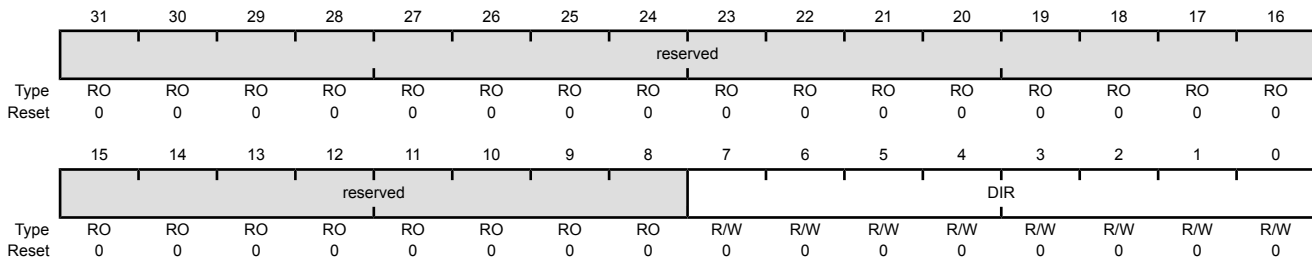

Bit/Field	Name	Type	Reset	Description
31:8	reserved	RO	0x0000.00	Software should not rely on the value of a reserved bit. To provide compatibility with future products, the value of a reserved bit should be preserved across a read-modify-write operation.
7:0	DIR	R/W	0x00	GPIO Data Direction
				Value Description
				0 Corresponding pin is an input.
				1 Corresponding pins is an output.

Register 3: GPIO Interrupt Sense (GPIOIS), offset 0x404

The **GPIOIS** register is the interrupt sense register. Setting a bit in the **GPIOIS** register configures the corresponding pin to detect levels, while clearing a bit configures the corresponding pin to detect edges. All bits are cleared by a reset.

GPIO Interrupt Sense (GPIOIS)

GPIO Port A (APB) base: 0x4000.4000
 GPIO Port A (AHB) base: 0x4005.8000
 GPIO Port B (APB) base: 0x4000.5000
 GPIO Port B (AHB) base: 0x4005.9000
 GPIO Port C (APB) base: 0x4000.6000
 GPIO Port C (AHB) base: 0x4005.A000
 GPIO Port D (APB) base: 0x4000.7000
 GPIO Port D (AHB) base: 0x4005.B000
 GPIO Port E (APB) base: 0x4002.4000
 GPIO Port E (AHB) base: 0x4005.C000
 GPIO Port F (APB) base: 0x4002.5000
 GPIO Port F (AHB) base: 0x4005.D000
 GPIO Port G (APB) base: 0x4002.6000
 GPIO Port G (AHB) base: 0x4005.E000

Offset 0x404

Type R/W, reset 0x0000.0000

	31	30	29	28	27	26	25	24	23	22	21	20	19	18	17	16
	reserved															
Type	RO	RO	RO	RO	RO	RO	RO	RO	RO	RO	RO	RO	RO	RO	RO	RO
Reset	0	0	0	0	0	0	0	0	0	0	0	0	0	0	0	0
	15	14	13	12	11	10	9	8	7	6	5	4	3	2	1	0
	reserved								IS							
Type	RO	RO	RO	RO	RO	RO	RO	RO	R/W	R/W	R/W	R/W	R/W	R/W	R/W	R/W
Reset	0	0	0	0	0	0	0	0	0	0	0	0	0	0	0	0

Bit/Field	Name	Type	Reset	Description
31:8	reserved	RO	0x0000.00	Software should not rely on the value of a reserved bit. To provide compatibility with future products, the value of a reserved bit should be preserved across a read-modify-write operation.

7:0	IS	R/W	0x00	GPIO Interrupt Sense
-----	----	-----	------	----------------------

Value Description

0	The edge on the corresponding pin is detected (edge-sensitive).
1	The level on the corresponding pin is detected (level-sensitive).

Register 4: GPIO Interrupt Both Edges (GPIOIBE), offset 0x408

The **GPIOIBE** register allows both edges to cause interrupts. When the corresponding bit in the **GPIO Interrupt Sense (GPIOIS)** register (see page 637) is set to detect edges, setting a bit in the **GPIOIBE** register configures the corresponding pin to detect both rising and falling edges, regardless of the corresponding bit in the **GPIO Interrupt Event (GPIOIEV)** register (see page 639). Clearing a bit configures the pin to be controlled by the **GPIOIEV** register. All bits are cleared by a reset.

GPIO Interrupt Both Edges (GPIOIBE)

GPIO Port A (APB) base: 0x4000.4000
 GPIO Port A (AHB) base: 0x4005.8000
 GPIO Port B (APB) base: 0x4000.5000
 GPIO Port B (AHB) base: 0x4005.9000
 GPIO Port C (APB) base: 0x4000.6000
 GPIO Port C (AHB) base: 0x4005.A000
 GPIO Port D (APB) base: 0x4000.7000
 GPIO Port D (AHB) base: 0x4005.B000
 GPIO Port E (APB) base: 0x4002.4000
 GPIO Port E (AHB) base: 0x4005.C000
 GPIO Port F (APB) base: 0x4002.5000
 GPIO Port F (AHB) base: 0x4005.D000
 GPIO Port G (APB) base: 0x4002.6000
 GPIO Port G (AHB) base: 0x4005.E000
 Offset 0x408
 Type R/W, reset 0x0000.0000

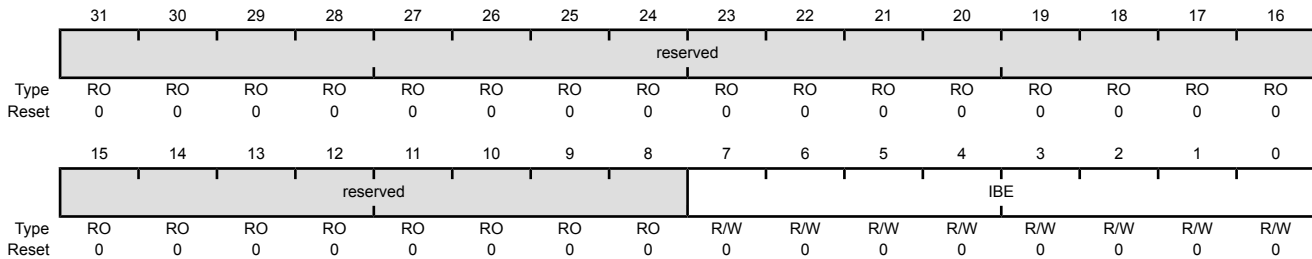

Bit/Field	Name	Type	Reset	Description
31:8	reserved	RO	0x0000.00	Software should not rely on the value of a reserved bit. To provide compatibility with future products, the value of a reserved bit should be preserved across a read-modify-write operation.
7:0	IBE	R/W	0x00	GPIO Interrupt Both Edges

Value	Description
0	Interrupt generation is controlled by the GPIO Interrupt Event (GPIOIEV) register (see page 639).
1	Both edges on the corresponding pin trigger an interrupt.

Register 5: GPIO Interrupt Event (GPIOIEV), offset 0x40C

The **GPIOIEV** register is the interrupt event register. Setting a bit in the **GPIOIEV** register configures the corresponding pin to detect rising edges or high levels, depending on the corresponding bit value in the **GPIO Interrupt Sense (GPIOIS)** register (see page 637). Clearing a bit configures the pin to detect falling edges or low levels, depending on the corresponding bit value in the **GPIOIS** register. All bits are cleared by a reset.

GPIO Interrupt Event (GPIOIEV)

GPIO Port A (APB) base: 0x4000.4000
 GPIO Port A (AHB) base: 0x4005.8000
 GPIO Port B (APB) base: 0x4000.5000
 GPIO Port B (AHB) base: 0x4005.9000
 GPIO Port C (APB) base: 0x4000.6000
 GPIO Port C (AHB) base: 0x4005.A000
 GPIO Port D (APB) base: 0x4000.7000
 GPIO Port D (AHB) base: 0x4005.B000
 GPIO Port E (APB) base: 0x4002.4000
 GPIO Port E (AHB) base: 0x4005.C000
 GPIO Port F (APB) base: 0x4002.5000
 GPIO Port F (AHB) base: 0x4005.D000
 GPIO Port G (APB) base: 0x4002.6000
 GPIO Port G (AHB) base: 0x4005.E000
 Offset 0x40C
 Type R/W, reset 0x0000.0000

	31	30	29	28	27	26	25	24	23	22	21	20	19	18	17	16
	reserved															
Type	RO	RO	RO	RO	RO	RO	RO	RO	RO	RO	RO	RO	RO	RO	RO	RO
Reset	0	0	0	0	0	0	0	0	0	0	0	0	0	0	0	0
	15	14	13	12	11	10	9	8	7	6	5	4	3	2	1	0
	reserved								IEV							
Type	RO	RO	RO	RO	RO	RO	RO	RO	R/W	R/W	R/W	R/W	R/W	R/W	R/W	R/W
Reset	0	0	0	0	0	0	0	0	0	0	0	0	0	0	0	0

Bit/Field	Name	Type	Reset	Description
31:8	reserved	RO	0x0000.00	Software should not rely on the value of a reserved bit. To provide compatibility with future products, the value of a reserved bit should be preserved across a read-modify-write operation.
7:0	IEV	R/W	0x00	GPIO Interrupt Event

Value Description

0	A falling edge or a Low level on the corresponding pin triggers an interrupt.
1	A rising edge or a High level on the corresponding pin triggers an interrupt.

Register 6: GPIO Interrupt Mask (GPIOIM), offset 0x410

The **GPIOIM** register is the interrupt mask register. Setting a bit in the **GPIOIM** register allows interrupts that are generated by the corresponding pin to be sent to the interrupt controller on the combined interrupt signal. Clearing a bit prevents an interrupt on the corresponding pin from being sent to the interrupt controller. All bits are cleared by a reset.

GPIO Interrupt Mask (GPIOIM)

GPIO Port A (APB) base: 0x4000.4000
 GPIO Port A (AHB) base: 0x4005.8000
 GPIO Port B (APB) base: 0x4000.5000
 GPIO Port B (AHB) base: 0x4005.9000
 GPIO Port C (APB) base: 0x4000.6000
 GPIO Port C (AHB) base: 0x4005.A000
 GPIO Port D (APB) base: 0x4000.7000
 GPIO Port D (AHB) base: 0x4005.B000
 GPIO Port E (APB) base: 0x4002.4000
 GPIO Port E (AHB) base: 0x4005.C000
 GPIO Port F (APB) base: 0x4002.5000
 GPIO Port F (AHB) base: 0x4005.D000
 GPIO Port G (APB) base: 0x4002.6000
 GPIO Port G (AHB) base: 0x4005.E000
 Offset 0x410
 Type R/W, reset 0x0000.0000

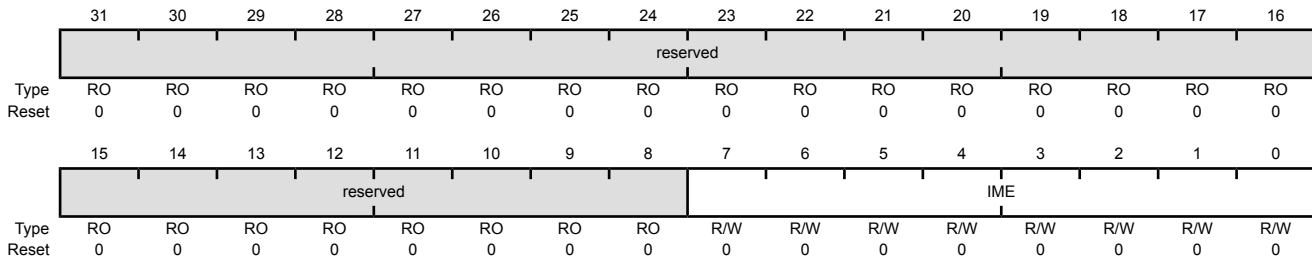

Bit/Field	Name	Type	Reset	Description
31:8	reserved	RO	0	Software should not rely on the value of a reserved bit. To provide compatibility with future products, the value of a reserved bit should be preserved across a read-modify-write operation.
7:0	IME	R/W	0x00	GPIO Interrupt Mask Enable

Value	Description
0	The interrupt from the corresponding pin is masked.
1	The interrupt from the corresponding pin is sent to the interrupt controller.

Register 7: GPIO Raw Interrupt Status (GPIORIS), offset 0x414

The **GPIORIS** register is the raw interrupt status register. A bit in this register is set when an interrupt condition occurs on the corresponding GPIO pin. If the corresponding bit in the **GPIO Interrupt Mask (GPIOIM)** register (see page 640) is set, the interrupt is sent to the interrupt controller. Bits read as zero indicate that corresponding input pins have not initiated an interrupt. A bit in this register can be cleared by writing a 1 to the corresponding bit in the **GPIO Interrupt Clear (GPIOICR)** register.

GPIO Raw Interrupt Status (GPIORIS)

GPIO Port A (APB) base: 0x4000.4000
 GPIO Port A (AHB) base: 0x4005.8000
 GPIO Port B (APB) base: 0x4000.5000
 GPIO Port B (AHB) base: 0x4005.9000
 GPIO Port C (APB) base: 0x4000.6000
 GPIO Port C (AHB) base: 0x4005.A000
 GPIO Port D (APB) base: 0x4000.7000
 GPIO Port D (AHB) base: 0x4005.B000
 GPIO Port E (APB) base: 0x4002.4000
 GPIO Port E (AHB) base: 0x4005.C000
 GPIO Port F (APB) base: 0x4002.5000
 GPIO Port F (AHB) base: 0x4005.D000
 GPIO Port G (APB) base: 0x4002.6000
 GPIO Port G (AHB) base: 0x4005.E000

Offset 0x414

Type RO, reset 0x0000.0000

	31	30	29	28	27	26	25	24	23	22	21	20	19	18	17	16
	reserved															
Type	RO	RO	RO	RO	RO	RO	RO	RO	RO	RO	RO	RO	RO	RO	RO	RO
Reset	0	0	0	0	0	0	0	0	0	0	0	0	0	0	0	0
	15	14	13	12	11	10	9	8	7	6	5	4	3	2	1	0
	reserved								RIS							
Type	RO	RO	RO	RO	RO	RO	RO	RO	RO	RO	RO	RO	RO	RO	RO	RO
Reset	0	0	0	0	0	0	0	0	0	0	0	0	0	0	0	0

Bit/Field	Name	Type	Reset	Description
31:8	reserved	RO	0	Software should not rely on the value of a reserved bit. To provide compatibility with future products, the value of a reserved bit should be preserved across a read-modify-write operation.
7:0	RIS	RO	0x00	GPIO Interrupt Raw Status

Value Description

0	An interrupt condition has not occurred on the corresponding pin.
1	An interrupt condition has occurred on the corresponding pin.

A bit is cleared by writing a 1 to the corresponding bit in the **GPIOICR** register.

Register 8: GPIO Masked Interrupt Status (GPIOMIS), offset 0x418

The **GPIOMIS** register is the masked interrupt status register. If a bit is set in this register, the corresponding interrupt has triggered an interrupt to the interrupt controller. If a bit is clear, either no interrupt has been generated, or the interrupt is masked.

Note that if the Port B **GPIOADCCTL** register is cleared, PB4 can still be used as an external trigger for the ADC. This is a legacy mode which allows code written for previous Stellaris devices to operate on this microcontroller.

GPIOMIS is the state of the interrupt after masking.

GPIO Masked Interrupt Status (GPIOMIS)

GPIO Port A (APB) base: 0x4000.4000
 GPIO Port A (AHB) base: 0x4005.8000
 GPIO Port B (APB) base: 0x4000.5000
 GPIO Port B (AHB) base: 0x4005.9000
 GPIO Port C (APB) base: 0x4000.6000
 GPIO Port C (AHB) base: 0x4005.A000
 GPIO Port D (APB) base: 0x4000.7000
 GPIO Port D (AHB) base: 0x4005.B000
 GPIO Port E (APB) base: 0x4002.4000
 GPIO Port E (AHB) base: 0x4005.C000
 GPIO Port F (APB) base: 0x4002.5000
 GPIO Port F (AHB) base: 0x4005.D000
 GPIO Port G (APB) base: 0x4002.6000
 GPIO Port G (AHB) base: 0x4005.E000
 Offset 0x418
 Type RO, reset 0x0000.0000

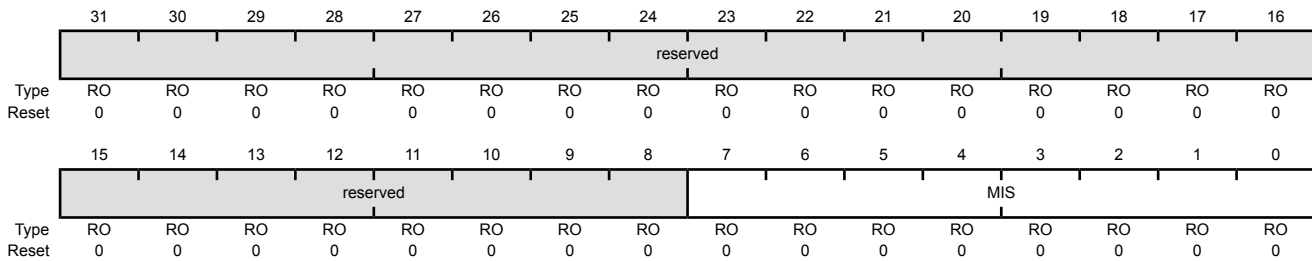

Bit/Field	Name	Type	Reset	Description
31:8	reserved	RO	0	Software should not rely on the value of a reserved bit. To provide compatibility with future products, the value of a reserved bit should be preserved across a read-modify-write operation.
7:0	MIS	RO	0x00	GPIO Masked Interrupt Status

Value	Description
0	An interrupt condition on the corresponding pin is masked or has not occurred.
1	An interrupt condition on the corresponding pin has triggered an interrupt to the interrupt controller.

A bit is cleared by writing a 1 to the corresponding bit in the **GPIOICR** register.

Register 9: GPIO Interrupt Clear (GPIOICR), offset 0x41C

The **GPIOICR** register is the interrupt clear register. Writing a 1 to a bit in this register clears the corresponding interrupt bit in the **GPIOIRIS** and **GPIOMIS** registers. Writing a 0 has no effect.

GPIO Interrupt Clear (GPIOICR)

GPIO Port A (APB) base: 0x4000.4000
 GPIO Port A (AHB) base: 0x4005.8000
 GPIO Port B (APB) base: 0x4000.5000
 GPIO Port B (AHB) base: 0x4005.9000
 GPIO Port C (APB) base: 0x4000.6000
 GPIO Port C (AHB) base: 0x4005.A000
 GPIO Port D (APB) base: 0x4000.7000
 GPIO Port D (AHB) base: 0x4005.B000
 GPIO Port E (APB) base: 0x4002.4000
 GPIO Port E (AHB) base: 0x4005.C000
 GPIO Port F (APB) base: 0x4002.5000
 GPIO Port F (AHB) base: 0x4005.D000
 GPIO Port G (APB) base: 0x4002.6000
 GPIO Port G (AHB) base: 0x4005.E000
 Offset 0x41C
 Type W1C, reset 0x0000.0000

	31	30	29	28	27	26	25	24	23	22	21	20	19	18	17	16
	reserved															
Type	RO	RO	RO	RO	RO	RO	RO	RO	RO	RO	RO	RO	RO	RO	RO	RO
Reset	0	0	0	0	0	0	0	0	0	0	0	0	0	0	0	0
	15	14	13	12	11	10	9	8	7	6	5	4	3	2	1	0
	reserved								IC							
Type	RO	RO	RO	RO	RO	RO	RO	RO	W1C	W1C	W1C	W1C	W1C	W1C	W1C	W1C
Reset	0	0	0	0	0	0	0	0	0	0	0	0	0	0	0	0

Bit/Field	Name	Type	Reset	Description
31:8	reserved	RO	0	Software should not rely on the value of a reserved bit. To provide compatibility with future products, the value of a reserved bit should be preserved across a read-modify-write operation.

7:0	IC	W1C	0x00	GPIO Interrupt Clear
-----	----	-----	------	----------------------

Value Description

0	The corresponding interrupt is unaffected.
1	The corresponding interrupt is cleared.

Register 10: GPIO Alternate Function Select (GPIOAFSEL), offset 0x420

The **GPIOAFSEL** register is the mode control select register. If a bit is clear, the pin is used as a GPIO and is controlled by the GPIO registers. Setting a bit in this register configures the corresponding GPIO line to be controlled by an associated peripheral. Several possible peripheral functions are multiplexed on each GPIO. The **GPIO Port Control (GPIOPCTL)** register is used to select one of the possible functions. Table 22-5 on page 1314 details which functions are muxed on each GPIO pin. The reset value for this register is 0x0000.0000 for GPIO ports that are not listed in the table below.

Important: All GPIO pins are configured as GPIOs and tri-stated by default (**GPIOAFSEL=0**, **GPIOIDEN=0**, **GPIOPDR=0**, **GPIOPUR=0**, and **GPIOPCTL=0**), with the exception of the pins shown in the table below. A Power-On-Reset (\overline{POR}) or asserting \overline{RST} puts the pins back to their default state.

Table 9-7. GPIO Pins With Non-Zero Reset Values

GPIO Pins	Default State	GPIOAFSEL	GPIOIDEN	GPIOPDR	GPIOPUR	GPIOPCTL
PA[1:0]	UART0	0	0	0	0	0x1
PA[5:2]	SSI0	0	0	0	0	0x2
PB[3:2]	I ² C0	0	0	0	0	0x3
PC[3:0]	JTAG/SWD	1	1	0	1	0x1

The GPIO commit control registers provide a layer of protection against accidental programming of critical hardware signals including the GPIO pins that can function as JTAG/SWD signals and the NMI signal. The commit control process must be followed for these pins, even if they are programmed as alternate functions other than JTAG/SWD or NMI, see “Commit Control” on page 630.

Caution – It is possible to create a software sequence that prevents the debugger from connecting to the Stellaris microcontroller. If the program code loaded into flash immediately changes the JTAG pins to their GPIO functionality, the debugger may not have enough time to connect and halt the controller before the JTAG pin functionality switches. As a result, the debugger may be locked out of the part. This issue can be avoided with a software routine that restores JTAG functionality based on an external or software trigger.

The GPIO commit control registers provide a layer of protection against accidental programming of critical hardware peripherals. Protection is provided for the GPIO pins that can be used as the four JTAG/SWD pins ($PC[3:0]$) and the NMI pin ($PD7$ and $PF0$). Writes to protected bits of the **GPIO Alternate Function Select (GPIOAFSEL)** register (see page 644), **GPIO Pull Up Select (GPIOPUR)** register (see page 650), **GPIO Pull-Down Select (GPIOPDR)** register (see page 652), and **GPIO Digital Enable (GPIOIDEN)** register (see page 655) are not committed to storage unless the **GPIO Lock (GPIOLOCK)** register (see page 657) has been unlocked and the appropriate bits of the **GPIO Commit (GPIOCR)** register (see page 658) have been set.

When using the I²C module, in addition to setting the **GPIOAFSEL** register bits for the I²C clock and data pins, the pins should be set to open drain using the **GPIO Open Drain Select (GPIOODR)** register (see examples in “Initialization and Configuration” on page 630).

GPIO Alternate Function Select (GPIOAFSEL)

GPIO Port A (APB) base: 0x4000.4000
 GPIO Port A (AHB) base: 0x4005.8000
 GPIO Port B (APB) base: 0x4000.5000
 GPIO Port B (AHB) base: 0x4005.9000
 GPIO Port C (APB) base: 0x4000.6000
 GPIO Port C (AHB) base: 0x4005.A000
 GPIO Port D (APB) base: 0x4000.7000
 GPIO Port D (AHB) base: 0x4005.B000
 GPIO Port E (APB) base: 0x4002.4000
 GPIO Port E (AHB) base: 0x4005.C000
 GPIO Port F (APB) base: 0x4002.5000
 GPIO Port F (AHB) base: 0x4005.D000
 GPIO Port G (APB) base: 0x4002.6000
 GPIO Port G (AHB) base: 0x4005.E000
 Offset 0x420

Type R/W, reset -

	31	30	29	28	27	26	25	24	23	22	21	20	19	18	17	16
	reserved															
Type	RO	RO	RO	RO	RO	RO	RO	RO	RO	RO	RO	RO	RO	RO	RO	RO
Reset	0	0	0	0	0	0	0	0	0	0	0	0	0	0	0	0
	15	14	13	12	11	10	9	8	7	6	5	4	3	2	1	0
	reserved								AFSEL							
Type	RO	RO	RO	RO	RO	RO	RO	RO	R/W	R/W	R/W	R/W	R/W	R/W	R/W	R/W
Reset	0	0	0	0	0	0	0	0	-	-	-	-	-	-	-	-

Bit/Field	Name	Type	Reset	Description
31:8	reserved	RO	0x0000.00	Software should not rely on the value of a reserved bit. To provide compatibility with future products, the value of a reserved bit should be preserved across a read-modify-write operation.
7:0	AFSEL	R/W	-	GPIO Alternate Function Select

Value Description

0 The associated pin functions as a GPIO and is controlled by the GPIO registers.

1 The associated pin functions as a peripheral signal and is controlled by the alternate hardware function.

The reset value for this register is 0x0000.0000 for GPIO ports that are not listed in Table 9-1 on page 624.

Register 11: GPIO 2-mA Drive Select (GPIODR2R), offset 0x500

The **GPIODR2R** register is the 2-mA drive control register. Each GPIO signal in the port can be individually configured without affecting the other pads. When setting the **DRV2** bit for a GPIO signal, the corresponding **DRV4** bit in the **GPIODR4R** register and **DRV8** bit in the **GPIODR8R** register are automatically cleared by hardware. By default, all GPIO pins have 2-mA drive.

GPIO 2-mA Drive Select (GPIODR2R)

GPIO Port A (APB) base: 0x4000.4000
 GPIO Port A (AHB) base: 0x4005.8000
 GPIO Port B (APB) base: 0x4000.5000
 GPIO Port B (AHB) base: 0x4005.9000
 GPIO Port C (APB) base: 0x4000.6000
 GPIO Port C (AHB) base: 0x4005.A000
 GPIO Port D (APB) base: 0x4000.7000
 GPIO Port D (AHB) base: 0x4005.B000
 GPIO Port E (APB) base: 0x4002.4000
 GPIO Port E (AHB) base: 0x4005.C000
 GPIO Port F (APB) base: 0x4002.5000
 GPIO Port F (AHB) base: 0x4005.D000
 GPIO Port G (APB) base: 0x4002.6000
 GPIO Port G (AHB) base: 0x4005.E000
 Offset 0x500
 Type R/W, reset 0x0000.00FF

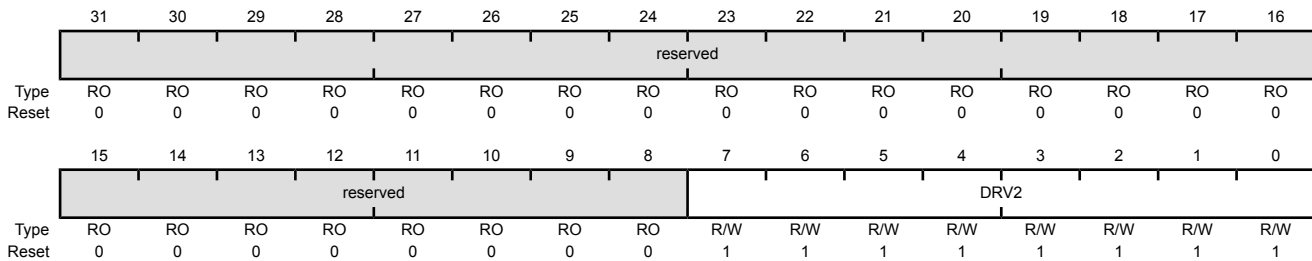

Bit/Field	Name	Type	Reset	Description
31:8	reserved	RO	0x0000.00	Software should not rely on the value of a reserved bit. To provide compatibility with future products, the value of a reserved bit should be preserved across a read-modify-write operation.
7:0	DRV2	R/W	0xFF	Output Pad 2-mA Drive Enable

Value	Description
1	The corresponding GPIO pin has 2-mA drive.
0	The drive for the corresponding GPIO pin is controlled by the GPIODR4R or GPIODR8R register.

Setting a bit in either the **GPIODR4** register or the **GPIODR8** register clears the corresponding 2-mA enable bit. The change is effective on the second clock cycle after the write if accessing GPIO via the APB memory aperture. If using AHB access, the change is effective on the next clock cycle.

Register 12: GPIO 4-mA Drive Select (GPIODR4R), offset 0x504

The **GPIODR4R** register is the 4-mA drive control register. Each GPIO signal in the port can be individually configured without affecting the other pads. When setting the **DRV4** bit for a GPIO signal, the corresponding **DRV2** bit in the **GPIODR2R** register and **DRV8** bit in the **GPIODR8R** register are automatically cleared by hardware.

GPIO 4-mA Drive Select (GPIODR4R)

GPIO Port A (APB) base: 0x4000.4000
 GPIO Port A (AHB) base: 0x4005.8000
 GPIO Port B (APB) base: 0x4000.5000
 GPIO Port B (AHB) base: 0x4005.9000
 GPIO Port C (APB) base: 0x4000.6000
 GPIO Port C (AHB) base: 0x4005.A000
 GPIO Port D (APB) base: 0x4000.7000
 GPIO Port D (AHB) base: 0x4005.B000
 GPIO Port E (APB) base: 0x4002.4000
 GPIO Port E (AHB) base: 0x4005.C000
 GPIO Port F (APB) base: 0x4002.5000
 GPIO Port F (AHB) base: 0x4005.D000
 GPIO Port G (APB) base: 0x4002.6000
 GPIO Port G (AHB) base: 0x4005.E000
 Offset 0x504
 Type R/W, reset 0x0000.0000

	31	30	29	28	27	26	25	24	23	22	21	20	19	18	17	16
	reserved															
Type	RO	RO	RO	RO	RO	RO	RO	RO	RO	RO	RO	RO	RO	RO	RO	RO
Reset	0	0	0	0	0	0	0	0	0	0	0	0	0	0	0	0
	15	14	13	12	11	10	9	8	7	6	5	4	3	2	1	0
	reserved								DRV4							
Type	RO	RO	RO	RO	RO	RO	RO	RO	R/W	R/W	R/W	R/W	R/W	R/W	R/W	R/W
Reset	0	0	0	0	0	0	0	0	0	0	0	0	0	0	0	0

Bit/Field	Name	Type	Reset	Description
31:8	reserved	RO	0x0000.00	Software should not rely on the value of a reserved bit. To provide compatibility with future products, the value of a reserved bit should be preserved across a read-modify-write operation.
7:0	DRV4	R/W	0x00	Output Pad 4-mA Drive Enable

Value Description

1	The corresponding GPIO pin has 4-mA drive.
0	The drive for the corresponding GPIO pin is controlled by the GPIODR2R or GPIODR8R register.

Setting a bit in either the **GPIODR2** register or the **GPIODR8** register clears the corresponding 4-mA enable bit. The change is effective on the second clock cycle after the write if accessing GPIO via the APB memory aperture. If using AHB access, the change is effective on the next clock cycle.

Register 13: GPIO 8-mA Drive Select (GPIODR8R), offset 0x508

The **GPIODR8R** register is the 8-mA drive control register. Each GPIO signal in the port can be individually configured without affecting the other pads. When setting the **DRV8** bit for a GPIO signal, the corresponding **DRV2** bit in the **GPIODR2R** register and **DRV4** bit in the **GPIODR4R** register are automatically cleared by hardware. The 8-mA setting is also used for high-current operation.

Note: There is no configuration difference between 8-mA and high-current operation. The additional current capacity results from a shift in the V_{OH}/V_{OL} levels. See “Recommended Operating Conditions” on page 1323 for further information.

GPIO 8-mA Drive Select (GPIODR8R)

GPIO Port A (APB) base: 0x4000.4000
 GPIO Port A (AHB) base: 0x4005.8000
 GPIO Port B (APB) base: 0x4000.5000
 GPIO Port B (AHB) base: 0x4005.9000
 GPIO Port C (APB) base: 0x4000.6000
 GPIO Port C (AHB) base: 0x4005.A000
 GPIO Port D (APB) base: 0x4000.7000
 GPIO Port D (AHB) base: 0x4005.B000
 GPIO Port E (APB) base: 0x4002.4000
 GPIO Port E (AHB) base: 0x4005.C000
 GPIO Port F (APB) base: 0x4002.5000
 GPIO Port F (AHB) base: 0x4005.D000
 GPIO Port G (APB) base: 0x4002.6000
 GPIO Port G (AHB) base: 0x4005.E000
 Offset 0x508
 Type R/W, reset 0x0000.0000

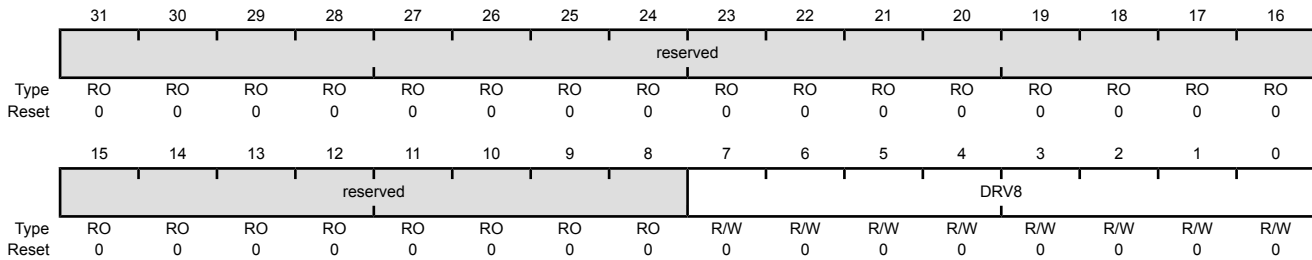

Bit/Field	Name	Type	Reset	Description
31:8	reserved	RO	0x0000.00	Software should not rely on the value of a reserved bit. To provide compatibility with future products, the value of a reserved bit should be preserved across a read-modify-write operation.
7:0	DRV8	R/W	0x00	Output Pad 8-mA Drive Enable

Value Description

- 1 The corresponding GPIO pin has 8-mA drive.
- 0 The drive for the corresponding GPIO pin is controlled by the **GPIODR2R** or **GPIODR4R** register.

Setting a bit in either the **GPIODR2** register or the **GPIODR4** register clears the corresponding 8-mA enable bit. The change is effective on the second clock cycle after the write if accessing GPIO via the APB memory aperture. If using AHB access, the change is effective on the next clock cycle.

Register 14: GPIO Open Drain Select (GPIOODR), offset 0x50C

The **GPIOODR** register is the open drain control register. Setting a bit in this register enables the open-drain configuration of the corresponding GPIO pad. When open-drain mode is enabled, the corresponding bit should also be set in the **GPIO Digital Enable (GPIODEN)** register (see page 655). Corresponding bits in the drive strength and slew rate control registers (**GPIODR2R**, **GPIODR4R**, **GPIODR8R**, and **GPIOSLR**) can be set to achieve the desired rise and fall times. The GPIO acts as an input if the corresponding bit in the **GPIODIR** register is cleared. If open drain is selected while the GPIO is configured as an input, the GPIO will remain an input and the open-drain selection has no effect until the GPIO is changed to an output.

When using the I²C module, in addition to configuring the pin to open drain, the **GPIO Alternate Function Select (GPIOAFSEL)** register bits for the I²C data pins should be set (see examples in “Initialization and Configuration” on page 630).

GPIO Open Drain Select (GPIOODR)

GPIO Port A (APB) base: 0x4000.4000
 GPIO Port A (AHB) base: 0x4005.8000
 GPIO Port B (APB) base: 0x4000.5000
 GPIO Port B (AHB) base: 0x4005.9000
 GPIO Port C (APB) base: 0x4000.6000
 GPIO Port C (AHB) base: 0x4005.A000
 GPIO Port D (APB) base: 0x4000.7000
 GPIO Port D (AHB) base: 0x4005.B000
 GPIO Port E (APB) base: 0x4002.4000
 GPIO Port E (AHB) base: 0x4005.C000
 GPIO Port F (APB) base: 0x4002.5000
 GPIO Port F (AHB) base: 0x4005.D000
 GPIO Port G (APB) base: 0x4002.6000
 GPIO Port G (AHB) base: 0x4005.E000
 Offset 0x50C
 Type R/W, reset 0x0000.0000

	31	30	29	28	27	26	25	24	23	22	21	20	19	18	17	16
	reserved															
Type	RO	RO	RO	RO	RO	RO	RO	RO	RO	RO	RO	RO	RO	RO	RO	RO
Reset	0	0	0	0	0	0	0	0	0	0	0	0	0	0	0	0
	15	14	13	12	11	10	9	8	7	6	5	4	3	2	1	0
	reserved								ODE							
Type	RO	RO	RO	RO	RO	RO	RO	RO	R/W	R/W	R/W	R/W	R/W	R/W	R/W	R/W
Reset	0	0	0	0	0	0	0	0	0	0	0	0	0	0	0	0

Bit/Field	Name	Type	Reset	Description
31:8	reserved	RO	0x0000.00	Software should not rely on the value of a reserved bit. To provide compatibility with future products, the value of a reserved bit should be preserved across a read-modify-write operation.
7:0	ODE	R/W	0x00	Output Pad Open Drain Enable
				Value Description
				1 The corresponding pin is configured as open drain.
				0 The corresponding pin is not configured as open drain.

Register 15: GPIO Pull-Up Select (GPIOPUR), offset 0x510

The **GPIOPUR** register is the pull-up control register. When a bit is set, a weak pull-up resistor on the corresponding GPIO signal is enabled. Setting a bit in **GPIOPUR** automatically clears the corresponding bit in the **GPIO Pull-Down Select (GPIOPDR)** register (see page 652). Write access to this register is protected with the **GPIOCR** register. Bits in **GPIOCR** that are cleared prevent writes to the equivalent bit in this register.

Important: All GPIO pins are configured as GPIOs and tri-stated by default (**GPIOAFSEL**=0, **GPIODEN**=0, **GPIOPDR**=0, **GPIOPUR**=0, and **GPIOPCTL**=0), with the exception of the pins shown in the table below. A Power-On-Reset (\overline{POR}) or asserting \overline{RST} puts the pins back to their default state.

Table 9-8. GPIO Pins With Non-Zero Reset Values

GPIO Pins	Default State	GPIOAFSEL	GPIODEN	GPIOPDR	GPIOPUR	GPIOPCTL
PA[1:0]	UART0	0	0	0	0	0x1
PA[5:2]	SSI0	0	0	0	0	0x2
PB[3:2]	I ² C0	0	0	0	0	0x3
PC[3:0]	JTAG/SWD	1	1	0	1	0x1

The GPIO commit control registers provide a layer of protection against accidental programming of critical hardware signals including the GPIO pins that can function as JTAG/SWD signals and the NMI signal. The commit control process must be followed for these pins, even if they are programmed as alternate functions other than JTAG/SWD or NMI, see “Commit Control” on page 630.

Note: The GPIO commit control registers provide a layer of protection against accidental programming of critical hardware peripherals. Protection is provided for the GPIO pins that can be used as the four JTAG/SWD pins ($PC[3:0]$) and the NMI pin ($PD7$ and $PF0$). Writes to protected bits of the **GPIO Alternate Function Select (GPIOAFSEL)** register (see page 644), **GPIO Pull Up Select (GPIOPUR)** register (see page 650), **GPIO Pull-Down Select (GPIOPDR)** register (see page 652), and **GPIO Digital Enable (GPIODEN)** register (see page 655) are not committed to storage unless the **GPIO Lock (GPIOLOCK)** register (see page 657) has been unlocked and the appropriate bits of the **GPIO Commit (GPIOCR)** register (see page 658) have been set.

GPIO Pull-Up Select (GPIOPUR)

GPIO Port A (APB) base: 0x4000.4000
 GPIO Port A (AHB) base: 0x4005.8000
 GPIO Port B (APB) base: 0x4000.5000
 GPIO Port B (AHB) base: 0x4005.9000
 GPIO Port C (APB) base: 0x4000.6000
 GPIO Port C (AHB) base: 0x4005.A000
 GPIO Port D (APB) base: 0x4000.7000
 GPIO Port D (AHB) base: 0x4005.B000
 GPIO Port E (APB) base: 0x4002.4000
 GPIO Port E (AHB) base: 0x4005.C000
 GPIO Port F (APB) base: 0x4002.5000
 GPIO Port F (AHB) base: 0x4005.D000
 GPIO Port G (APB) base: 0x4002.6000
 GPIO Port G (AHB) base: 0x4005.E000
 Offset 0x510

Type R/W, reset -

	31	30	29	28	27	26	25	24	23	22	21	20	19	18	17	16
	reserved															
Type	RO	RO	RO	RO	RO	RO	RO	RO	RO	RO	RO	RO	RO	RO	RO	RO
Reset	0	0	0	0	0	0	0	0	0	0	0	0	0	0	0	0
	15	14	13	12	11	10	9	8	7	6	5	4	3	2	1	0
	reserved								PUE							
Type	RO	RO	RO	RO	RO	RO	RO	RO	R/W	R/W	R/W	R/W	R/W	R/W	R/W	R/W
Reset	0	0	0	0	0	0	0	0	-	-	-	-	-	-	-	-

Bit/Field	Name	Type	Reset	Description
31:8	reserved	RO	0x0000.00	Software should not rely on the value of a reserved bit. To provide compatibility with future products, the value of a reserved bit should be preserved across a read-modify-write operation.
7:0	PUE	R/W	-	Pad Weak Pull-Up Enable

Value Description
 1 The corresponding pin has a weak pull-up resistor.
 0 The corresponding pin is not affected.

Setting a bit in the **GPIOPDR** register clears the corresponding bit in the **GPIOPUR** register. The change is effective on the second clock cycle after the write if accessing GPIO via the APB memory aperture. If using AHB access, the change is effective on the next clock cycle.
 The reset value for this register is 0x0000.0000 for GPIO ports that are not listed in Table 9-1 on page 624.

Register 16: GPIO Pull-Down Select (GPIOPDR), offset 0x514

The **GPIOPDR** register is the pull-down control register. When a bit is set, a weak pull-down resistor on the corresponding GPIO signal is enabled. Setting a bit in **GPIOPDR** automatically clears the corresponding bit in the **GPIO Pull-Up Select (GPIOPUR)** register (see page 650).

Important: All GPIO pins are configured as GPIOs and tri-stated by default (**GPIOAFSEL**=0, **GPIODEN**=0, **GPIOPDR**=0, **GPIOPUR**=0, and **GPIOPCTL**=0), with the exception of the pins shown in the table below. A Power-On-Reset (**POR**) or asserting **RST** puts the pins back to their default state.

Table 9-9. GPIO Pins With Non-Zero Reset Values

GPIO Pins	Default State	GPIOAFSEL	GPIODEN	GPIOPDR	GPIOPUR	GPIOPCTL
PA[1:0]	UART0	0	0	0	0	0x1
PA[5:2]	SSI0	0	0	0	0	0x2
PB[3:2]	I ² C0	0	0	0	0	0x3
PC[3:0]	JTAG/SWD	1	1	0	1	0x1

The GPIO commit control registers provide a layer of protection against accidental programming of critical hardware signals including the GPIO pins that can function as JTAG/SWD signals and the NMI signal. The commit control process must be followed for these pins, even if they are programmed as alternate functions other than JTAG/SWD or NMI, see “Commit Control” on page 630.

Note: The GPIO commit control registers provide a layer of protection against accidental programming of critical hardware peripherals. Protection is provided for the GPIO pins that can be used as the four JTAG/SWD pins (**PC[3:0]**) and the NMI pin (**PD7** and **PF0**). Writes to protected bits of the **GPIO Alternate Function Select (GPIOAFSEL)** register (see page 644), **GPIO Pull Up Select (GPIOPUR)** register (see page 650), **GPIO Pull-Down Select (GPIOPDR)** register (see page 652), and **GPIO Digital Enable (GPIODEN)** register (see page 655) are not committed to storage unless the **GPIO Lock (GPIOLOCK)** register (see page 657) has been unlocked and the appropriate bits of the **GPIO Commit (GPIOCR)** register (see page 658) have been set.

GPIO Pull-Down Select (GPIOPDR)

GPIO Port A (APB) base: 0x4000.4000
 GPIO Port A (AHB) base: 0x4005.8000
 GPIO Port B (APB) base: 0x4000.5000
 GPIO Port B (AHB) base: 0x4005.9000
 GPIO Port C (APB) base: 0x4000.6000
 GPIO Port C (AHB) base: 0x4005.A000
 GPIO Port D (APB) base: 0x4000.7000
 GPIO Port D (AHB) base: 0x4005.B000
 GPIO Port E (APB) base: 0x4002.4000
 GPIO Port E (AHB) base: 0x4005.C000
 GPIO Port F (APB) base: 0x4002.5000
 GPIO Port F (AHB) base: 0x4005.D000
 GPIO Port G (APB) base: 0x4002.6000
 GPIO Port G (AHB) base: 0x4005.E000
 Offset 0x514
 Type R/W, reset 0x0000.0000

	31	30	29	28	27	26	25	24	23	22	21	20	19	18	17	16
	reserved															
Type	RO	RO	RO	RO	RO	RO	RO	RO	RO	RO	RO	RO	RO	RO	RO	RO
Reset	0	0	0	0	0	0	0	0	0	0	0	0	0	0	0	0
	15	14	13	12	11	10	9	8	7	6	5	4	3	2	1	0
	reserved								PDE							
Type	RO	RO	RO	RO	RO	RO	RO	RO	R/W	R/W	R/W	R/W	R/W	R/W	R/W	R/W
Reset	0	0	0	0	0	0	0	0	0	0	0	0	0	0	0	0

Bit/Field	Name	Type	Reset	Description
31:8	reserved	RO	0x0000.00	Software should not rely on the value of a reserved bit. To provide compatibility with future products, the value of a reserved bit should be preserved across a read-modify-write operation.
7:0	PDE	R/W	0x00	Pad Weak Pull-Down Enable

Value Description

1	The corresponding pin has a weak pull-down resistor.
0	The corresponding pin is not affected.

Setting a bit in the **GPIOPUR** register clears the corresponding bit in the **GPIOPDR** register. The change is effective on the second clock cycle after the write if accessing GPIO via the APB memory aperture. If using AHB access, the change is effective on the next clock cycle.

Register 17: GPIO Slew Rate Control Select (GPIOSLR), offset 0x518

The **GPIOSLR** register is the slew rate control register. Slew rate control is only available when using the 8-mA drive strength option via the **GPIO 8-mA Drive Select (GPIODR8R)** register (see page 648).

GPIO Slew Rate Control Select (GPIOSLR)

GPIO Port A (APB) base: 0x4000.4000
 GPIO Port A (AHB) base: 0x4005.8000
 GPIO Port B (APB) base: 0x4000.5000
 GPIO Port B (AHB) base: 0x4005.9000
 GPIO Port C (APB) base: 0x4000.6000
 GPIO Port C (AHB) base: 0x4005.A000
 GPIO Port D (APB) base: 0x4000.7000
 GPIO Port D (AHB) base: 0x4005.B000
 GPIO Port E (APB) base: 0x4002.4000
 GPIO Port E (AHB) base: 0x4005.C000
 GPIO Port F (APB) base: 0x4002.5000
 GPIO Port F (AHB) base: 0x4005.D000
 GPIO Port G (APB) base: 0x4002.6000
 GPIO Port G (AHB) base: 0x4005.E000
 Offset 0x518
 Type R/W, reset 0x0000.0000

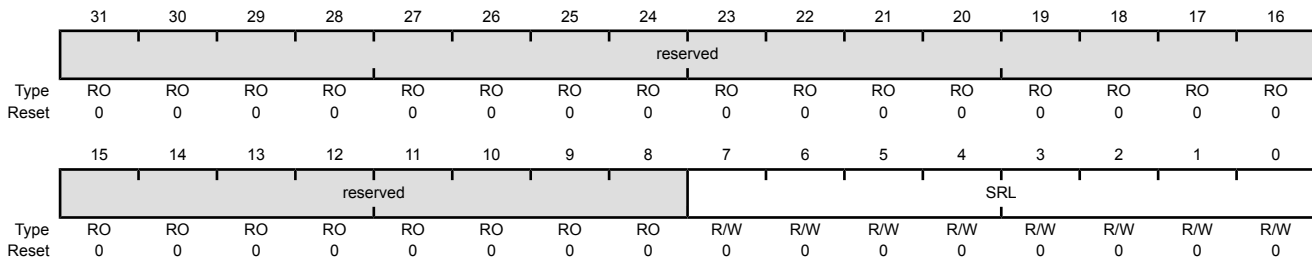

Bit/Field	Name	Type	Reset	Description
31:8	reserved	RO	0x0000.00	Software should not rely on the value of a reserved bit. To provide compatibility with future products, the value of a reserved bit should be preserved across a read-modify-write operation.
7:0	SRL	R/W	0x00	Slew Rate Limit Enable (8-mA drive only)

Value	Description
1	Slew rate control is enabled for the corresponding pin.
0	Slew rate control is disabled for the corresponding pin.

Register 18: GPIO Digital Enable (GPIODEN), offset 0x51C

Note: Pins configured as digital inputs are Schmitt-triggered.

The **GPIODEN** register is the digital enable register. By default, all GPIO signals except those listed below are configured out of reset to be undriven (tristate). Their digital function is disabled; they do not drive a logic value on the pin and they do not allow the pin voltage into the GPIO receiver. To use the pin as a digital input or output (either GPIO or alternate function), the corresponding **GPIODEN** bit must be set.

Important: All GPIO pins are configured as GPIOs and tri-stated by default (**GPIOAFSEL**=0, **GPIODEN**=0, **GPIOPDR**=0, **GPIOPUR**=0, and **GPIOPCTL**=0), with the exception of the pins shown in the table below. A Power-On-Reset (\overline{POR}) or asserting \overline{RST} puts the pins back to their default state.

Table 9-10. GPIO Pins With Non-Zero Reset Values

GPIO Pins	Default State	GPIOAFSEL	GPIODEN	GPIOPDR	GPIOPUR	GPIOPCTL
PA[1:0]	UART0	0	0	0	0	0x1
PA[5:2]	SSI0	0	0	0	0	0x2
PB[3:2]	I ² C0	0	0	0	0	0x3
PC[3:0]	JTAG/SWD	1	1	0	1	0x1

The GPIO commit control registers provide a layer of protection against accidental programming of critical hardware signals including the GPIO pins that can function as JTAG/SWD signals and the NMI signal. The commit control process must be followed for these pins, even if they are programmed as alternate functions other than JTAG/SWD or NMI, see “Commit Control” on page 630.

Note: The GPIO commit control registers provide a layer of protection against accidental programming of critical hardware peripherals. Protection is provided for the GPIO pins that can be used as the four JTAG/SWD pins ($PC[3:0]$) and the NMI pin ($PD7$ and $PF0$). Writes to protected bits of the **GPIO Alternate Function Select (GPIOAFSEL)** register (see page 644), **GPIO Pull Up Select (GPIOPUR)** register (see page 650), **GPIO Pull-Down Select (GPIOPDR)** register (see page 652), and **GPIO Digital Enable (GPIODEN)** register (see page 655) are not committed to storage unless the **GPIO Lock (GPIOLOCK)** register (see page 657) has been unlocked and the appropriate bits of the **GPIO Commit (GPIOCR)** register (see page 658) have been set.

GPIO Digital Enable (GPIODEN)

GPIO Port A (APB) base: 0x4000.4000
 GPIO Port A (AHB) base: 0x4005.8000
 GPIO Port B (APB) base: 0x4000.5000
 GPIO Port B (AHB) base: 0x4005.9000
 GPIO Port C (APB) base: 0x4000.6000
 GPIO Port C (AHB) base: 0x4005.A000
 GPIO Port D (APB) base: 0x4000.7000
 GPIO Port D (AHB) base: 0x4005.B000
 GPIO Port E (APB) base: 0x4002.4000
 GPIO Port E (AHB) base: 0x4005.C000
 GPIO Port F (APB) base: 0x4002.5000
 GPIO Port F (AHB) base: 0x4005.D000
 GPIO Port G (APB) base: 0x4002.6000
 GPIO Port G (AHB) base: 0x4005.E000
 Offset 0x51C

Type R/W, reset -

	31	30	29	28	27	26	25	24	23	22	21	20	19	18	17	16
	reserved															
Type	RO	RO	RO	RO	RO	RO	RO	RO	RO	RO	RO	RO	RO	RO	RO	RO
Reset	0	0	0	0	0	0	0	0	0	0	0	0	0	0	0	0
	15	14	13	12	11	10	9	8	7	6	5	4	3	2	1	0
	reserved								DEN							
Type	RO	RO	RO	RO	RO	RO	RO	RO	R/W	R/W	R/W	R/W	R/W	R/W	R/W	R/W
Reset	0	0	0	0	0	0	0	0	-	-	-	-	-	-	-	-

Bit/Field	Name	Type	Reset	Description
31:8	reserved	RO	0x0000.00	Software should not rely on the value of a reserved bit. To provide compatibility with future products, the value of a reserved bit should be preserved across a read-modify-write operation.
7:0	DEN	R/W	-	Digital Enable

Value Description

- 0 The digital functions for the corresponding pin are disabled.
- 1 The digital functions for the corresponding pin are enabled.

The reset value for this register is 0x0000.0000 for GPIO ports that are not listed in Table 9-1 on page 624.

Register 19: GPIO Lock (GPIOLOCK), offset 0x520

The **GPIOLOCK** register enables write access to the **GPIOCR** register (see page 658). Writing 0x4C4F.434B to the **GPIOLOCK** register unlocks the **GPIOCR** register. Writing any other value to the **GPIOLOCK** register re-enables the locked state. Reading the **GPIOLOCK** register returns the lock status rather than the 32-bit value that was previously written. Therefore, when write accesses are disabled, or locked, reading the **GPIOLOCK** register returns 0x0000.0001. When write accesses are enabled, or unlocked, reading the **GPIOLOCK** register returns 0x0000.0000.

GPIO Lock (GPIOLOCK)

GPIO Port A (APB) base: 0x4000.4000
 GPIO Port A (AHB) base: 0x4005.8000
 GPIO Port B (APB) base: 0x4000.5000
 GPIO Port B (AHB) base: 0x4005.9000
 GPIO Port C (APB) base: 0x4000.6000
 GPIO Port C (AHB) base: 0x4005.A000
 GPIO Port D (APB) base: 0x4000.7000
 GPIO Port D (AHB) base: 0x4005.B000
 GPIO Port E (APB) base: 0x4002.4000
 GPIO Port E (AHB) base: 0x4005.C000
 GPIO Port F (APB) base: 0x4002.5000
 GPIO Port F (AHB) base: 0x4005.D000
 GPIO Port G (APB) base: 0x4002.6000
 GPIO Port G (AHB) base: 0x4005.E000
 Offset 0x520

Type R/W, reset 0x0000.0001

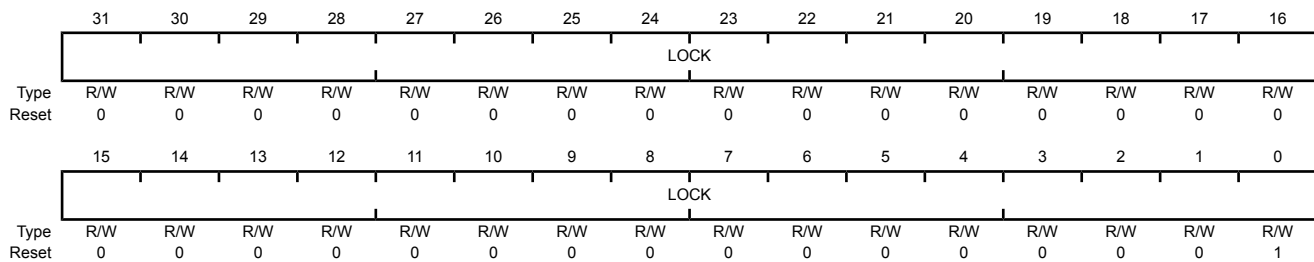

Bit/Field	Name	Type	Reset	Description
31:0	LOCK	R/W	0x0000.0001	GPIO Lock

A write of the value 0x4C4F.434B unlocks the **GPIO Commit (GPIOCR)** register for write access. A write of any other value or a write to the **GPIOCR** register reapplies the lock, preventing any register updates.

A read of this register returns the following values:

Value Description

0x1 The **GPIOCR** register is locked and may not be modified.

0x0 The **GPIOCR** register is unlocked and may be modified.

Register 20: GPIO Commit (GPIOCR), offset 0x524

The **GPIOCR** register is the commit register. The value of the **GPIOCR** register determines which bits of the **GPIOAFSEL**, **GPIOPUR**, **GPIOPDR**, and **GPIODEN** registers are committed when a write to these registers is performed. If a bit in the **GPIOCR** register is cleared, the data being written to the corresponding bit in the **GPIOAFSEL**, **GPIOPUR**, **GPIOPDR**, or **GPIODEN** registers cannot be committed and retains its previous value. If a bit in the **GPIOCR** register is set, the data being written to the corresponding bit of the **GPIOAFSEL**, **GPIOPUR**, **GPIOPDR**, or **GPIODEN** registers is committed to the register and reflects the new value.

The contents of the **GPIOCR** register can only be modified if the status in the **GPIOLOCK** register is unlocked. Writes to the **GPIOCR** register are ignored if the status in the **GPIOLOCK** register is locked.

Important: This register is designed to prevent accidental programming of the registers that control connectivity to the NMI and JTAG/SWD debug hardware. By initializing the bits of the **GPIOCR** register to 0 for **PD7**, **PF0**, and **PC[3:0]**, the NMI and JTAG/SWD debug port can only be converted to GPIOs through a deliberate set of writes to the **GPIOLOCK**, **GPIOCR**, and the corresponding registers.

Because this protection is currently only implemented on the NMI and JTAG/SWD pins on **PD7**, **PF0**, and **PC[3:0]**, all of the other bits in the **GPIOCR** registers cannot be written with 0x0. These bits are hardwired to 0x1, ensuring that it is always possible to commit new values to the **GPIOAFSEL**, **GPIOPUR**, **GPIOPDR**, or **GPIODEN** register bits of these other pins.

GPIO Commit (GPIOCR)

GPIO Port A (APB) base: 0x4000.4000
 GPIO Port A (AHB) base: 0x4005.8000
 GPIO Port B (APB) base: 0x4000.5000
 GPIO Port B (AHB) base: 0x4005.9000
 GPIO Port C (APB) base: 0x4000.6000
 GPIO Port C (AHB) base: 0x4005.A000
 GPIO Port D (APB) base: 0x4000.7000
 GPIO Port D (AHB) base: 0x4005.B000
 GPIO Port E (APB) base: 0x4002.4000
 GPIO Port E (AHB) base: 0x4005.C000
 GPIO Port F (APB) base: 0x4002.5000
 GPIO Port F (AHB) base: 0x4005.D000
 GPIO Port G (APB) base: 0x4002.6000
 GPIO Port G (AHB) base: 0x4005.E000
 Offset 0x524
 Type -, reset -

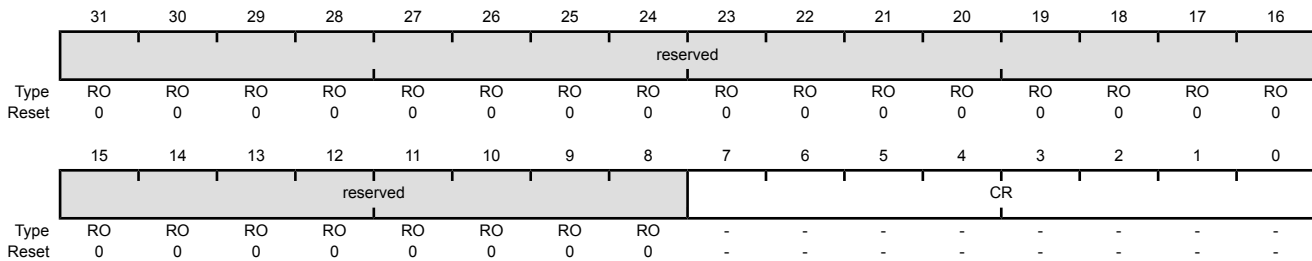

Bit/Field	Name	Type	Reset	Description
31:8	reserved	RO	0x0000.00	Software should not rely on the value of a reserved bit. To provide compatibility with future products, the value of a reserved bit should be preserved across a read-modify-write operation.

Bit/Field	Name	Type	Reset	Description
7:0	CR	-	-	GPIO Commit
				Value Description
				1 The corresponding GPIODEN , GPIOPUR , GPIOPDR , or GPIODEN bits can be written.
				0 The corresponding GPIODEN , GPIOPUR , GPIOPDR , or GPIODEN bits cannot be written.
				Note: The default register type for the GPIOCR register is RO for all GPIO pins with the exception of the NMI pin and the four JTAG/SWD pins (PD7 , PF0 , and PC[3:0]). These six pins are the only GPIOs that are protected by the GPIOCR register. Because of this, the register type for GPIO Port D7, GPIO Port F0, and GPIO Port C[3:0] is R/W.
				The default reset value for the GPIOCR register is 0x0000.00FF for all GPIO pins, with the exception of the NMI pin and the four JTAG/SWD pins (PD7 , PF0 , and PC[3:0]). To ensure that the JTAG port is not accidentally programmed as GPIO pins, the PC[3:0] pins default to non-committable. Similarly, to ensure that the NMI pin is not accidentally programmed as a GPIO pin, the PD7 and PF0 pins default to non-committable. Because of this, the default reset value of GPIOCR for GPIO Port C is 0x0000.00F0, for GPIO Port D is 0x0000.007F, and for GPIO Port F is 0x0000.00FE.

Register 21: GPIO Analog Mode Select (GPIOAMSEL), offset 0x528

Important: This register is only valid for ports and pins that can be used as ADC AINx inputs.

If any pin is to be used as an ADC input, the appropriate bit in **GPIOAMSEL** must be set to disable the analog isolation circuit.

The **GPIOAMSEL** register controls isolation circuits to the analog side of a unified I/O pad. Because the GPIOs may be driven by a 5-V source and affect analog operation, analog circuitry requires isolation from the pins when they are not used in their analog function.

Each bit of this register controls the isolation circuitry for the corresponding GPIO signal. For information on which GPIO pins can be used for ADC functions, refer to Table 22-5 on page 1314.

GPIO Analog Mode Select (GPIOAMSEL)

GPIO Port A (APB) base: 0x4000.4000
 GPIO Port A (AHB) base: 0x4005.8000
 GPIO Port B (APB) base: 0x4000.5000
 GPIO Port B (AHB) base: 0x4005.9000
 GPIO Port C (APB) base: 0x4000.6000
 GPIO Port C (AHB) base: 0x4005.A000
 GPIO Port D (APB) base: 0x4000.7000
 GPIO Port D (AHB) base: 0x4005.B000
 GPIO Port E (APB) base: 0x4002.4000
 GPIO Port E (AHB) base: 0x4005.C000
 GPIO Port F (APB) base: 0x4002.5000
 GPIO Port F (AHB) base: 0x4005.D000
 GPIO Port G (APB) base: 0x4002.6000
 GPIO Port G (AHB) base: 0x4005.E000
 Offset 0x528
 Type R/W, reset 0x0000.0000

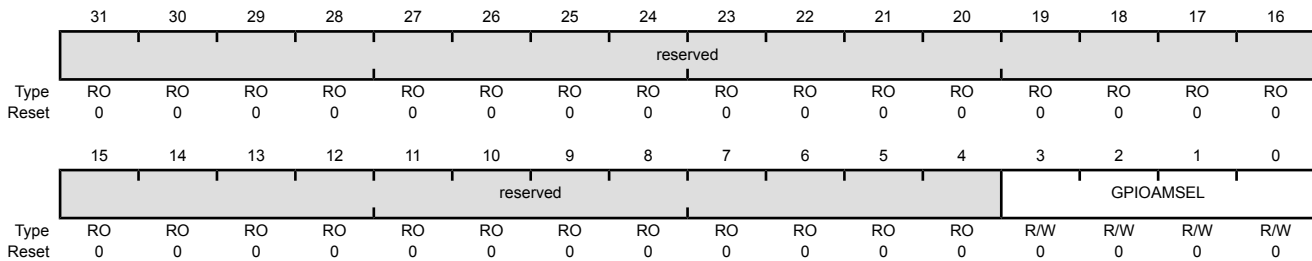

Bit/Field	Name	Type	Reset	Description
31:4	reserved	RO	0x0000.000	Software should not rely on the value of a reserved bit. To provide compatibility with future products, the value of a reserved bit should be preserved across a read-modify-write operation.
3:0	GPIOAMSEL	R/W	0x0	GPIO Analog Mode Select

Value	Description
1	The analog function of the pin is enabled, the isolation is disabled, and the pin is capable of analog functions.
0	The analog function of the pin is disabled, the isolation is enabled, and the pin is capable of digital functions as specified by the other GPIO configuration registers.

Note: This register and bits are only valid for GPIO signals that share analog function through a unified I/O pad.

The reset state of this register is 0 for all signals.

Register 22: GPIO Port Control (GPIOCTL), offset 0x52C

The **GPIOCTL** register is used in conjunction with the **GPIOAFSEL** register and selects the specific peripheral signal for each GPIO pin when using the alternate function mode. Most bits in the **GPIOAFSEL** register are cleared on reset, therefore most GPIO pins are configured as GPIOs by default. When a bit is set in the **GPIOAFSEL** register, the corresponding GPIO signal is controlled by an associated peripheral. The **GPIOCTL** register selects one out of a set of peripheral functions for each GPIO, providing additional flexibility in signal definition. For information on the defined encodings for the bit fields in this register, refer to Table 22-5 on page 1314. The reset value for this register is 0x0000.0000 for GPIO ports that are not listed in the table below.

Note: If the same signal is assigned to two different GPIO port pins, the signal is assigned to the port with the lowest letter and the assignment to the higher letter port is ignored.

Important: All GPIO pins are configured as GPIOs and tri-stated by default (**GPIOAFSEL**=0, **GPIODEN**=0, **GPIOPDR**=0, **GPIOPUR**=0, and **GPIOCTL**=0), with the exception of the pins shown in the table below. A Power-On-Reset (\overline{POR}) or asserting \overline{RST} puts the pins back to their default state.

Table 9-11. GPIO Pins With Non-Zero Reset Values

GPIO Pins	Default State	GPIOAFSEL	GPIODEN	GPIOPDR	GPIOPUR	GPIOCTL
PA[1:0]	UART0	0	0	0	0	0x1
PA[5:2]	SSI0	0	0	0	0	0x2
PB[3:2]	I ² C0	0	0	0	0	0x3
PC[3:0]	JTAG/SWD	1	1	0	1	0x1

The GPIO commit control registers provide a layer of protection against accidental programming of critical hardware signals including the GPIO pins that can function as JTAG/SWD signals and the NMI signal. The commit control process must be followed for these pins, even if they are programmed as alternate functions other than JTAG/SWD or NMI, see “Commit Control” on page 630.

GPIO Port Control (GPIOCTL)

GPIO Port A (APB) base: 0x4000.4000
 GPIO Port A (AHB) base: 0x4005.8000
 GPIO Port B (APB) base: 0x4000.5000
 GPIO Port B (AHB) base: 0x4005.9000
 GPIO Port C (APB) base: 0x4000.6000
 GPIO Port C (AHB) base: 0x4005.A000
 GPIO Port D (APB) base: 0x4000.7000
 GPIO Port D (AHB) base: 0x4005.B000
 GPIO Port E (APB) base: 0x4002.4000
 GPIO Port E (AHB) base: 0x4005.C000
 GPIO Port F (APB) base: 0x4002.5000
 GPIO Port F (AHB) base: 0x4005.D000
 GPIO Port G (APB) base: 0x4002.6000
 GPIO Port G (AHB) base: 0x4005.E000

Offset 0x52C
 Type R/W, reset -

	31	30	29	28	27	26	25	24	23	22	21	20	19	18	17	16
	PMC7				PMC6				PMC5				PMC4			
Type	R/W	R/W	R/W	R/W	R/W	R/W	R/W	R/W	R/W	R/W	R/W	R/W	R/W	R/W	R/W	R/W
Reset	-	-	-	-	-	-	-	-	-	-	-	-	-	-	-	-
	15	14	13	12	11	10	9	8	7	6	5	4	3	2	1	0
	PMC3				PMC2				PMC1				PMC0			
Type	R/W	R/W	R/W	R/W	R/W	R/W	R/W	R/W	R/W	R/W	R/W	R/W	R/W	R/W	R/W	R/W
Reset	-	-	-	-	-	-	-	-	-	-	-	-	-	-	-	-

Bit/Field	Name	Type	Reset	Description
31:28	PMC7	R/W	-	Port Mux Control 7 This field controls the configuration for GPIO pin 7.
27:24	PMC6	R/W	-	Port Mux Control 6 This field controls the configuration for GPIO pin 6.
23:20	PMC5	R/W	-	Port Mux Control 5 This field controls the configuration for GPIO pin 5.
19:16	PMC4	R/W	-	Port Mux Control 4 This field controls the configuration for GPIO pin 4.
15:12	PMC3	R/W	-	Port Mux Control 3 This field controls the configuration for GPIO pin 3.
11:8	PMC2	R/W	-	Port Mux Control 2 This field controls the configuration for GPIO pin 2.
7:4	PMC1	R/W	-	Port Mux Control 1 This field controls the configuration for GPIO pin 1.
3:0	PMC0	R/W	-	Port Mux Control 0 This field controls the configuration for GPIO pin 0.

Register 23: GPIO ADC Control (GPIOADCCTL), offset 0x530

This register is used to configure a GPIO pin as a source for the ADC trigger.

Note that if the Port B **GPIOADCCTL** register is cleared, PB4 can still be used as an external trigger for the ADC. This is a legacy mode which allows code written for previous Stellaris devices to operate on this microcontroller.

GPIO ADC Control (GPIOADCCTL)

GPIO Port A (APB) base: 0x4000.4000
 GPIO Port A (AHB) base: 0x4005.8000
 GPIO Port B (APB) base: 0x4000.5000
 GPIO Port B (AHB) base: 0x4005.9000
 GPIO Port C (APB) base: 0x4000.6000
 GPIO Port C (AHB) base: 0x4005.A000
 GPIO Port D (APB) base: 0x4000.7000
 GPIO Port D (AHB) base: 0x4005.B000
 GPIO Port E (APB) base: 0x4002.4000
 GPIO Port E (AHB) base: 0x4005.C000
 GPIO Port F (APB) base: 0x4002.5000
 GPIO Port F (AHB) base: 0x4005.D000
 GPIO Port G (APB) base: 0x4002.6000
 GPIO Port G (AHB) base: 0x4005.E000
 Offset 0x530
 Type R/W, reset 0x0000.0000

	31	30	29	28	27	26	25	24	23	22	21	20	19	18	17	16
	reserved															
Type	RO	RO	RO	RO	RO	RO	RO	RO	RO	RO	RO	RO	RO	RO	RO	RO
Reset	0	0	0	0	0	0	0	0	0	0	0	0	0	0	0	0
	15	14	13	12	11	10	9	8	7	6	5	4	3	2	1	0
	reserved								ADCEN							
Type	RO	RO	RO	RO	RO	RO	RO	RO	R/W	R/W	R/W	R/W	R/W	R/W	R/W	R/W
Reset	0	0	0	0	0	0	0	0	0	0	0	0	0	0	0	0

Bit/Field	Name	Type	Reset	Description
31:8	reserved	RO	0x0000.00	Software should not rely on the value of a reserved bit. To provide compatibility with future products, the value of a reserved bit should be preserved across a read-modify-write operation.
7:0	ADCEN	R/W	0x00	ADC Trigger Enable
	Value	Description		
	1	The corresponding pin is used to trigger the ADC.		
	0	The corresponding pin is not used to trigger the ADC.		

Register 24: GPIO DMA Control (GPIODMACTL), offset 0x534

This register is used to configure a GPIO pin as a source for the μ DMA trigger.

GPIO DMA Control (GPIODMACTL)

GPIO Port A (APB) base: 0x4000.4000
 GPIO Port A (AHB) base: 0x4005.8000
 GPIO Port B (APB) base: 0x4000.5000
 GPIO Port B (AHB) base: 0x4005.9000
 GPIO Port C (APB) base: 0x4000.6000
 GPIO Port C (AHB) base: 0x4005.A000
 GPIO Port D (APB) base: 0x4000.7000
 GPIO Port D (AHB) base: 0x4005.B000
 GPIO Port E (APB) base: 0x4002.4000
 GPIO Port E (AHB) base: 0x4005.C000
 GPIO Port F (APB) base: 0x4002.5000
 GPIO Port F (AHB) base: 0x4005.D000
 GPIO Port G (APB) base: 0x4002.6000
 GPIO Port G (AHB) base: 0x4005.E000
 Offset 0x534
 Type R/W, reset 0x0000.0000

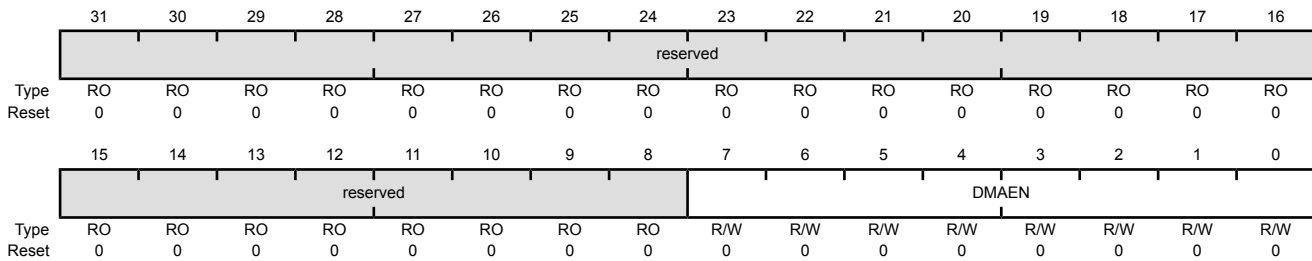

Bit/Field	Name	Type	Reset	Description
31:8	reserved	RO	0x0000.00	Software should not rely on the value of a reserved bit. To provide compatibility with future products, the value of a reserved bit should be preserved across a read-modify-write operation.
7:0	DMAEN	R/W	0x00	μ DMA Trigger Enable

Value	Description
1	The corresponding pin is used to trigger the μ DMA.
0	The corresponding pin is not used to trigger the μ DMA.

Register 25: GPIO Peripheral Identification 4 (GPIOPeriphID4), offset 0xFD0

The **GPIOPeriphID4**, **GPIOPeriphID5**, **GPIOPeriphID6**, and **GPIOPeriphID7** registers can conceptually be treated as one 32-bit register; each register contains eight bits of the 32-bit register, used by software to identify the peripheral.

GPIO Peripheral Identification 4 (GPIOPeriphID4)

GPIO Port A (APB) base: 0x4000.4000
 GPIO Port A (AHB) base: 0x4005.8000
 GPIO Port B (APB) base: 0x4000.5000
 GPIO Port B (AHB) base: 0x4005.9000
 GPIO Port C (APB) base: 0x4000.6000
 GPIO Port C (AHB) base: 0x4005.A000
 GPIO Port D (APB) base: 0x4000.7000
 GPIO Port D (AHB) base: 0x4005.B000
 GPIO Port E (APB) base: 0x4002.4000
 GPIO Port E (AHB) base: 0x4005.C000
 GPIO Port F (APB) base: 0x4002.5000
 GPIO Port F (AHB) base: 0x4005.D000
 GPIO Port G (APB) base: 0x4002.6000
 GPIO Port G (AHB) base: 0x4005.E000

Offset 0xFD0

Type RO, reset 0x0000.0000

	31	30	29	28	27	26	25	24	23	22	21	20	19	18	17	16
	reserved															
Type	RO	RO	RO	RO	RO	RO	RO	RO	RO	RO	RO	RO	RO	RO	RO	RO
Reset	0	0	0	0	0	0	0	0	0	0	0	0	0	0	0	0
	15	14	13	12	11	10	9	8	7	6	5	4	3	2	1	0
	reserved								PID4							
Type	RO	RO	RO	RO	RO	RO	RO	RO	RO	RO	RO	RO	RO	RO	RO	RO
Reset	0	0	0	0	0	0	0	0	0	0	0	0	0	0	0	0

Bit/Field	Name	Type	Reset	Description
31:8	reserved	RO	0x0000.00	Software should not rely on the value of a reserved bit. To provide compatibility with future products, the value of a reserved bit should be preserved across a read-modify-write operation.
7:0	PID4	RO	0x00	GPIO Peripheral ID Register [7:0]

Register 26: GPIO Peripheral Identification 5 (GPIOPeriphID5), offset 0xFD4

The **GPIOPeriphID4**, **GPIOPeriphID5**, **GPIOPeriphID6**, and **GPIOPeriphID7** registers can conceptually be treated as one 32-bit register; each register contains eight bits of the 32-bit register, used by software to identify the peripheral.

GPIO Peripheral Identification 5 (GPIOPeriphID5)

GPIO Port A (APB) base: 0x4000.4000
 GPIO Port A (AHB) base: 0x4005.8000
 GPIO Port B (APB) base: 0x4000.5000
 GPIO Port B (AHB) base: 0x4005.9000
 GPIO Port C (APB) base: 0x4000.6000
 GPIO Port C (AHB) base: 0x4005.A000
 GPIO Port D (APB) base: 0x4000.7000
 GPIO Port D (AHB) base: 0x4005.B000
 GPIO Port E (APB) base: 0x4002.4000
 GPIO Port E (AHB) base: 0x4005.C000
 GPIO Port F (APB) base: 0x4002.5000
 GPIO Port F (AHB) base: 0x4005.D000
 GPIO Port G (APB) base: 0x4002.6000
 GPIO Port G (AHB) base: 0x4005.E000
 Offset 0xFD4
 Type RO, reset 0x0000.0000

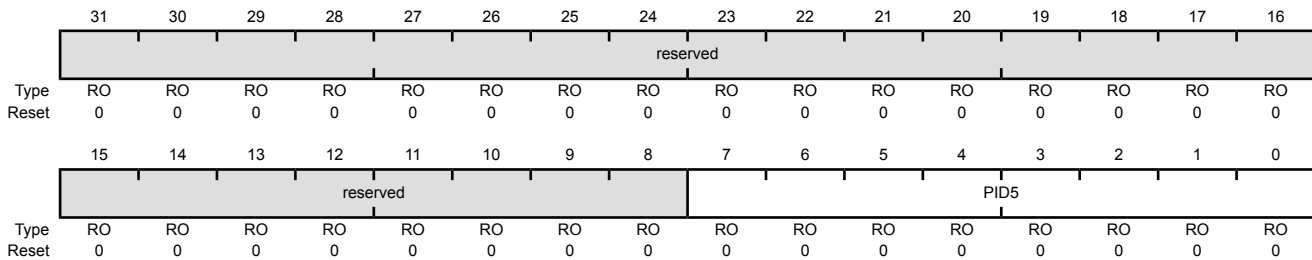

Bit/Field	Name	Type	Reset	Description
31:8	reserved	RO	0x0000.00	Software should not rely on the value of a reserved bit. To provide compatibility with future products, the value of a reserved bit should be preserved across a read-modify-write operation.
7:0	PID5	RO	0x00	GPIO Peripheral ID Register [15:8]

Register 27: GPIO Peripheral Identification 6 (GPIOPeriphID6), offset 0xFD8

The **GPIOPeriphID4**, **GPIOPeriphID5**, **GPIOPeriphID6**, and **GPIOPeriphID7** registers can conceptually be treated as one 32-bit register; each register contains eight bits of the 32-bit register, used by software to identify the peripheral.

GPIO Peripheral Identification 6 (GPIOPeriphID6)

GPIO Port A (APB) base: 0x4000.4000
 GPIO Port A (AHB) base: 0x4005.8000
 GPIO Port B (APB) base: 0x4000.5000
 GPIO Port B (AHB) base: 0x4005.9000
 GPIO Port C (APB) base: 0x4000.6000
 GPIO Port C (AHB) base: 0x4005.A000
 GPIO Port D (APB) base: 0x4000.7000
 GPIO Port D (AHB) base: 0x4005.B000
 GPIO Port E (APB) base: 0x4002.4000
 GPIO Port E (AHB) base: 0x4005.C000
 GPIO Port F (APB) base: 0x4002.5000
 GPIO Port F (AHB) base: 0x4005.D000
 GPIO Port G (APB) base: 0x4002.6000
 GPIO Port G (AHB) base: 0x4005.E000

Offset 0xFD8

Type RO, reset 0x0000.0000

	31	30	29	28	27	26	25	24	23	22	21	20	19	18	17	16
	reserved															
Type	RO	RO	RO	RO	RO	RO	RO	RO	RO	RO	RO	RO	RO	RO	RO	RO
Reset	0	0	0	0	0	0	0	0	0	0	0	0	0	0	0	0
	15	14	13	12	11	10	9	8	7	6	5	4	3	2	1	0
	reserved								PID6							
Type	RO	RO	RO	RO	RO	RO	RO	RO	RO	RO	RO	RO	RO	RO	RO	RO
Reset	0	0	0	0	0	0	0	0	0	0	0	0	0	0	0	0

Bit/Field	Name	Type	Reset	Description
31:8	reserved	RO	0x0000.00	Software should not rely on the value of a reserved bit. To provide compatibility with future products, the value of a reserved bit should be preserved across a read-modify-write operation.
7:0	PID6	RO	0x00	GPIO Peripheral ID Register [23:16]

Register 28: GPIO Peripheral Identification 7 (GPIOPeriphID7), offset 0xFDC

The **GPIOPeriphID4**, **GPIOPeriphID5**, **GPIOPeriphID6**, and **GPIOPeriphID7** registers can conceptually be treated as one 32-bit register; each register contains eight bits of the 32-bit register, used by software to identify the peripheral.

GPIO Peripheral Identification 7 (GPIOPeriphID7)

GPIO Port A (APB) base: 0x4000.4000
 GPIO Port A (AHB) base: 0x4005.8000
 GPIO Port B (APB) base: 0x4000.5000
 GPIO Port B (AHB) base: 0x4005.9000
 GPIO Port C (APB) base: 0x4000.6000
 GPIO Port C (AHB) base: 0x4005.A000
 GPIO Port D (APB) base: 0x4000.7000
 GPIO Port D (AHB) base: 0x4005.B000
 GPIO Port E (APB) base: 0x4002.4000
 GPIO Port E (AHB) base: 0x4005.C000
 GPIO Port F (APB) base: 0x4002.5000
 GPIO Port F (AHB) base: 0x4005.D000
 GPIO Port G (APB) base: 0x4002.6000
 GPIO Port G (AHB) base: 0x4005.E000
 Offset 0xFDC
 Type RO, reset 0x0000.0000

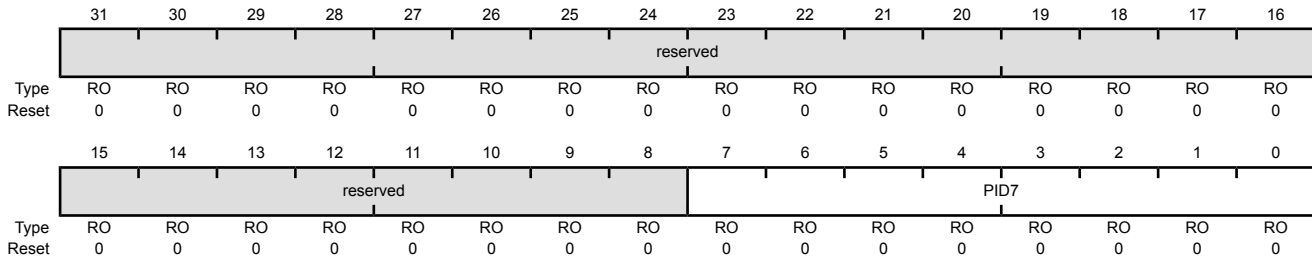

Bit/Field	Name	Type	Reset	Description
31:8	reserved	RO	0x0000.00	Software should not rely on the value of a reserved bit. To provide compatibility with future products, the value of a reserved bit should be preserved across a read-modify-write operation.
7:0	PID7	RO	0x00	GPIO Peripheral ID Register [31:24]

Register 29: GPIO Peripheral Identification 0 (GPIOPeriphID0), offset 0xFE0

The **GPIOPeriphID0**, **GPIOPeriphID1**, **GPIOPeriphID2**, and **GPIOPeriphID3** registers can conceptually be treated as one 32-bit register; each register contains eight bits of the 32-bit register, used by software to identify the peripheral.

GPIO Peripheral Identification 0 (GPIOPeriphID0)

GPIO Port A (APB) base: 0x4000.4000
 GPIO Port A (AHB) base: 0x4005.8000
 GPIO Port B (APB) base: 0x4000.5000
 GPIO Port B (AHB) base: 0x4005.9000
 GPIO Port C (APB) base: 0x4000.6000
 GPIO Port C (AHB) base: 0x4005.A000
 GPIO Port D (APB) base: 0x4000.7000
 GPIO Port D (AHB) base: 0x4005.B000
 GPIO Port E (APB) base: 0x4002.4000
 GPIO Port E (AHB) base: 0x4005.C000
 GPIO Port F (APB) base: 0x4002.5000
 GPIO Port F (AHB) base: 0x4005.D000
 GPIO Port G (APB) base: 0x4002.6000
 GPIO Port G (AHB) base: 0x4005.E000
 Offset 0xFE0
 Type RO, reset 0x0000.0061

	31	30	29	28	27	26	25	24	23	22	21	20	19	18	17	16
	reserved															
Type	RO	RO	RO	RO	RO	RO	RO	RO	RO	RO	RO	RO	RO	RO	RO	RO
Reset	0	0	0	0	0	0	0	0	0	0	0	0	0	0	0	0
	15	14	13	12	11	10	9	8	7	6	5	4	3	2	1	0
	reserved								PID0							
Type	RO	RO	RO	RO	RO	RO	RO	RO	RO	RO	RO	RO	RO	RO	RO	RO
Reset	0	0	0	0	0	0	0	0	0	1	1	0	0	0	0	1

Bit/Field	Name	Type	Reset	Description
31:8	reserved	RO	0x0000.00	Software should not rely on the value of a reserved bit. To provide compatibility with future products, the value of a reserved bit should be preserved across a read-modify-write operation.
7:0	PID0	RO	0x61	GPIO Peripheral ID Register [7:0] Can be used by software to identify the presence of this peripheral.

Register 30: GPIO Peripheral Identification 1 (GPIOPeriphID1), offset 0xFE4

The **GPIOPeriphID0**, **GPIOPeriphID1**, **GPIOPeriphID2**, and **GPIOPeriphID3** registers can conceptually be treated as one 32-bit register; each register contains eight bits of the 32-bit register, used by software to identify the peripheral.

GPIO Peripheral Identification 1 (GPIOPeriphID1)

GPIO Port A (APB) base: 0x4000.4000
 GPIO Port A (AHB) base: 0x4005.8000
 GPIO Port B (APB) base: 0x4000.5000
 GPIO Port B (AHB) base: 0x4005.9000
 GPIO Port C (APB) base: 0x4000.6000
 GPIO Port C (AHB) base: 0x4005.A000
 GPIO Port D (APB) base: 0x4000.7000
 GPIO Port D (AHB) base: 0x4005.B000
 GPIO Port E (APB) base: 0x4002.4000
 GPIO Port E (AHB) base: 0x4005.C000
 GPIO Port F (APB) base: 0x4002.5000
 GPIO Port F (AHB) base: 0x4005.D000
 GPIO Port G (APB) base: 0x4002.6000
 GPIO Port G (AHB) base: 0x4005.E000
 Offset 0xFE4
 Type RO, reset 0x0000.0000

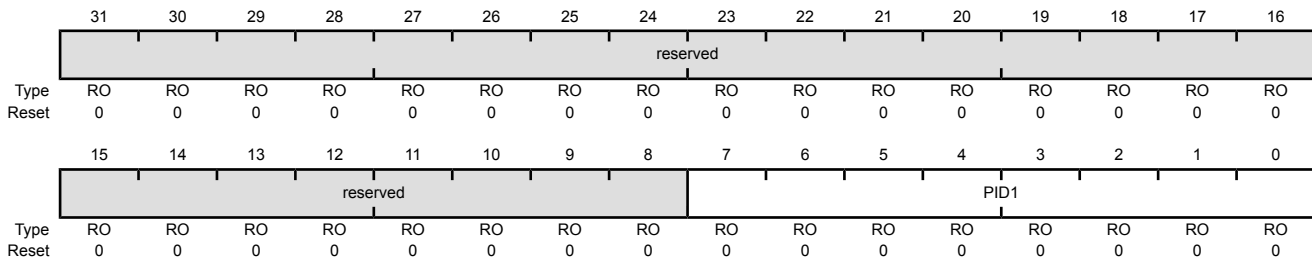

Bit/Field	Name	Type	Reset	Description
31:8	reserved	RO	0x0000.00	Software should not rely on the value of a reserved bit. To provide compatibility with future products, the value of a reserved bit should be preserved across a read-modify-write operation.
7:0	PID1	RO	0x00	GPIO Peripheral ID Register [15:8] Can be used by software to identify the presence of this peripheral.

Register 31: GPIO Peripheral Identification 2 (GPIOPeriphID2), offset 0xFE8

The **GPIOPeriphID0**, **GPIOPeriphID1**, **GPIOPeriphID2**, and **GPIOPeriphID3** registers can conceptually be treated as one 32-bit register; each register contains eight bits of the 32-bit register, used by software to identify the peripheral.

GPIO Peripheral Identification 2 (GPIOPeriphID2)

GPIO Port A (APB) base: 0x4000.4000
 GPIO Port A (AHB) base: 0x4005.8000
 GPIO Port B (APB) base: 0x4000.5000
 GPIO Port B (AHB) base: 0x4005.9000
 GPIO Port C (APB) base: 0x4000.6000
 GPIO Port C (AHB) base: 0x4005.A000
 GPIO Port D (APB) base: 0x4000.7000
 GPIO Port D (AHB) base: 0x4005.B000
 GPIO Port E (APB) base: 0x4002.4000
 GPIO Port E (AHB) base: 0x4005.C000
 GPIO Port F (APB) base: 0x4002.5000
 GPIO Port F (AHB) base: 0x4005.D000
 GPIO Port G (APB) base: 0x4002.6000
 GPIO Port G (AHB) base: 0x4005.E000

Offset 0xFE8

Type RO, reset 0x0000.0018

	31	30	29	28	27	26	25	24	23	22	21	20	19	18	17	16
	reserved															
Type	RO	RO	RO	RO	RO	RO	RO	RO	RO	RO	RO	RO	RO	RO	RO	RO
Reset	0	0	0	0	0	0	0	0	0	0	0	0	0	0	0	0
	15	14	13	12	11	10	9	8	7	6	5	4	3	2	1	0
	reserved								PID2							
Type	RO	RO	RO	RO	RO	RO	RO	RO	RO	RO	RO	RO	RO	RO	RO	RO
Reset	0	0	0	0	0	0	0	0	0	0	0	0	1	1	0	0

Bit/Field	Name	Type	Reset	Description
31:8	reserved	RO	0x0000.00	Software should not rely on the value of a reserved bit. To provide compatibility with future products, the value of a reserved bit should be preserved across a read-modify-write operation.
7:0	PID2	RO	0x18	GPIO Peripheral ID Register [23:16] Can be used by software to identify the presence of this peripheral.

Register 32: GPIO Peripheral Identification 3 (GPIOPeriphID3), offset 0xFEC

The **GPIOPeriphID0**, **GPIOPeriphID1**, **GPIOPeriphID2**, and **GPIOPeriphID3** registers can conceptually be treated as one 32-bit register; each register contains eight bits of the 32-bit register, used by software to identify the peripheral.

GPIO Peripheral Identification 3 (GPIOPeriphID3)

GPIO Port A (APB) base: 0x4000.4000
 GPIO Port A (AHB) base: 0x4005.8000
 GPIO Port B (APB) base: 0x4000.5000
 GPIO Port B (AHB) base: 0x4005.9000
 GPIO Port C (APB) base: 0x4000.6000
 GPIO Port C (AHB) base: 0x4005.A000
 GPIO Port D (APB) base: 0x4000.7000
 GPIO Port D (AHB) base: 0x4005.B000
 GPIO Port E (APB) base: 0x4002.4000
 GPIO Port E (AHB) base: 0x4005.C000
 GPIO Port F (APB) base: 0x4002.5000
 GPIO Port F (AHB) base: 0x4005.D000
 GPIO Port G (APB) base: 0x4002.6000
 GPIO Port G (AHB) base: 0x4005.E000
 Offset 0xFEC
 Type RO, reset 0x0000.0001

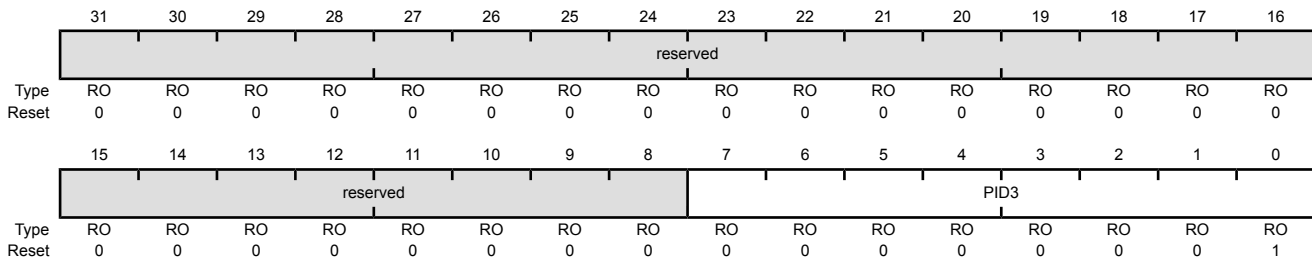

Bit/Field	Name	Type	Reset	Description
31:8	reserved	RO	0x0000.00	Software should not rely on the value of a reserved bit. To provide compatibility with future products, the value of a reserved bit should be preserved across a read-modify-write operation.
7:0	PID3	RO	0x01	GPIO Peripheral ID Register [31:24] Can be used by software to identify the presence of this peripheral.

Register 33: GPIO PrimeCell Identification 0 (GPIOCellID0), offset 0xFF0

The **GPIOCellID0**, **GPIOCellID1**, **GPIOCellID2**, and **GPIOCellID3** registers are four 8-bit wide registers, that can conceptually be treated as one 32-bit register. The register is used as a standard cross-peripheral identification system.

GPIO PrimeCell Identification 0 (GPIOCellID0)

GPIO Port A (APB) base: 0x4000.4000
 GPIO Port A (AHB) base: 0x4005.8000
 GPIO Port B (APB) base: 0x4000.5000
 GPIO Port B (AHB) base: 0x4005.9000
 GPIO Port C (APB) base: 0x4000.6000
 GPIO Port C (AHB) base: 0x4005.A000
 GPIO Port D (APB) base: 0x4000.7000
 GPIO Port D (AHB) base: 0x4005.B000
 GPIO Port E (APB) base: 0x4002.4000
 GPIO Port E (AHB) base: 0x4005.C000
 GPIO Port F (APB) base: 0x4002.5000
 GPIO Port F (AHB) base: 0x4005.D000
 GPIO Port G (APB) base: 0x4002.6000
 GPIO Port G (AHB) base: 0x4005.E000

Offset 0xFF0

Type RO, reset 0x0000.000D

	31	30	29	28	27	26	25	24	23	22	21	20	19	18	17	16
	reserved															
Type	RO	RO	RO	RO	RO	RO	RO	RO	RO	RO	RO	RO	RO	RO	RO	RO
Reset	0	0	0	0	0	0	0	0	0	0	0	0	0	0	0	0
	15	14	13	12	11	10	9	8	7	6	5	4	3	2	1	0
	reserved								CID0							
Type	RO	RO	RO	RO	RO	RO	RO	RO	RO	RO	RO	RO	RO	RO	RO	RO
Reset	0	0	0	0	0	0	0	0	0	0	0	0	1	1	0	1

Bit/Field	Name	Type	Reset	Description
31:8	reserved	RO	0x0000.00	Software should not rely on the value of a reserved bit. To provide compatibility with future products, the value of a reserved bit should be preserved across a read-modify-write operation.
7:0	CID0	RO	0x0D	GPIO PrimeCell ID Register [7:0] Provides software a standard cross-peripheral identification system.

Register 34: GPIO PrimeCell Identification 1 (GPIOCellID1), offset 0xFF4

The **GPIOCellID0**, **GPIOCellID1**, **GPIOCellID2**, and **GPIOCellID3** registers are four 8-bit wide registers, that can conceptually be treated as one 32-bit register. The register is used as a standard cross-peripheral identification system.

GPIO PrimeCell Identification 1 (GPIOCellID1)

GPIO Port A (APB) base: 0x4000.4000
 GPIO Port A (AHB) base: 0x4005.8000
 GPIO Port B (APB) base: 0x4000.5000
 GPIO Port B (AHB) base: 0x4005.9000
 GPIO Port C (APB) base: 0x4000.6000
 GPIO Port C (AHB) base: 0x4005.A000
 GPIO Port D (APB) base: 0x4000.7000
 GPIO Port D (AHB) base: 0x4005.B000
 GPIO Port E (APB) base: 0x4002.4000
 GPIO Port E (AHB) base: 0x4005.C000
 GPIO Port F (APB) base: 0x4002.5000
 GPIO Port F (AHB) base: 0x4005.D000
 GPIO Port G (APB) base: 0x4002.6000
 GPIO Port G (AHB) base: 0x4005.E000
 Offset 0xFF4
 Type RO, reset 0x0000.00F0

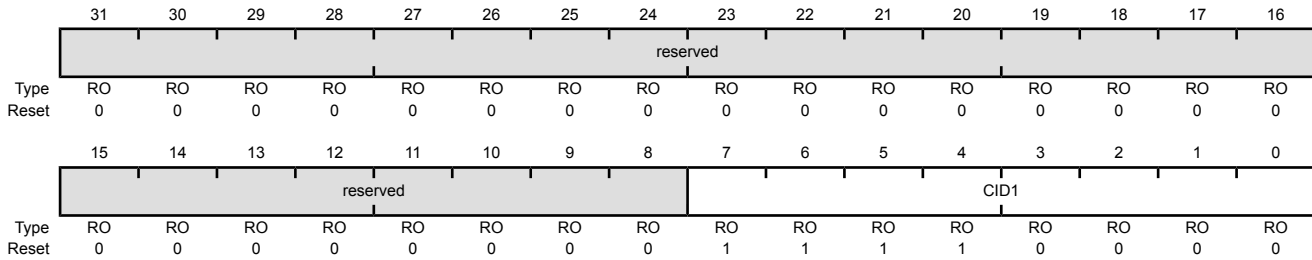

Bit/Field	Name	Type	Reset	Description
31:8	reserved	RO	0x0000.00	Software should not rely on the value of a reserved bit. To provide compatibility with future products, the value of a reserved bit should be preserved across a read-modify-write operation.
7:0	CID1	RO	0xF0	GPIO PrimeCell ID Register [15:8] Provides software a standard cross-peripheral identification system.

Register 35: GPIO PrimeCell Identification 2 (GPIOCellID2), offset 0xFF8

The **GPIOCellID0**, **GPIOCellID1**, **GPIOCellID2**, and **GPIOCellID3** registers are four 8-bit wide registers, that can conceptually be treated as one 32-bit register. The register is used as a standard cross-peripheral identification system.

GPIO PrimeCell Identification 2 (GPIOCellID2)

GPIO Port A (APB) base: 0x4000.4000
 GPIO Port A (AHB) base: 0x4005.8000
 GPIO Port B (APB) base: 0x4000.5000
 GPIO Port B (AHB) base: 0x4005.9000
 GPIO Port C (APB) base: 0x4000.6000
 GPIO Port C (AHB) base: 0x4005.A000
 GPIO Port D (APB) base: 0x4000.7000
 GPIO Port D (AHB) base: 0x4005.B000
 GPIO Port E (APB) base: 0x4002.4000
 GPIO Port E (AHB) base: 0x4005.C000
 GPIO Port F (APB) base: 0x4002.5000
 GPIO Port F (AHB) base: 0x4005.D000
 GPIO Port G (APB) base: 0x4002.6000
 GPIO Port G (AHB) base: 0x4005.E000

Offset 0xFF8

Type RO, reset 0x0000.0005

	31	30	29	28	27	26	25	24	23	22	21	20	19	18	17	16
	reserved															
Type	RO	RO	RO	RO	RO	RO	RO	RO	RO	RO	RO	RO	RO	RO	RO	RO
Reset	0	0	0	0	0	0	0	0	0	0	0	0	0	0	0	0
	15	14	13	12	11	10	9	8	7	6	5	4	3	2	1	0
	reserved								CID2							
Type	RO	RO	RO	RO	RO	RO	RO	RO	RO	RO	RO	RO	RO	RO	RO	RO
Reset	0	0	0	0	0	0	0	0	0	0	0	0	0	1	0	1

Bit/Field	Name	Type	Reset	Description
31:8	reserved	RO	0x0000.00	Software should not rely on the value of a reserved bit. To provide compatibility with future products, the value of a reserved bit should be preserved across a read-modify-write operation.
7:0	CID2	RO	0x05	GPIO PrimeCell ID Register [23:16] Provides software a standard cross-peripheral identification system.

Register 36: GPIO PrimeCell Identification 3 (GPIOCellID3), offset 0xFFC

The **GPIOCellID0**, **GPIOCellID1**, **GPIOCellID2**, and **GPIOCellID3** registers are four 8-bit wide registers, that can conceptually be treated as one 32-bit register. The register is used as a standard cross-peripheral identification system.

GPIO PrimeCell Identification 3 (GPIOCellID3)

GPIO Port A (APB) base: 0x4000.4000
 GPIO Port A (AHB) base: 0x4005.8000
 GPIO Port B (APB) base: 0x4000.5000
 GPIO Port B (AHB) base: 0x4005.9000
 GPIO Port C (APB) base: 0x4000.6000
 GPIO Port C (AHB) base: 0x4005.A000
 GPIO Port D (APB) base: 0x4000.7000
 GPIO Port D (AHB) base: 0x4005.B000
 GPIO Port E (APB) base: 0x4002.4000
 GPIO Port E (AHB) base: 0x4005.C000
 GPIO Port F (APB) base: 0x4002.5000
 GPIO Port F (AHB) base: 0x4005.D000
 GPIO Port G (APB) base: 0x4002.6000
 GPIO Port G (AHB) base: 0x4005.E000
 Offset 0xFFC
 Type RO, reset 0x0000.00B1

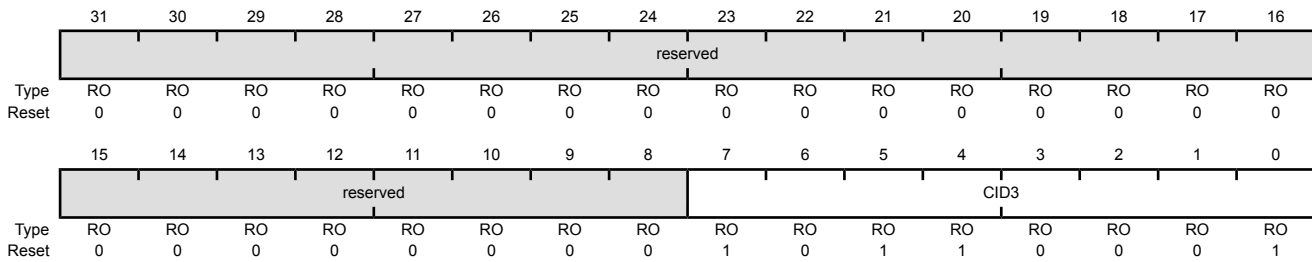

Bit/Field	Name	Type	Reset	Description
31:8	reserved	RO	0x0000.00	Software should not rely on the value of a reserved bit. To provide compatibility with future products, the value of a reserved bit should be preserved across a read-modify-write operation.
7:0	CID3	RO	0xB1	GPIO PrimeCell ID Register [31:24] Provides software a standard cross-peripheral identification system.

10 General-Purpose Timers

Programmable timers can be used to count or time external events that drive the Timer input pins. The Stellaris® General-Purpose Timer Module (GPTM) contains six 16/32-bit GPTM blocks and six 32/64-bit Wide GPTM blocks. Each 16/32-bit GPTM block provides two 16-bit timers/counters (referred to as Timer A and Timer B) that can be configured to operate independently as timers or event counters, or concatenated to operate as one 32-bit timer or one 32-bit Real-Time Clock (RTC). Each 32/64-bit Wide GPTM block provides 32-bit timers for Timer A and Timer B that can be concatenated to operate as a 64-bit timer. Timers can also be used to trigger μ DMA transfers.

In addition, timers can be used to trigger analog-to-digital conversions (ADC). The ADC trigger signals from all of the general-purpose timers are ORed together before reaching the ADC module, so only one timer should be used to trigger ADC events.

The GPT Module is one timing resource available on the Stellaris microcontrollers. Other timer resources include the System Timer (SysTick) (see 124) and the PWM timer in the PWM modules (see “PWM Timer” on page 1193).

The General-Purpose Timer Module (GPTM) contains six 16/32-bit GPTM blocks and six 32/64-bit Wide GPTM blocks with the following functional options:

- 16/32-bit operating modes:
 - 16- or 32-bit programmable one-shot timer
 - 16- or 32-bit programmable periodic timer
 - 16-bit general-purpose timer with an 8-bit prescaler
 - 32-bit Real-Time Clock (RTC) when using an external 32.768-KHz clock as the input
 - 16-bit input-edge count- or time-capture modes with an 8-bit prescaler
 - 16-bit PWM mode with an 8-bit prescaler and software-programmable output inversion of the PWM signal
- 32/64-bit operating modes:
 - 32- or 64-bit programmable one-shot timer
 - 32- or 64-bit programmable periodic timer
 - 32-bit general-purpose timer with a 16-bit prescaler
 - 64-bit Real-Time Clock (RTC) when using an external 32.768-KHz clock as the input
 - 32-bit input-edge count- or time-capture modes with a 16-bit prescaler
 - 32-bit PWM mode with a 16-bit prescaler and software-programmable output inversion of the PWM signal
- Count up or down
- Twelve 16/32-bit Capture Compare PWM pins (CCP)
- Twelve 32/64-bit Capture Compare PWM pins (CCP)

- Daisy chaining of timer modules to allow a single timer to initiate multiple timing events
- Timer synchronization allows selected timers to start counting on the same clock cycle
- ADC event trigger
- User-enabled stalling when the microcontroller asserts CPU Halt flag during debug (excluding RTC mode)
- Ability to determine the elapsed time between the assertion of the timer interrupt and entry into the interrupt service routine.
- Efficient transfers using Micro Direct Memory Access Controller (μDMA)
 - Dedicated channel for each timer
 - Burst request generated on timer interrupt

10.1 Block Diagram

In the block diagram, the specific Capture Compare PWM (CCP) pins available depend on the Stellaris device. See Table 10-1 on page 678 for the available CCP pins and their timer assignments.

Figure 10-1. GPTM Module Block Diagram

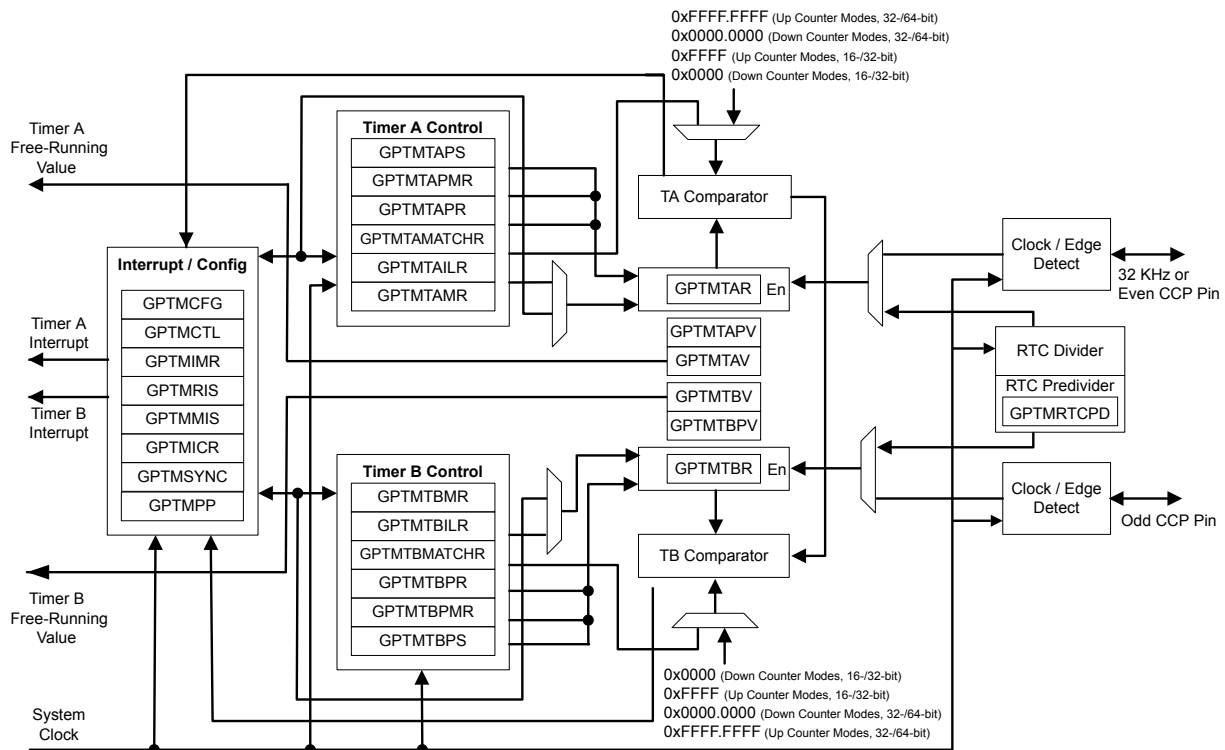

Table 10-1. Available CCP Pins

Timer	Up/Down Counter	Even CCP Pin	Odd CCP Pin
16/32-Bit Timer 0	Timer A	T0CCP0	-

Table 10-1. Available CCP Pins (continued)

Timer	Up/Down Counter	Even CCP Pin	Odd CCP Pin
	Timer B	-	T0CCP1
16/32-Bit Timer 1	Timer A	T1CCP0	-
	Timer B	-	T1CCP1
16/32-Bit Timer 2	Timer A	T2CCP0	-
	Timer B	-	T2CCP1
16/32-Bit Timer 3	Timer A	T3CCP0	-
	Timer B	-	T3CCP1
16/32-Bit Timer 4	Timer A	T4CCP0	-
	Timer B	-	T4CCP1
16/32-Bit Timer 5	Timer A	T5CCP0	-
	Timer B	-	T5CCP1
32/64-Bit Wide Timer 0	Timer A	WT0CCP0	-
	Timer B	-	WT0CCP1
32/64-Bit Wide Timer 1	Timer A	WT1CCP0	-
	Timer B	-	WT1CCP1
32/64-Bit Wide Timer 2	Timer A	WT2CCP0	-
	Timer B	-	WT2CCP1
32/64-Bit Wide Timer 3	Timer A	WT3CCP0	-
	Timer B	-	WT3CCP1
32/64-Bit Wide Timer 4	Timer A	WT4CCP0	-
	Timer B	-	WT4CCP1
32/64-Bit Wide Timer 5	Timer A	WT5CCP0	-
	Timer B	-	WT5CCP1

10.2 Signal Description

The following table lists the external signals of the GP Timer module and describes the function of each. The GP Timer signals are alternate functions for some GPIO signals and default to be GPIO signals at reset. The column in the table below titled "Pin Mux/Pin Assignment" lists the possible GPIO pin placements for these GP Timer signals. The **AFSEL** bit in the **GPIO Alternate Function Select (GPIOAFSEL)** register (page 644) should be set to choose the GP Timer function. The number in parentheses is the encoding that must be programmed into the **PMC_n** field in the **GPIO Port Control (GPIOCTL)** register (page 661) to assign the GP Timer signal to the specified GPIO port pin. For more information on configuring GPIOs, see "General-Purpose Input/Outputs (GPIOs)" on page 623.

Table 10-2. General-Purpose Timers Signals (64LQFP)

Pin Name	Pin Number	Pin Mux / Pin Assignment	Pin Type	Buffer Type ^a	Description
T0CCP0	1 28	PB6 (7) PF0 (7)	I/O	TTL	16/32-Bit Timer 0 Capture/Compare/PWM 0.
T0CCP1	4 29	PB7 (7) PF1 (7)	I/O	TTL	16/32-Bit Timer 0 Capture/Compare/PWM 1.
T1CCP0	30 58	PF2 (7) PB4 (7)	I/O	TTL	16/32-Bit Timer 1 Capture/Compare/PWM 0.

Table 10-2. General-Purpose Timers Signals (64LQFP) (continued)

Pin Name	Pin Number	Pin Mux / Pin Assignment	Pin Type	Buffer Type ^a	Description
T1CCP1	31 57	PF3 (7) PB5 (7)	I/O	TTL	16/32-Bit Timer 1 Capture/Compare/PWM 1.
T2CCP0	5 45	PF4 (7) PB0 (7)	I/O	TTL	16/32-Bit Timer 2 Capture/Compare/PWM 0.
T2CCP1	46	PB1 (7)	I/O	TTL	16/32-Bit Timer 2 Capture/Compare/PWM 1.
T3CCP0	47	PB2 (7)	I/O	TTL	16/32-Bit Timer 3 Capture/Compare/PWM 0.
T3CCP1	48	PB3 (7)	I/O	TTL	16/32-Bit Timer 3 Capture/Compare/PWM 1.
T4CCP0	37 52	PG0 (7) PC0 (7)	I/O	TTL	16/32-Bit Timer 4 Capture/Compare/PWM 0.
T4CCP1	36 51	PG1 (7) PC1 (7)	I/O	TTL	16/32-Bit Timer 4 Capture/Compare/PWM 1.
T5CCP0	35 50	PG2 (7) PC2 (7)	I/O	TTL	16/32-Bit Timer 5 Capture/Compare/PWM 0.
T5CCP1	34 49	PG3 (7) PC3 (7)	I/O	TTL	16/32-Bit Timer 5 Capture/Compare/PWM 1.
WT0CCP0	16 33	PC4 (7) PG4 (7)	I/O	TTL	32/64-Bit Wide Timer 0 Capture/Compare/PWM 0.
WT0CCP1	15 32	PC5 (7) PG5 (7)	I/O	TTL	32/64-Bit Wide Timer 0 Capture/Compare/PWM 1.
WT1CCP0	14	PC6 (7)	I/O	TTL	32/64-Bit Wide Timer 1 Capture/Compare/PWM 0.
WT1CCP1	13	PC7 (7)	I/O	TTL	32/64-Bit Wide Timer 1 Capture/Compare/PWM 1.
WT2CCP0	61	PD0 (7)	I/O	TTL	32/64-Bit Wide Timer 2 Capture/Compare/PWM 0.
WT2CCP1	62	PD1 (7)	I/O	TTL	32/64-Bit Wide Timer 2 Capture/Compare/PWM 1.
WT3CCP0	63	PD2 (7)	I/O	TTL	32/64-Bit Wide Timer 3 Capture/Compare/PWM 0.
WT3CCP1	64	PD3 (7)	I/O	TTL	32/64-Bit Wide Timer 3 Capture/Compare/PWM 1.
WT4CCP0	43	PD4 (7)	I/O	TTL	32/64-Bit Wide Timer 4 Capture/Compare/PWM 0.
WT4CCP1	44	PD5 (7)	I/O	TTL	32/64-Bit Wide Timer 4 Capture/Compare/PWM 1.
WT5CCP0	53	PD6 (7)	I/O	TTL	32/64-Bit Wide Timer 5 Capture/Compare/PWM 0.
WT5CCP1	10	PD7 (7)	I/O	TTL	32/64-Bit Wide Timer 5 Capture/Compare/PWM 1.

a. The TTL designation indicates the pin has TTL-compatible voltage levels.

10.3 Functional Description

The main components of each GPTM block are two free-running up/down counters (referred to as Timer A and Timer B), two match registers, two prescaler match registers, two shadow registers, and two load/initialization registers and their associated control functions. The exact functionality of each GPTM is controlled by software and configured through the register interface. Timer A and Timer B can be used individually, in which case they have a 16-bit counting range for the 16/32-bit GPTM blocks and a 32-bit counting range for 32/64-bit Wide GPTM blocks. In addition, Timer A and Timer B can be concatenated to provide a 32-bit counting range for the 16/32-bit GPTM blocks and a 64-bit counting range for the 32/64-bit Wide GPTM blocks. Note that the prescaler can only be used when the timers are used individually.

The available modes for each GPTM block are shown in Table 10-3 on page 681. Note that when counting down in one-shot or periodic modes, the prescaler acts as a true prescaler and contains the least-significant bits of the count. When counting up in one-shot or periodic modes, the prescaler acts as a timer extension and holds the most-significant bits of the count. In input edge count, input

edge time and PWM mode, the prescaler always acts as a timer extension, regardless of the count direction.

Table 10-3. General-Purpose Timer Capabilities

Mode	Timer Use	Count Direction	Counter Size		Prescaler Size ^a		Prescaler Behavior (Count Direction)
			16/32-bit GPTM	32/64-bit Wide GPTM	16/32-bit GPTM	32/64-bit Wide GPTM	
One-shot	Individual	Up or Down	16-bit	32-bit	8-bit	16-bit	Timer Extension (Up), Prescaler (Down)
	Concatenated	Up or Down	32-bit	64-bit	-	-	N/A
Periodic	Individual	Up or Down	16-bit	32-bit	8-bit	16-bit	Timer Extension (Up), Prescaler (Down)
	Concatenated	Up or Down	32-bit	64-bit	-	-	N/A
RTC	Concatenated	Up	32-bit	64-bit	-	-	N/A
Edge Count	Individual	Up or Down	16-bit	32-bit	8-bit	16-bit	Timer Extension (Both)
Edge Time	Individual	Up or Down	16-bit	32-bit	8-bit	16-bit	Timer Extension (Both)
PWM	Individual	Down	16-bit	32-bit	8-bit	16-bit	Timer Extension

a. The prescaler is only available when the timers are used individually

Software configures the GPTM using the **GPTM Configuration (GPTMCFG)** register (see page 700), the **GPTM Timer A Mode (GPTMTAMR)** register (see page 702), and the **GPTM Timer B Mode (GPTMTBMR)** register (see page 706). When in one of the concatenated modes, Timer A and Timer B can only operate in one mode. However, when configured in an individual mode, Timer A and Timer B can be independently configured in any combination of the individual modes.

10.3.1 GPTM Reset Conditions

After reset has been applied to the GPTM module, the module is in an inactive state, and all control registers are cleared and in their default states. Counters Timer A and Timer B are initialized to all 1s, along with their corresponding load registers: the **GPTM Timer A Interval Load (GPTMTAILR)** register (see page 729) and the **GPTM Timer B Interval Load (GPTMTBILR)** register (see page 730) and shadow registers: the **GPTM Timer A Value (GPTMTAV)** register (see page 739) and the **GPTM Timer B Value (GPTMTBV)** register (see page 740). The prescale counters are initialized to 0x00: the **GPTM Timer A Prescale (GPTMTAPR)** register (see page 733), the **GPTM Timer B Prescale (GPTMTBPR)** register (see page 734), the **GPTM Timer A Prescale Snapshot (GPTMTAPS)** register (see page 742), the **GPTM Timer B Prescale Snapshot (GPTMTBPS)** register (see page 743), the **GPTM Timer A Prescale Value (GPTMTAPV)** register (see page 744), and the **GPTM Timer B Prescale Value (GPTMTBPV)** register (see page 745).

10.3.2 Timer Modes

This section describes the operation of the various timer modes. When using Timer A and Timer B in concatenated mode, only the Timer A control and status bits must be used; there is no need to use Timer B control and status bits. The GPTM is placed into individual/split mode by writing a value of 0x4 to the **GPTM Configuration (GPTMCFG)** register (see page 700). In the following sections, the variable "n" is used in bit field and register names to imply either a Timer A function or a Timer B function. Throughout this section, the timeout event in down-count mode is 0x0 and in up-count mode is the value in the **GPTM Timer n Interval Load (GPTMTnILR)** and the optional **GPTM Timer n Prescale (GPTMTnPR)** registers.

10.3.2.1 One-Shot/Periodic Timer Mode

The selection of one-shot or periodic mode is determined by the value written to the T_{nMR} field of the **GPTM Timer n Mode (GPTMTnMR)** register (see page 702). The timer is configured to count up or down using the T_{nCDIR} bit in the **GPTMTnMR** register.

When software sets the T_{nEN} bit in the **GPTM Control (GPTMCTL)** register (see page 710), the timer begins counting up from 0x0 or down from its preloaded value. Alternatively, if the T_{nWOT} bit is set in the **GPTMTnMR** register, once the T_{nEN} bit is set, the timer waits for a trigger to begin counting (see “Wait-for-Trigger Mode” on page 691). Table 10-4 on page 682 shows the values that are loaded into the timer registers when the timer is enabled.

Table 10-4. Counter Values When the Timer is Enabled in Periodic or One-Shot Modes

Register	Count Down Mode	Count Up Mode
T_{nR}	GPTMTnILR	0x0
T_{nV}	GPTMTnILR	0x0
T_{nPS}	GPTMTnPR in individual mode; not available in concatenated mode	0x0 in individual mode; not available in concatenated mode
T_{nPV}	GPTMTnPR in individual mode; not available in concatenated mode	0x0 in individual mode; not available in concatenated mode

When the timer is counting down and it reaches the timeout event (0x0), the timer reloads its start value from the **GPTMTnILR** and the **GPTMTnPR** registers on the next cycle. When the timer is counting up and it reaches the timeout event (the value in the **GPTMTnILR** and the optional **GPTMTnPR** registers), the timer reloads with 0x0. If configured to be a one-shot timer, the timer stops counting and clears the T_{nEN} bit in the **GPTMCTL** register. If configured as a periodic timer, the timer starts counting again on the next cycle.

In periodic, snap-shot mode (T_{nMR} field is 0x2 and the T_{nSNAPS} bit is set in the **GPTMTnMR** register), the value of the timer at the time-out event is loaded into the **GPTMTnR** register and the value of the prescaler is loaded into the **GPTMTnPS** register. The free-running counter value is shown in the **GPTMTnV** register and the free-running prescaler value is shown in the **GPTMTnPV** register. In this manner, software can determine the time elapsed from the interrupt assertion to the ISR entry by examining the snapshot values and the current value of the free-running timer. Snapshot mode is not available when the timer is configured in one-shot mode.

In addition to reloading the count value, the GPTM generates interrupts and triggers when it reaches the time-out event. The GPTM sets the T_{nTORIS} bit in the **GPTM Raw Interrupt Status (GPTMRIS)** register (see page 721), and holds it until it is cleared by writing the **GPTM Interrupt Clear (GPTMICR)** register (see page 727). If the time-out interrupt is enabled in the **GPTM Interrupt Mask (GPTMIMR)** register (see page 718), the GPTM also sets the T_{nTOMIS} bit in the **GPTM Masked Interrupt Status (GPTMMIS)** register (see page 724). By setting the T_{nMIE} bit in the **GPTMTnMR** register, an interrupt condition can also be generated when the Timer value equals the value loaded into the **GPTM Timer n Match (GPTMTnMATCHR)** and **GPTM Timer n Prescale Match (GPTMTnPMR)** registers. This interrupt has the same status, masking, and clearing functions as the time-out interrupt, but uses the match interrupt bits instead (for example, the raw interrupt status is monitored via T_{nMRIS} bit in the **GPTM Raw Interrupt Status (GPTMRIS)** register). Note that the interrupt status bits are not updated by the hardware unless the T_{nMIE} bit in the **GPTMTnMR** register is set, which is different than the behavior for the time-out interrupt. The ADC trigger is enabled by setting the T_{nOTE} bit in **GPTMCTL**. The μ DMA trigger is enabled by configuring and enabling the appropriate μ DMA channel. See “Channel Configuration” on page 563.

If software updates the **GPTMTnILR** or the **GPTMTnPR** register while the counter is counting down, the counter loads the new value on the next clock cycle and continues counting from the new value

if the T_{nILD} bit in the **GPTMTnMR** register is clear. If the T_{nILD} bit is set, the counter loads the new value after the next timeout. If software updates the **GPTMTnILR** or the **GPTMTnPR** register while the counter is counting up, the timeout event is changed on the next cycle to the new value. If software updates the **GPTM Timer n Value (GPTMTnV)** register while the counter is counting up or down, the counter loads the new value on the next clock cycle and continues counting from the new value. If software updates the **GPTMTnMATCHR** or the **GPTMTnPMR** registers, the new values are reflected on the next clock cycle if the T_{nMRSU} bit in the **GPTMTnMR** register is clear. If the T_{nMRSU} bit is set, the new value don't take effect until the next timeout.

When using a 32/64-bit wide timer block in a 64-bit mode, certain registers must be accessed in the manner described in “Accessing Concatenated 32/64-Bit Wide GPTM Register Values” on page 693.

If the T_{nSTALL} bit in the **GPTMCTL** register is set, the timer freezes counting while the processor is halted by the debugger. The timer resumes counting when the processor resumes execution.

The following table shows a variety of configurations for a 16-bit free-running timer while using the prescaler. All values assume an 80-MHz clock with $T_c=12.5$ ns (clock period). The prescaler can only be used when a 16/32-bit timer is configured in 16-bit mode and when a 32/64-bit timer is configured in 32-bit mode.

Table 10-5. 16-Bit Timer With Prescaler Configurations

Prescale (8-bit value)	# of Timer Clocks (T_c) ^a	Max Time	Units
00000000	1	0.8192	ms
00000001	2	1.6384	ms
00000010	3	2.4576	ms
-----	--	--	--
11111101	254	208.0768	ms
11111110	255	208.896	ms
11111111	256	209.7152	ms

a. T_c is the clock period.

The following table shows a variety of configurations for a 32-bit free-running timer using the prescaler while configured in 32/64-bit mode. All values assume an 80-MHz clock with $T_c=12.5$ ns (clock period).

Table 10-6. 32-Bit Timer (configured in 32/64-bit mode) With Prescaler Configurations

Prescale (16-bit value)	# of Timer Clocks (T_c) ^a	Max Time	Units
0x0000	1	53.687	s
0x0001	2	107.374	s
0x0002	3	214.748	s
-----	--	--	--
0xFFFFD	65534	0.879	10^6 s
0xFFFFE	65535	1.759	10^6 s
0xFFFFF	65536	3.518	10^6 s

a. T_c is the clock period.

10.3.2.2 Real-Time Clock Timer Mode

In Real-Time Clock (RTC) mode, the concatenated versions of the Timer A and Timer B registers are configured as an up-counter. When RTC mode is selected for the first time after reset, the

counter is loaded with a value of 0x1. All subsequent load values must be written to the **GPTM Timer n Interval Load (GPTMTnILR)** registers (see page 729). Table 10-7 on page 684 shows the values that are loaded into the timer registers when the timer is enabled.

Table 10-7. Counter Values When the Timer is Enabled in RTC Mode

Register	Count Down Mode	Count Up Mode
TnR	Not available	0x1
TnV	Not available	0x1
TnPS	Not available	Not available
TnPV	Not available	Not available

The input clock on a CCP0 input is required to be 32.768 KHz in RTC mode. The clock signal is then divided down to a 1-Hz rate and is passed along to the input of the counter.

When software writes the **TAEN** bit in the **GPTMCTL** register, the counter starts counting up from its preloaded value of 0x1. When the current count value matches the preloaded value in the **GPTMTnMRTATCHR** registers, the GPTM asserts the **RTCRES** bit in **GPTMRIS** and continues counting until either a hardware reset, or it is disabled by software (clearing the **TAEN** bit). When the timer value reaches the terminal count, the timer rolls over and continues counting up from 0x0. If the RTC interrupt is enabled in **GPTMIMR**, the GPTM also sets the **RTCMIS** bit in **GPTMMIS** and generates a controller interrupt. The status flags are cleared by writing the **RTCCINT** bit in **GPTMICR**.

In this mode, the **GPTMTnR** and **GPTMTnV** registers always have the same value.

When using a 32/64-bit wide timer block in a RTC mode, certain registers must be accessed in the manner described in “Accessing Concatenated 32/64-Bit Wide GPTM Register Values” on page 693.

The value of the RTC predivider can be read in the **GPTM RTC Predivide (GPTMRTCPD)** register. To ensure that the RTC value is coherent, software should follow the process detailed in Figure 10-2 on page 685.

Figure 10-2. Reading the RTC Value

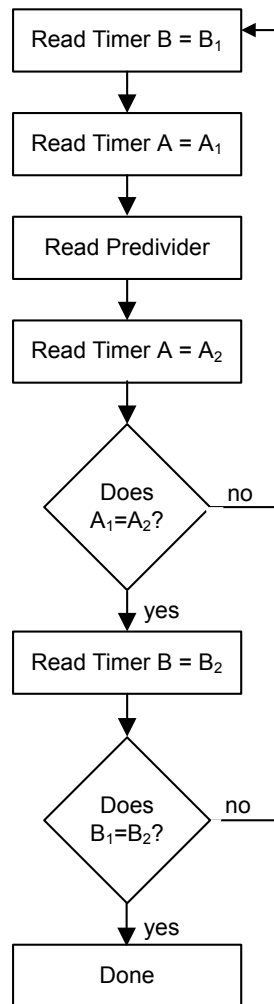

In addition to generating interrupts, a μ DMA trigger can be generated. The μ DMA trigger is enabled by configuring and enabling the appropriate μ DMA channel. See “Channel Configuration” on page 563.

If the `TASTALL` bit in the `GPTMCTL` register is set, the timer does not freeze when the processor is halted by the debugger if the `RTCEN` bit is set in `GPTMCTL`.

10.3.2.3 Input Edge-Count Mode

Note: For rising-edge detection, the input signal must be High for at least two system clock periods following the rising edge. Similarly, for falling-edge detection, the input signal must be Low for at least two system clock periods following the falling edge. Based on this criteria, the maximum input frequency for edge detection is 1/4 of the system frequency.

In Edge-Count mode, the timer is configured as a 24-bit or 48-bit up- or down-counter including the optional prescaler with the upper count value stored in the **GPTM Timer n Prescale (GPTMTnPR)** register and the lower bits in the **GPTMTnR** register. In this mode, the timer is capable of capturing three types of events: rising edge, falling edge, or both. To place the timer in Edge-Count mode, the `TnCMR` bit of the **GPTMTnMR** register must be cleared. The type of edge that the timer counts is determined by the `TnEVENT` fields of the **GPTMCTL** register. During initialization in down-count mode, the **GPTMTnMATCHR** and **GPTMTnPMR** registers are configured so that the difference

between the value in the **GPTMTnILR** and **GPTMTnPR** registers and the **GPTMTnMATCHR** and **GPTMTnPMR** registers equals the number of edge events that must be counted. In up-count mode, the timer counts from 0x0 to the value in the **GPTMTnMATCHR** and **GPTMTnPMR** registers. Table 10-8 on page 686 shows the values that are loaded into the timer registers when the timer is enabled.

Table 10-8. Counter Values When the Timer is Enabled in Input Edge-Count Mode

Register	Count Down Mode	Count Up Mode
TnR	GPTMTnILR	0x0
TnV	GPTMTnILR	0x0
TnPS	GPTMTnPR	0x0
TnPV	GPTMTnPR	0x0

When software writes the **TnEN** bit in the **GPTM Control (GPTMCTL)** register, the timer is enabled for event capture. Each input event on the CCP pin decrements or increments the counter by 1 until the event count matches **GPTMTnMATCHR** and **GPTMTnPMR**. When the counts match, the GPTM asserts the **CnMRIS** bit in the **GPTM Raw Interrupt Status (GPTMRIS)** register, and holds it until it is cleared by writing the **GPTM Interrupt Clear (GPTMICR)** register. If the capture mode match interrupt is enabled in the **GPTM Interrupt Mask (GPTMIMR)** register, the GPTM also sets the **CnMMIS** bit in the **GPTM Masked Interrupt Status (GPTMMIS)** register. In this mode, the **GPTMTnR** and **GPTMTnPS** registers hold the count of the input events while the **GPTMTnV** and **GPTMTnPV** registers hold the free-running timer value and the free-running prescaler value.

In addition to generating interrupts, an ADC and/or a μ DMA trigger can be generated. The ADC trigger is enabled by setting the **TnOTE** bit in **GPTMCTL**. The μ DMA trigger is enabled by configuring and enabling the appropriate μ DMA channel. See “Channel Configuration” on page 563.

After the match value is reached in down-count mode, the counter is then reloaded using the value in **GPTMTnILR** and **GPTMTnPR** registers, and stopped because the GPTM automatically clears the **TnEN** bit in the **GPTMCTL** register. Once the event count has been reached, all further events are ignored until **TnEN** is re-enabled by software. In up-count mode, the timer is reloaded with 0x0 and continues counting.

Figure 10-3 on page 687 shows how Input Edge-Count mode works. In this case, the timer start value is set to **GPTMTnILR** = 0x000A and the match value is set to **GPTMTnMATCHR** = 0x0006 so that four edge events are counted. The counter is configured to detect both edges of the input signal.

Note that the last two edges are not counted because the timer automatically clears the **TnEN** bit after the current count matches the value in the **GPTMTnMATCHR** register.

Figure 10-3. Input Edge-Count Mode Example, Counting Down

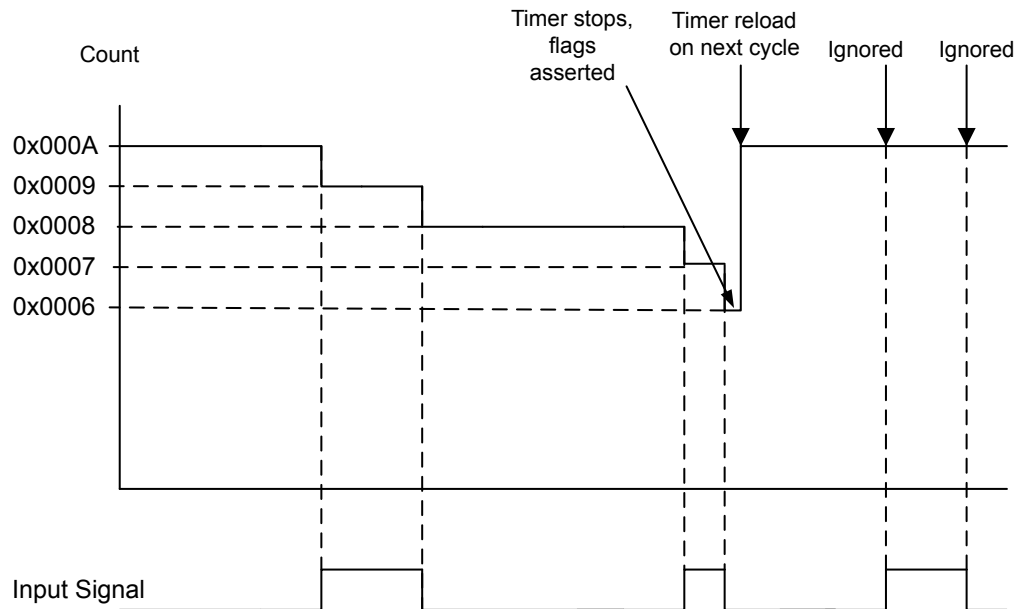

10.3.2.4 Input Edge-Time Mode

Note: For rising-edge detection, the input signal must be High for at least two system clock periods following the rising edge. Similarly, for falling edge detection, the input signal must be Low for at least two system clock periods following the falling edge. Based on this criteria, the maximum input frequency for edge detection is 1/4 of the system frequency.

In Edge-Time mode, the timer is configured as a 24-bit or 48-bit up- or down-counter including the optional prescaler with the upper timer value stored in the **GPTMTnPR** register and the lower bits in the **GPTMTnILR** register. In this mode, the timer is initialized to the value loaded in the **GPTMTnILR** and **GPTMTnPR** registers when counting down and 0x0 when counting up. The timer is capable of capturing three types of events: rising edge, falling edge, or both. The timer is placed into Edge-Time mode by setting the **TnCMR** bit in the **GPTMTnMR** register, and the type of event that the timer captures is determined by the **TnEVENT** fields of the **GPTMCTL** register. Table 10-9 on page 687 shows the values that are loaded into the timer registers when the timer is enabled.

Table 10-9. Counter Values When the Timer is Enabled in Input Event-Count Mode

Register	Count Down Mode	Count Up Mode
TnR	GPTMTnILR	0x0
TnV	GPTMTnILR	0x0
TnPS	GPTMTnPR	0x0
TnPV	GPTMTnPR	0x0

When software writes the **TnEN** bit in the **GPTMCTL** register, the timer is enabled for event capture. When the selected input event is detected, the current timer counter value is captured in the **GPTMTnR** and **GPTMTnPS** registers and is available to be read by the microcontroller. The GPTM then asserts the **CnERIS** bit in the **GPTM Raw Interrupt Status (GPTMRIS)** register, and holds it until it is cleared by writing the **GPTM Interrupt Clear (GPTMICR)** register. If the capture mode event interrupt is enabled in the **GPTM Interrupt Mask (GPTMIMR)** register, the GPTM also sets the **CnEMIS** bit in the **GPTM Masked Interrupt Status (GPTMMIS)** register. In this mode, the

GPTMTnR and **GPTMTnPS** registers hold the time at which the selected input event occurred while the **GPTMTnV** and **GPTMTnPV** registers hold the free-running timer value and the free-running prescaler value. These registers can be read to determine the time that elapsed between the interrupt assertion and the entry into the ISR.

In addition to generating interrupts, an ADC and/or a μ DMA trigger can be generated. The ADC trigger is enabled by setting the T_{nOTE} bit in **GPTMCTL**. The μ DMA trigger is enabled by configuring and enabling the appropriate μ DMA channel. See “Channel Configuration” on page 563.

After an event has been captured, the timer does not stop counting. It continues to count until the T_{nEN} bit is cleared. When the timer reaches the timeout value, it is reloaded with 0x0 in up-count mode and the value from the **GPTMTnILR** and **GPTMTnPR** registers in down-count mode.

Figure 10-4 on page 688 shows how input edge timing mode works. In the diagram, it is assumed that the start value of the timer is the default value of 0xFFFF, and the timer is configured to capture rising edge events.

Each time a rising edge event is detected, the current count value is loaded into the **GPTMTnR** and **GPTMTnPS** registers, and is held there until another rising edge is detected (at which point the new count value is loaded into the **GPTMTnR** and **GPTMTnPS** registers).

Figure 10-4. 16-Bit Input Edge-Time Mode Example

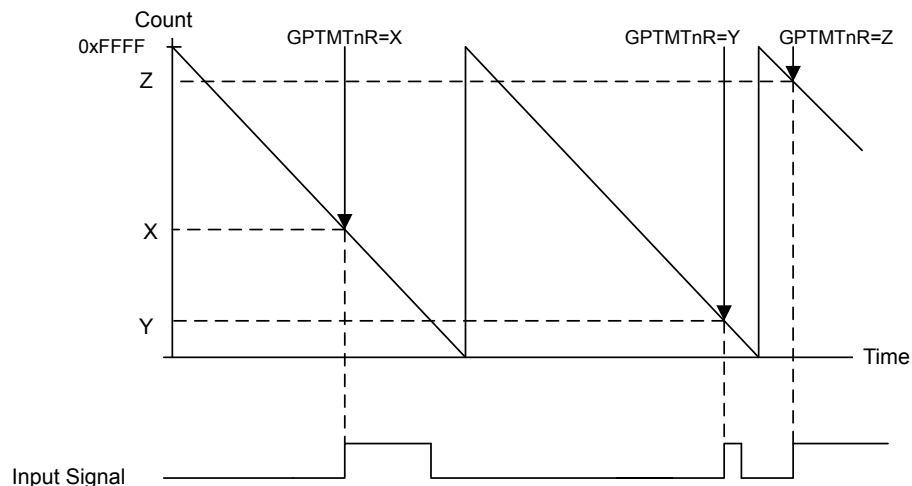

Note: When operating in Edge-time mode, the counter uses a modulo 2^{24} count if prescaler is enabled or 2^{16} , if not. If there is a possibility the edge could take longer than the count, then another timer can be implemented to ensure detection of the missed edge.

10.3.2.5 PWM Mode

The GPTM supports a simple PWM generation mode. In PWM mode, the timer is configured as a 24-bit or 48-bit down-counter with a start value (and thus period) defined by the **GPTMTnILR** and **GPTMTnPR** registers. In this mode, the PWM frequency and period are synchronous events and therefore guaranteed to be glitch free. PWM mode is enabled with the **GPTMTnMR** register by setting the T_{nAMS} bit to 0x1, the T_{nCMR} bit to 0x0, and the T_{nMR} field to 0x1 or 0x2. Table 10-10 on page 689 shows the values that are loaded into the timer registers when the timer is enabled.

Table 10-10. Counter Values When the Timer is Enabled in PWM Mode

Register	Count Down Mode	Count Up Mode
GPTMTnR	GPTMTnILR	Not available
GPTMTnV	GPTMTnILR	Not available
GPTMTnPS	GPTMTnPR	Not available
GPTMTnPV	GPTMTnPR	Not available

When software writes the T_{nEN} bit in the **GPTMCTL** register, the counter begins counting down until it reaches the 0x0 state. Alternatively, if the T_{nWOT} bit is set in the **GPTMTnMR** register, once the T_{nEN} bit is set, the timer waits for a trigger to begin counting (see “Wait-for-Trigger Mode” on page 691). On the next counter cycle in periodic mode, the counter reloads its start value from the **GPTMTnILR** and **GPTMTnPR** registers and continues counting until disabled by software clearing the T_{nEN} bit in the **GPTMCTL** register. The timer is capable of generating interrupts based on three types of events: rising edge, falling edge, or both. The event is configured by the T_{nEVENT} field of the **GPTMCTL** register, and the interrupt is enabled by setting the T_{nPWMIE} bit in the **GPTMTnMR** register. When the event occurs, the C_{nERIS} bit is set in the **GPTM Raw Interrupt Status (GPTMRIS)** register, and holds it until it is cleared by writing the **GPTM Interrupt Clear (GPTMICR)** register. If the capture mode event interrupt is enabled in the **GPTM Interrupt Mask (GPTMIMR)** register, the GPTM also sets the C_{nEMIS} bit in the **GPTM Masked Interrupt Status (GPTMMIS)** register. Note that the interrupt status bits are not updated unless the T_{nPWMIE} bit is set.

In this mode, the **GPTMTnR** and **GPTMTnV** registers always have the same value, as do the **GPTMPnPS** and the **GPTMTnPV** registers.

The output PWM signal asserts when the counter is at the value of the **GPTMTnILR** and **GPTMTnPR** registers (its start state), and is deasserted when the counter value equals the value in the **GPTMTnMATCHR** and **GPTMTnPMR** registers. Software has the capability of inverting the output PWM signal by setting the T_{nPWML} bit in the **GPTMCTL** register.

Note: If PWM output inversion is enabled, edge detection interrupt behavior is reversed. Thus, if a positive-edge interrupt trigger has been set and the PWM inversion generates a positive edge, no event-trigger interrupt asserts. Instead, the interrupt is generated on the negative edge of the PWM signal.

Figure 10-5 on page 690 shows how to generate an output PWM with a 1-ms period and a 66% duty cycle assuming a 50-MHz input clock and $T_{nPWML} = 0$ (duty cycle would be 33% for the $T_{nPWML} = 1$ configuration). For this example, the start value is **GPTMTnILR**=0xC350 and the match value is **GPTMTnMATCHR**=0x411A.

Figure 10-5. 16-Bit PWM Mode Example

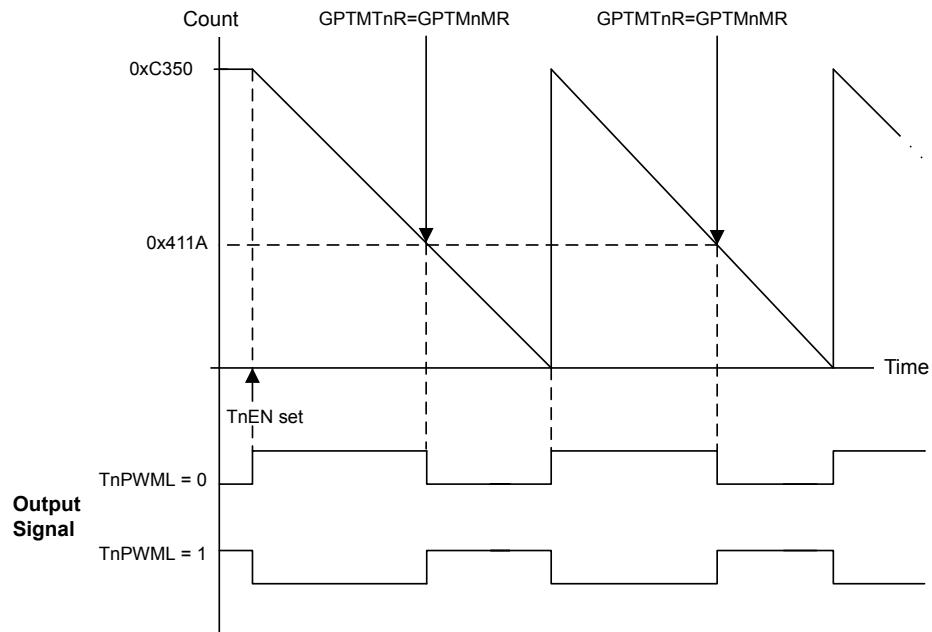

When synchronizing the timers using the **GPTMSYNC** register, the timer must be properly configured to avoid glitches on the CCP outputs. Both the **PLO** and the **MRSU** bits must be set in the **GPTMTnMR** register. Figure 10-6 on page 690 shows how the CCP output operates when the **PLO** and **MRSU** bits are set and the **GPTMTnMATCHR** value is greater than the **GPTMTnILR** value.

Figure 10-6. CCP Output, GPTMTnMATCHR > GPTMTnILR

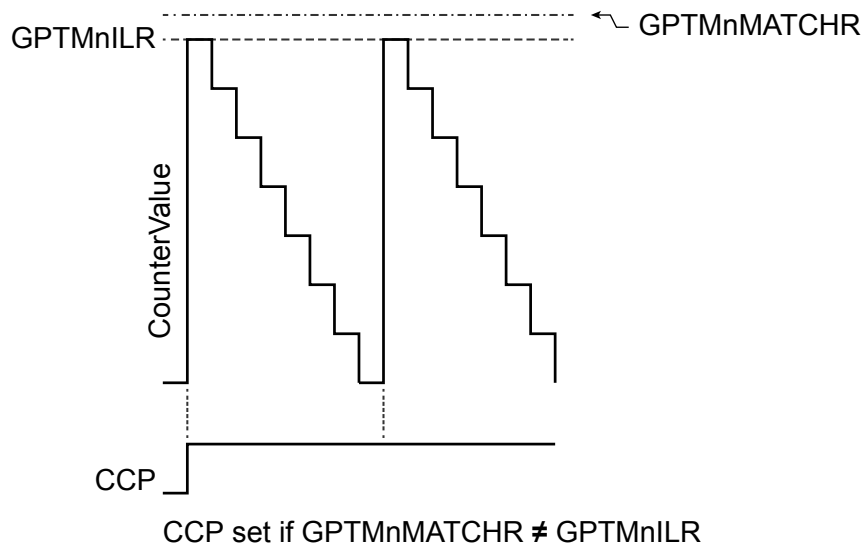

Figure 10-7 on page 691 shows how the CCP output operates when the **PLO** and **MRSU** bits are set and the **GPTMTnMATCHR** value is the same as the **GPTMTnILR** value. In this situation, if the **PLO**

bit is 0, the CCP signal goes high when the **GPTMTnILR** value is loaded and the match would be essentially ignored.

Figure 10-7. CCP Output, GPTMTnMATCHR = GPTMTnILR

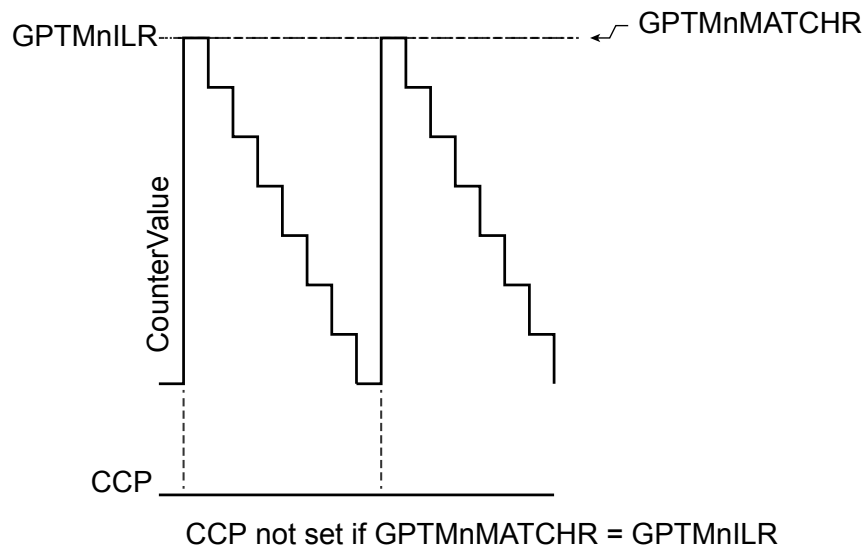
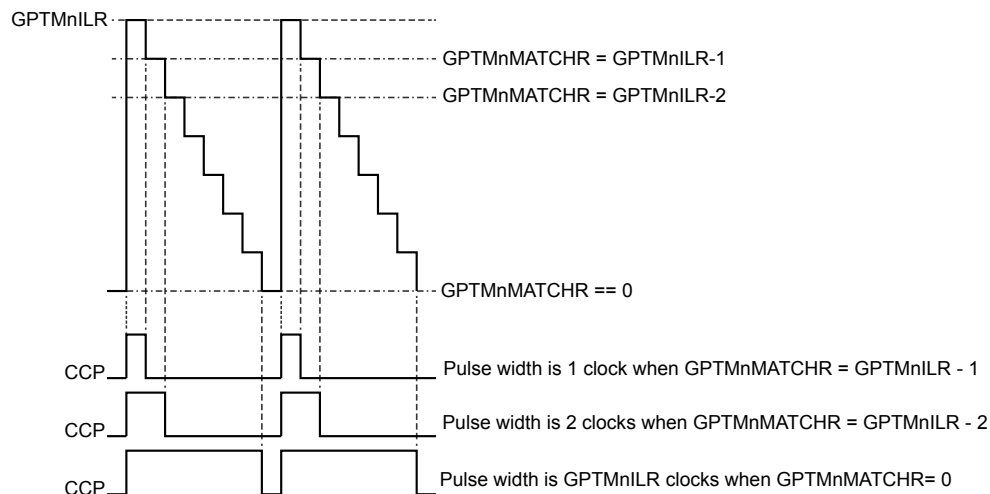

Figure 10-8 on page 691 shows how the CCP output operates when the **PLO** and **MRSU** bits are set and the **GPTMTnILR** is greater than the **GPTMTnMATCHR** value.

Figure 10-8. CCP Output, GPTMTnILR > GPTMTnMATCHR



10.3.3 Wait-for-Trigger Mode

The Wait-for-Trigger mode allows daisy chaining of the timer modules such that once configured, a single timer can initiate multiple timing events using the Timer triggers. Wait-for-Trigger mode is enabled by setting the **TnWOT** bit in the **GPTMTnMR** register. When the **TnWOT** bit is set, Timer N+1 does not begin counting until the timer in the previous position in the daisy chain (Timer N) reaches its time-out event. The daisy chain is configured such that GPTM1 always follows GPTM0, GPTM2 follows GPTM1, and so on. If Timer A is configured as a 32-bit (16/32-bit mode) or 64-bit (32/64-bit wide mode) timer (controlled by the **GPTMCFG** field in the **GPTMCFG** register), it triggers Timer A

in the next module. If Timer A is configured as a 16-bit (16/32-bit mode) or 32-bit (32/64-bit wide mode) timer, it triggers Timer B in the same module, and Timer B triggers Timer A in the next module. Care must be taken that the `TAWOT` bit is never set in `GPTM0`. Figure 10-9 on page 692 shows how the `GPTMCFG` bit affects the daisy chain. This function is valid for one-shot, periodic, and PWM modes.

Figure 10-9. Timer Daisy Chain

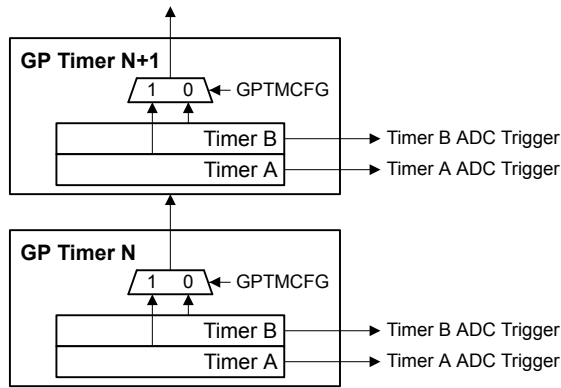

10.3.4 Synchronizing GP Timer Blocks

The **GPTM Synchronizer Control (GPTMSYNC)** register in the `GPTM0` block can be used to synchronize selected timers to begin counting at the same time. Setting a bit in the **GPTMSYNC** register causes the associated timer to perform the actions of a timeout event. An interrupt is not generated when the timers are synchronized. If a timer is being used in concatenated mode, only the bit for Timer A must be set in the **GPTMSYNC** register.

Table 10-11 on page 692 shows the actions for the timeout event performed when the timers are synchronized in the various timer modes.

Table 10-11. Timeout Actions for GPTM Modes

Mode	Count Dir	Time Out Action
32- and 64-bit One-Shot (concatenated timers)	—	N/A
32- and 64-bit Periodic (concatenated timers)	Down	Count value = ILR
	Up	Count value = 0
32- and 64-bit RTC (concatenated timers)	Up	Count value = 0
16- and 32-bit One Shot (individual/split timers)	—	N/A
16- and 32-bit Periodic (individual/split timers)	Down	Count value = ILR
	Up	Count value = 0
16- and 32-bit Edge-Count (individual/split timers)	Down	Count value = ILR
	Up	Count value = 0
16- and 32-bit Edge-Time (individual/split timers)	Down	Count value = ILR
	Up	Count value = 0
16- and 32-bit PWM	Down	Count value = ILR

10.3.5 DMA Operation

The timers each have a dedicated μ DMA channel and can provide a request signal to the μ DMA controller. The request is a burst type and occurs whenever a timer raw interrupt condition occurs. The arbitration size of the μ DMA transfer should be set to the amount of data that should be transferred whenever a timer event occurs.

For example, to transfer 256 items, 8 items at a time every 10 ms, configure a timer to generate a periodic timeout at 10 ms. Configure the μ DMA transfer for a total of 256 items, with a burst size of 8 items. Each time the timer times out, the μ DMA controller transfers 8 items, until all 256 items have been transferred.

No other special steps are needed to enable Timers for μ DMA operation. Refer to “Micro Direct Memory Access (μ DMA)” on page 559 for more details about programming the μ DMA controller.

10.3.6 Accessing Concatenated 16/32-Bit GPTM Register Values

The GPTM is placed into concatenated mode by writing a 0x0 or a 0x1 to the `GPTMCFG` bit field in the **GPTM Configuration (GPTMCFG)** register. In both configurations, certain 16/32-bit GPTM registers are concatenated to form pseudo 32-bit registers. These registers include:

- **GPTM Timer A Interval Load (GPTMTAILR)** register [15:0], see page 729
- **GPTM Timer B Interval Load (GPTMTBILR)** register [15:0], see page 730
- **GPTM Timer A (GPTMTAR)** register [15:0], see page 737
- **GPTM Timer B (GPTMTBR)** register [15:0], see page 738
- **GPTM Timer A Value (GPTMTAV)** register [15:0], see page 739
- **GPTM Timer B Value (GPTMTBV)** register [15:0], see page 740
- **GPTM Timer A Match (GPTMTAMATCHR)** register [15:0], see page 731
- **GPTM Timer B Match (GPTMTBMATCHR)** register [15:0], see page 732

In the 32-bit modes, the GPTM translates a 32-bit write access to **GPTMTAILR** into a write access to both **GPTMTAILR** and **GPTMTBILR**. The resulting word ordering for such a write operation is:

```
GPTMTBILR[15:0]:GPTMTAILR[15:0]
```

Likewise, a 32-bit read access to **GPTMTAR** returns the value:

```
GPTMTBR[15:0]:GPTMTAR[15:0]
```

A 32-bit read access to **GPTMTAV** returns the value:

```
GPTMTBV[15:0]:GPTMTAV[15:0]
```

10.3.7 Accessing Concatenated 32/64-Bit Wide GPTM Register Values

On the 32/64-bit Wide GPTM blocks, concatenated register values (64-bits and 48-bits) are not readily available as the bit width for these accesses is greater than the bus width of the processor core. In the concatenated timer modes and the individual timer modes when using the prescaler, software must perform atomic accesses for the value to be coherent. When reading timer values that are greater than 32 bits, software should follow these steps:

1. Read the appropriate Timer B register or prescaler register.
2. Read the corresponding Timer A register.
3. Re-read the Timer B register or prescaler register.
4. Compare the Timer B or prescaler values from the first and second reads. If they are the same, the timer value is coherent. If they are not the same, repeat steps 1-4 once more so that they are the same.

The following pseudo code illustrates this process:

```
high = timer_high;
low = timer_low;

if (high != timer_high); //low overflowed into high
{
    high = timer_high;
    low = timer_low;
}
```

The registers that must be read in this manner are shown below:

- 64-bit reads
 - **GPTMTAV** and **GPTMTBV**
 - **GPTMTAR** and **GPTMTBR**
- 48-bit reads
 - **GPTMTAR** and **GPTMTAPS**
 - **GPTMTBR** and **GPTMTBPS**
 - **GPTMTAV** and **GPTMTAPV**
 - **GPTMTBV** and **GPTMTBPV**

Similarly, write accesses must also be performed by writing the upper bits prior to writing the lower bits as follows:

1. Write the appropriate Timer B register or prescaler register.
2. Write the corresponding Timer A register.

The registers that must be written in this manner are shown below:

- 64-bit writes
 - **GPTMTAV** and **GPTMTBV**

- **GPTMTAMATCHR** and **GPTMTBMATCHR**
- **GPTMTAILR** and **GPTMTBILR**
- 48-bit writes
 - **GPTMTAV** and **GPTMTAPV**
 - **GPTMTBV** and **GPTMTBPV**
 - **GPTMTAMATCHR** and **GPTMTAPMR**
 - **GPTMTBMATCHR** and **GPTMTBPMR**
 - **GPTMTAILR** and **GPTMTAPR**
 - **GPTMTBILR** and **GPTMTBPR**

When writing a 64-bit value, if there are two consecutive writes to any of the registers listed above under the "64-bit writes" heading, whether the register is in Timer A or Timer B, or if a register Timer A is written prior to writing the corresponding register in Timer B, then an error is reported using the **WUERIS** bit in the **GPTMRIS** register. This error can be promoted to interrupt if it is not masked. Note that this error is not reported for the prescaler registers because use of the prescaler is optional. As a result, programmers must take care to follow the protocol outlined above.

10.4 Initialization and Configuration

To use a GPTM, the appropriate **TIMERN** bit must be set in the **RCGCTIMER** or **RCGCWTIMER** register (see page 317 and page 335). If using any CCP pins, the clock to the appropriate GPIO module must be enabled via the **RCGCGPIO** register (see page 319). To find out which GPIO port to enable, refer to Table 22-4 on page 1307. Configure the **PMCn** fields in the **GPIOPCTL** register to assign the CCP signals to the appropriate pins (see page 661 and Table 22-5 on page 1314).

This section shows module initialization and configuration examples for each of the supported timer modes.

10.4.1 One-Shot/Periodic Timer Mode

The GPTM is configured for One-Shot and Periodic modes by the following sequence:

1. Ensure the timer is disabled (the **TnEN** bit in the **GPTMCTL** register is cleared) before making any changes.
2. Write the **GPTM Configuration Register (GPTMCFG)** with a value of 0x0000.0000.
3. Configure the **TnMR** field in the **GPTM Timer n Mode Register (GPTMTnMR)**:
 - a. Write a value of 0x1 for One-Shot mode.
 - b. Write a value of 0x2 for Periodic mode.
4. Optionally configure the **TnSNAPS**, **TnWOT**, **TnMTE**, and **TnCDIR** bits in the **GPTMTnMR** register to select whether to capture the value of the free-running timer at time-out, use an external trigger to start counting, configure an additional trigger or interrupt, and count up or down.
5. Load the start value into the **GPTM Timer n Interval Load Register (GPTMTnILR)**.

6. If interrupts are required, set the appropriate bits in the **GPTM Interrupt Mask Register (GPTMIMR)**.
7. Set the **TnEN** bit in the **GPTMCTL** register to enable the timer and start counting.
8. Poll the **GPTMRIS** register or wait for the interrupt to be generated (if enabled). In both cases, the status flags are cleared by writing a 1 to the appropriate bit of the **GPTM Interrupt Clear Register (GPTMICR)**.

If the **TnMIE** bit in the **GPTMTnMR** register is set, the **RTCRES** bit in the **GPTMRIS** register is set, and the timer continues counting. In One-Shot mode, the timer stops counting after the time-out event. To re-enable the timer, repeat the sequence. A timer configured in Periodic mode reloads the timer and continues counting after the time-out event.

10.4.2 Real-Time Clock (RTC) Mode

To use the RTC mode, the timer must have a 32.768-KHz input signal on an even CCP input. To enable the RTC feature, follow these steps:

1. Ensure the timer is disabled (the **TAEN** bit is cleared) before making any changes.
2. Write the **GPTM Configuration Register (GPTMCFG)** with a value of 0x0000.0001.
3. Write the match value to the **GPTM Timer n Match Register (GPTMTnMATCHR)**.
4. Set/clear the **RTCEN** bit in the **GPTM Control Register (GPTMCTL)** as needed.
5. If interrupts are required, set the **RTCIM** bit in the **GPTM Interrupt Mask Register (GPTMIMR)**.
6. Set the **TAEN** bit in the **GPTMCTL** register to enable the timer and start counting.

When the timer count equals the value in the **GPTMTnMATCHR** register, the GPTM asserts the **RTCRES** bit in the **GPTMRIS** register and continues counting until Timer A is disabled or a hardware reset. The interrupt is cleared by writing the **RTCCINT** bit in the **GPTMICR** register.

10.4.3 Input Edge-Count Mode

A timer is configured to Input Edge-Count mode by the following sequence:

1. Ensure the timer is disabled (the **TnEN** bit is cleared) before making any changes.
2. Write the **GPTM Configuration (GPTMCFG)** register with a value of 0x0000.0004.
3. In the **GPTM Timer Mode (GPTMTnMR)** register, write the **TnCMR** field to 0x0 and the **TnMR** field to 0x3.
4. Configure the type of event(s) that the timer captures by writing the **TnEVENT** field of the **GPTM Control (GPTMCTL)** register.
5. If a prescaler is to be used, write the prescale value to the **GPTM Timer n Prescale Register (GPTMTnPR)**.
6. Load the timer start value into the **GPTM Timer n Interval Load (GPTMTnILR)** register.
7. Load the event count into the **GPTM Timer n Match (GPTMTnMATCHR)** register.

8. If interrupts are required, set the $CnMIM$ bit in the **GPTM Interrupt Mask (GPTMIMR)** register.
9. Set the $TnEN$ bit in the **GPTMCTL** register to enable the timer and begin waiting for edge events.
10. Poll the $CnMRIS$ bit in the **GPTMRIS** register or wait for the interrupt to be generated (if enabled). In both cases, the status flags are cleared by writing a 1 to the $CnMCINT$ bit of the **GPTM Interrupt Clear (GPTMICR)** register.

When counting down in Input Edge-Count Mode, the timer stops after the programmed number of edge events has been detected. To re-enable the timer, ensure that the $TnEN$ bit is cleared and repeat #4 on page 696 through #9 on page 697.

10.4.4 Input Edge Timing Mode

A timer is configured to Input Edge Timing mode by the following sequence:

1. Ensure the timer is disabled (the $TnEN$ bit is cleared) before making any changes.
2. Write the **GPTM Configuration (GPTMCFG)** register with a value of 0x0000.0004.
3. In the **GPTM Timer Mode (GPTMTnMR)** register, write the $TnCMR$ field to 0x1 and the $TnMR$ field to 0x3.
4. Configure the type of event that the timer captures by writing the $TnEVENT$ field of the **GPTM Control (GPTMCTL)** register.
5. If a prescaler is to be used, write the prescale value to the **GPTM Timer n Prescale Register (GPTMTnPR)**.
6. Load the timer start value into the **GPTM Timer n Interval Load (GPTMTnILR)** register.
7. If interrupts are required, set the $CnEIM$ bit in the **GPTM Interrupt Mask (GPTMIMR)** register.
8. Set the $TnEN$ bit in the **GPTM Control (GPTMCTL)** register to enable the timer and start counting.
9. Poll the $CnERIS$ bit in the **GPTMRIS** register or wait for the interrupt to be generated (if enabled). In both cases, the status flags are cleared by writing a 1 to the $CnECINT$ bit of the **GPTM Interrupt Clear (GPTMICR)** register. The time at which the event happened can be obtained by reading the **GPTM Timer n (GPTMTnR)** register.

In Input Edge Timing mode, the timer continues running after an edge event has been detected, but the timer interval can be changed at any time by writing the **GPTMTnILR** register. The change takes effect at the next cycle after the write.

10.4.5 PWM Mode

A timer is configured to PWM mode using the following sequence:

1. Ensure the timer is disabled (the $TnEN$ bit is cleared) before making any changes.
2. Write the **GPTM Configuration (GPTMCFG)** register with a value of 0x0000.0004.
3. In the **GPTM Timer Mode (GPTMTnMR)** register, set the $TnAMS$ bit to 0x1, the $TnCMR$ bit to 0x0, and the $TnMR$ field to 0x2.

4. Configure the output state of the PWM signal (whether or not it is inverted) in the T_nPWML field of the **GPTM Control (GPTMCTL)** register.
5. If a prescaler is to be used, write the prescale value to the **GPTM Timer n Prescale Register (GPTMTnPR)**.
6. If PWM interrupts are used, configure the interrupt condition in the T_nEVENT field in the **GPTMCTL** register and enable the interrupts by setting the T_nPWMIE bit in the **GPTMTnMR** register. Note that edge detect interrupt behavior is reversed when the PWM output is inverted (see page 710).
7. Load the timer start value into the **GPTM Timer n Interval Load (GPTMTnILR)** register.
8. Load the **GPTM Timer n Match (GPTMTnMATCHR)** register with the match value.
9. Set the T_nEN bit in the **GPTM Control (GPTMCTL)** register to enable the timer and begin generation of the output PWM signal.

In PWM Timing mode, the timer continues running after the PWM signal has been generated. The PWM period can be adjusted at any time by writing the **GPTMTnILR** register, and the change takes effect at the next cycle after the write.

10.5 Register Map

Table 10-12 on page 698 lists the GPTM registers. The offset listed is a hexadecimal increment to the register's address, relative to that timer's base address:

- 16/32-bit Timer 0: 0x4003.0000
- 16/32-bit Timer 1: 0x4003.1000
- 16/32-bit Timer 2: 0x4003.2000
- 16/32-bit Timer 3: 0x4003.3000
- 16/32-bit Timer 4: 0x4003.4000
- 16/32-bit Timer 5: 0x4003.5000
- 32/64-bit Wide Timer 0: 0x4003.6000
- 32/64-bit Wide Timer 1: 0x4003.7000
- 32/64-bit Wide Timer 2: 0x4004.C000
- 32/64-bit Wide Timer 3: 0x4004.D000
- 32/64-bit Wide Timer 4: 0x4004.E000
- 32/64-bit Wide Timer 5: 0x4004.F000

The $SIZE$ field in the **GPTM Peripheral Properties (GPTMPP)** register identifies whether a module has a 16/32-bit or 32/64-bit wide timer.

Note that the GP Timer module clock must be enabled before the registers can be programmed (see page 317 or page 335). There must be a delay of 3 system clocks after the Timer module clock is enabled before any Timer module registers are accessed.

Table 10-12. Timers Register Map

Offset	Name	Type	Reset	Description	See page
0x000	GPTMCFG	R/W	0x0000.0000	GPTM Configuration	700
0x004	GPTMTAMR	R/W	0x0000.0000	GPTM Timer A Mode	702

Table 10-12. Timers Register Map (continued)

Offset	Name	Type	Reset	Description	See page
0x008	GPTMTBMR	R/W	0x0000.0000	GPTM Timer B Mode	706
0x00C	GPTMCTL	R/W	0x0000.0000	GPTM Control	710
0x010	GPTMSYNC	R/W	0x0000.0000	GPTM Synchronize	714
0x018	GPTMIMR	R/W	0x0000.0000	GPTM Interrupt Mask	718
0x01C	GPTMRIS	RO	0x0000.0000	GPTM Raw Interrupt Status	721
0x020	GPTMMIS	RO	0x0000.0000	GPTM Masked Interrupt Status	724
0x024	GPTMICR	W1C	0x0000.0000	GPTM Interrupt Clear	727
0x028	GPTMTAILR	R/W	0xFFFF.FFFF	GPTM Timer A Interval Load	729
0x02C	GPTMTBILR	R/W	-	GPTM Timer B Interval Load	730
0x030	GPTMTAMATCHR	R/W	0xFFFF.FFFF	GPTM Timer A Match	731
0x034	GPTMTBMATCHR	R/W	-	GPTM Timer B Match	732
0x038	GPTMTAPR	R/W	0x0000.0000	GPTM Timer A Prescale	733
0x03C	GPTMTBPR	R/W	0x0000.0000	GPTM Timer B Prescale	734
0x040	GPTMTAPMR	R/W	0x0000.0000	GPTM TimerA Prescale Match	735
0x044	GPTMTBPMR	R/W	0x0000.0000	GPTM TimerB Prescale Match	736
0x048	GPTMTAR	RO	0xFFFF.FFFF	GPTM Timer A	737
0x04C	GPTMTBR	RO	-	GPTM Timer B	738
0x050	GPTMTAV	RW	0xFFFF.FFFF	GPTM Timer A Value	739
0x054	GPTMTBV	RW	-	GPTM Timer B Value	740
0x058	GPTMRTCPD	RO	0x0000.7FFF	GPTM RTC Predivide	741
0x05C	GPTMTAPS	RO	0x0000.0000	GPTM Timer A Prescale Snapshot	742
0x060	GPTMTBPS	RO	0x0000.0000	GPTM Timer B Prescale Snapshot	743
0x064	GPTMTAPV	RO	0x0000.0000	GPTM Timer A Prescale Value	744
0x068	GPTMTBPV	RO	0x0000.0000	GPTM Timer B Prescale Value	745
0xFC0	GPTMPP	RO	0x0000.0000	GPTM Peripheral Properties	746

10.6 Register Descriptions

The remainder of this section lists and describes the GPTM registers, in numerical order by address offset.

Register 1: GPTM Configuration (GPTMCFG), offset 0x000

This register configures the global operation of the GPTM module. The value written to this register determines whether the GPTM is in 32- or 64-bit mode (concatenated timers) or in 16- or 32-bit mode (individual, split timers).

Important: Bits in this register should only be changed when the TAEN and TBEN bits in the GPTMCTL register are cleared.

GPTM Configuration (GPTMCFG)

16/32-bit Timer 0 base: 0x4003.0000
 16/32-bit Timer 1 base: 0x4003.1000
 16/32-bit Timer 2 base: 0x4003.2000
 16/32-bit Timer 3 base: 0x4003.3000
 16/32-bit Timer 4 base: 0x4003.4000
 16/32-bit Timer 5 base: 0x4003.5000
 32/64-bit Wide Timer 0 base: 0x4003.6000
 32/64-bit Wide Timer 1 base: 0x4003.7000
 32/64-bit Wide Timer 2 base: 0x4004.C000
 32/64-bit Wide Timer 3 base: 0x4004.D000
 32/64-bit Wide Timer 4 base: 0x4004.E000
 32/64-bit Wide Timer 5 base: 0x4004.F000
 Offset 0x000
 Type R/W, reset 0x0000.0000

	31	30	29	28	27	26	25	24	23	22	21	20	19	18	17	16
	reserved															
Type	RO	RO	RO	RO	RO	RO	RO	RO	RO	RO	RO	RO	RO	RO	RO	RO
Reset	0	0	0	0	0	0	0	0	0	0	0	0	0	0	0	0
	15	14	13	12	11	10	9	8	7	6	5	4	3	2	1	0
	reserved													GPTMCFG		
Type	RO	RO	RO	RO	RO	RO	RO	RO	RO	RO	RO	RO	RO	R/W	R/W	R/W
Reset	0	0	0	0	0	0	0	0	0	0	0	0	0	0	0	0

Bit/Field	Name	Type	Reset	Description
31:3	reserved	RO	0x0000.000	Software should not rely on the value of a reserved bit. To provide compatibility with future products, the value of a reserved bit should be preserved across a read-modify-write operation.

Bit/Field	Name	Type	Reset	Description												
2:0	GPTMCFG	R/W	0x0	<p>GPTM Configuration</p> <p>The GPTMCFG values are defined as follows:</p> <table border="1"> <thead> <tr> <th>Value</th> <th>Description</th> </tr> </thead> <tbody> <tr> <td>0x0</td> <td> <p>For a 16/32-bit timer, this value selects the 32-bit timer configuration.</p> <p>For a 32/64-bit wide timer, this value selects the 64-bit timer configuration.</p> </td> </tr> <tr> <td>0x1</td> <td> <p>For a 16/32-bit timer, this value selects the 32-bit real-time clock (RTC) counter configuration.</p> <p>For a 32/64-bit wide timer, this value selects the 64-bit real-time clock (RTC) counter configuration.</p> </td> </tr> <tr> <td>0x2-0x3</td> <td>Reserved</td> </tr> <tr> <td>0x4</td> <td> <p>For a 16/32-bit timer, this value selects the 16-bit timer configuration.</p> <p>For a 32/64-bit wide timer, this value selects the 32-bit timer configuration.</p> <p>The function is controlled by bits 1:0 of GPTMTAMR and GPTMTBMR.</p> </td> </tr> <tr> <td>0x5-0x7</td> <td>Reserved</td> </tr> </tbody> </table>	Value	Description	0x0	<p>For a 16/32-bit timer, this value selects the 32-bit timer configuration.</p> <p>For a 32/64-bit wide timer, this value selects the 64-bit timer configuration.</p>	0x1	<p>For a 16/32-bit timer, this value selects the 32-bit real-time clock (RTC) counter configuration.</p> <p>For a 32/64-bit wide timer, this value selects the 64-bit real-time clock (RTC) counter configuration.</p>	0x2-0x3	Reserved	0x4	<p>For a 16/32-bit timer, this value selects the 16-bit timer configuration.</p> <p>For a 32/64-bit wide timer, this value selects the 32-bit timer configuration.</p> <p>The function is controlled by bits 1:0 of GPTMTAMR and GPTMTBMR.</p>	0x5-0x7	Reserved
Value	Description															
0x0	<p>For a 16/32-bit timer, this value selects the 32-bit timer configuration.</p> <p>For a 32/64-bit wide timer, this value selects the 64-bit timer configuration.</p>															
0x1	<p>For a 16/32-bit timer, this value selects the 32-bit real-time clock (RTC) counter configuration.</p> <p>For a 32/64-bit wide timer, this value selects the 64-bit real-time clock (RTC) counter configuration.</p>															
0x2-0x3	Reserved															
0x4	<p>For a 16/32-bit timer, this value selects the 16-bit timer configuration.</p> <p>For a 32/64-bit wide timer, this value selects the 32-bit timer configuration.</p> <p>The function is controlled by bits 1:0 of GPTMTAMR and GPTMTBMR.</p>															
0x5-0x7	Reserved															

Register 2: GPTM Timer A Mode (GPTMTAMR), offset 0x004

This register configures the GPTM based on the configuration selected in the **GPTMCFG** register. When in PWM mode, set the **TAAMS** bit, clear the **TACMR** bit, and configure the **TAMR** field to 0x1 or 0x2.

This register controls the modes for Timer A when it is used individually. When Timer A and Timer B are concatenated, this register controls the modes for both Timer A and Timer B, and the contents of **GPTMTBMR** are ignored.

Important: Except for the **TCACT** bit field, all other bits in this register should only be changed when the **TAEN** bit in the **GPTMCTL** register is cleared.

GPTM Timer A Mode (GPTMTAMR)

16/32-bit Timer 0 base: 0x4003.0000
 16/32-bit Timer 1 base: 0x4003.1000
 16/32-bit Timer 2 base: 0x4003.2000
 16/32-bit Timer 3 base: 0x4003.3000
 16/32-bit Timer 4 base: 0x4003.4000
 16/32-bit Timer 5 base: 0x4003.5000
 32/64-bit Wide Timer 0 base: 0x4003.6000
 32/64-bit Wide Timer 1 base: 0x4003.7000
 32/64-bit Wide Timer 2 base: 0x4004.C000
 32/64-bit Wide Timer 3 base: 0x4004.D000
 32/64-bit Wide Timer 4 base: 0x4004.E000
 32/64-bit Wide Timer 5 base: 0x4004.F000
 Offset 0x004
 Type R/W, reset 0x0000.0000

	31	30	29	28	27	26	25	24	23	22	21	20	19	18	17	16
	reserved															
Type	RO	RO	RO	RO	RO	RO	RO	RO	RO	RO	RO	RO	RO	RO	RO	RO
Reset	0	0	0	0	0	0	0	0	0	0	0	0	0	0	0	0
	15	14	13	12	11	10	9	8	7	6	5	4	3	2	1	0
	reserved				TAPLO	TAMRSU	TAPWMIE	TAILD	TASNAPS	TAWOT	TAMIE	TACDIR	TAAMS	TACMR	TAMR	
Type	RO	RO	RO	RO	R/W	R/W	R/W	R/W	R/W	R/W	R/W	R/W	R/W	R/W	R/W	R/W
Reset	0	0	0	0	0	0	0	0	0	0	0	0	0	0	0	0

Bit/Field	Name	Type	Reset	Description
31:12	reserved	RO	0x0000.00	Software should not rely on the value of a reserved bit. To provide compatibility with future products, the value of a reserved bit should be preserved across a read-modify-write operation.

11 TAPLO R/W 0 GPTM Timer A PWM Legacy Operation

Value	Description
0	Legacy operation with CCP pin driven Low when the GPTMTAILR is reloaded after the timer reaches 0.
1	CCP is driven High when the GPTMTAILR is reloaded after the timer reaches 0.

This bit is only valid in PWM mode.

Bit/Field	Name	Type	Reset	Description
10	TAMRSU	R/W	0	<p>GPTM Timer A Match Register Update</p> <p>Value Description</p> <p>0 Update the GPTMTAMATCHR register and the GPTMTAPR register, if used, on the next cycle.</p> <p>1 Update the GPTMTAMATCHR register and the GPTMTAPR register, if used, on the next timeout.</p> <p>If the timer is disabled (TAEN is clear) when this bit is set, GPTMTAMATCHR and GPTMTAPR are updated when the timer is enabled. If the timer is stalled (TASTALL is set), GPTMTAMATCHR and GPTMTAPR are updated according to the configuration of this bit.</p>
9	TAPWMIE	R/W	0	<p>GPTM Timer A PWM Interrupt Enable</p> <p>This bit enables interrupts in PWM mode on rising, falling, or both edges of the CCP output, as defined by the TAEVENT field in the GPTMCTL register.</p> <p>Value Description</p> <p>0 Interrupt is disabled.</p> <p>1 Interrupt is enabled.</p> <p>This bit is only valid in PWM mode.</p>
8	TAILD	R/W	0	<p>GPTM Timer A Interval Load Write</p> <p>Value Description</p> <p>0 Update the GPTMTAR and GPTMTAV registers with the value in the GPTMTAILR register on the next cycle. Also update the GPTMTAPS and GPTMTAPV registers with the value in the GPTMTAPR register on the next cycle.</p> <p>1 Update the GPTMTAR and GPTMTAV registers with the value in the GPTMTAILR and GPTMTAPV registers on the next timeout. Also update the GPTMTAPS register with the value in the GPTMTAPR register on the next timeout.</p> <p>Note the state of this bit has no effect when counting up.</p> <p>The bit descriptions above apply if the timer is enabled and running. If the timer is disabled (TAEN is clear) when this bit is set, GPTMTAR, GPTMTAV, GPTMTAPS, and GPTMTAPV are updated when the timer is enabled. If the timer is stalled (TASTALL is set), GPTMTAR and GPTMTAPS are updated according to the configuration of this bit.</p>
7	TASNAPS	R/W	0	<p>GPTM Timer A Snap-Shot Mode</p> <p>Value Description</p> <p>0 Snap-shot mode is disabled.</p> <p>1 If Timer A is configured in the periodic mode, the actual free-running value of Timer A is loaded at the time-out event into the GPTM Timer A (GPTMTAR) register. If the timer prescaler is used, the prescaler snapshot is loaded into the GPTM Timer A (GPTMTAPR).</p>

Bit/Field	Name	Type	Reset	Description
6	TAWOT	R/W	0	<p>GPTM Timer A Wait-on-Trigger</p> <p>Value Description</p> <p>0 Timer A begins counting as soon as it is enabled.</p> <p>1 If Timer A is enabled (<i>TAEN</i> is set in the GPTMCTL register), Timer A does not begin counting until it receives a trigger from the timer in the previous position in the daisy chain, see Figure 10-9 on page 692. This function is valid for one-shot, periodic, and PWM modes.</p> <p>This bit must be clear for GP Timer Module 0, Timer A.</p>
5	TAMIE	R/W	0	<p>GPTM Timer A Match Interrupt Enable</p> <p>Value Description</p> <p>0 The match interrupt is disabled.</p> <p>1 An interrupt is generated when the match value in the GPTMTAMATCHR register is reached in the one-shot and periodic modes.</p>
4	TACDIR	R/W	0	<p>GPTM Timer A Count Direction</p> <p>Value Description</p> <p>0 The timer counts down.</p> <p>1 The timer counts up. When counting up, the timer starts from a value of 0x0.</p> <p>When in PWM or RTC mode, the status of this bit is ignored. PWM mode always counts down and RTC mode always counts up.</p>
3	TAAMS	R/W	0	<p>GPTM Timer A Alternate Mode Select</p> <p>The <i>TAAMS</i> values are defined as follows:</p> <p>Value Description</p> <p>0 Capture mode is enabled.</p> <p>1 PWM mode is enabled.</p> <p>Note: To enable PWM mode, you must also clear the <i>TACMR</i> bit and configure the <i>TAMR</i> field to 0x1 or 0x2.</p>
2	TACMR	R/W	0	<p>GPTM Timer A Capture Mode</p> <p>The <i>TACMR</i> values are defined as follows:</p> <p>Value Description</p> <p>0 Edge-Count mode</p> <p>1 Edge-Time mode</p>

Bit/Field	Name	Type	Reset	Description
1:0	TAMR	R/W	0x0	GPTM Timer A Mode The TAMR values are defined as follows: Value Description 0x0 Reserved 0x1 One-Shot Timer mode 0x2 Periodic Timer mode 0x3 Capture mode The Timer mode is based on the timer configuration defined by bits 2:0 in the GPTMCFG register.

Register 3: GPTM Timer B Mode (GPTMTBMR), offset 0x008

This register configures the GPTM based on the configuration selected in the **GPTMCFG** register. When in PWM mode, set the **TBAMS** bit, clear the **TBCMR** bit, and configure the **TBMR** field to 0x1 or 0x2.

This register controls the modes for Timer B when it is used individually. When Timer A and Timer B are concatenated, this register is ignored and **GPTMTBMR** controls the modes for both Timer A and Timer B.

Important: Except for the **TCACT** bit field, all other bits in this register should only be changed when the **TBEN** bit in the **GPTMCTL** register is cleared.

GPTM Timer B Mode (GPTMTBMR)

16/32-bit Timer 0 base: 0x4003.0000
 16/32-bit Timer 1 base: 0x4003.1000
 16/32-bit Timer 2 base: 0x4003.2000
 16/32-bit Timer 3 base: 0x4003.3000
 16/32-bit Timer 4 base: 0x4003.4000
 16/32-bit Timer 5 base: 0x4003.5000
 32/64-bit Wide Timer 0 base: 0x4003.6000
 32/64-bit Wide Timer 1 base: 0x4003.7000
 32/64-bit Wide Timer 2 base: 0x4004.C000
 32/64-bit Wide Timer 3 base: 0x4004.D000
 32/64-bit Wide Timer 4 base: 0x4004.E000
 32/64-bit Wide Timer 5 base: 0x4004.F000
 Offset 0x008
 Type R/W, reset 0x0000.0000

	31	30	29	28	27	26	25	24	23	22	21	20	19	18	17	16
	reserved															
Type	RO	RO	RO	RO	RO	RO	RO	RO	RO	RO	RO	RO	RO	RO	RO	RO
Reset	0	0	0	0	0	0	0	0	0	0	0	0	0	0	0	0
	15	14	13	12	11	10	9	8	7	6	5	4	3	2	1	0
	reserved				TBPLO	TBMRSU	TBPWMIE	TBILD	TBSNAPS	TBWOT	TBMIE	TBCDIR	TBAMS	TBCMR	TBMR	
Type	RO	RO	RO	RO	R/W	R/W	R/W	R/W	R/W	R/W	R/W	R/W	R/W	R/W	R/W	R/W
Reset	0	0	0	0	0	0	0	0	0	0	0	0	0	0	0	0

Bit/Field	Name	Type	Reset	Description
31:12	reserved	RO	0x0000.00	Software should not rely on the value of a reserved bit. To provide compatibility with future products, the value of a reserved bit should be preserved across a read-modify-write operation.

11 TBPLO R/W 0 GPTM Timer B PWM Legacy Operation

Value	Description
0	Legacy operation with CCP pin driven Low when the GPTMTAILR is reloaded after the timer reaches 0.
1	CCP is driven High when the GPTMTAILR is reloaded after the timer reaches 0.

This bit is only valid in PWM mode.

Bit/Field	Name	Type	Reset	Description
10	TBMRSU	R/W	0	<p>GPTM Timer B Match Register Update</p> <p>Value Description</p> <p>0 Update the GPTMTBMATCHR register and the GPTMTBPR register, if used, on the next cycle.</p> <p>1 Update the GPTMTBMATCHR register and the GPTMTBPR register, if used, on the next timeout.</p> <p>If the timer is disabled (TBEN is clear) when this bit is set, GPTMTBMATCHR and GPTMTBPR are updated when the timer is enabled. If the timer is stalled (TBSTALL is set), GPTMTBMATCHR and GPTMTBPR are updated according to the configuration of this bit.</p>
9	TBPWMIE	R/W	0	<p>GPTM Timer B PWM Interrupt Enable</p> <p>This bit enables interrupts in PWM mode on rising, falling, or both edges of the CCP output as defined by the TBEVENT field in the GPTMCTL register.</p> <p>Value Description</p> <p>0 Interrupt is disabled.</p> <p>1 Interrupt is enabled.</p> <p>This bit is only valid in PWM mode.</p>
8	TBILD	R/W	0	<p>GPTM Timer B Interval Load Write</p> <p>Value Description</p> <p>0 Update the GPTMTBR and GPTMTBV registers with the value in the GPTMTBILR register on the next cycle. Also update the GPTMTBPS and GPTMTBPV registers with the value in the GPTMTBPR register on the next cycle.</p> <p>1 Update the GPTMTBR and GPTMTBV registers with the value in the GPTMTBILR register on the next timeout. Also update the GPTMTBPS and GPTMTBPV registers with the value in the GPTMTBPR register on the next timeout.</p> <p>Note the state of this bit has no effect when counting up.</p> <p>The bit descriptions above apply if the timer is enabled and running. If the timer is disabled (TBEN is clear) when this bit is set, GPTMTBR, GPTMTBV, GPTMTBPS, and GPTMTBPV are updated when the timer is enabled. If the timer is stalled (TBSTALL is set), GPTMTBR and GPTMTBPS are updated according to the configuration of this bit.</p>
7	TBSNAPS	R/W	0	<p>GPTM Timer B Snap-Shot Mode</p> <p>Value Description</p> <p>0 Snap-shot mode is disabled.</p> <p>1 If Timer B is configured in the periodic mode, the actual free-running value of Timer B is loaded at the time-out event into the GPTM Timer B (GPTMTBR) register. If the timer prescaler is used, the prescaler snapshot is loaded into the GPTM Timer B (GPTMTBPR).</p>

Bit/Field	Name	Type	Reset	Description
6	TBWOT	R/W	0	<p>GPTM Timer B Wait-on-Trigger</p> <p>Value Description</p> <p>0 Timer B begins counting as soon as it is enabled.</p> <p>1 If Timer B is enabled (TBEN is set in the GPTMCTL register), Timer B does not begin counting until it receives an it receives a trigger from the timer in the previous position in the daisy chain, see Figure 10-9 on page 692. This function is valid for one-shot, periodic, and PWM modes.</p>
5	TBMIE	R/W	0	<p>GPTM Timer B Match Interrupt Enable</p> <p>Value Description</p> <p>0 The match interrupt is disabled.</p> <p>1 An interrupt is generated when the match value in the GPTMTBMATCHR register is reached in the one-shot and periodic modes.</p>
4	TBCDIR	R/W	0	<p>GPTM Timer B Count Direction</p> <p>Value Description</p> <p>0 The timer counts down.</p> <p>1 The timer counts up. When counting up, the timer starts from a value of 0x0.</p> <p>When in PWM or RTC mode, the status of this bit is ignored. PWM mode always counts down and RTC mode always counts up.</p>
3	TBAMS	R/W	0	<p>GPTM Timer B Alternate Mode Select</p> <p>The TBAMS values are defined as follows:</p> <p>Value Description</p> <p>0 Capture mode is enabled.</p> <p>1 PWM mode is enabled.</p> <p>Note: To enable PWM mode, you must also clear the TBCMR bit and configure the TBMR field to 0x1 or 0x2.</p>
2	TBCMR	R/W	0	<p>GPTM Timer B Capture Mode</p> <p>The TBCMR values are defined as follows:</p> <p>Value Description</p> <p>0 Edge-Count mode</p> <p>1 Edge-Time mode</p>

Bit/Field	Name	Type	Reset	Description
1:0	TBMR	R/W	0x0	GPTM Timer B Mode The TBMR values are defined as follows: Value Description 0x0 Reserved 0x1 One-Shot Timer mode 0x2 Periodic Timer mode 0x3 Capture mode The timer mode is based on the timer configuration defined by bits 2:0 in the GPTMCFG register.

Register 4: GPTM Control (GPTMCTL), offset 0x00C

This register is used alongside the **GPTMCFG** and **GMTMTnMR** registers to fine-tune the timer configuration, and to enable other features such as timer stall and the output trigger. The output trigger can be used to initiate transfers on the ADC module.

Important: Bits in this register should only be changed when the **TnEN** bit for the respective timer is cleared.

GPTM Control (GPTMCTL)

16/32-bit Timer 0 base: 0x4003.0000
 16/32-bit Timer 1 base: 0x4003.1000
 16/32-bit Timer 2 base: 0x4003.2000
 16/32-bit Timer 3 base: 0x4003.3000
 16/32-bit Timer 4 base: 0x4003.4000
 16/32-bit Timer 5 base: 0x4003.5000
 32/64-bit Wide Timer 0 base: 0x4003.6000
 32/64-bit Wide Timer 1 base: 0x4003.7000
 32/64-bit Wide Timer 2 base: 0x4004.C000
 32/64-bit Wide Timer 3 base: 0x4004.D000
 32/64-bit Wide Timer 4 base: 0x4004.E000
 32/64-bit Wide Timer 5 base: 0x4004.F000
 Offset 0x00C
 Type R/W, reset 0x0000.0000

	31	30	29	28	27	26	25	24	23	22	21	20	19	18	17	16
	reserved															
Type	RO	RO	RO	RO	RO	RO	RO	RO	RO	RO	RO	RO	RO	RO	RO	RO
Reset	0	0	0	0	0	0	0	0	0	0	0	0	0	0	0	0
	15	14	13	12	11	10	9	8	7	6	5	4	3	2	1	0
	reserved	TBPWML	TBOTE	reserved	TBEVENT	TBSTALL	TBEN	reserved	TAPWML	TAOTE	RTCEN	TAEVENT	TASTALL	TAEN		
Type	RO	R/W	R/W	RO	R/W	R/W	R/W	R/W	RO	R/W	R/W	R/W	R/W	R/W	R/W	R/W
Reset	0	0	0	0	0	0	0	0	0	0	0	0	0	0	0	0

Bit/Field	Name	Type	Reset	Description						
31:15	reserved	RO	0x0000	Software should not rely on the value of a reserved bit. To provide compatibility with future products, the value of a reserved bit should be preserved across a read-modify-write operation.						
14	TBPWML	R/W	0	GPTM Timer B PWM Output Level The TBPWML values are defined as follows: <table border="0"> <tr> <td>Value</td> <td>Description</td> </tr> <tr> <td>0</td> <td>Output is unaffected.</td> </tr> <tr> <td>1</td> <td>Output is inverted.</td> </tr> </table>	Value	Description	0	Output is unaffected.	1	Output is inverted.
Value	Description									
0	Output is unaffected.									
1	Output is inverted.									
13	TBOTE	R/W	0	GPTM Timer B Output Trigger Enable The TBOTE values are defined as follows: <table border="0"> <tr> <td>Value</td> <td>Description</td> </tr> <tr> <td>0</td> <td>The output Timer B ADC trigger is disabled.</td> </tr> <tr> <td>1</td> <td>The output Timer B ADC trigger is enabled.</td> </tr> </table> <p>In addition, the ADC must be enabled and the timer selected as a trigger source with the EMn bit in the ADCEMUX register (see page 803).</p>	Value	Description	0	The output Timer B ADC trigger is disabled.	1	The output Timer B ADC trigger is enabled.
Value	Description									
0	The output Timer B ADC trigger is disabled.									
1	The output Timer B ADC trigger is enabled.									

Bit/Field	Name	Type	Reset	Description										
12	reserved	RO	0	Software should not rely on the value of a reserved bit. To provide compatibility with future products, the value of a reserved bit should be preserved across a read-modify-write operation.										
11:10	TBEVENT	R/W	0x0	<p>GPTM Timer B Event Mode</p> <p>The TBEVENT values are defined as follows:</p> <table border="1"> <thead> <tr> <th>Value</th> <th>Description</th> </tr> </thead> <tbody> <tr> <td>0x0</td> <td>Positive edge</td> </tr> <tr> <td>0x1</td> <td>Negative edge</td> </tr> <tr> <td>0x2</td> <td>Reserved</td> </tr> <tr> <td>0x3</td> <td>Both edges</td> </tr> </tbody> </table> <p>Note: If PWM output inversion is enabled, edge detection interrupt behavior is reversed. Thus, if a positive-edge interrupt trigger has been set and the PWM inversion generates a positive edge, no event-trigger interrupt asserts. Instead, the interrupt is generated on the negative edge of the PWM signal.</p>	Value	Description	0x0	Positive edge	0x1	Negative edge	0x2	Reserved	0x3	Both edges
Value	Description													
0x0	Positive edge													
0x1	Negative edge													
0x2	Reserved													
0x3	Both edges													
9	TBSTALL	R/W	0	<p>GPTM Timer B Stall Enable</p> <p>The TBSTALL values are defined as follows:</p> <table border="1"> <thead> <tr> <th>Value</th> <th>Description</th> </tr> </thead> <tbody> <tr> <td>0</td> <td>Timer B continues counting while the processor is halted by the debugger.</td> </tr> <tr> <td>1</td> <td>Timer B freezes counting while the processor is halted by the debugger.</td> </tr> </tbody> </table> <p>If the processor is executing normally, the TBSTALL bit is ignored.</p>	Value	Description	0	Timer B continues counting while the processor is halted by the debugger.	1	Timer B freezes counting while the processor is halted by the debugger.				
Value	Description													
0	Timer B continues counting while the processor is halted by the debugger.													
1	Timer B freezes counting while the processor is halted by the debugger.													
8	TBEN	R/W	0	<p>GPTM Timer B Enable</p> <p>The TBEN values are defined as follows:</p> <table border="1"> <thead> <tr> <th>Value</th> <th>Description</th> </tr> </thead> <tbody> <tr> <td>0</td> <td>Timer B is disabled.</td> </tr> <tr> <td>1</td> <td>Timer B is enabled and begins counting or the capture logic is enabled based on the GPTMCFG register.</td> </tr> </tbody> </table>	Value	Description	0	Timer B is disabled.	1	Timer B is enabled and begins counting or the capture logic is enabled based on the GPTMCFG register.				
Value	Description													
0	Timer B is disabled.													
1	Timer B is enabled and begins counting or the capture logic is enabled based on the GPTMCFG register.													
7	reserved	RO	0	Software should not rely on the value of a reserved bit. To provide compatibility with future products, the value of a reserved bit should be preserved across a read-modify-write operation.										
6	TAPWML	R/W	0	<p>GPTM Timer A PWM Output Level</p> <p>The TAPWML values are defined as follows:</p> <table border="1"> <thead> <tr> <th>Value</th> <th>Description</th> </tr> </thead> <tbody> <tr> <td>0</td> <td>Output is unaffected.</td> </tr> <tr> <td>1</td> <td>Output is inverted.</td> </tr> </tbody> </table>	Value	Description	0	Output is unaffected.	1	Output is inverted.				
Value	Description													
0	Output is unaffected.													
1	Output is inverted.													

Bit/Field	Name	Type	Reset	Description										
5	TAOTE	R/W	0	<p>GPTM Timer A Output Trigger Enable</p> <p>The TAOTE values are defined as follows:</p> <table border="1"> <thead> <tr> <th>Value</th> <th>Description</th> </tr> </thead> <tbody> <tr> <td>0</td> <td>The output Timer A ADC trigger is disabled.</td> </tr> <tr> <td>1</td> <td>The output Timer A ADC trigger is enabled.</td> </tr> </tbody> </table> <p>In addition, the ADC must be enabled and the timer selected as a trigger source with the EM_n bit in the ADCEMUX register (see page 803).</p>	Value	Description	0	The output Timer A ADC trigger is disabled.	1	The output Timer A ADC trigger is enabled.				
Value	Description													
0	The output Timer A ADC trigger is disabled.													
1	The output Timer A ADC trigger is enabled.													
4	RTCEN	R/W	0	<p>GPTM RTC Stall Enable</p> <p>The RTCEN values are defined as follows:</p> <table border="1"> <thead> <tr> <th>Value</th> <th>Description</th> </tr> </thead> <tbody> <tr> <td>0</td> <td>RTC counting freezes while the processor is halted by the debugger.</td> </tr> <tr> <td>1</td> <td>RTC counting continues while the processor is halted by the debugger.</td> </tr> </tbody> </table> <p>If the RTCEN bit is set, it prevents the timer from stalling in all operating modes, even if TnSTALL is set.</p>	Value	Description	0	RTC counting freezes while the processor is halted by the debugger.	1	RTC counting continues while the processor is halted by the debugger.				
Value	Description													
0	RTC counting freezes while the processor is halted by the debugger.													
1	RTC counting continues while the processor is halted by the debugger.													
3:2	TAEVENT	R/W	0x0	<p>GPTM Timer A Event Mode</p> <p>The TAEVENT values are defined as follows:</p> <table border="1"> <thead> <tr> <th>Value</th> <th>Description</th> </tr> </thead> <tbody> <tr> <td>0x0</td> <td>Positive edge</td> </tr> <tr> <td>0x1</td> <td>Negative edge</td> </tr> <tr> <td>0x2</td> <td>Reserved</td> </tr> <tr> <td>0x3</td> <td>Both edges</td> </tr> </tbody> </table> <p>Note: If PWM output inversion is enabled, edge detection interrupt behavior is reversed. Thus, if a positive-edge interrupt trigger has been set and the PWM inversion generates a positive edge, no event-trigger interrupt asserts. Instead, the interrupt is generated on the negative edge of the PWM signal.</p>	Value	Description	0x0	Positive edge	0x1	Negative edge	0x2	Reserved	0x3	Both edges
Value	Description													
0x0	Positive edge													
0x1	Negative edge													
0x2	Reserved													
0x3	Both edges													
1	TASTALL	R/W	0	<p>GPTM Timer A Stall Enable</p> <p>The TASTALL values are defined as follows:</p> <table border="1"> <thead> <tr> <th>Value</th> <th>Description</th> </tr> </thead> <tbody> <tr> <td>0</td> <td>Timer A continues counting while the processor is halted by the debugger.</td> </tr> <tr> <td>1</td> <td>Timer A freezes counting while the processor is halted by the debugger.</td> </tr> </tbody> </table> <p>If the processor is executing normally, the TASTALL bit is ignored.</p>	Value	Description	0	Timer A continues counting while the processor is halted by the debugger.	1	Timer A freezes counting while the processor is halted by the debugger.				
Value	Description													
0	Timer A continues counting while the processor is halted by the debugger.													
1	Timer A freezes counting while the processor is halted by the debugger.													

Bit/Field	Name	Type	Reset	Description
0	TAEN	R/W	0	GPTM Timer A Enable The TAEN values are defined as follows: Value Description 0 Timer A is disabled. 1 Timer A is enabled and begins counting or the capture logic is enabled based on the GPTMCFG register.

Register 5: GPTM Synchronize (GPTMSYNC), offset 0x010

Note: This register is only implemented on GPTM Module 0 only.

This register allows software to synchronize a number of timers.

GPTM Synchronize (GPTMSYNC)

16/32-bit Timer 0 base: 0x4003.0000
 16/32-bit Timer 1 base: 0x4003.1000
 16/32-bit Timer 2 base: 0x4003.2000
 16/32-bit Timer 3 base: 0x4003.3000
 16/32-bit Timer 4 base: 0x4003.4000
 16/32-bit Timer 5 base: 0x4003.5000
 32/64-bit Wide Timer 0 base: 0x4003.6000
 32/64-bit Wide Timer 1 base: 0x4003.7000
 32/64-bit Wide Timer 2 base: 0x4004.C000
 32/64-bit Wide Timer 3 base: 0x4004.D000
 32/64-bit Wide Timer 4 base: 0x4004.E000
 32/64-bit Wide Timer 5 base: 0x4004.F000
 Offset 0x010
 Type R/W, reset 0x0000.0000

	31	30	29	28	27	26	25	24	23	22	21	20	19	18	17	16
	reserved								SYNCWT5		SYNCWT4		SYNCWT3		SYNCWT2	
Type	RO	RO	RO	RO	RO	RO	RO	RO	R/W	R/W	R/W	R/W	R/W	R/W	R/W	R/W
Reset	0	0	0	0	0	0	0	0	0	0	0	0	0	0	0	0
	15	14	13	12	11	10	9	8	7	6	5	4	3	2	1	0
	SYNCWT1		SYNCWT0		SYNCT5		SYNCT4		SYNCT3		SYNCT2		SYNCT1		SYNCT0	
Type	R/W	R/W	R/W	R/W	R/W	R/W	R/W	R/W	R/W	R/W	R/W	R/W	R/W	R/W	R/W	R/W
Reset	0	0	0	0	0	0	0	0	0	0	0	0	0	0	0	0

Bit/Field	Name	Type	Reset	Description
31:24	reserved	RO	0x00	Software should not rely on the value of a reserved bit. To provide compatibility with future products, the value of a reserved bit should be preserved across a read-modify-write operation.
23:22	SYNCWT5	R/W	0x0	Synchronize GPTM 32/64-Bit Timer 5 The SYNCWT5 values are defined as follows: Value Description 0x0 GPTM 32/64-Bit Timer 5 is not affected. 0x1 A timeout event for Timer A of GPTM 32/64-Bit Timer 5 is triggered. 0x2 A timeout event for Timer B of GPTM 32/64-Bit Timer 5 is triggered. 0x3 A timeout event for both Timer A and Timer B of GPTM 32/64-Bit Timer 5 is triggered.

Bit/Field	Name	Type	Reset	Description										
21:20	SYNCWT4	R/W	0x0	<p>Synchronize GPTM 32/64-Bit Timer 4</p> <p>The SYNCWT4 values are defined as follows:</p> <table border="1"> <thead> <tr> <th>Value</th> <th>Description</th> </tr> </thead> <tbody> <tr> <td>0x0</td> <td>GPTM 32/64-Bit Timer 4 is not affected.</td> </tr> <tr> <td>0x1</td> <td>A timeout event for Timer A of GPTM 32/64-Bit Timer 4 is triggered.</td> </tr> <tr> <td>0x2</td> <td>A timeout event for Timer B of GPTM 32/64-Bit Timer 4 is triggered.</td> </tr> <tr> <td>0x3</td> <td>A timeout event for both Timer A and Timer B of GPTM 32/64-Bit Timer 4 is triggered.</td> </tr> </tbody> </table>	Value	Description	0x0	GPTM 32/64-Bit Timer 4 is not affected.	0x1	A timeout event for Timer A of GPTM 32/64-Bit Timer 4 is triggered.	0x2	A timeout event for Timer B of GPTM 32/64-Bit Timer 4 is triggered.	0x3	A timeout event for both Timer A and Timer B of GPTM 32/64-Bit Timer 4 is triggered.
Value	Description													
0x0	GPTM 32/64-Bit Timer 4 is not affected.													
0x1	A timeout event for Timer A of GPTM 32/64-Bit Timer 4 is triggered.													
0x2	A timeout event for Timer B of GPTM 32/64-Bit Timer 4 is triggered.													
0x3	A timeout event for both Timer A and Timer B of GPTM 32/64-Bit Timer 4 is triggered.													
19:18	SYNCWT3	R/W	0x0	<p>Synchronize GPTM 32/64-Bit Timer 3</p> <p>The SYNCWT3 values are defined as follows:</p> <table border="1"> <thead> <tr> <th>Value</th> <th>Description</th> </tr> </thead> <tbody> <tr> <td>0x0</td> <td>GPTM 32/64-Bit Timer 3 is not affected.</td> </tr> <tr> <td>0x1</td> <td>A timeout event for Timer A of GPTM 32/64-Bit Timer 3 is triggered.</td> </tr> <tr> <td>0x2</td> <td>A timeout event for Timer B of GPTM 32/64-Bit Timer 3 is triggered.</td> </tr> <tr> <td>0x3</td> <td>A timeout event for both Timer A and Timer B of GPTM 32/64-Bit Timer 3 is triggered.</td> </tr> </tbody> </table>	Value	Description	0x0	GPTM 32/64-Bit Timer 3 is not affected.	0x1	A timeout event for Timer A of GPTM 32/64-Bit Timer 3 is triggered.	0x2	A timeout event for Timer B of GPTM 32/64-Bit Timer 3 is triggered.	0x3	A timeout event for both Timer A and Timer B of GPTM 32/64-Bit Timer 3 is triggered.
Value	Description													
0x0	GPTM 32/64-Bit Timer 3 is not affected.													
0x1	A timeout event for Timer A of GPTM 32/64-Bit Timer 3 is triggered.													
0x2	A timeout event for Timer B of GPTM 32/64-Bit Timer 3 is triggered.													
0x3	A timeout event for both Timer A and Timer B of GPTM 32/64-Bit Timer 3 is triggered.													
17:16	SYNCWT2	R/W	0x0	<p>Synchronize GPTM 32/64-Bit Timer 2</p> <p>The SYNCWT2 values are defined as follows:</p> <table border="1"> <thead> <tr> <th>Value</th> <th>Description</th> </tr> </thead> <tbody> <tr> <td>0x0</td> <td>GPTM 32/64-Bit Timer 2 is not affected.</td> </tr> <tr> <td>0x1</td> <td>A timeout event for Timer A of GPTM 32/64-Bit Timer 2 is triggered.</td> </tr> <tr> <td>0x2</td> <td>A timeout event for Timer B of GPTM 32/64-Bit Timer 2 is triggered.</td> </tr> <tr> <td>0x3</td> <td>A timeout event for both Timer A and Timer B of GPTM 32/64-Bit Timer 2 is triggered.</td> </tr> </tbody> </table>	Value	Description	0x0	GPTM 32/64-Bit Timer 2 is not affected.	0x1	A timeout event for Timer A of GPTM 32/64-Bit Timer 2 is triggered.	0x2	A timeout event for Timer B of GPTM 32/64-Bit Timer 2 is triggered.	0x3	A timeout event for both Timer A and Timer B of GPTM 32/64-Bit Timer 2 is triggered.
Value	Description													
0x0	GPTM 32/64-Bit Timer 2 is not affected.													
0x1	A timeout event for Timer A of GPTM 32/64-Bit Timer 2 is triggered.													
0x2	A timeout event for Timer B of GPTM 32/64-Bit Timer 2 is triggered.													
0x3	A timeout event for both Timer A and Timer B of GPTM 32/64-Bit Timer 2 is triggered.													
15:14	SYNCWT1	R/W	0x0	<p>Synchronize GPTM 32/64-Bit Timer 1</p> <p>The SYNCWT1 values are defined as follows:</p> <table border="1"> <thead> <tr> <th>Value</th> <th>Description</th> </tr> </thead> <tbody> <tr> <td>0x0</td> <td>GPTM 32/64-Bit Timer 1 is not affected.</td> </tr> <tr> <td>0x1</td> <td>A timeout event for Timer A of GPTM 32/64-Bit Timer 1 is triggered.</td> </tr> <tr> <td>0x2</td> <td>A timeout event for Timer B of GPTM 32/64-Bit Timer 1 is triggered.</td> </tr> <tr> <td>0x3</td> <td>A timeout event for both Timer A and Timer B of GPTM 32/64-Bit Timer 1 is triggered.</td> </tr> </tbody> </table>	Value	Description	0x0	GPTM 32/64-Bit Timer 1 is not affected.	0x1	A timeout event for Timer A of GPTM 32/64-Bit Timer 1 is triggered.	0x2	A timeout event for Timer B of GPTM 32/64-Bit Timer 1 is triggered.	0x3	A timeout event for both Timer A and Timer B of GPTM 32/64-Bit Timer 1 is triggered.
Value	Description													
0x0	GPTM 32/64-Bit Timer 1 is not affected.													
0x1	A timeout event for Timer A of GPTM 32/64-Bit Timer 1 is triggered.													
0x2	A timeout event for Timer B of GPTM 32/64-Bit Timer 1 is triggered.													
0x3	A timeout event for both Timer A and Timer B of GPTM 32/64-Bit Timer 1 is triggered.													

Bit/Field	Name	Type	Reset	Description										
13:12	SYNCWT0	R/W	0x0	<p>Synchronize GPTM 32/64-Bit Timer 0</p> <p>The <i>SYNCWT0</i> values are defined as follows:</p> <table border="1"> <thead> <tr> <th>Value</th> <th>Description</th> </tr> </thead> <tbody> <tr> <td>0x0</td> <td>GPTM 32/64-Bit Timer 0 is not affected.</td> </tr> <tr> <td>0x1</td> <td>A timeout event for Timer A of GPTM 32/64-Bit Timer 0 is triggered.</td> </tr> <tr> <td>0x2</td> <td>A timeout event for Timer B of GPTM 32/64-Bit Timer 0 is triggered.</td> </tr> <tr> <td>0x3</td> <td>A timeout event for both Timer A and Timer B of GPTM 32/64-Bit Timer 0 is triggered.</td> </tr> </tbody> </table>	Value	Description	0x0	GPTM 32/64-Bit Timer 0 is not affected.	0x1	A timeout event for Timer A of GPTM 32/64-Bit Timer 0 is triggered.	0x2	A timeout event for Timer B of GPTM 32/64-Bit Timer 0 is triggered.	0x3	A timeout event for both Timer A and Timer B of GPTM 32/64-Bit Timer 0 is triggered.
Value	Description													
0x0	GPTM 32/64-Bit Timer 0 is not affected.													
0x1	A timeout event for Timer A of GPTM 32/64-Bit Timer 0 is triggered.													
0x2	A timeout event for Timer B of GPTM 32/64-Bit Timer 0 is triggered.													
0x3	A timeout event for both Timer A and Timer B of GPTM 32/64-Bit Timer 0 is triggered.													
11:10	SYNCT5	R/W	0x0	<p>Synchronize GPTM 16/32-Bit Timer 5</p> <p>The <i>SYNCT5</i> values are defined as follows:</p> <table border="1"> <thead> <tr> <th>Value</th> <th>Description</th> </tr> </thead> <tbody> <tr> <td>0x0</td> <td>GPTM 16/32-Bit Timer 5 is not affected.</td> </tr> <tr> <td>0x1</td> <td>A timeout event for Timer A of GPTM 16/32-Bit Timer 5 is triggered.</td> </tr> <tr> <td>0x2</td> <td>A timeout event for Timer B of GPTM 16/32-Bit Timer 5 is triggered.</td> </tr> <tr> <td>0x3</td> <td>A timeout event for both Timer A and Timer B of GPTM 16/32-Bit Timer 5 is triggered.</td> </tr> </tbody> </table>	Value	Description	0x0	GPTM 16/32-Bit Timer 5 is not affected.	0x1	A timeout event for Timer A of GPTM 16/32-Bit Timer 5 is triggered.	0x2	A timeout event for Timer B of GPTM 16/32-Bit Timer 5 is triggered.	0x3	A timeout event for both Timer A and Timer B of GPTM 16/32-Bit Timer 5 is triggered.
Value	Description													
0x0	GPTM 16/32-Bit Timer 5 is not affected.													
0x1	A timeout event for Timer A of GPTM 16/32-Bit Timer 5 is triggered.													
0x2	A timeout event for Timer B of GPTM 16/32-Bit Timer 5 is triggered.													
0x3	A timeout event for both Timer A and Timer B of GPTM 16/32-Bit Timer 5 is triggered.													
9:8	SYNCT4	R/W	0x0	<p>Synchronize GPTM 16/32-Bit Timer 4</p> <p>The <i>SYNCT4</i> values are defined as follows:</p> <table border="1"> <thead> <tr> <th>Value</th> <th>Description</th> </tr> </thead> <tbody> <tr> <td>0x0</td> <td>GPTM 16/32-Bit Timer 4 is not affected.</td> </tr> <tr> <td>0x1</td> <td>A timeout event for Timer A of GPTM 16/32-Bit Timer 4 is triggered.</td> </tr> <tr> <td>0x2</td> <td>A timeout event for Timer B of GPTM 16/32-Bit Timer 4 is triggered.</td> </tr> <tr> <td>0x3</td> <td>A timeout event for both Timer A and Timer B of GPTM 16/32-Bit Timer 4 is triggered.</td> </tr> </tbody> </table>	Value	Description	0x0	GPTM 16/32-Bit Timer 4 is not affected.	0x1	A timeout event for Timer A of GPTM 16/32-Bit Timer 4 is triggered.	0x2	A timeout event for Timer B of GPTM 16/32-Bit Timer 4 is triggered.	0x3	A timeout event for both Timer A and Timer B of GPTM 16/32-Bit Timer 4 is triggered.
Value	Description													
0x0	GPTM 16/32-Bit Timer 4 is not affected.													
0x1	A timeout event for Timer A of GPTM 16/32-Bit Timer 4 is triggered.													
0x2	A timeout event for Timer B of GPTM 16/32-Bit Timer 4 is triggered.													
0x3	A timeout event for both Timer A and Timer B of GPTM 16/32-Bit Timer 4 is triggered.													
7:6	SYNCT3	R/W	0x0	<p>Synchronize GPTM 16/32-Bit Timer 3</p> <p>The <i>SYNCT3</i> values are defined as follows:</p> <table border="1"> <thead> <tr> <th>Value</th> <th>Description</th> </tr> </thead> <tbody> <tr> <td>0x0</td> <td>GPTM 16/32-Bit Timer 3 is not affected.</td> </tr> <tr> <td>0x1</td> <td>A timeout event for Timer A of GPTM 16/32-Bit Timer 3 is triggered.</td> </tr> <tr> <td>0x2</td> <td>A timeout event for Timer B of GPTM 16/32-Bit Timer 3 is triggered.</td> </tr> <tr> <td>0x3</td> <td>A timeout event for both Timer A and Timer B of GPTM 16/32-Bit Timer 3 is triggered.</td> </tr> </tbody> </table>	Value	Description	0x0	GPTM 16/32-Bit Timer 3 is not affected.	0x1	A timeout event for Timer A of GPTM 16/32-Bit Timer 3 is triggered.	0x2	A timeout event for Timer B of GPTM 16/32-Bit Timer 3 is triggered.	0x3	A timeout event for both Timer A and Timer B of GPTM 16/32-Bit Timer 3 is triggered.
Value	Description													
0x0	GPTM 16/32-Bit Timer 3 is not affected.													
0x1	A timeout event for Timer A of GPTM 16/32-Bit Timer 3 is triggered.													
0x2	A timeout event for Timer B of GPTM 16/32-Bit Timer 3 is triggered.													
0x3	A timeout event for both Timer A and Timer B of GPTM 16/32-Bit Timer 3 is triggered.													

Bit/Field	Name	Type	Reset	Description										
5:4	SYNCT2	R/W	0x0	<p>Synchronize GPTM 16/32-Bit Timer 2</p> <p>The SYNCT2 values are defined as follows:</p> <table border="1"> <thead> <tr> <th>Value</th> <th>Description</th> </tr> </thead> <tbody> <tr> <td>0x0</td> <td>GPTM 16/32-Bit Timer 2 is not affected.</td> </tr> <tr> <td>0x1</td> <td>A timeout event for Timer A of GPTM 16/32-Bit Timer 2 is triggered.</td> </tr> <tr> <td>0x2</td> <td>A timeout event for Timer B of GPTM 16/32-Bit Timer 2 is triggered.</td> </tr> <tr> <td>0x3</td> <td>A timeout event for both Timer A and Timer B of GPTM 16/32-Bit Timer 2 is triggered.</td> </tr> </tbody> </table>	Value	Description	0x0	GPTM 16/32-Bit Timer 2 is not affected.	0x1	A timeout event for Timer A of GPTM 16/32-Bit Timer 2 is triggered.	0x2	A timeout event for Timer B of GPTM 16/32-Bit Timer 2 is triggered.	0x3	A timeout event for both Timer A and Timer B of GPTM 16/32-Bit Timer 2 is triggered.
Value	Description													
0x0	GPTM 16/32-Bit Timer 2 is not affected.													
0x1	A timeout event for Timer A of GPTM 16/32-Bit Timer 2 is triggered.													
0x2	A timeout event for Timer B of GPTM 16/32-Bit Timer 2 is triggered.													
0x3	A timeout event for both Timer A and Timer B of GPTM 16/32-Bit Timer 2 is triggered.													
3:2	SYNCT1	R/W	0x0	<p>Synchronize GPTM 16/32-Bit Timer 1</p> <p>The SYNCT1 values are defined as follows:</p> <table border="1"> <thead> <tr> <th>Value</th> <th>Description</th> </tr> </thead> <tbody> <tr> <td>0x0</td> <td>GPTM 16/32-Bit Timer 1 is not affected.</td> </tr> <tr> <td>0x1</td> <td>A timeout event for Timer A of GPTM 16/32-Bit Timer 1 is triggered.</td> </tr> <tr> <td>0x2</td> <td>A timeout event for Timer B of GPTM 16/32-Bit Timer 1 is triggered.</td> </tr> <tr> <td>0x3</td> <td>A timeout event for both Timer A and Timer B of GPTM 16/32-Bit Timer 1 is triggered.</td> </tr> </tbody> </table>	Value	Description	0x0	GPTM 16/32-Bit Timer 1 is not affected.	0x1	A timeout event for Timer A of GPTM 16/32-Bit Timer 1 is triggered.	0x2	A timeout event for Timer B of GPTM 16/32-Bit Timer 1 is triggered.	0x3	A timeout event for both Timer A and Timer B of GPTM 16/32-Bit Timer 1 is triggered.
Value	Description													
0x0	GPTM 16/32-Bit Timer 1 is not affected.													
0x1	A timeout event for Timer A of GPTM 16/32-Bit Timer 1 is triggered.													
0x2	A timeout event for Timer B of GPTM 16/32-Bit Timer 1 is triggered.													
0x3	A timeout event for both Timer A and Timer B of GPTM 16/32-Bit Timer 1 is triggered.													
1:0	SYNCT0	R/W	0x0	<p>Synchronize GPTM 16/32-Bit Timer 0</p> <p>The SYNCT0 values are defined as follows:</p> <table border="1"> <thead> <tr> <th>Value</th> <th>Description</th> </tr> </thead> <tbody> <tr> <td>0x0</td> <td>GPTM 16/32-Bit Timer 0 is not affected.</td> </tr> <tr> <td>0x1</td> <td>A timeout event for Timer A of GPTM 16/32-Bit Timer 0 is triggered.</td> </tr> <tr> <td>0x2</td> <td>A timeout event for Timer B of GPTM 16/32-Bit Timer 0 is triggered.</td> </tr> <tr> <td>0x3</td> <td>A timeout event for both Timer A and Timer B of GPTM 16/32-Bit Timer 0 is triggered.</td> </tr> </tbody> </table>	Value	Description	0x0	GPTM 16/32-Bit Timer 0 is not affected.	0x1	A timeout event for Timer A of GPTM 16/32-Bit Timer 0 is triggered.	0x2	A timeout event for Timer B of GPTM 16/32-Bit Timer 0 is triggered.	0x3	A timeout event for both Timer A and Timer B of GPTM 16/32-Bit Timer 0 is triggered.
Value	Description													
0x0	GPTM 16/32-Bit Timer 0 is not affected.													
0x1	A timeout event for Timer A of GPTM 16/32-Bit Timer 0 is triggered.													
0x2	A timeout event for Timer B of GPTM 16/32-Bit Timer 0 is triggered.													
0x3	A timeout event for both Timer A and Timer B of GPTM 16/32-Bit Timer 0 is triggered.													

Register 6: GPTM Interrupt Mask (GPTMIMR), offset 0x018

This register allows software to enable/disable GPTM controller-level interrupts. Setting a bit enables the corresponding interrupt, while clearing a bit disables it.

GPTM Interrupt Mask (GPTMIMR)

16/32-bit Timer 0 base: 0x4003.0000
 16/32-bit Timer 1 base: 0x4003.1000
 16/32-bit Timer 2 base: 0x4003.2000
 16/32-bit Timer 3 base: 0x4003.3000
 16/32-bit Timer 4 base: 0x4003.4000
 16/32-bit Timer 5 base: 0x4003.5000
 32/64-bit Wide Timer 0 base: 0x4003.6000
 32/64-bit Wide Timer 1 base: 0x4003.7000
 32/64-bit Wide Timer 2 base: 0x4004.C000
 32/64-bit Wide Timer 3 base: 0x4004.D000
 32/64-bit Wide Timer 4 base: 0x4004.E000
 32/64-bit Wide Timer 5 base: 0x4004.F000
 Offset 0x018
 Type R/W, reset 0x0000.0000

	31	30	29	28	27	26	25	24	23	22	21	20	19	18	17	16	
	reserved															WUEIM	
Type	RO	RO	RO	RO	RO	RO	RO	RO	RO	RO	RO	RO	RO	RO	RO	R/W	
Reset	0	0	0	0	0	0	0	0	0	0	0	0	0	0	0	0	
	15	14	13	12	11	10	9	8	7	6	5	4	3	2	1	0	
	reserved				TBMIM	CBEIM	CBMIM	TBTOIM	reserved				TAMIM	RTCIM	CAEIM	CAMIM	TATOIM
Type	RO	RO	RO	RO	R/W	R/W	R/W	R/W	RO	RO	RO	R/W	R/W	R/W	R/W	R/W	
Reset	0	0	0	0	0	0	0	0	0	0	0	0	0	0	0	0	

Bit/Field	Name	Type	Reset	Description						
31:17	reserved	RO	0x0000	Software should not rely on the value of a reserved bit. To provide compatibility with future products, the value of a reserved bit should be preserved across a read-modify-write operation.						
16	WUEIM	R/W	0	32/64-Bit Wide GPTM Write Update Error Interrupt Mask The WUEIM values are defined as follows: <table border="0"> <tr> <td>Value</td> <td>Description</td> </tr> <tr> <td>0</td> <td>Interrupt is disabled.</td> </tr> <tr> <td>1</td> <td>Interrupt is enabled.</td> </tr> </table>	Value	Description	0	Interrupt is disabled.	1	Interrupt is enabled.
Value	Description									
0	Interrupt is disabled.									
1	Interrupt is enabled.									
15:12	reserved	RO	0	Software should not rely on the value of a reserved bit. To provide compatibility with future products, the value of a reserved bit should be preserved across a read-modify-write operation.						
11	TBMIM	R/W	0	GPTM Timer B Match Interrupt Mask The TBMIM values are defined as follows: <table border="0"> <tr> <td>Value</td> <td>Description</td> </tr> <tr> <td>0</td> <td>Interrupt is disabled.</td> </tr> <tr> <td>1</td> <td>Interrupt is enabled.</td> </tr> </table>	Value	Description	0	Interrupt is disabled.	1	Interrupt is enabled.
Value	Description									
0	Interrupt is disabled.									
1	Interrupt is enabled.									

Bit/Field	Name	Type	Reset	Description
10	CBEIM	R/W	0	GPTM Timer B Capture Mode Event Interrupt Mask The CBEIM values are defined as follows: Value Description 0 Interrupt is disabled. 1 Interrupt is enabled.
9	CBMIM	R/W	0	GPTM Timer B Capture Mode Match Interrupt Mask The CBMIM values are defined as follows: Value Description 0 Interrupt is disabled. 1 Interrupt is enabled.
8	TBTOIM	R/W	0	GPTM Timer B Time-Out Interrupt Mask The TBTOIM values are defined as follows: Value Description 0 Interrupt is disabled. 1 Interrupt is enabled.
7:5	reserved	RO	0	Software should not rely on the value of a reserved bit. To provide compatibility with future products, the value of a reserved bit should be preserved across a read-modify-write operation.
4	TAMIM	R/W	0	GPTM Timer A Match Interrupt Mask The TAMIM values are defined as follows: Value Description 0 Interrupt is disabled. 1 Interrupt is enabled.
3	RTCIM	R/W	0	GPTM RTC Interrupt Mask The RTCIM values are defined as follows: Value Description 0 Interrupt is disabled. 1 Interrupt is enabled.
2	CAEIM	R/W	0	GPTM Timer A Capture Mode Event Interrupt Mask The CAEIM values are defined as follows: Value Description 0 Interrupt is disabled. 1 Interrupt is enabled.

Bit/Field	Name	Type	Reset	Description
1	CAMIM	R/W	0	GPTM Timer A Capture Mode Match Interrupt Mask The CAMIM values are defined as follows: Value Description 0 Interrupt is disabled. 1 Interrupt is enabled.
0	TATOIM	R/W	0	GPTM Timer A Time-Out Interrupt Mask The TATOIM values are defined as follows: Value Description 0 Interrupt is disabled. 1 Interrupt is enabled.

Register 7: GPTM Raw Interrupt Status (GPTMRIS), offset 0x01C

This register shows the state of the GPTM's internal interrupt signal. These bits are set whether or not the interrupt is masked in the **GPTMIMR** register. Each bit can be cleared by writing a 1 to its corresponding bit in **GPTMICR**.

GPTM Raw Interrupt Status (GPTMRIS)

16/32-bit Timer 0 base: 0x4003.0000
 16/32-bit Timer 1 base: 0x4003.1000
 16/32-bit Timer 2 base: 0x4003.2000
 16/32-bit Timer 3 base: 0x4003.3000
 16/32-bit Timer 4 base: 0x4003.4000
 16/32-bit Timer 5 base: 0x4003.5000
 32/64-bit Wide Timer 0 base: 0x4003.6000
 32/64-bit Wide Timer 1 base: 0x4003.7000
 32/64-bit Wide Timer 2 base: 0x4004.C000
 32/64-bit Wide Timer 3 base: 0x4004.D000
 32/64-bit Wide Timer 4 base: 0x4004.E000
 32/64-bit Wide Timer 5 base: 0x4004.F000
 Offset 0x01C
 Type RO, reset 0x0000.0000

	31	30	29	28	27	26	25	24	23	22	21	20	19	18	17	16	
	reserved															WUERIS	
Type	RO	RO	RO	RO	RO	RO	RO	RO	RO	RO	RO	RO	RO	RO	RO	R/W	
Reset	0	0	0	0	0	0	0	0	0	0	0	0	0	0	0	0	
	15	14	13	12	11	10	9	8	7	6	5	4	3	2	1	0	
	reserved				TBMRIS	CBERIS	CBMRIS	TBTORIS	reserved				TAMRIS	RTCRIS	CAERIS	CAMRIS	TATORIS
Type	RO	RO	RO	RO	RO	RO	RO	RO	RO	RO	RO	RO	RO	RO	RO	RO	
Reset	0	0	0	0	0	0	0	0	0	0	0	0	0	0	0	0	

Bit/Field	Name	Type	Reset	Description
31:17	reserved	RO	0x0000	Software should not rely on the value of a reserved bit. To provide compatibility with future products, the value of a reserved bit should be preserved across a read-modify-write operation.
16	WUERIS	R/W	0	32/64-Bit Wide GPTM Write Update Error Raw Interrupt Status
				Value Description
				1 Either a Timer A register or a Timer B register was written twice in a row or a Timer A register was written before the corresponding Timer B register was written.
				0 No error.
15:12	reserved	RO	0	Software should not rely on the value of a reserved bit. To provide compatibility with future products, the value of a reserved bit should be preserved across a read-modify-write operation.
11	TBMRIS	RO	0	GPTM Timer B Match Raw Interrupt
				Value Description
				1 The TBMIE bit is set in the GPTMTBMR register, and the match values in the GPTMTBMATCHR and (optionally) GPTMTBPMR registers have been reached when configured in one-shot or periodic mode.
				0 The match value has not been reached.
				This bit is cleared by writing a 1 to the TBMCINT bit in the GPTMICR register.

Bit/Field	Name	Type	Reset	Description
10	CBERIS	RO	0	<p>GPTM Timer B Capture Mode Event Raw Interrupt</p> <p>Value Description</p> <p>1 A capture mode event has occurred for Timer B. This interrupt asserts when the subtimer is configured in Input Edge-Time mode or when configured in PWM mode with the PWM interrupt enabled by setting the <code>TBPWMIE</code> bit in the <code>GPTMTBMR</code>.</p> <p>0 The capture mode event for Timer B has not occurred.</p> <p>This bit is cleared by writing a 1 to the <code>CBECINT</code> bit in the <code>GPTMICR</code> register.</p>
9	CBMRIS	RO	0	<p>GPTM Timer B Capture Mode Match Raw Interrupt</p> <p>Value Description</p> <p>1 The capture mode match has occurred for Timer B. This interrupt asserts when the values in the <code>GPTMTBR</code> and <code>GPTMTBPR</code> match the values in the <code>GPTMTBMATCHR</code> and <code>GPTMTBPMR</code> when configured in Input Edge-Time mode.</p> <p>0 The capture mode match for Timer B has not occurred.</p> <p>This bit is cleared by writing a 1 to the <code>CBMCINT</code> bit in the <code>GPTMICR</code> register.</p>
8	TBTORIS	RO	0	<p>GPTM Timer B Time-Out Raw Interrupt</p> <p>Value Description</p> <p>1 Timer B has timed out. This interrupt is asserted when a one-shot or periodic mode timer reaches its count limit (0 or the value loaded into <code>GPTMTBILR</code>, depending on the count direction).</p> <p>0 Timer B has not timed out.</p> <p>This bit is cleared by writing a 1 to the <code>TBTOCINT</code> bit in the <code>GPTMICR</code> register.</p>
7:5	reserved	RO	0	<p>Software should not rely on the value of a reserved bit. To provide compatibility with future products, the value of a reserved bit should be preserved across a read-modify-write operation.</p>
4	TAMRIS	RO	0	<p>GPTM Timer A Match Raw Interrupt</p> <p>Value Description</p> <p>1 The <code>TAMIE</code> bit is set in the <code>GPTMTAMR</code> register, and the match value in the <code>GPTMTAMATCHR</code> and (optionally) <code>GPTMTAPMR</code> registers have been reached when configured in one-shot or periodic mode.</p> <p>0 The match value has not been reached.</p> <p>This bit is cleared by writing a 1 to the <code>TAMCINT</code> bit in the <code>GPTMICR</code> register.</p>

Bit/Field	Name	Type	Reset	Description
3	RTCRIS	RO	0	<p>GPTM RTC Raw Interrupt</p> <p>Value Description</p> <p>1 The RTC event has occurred.</p> <p>0 The RTC event has not occurred.</p> <p>This bit is cleared by writing a 1 to the <code>RTCCINT</code> bit in the GPTMICR register.</p>
2	CAERIS	RO	0	<p>GPTM Timer A Capture Mode Event Raw Interrupt</p> <p>Value Description</p> <p>1 A capture mode event has occurred for Timer A. This interrupt asserts when the subtimer is configured in Input Edge-Time mode or when configured in PWM mode with the PWM interrupt enabled by setting the <code>TAPWMIIE</code> bit in the GPTMTAMR.</p> <p>0 The capture mode event for Timer A has not occurred.</p> <p>This bit is cleared by writing a 1 to the <code>CAECINT</code> bit in the GPTMICR register.</p>
1	CAMRIS	RO	0	<p>GPTM Timer A Capture Mode Match Raw Interrupt</p> <p>Value Description</p> <p>1 A capture mode match has occurred for Timer A. This interrupt asserts when the values in the GPTMTAR and GPTMTAPR match the values in the GPTMTAMATCHR and GPTMTAPMR when configured in Input Edge-Time mode.</p> <p>0 The capture mode match for Timer A has not occurred.</p> <p>This bit is cleared by writing a 1 to the <code>CAMCINT</code> bit in the GPTMICR register.</p>
0	TATORIS	RO	0	<p>GPTM Timer A Time-Out Raw Interrupt</p> <p>Value Description</p> <p>1 Timer A has timed out. This interrupt is asserted when a one-shot or periodic mode timer reaches its count limit (0 or the value loaded into GPTMTAILR, depending on the count direction).</p> <p>0 Timer A has not timed out.</p> <p>This bit is cleared by writing a 1 to the <code>TATOCINT</code> bit in the GPTMICR register.</p>

Register 8: GPTM Masked Interrupt Status (GPTMMIS), offset 0x020

This register show the state of the GPTM's controller-level interrupt. If an interrupt is unmasked in **GPTMIMR**, and there is an event that causes the interrupt to be asserted, the corresponding bit is set in this register. All bits are cleared by writing a 1 to the corresponding bit in **GPTMICR**.

GPTM Masked Interrupt Status (GPTMMIS)

16/32-bit Timer 0 base: 0x4003.0000
 16/32-bit Timer 1 base: 0x4003.1000
 16/32-bit Timer 2 base: 0x4003.2000
 16/32-bit Timer 3 base: 0x4003.3000
 16/32-bit Timer 4 base: 0x4003.4000
 16/32-bit Timer 5 base: 0x4003.5000
 32/64-bit Wide Timer 0 base: 0x4003.6000
 32/64-bit Wide Timer 1 base: 0x4003.7000
 32/64-bit Wide Timer 2 base: 0x4004.C000
 32/64-bit Wide Timer 3 base: 0x4004.D000
 32/64-bit Wide Timer 4 base: 0x4004.E000
 32/64-bit Wide Timer 5 base: 0x4004.F000
 Offset 0x020
 Type RO, reset 0x0000.0000

	31	30	29	28	27	26	25	24	23	22	21	20	19	18	17	16	
	reserved															WUEMIS	
Type	RO	RO	RO	RO	RO	RO	RO	RO	RO	RO	RO	RO	RO	RO	RO	RO	
Reset	0	0	0	0	0	0	0	0	0	0	0	0	0	0	0	0	
	15	14	13	12	11	10	9	8	7	6	5	4	3	2	1	0	
	reserved				TBMMIS	CBEMIS	CBMMIS	TBTOMIS	reserved				TAMMIS	RTCMIS	CAEMIS	CAMMIS	TATOMIS
Type	RO	RO	RO	RO	RO	RO	RO	RO	RO	RO	RO	RO	RO	RO	RO	RO	
Reset	0	0	0	0	0	0	0	0	0	0	0	0	0	0	0	0	

Bit/Field	Name	Type	Reset	Description
31:17	reserved	RO	0x0000	Software should not rely on the value of a reserved bit. To provide compatibility with future products, the value of a reserved bit should be preserved across a read-modify-write operation.
16	WUEMIS	RO	0	32/64-Bit Wide GPTM Write Update Error Masked Interrupt Status Value Description 1 An unmasked Write Update Error has occurred. 0 An unmasked Write Update Error has not occurred.
15:12	reserved	RO	0	Software should not rely on the value of a reserved bit. To provide compatibility with future products, the value of a reserved bit should be preserved across a read-modify-write operation.
11	TBMMIS	RO	0	GPTM Timer B Match Masked Interrupt Value Description 1 An unmasked Timer B Mode Match interrupt has occurred. 0 A Timer B Mode Match interrupt has not occurred or is masked. This bit is cleared by writing a 1 to the <code>TBMCINT</code> bit in the GPTMICR register.

Bit/Field	Name	Type	Reset	Description
10	CBEMIS	RO	0	<p>GPTM Timer B Capture Mode Event Masked Interrupt</p> <p>Value Description</p> <p>1 An unmasked Capture B event interrupt has occurred.</p> <p>0 A Capture B event interrupt has not occurred or is masked.</p> <p>This bit is cleared by writing a 1 to the <code>CBECINT</code> bit in the GPTMICR register.</p>
9	CBMMIS	RO	0	<p>GPTM Timer B Capture Mode Match Masked Interrupt</p> <p>Value Description</p> <p>1 An unmasked Capture B Match interrupt has occurred.</p> <p>0 A Capture B Mode Match interrupt has not occurred or is masked.</p> <p>This bit is cleared by writing a 1 to the <code>CBMCINT</code> bit in the GPTMICR register.</p>
8	TBTOMIS	RO	0	<p>GPTM Timer B Time-Out Masked Interrupt</p> <p>Value Description</p> <p>1 An unmasked Timer B Time-Out interrupt has occurred.</p> <p>0 A Timer B Time-Out interrupt has not occurred or is masked.</p> <p>This bit is cleared by writing a 1 to the <code>TBTOCINT</code> bit in the GPTMICR register.</p>
7:5	reserved	RO	0	Software should not rely on the value of a reserved bit. To provide compatibility with future products, the value of a reserved bit should be preserved across a read-modify-write operation.
4	TAMMIS	RO	0	<p>GPTM Timer A Match Masked Interrupt</p> <p>Value Description</p> <p>1 An unmasked Timer A Mode Match interrupt has occurred.</p> <p>0 A Timer A Mode Match interrupt has not occurred or is masked.</p> <p>This bit is cleared by writing a 1 to the <code>TAMCINT</code> bit in the GPTMICR register.</p>
3	RTCMIS	RO	0	<p>GPTM RTC Masked Interrupt</p> <p>Value Description</p> <p>1 An unmasked RTC event interrupt has occurred.</p> <p>0 An RTC event interrupt has not occurred or is masked.</p> <p>This bit is cleared by writing a 1 to the <code>RTCCINT</code> bit in the GPTMICR register.</p>

Bit/Field	Name	Type	Reset	Description
2	CAEMIS	RO	0	<p>GPTM Timer A Capture Mode Event Masked Interrupt</p> <p>Value Description</p> <p>1 An unmasked Capture A event interrupt has occurred.</p> <p>0 A Capture A event interrupt has not occurred or is masked.</p> <p>This bit is cleared by writing a 1 to the CAECINT bit in the GPTMICR register.</p>
1	CAMMIS	RO	0	<p>GPTM Timer A Capture Mode Match Masked Interrupt</p> <p>Value Description</p> <p>1 An unmasked Capture A Match interrupt has occurred.</p> <p>0 A Capture A Mode Match interrupt has not occurred or is masked.</p> <p>This bit is cleared by writing a 1 to the CAMCINT bit in the GPTMICR register.</p>
0	TATOMIS	RO	0	<p>GPTM Timer A Time-Out Masked Interrupt</p> <p>Value Description</p> <p>1 An unmasked Timer A Time-Out interrupt has occurred.</p> <p>0 A Timer A Time-Out interrupt has not occurred or is masked.</p> <p>This bit is cleared by writing a 1 to the TATOCINT bit in the GPTMICR register.</p>

Register 9: GPTM Interrupt Clear (GPTMICR), offset 0x024

This register is used to clear the status bits in the **GPTMRIS** and **GPTMMIS** registers. Writing a 1 to a bit clears the corresponding bit in the **GPTMRIS** and **GPTMMIS** registers.

GPTM Interrupt Clear (GPTMICR)

16/32-bit Timer 0 base: 0x4003.0000
 16/32-bit Timer 1 base: 0x4003.1000
 16/32-bit Timer 2 base: 0x4003.2000
 16/32-bit Timer 3 base: 0x4003.3000
 16/32-bit Timer 4 base: 0x4003.4000
 16/32-bit Timer 5 base: 0x4003.5000
 32/64-bit Wide Timer 0 base: 0x4003.6000
 32/64-bit Wide Timer 1 base: 0x4003.7000
 32/64-bit Wide Timer 2 base: 0x4004.C000
 32/64-bit Wide Timer 3 base: 0x4004.D000
 32/64-bit Wide Timer 4 base: 0x4004.E000
 32/64-bit Wide Timer 5 base: 0x4004.F000
 Offset 0x024
 Type W1C, reset 0x0000.0000

	31	30	29	28	27	26	25	24	23	22	21	20	19	18	17	16	
	reserved															WUECINT	
Type	RO	RO	RO	RO	RO	RO	RO	RO	RO	RO	RO	RO	RO	RO	RO	R/W	
Reset	0	0	0	0	0	0	0	0	0	0	0	0	0	0	0	0	
	15	14	13	12	11	10	9	8	7	6	5	4	3	2	1	0	
	reserved				TBMCINT	CBECINT	CBMCINT	TBTOCINT	reserved				TAMCINT	RTCCINT	CAECINT	CAMCINT	TATOCINT
Type	RO	RO	RO	RO	W1C	W1C	W1C	W1C	RO	RO	RO	W1C	W1C	W1C	W1C	W1C	
Reset	0	0	0	0	0	0	0	0	0	0	0	0	0	0	0	0	

Bit/Field	Name	Type	Reset	Description
31:17	reserved	RO	0x0000	Software should not rely on the value of a reserved bit. To provide compatibility with future products, the value of a reserved bit should be preserved across a read-modify-write operation.
16	WUECINT	R/W	0	32/64-Bit Wide GPTM Write Update Error Interrupt Clear Writing a 1 to this bit clears the WUERIS bit in the GPTMRIS register and the WUEMIS bit in the GPTMMIS register.
15:12	reserved	RO	0	Software should not rely on the value of a reserved bit. To provide compatibility with future products, the value of a reserved bit should be preserved across a read-modify-write operation.
11	TBMCINT	W1C	0	GPTM Timer B Match Interrupt Clear Writing a 1 to this bit clears the TBMRIS bit in the GPTMRIS register and the TBMMS bit in the GPTMMIS register.
10	CBECINT	W1C	0	GPTM Timer B Capture Mode Event Interrupt Clear Writing a 1 to this bit clears the CBERIS bit in the GPTMRIS register and the CBEMIS bit in the GPTMMIS register.
9	CBMCINT	W1C	0	GPTM Timer B Capture Mode Match Interrupt Clear Writing a 1 to this bit clears the CBMRIS bit in the GPTMRIS register and the CBMMIS bit in the GPTMMIS register.
8	TBTOCINT	W1C	0	GPTM Timer B Time-Out Interrupt Clear Writing a 1 to this bit clears the TBTORIS bit in the GPTMRIS register and the TBTOMIS bit in the GPTMMIS register.

Bit/Field	Name	Type	Reset	Description
7:5	reserved	RO	0	Software should not rely on the value of a reserved bit. To provide compatibility with future products, the value of a reserved bit should be preserved across a read-modify-write operation.
4	TAMCINT	W1C	0	GPTM Timer A Match Interrupt Clear Writing a 1 to this bit clears the TAMRIS bit in the GPTMRIS register and the TAMMIS bit in the GPTMMIS register.
3	RTCCINT	W1C	0	GPTM RTC Interrupt Clear Writing a 1 to this bit clears the RTCRES bit in the GPTMRIS register and the RTCMIS bit in the GPTMMIS register.
2	CAECINT	W1C	0	GPTM Timer A Capture Mode Event Interrupt Clear Writing a 1 to this bit clears the CAERIS bit in the GPTMRIS register and the CAEMIS bit in the GPTMMIS register.
1	CAMCINT	W1C	0	GPTM Timer A Capture Mode Match Interrupt Clear Writing a 1 to this bit clears the CAMRIS bit in the GPTMRIS register and the CAMMIS bit in the GPTMMIS register.
0	TATOCINT	W1C	0	GPTM Timer A Time-Out Raw Interrupt Writing a 1 to this bit clears the TATORIS bit in the GPTMRIS register and the TATOMIS bit in the GPTMMIS register.

Register 10: GPTM Timer A Interval Load (GPTMTAILR), offset 0x028

When the timer is counting down, this register is used to load the starting count value into the timer. When the timer is counting up, this register sets the upper bound for the timeout event.

When a 16/32-bit GPTM is configured to one of the 32-bit modes, **GPTMTAILR** appears as a 32-bit register (the upper 16-bits correspond to the contents of the **GPTM Timer B Interval Load (GPTMTBILR)** register). In a 16-bit mode, the upper 16 bits of this register read as 0s and have no effect on the state of **GPTMTBILR**.

When a 32/64-bit Wide GPTM is configured to one of the 64-bit modes, **GPTMTAILR** contains bits 31:0 of the 64-bit count and the **GPTM Timer B Interval Load (GPTMTBILR)** register contains bits 63:32.

GPTM Timer A Interval Load (GPTMTAILR)

16/32-bit Timer 0 base: 0x4003.0000
 16/32-bit Timer 1 base: 0x4003.1000
 16/32-bit Timer 2 base: 0x4003.2000
 16/32-bit Timer 3 base: 0x4003.3000
 16/32-bit Timer 4 base: 0x4003.4000
 16/32-bit Timer 5 base: 0x4003.5000
 32/64-bit Wide Timer 0 base: 0x4003.6000
 32/64-bit Wide Timer 1 base: 0x4003.7000
 32/64-bit Wide Timer 2 base: 0x4004.C000
 32/64-bit Wide Timer 3 base: 0x4004.D000
 32/64-bit Wide Timer 4 base: 0x4004.E000
 32/64-bit Wide Timer 5 base: 0x4004.F000
 Offset 0x028

Type R/W, reset 0xFFFF.FFFF

	31	30	29	28	27	26	25	24	23	22	21	20	19	18	17	16
	TAILR															
Type	R/W	R/W	R/W	R/W	R/W	R/W	R/W	R/W	R/W	R/W	R/W	R/W	R/W	R/W	R/W	R/W
Reset	1	1	1	1	1	1	1	1	1	1	1	1	1	1	1	1
	15	14	13	12	11	10	9	8	7	6	5	4	3	2	1	0
	TAILR															
Type	R/W	R/W	R/W	R/W	R/W	R/W	R/W	R/W	R/W	R/W	R/W	R/W	R/W	R/W	R/W	R/W
Reset	1	1	1	1	1	1	1	1	1	1	1	1	1	1	1	1

Bit/Field	Name	Type	Reset	Description
31:0	TAILR	R/W	0xFFFF.FFFF	GPTM Timer A Interval Load Register Writing this field loads the counter for Timer A. A read returns the current value of GPTMTAILR .

Register 11: GPTM Timer B Interval Load (GPTMTBILR), offset 0x02C

When the timer is counting down, this register is used to load the starting count value into the timer. When the timer is counting up, this register sets the upper bound for the timeout event.

When a 16/32-bit GPTM is configured to one of the 32-bit modes, the contents of bits 15:0 in this register are loaded into the upper 16 bits of the **GPTMTAILR** register. Reads from this register return the current value of Timer B and writes are ignored. In a 16-bit mode, bits 15:0 are used for the load value. Bits 31:16 are reserved in both cases.

When a 32/64-bit Wide GPTM is configured to one of the 64-bit modes, **GPTMTAILR** contains bits 31:0 of the 64-bit count and the **GPTMTBILR** register contains bits 63:32.

GPTM Timer B Interval Load (GPTMTBILR)

16/32-bit Timer 0 base: 0x4003.0000
 16/32-bit Timer 1 base: 0x4003.1000
 16/32-bit Timer 2 base: 0x4003.2000
 16/32-bit Timer 3 base: 0x4003.3000
 16/32-bit Timer 4 base: 0x4003.4000
 16/32-bit Timer 5 base: 0x4003.5000
 32/64-bit Wide Timer 0 base: 0x4003.6000
 32/64-bit Wide Timer 1 base: 0x4003.7000
 32/64-bit Wide Timer 2 base: 0x4004.C000
 32/64-bit Wide Timer 3 base: 0x4004.D000
 32/64-bit Wide Timer 4 base: 0x4004.E000
 32/64-bit Wide Timer 5 base: 0x4004.F000
 Offset 0x02C
 Type R/W, reset -

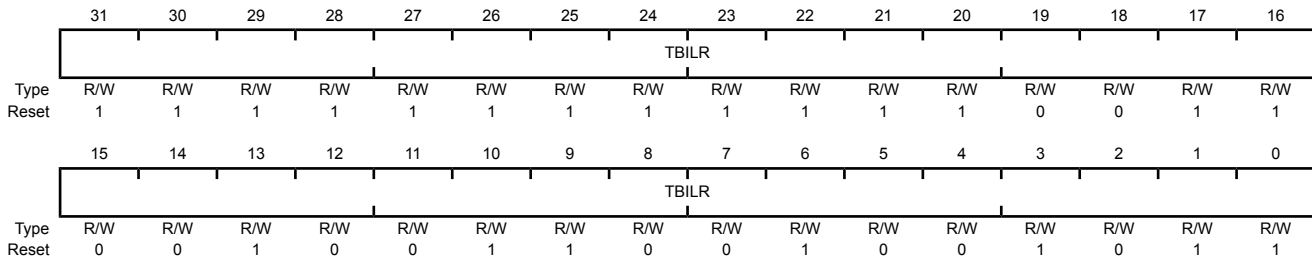

Bit/Field	Name	Type	Reset	Description
31:0	TBILR	R/W	0x0000.FFFF (for 16/32-bit) 0xFFFF.FFFF (for 32/64-bit)	GPTM Timer B Interval Load Register Writing this field loads the counter for Timer B. A read returns the current value of GPTMTBILR . When a 16/32-bit GPTM is in 32-bit mode, writes are ignored, and reads return the current value of GPTMTBILR .

Register 12: GPTM Timer A Match (GPTMTAMATCHR), offset 0x030

This register is loaded with a match value. Interrupts can be generated when the timer value is equal to the value in this register in one-shot or periodic mode.

In Edge-Count mode, this register along with **GPTMTAILR**, determines how many edge events are counted. The total number of edge events counted is equal to the value in **GPTMTAILR** minus this value.

In PWM mode, this value along with **GPTMTAILR**, determines the duty cycle of the output PWM signal.

When a 16/32-bit GPTM is configured to one of the 32-bit modes, **GPTMTAMATCHR** appears as a 32-bit register (the upper 16-bits correspond to the contents of the **GPTM Timer B Match (GPTMTBMATCHR)** register). In a 16-bit mode, the upper 16 bits of this register read as 0s and have no effect on the state of **GPTMTBMATCHR**.

When a 32/64-bit Wide GPTM is configured to one of the 64-bit modes, **GPTMTAMATCHR** contains bits 31:0 of the 64-bit match value and the **GPTM Timer B Match (GPTMTBMATCHR)** register contains bits 63:32.

GPTM Timer A Match (GPTMTAMATCHR)

16/32-bit Timer 0 base: 0x4003.0000
 16/32-bit Timer 1 base: 0x4003.1000
 16/32-bit Timer 2 base: 0x4003.2000
 16/32-bit Timer 3 base: 0x4003.3000
 16/32-bit Timer 4 base: 0x4003.4000
 16/32-bit Timer 5 base: 0x4003.5000
 32/64-bit Wide Timer 0 base: 0x4003.6000
 32/64-bit Wide Timer 1 base: 0x4003.7000
 32/64-bit Wide Timer 2 base: 0x4004.C000
 32/64-bit Wide Timer 3 base: 0x4004.D000
 32/64-bit Wide Timer 4 base: 0x4004.E000
 32/64-bit Wide Timer 5 base: 0x4004.F000
 Offset 0x030

Type R/W, reset 0xFFFF.FFFF

	31	30	29	28	27	26	25	24	23	22	21	20	19	18	17	16
	TAMR															
Type	R/W	R/W	R/W	R/W	R/W	R/W	R/W	R/W	R/W	R/W	R/W	R/W	R/W	R/W	R/W	R/W
Reset	1	1	1	1	1	1	1	1	1	1	1	1	1	1	1	1
	15	14	13	12	11	10	9	8	7	6	5	4	3	2	1	0
	TAMR															
Type	R/W	R/W	R/W	R/W	R/W	R/W	R/W	R/W	R/W	R/W	R/W	R/W	R/W	R/W	R/W	R/W
Reset	1	1	1	1	1	1	1	1	1	1	1	1	1	1	1	1

Bit/Field	Name	Type	Reset	Description
31:0	TAMR	R/W	0xFFFF.FFFF	GPTM Timer A Match Register This value is compared to the GPTMTAR register to determine match events.

Register 13: GPTM Timer B Match (GPTMTBMATCHR), offset 0x034

This register is loaded with a match value. Interrupts can be generated when the timer value is equal to the value in this register in one-shot or periodic mode.

In Edge-Count mode, this register along with **GPTMTBILR**, determines how many edge events are counted. The total number of edge events counted is equal to the value in **GPTMTBILR** minus this value.

In PWM mode, this value along with **GPTMTBILR**, determines the duty cycle of the output PWM signal.

When a 16/32-bit GPTM is configured to one of the 32-bit modes, the contents of bits 15:0 in this register are loaded into the upper 16 bits of the **GPTMTAMATCHR** register. Reads from this register return the current match value of Timer B and writes are ignored. In a 16-bit mode, bits 15:0 are used for the match value. Bits 31:16 are reserved in both cases.

When a 32/64-bit Wide GPTM is configured to one of the 64-bit modes, **GPTMTAMATCHR** contains bits 31:0 of the 64-bit match value and the **GPTMTBMATCHR** register contains bits 63:32.

GPTM Timer B Match (GPTMTBMATCHR)

16/32-bit Timer 0 base: 0x4003.0000
 16/32-bit Timer 1 base: 0x4003.1000
 16/32-bit Timer 2 base: 0x4003.2000
 16/32-bit Timer 3 base: 0x4003.3000
 16/32-bit Timer 4 base: 0x4003.4000
 16/32-bit Timer 5 base: 0x4003.5000
 32/64-bit Wide Timer 0 base: 0x4003.6000
 32/64-bit Wide Timer 1 base: 0x4003.7000
 32/64-bit Wide Timer 2 base: 0x4004.C000
 32/64-bit Wide Timer 3 base: 0x4004.D000
 32/64-bit Wide Timer 4 base: 0x4004.E000
 32/64-bit Wide Timer 5 base: 0x4004.F000
 Offset 0x034
 Type R/W, reset -

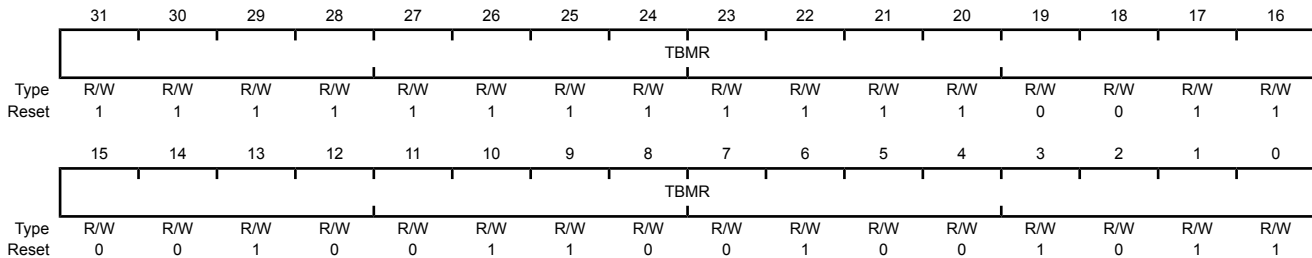

Bit/Field	Name	Type	Reset	Description
31:0	TBMR	R/W	0x0000.FFFF (for 16/32-bit) 0xFFFF.FFFF (for 32/64-bit)	GPTM Timer B Match Register This value is compared to the GPTMTBR register to determine match events.

Register 14: GPTM Timer A Prescale (GPTMTAPR), offset 0x038

This register allows software to extend the range of the timers when they are used individually. When in one-shot or periodic down count modes, this register acts as a true prescaler for the timer counter. When acting as a true prescaler, the prescaler counts down to 0 before the value in the **GPTMTAR** and **GPTMTAV** registers are incremented. In all other individual/split modes, this register is a linear extension of the upper range of the timer counter, holding bits 23:16 in the 16-bit modes of the 16/32-bit GPTM and bits 47:32 in the 32-bit modes of the 32/64-bit Wide GPTM.

GPTM Timer A Prescale (GPTMTAPR)

16/32-bit Timer 0 base: 0x4003.0000
 16/32-bit Timer 1 base: 0x4003.1000
 16/32-bit Timer 2 base: 0x4003.2000
 16/32-bit Timer 3 base: 0x4003.3000
 16/32-bit Timer 4 base: 0x4003.4000
 16/32-bit Timer 5 base: 0x4003.5000
 32/64-bit Wide Timer 0 base: 0x4003.6000
 32/64-bit Wide Timer 1 base: 0x4003.7000
 32/64-bit Wide Timer 2 base: 0x4004.C000
 32/64-bit Wide Timer 3 base: 0x4004.D000
 32/64-bit Wide Timer 4 base: 0x4004.E000
 32/64-bit Wide Timer 5 base: 0x4004.F000
 Offset 0x038
 Type R/W, reset 0x0000.0000

	31	30	29	28	27	26	25	24	23	22	21	20	19	18	17	16
	reserved															
Type	RO	RO	RO	RO	RO	RO	RO	RO	RO	RO	RO	RO	RO	RO	RO	RO
Reset	0	0	0	0	0	0	0	0	0	0	0	0	0	0	0	0
	15	14	13	12	11	10	9	8	7	6	5	4	3	2	1	0
	TAPSRH								TAPSR							
Type	R/W	R/W	R/W	R/W	R/W	R/W	R/W	R/W	R/W	R/W	R/W	R/W	R/W	R/W	R/W	R/W
Reset	0	0	0	0	0	0	0	0	0	0	0	0	0	0	0	0

Bit/Field	Name	Type	Reset	Description
31:16	reserved	RO	0	Software should not rely on the value of a reserved bit. To provide compatibility with future products, the value of a reserved bit should be preserved across a read-modify-write operation.
15:8	TAPSRH	R/W	0x00	GPTM Timer A Prescale High Byte The register loads this value on a write. A read returns the current value of the register. For the 16/32-bit GPTM, this field is reserved. For the 32/64-bit Wide GPTM, this field contains the upper 8-bits of the 16-bit prescaler. Refer to Table 10-5 on page 683 for more details and an example.
7:0	TAPSR	R/W	0x00	GPTM Timer A Prescale The register loads this value on a write. A read returns the current value of the register. For the 16/32-bit GPTM, this field contains the entire 8-bit prescaler. For the 32/64-bit Wide GPTM, this field contains the lower 8-bits of the 16-bit prescaler. Refer to Table 10-5 on page 683 for more details and an example.

Register 15: GPTM Timer B Prescale (GPTMTBPR), offset 0x03C

This register allows software to extend the range of the timers when they are used individually. When in one-shot or periodic down count modes, this register acts as a true prescaler for the timer counter. When acting as a true prescaler, the prescaler counts down to 0 before the value in the **GPTMTBR** and **GPTMTBV** registers are incremented. In all other individual/split modes, this register is a linear extension of the upper range of the timer counter, holding bits 23:16 in the 16-bit modes of the 16/32-bit GPTM and bits 47:32 in the 32-bit modes of the 32/64-bit Wide GPTM.

GPTM Timer B Prescale (GPTMTBPR)

16/32-bit Timer 0 base: 0x4003.0000
 16/32-bit Timer 1 base: 0x4003.1000
 16/32-bit Timer 2 base: 0x4003.2000
 16/32-bit Timer 3 base: 0x4003.3000
 16/32-bit Timer 4 base: 0x4003.4000
 16/32-bit Timer 5 base: 0x4003.5000
 32/64-bit Wide Timer 0 base: 0x4003.6000
 32/64-bit Wide Timer 1 base: 0x4003.7000
 32/64-bit Wide Timer 2 base: 0x4004.C000
 32/64-bit Wide Timer 3 base: 0x4004.D000
 32/64-bit Wide Timer 4 base: 0x4004.E000
 32/64-bit Wide Timer 5 base: 0x4004.F000
 Offset 0x03C
 Type R/W, reset 0x0000.0000

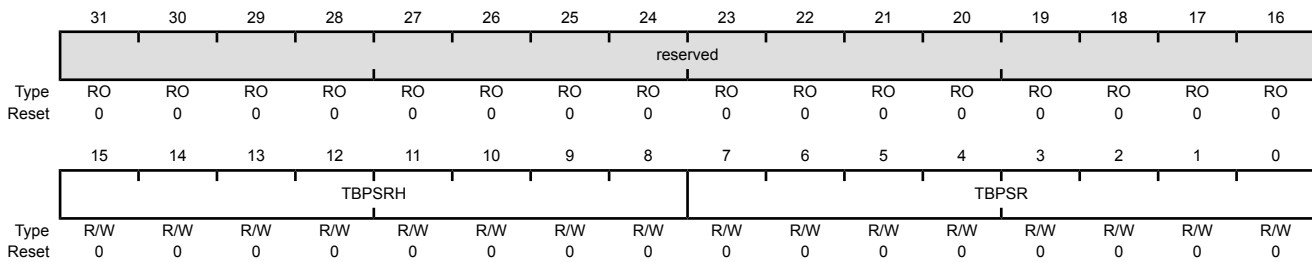

Bit/Field	Name	Type	Reset	Description
31:16	reserved	RO	0	Software should not rely on the value of a reserved bit. To provide compatibility with future products, the value of a reserved bit should be preserved across a read-modify-write operation.
15:8	TBPSRH	R/W	0x00	GPTM Timer B Prescale High Byte The register loads this value on a write. A read returns the current value of the register. For the 16/32-bit GPTM, this field is reserved. For the 32/64-bit Wide GPTM, this field contains the upper 8-bits of the 16-bit prescaler. Refer to Table 10-5 on page 683 for more details and an example.
7:0	TBPSR	R/W	0x00	GPTM Timer B Prescale The register loads this value on a write. A read returns the current value of this register. For the 16/32-bit GPTM, this field contains the entire 8-bit prescaler. For the 32/64-bit Wide GPTM, this field contains the lower 8-bits of the 16-bit prescaler. Refer to Table 10-5 on page 683 for more details and an example.

Register 16: GPTM TimerA Prescale Match (GPTMTAPMR), offset 0x040

This register allows software to extend the range of the **GPTMTAMATCHR** when the timers are used individually. This register holds bits 23:16 in the 16-bit modes of the 16/32-bit GPTM and bits 47:32 in the 32-bit modes of the 32/64-bit Wide GPTM.

GPTM TimerA Prescale Match (GPTMTAPMR)

16/32-bit Timer 0 base: 0x4003.0000
 16/32-bit Timer 1 base: 0x4003.1000
 16/32-bit Timer 2 base: 0x4003.2000
 16/32-bit Timer 3 base: 0x4003.3000
 16/32-bit Timer 4 base: 0x4003.4000
 16/32-bit Timer 5 base: 0x4003.5000
 32/64-bit Wide Timer 0 base: 0x4003.6000
 32/64-bit Wide Timer 1 base: 0x4003.7000
 32/64-bit Wide Timer 2 base: 0x4004.C000
 32/64-bit Wide Timer 3 base: 0x4004.D000
 32/64-bit Wide Timer 4 base: 0x4004.E000
 32/64-bit Wide Timer 5 base: 0x4004.F000
 Offset 0x040
 Type R/W, reset 0x0000.0000

	31	30	29	28	27	26	25	24	23	22	21	20	19	18	17	16
	reserved															
Type	RO	RO	RO	RO	RO	RO	RO	RO	RO	RO	RO	RO	RO	RO	RO	RO
Reset	0	0	0	0	0	0	0	0	0	0	0	0	0	0	0	0
	15	14	13	12	11	10	9	8	7	6	5	4	3	2	1	0
	TAPSMRH								TAPSMR							
Type	R/W	R/W	R/W	R/W	R/W	R/W	R/W	R/W	R/W	R/W	R/W	R/W	R/W	R/W	R/W	R/W
Reset	0	0	0	0	0	0	0	0	0	0	0	0	0	0	0	0

Bit/Field	Name	Type	Reset	Description
31:16	reserved	RO	0x0000	Software should not rely on the value of a reserved bit. To provide compatibility with future products, the value of a reserved bit should be preserved across a read-modify-write operation.
15:8	TAPSMRH	R/W	0x00	GPTM Timer A Prescale Match High Byte This value is used alongside GPTMTAMATCHR to detect timer match events while using a prescaler. For the 16/32-bit GPTM, this field is reserved. For the 32/64-bit Wide GPTM, this field contains the upper 8-bits of the 16-bit prescale match value.
7:0	TAPSMR	R/W	0x00	GPTM TimerA Prescale Match This value is used alongside GPTMTAMATCHR to detect timer match events while using a prescaler. For the 16/32-bit GPTM, this field contains the entire 8-bit prescaler match value. For the 32/64-bit Wide GPTM, this field contains the lower 8-bits of the 16-bit prescaler match value.

Register 17: GPTM TimerB Prescale Match (GPTMTBPMR), offset 0x044

This register allows software to extend the range of the **GPTMTBMATCHR** when the timers are used individually. This register holds bits 23:16 in the 16-bit modes of the 16/32-bit GPTM and bits 47:32 in the 32-bit modes of the 32/64-bit Wide GPTM.

GPTM TimerB Prescale Match (GPTMTBPMR)

16/32-bit Timer 0 base: 0x4003.0000
 16/32-bit Timer 1 base: 0x4003.1000
 16/32-bit Timer 2 base: 0x4003.2000
 16/32-bit Timer 3 base: 0x4003.3000
 16/32-bit Timer 4 base: 0x4003.4000
 16/32-bit Timer 5 base: 0x4003.5000
 32/64-bit Wide Timer 0 base: 0x4003.6000
 32/64-bit Wide Timer 1 base: 0x4003.7000
 32/64-bit Wide Timer 2 base: 0x4004.C000
 32/64-bit Wide Timer 3 base: 0x4004.D000
 32/64-bit Wide Timer 4 base: 0x4004.E000
 32/64-bit Wide Timer 5 base: 0x4004.F000
 Offset 0x044
 Type R/W, reset 0x0000.0000

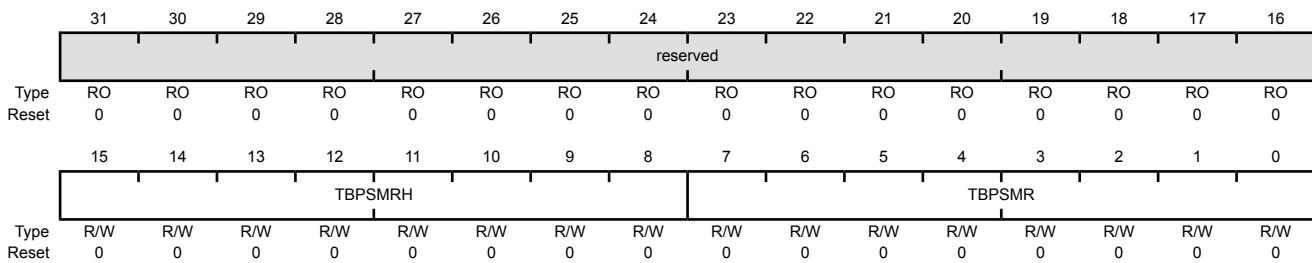

Bit/Field	Name	Type	Reset	Description
31:16	reserved	RO	0x0000	Software should not rely on the value of a reserved bit. To provide compatibility with future products, the value of a reserved bit should be preserved across a read-modify-write operation.
15:8	TBPSMRH	R/W	0x00	GPTM Timer B Prescale Match High Byte This value is used alongside GPTMTBMATCHR to detect timer match events while using a prescaler. For the 16/32-bit GPTM, this field is reserved. For the 32/64-bit Wide GPTM, this field contains the upper 8-bits of the 16-bit prescale match value.
7:0	TBPSMR	R/W	0x00	GPTM TimerB Prescale Match This value is used alongside GPTMTBMATCHR to detect timer match events while using a prescaler. For the 16/32-bit GPTM, this field contains the entire 8-bit prescaler match value. For the 32/64-bit Wide GPTM, this field contains the lower 8-bits of the 16-bit prescaler match value.

Register 18: GPTM Timer A (GPTMTAR), offset 0x048

This register shows the current value of the Timer A counter in all cases except for Input Edge Count and Time modes. In the Input Edge Count mode, this register contains the number of edges that have occurred. In the Input Edge Time mode, this register contains the time at which the last edge event took place.

When a 16/32-bit GPTM is configured to one of the 32-bit modes, **GPTMTAR** appears as a 32-bit register (the upper 16-bits correspond to the contents of the **GPTM Timer B (GPTMTBR)** register). In the 16-bit Input Edge Count, Input Edge Time, and PWM modes, bits 15:0 contain the value of the counter and bits 23:16 contain the value of the prescaler, which is the upper 8 bits of the count. Bits 31:24 always read as 0. To read the value of the prescaler in 16-bit One-Shot and Periodic modes, read bits [23:16] in the **GPTMTAV** register.

When a 32/64-bit Wide GPTM is configured to one of the 64-bit modes, **GPTMTAR** contains bits 31:0 of the 64-bit timer value and the **GPTM Timer B (GPTMTBR)** register contains bits 63:32. In a 32-bit mode, the value of the prescaler is stored in the **GPTM Timer A Prescale Snapshot (GPTMTAPS)** register.

GPTM Timer A (GPTMTAR)

16/32-bit Timer 0 base: 0x4003.0000
 16/32-bit Timer 1 base: 0x4003.1000
 16/32-bit Timer 2 base: 0x4003.2000
 16/32-bit Timer 3 base: 0x4003.3000
 16/32-bit Timer 4 base: 0x4003.4000
 16/32-bit Timer 5 base: 0x4003.5000
 32/64-bit Wide Timer 0 base: 0x4003.6000
 32/64-bit Wide Timer 1 base: 0x4003.7000
 32/64-bit Wide Timer 2 base: 0x4004.C000
 32/64-bit Wide Timer 3 base: 0x4004.D000
 32/64-bit Wide Timer 4 base: 0x4004.E000
 32/64-bit Wide Timer 5 base: 0x4004.F000
 Offset 0x048
 Type RO, reset 0xFFFF.FFFF

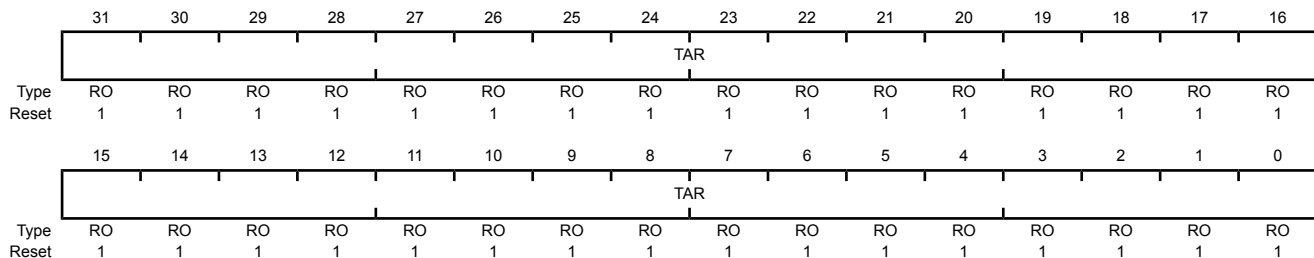

Bit/Field	Name	Type	Reset	Description
31:0	TAR	RO	0xFFFF.FFFF	GPTM Timer A Register

A read returns the current value of the **GPTM Timer A Count Register**, in all cases except for Input Edge Count and Time modes. In the Input Edge Count mode, this register contains the number of edges that have occurred. In the Input Edge Time mode, this register contains the time at which the last edge event took place.

Register 19: GPTM Timer B (GPTMTBR), offset 0x04C

This register shows the current value of the Timer B counter in all cases except for Input Edge Count and Time modes. In the Input Edge Count mode, this register contains the number of edges that have occurred. In the Input Edge Time mode, this register contains the time at which the last edge event took place.

When a 16/32-bit GPTM is configured to one of the 32-bit modes, the contents of bits 15:0 in this register are loaded into the upper 16 bits of the **GPTMTAR** register. Reads from this register return the current value of Timer B. In a 16-bit mode, bits 15:0 contain the value of the counter and bits 23:16 contain the value of the prescaler in Input Edge Count, Input Edge Time, and PWM modes, which is the upper 8 bits of the count. Bits 31:24 always read as 0. To read the value of the prescaler in 16-bit One-Shot and Periodic modes, read bits [23:16] in the **GPTMTBV** register.

When a 32/64-bit Wide GPTM is configured to one of the 64-bit modes, **GPTMTAR** contains bits 31:0 of the 64-bit timer value and the **GPTM Timer B (GPTMTBR)** register contains bits 63:32. In a 32-bit mode, the value of the prescaler is stored in the **GPTM Timer B Prescale Snapshot (GPTMTBPS)** register.

GPTM Timer B (GPTMTBR)

16/32-bit Timer 0 base: 0x4003.0000
 16/32-bit Timer 1 base: 0x4003.1000
 16/32-bit Timer 2 base: 0x4003.2000
 16/32-bit Timer 3 base: 0x4003.3000
 16/32-bit Timer 4 base: 0x4003.4000
 16/32-bit Timer 5 base: 0x4003.5000
 32/64-bit Wide Timer 0 base: 0x4003.6000
 32/64-bit Wide Timer 1 base: 0x4003.7000
 32/64-bit Wide Timer 2 base: 0x4004.C000
 32/64-bit Wide Timer 3 base: 0x4004.D000
 32/64-bit Wide Timer 4 base: 0x4004.E000
 32/64-bit Wide Timer 5 base: 0x4004.F000
 Offset 0x04C
 Type RO, reset -

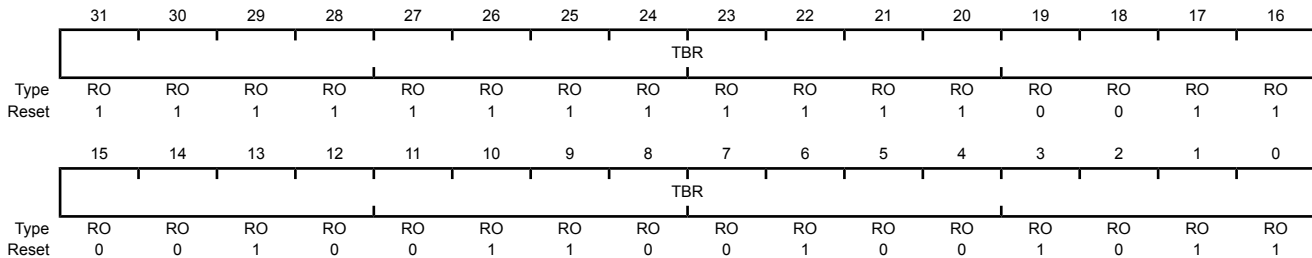

Bit/Field	Name	Type	Reset	Description
31:0	TBR	RO	0x0000.FFFF (for 16/32-bit) 0xFFFF.FFFF (for 32/64-bit)	GPTM Timer B Register A read returns the current value of the GPTM Timer B Count Register , in all cases except for Input Edge Count and Time modes. In the Input Edge Count mode, this register contains the number of edges that have occurred. In the Input Edge Time mode, this register contains the time at which the last edge event took place.

Register 20: GPTM Timer A Value (GPTMTAV), offset 0x050

When read, this register shows the current, free-running value of Timer A in all modes. Software can use this value to determine the time elapsed between an interrupt and the ISR entry when using the snapshot feature with the periodic operating mode. When written, the value written into this register is loaded into the **GPTMTAR** register on the next clock cycle.

When a 16/32-bit GPTM is configured to one of the 32-bit modes, **GPTMTAV** appears as a 32-bit register (the upper 16-bits correspond to the contents of the **GPTM Timer B Value (GPTMTBV)** register). In a 16-bit mode, bits 15:0 contain the value of the counter and bits 23:16 contain the current, free-running value of the prescaler, which is the upper 8 bits of the count in Input Edge Count, Input Edge Time, PWM and one-shot or periodic up count modes. In one-shot or periodic down count modes, the prescaler stored in 23:16 is a true prescaler, meaning bits 23:16 count down before decrementing the value in bits 15:0. The prescaler in bits 31:24 always reads as 0.

When a 32/64-bit Wide GPTM is configured to one of the 64-bit modes, **GPTMTAV** contains bits 31:0 of the 64-bit timer value and the **GPTM Timer B Value (GPTMTBV)** register contains bits 63:32. In a 32-bit mode, the current, free-running value of the prescaler is stored in the **GPTM Timer A Prescale Value (GPTMTAPV)** register.mint

GPTM Timer A Value (GPTMTAV)

16/32-bit Timer 0 base: 0x4003.0000
 16/32-bit Timer 1 base: 0x4003.1000
 16/32-bit Timer 2 base: 0x4003.2000
 16/32-bit Timer 3 base: 0x4003.3000
 16/32-bit Timer 4 base: 0x4003.4000
 16/32-bit Timer 5 base: 0x4003.5000
 32/64-bit Wide Timer 0 base: 0x4003.6000
 32/64-bit Wide Timer 1 base: 0x4003.7000
 32/64-bit Wide Timer 2 base: 0x4004.C000
 32/64-bit Wide Timer 3 base: 0x4004.D000
 32/64-bit Wide Timer 4 base: 0x4004.E000
 32/64-bit Wide Timer 5 base: 0x4004.F000
 Offset 0x050
 Type RW, reset 0xFFFF.FFFF

	31	30	29	28	27	26	25	24	23	22	21	20	19	18	17	16
	TAV															
Type	RW	RW	RW	RW	RW	RW	RW	RW	RW	RW	RW	RW	RW	RW	RW	RW
Reset	1	1	1	1	1	1	1	1	1	1	1	1	1	1	1	1
	15	14	13	12	11	10	9	8	7	6	5	4	3	2	1	0
	TAV															
Type	RW	RW	RW	RW	RW	RW	RW	RW	RW	RW	RW	RW	RW	RW	RW	RW
Reset	1	1	1	1	1	1	1	1	1	1	1	1	1	1	1	1

Bit/Field	Name	Type	Reset	Description
31:0	TAV	RW	0xFFFF.FFFF	GPTM Timer A Value A read returns the current, free-running value of Timer A in all modes. When written, the value written into this register is loaded into the GPTMTAR register on the next clock cycle.

Register 21: GPTM Timer B Value (GPTMTBV), offset 0x054

When read, this register shows the current, free-running value of Timer B in all modes. Software can use this value to determine the time elapsed between an interrupt and the ISR entry. When written, the value written into this register is loaded into the **GPTMTBR** register on the next clock cycle.

When a 16/32-bit GPTM is configured to one of the 32-bit modes, the contents of bits 15:0 in this register are loaded into the upper 16 bits of the **GPTMTAV** register. Reads from this register return the current free-running value of Timer B. In a 16-bit mode, bits 15:0 contain the value of the counter and bits 23:16 contain the current, free-running value of the prescaler, which is the upper 8 bits of the count in Input Edge Count, Input Edge Time, PWM and one-shot or periodic up count modes. In one-shot or periodic down count modes, the prescaler stored in 23:16 is a true prescaler, meaning bits 23:16 count down before decrementing the value in bits 15:0. The prescaler in bits 31:24 always reads as 0.

When a 32/64-bit Wide GPTM is configured to one of the 64-bit modes, **GPTMTBV** contains bits 63:32 of the 64-bit timer value and the **GPTM Timer A Value (GPTMTAV)** register contains bits 31:0. In a 32-bit mode, the current, free-running value of the prescaler is stored in the **GPTM Timer B Prescale Value (GPTMTBPV)** register.

GPTM Timer B Value (GPTMTBV)

16/32-bit Timer 0 base: 0x4003.0000
 16/32-bit Timer 1 base: 0x4003.1000
 16/32-bit Timer 2 base: 0x4003.2000
 16/32-bit Timer 3 base: 0x4003.3000
 16/32-bit Timer 4 base: 0x4003.4000
 16/32-bit Timer 5 base: 0x4003.5000
 32/64-bit Wide Timer 0 base: 0x4003.6000
 32/64-bit Wide Timer 1 base: 0x4003.7000
 32/64-bit Wide Timer 2 base: 0x4004.C000
 32/64-bit Wide Timer 3 base: 0x4004.D000
 32/64-bit Wide Timer 4 base: 0x4004.E000
 32/64-bit Wide Timer 5 base: 0x4004.F000
 Offset 0x054
 Type RW, reset -

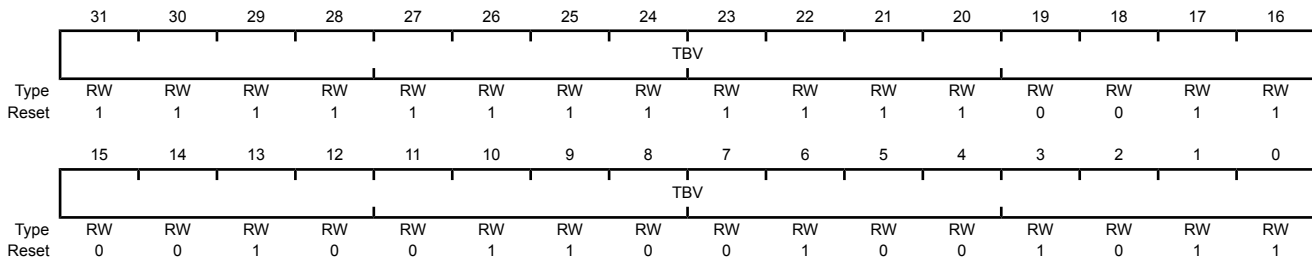

Bit/Field	Name	Type	Reset	Description
31:0	TBV	RW	0x0000.FFFF (for 16/32-bit) 0xFFFF.FFFF (for 32/64-bit)	GPTM Timer B Value A read returns the current, free-running value of Timer A in all modes. When written, the value written into this register is loaded into the GPTMTAR register on the next clock cycle.

Register 22: GPTM RTC Predivide (GPTMRTCPD), offset 0x058

This register provides the current RTC predivider value when the timer is operating in RTC mode. Software must perform an atomic access with consecutive reads of the **GPTMTAR**, **GPTMTBR**, and **GPTMRTCPD** registers, see Figure 10-2 on page 685 for more information.

GPTM RTC Predivide (GPTMRTCPD)

16/32-bit Timer 0 base: 0x4003.0000
 16/32-bit Timer 1 base: 0x4003.1000
 16/32-bit Timer 2 base: 0x4003.2000
 16/32-bit Timer 3 base: 0x4003.3000
 16/32-bit Timer 4 base: 0x4003.4000
 16/32-bit Timer 5 base: 0x4003.5000
 32/64-bit Wide Timer 0 base: 0x4003.6000
 32/64-bit Wide Timer 1 base: 0x4003.7000
 32/64-bit Wide Timer 2 base: 0x4004.C000
 32/64-bit Wide Timer 3 base: 0x4004.D000
 32/64-bit Wide Timer 4 base: 0x4004.E000
 32/64-bit Wide Timer 5 base: 0x4004.F000
 Offset 0x058
 Type RO, reset 0x0000.7FFF

	31	30	29	28	27	26	25	24	23	22	21	20	19	18	17	16
	reserved															
Type	RO	RO	RO	RO	RO	RO	RO	RO	RO	RO	RO	RO	RO	RO	RO	RO
Reset	0	0	0	0	0	0	0	0	0	0	0	0	0	0	0	0
	15	14	13	12	11	10	9	8	7	6	5	4	3	2	1	0
	RTCPD															
Type	RO	RO	RO	RO	RO	RO	RO	RO	RO	RO	RO	RO	RO	RO	RO	RO
Reset	0	1	1	1	1	1	1	1	1	1	1	1	1	1	1	1

Bit/Field	Name	Type	Reset	Description
31:16	reserved	RO	0x0000	Software should not rely on the value of a reserved bit. To provide compatibility with future products, the value of a reserved bit should be preserved across a read-modify-write operation.
15:0	RTCPD	RO	0x0000.7FFF	RTC Predivide Counter Value The current RTC predivider value when the timer is operating in RTC mode. This field has no meaning in other timer modes.

Register 23: GPTM Timer A Prescale Snapshot (GPTMTAPS), offset 0x05C

This register shows the current value of the Timer A pre-scaler in the 16-bit modes. For the 32/64-bit Wide GPTM, this register shows the current value of the Timer A prescaler in the 32-bit modes. This register is unused in 16/32-bit GPTM mode.

GPTM Timer A Prescale Snapshot (GPTMTAPS)

16/32-bit Timer 0 base: 0x4003.0000
 16/32-bit Timer 1 base: 0x4003.1000
 16/32-bit Timer 2 base: 0x4003.2000
 16/32-bit Timer 3 base: 0x4003.3000
 16/32-bit Timer 4 base: 0x4003.4000
 16/32-bit Timer 5 base: 0x4003.5000
 32/64-bit Wide Timer 0 base: 0x4003.6000
 32/64-bit Wide Timer 1 base: 0x4003.7000
 32/64-bit Wide Timer 2 base: 0x4004.C000
 32/64-bit Wide Timer 3 base: 0x4004.D000
 32/64-bit Wide Timer 4 base: 0x4004.E000
 32/64-bit Wide Timer 5 base: 0x4004.F000
 Offset 0x05C
 Type RO, reset 0x0000.0000

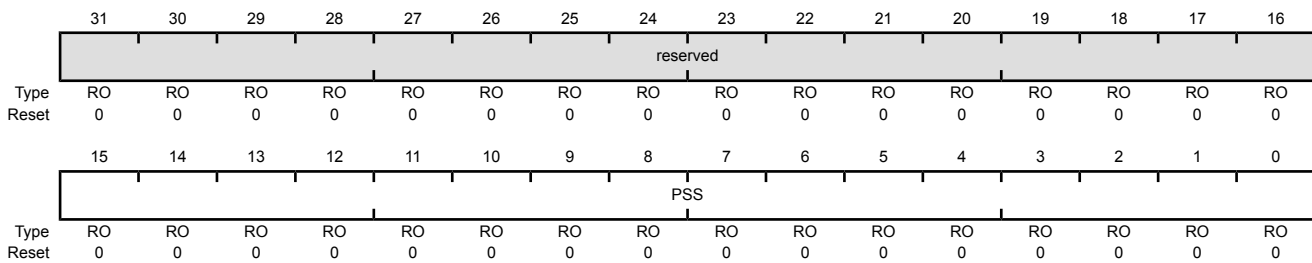

Bit/Field	Name	Type	Reset	Description
31:16	reserved	RO	0x0000	Software should not rely on the value of a reserved bit. To provide compatibility with future products, the value of a reserved bit should be preserved across a read-modify-write operation.
15:0	PSS	RO	0x0000	GPTM Timer A Prescaler Snapshot A read returns the current value of the GPTM Timer A Prescaler .

Register 24: GPTM Timer B Prescale Snapshot (GPTMTBPS), offset 0x060

This register shows the current value of the Timer B pre-scaler in the 16-bit modes. For the 32/64-bit Wide GPTM, this register shows the current value of the Timer B prescaler in the 32-bit modes. This register is unused in 16/32-bit GPTM mode.

GPTM Timer B Prescale Snapshot (GPTMTBPS)

16/32-bit Timer 0 base: 0x4003.0000
 16/32-bit Timer 1 base: 0x4003.1000
 16/32-bit Timer 2 base: 0x4003.2000
 16/32-bit Timer 3 base: 0x4003.3000
 16/32-bit Timer 4 base: 0x4003.4000
 16/32-bit Timer 5 base: 0x4003.5000
 32/64-bit Wide Timer 0 base: 0x4003.6000
 32/64-bit Wide Timer 1 base: 0x4003.7000
 32/64-bit Wide Timer 2 base: 0x4004.C000
 32/64-bit Wide Timer 3 base: 0x4004.D000
 32/64-bit Wide Timer 4 base: 0x4004.E000
 32/64-bit Wide Timer 5 base: 0x4004.F000
 Offset 0x060
 Type RO, reset 0x0000.0000

	31	30	29	28	27	26	25	24	23	22	21	20	19	18	17	16
	reserved															
Type	RO	RO	RO	RO	RO	RO	RO	RO	RO	RO	RO	RO	RO	RO	RO	RO
Reset	0	0	0	0	0	0	0	0	0	0	0	0	0	0	0	0
	15	14	13	12	11	10	9	8	7	6	5	4	3	2	1	0
	PSS															
Type	RO	RO	RO	RO	RO	RO	RO	RO	RO	RO	RO	RO	RO	RO	RO	RO
Reset	0	0	0	0	0	0	0	0	0	0	0	0	0	0	0	0

Bit/Field	Name	Type	Reset	Description
31:16	reserved	RO	0x0000	Software should not rely on the value of a reserved bit. To provide compatibility with future products, the value of a reserved bit should be preserved across a read-modify-write operation.
15:0	PSS	RO	0x0000	GPTM Timer A Prescaler Value A read returns the current value of the GPTM Timer A Prescaler .

Register 25: GPTM Timer A Prescale Value (GPTMTAPV), offset 0x064

This register shows the current value of the Timer A free running pre-scaler in the 16-bit modes. For the 32/64-bit Wide GPTM, this register shows the current free-running value of the Timer A prescaler in the 32-bit modes. Software can use this value in conjunction with the **GPTMTAV** register to determine the time elapsed between an interrupt and the ISR entry. This register is unused in 16/32-bit GPTM mode.

GPTM Timer A Prescale Value (GPTMTAPV)

16/32-bit Timer 0 base: 0x4003.0000
 16/32-bit Timer 1 base: 0x4003.1000
 16/32-bit Timer 2 base: 0x4003.2000
 16/32-bit Timer 3 base: 0x4003.3000
 16/32-bit Timer 4 base: 0x4003.4000
 16/32-bit Timer 5 base: 0x4003.5000
 32/64-bit Wide Timer 0 base: 0x4003.6000
 32/64-bit Wide Timer 1 base: 0x4003.7000
 32/64-bit Wide Timer 2 base: 0x4004.C000
 32/64-bit Wide Timer 3 base: 0x4004.D000
 32/64-bit Wide Timer 4 base: 0x4004.E000
 32/64-bit Wide Timer 5 base: 0x4004.F000
 Offset 0x064
 Type RO, reset 0x0000.0000

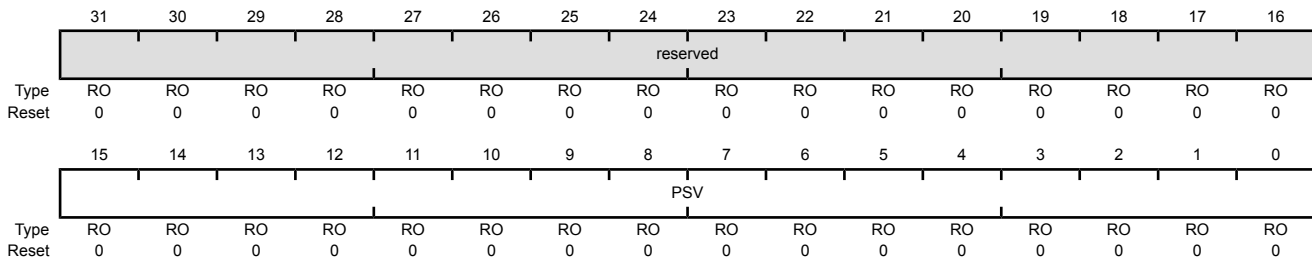

Bit/Field	Name	Type	Reset	Description
31:16	reserved	RO	0x0000	Software should not rely on the value of a reserved bit. To provide compatibility with future products, the value of a reserved bit should be preserved across a read-modify-write operation.
15:0	PSV	RO	0x0000	GPTM Timer A Prescaler Value A read returns the current, free-running value of the Timer A prescaler.

Register 26: GPTM Timer B Prescale Value (GPTMTBPV), offset 0x068

This register shows the current value of the Timer B free running pre-scaler in the 16-bit modes. For the 32/64-bit Wide GPTM, this register shows the current free-running value of the Timer B prescaler in the 32-bit modes. Software can use this value in conjunction with the **GPTMTBV** register to determine the time elapsed between an interrupt and the ISR entry. This register is unused in 16/32-bit GPTM mode.

GPTM Timer B Prescale Value (GPTMTBPV)

16/32-bit Timer 0 base: 0x4003.0000
 16/32-bit Timer 1 base: 0x4003.1000
 16/32-bit Timer 2 base: 0x4003.2000
 16/32-bit Timer 3 base: 0x4003.3000
 16/32-bit Timer 4 base: 0x4003.4000
 16/32-bit Timer 5 base: 0x4003.5000
 32/64-bit Wide Timer 0 base: 0x4003.6000
 32/64-bit Wide Timer 1 base: 0x4003.7000
 32/64-bit Wide Timer 2 base: 0x4004.C000
 32/64-bit Wide Timer 3 base: 0x4004.D000
 32/64-bit Wide Timer 4 base: 0x4004.E000
 32/64-bit Wide Timer 5 base: 0x4004.F000

Offset 0x068

Type RO, reset 0x0000.0000

	31	30	29	28	27	26	25	24	23	22	21	20	19	18	17	16
	reserved															
Type	RO	RO	RO	RO	RO	RO	RO	RO	RO	RO	RO	RO	RO	RO	RO	RO
Reset	0	0	0	0	0	0	0	0	0	0	0	0	0	0	0	0
	15	14	13	12	11	10	9	8	7	6	5	4	3	2	1	0
	PSV															
Type	RO	RO	RO	RO	RO	RO	RO	RO	RO	RO	RO	RO	RO	RO	RO	RO
Reset	0	0	0	0	0	0	0	0	0	0	0	0	0	0	0	0

Bit/Field	Name	Type	Reset	Description
31:16	reserved	RO	0x0000	Software should not rely on the value of a reserved bit. To provide compatibility with future products, the value of a reserved bit should be preserved across a read-modify-write operation.
15:0	PSV	RO	0x0000	GPTM Timer B Prescaler Value A read returns the current, free-running value of the Timer A prescaler.

Register 27: GPTM Peripheral Properties (GPTMPP), offset 0xFC0

The **GPTMPP** register provides information regarding the properties of the General-Purpose Timer module.

GPTM Peripheral Properties (GPTMPP)

16/32-bit Timer 0 base: 0x4003.0000
 16/32-bit Timer 1 base: 0x4003.1000
 16/32-bit Timer 2 base: 0x4003.2000
 16/32-bit Timer 3 base: 0x4003.3000
 16/32-bit Timer 4 base: 0x4003.4000
 16/32-bit Timer 5 base: 0x4003.5000
 32/64-bit Wide Timer 0 base: 0x4003.6000
 32/64-bit Wide Timer 1 base: 0x4003.7000
 32/64-bit Wide Timer 2 base: 0x4004.C000
 32/64-bit Wide Timer 3 base: 0x4004.D000
 32/64-bit Wide Timer 4 base: 0x4004.E000
 32/64-bit Wide Timer 5 base: 0x4004.F000
 Offset 0xFC0
 Type RO, reset 0x0000.0000

	31	30	29	28	27	26	25	24	23	22	21	20	19	18	17	16
	reserved															
Type	RO	RO	RO	RO	RO	RO	RO	RO	RO	RO	RO	RO	RO	RO	RO	RO
Reset	0	0	0	0	0	0	0	0	0	0	0	0	0	0	0	0
	15	14	13	12	11	10	9	8	7	6	5	4	3	2	1	0
	reserved												SIZE			
Type	RO	RO	RO	RO	RO	RO	RO	RO	RO	RO	RO	RO	RO	RO	RO	RO
Reset	0	0	0	0	0	0	0	0	0	0	0	0	0	0	0	0

Bit/Field	Name	Type	Reset	Description
31:4	reserved	RO	0	Software should not rely on the value of a reserved bit. To provide compatibility with future products, the value of a reserved bit should be preserved across a read-modify-write operation.
3:0	SIZE	RO	0x0	Count Size
				Value Description
			1	Timer A and Timer B counters are 32 bits each with a 16-bit prescale counter.
			0	Timer A and Timer B counters are 16 bits each with an 8-bit prescale counter.

11 Watchdog Timers

A watchdog timer can generate a non-maskable interrupt (NMI), a regular interrupt or a reset when a time-out value is reached. The watchdog timer is used to regain control when a system has failed due to a software error or due to the failure of an external device to respond in the expected way. The LM4F231H5QR microcontroller has two Watchdog Timer Modules, one module is clocked by the system clock (Watchdog Timer 0) and the other is clocked by the PIOSC (Watchdog Timer 1). The two modules are identical except that WDT1 is in a different clock domain, and therefore requires synchronizers. As a result, WDT1 has a bit defined in the **Watchdog Timer Control (WDTCTL)** register to indicate when a write to a WDT1 register is complete. Software can use this bit to ensure that the previous access has completed before starting the next access.

The Stellaris® LM4F231H5QR controller has two Watchdog Timer modules with the following features:

- 32-bit down counter with a programmable load register
- Separate watchdog clock with an enable
- Programmable interrupt generation logic with interrupt masking and optional NMI function
- Lock register protection from runaway software
- Reset generation logic with an enable/disable
- User-enabled stalling when the microcontroller asserts the CPU Halt flag during debug

The Watchdog Timer can be configured to generate an interrupt to the controller on its first time-out, and to generate a reset signal on its second time-out. Once the Watchdog Timer has been configured, the lock register can be written to prevent the timer configuration from being inadvertently altered.

11.1 Block Diagram

Figure 11-1. WDT Module Block Diagram

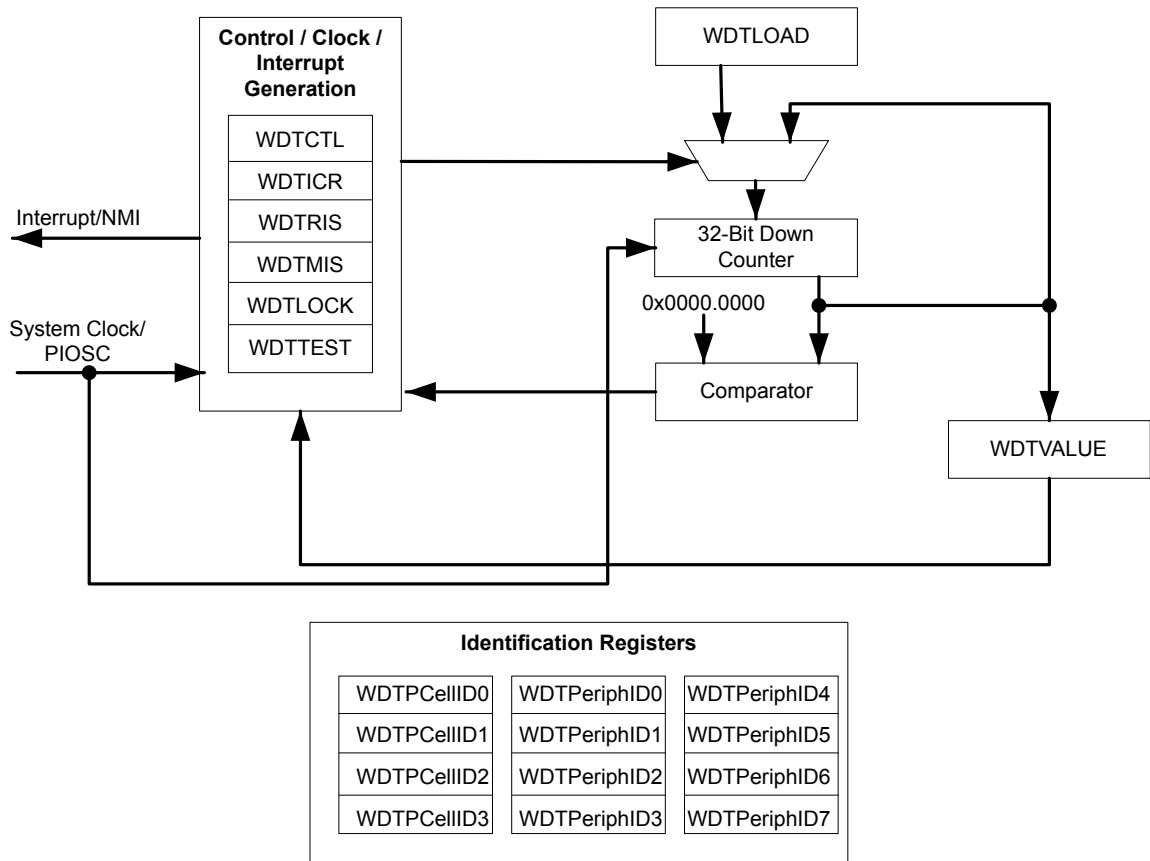

11.2 Functional Description

The Watchdog Timer module generates the first time-out signal when the 32-bit counter reaches the zero state after being enabled; enabling the counter also enables the watchdog timer interrupt. The watchdog interrupt can be programmed to be a non-maskable interrupt (NMI) using the `INTTYPE` bit in the **WDTCTL** register. After the first time-out event, the 32-bit counter is re-loaded with the value of the **Watchdog Timer Load (WDTLOAD)** register, and the timer resumes counting down from that value. Once the Watchdog Timer has been configured, the **Watchdog Timer Lock (WDTLOCK)** register is written, which prevents the timer configuration from being inadvertently altered by software.

If the timer counts down to its zero state again before the first time-out interrupt is cleared, and the reset signal has been enabled by setting the `RESEN` bit in the **WDTCTL** register, the Watchdog timer asserts its reset signal to the system. If the interrupt is cleared before the 32-bit counter reaches its second time-out, the 32-bit counter is loaded with the value in the **WDTLOAD** register, and counting resumes from that value.

If **WDTLOAD** is written with a new value while the Watchdog Timer counter is counting, then the counter is loaded with the new value and continues counting.

Writing to **WDTLOAD** does not clear an active interrupt. An interrupt must be specifically cleared by writing to the **Watchdog Interrupt Clear (WDTICR)** register.

The Watchdog module interrupt and reset generation can be enabled or disabled as required. When the interrupt is re-enabled, the 32-bit counter is preloaded with the load register value and not its last state.

11.2.1 Register Access Timing

Because the Watchdog Timer 1 module has an independent clocking domain, its registers must be written with a timing gap between accesses. Software must guarantee that this delay is inserted between back-to-back writes to WDT1 registers or between a write followed by a read to the registers. The timing for back-to-back reads from the WDT1 module has no restrictions. The **WRC** bit in the **Watchdog Control (WDTCTL)** register for WDT1 indicates that the required timing gap has elapsed. This bit is cleared on a write operation and set once the write completes, indicating to software that another write or read may be started safely. Software should poll **WDTCTL** for **WRC=1** prior to accessing another register. Note that WDT0 does not have this restriction as it runs off the system clock.

11.3 Initialization and Configuration

To use the WDT, its peripheral clock must be enabled by setting the **WDT** bit in the **RCGC0n** register, see page 463.

The Watchdog Timer is configured using the following sequence:

1. Load the **WDTLOAD** register with the desired timer load value.
2. If WDT1, wait for the **WRC** bit in the **WDTCTL** register to be set.
3. If the Watchdog is configured to trigger system resets, set the **RESEN** bit in the **WDTCTL** register.
4. If WDT1, wait for the **WRC** bit in the **WDTCTL** register to be set.
5. Set the **INTEN** bit in the **WDTCTL** register to enable the Watchdog and lock the control register.

If software requires that all of the watchdog registers are locked, the Watchdog Timer module can be fully locked by writing any value to the **WDTLOCK** register. To unlock the Watchdog Timer, write a value of 0x1ACC.E551.

To service the watchdog, periodically reload the count value into the **WDTLOAD** register to restart the count. The interrupt can be enabled using the **INTEN** bit in the **WDTCTL** register to allow the processor to attempt corrective action if the watchdog is not serviced often enough. The **RESEN** bit in **WDTCTL** can be set so that the system resets if the failure is not recoverable using the ISR.

11.4 Register Map

Table 11-1 on page 750 lists the Watchdog registers. The offset listed is a hexadecimal increment to the register's address, relative to the Watchdog Timer base address:

- WDT0: 0x4000.0000
- WDT1: 0x4000.1000

Note that the Watchdog Timer module clock must be enabled before the registers can be programmed (see page 463).

Table 11-1. Watchdog Timers Register Map

Offset	Name	Type	Reset	Description	See page
0x000	WDTLOAD	R/W	0xFFFF.FFFF	Watchdog Load	751
0x004	WDTVALUE	RO	0xFFFF.FFFF	Watchdog Value	752
0x008	WDTCTL	R/W	0x0000.0000 (WDT0) 0x8000.0000 (WDT1)	Watchdog Control	753
0x00C	WDTICR	WO	-	Watchdog Interrupt Clear	755
0x010	WDTRIS	RO	0x0000.0000	Watchdog Raw Interrupt Status	756
0x014	WDTMIS	RO	0x0000.0000	Watchdog Masked Interrupt Status	757
0x418	WDTTEST	R/W	0x0000.0000	Watchdog Test	758
0xC00	WDTLOCK	R/W	0x0000.0000	Watchdog Lock	759
0xFD0	WDTPeriphID4	RO	0x0000.0000	Watchdog Peripheral Identification 4	760
0xFD4	WDTPeriphID5	RO	0x0000.0000	Watchdog Peripheral Identification 5	761
0xFD8	WDTPeriphID6	RO	0x0000.0000	Watchdog Peripheral Identification 6	762
0xFDC	WDTPeriphID7	RO	0x0000.0000	Watchdog Peripheral Identification 7	763
0xFE0	WDTPeriphID0	RO	0x0000.0005	Watchdog Peripheral Identification 0	764
0xFE4	WDTPeriphID1	RO	0x0000.0018	Watchdog Peripheral Identification 1	765
0xFE8	WDTPeriphID2	RO	0x0000.0018	Watchdog Peripheral Identification 2	766
0xFEC	WDTPeriphID3	RO	0x0000.0001	Watchdog Peripheral Identification 3	767
0xFF0	WDTPrimeCellID0	RO	0x0000.000D	Watchdog PrimeCell Identification 0	768
0xFF4	WDTPrimeCellID1	RO	0x0000.00F0	Watchdog PrimeCell Identification 1	769
0xFF8	WDTPrimeCellID2	RO	0x0000.0006	Watchdog PrimeCell Identification 2	770
0xFFC	WDTPrimeCellID3	RO	0x0000.00B1	Watchdog PrimeCell Identification 3	771

11.5 Register Descriptions

The remainder of this section lists and describes the WDT registers, in numerical order by address offset.

Register 1: Watchdog Load (WDTLOAD), offset 0x000

This register is the 32-bit interval value used by the 32-bit counter. When this register is written, the value is immediately loaded and the counter restarts counting down from the new value. If the **WDTLOAD** register is loaded with 0x0000.0000, an interrupt is immediately generated.

Watchdog Load (WDTLOAD)

WDT0 base: 0x4000.0000

WDT1 base: 0x4000.1000

Offset 0x000

Type R/W, reset 0xFFFF.FFFF

	31	30	29	28	27	26	25	24	23	22	21	20	19	18	17	16
	WDTLOAD															
Type	R/W	R/W	R/W	R/W	R/W	R/W	R/W	R/W	R/W	R/W	R/W	R/W	R/W	R/W	R/W	R/W
Reset	1	1	1	1	1	1	1	1	1	1	1	1	1	1	1	1
	15	14	13	12	11	10	9	8	7	6	5	4	3	2	1	0
	WDTLOAD															
Type	R/W	R/W	R/W	R/W	R/W	R/W	R/W	R/W	R/W	R/W	R/W	R/W	R/W	R/W	R/W	R/W
Reset	1	1	1	1	1	1	1	1	1	1	1	1	1	1	1	1

Bit/Field	Name	Type	Reset	Description
31:0	WDTLOAD	R/W	0xFFFF.FFFF	Watchdog Load Value

Register 2: Watchdog Value (WDTVALUE), offset 0x004

This register contains the current count value of the timer.

Watchdog Value (WDTVALUE)

WDT0 base: 0x4000.0000

WDT1 base: 0x4000.1000

Offset 0x004

Type RO, reset 0xFFFF.FFFF

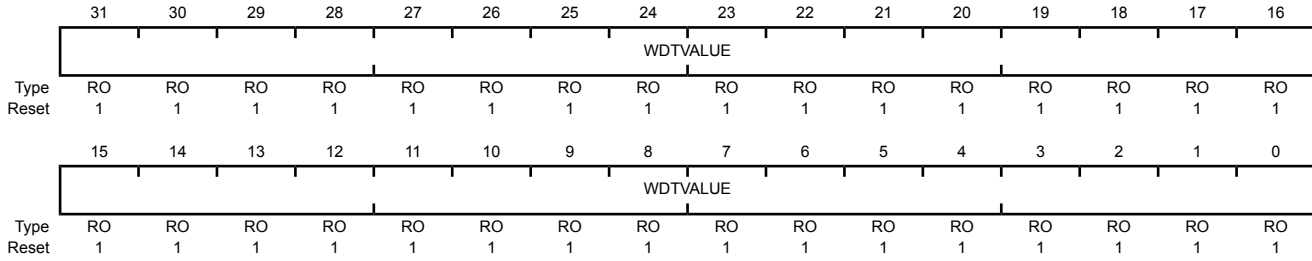

Bit/Field	Name	Type	Reset	Description
31:0	WDTVALUE	RO	0xFFFF.FFFF	Watchdog Value Current value of the 32-bit down counter.

Register 3: Watchdog Control (WDTCTL), offset 0x008

This register is the watchdog control register. The watchdog timer can be configured to generate a reset signal (on second time-out) or an interrupt on time-out.

When the watchdog interrupt has been enabled by setting the `INTEN` bit, all subsequent writes to the `INTEN` bit are ignored. The only mechanism that can re-enable writes to this bit is a hardware reset.

Important: Because the Watchdog Timer 1 module has an independent clocking domain, its registers must be written with a timing gap between accesses. Software must guarantee that this delay is inserted between back-to-back writes to WDT1 registers or between a write followed by a read to the registers. The timing for back-to-back reads from the WDT1 module has no restrictions. The `WRC` bit in the **Watchdog Control (WDTCTL)** register for WDT1 indicates that the required timing gap has elapsed. This bit is cleared on a write operation and set once the write completes, indicating to software that another write or read may be started safely. Software should poll **WDTCTL** for `WRC=1` prior to accessing another register. Note that WDT0 does not have this restriction as it runs off the system clock and therefore does not have a `WRC` bit.

Watchdog Control (WDTCTL)

WDT0 base: 0x4000.0000

WDT1 base: 0x4000.1000

Offset 0x008

Type R/W, reset 0x0000.0000 (WDT0) and 0x8000.0000 (WDT1)

	31	30	29	28	27	26	25	24	23	22	21	20	19	18	17	16	
	WRC	reserved															
Type	RO	RO	RO	RO	RO	RO	RO	RO	RO	RO	RO	RO	RO	RO	RO	RO	
Reset	1	0	0	0	0	0	0	0	0	0	0	0	0	0	0	0	
	15	14	13	12	11	10	9	8	7	6	5	4	3	2	1	0	
	reserved														INTTYPE	RESEN	INTEN
Type	RO	RO	RO	RO	RO	RO	RO	RO	RO	RO	RO	RO	RO	RO	R/W	R/W	R/W
Reset	0	0	0	0	0	0	0	0	0	0	0	0	0	0	0	0	0

Bit/Field	Name	Type	Reset	Description
31	WRC	RO	1	Write Complete The <code>WRC</code> values are defined as follows: Value Description 0 A write access to one of the WDT1 registers is in progress. 1 A write access is not in progress, and WDT1 registers can be read or written.
30:3	reserved	RO	0x000.000	Software should not rely on the value of a reserved bit. To provide compatibility with future products, the value of a reserved bit should be preserved across a read-modify-write operation.

Note: This bit is reserved for WDT0 and has a reset value of 0.

Bit/Field	Name	Type	Reset	Description
2	INTTYPE	R/W	0	Watchdog Interrupt Type The <code>INTTYPE</code> values are defined as follows: Value Description 0 Watchdog interrupt is a standard interrupt. 1 Watchdog interrupt is a non-maskable interrupt.
1	RESEN	R/W	0	Watchdog Reset Enable The <code>RESEN</code> values are defined as follows: Value Description 0 Disabled. 1 Enable the Watchdog module reset output.
0	INTEN	R/W	0	Watchdog Interrupt Enable The <code>INTEN</code> values are defined as follows: Value Description 0 Interrupt event disabled (once this bit is set, it can only be cleared by a hardware reset). 1 Interrupt event enabled. Once enabled, all writes are ignored.

Register 4: Watchdog Interrupt Clear (WDTICR), offset 0x00C

This register is the interrupt clear register. A write of any value to this register clears the Watchdog interrupt and reloads the 32-bit counter from the **WDTLOAD** register. Value for a read or reset is indeterminate.

Watchdog Interrupt Clear (WDTICR)

WDT0 base: 0x4000.0000

WDT1 base: 0x4000.1000

Offset 0x00C

Type WO, reset -

	31	30	29	28	27	26	25	24	23	22	21	20	19	18	17	16
	WDTINTCLR															
Type	WO	WO	WO	WO	WO	WO	WO	WO	WO	WO	WO	WO	WO	WO	WO	WO
Reset	-	-	-	-	-	-	-	-	-	-	-	-	-	-	-	-
	15	14	13	12	11	10	9	8	7	6	5	4	3	2	1	0
	WDTINTCLR															
Type	WO	WO	WO	WO	WO	WO	WO	WO	WO	WO	WO	WO	WO	WO	WO	WO
Reset	-	-	-	-	-	-	-	-	-	-	-	-	-	-	-	-

Bit/Field	Name	Type	Reset	Description
31:0	WDTINTCLR	WO	-	Watchdog Interrupt Clear

Register 5: Watchdog Raw Interrupt Status (WDTRIS), offset 0x010

This register is the raw interrupt status register. Watchdog interrupt events can be monitored via this register if the controller interrupt is masked.

Watchdog Raw Interrupt Status (WDTRIS)

WDT0 base: 0x4000.0000
 WDT1 base: 0x4000.1000
 Offset 0x010
 Type RO, reset 0x0000.0000

	31	30	29	28	27	26	25	24	23	22	21	20	19	18	17	16
	reserved															
Type	RO	RO	RO	RO	RO	RO	RO	RO	RO	RO	RO	RO	RO	RO	RO	RO
Reset	0	0	0	0	0	0	0	0	0	0	0	0	0	0	0	0
	15	14	13	12	11	10	9	8	7	6	5	4	3	2	1	0
	reserved															WDTRIS
Type	RO	RO	RO	RO	RO	RO	RO	RO	RO	RO	RO	RO	RO	RO	RO	RO
Reset	0	0	0	0	0	0	0	0	0	0	0	0	0	0	0	0

Bit/Field	Name	Type	Reset	Description
31:1	reserved	RO	0x0000.000	Software should not rely on the value of a reserved bit. To provide compatibility with future products, the value of a reserved bit should be preserved across a read-modify-write operation.
0	WDTRIS	RO	0	Watchdog Raw Interrupt Status
				Value Description
				1 A watchdog time-out event has occurred.
				0 The watchdog has not timed out.

Register 6: Watchdog Masked Interrupt Status (WDTMIS), offset 0x014

This register is the masked interrupt status register. The value of this register is the logical AND of the raw interrupt bit and the Watchdog interrupt enable bit.

Watchdog Masked Interrupt Status (WDTMIS)

WDT0 base: 0x4000.0000

WDT1 base: 0x4000.1000

Offset 0x014

Type RO, reset 0x0000.0000

	31	30	29	28	27	26	25	24	23	22	21	20	19	18	17	16
	reserved															
Type	RO	RO	RO	RO	RO	RO	RO	RO	RO	RO	RO	RO	RO	RO	RO	RO
Reset	0	0	0	0	0	0	0	0	0	0	0	0	0	0	0	0
	15	14	13	12	11	10	9	8	7	6	5	4	3	2	1	0
	reserved															WDTMIS
Type	RO	RO	RO	RO	RO	RO	RO	RO	RO	RO	RO	RO	RO	RO	RO	RO
Reset	0	0	0	0	0	0	0	0	0	0	0	0	0	0	0	0

Bit/Field	Name	Type	Reset	Description
31:1	reserved	RO	0x0000.000	Software should not rely on the value of a reserved bit. To provide compatibility with future products, the value of a reserved bit should be preserved across a read-modify-write operation.
0	WDTMIS	RO	0	Watchdog Masked Interrupt Status
				Value Description
				1 A watchdog time-out event has been signalled to the interrupt controller.
				0 The watchdog has not timed out or the watchdog timer interrupt is masked.

Register 7: Watchdog Test (WDTTEST), offset 0x418

This register provides user-enabled stalling when the microcontroller asserts the CPU halt flag during debug.

Watchdog Test (WDTTEST)

WDT0 base: 0x4000.0000
 WDT1 base: 0x4000.1000
 Offset 0x418
 Type R/W, reset 0x0000.0000

	31	30	29	28	27	26	25	24	23	22	21	20	19	18	17	16
	reserved															
Type	RO	RO	RO	RO	RO	RO	RO	RO	RO	RO	RO	RO	RO	RO	RO	RO
Reset	0	0	0	0	0	0	0	0	0	0	0	0	0	0	0	0
	15	14	13	12	11	10	9	8	7	6	5	4	3	2	1	0
	reserved							STALL	reserved							
Type	RO	RO	RO	RO	RO	RO	RO	R/W	RO	RO	RO	RO	RO	RO	RO	RO
Reset	0	0	0	0	0	0	0	0	0	0	0	0	0	0	0	0

Bit/Field	Name	Type	Reset	Description
31:9	reserved	RO	0x0000.00	Software should not rely on the value of a reserved bit. To provide compatibility with future products, the value of a reserved bit should be preserved across a read-modify-write operation.
8	STALL	R/W	0	Watchdog Stall Enable Value Description 1 If the microcontroller is stopped with a debugger, the watchdog timer stops counting. Once the microcontroller is restarted, the watchdog timer resumes counting. 0 The watchdog timer continues counting if the microcontroller is stopped with a debugger.
7:0	reserved	RO	0x00	Software should not rely on the value of a reserved bit. To provide compatibility with future products, the value of a reserved bit should be preserved across a read-modify-write operation.

Register 8: Watchdog Lock (WDTLOCK), offset 0xC00

Writing 0x1ACC.E551 to the **WDTLOCK** register enables write access to all other registers. Writing any other value to the **WDTLOCK** register re-enables the locked state for register writes to all the other registers. Reading the **WDTLOCK** register returns the lock status rather than the 32-bit value written. Therefore, when write accesses are disabled, reading the **WDTLOCK** register returns 0x0000.0001 (when locked; otherwise, the returned value is 0x0000.0000 (unlocked)).

Watchdog Lock (WDTLOCK)

WDT0 base: 0x4000.0000
 WDT1 base: 0x4000.1000
 Offset 0xC00
 Type R/W, reset 0x0000.0000

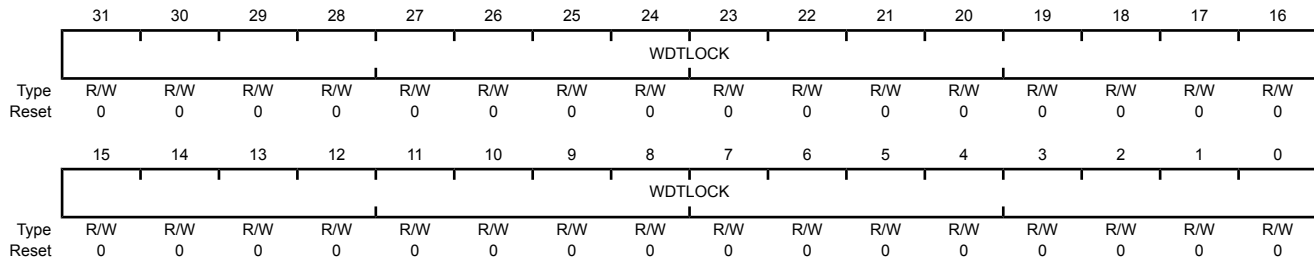

Bit/Field	Name	Type	Reset	Description
-----------	------	------	-------	-------------

31:0	WDTLOCK	R/W	0x0000.0000	Watchdog Lock
------	---------	-----	-------------	---------------

A write of the value 0x1ACC.E551 unlocks the watchdog registers for write access. A write of any other value reapplies the lock, preventing any register updates.

A read of this register returns the following values:

Value	Description
0x0000.0001	Locked
0x0000.0000	Unlocked

Register 9: Watchdog Peripheral Identification 4 (WDTPeriphID4), offset 0xFD0

The **WDTPeriphIDn** registers are hard-coded and the fields within the register determine the reset value.

Watchdog Peripheral Identification 4 (WDTPeriphID4)

WDT0 base: 0x4000.0000
 WDT1 base: 0x4000.1000
 Offset 0xFD0
 Type RO, reset 0x0000.0000

	31	30	29	28	27	26	25	24	23	22	21	20	19	18	17	16
	reserved															
Type	RO	RO	RO	RO	RO	RO	RO	RO	RO	RO	RO	RO	RO	RO	RO	RO
Reset	0	0	0	0	0	0	0	0	0	0	0	0	0	0	0	0
	15	14	13	12	11	10	9	8	7	6	5	4	3	2	1	0
	reserved								PID4							
Type	RO	RO	RO	RO	RO	RO	RO	RO	RO	RO	RO	RO	RO	RO	RO	RO
Reset	0	0	0	0	0	0	0	0	0	0	0	0	0	0	0	0

Bit/Field	Name	Type	Reset	Description
31:8	reserved	RO	0x0000.00	Software should not rely on the value of a reserved bit. To provide compatibility with future products, the value of a reserved bit should be preserved across a read-modify-write operation.
7:0	PID4	RO	0x00	WDT Peripheral ID Register [7:0]

Register 10: Watchdog Peripheral Identification 5 (WDTPeriphID5), offset 0xFD4

The **WDTPeriphIDn** registers are hard-coded and the fields within the register determine the reset value.

Watchdog Peripheral Identification 5 (WDTPeriphID5)

WDT0 base: 0x4000.0000

WDT1 base: 0x4000.1000

Offset 0xFD4

Type RO, reset 0x0000.0000

	31	30	29	28	27	26	25	24	23	22	21	20	19	18	17	16
	reserved															
Type	RO	RO	RO	RO	RO	RO	RO	RO	RO	RO	RO	RO	RO	RO	RO	RO
Reset	0	0	0	0	0	0	0	0	0	0	0	0	0	0	0	0
	15	14	13	12	11	10	9	8	7	6	5	4	3	2	1	0
	reserved								PID5							
Type	RO	RO	RO	RO	RO	RO	RO	RO	RO	RO	RO	RO	RO	RO	RO	RO
Reset	0	0	0	0	0	0	0	0	0	0	0	0	0	0	0	0

Bit/Field	Name	Type	Reset	Description
31:8	reserved	RO	0x0000.00	Software should not rely on the value of a reserved bit. To provide compatibility with future products, the value of a reserved bit should be preserved across a read-modify-write operation.
7:0	PID5	RO	0x00	WDT Peripheral ID Register [15:8]

Register 11: Watchdog Peripheral Identification 6 (WDTPeriphID6), offset 0xFD8

The **WDTPeriphIDn** registers are hard-coded and the fields within the register determine the reset value.

Watchdog Peripheral Identification 6 (WDTPeriphID6)

WDT0 base: 0x4000.0000
 WDT1 base: 0x4000.1000
 Offset 0xFD8
 Type RO, reset 0x0000.0000

	31	30	29	28	27	26	25	24	23	22	21	20	19	18	17	16
	reserved															
Type	RO	RO	RO	RO	RO	RO	RO	RO	RO	RO	RO	RO	RO	RO	RO	RO
Reset	0	0	0	0	0	0	0	0	0	0	0	0	0	0	0	0
	15	14	13	12	11	10	9	8	7	6	5	4	3	2	1	0
	reserved								PID6							
Type	RO	RO	RO	RO	RO	RO	RO	RO	RO	RO	RO	RO	RO	RO	RO	RO
Reset	0	0	0	0	0	0	0	0	0	0	0	0	0	0	0	0

Bit/Field	Name	Type	Reset	Description
31:8	reserved	RO	0x0000.00	Software should not rely on the value of a reserved bit. To provide compatibility with future products, the value of a reserved bit should be preserved across a read-modify-write operation.
7:0	PID6	RO	0x00	WDT Peripheral ID Register [23:16]

Register 12: Watchdog Peripheral Identification 7 (WDTPeriphID7), offset 0xFDC

The **WDTPeriphIDn** registers are hard-coded and the fields within the register determine the reset value.

Watchdog Peripheral Identification 7 (WDTPeriphID7)

WDT0 base: 0x4000.0000

WDT1 base: 0x4000.1000

Offset 0xFDC

Type RO, reset 0x0000.0000

	31	30	29	28	27	26	25	24	23	22	21	20	19	18	17	16
	reserved															
Type	RO	RO	RO	RO	RO	RO	RO	RO	RO	RO	RO	RO	RO	RO	RO	RO
Reset	0	0	0	0	0	0	0	0	0	0	0	0	0	0	0	0
	15	14	13	12	11	10	9	8	7	6	5	4	3	2	1	0
	reserved								PID7							
Type	RO	RO	RO	RO	RO	RO	RO	RO	RO	RO	RO	RO	RO	RO	RO	RO
Reset	0	0	0	0	0	0	0	0	0	0	0	0	0	0	0	0

Bit/Field	Name	Type	Reset	Description
31:8	reserved	RO	0x0000.00	Software should not rely on the value of a reserved bit. To provide compatibility with future products, the value of a reserved bit should be preserved across a read-modify-write operation.
7:0	PID7	RO	0x00	WDT Peripheral ID Register [31:24]

Register 13: Watchdog Peripheral Identification 0 (WDTPeriphID0), offset 0xFE0

The **WDTPeriphIDn** registers are hard-coded and the fields within the register determine the reset value.

Watchdog Peripheral Identification 0 (WDTPeriphID0)

WDT0 base: 0x4000.0000
 WDT1 base: 0x4000.1000
 Offset 0xFE0
 Type RO, reset 0x0000.0005

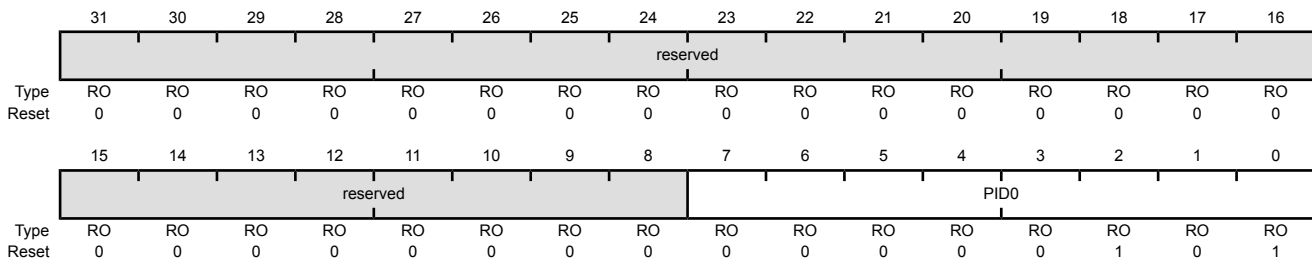

Bit/Field	Name	Type	Reset	Description
31:8	reserved	RO	0x0000.00	Software should not rely on the value of a reserved bit. To provide compatibility with future products, the value of a reserved bit should be preserved across a read-modify-write operation.
7:0	PID0	RO	0x05	Watchdog Peripheral ID Register [7:0]

Register 14: Watchdog Peripheral Identification 1 (WDTPeriphID1), offset 0xFE4

The **WDTPeriphIDn** registers are hard-coded and the fields within the register determine the reset value.

Watchdog Peripheral Identification 1 (WDTPeriphID1)

WDT0 base: 0x4000.0000

WDT1 base: 0x4000.1000

Offset 0xFE4

Type RO, reset 0x0000.0018

	31	30	29	28	27	26	25	24	23	22	21	20	19	18	17	16
	reserved															
Type	RO	RO	RO	RO	RO	RO	RO	RO	RO	RO	RO	RO	RO	RO	RO	RO
Reset	0	0	0	0	0	0	0	0	0	0	0	0	0	0	0	0
	15	14	13	12	11	10	9	8	7	6	5	4	3	2	1	0
	reserved								PID1							
Type	RO	RO	RO	RO	RO	RO	RO	RO	RO	RO	RO	RO	RO	RO	RO	RO
Reset	0	0	0	0	0	0	0	0	0	0	0	0	1	1	0	0

Bit/Field	Name	Type	Reset	Description
31:8	reserved	RO	0x0000.00	Software should not rely on the value of a reserved bit. To provide compatibility with future products, the value of a reserved bit should be preserved across a read-modify-write operation.
7:0	PID1	RO	0x18	Watchdog Peripheral ID Register [15:8]

Register 15: Watchdog Peripheral Identification 2 (WDTPeriphID2), offset 0xFE8

The **WDTPeriphIDn** registers are hard-coded and the fields within the register determine the reset value.

Watchdog Peripheral Identification 2 (WDTPeriphID2)

WDT0 base: 0x4000.0000
 WDT1 base: 0x4000.1000
 Offset 0xFE8
 Type RO, reset 0x0000.0018

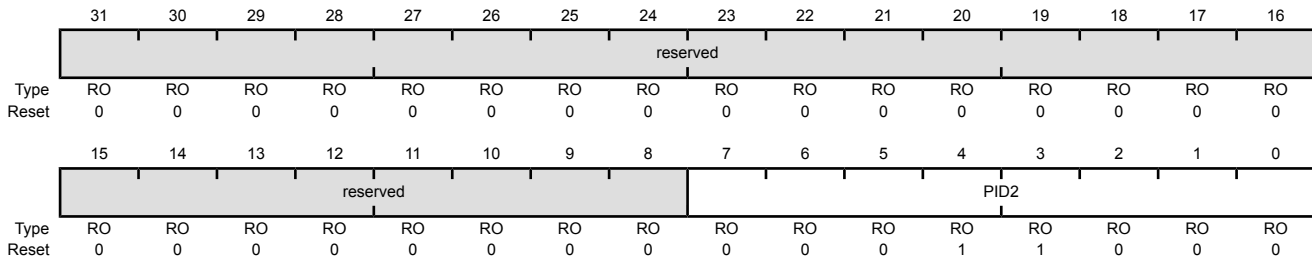

Bit/Field	Name	Type	Reset	Description
31:8	reserved	RO	0x0000.00	Software should not rely on the value of a reserved bit. To provide compatibility with future products, the value of a reserved bit should be preserved across a read-modify-write operation.
7:0	PID2	RO	0x18	Watchdog Peripheral ID Register [23:16]

Register 16: Watchdog Peripheral Identification 3 (WDTPeriphID3), offset 0xFEC

The **WDTPeriphIDn** registers are hard-coded and the fields within the register determine the reset value.

Watchdog Peripheral Identification 3 (WDTPeriphID3)

WDT0 base: 0x4000.0000

WDT1 base: 0x4000.1000

Offset 0xFEC

Type RO, reset 0x0000.0001

	31	30	29	28	27	26	25	24	23	22	21	20	19	18	17	16
	reserved															
Type	RO	RO	RO	RO	RO	RO	RO	RO	RO	RO	RO	RO	RO	RO	RO	RO
Reset	0	0	0	0	0	0	0	0	0	0	0	0	0	0	0	0
	15	14	13	12	11	10	9	8	7	6	5	4	3	2	1	0
	reserved								PID3							
Type	RO	RO	RO	RO	RO	RO	RO	RO	RO	RO	RO	RO	RO	RO	RO	RO
Reset	0	0	0	0	0	0	0	0	0	0	0	0	0	0	0	1

Bit/Field	Name	Type	Reset	Description
31:8	reserved	RO	0x0000.00	Software should not rely on the value of a reserved bit. To provide compatibility with future products, the value of a reserved bit should be preserved across a read-modify-write operation.
7:0	PID3	RO	0x01	Watchdog Peripheral ID Register [31:24]

Register 17: Watchdog PrimeCell Identification 0 (WDTPCellID0), offset 0xFF0

The **WDTPCellIDn** registers are hard-coded and the fields within the register determine the reset value.

Watchdog PrimeCell Identification 0 (WDTPCellID0)

WDT0 base: 0x4000.0000
 WDT1 base: 0x4000.1000
 Offset 0xFF0
 Type RO, reset 0x0000.000D

	31	30	29	28	27	26	25	24	23	22	21	20	19	18	17	16
	reserved															
Type	RO	RO	RO	RO	RO	RO	RO	RO	RO	RO	RO	RO	RO	RO	RO	RO
Reset	0	0	0	0	0	0	0	0	0	0	0	0	0	0	0	0
	15	14	13	12	11	10	9	8	7	6	5	4	3	2	1	0
	reserved								CID0							
Type	RO	RO	RO	RO	RO	RO	RO	RO	RO	RO	RO	RO	RO	RO	RO	RO
Reset	0	0	0	0	0	0	0	0	0	0	0	0	1	1	0	1

Bit/Field	Name	Type	Reset	Description
31:8	reserved	RO	0x0000.00	Software should not rely on the value of a reserved bit. To provide compatibility with future products, the value of a reserved bit should be preserved across a read-modify-write operation.
7:0	CID0	RO	0x0D	Watchdog PrimeCell ID Register [7:0]

Register 18: Watchdog PrimeCell Identification 1 (WDTPCellID1), offset 0xFF4

The **WDTPCellIDn** registers are hard-coded and the fields within the register determine the reset value.

Watchdog PrimeCell Identification 1 (WDTPCellID1)

WDT0 base: 0x4000.0000

WDT1 base: 0x4000.1000

Offset 0xFF4

Type RO, reset 0x0000.00F0

	31	30	29	28	27	26	25	24	23	22	21	20	19	18	17	16
	reserved															
Type	RO	RO	RO	RO	RO	RO	RO	RO	RO	RO	RO	RO	RO	RO	RO	RO
Reset	0	0	0	0	0	0	0	0	0	0	0	0	0	0	0	0
	15	14	13	12	11	10	9	8	7	6	5	4	3	2	1	0
	reserved								CID1							
Type	RO	RO	RO	RO	RO	RO	RO	RO	RO	RO	RO	RO	RO	RO	RO	RO
Reset	0	0	0	0	0	0	0	0	1	1	1	1	0	0	0	0

Bit/Field	Name	Type	Reset	Description
31:8	reserved	RO	0x0000.00	Software should not rely on the value of a reserved bit. To provide compatibility with future products, the value of a reserved bit should be preserved across a read-modify-write operation.
7:0	CID1	RO	0xF0	Watchdog PrimeCell ID Register [15:8]

Register 19: Watchdog PrimeCell Identification 2 (WDTPCellID2), offset 0xFF8

The **WDTPCellIDn** registers are hard-coded and the fields within the register determine the reset value.

Watchdog PrimeCell Identification 2 (WDTPCellID2)

WDT0 base: 0x4000.0000
 WDT1 base: 0x4000.1000
 Offset 0xFF8
 Type RO, reset 0x0000.0006

	31	30	29	28	27	26	25	24	23	22	21	20	19	18	17	16
	reserved															
Type	RO	RO	RO	RO	RO	RO	RO	RO	RO	RO	RO	RO	RO	RO	RO	RO
Reset	0	0	0	0	0	0	0	0	0	0	0	0	0	0	0	0
	15	14	13	12	11	10	9	8	7	6	5	4	3	2	1	0
	reserved								CID2							
Type	RO	RO	RO	RO	RO	RO	RO	RO	RO	RO	RO	RO	RO	RO	RO	RO
Reset	0	0	0	0	0	0	0	0	0	0	0	0	0	0	1	1

Bit/Field	Name	Type	Reset	Description
31:8	reserved	RO	0x0000.00	Software should not rely on the value of a reserved bit. To provide compatibility with future products, the value of a reserved bit should be preserved across a read-modify-write operation.
7:0	CID2	RO	0x06	Watchdog PrimeCell ID Register [23:16]

Register 20: Watchdog PrimeCell Identification 3 (WDTPCellID3), offset 0xFFC

The **WDTPCellIDn** registers are hard-coded and the fields within the register determine the reset value.

Watchdog PrimeCell Identification 3 (WDTPCellID3)

WDT0 base: 0x4000.0000

WDT1 base: 0x4000.1000

Offset 0xFFC

Type RO, reset 0x0000.00B1

	31	30	29	28	27	26	25	24	23	22	21	20	19	18	17	16
	reserved															
Type	RO	RO	RO	RO	RO	RO	RO	RO	RO	RO	RO	RO	RO	RO	RO	RO
Reset	0	0	0	0	0	0	0	0	0	0	0	0	0	0	0	0
	15	14	13	12	11	10	9	8	7	6	5	4	3	2	1	0
	reserved								CID3							
Type	RO	RO	RO	RO	RO	RO	RO	RO	RO	RO	RO	RO	RO	RO	RO	RO
Reset	0	0	0	0	0	0	0	0	1	0	1	1	0	0	0	1

Bit/Field	Name	Type	Reset	Description
31:8	reserved	RO	0x0000.00	Software should not rely on the value of a reserved bit. To provide compatibility with future products, the value of a reserved bit should be preserved across a read-modify-write operation.
7:0	CID3	RO	0xB1	Watchdog PrimeCell ID Register [31:24]

12 Analog-to-Digital Converter (ADC)

An analog-to-digital converter (ADC) is a peripheral that converts a continuous analog voltage to a discrete digital number. Two identical converter modules are included, which share 12 input channels.

The Stellaris[®] ADC module features 12-bit conversion resolution and supports 12 input channels, plus an internal temperature sensor. Each ADC module contains four programmable sequencers allowing the sampling of multiple analog input sources without controller intervention. Each sample sequencer provides flexible programming with fully configurable input source, trigger events, interrupt generation, and sequencer priority. A digital comparator function is included which allows the conversion value to be diverted to a digital comparator module. Each ADC module provides eight digital comparators. Each digital comparator evaluates the ADC conversion value against its two user-defined values to determine the operational range of the signal. The trigger source for ADC0 and ADC1 may be independent or the two ADC modules may operate from the same trigger source and operate on the same or different inputs. A phase shifter can delay the start of sampling by a specified phase angle. When using both ADC modules, it is possible to configure the converters to start the conversions coincidentally or within a relative phase from each other, see “Sample Phase Control” on page 777.

The Stellaris LM4F231H5QR microcontroller provides two ADC modules with each having the following features:

- 12 shared analog input channels
- 12-bit precision ADC
- Single-ended and differential-input configurations
- On-chip internal temperature sensor
- Maximum sample rate of one million samples/second
- Optional phase shift in sample time programmable from 22.5° to 337.5°
- Four programmable sample conversion sequencers from one to eight entries long, with corresponding conversion result FIFOs
- Flexible trigger control
 - Controller (software)
 - Timers
 - Analog Comparators
 - PWM
 - GPIO
- Hardware averaging of up to 64 samples
- Digital comparison unit providing eight digital comparators
- Converter uses VDDA and GNDA as the voltage reference

- Power and ground for the analog circuitry is separate from the digital power and ground
- Efficient transfers using Micro Direct Memory Access Controller (μ DMA)
 - Dedicated channel for each sample sequencer
 - ADC module uses burst requests for DMA

12.1 Block Diagram

The Stellaris microcontroller contains two identical Analog-to-Digital Converter modules. These two modules, ADC0 and ADC1, share the same 12 analog input channels. Each ADC module operates independently and can therefore execute different sample sequences, sample any of the analog input channels at any time, and generate different interrupts and triggers. Figure 12-1 on page 773 shows how the two modules are connected to analog inputs and the system bus.

Figure 12-1. Implementation of Two ADC Blocks

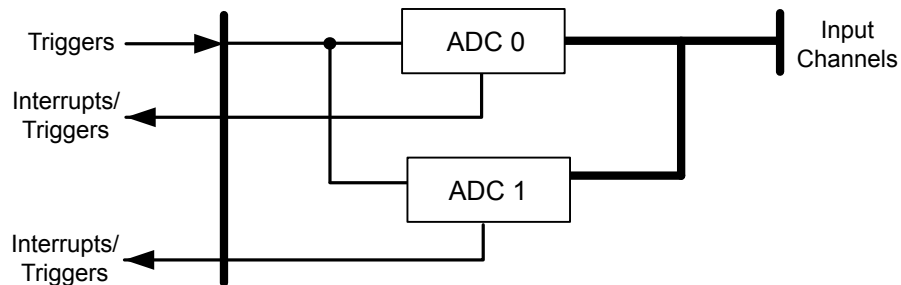
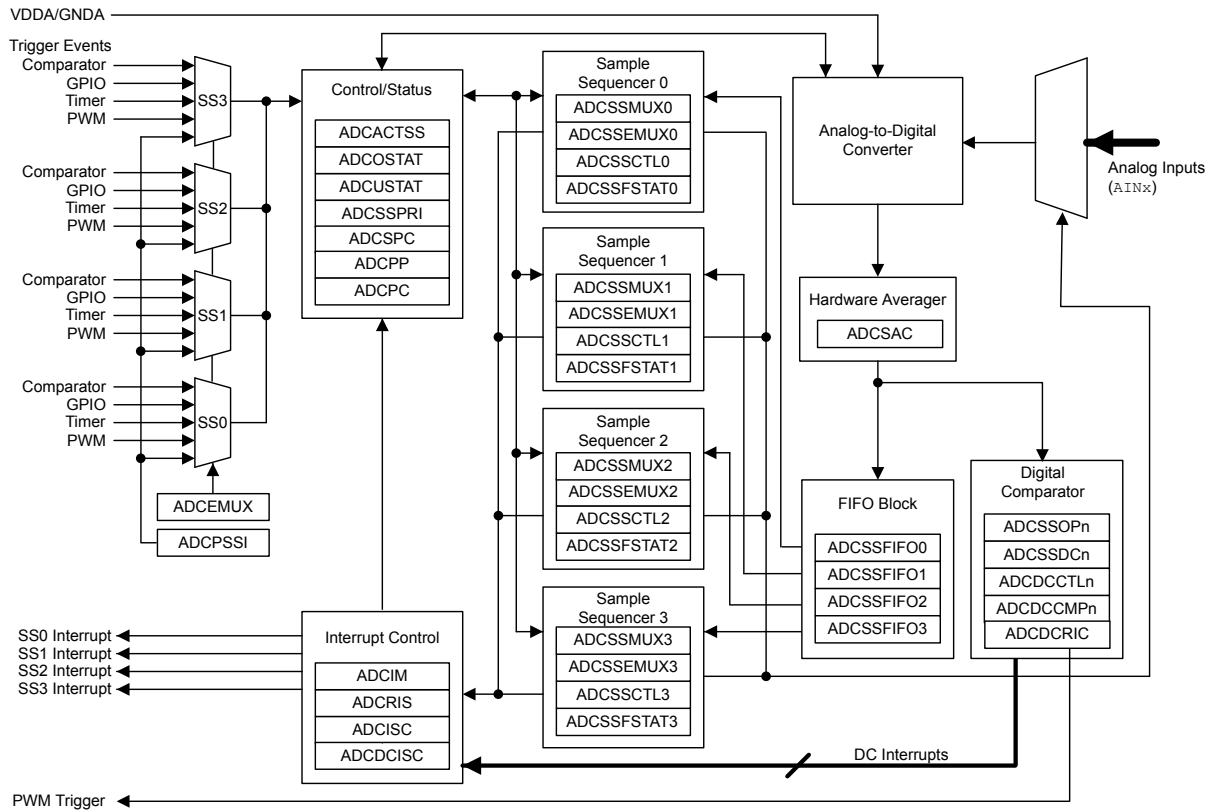

Figure 12-2 on page 774 provides details on the internal configuration of the ADC controls and data registers.

Figure 12-2. ADC Module Block Diagram



12.2 Signal Description

The following table lists the external signals of the ADC module and describes the function of each. The AIN_x signals are analog functions for some GPIO signals. The column in the table below titled "Pin Mux/Pin Assignment" lists the GPIO pin placement for the ADC signals. These signals are configured by clearing the corresponding DEN bit in the **GPIO Digital Enable (GPIODEN)** register and setting the corresponding AMSEL bit in the **GPIO Analog Mode Select (GPIOAMSEL)** register. For more information on configuring GPIOs, see "General-Purpose Input/Outputs (GPIOs)" on page 623.

Table 12-1. ADC Signals (64LQFP)

Pin Name	Pin Number	Pin Mux / Pin Assignment	Pin Type	Buffer Type ^a	Description
AIN0	6	PE3	I	Analog	Analog-to-digital converter input 0.
AIN1	7	PE2	I	Analog	Analog-to-digital converter input 1.
AIN2	8	PE1	I	Analog	Analog-to-digital converter input 2.
AIN3	9	PE0	I	Analog	Analog-to-digital converter input 3.
AIN4	64	PD3	I	Analog	Analog-to-digital converter input 4.
AIN5	63	PD2	I	Analog	Analog-to-digital converter input 5.
AIN6	62	PD1	I	Analog	Analog-to-digital converter input 6.
AIN7	61	PD0	I	Analog	Analog-to-digital converter input 7.
AIN8	60	PE5	I	Analog	Analog-to-digital converter input 8.

Table 12-1. ADC Signals (64LQFP) (continued)

Pin Name	Pin Number	Pin Mux / Pin Assignment	Pin Type	Buffer Type ^a	Description
AIN9	59	PE4	I	Analog	Analog-to-digital converter input 9.
AIN10	58	PB4	I	Analog	Analog-to-digital converter input 10.
AIN11	57	PB5	I	Analog	Analog-to-digital converter input 11.

a. The TTL designation indicates the pin has TTL-compatible voltage levels.

12.3 Functional Description

The Stellaris ADC collects sample data by using a programmable sequence-based approach instead of the traditional single or double-sampling approaches found on many ADC modules. Each *sample sequence* is a fully programmed series of consecutive (back-to-back) samples, allowing the ADC to collect data from multiple input sources without having to be re-configured or serviced by the processor. The programming of each sample in the sample sequence includes parameters such as the input source and mode (differential versus single-ended input), interrupt generation on sample completion, and the indicator for the last sample in the sequence. In addition, the μ DMA can be used to more efficiently move data from the sample sequencers without CPU intervention.

12.3.1 Sample Sequencers

The sampling control and data capture is handled by the sample sequencers. All of the sequencers are identical in implementation except for the number of samples that can be captured and the depth of the FIFO. Table 12-2 on page 775 shows the maximum number of samples that each sequencer can capture and its corresponding FIFO depth. Each sample that is captured is stored in the FIFO. In this implementation, each FIFO entry is a 32-bit word, with the lower 12 bits containing the conversion result.

Table 12-2. Samples and FIFO Depth of Sequencers

Sequencer	Number of Samples	Depth of FIFO
SS3	1	1
SS2	4	4
SS1	4	4
SS0	8	8

For a given sample sequence, each sample is defined by bit fields in the **ADC Sample Sequence Input Multiplexer Select (ADCSSMUXn)** and **ADC Sample Sequence Control (ADCSSCTLn)** registers, where "n" corresponds to the sequence number. The **ADCSSMUXn** fields select the input pin, while the **ADCSSCTLn** fields contain the sample control bits corresponding to parameters such as temperature sensor selection, interrupt enable, end of sequence, and differential input mode. Sample sequencers are enabled by setting the respective **ASENn** bit in the **ADC Active Sample Sequencer (ADCACTSS)** register and should be configured before being enabled. Sampling is then initiated by setting the **SSn** bit in the **ADC Processor Sample Sequence Initiate (ADCPSSI)** register. In addition, sample sequences may be initiated on multiple ADC modules simultaneously using the **GSYNC** and **SYNCWAIT** bits in the **ADCPSSI** register during the configuration of each ADC module. For more information on using these bits, refer to page 815.

When configuring a sample sequence, multiple uses of the same input pin within the same sequence are allowed. In the **ADCSSCTLn** register, the **IE_n** bits can be set for any combination of samples, allowing interrupts to be generated after every sample in the sequence if necessary. Also, the **END** bit can be set at any point within a sample sequence. For example, if Sequencer 0 is used, the **END**

bit can be set in the nibble associated with the fifth sample, allowing Sequencer 0 to complete execution of the sample sequence after the fifth sample.

After a sample sequence completes execution, the result data can be retrieved from the **ADC Sample Sequence Result FIFO (ADCSSFIFO_n)** registers. The FIFOs are simple circular buffers that read a single address to "pop" result data. For software debug purposes, the positions of the FIFO head and tail pointers are visible in the **ADC Sample Sequence FIFO Status (ADCSSFSTAT_n)** registers along with **FULL** and **EMPTY** status flags. If a write is attempted when the FIFO is full, the write does not occur and an overflow condition is indicated. Overflow and underflow conditions are monitored using the **ADCOSTAT** and **ADCUSTAT** registers.

12.3.2 Module Control

Outside of the sample sequencers, the remainder of the control logic is responsible for tasks such as:

- Interrupt generation
- DMA operation
- Sequence prioritization
- Trigger configuration
- Comparator configuration
- External voltage reference
- Sample phase control
- Module clocking

Most of the ADC control logic runs at the ADC clock rate of 16 MHz. The internal ADC divider is configured for 16-MHz operation automatically by hardware when the system **XTAL** is selected with the PLL.

12.3.2.1 Interrupts

The register configurations of the sample sequencers and digital comparators dictate which events generate raw interrupts, but do not have control over whether the interrupt is actually sent to the interrupt controller. The ADC module's interrupt signals are controlled by the state of the **MASK** bits in the **ADC Interrupt Mask (ADCIM)** register. Interrupt status can be viewed at two locations: the **ADC Raw Interrupt Status (ADCRIS)** register, which shows the raw status of the various interrupt signals; and the **ADC Interrupt Status and Clear (ADCISC)** register, which shows active interrupts that are enabled by the **ADCIM** register. Sequencer interrupts are cleared by writing a 1 to the corresponding **IN** bit in **ADCISC**. Digital comparator interrupts are cleared by writing a 1 to the **ADC Digital Comparator Interrupt Status and Clear (ADCDCISC)** register.

12.3.2.2 DMA Operation

DMA may be used to increase efficiency by allowing each sample sequencer to operate independently and transfer data without processor intervention or reconfiguration. The ADC module provides a request signal from each sample sequencer to the associated dedicated channel of the μ DMA controller. The ADC does not support single transfer requests. A burst transfer request is asserted when the interrupt bit for the sample sequence is set (**IE** bit in the **ADCSSCTL_n** register is set).

The arbitration size of the μ DMA transfer must be a power of 2, and the associated IE bits in the **ADCSSCTLn** register must be set. For example, if the μ DMA channel of SS0 has an arbitration size of four, the $IE3$ bit (4th sample) and the $IE7$ bit (8th sample) must be set. Thus the μ DMA request occurs every time 4 samples have been acquired. No other special steps are needed to enable the ADC module for μ DMA operation.

Refer to the “Micro Direct Memory Access (μ DMA)” on page 559 for more details about programming the μ DMA controller.

12.3.2.3 Prioritization

When sampling events (triggers) happen concurrently, they are prioritized for processing by the values in the **ADC Sample Sequencer Priority (ADCSSPRI)** register. Valid priority values are in the range of 0-3, with 0 being the highest priority and 3 being the lowest. Multiple active sample sequencer units with the same priority do not provide consistent results, so software must ensure that all active sample sequencer units have a unique priority value.

12.3.2.4 Sampling Events

Sample triggering for each sample sequencer is defined in the **ADC Event Multiplexer Select (ADCEMUX)** register. Trigger sources include processor (default), analog comparators, an external signal on a GPIO specified by the **GPIO ADC Control (GPIOADCCTL)** register, a GP Timer, a PWM generator, and continuous sampling. The processor triggers sampling by setting the SSx bits in the **ADC Processor Sample Sequence Initiate (ADCPSSI)** register.

Care must be taken when using the continuous sampling trigger. If a sequencer's priority is too high, it is possible to starve other lower priority sequencers. Generally, a sample sequencer using continuous sampling should be set to the lowest priority. Continuous sampling can be used with a digital comparator to cause an interrupt when a particular voltage is seen on an input.

12.3.2.5 Sample Phase Control

The trigger source for ADC0 and ADC1 may be independent or the two ADC modules may operate from the same trigger source and operate on the same or different inputs. If the converters are running at the same sample rate, they may be configured to start the conversions coincidentally or with one of 15 different discrete phases relative to each other. The sample time can be delayed from the standard sampling time in 22.5° increments up to 337.5° using the **ADC Sample Phase Control (ADCSPC)** register. Figure 12-3 on page 777 shows an example of various phase relationships at a 1 Msps rate.

Figure 12-3. ADC Sample Phases

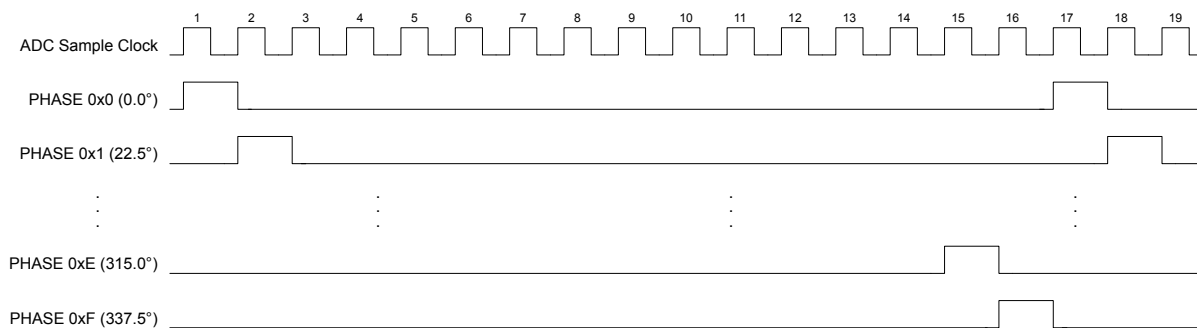

This feature can be used to double the sampling rate of an input. Both ADC module 0 and ADC module 1 can be programmed to sample the same input. ADC module 0 could sample at the standard

position (the *PHASE* field in the **ADCSPC** register is 0x0). ADC module 1 can be configured to sample at 180 (*PHASE* = 0x8). The two modules can be synchronized using the *GSYNC* and *SYNCWAIT* bits in the **ADC Processor Sample Sequence Initiate (ADCPSSI)** register. Software could then combine the results from the two modules to create a sample rate of two million samples/second at 16 MHz as shown in Figure 12-4 on page 778.

Figure 12-4. Doubling the ADC Sample Rate

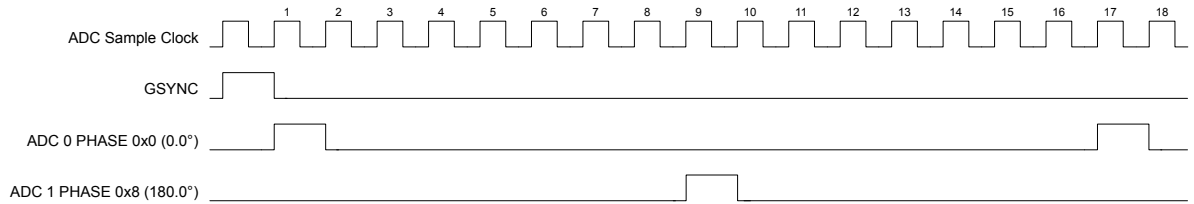

Using the **ADCSPC** register, ADC0 and ADC1 may provide a number of interesting applications:

- Coincident sampling of different signals. The sample sequence steps run coincidentally in both converters.
 - ADC Module 0, **ADCSPC** = 0x0, sampling *A_{IN0}*
 - ADC Module 1, **ADCSPC** = 0x0, sampling *A_{IN1}*
- Skewed sampling of the same signal. The sample sequence steps are 1/2 of an ADC clock (500 μs for a 1Ms/s ADC) out of phase with each other. This configuration doubles the conversion bandwidth of a single input when software combines the results as shown in Figure 12-5 on page 778.
 - ADC Module 0, **ADCSPC** = 0x0, sampling *A_{IN0}*
 - ADC Module 1, **ADCSPC** = 0x8, sampling *A_{IN0}*

Figure 12-5. Skewed Sampling

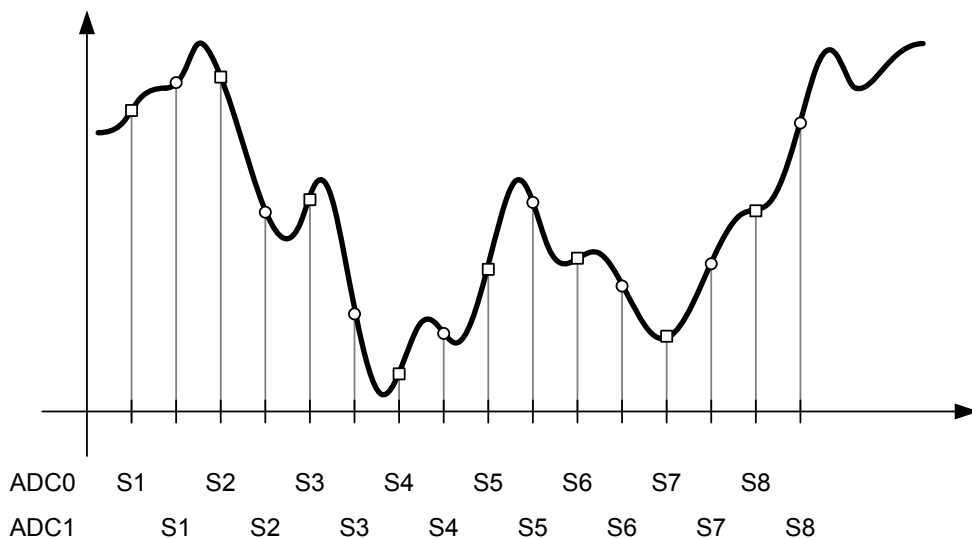

12.3.2.6 Module Clocking

The module is clocked by a 16-MHz clock which can be sourced by a divided version of the PLL output, the PIOSC or an external source connected to MOSC (with the PLL in bypass mode). When the PLL is operating, the ADC clock is derived from the PLL $\div 25$ by default. However, the PIOSC can be used for the module clock using the **ADC Clock Configuration (ADCCC)** register. When the PLL is bypassed, the module clock source clock attached to the MOSC must be 16 MHz unless the PIOSC is used for the clock source. The ADC module can continue to operate in Deep-Sleep mode if the PIOSC is the ADC module clock source.

12.3.3 Hardware Sample Averaging Circuit

Higher precision results can be generated using the hardware averaging circuit, however, the improved results are at the cost of throughput. Up to 64 samples can be accumulated and averaged to form a single data entry in the sequencer FIFO. Throughput is decreased proportionally to the number of samples in the averaging calculation. For example, if the averaging circuit is configured to average 16 samples, the throughput is decreased by a factor of 16.

By default the averaging circuit is off, and all data from the converter passes through to the sequencer FIFO. The averaging hardware is controlled by the **ADC Sample Averaging Control (ADCSAC)** register (see page 817). A single averaging circuit has been implemented, thus all input channels receive the same amount of averaging whether they are single-ended or differential.

Figure 12-6 shows an example in which the **ADCSAC** register is set to 0x2 for 4x hardware oversampling and the **IE1** bit is set for the sample sequence, resulting in an interrupt after the second averaged value is stored in the FIFO.

Figure 12-6. Sample Averaging Example

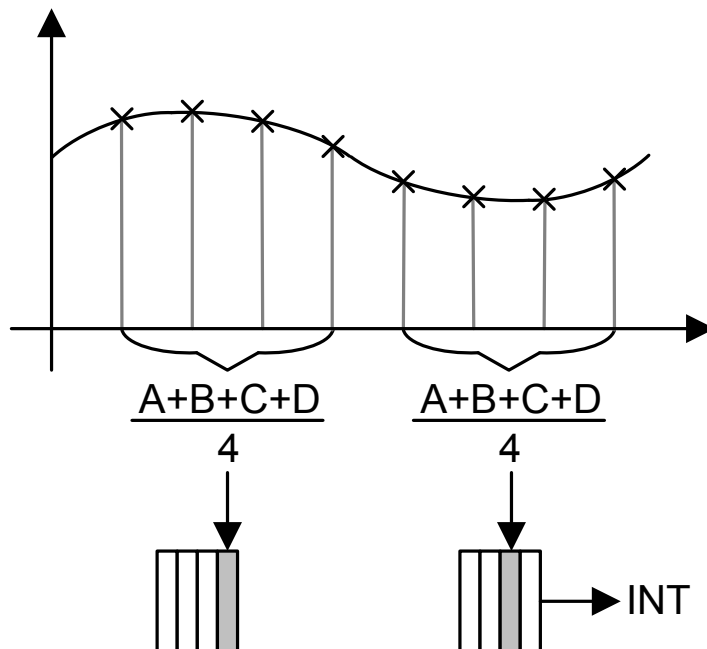

12.3.4 Analog-to-Digital Converter

The Analog-to-Digital Converter (ADC) module uses a Successive Approximation Register (SAR) architecture to deliver a 12-bit, low-power, high-precision conversion value. The successive

approximation uses a switched capacitor array to perform the dual functions of sampling and holding the signal as well as providing the 12-bit DAC operation. The ADC requires a 16-MHz clock. This clock can be a divided version of the PLL output, the PIOSC or a 16-MHz clock source connected to MOSC. The MOSC provides the best results, followed by the PLL divided down, and then the PIOSC. Figure 12-7 shows the ADC input equivalency diagram; for parameter values, see “Analog-to-Digital Converter (ADC)” on page 1335.

Figure 12-7. ADC Input Equivalency Diagram

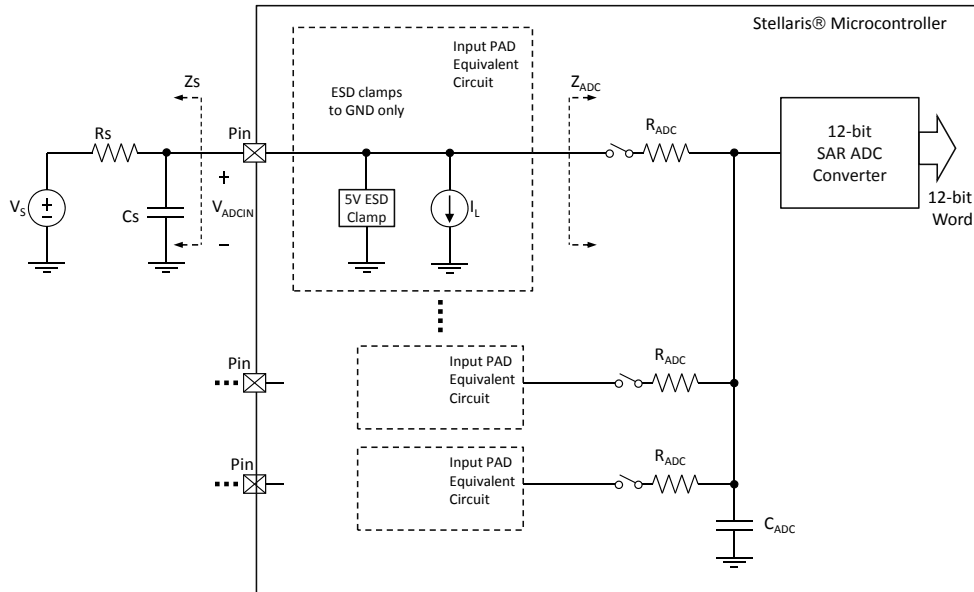

The ADC operates from both the 3.3-V analog and 1.2-V digital power supplies. The ADC clock can be configured to reduce power consumption when ADC conversions are not required (see “System Control” on page 227). The analog inputs are connected to the ADC through specially balanced input paths to minimize the distortion and cross-talk on the inputs. Detailed information on the ADC power supplies and analog inputs can be found in “Analog-to-Digital Converter (ADC)” on page 1335.

12.3.4.1 Voltage Reference

The ADC uses internal signals VREFP and VREFN as references to produce a conversion value from the selected analog input. VREFP is connected to VDDA and VREFN is connected to GNDA, as shown in Figure 12-8.

Figure 12-8. ADC Voltage Reference

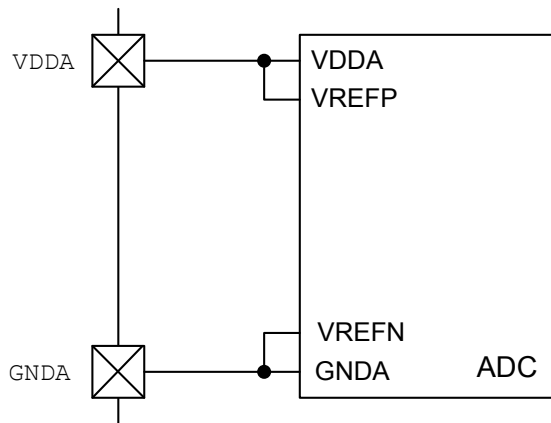

The range of this conversion value is from 0x000 to 0xFFFF. In single-ended-input mode, the 0x000 value corresponds to the voltage level on VREFN; the 0xFFFF value corresponds to the voltage level on VREFP. This configuration results in a resolution that can be calculated using the following equation:

$$\text{mV per ADC code} = (VREFP - VREFN) / 4096$$

While the analog input pads can handle voltages beyond this range, the ADC conversions saturate in under-voltage and over-voltage cases. Analog input voltages above VREFP saturate at 0xFFFF while those below VREFN saturate at 0x000. Figure 12-9 on page 782 shows the ADC conversion function of the analog inputs.

Figure 12-9. ADC Conversion Result

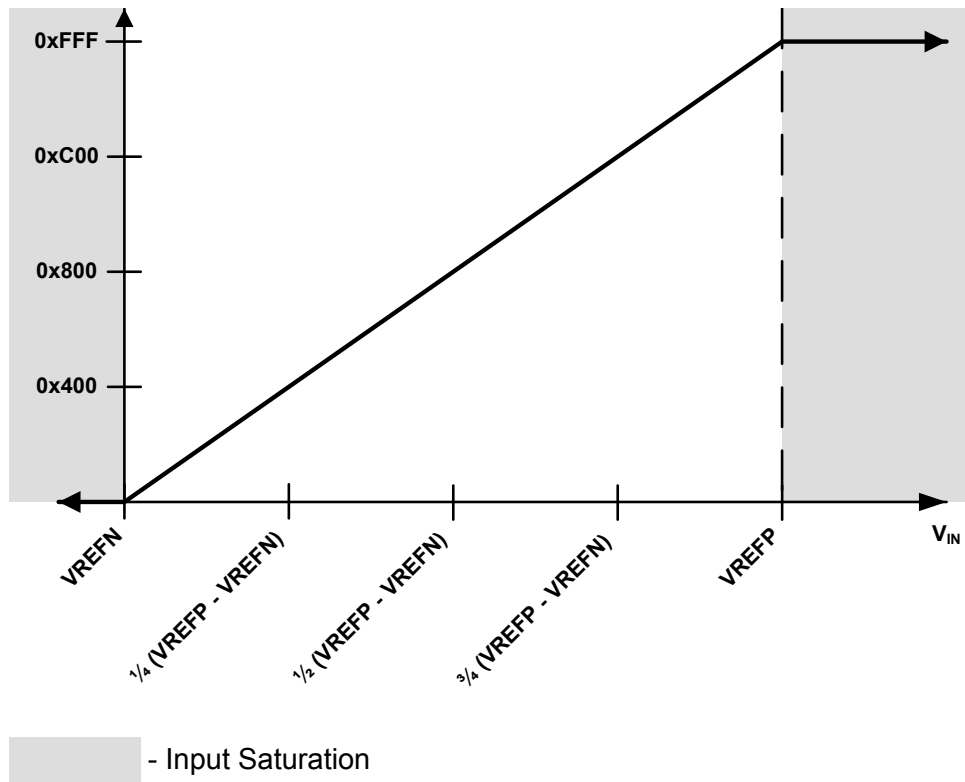

12.3.5 Differential Sampling

In addition to traditional single-ended sampling, the ADC module supports differential sampling of two analog input channels. To enable differential sampling, software must set the D_n bit in the **ADCSSCTL0n** register in a step's configuration nibble.

When a sequence step is configured for differential sampling, the input pair to sample must be configured in the **ADCSSMUXn** register. Differential pair 0 samples analog inputs 0 and 1; differential pair 1 samples analog inputs 2 and 3; and so on (see Table 12-3 on page 782). The ADC does not support other differential pairings such as analog input 0 with analog input 3.

Table 12-3. Differential Sampling Pairs

Differential Pair	Analog Inputs
0	0 and 1
1	2 and 3
2	4 and 5
3	6 and 7
4	8 and 9
5	10 and 11

The voltage sampled in differential mode is the difference between the odd and even channels:

- Input Positive Voltage: $V_{IN+} = V_{IN_EVEN}$ (even channel)
- Input Negative Voltage: $V_{IN-} = V_{IN_ODD}$ (odd channel)

The input differential voltage is defined as: $V_{IN_D} = V_{IN+} - V_{IN-}$, therefore:

- If $V_{IN_D} = 0$, then the conversion result = 0x800
- If $V_{IN_D} > 0$, then the conversion result > 0x800 (range is 0x800–0xFFFF)
- If $V_{IN_D} < 0$, then the conversion result < 0x800 (range is 0–0x800)

When using differential sampling, the following definitions are relevant:

- Input Common Mode Voltage: $V_{IN_{CM}} = (V_{IN+} + V_{IN-}) / 2$
- Reference Positive Voltage: V_{REFP}
- Reference Negative Voltage: V_{REFN}
- Reference Differential Voltage: $V_{REF_D} = V_{REFP} - V_{REFN}$
- Reference Common Mode Voltage: $V_{REF_{CM}} = (V_{REFP} + V_{REFN}) / 2$

The following conditions provide optimal results in differential mode:

- Both V_{IN_EVEN} and V_{IN_ODD} must be in the range of (V_{REFP} to V_{REFN}) for a valid conversion result
- The maximum possible differential input swing, or the maximum differential range, is: $-V_{REF_D}$ to $+V_{REF_D}$, so the maximum peak-to-peak input differential signal is $(+V_{REF_D} - -V_{REF_D}) = 2 * V_{REF_D} = 2 * (V_{REFP} - V_{REFN})$
- In order to take advantage of the maximum possible differential input swing, $V_{IN_{CM}}$ should be very close to $V_{REF_{CM}}$, see Table 24-22 on page 1335.

If $V_{IN_{CM}}$ is not equal to $V_{REF_{CM}}$, the differential input signal may clip at either maximum or minimum voltage, because either single ended input can never be larger than V_{REFP} or smaller than V_{REFN} , and it is not possible to achieve full swing. Thus any difference in common mode between the input voltage and the reference voltage limits the differential dynamic range of the ADC.

Because the maximum peak-to-peak differential signal voltage is $2 * (V_{REFP} - V_{REFN})$, the ADC codes are interpreted as:

$$\text{mV per ADC code} = (2 * (V_{REFP} - V_{REFN})) / 4096$$

Figure 12-10 shows how the differential voltage, ΔV , is represented in ADC codes.

Figure 12-10. Differential Voltage Representation

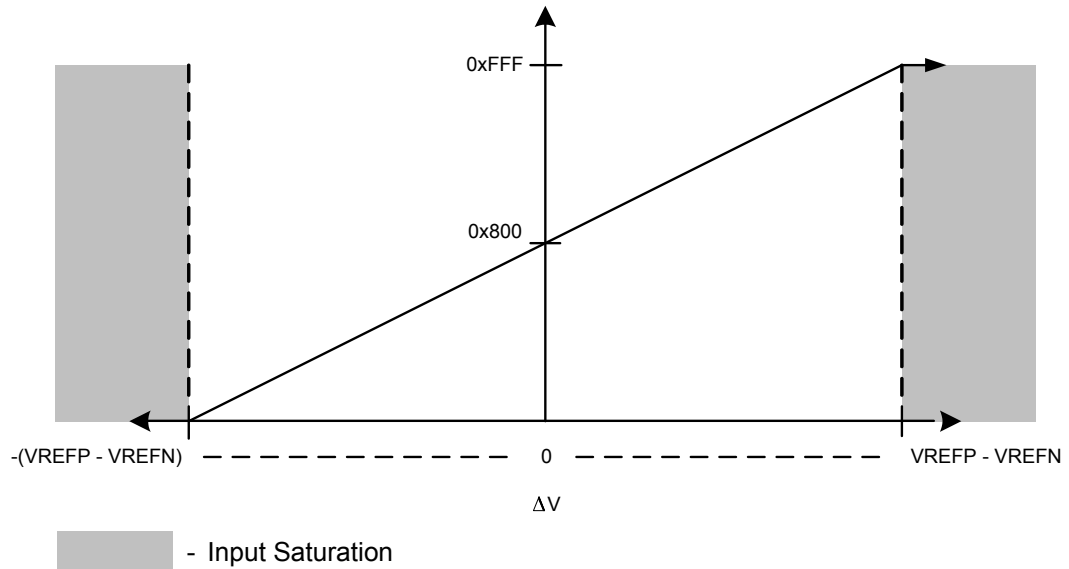

12.3.6 Internal Temperature Sensor

The temperature sensor's primary purpose is to notify the system that the internal temperature is too high or low for reliable operation.

The temperature sensor does not have a separate enable, because it also contains the bandgap reference and must always be enabled. The reference is supplied to other analog modules; not just the ADC.

The internal temperature sensor converts a temperature measurement into a voltage. This voltage value, V_{TSENS} , is given by the following equation (where TEMP is the temperature in °C):

$$V_{TSENS} = 2.7 - ((TEMP + 55) / 75)$$

This relation is shown in Figure 12-11 on page 785.

Figure 12-11. Internal Temperature Sensor Characteristic

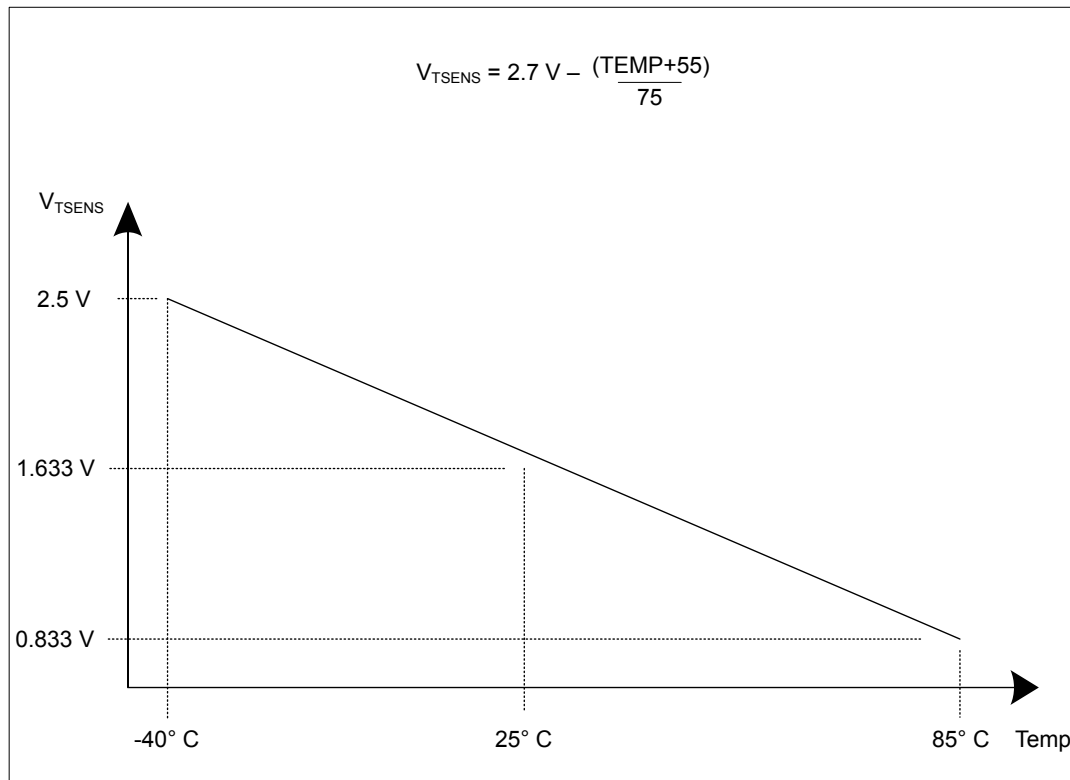

The temperature sensor reading can be sampled in a sample sequence by setting the TS_n bit in the **ADCSCTLn** register. The temperature reading from the temperature sensor can also be given as a function of the ADC value. The following formula calculates temperature (TEMP in °C) based on the ADC reading (ADC_{CODE} , given as an unsigned decimal number from 0 to 4095) and the maximum ADC voltage range ($V_{REFP} - V_{REFN}$):

$$TEMP = 147.5 - ((75 * (V_{REFP} - V_{REFN}) * ADC_{CODE}) / 4096)$$

12.3.7 Digital Comparator Unit

An ADC is commonly used to sample an external signal and to monitor its value to ensure that it remains in a given range. To automate this monitoring procedure and reduce the amount of processor overhead that is required, each module provides eight digital comparators.

Conversions from the ADC that are sent to the digital comparators are compared against the user programmable limits in the **ADC Digital Comparator Range (ADCDCMPn)** registers. The ADC can be configured to generate an interrupt depending on whether the ADC is operating within the low, mid or high-band region configured in the $ADCDCMP_n$ bit fields. The digital comparators four operational modes (Once, Always, Hysteresis Once, Hysteresis Always) can be additionally applied to the interrupt configuration.

12.3.7.1 Output Functions

ADC conversions can either be stored in the ADC Sample Sequence FIFOs or compared using the digital comparator resources as defined by the S_nDCOP bits in the **ADC Sample Sequence n Operation (ADCSOPn)** register. These selected ADC conversions are used by their respective

digital comparator to monitor the external signal. Each comparator has two possible output functions: processor interrupts and triggers.

Each function has its own state machine to track the monitored signal. Even though the interrupt and trigger functions can be enabled individually or both at the same time, the same conversion data is used by each function to determine if the right conditions have been met to assert the associated output.

Interrupts

The digital comparator interrupt function is enabled by setting the `CIE` bit in the **ADC Digital Comparator Control (ADCDCCTLn)** register. This bit enables the interrupt function state machine to start monitoring the incoming ADC conversions. When the appropriate set of conditions is met, and the `DCONSx` bit is set in the **ADCIM** register, an interrupt is sent to the interrupt controller.

Triggers

The digital comparator trigger function is enabled by setting the `CTE` bit in the **ADCDCCTLn** register. This bit enables the trigger function state machine to start monitoring the incoming ADC conversions. When the appropriate set of conditions is met, the corresponding digital comparator trigger to the PWM module is asserted

12.3.7.2 Operational Modes

Four operational modes are provided to support a broad range of applications and multiple possible signaling requirements: Always, Once, Hysteresis Always, and Hysteresis Once. The operational mode is selected using the `CIM` or `CTM` field in the **ADCDCCTLn** register.

Always Mode

In the Always operational mode, the associated interrupt or trigger is asserted whenever the ADC conversion value meets its comparison criteria. The result is a string of assertions on the interrupt or trigger while the conversions are within the appropriate range.

Once Mode

In the Once operational mode, the associated interrupt or trigger is asserted whenever the ADC conversion value meets its comparison criteria, and the previous ADC conversion value did not. The result is a single assertion of the interrupt or trigger when the conversions are within the appropriate range.

Hysteresis-Always Mode

The Hysteresis-Always operational mode can only be used in conjunction with the low-band or high-band regions because the mid-band region must be crossed and the opposite region entered to clear the hysteresis condition. In the Hysteresis-Always mode, the associated interrupt or trigger is asserted in the following cases: 1) the ADC conversion value meets its comparison criteria or 2) a previous ADC conversion value has met the comparison criteria, and the hysteresis condition has not been cleared by entering the opposite region. The result is a string of assertions on the interrupt or trigger that continue until the opposite region is entered.

Hysteresis-Once Mode

The Hysteresis-Once operational mode can only be used in conjunction with the low-band or high-band regions because the mid-band region must be crossed and the opposite region entered to clear the hysteresis condition. In the Hysteresis-Once mode, the associated interrupt or trigger is asserted only when the ADC conversion value meets its comparison criteria, the hysteresis

condition is clear, and the previous ADC conversion did not meet the comparison criteria. The result is a single assertion on the interrupt or trigger.

12.3.7.3 Function Ranges

The two comparison values, `COMP0` and `COMP1`, in the **ADC Digital Comparator Range (ADCDCMPn)** register effectively break the conversion area into three distinct regions. These regions are referred to as the low-band (less than or equal to `COMP0`), mid-band (greater than `COMP0` but less than or equal to `COMP1`), and high-band (greater than `COMP1`) regions. `COMP0` and `COMP1` may be programmed to the same value, effectively creating two regions, but `COMP1` must always be greater than or equal to the value of `COMP0`. A `COMP1` value that is less than `COMP0` generates unpredictable results.

Low-Band Operation

To operate in the low-band region, either the `CIC` field or the `CTC` field in the **ADCDCCTLn** register must be programmed to `0x0`. This setting causes interrupts or triggers to be generated in the low-band region as defined by the programmed operational mode. An example of the state of the interrupt/trigger signal in the low-band region for each of the operational modes is shown in Figure 12-12 on page 787. Note that a "0" in a column following the operational mode name (Always, Once, Hysteresis Always, and Hysteresis Once) indicates that the interrupt or trigger signal is de-asserted and a "1" indicates that the signal is asserted.

Figure 12-12. Low-Band Operation (`CIC=0x0` and/or `CTC=0x0`)

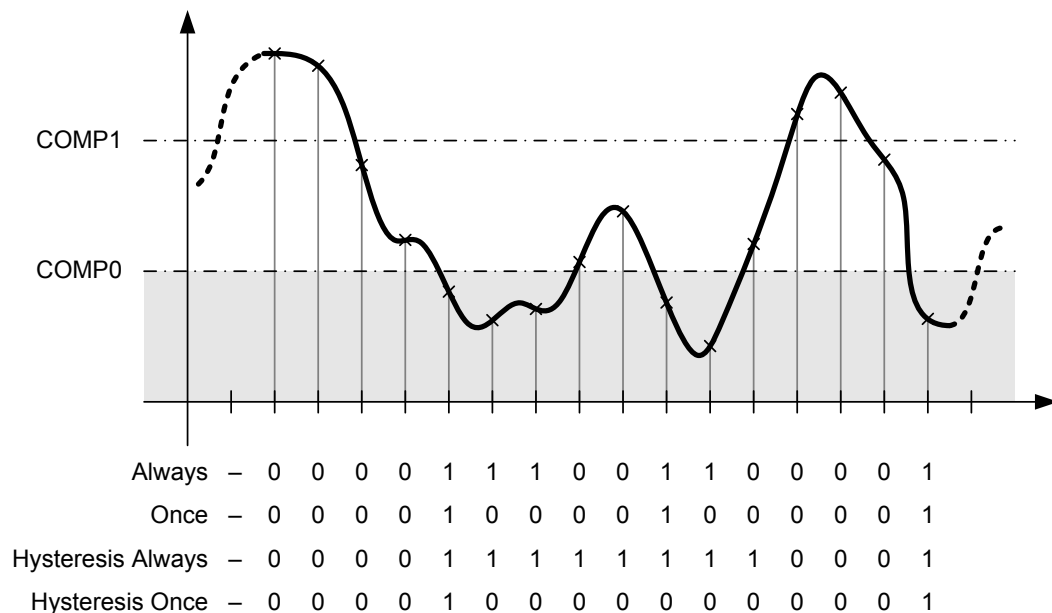

Mid-Band Operation

To operate in the mid-band region, either the `CIC` field or the `CTC` field in the **ADCDCCTLn** register must be programmed to `0x1`. This setting causes interrupts or triggers to be generated in the mid-band region according the operation mode. Only the Always and Once operational modes are available

in the mid-band region. An example of the state of the interrupt/trigger signal in the mid-band region for each of the allowed operational modes is shown in Figure 12-13 on page 788. Note that a "0" in a column following the operational mode name (Always or Once) indicates that the interrupt or trigger signal is de-asserted and a "1" indicates that the signal is asserted.

Figure 12-13. Mid-Band Operation (CIC=0x1 and/or CTC=0x1)

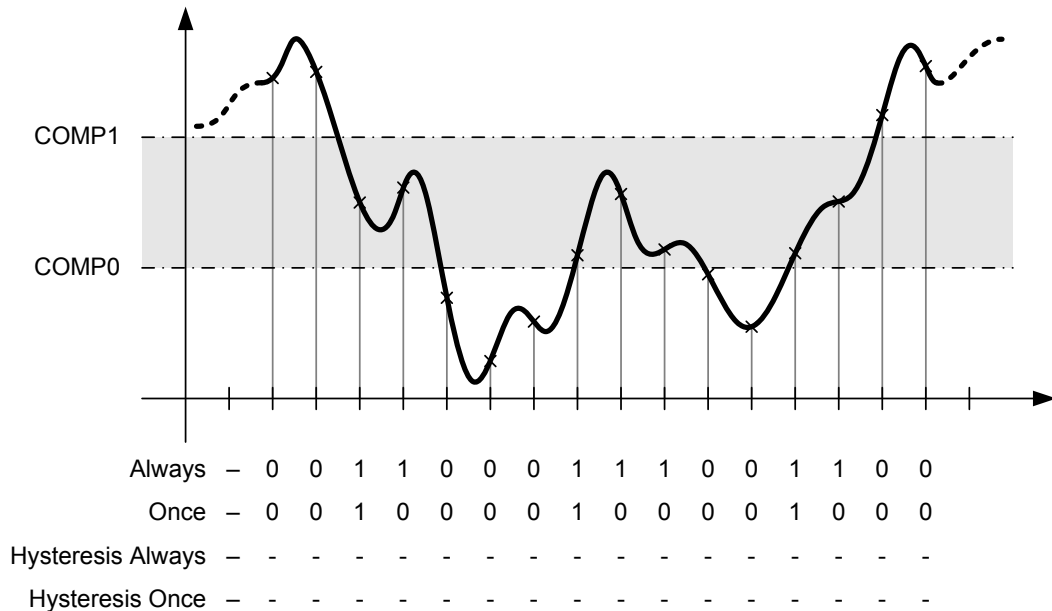

High-Band Operation

To operate in the high-band region, either the CIC field or the CTC field in the ADCDCCTLn register must be programmed to 0x3. This setting causes interrupts or triggers to be generated in the high-band region according the operation mode. An example of the state of the interrupt/trigger signal in the high-band region for each of the allowed operational modes is shown in Figure 12-14 on page 789. Note that a "0" in a column following the operational mode name (Always, Once, Hysteresis Always, and Hysteresis Once) indicates that the interrupt or trigger signal is de-asserted and a "1" indicates that the signal is asserted.

Figure 12-14. High-Band Operation (CIC=0x3 and/or CTC=0x3)

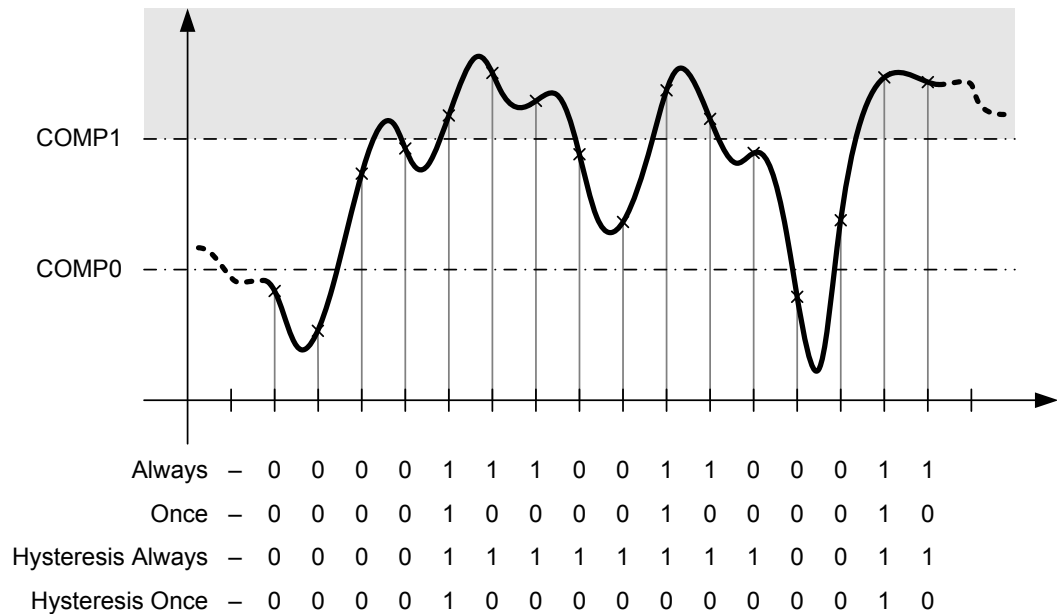

12.4 Initialization and Configuration

In order for the ADC module to be used, the PLL must be enabled and programmed to a supported crystal frequency in the **RCC** register (see page 249). Using unsupported frequencies can cause faulty operation in the ADC module.

12.4.1 Module Initialization

Initialization of the ADC module is a simple process with very few steps: enabling the clock to the ADC, disabling the analog isolation circuit associated with all inputs that are to be used, and reconfiguring the sample sequencer priorities (if needed).

The initialization sequence for the ADC is as follows:

1. Enable the ADC clock using the **RCGCADC** register (see page 330).
2. Enable the clock to the appropriate GPIO modules via the **RCGCGPIO** register (see page 319). To find out which GPIO ports to enable, refer to “Signal Description” on page 774.
3. Set the GPIO **AFSEL** bits for the ADC input pins (see page 644). To determine which GPIOs to configure, see Table 22-4 on page 1307.
4. Configure the **AIN_x** signals to be analog inputs by clearing the corresponding **DEN** bit in the **GPIO Digital Enable (GPIODEN)** register (see page 655).
5. Disable the analog isolation circuit for all ADC input pins that are to be used by writing a 1 to the appropriate bits of the **GPIOAMSEL** register (see page 660) in the associated GPIO block.

6. If required by the application, reconfigure the sample sequencer priorities in the **ADCSSPRI** register. The default configuration has Sample Sequencer 0 with the highest priority and Sample Sequencer 3 as the lowest priority.

12.4.2 Sample Sequencer Configuration

Configuration of the sample sequencers is slightly more complex than the module initialization because each sample sequencer is completely programmable.

The configuration for each sample sequencer should be as follows:

1. Ensure that the sample sequencer is disabled by clearing the corresponding **ASEN_n** bit in the **ADCACTSS** register. Programming of the sample sequencers is allowed without having them enabled. Disabling the sequencer during programming prevents erroneous execution if a trigger event were to occur during the configuration process.
2. Configure the trigger event for the sample sequencer in the **ADCEMUX** register.
3. For each sample in the sample sequence, configure the corresponding input source in the **ADCSSMUX_n** register.
4. For each sample in the sample sequence, configure the sample control bits in the corresponding nibble in the **ADCSSCTL_n** register. When programming the last nibble, ensure that the **END** bit is set. Failure to set the **END** bit causes unpredictable behavior.
5. If interrupts are to be used, set the corresponding **MASK** bit in the **ADCIM** register.
6. Enable the sample sequencer logic by setting the corresponding **ASEN_n** bit in the **ADCACTSS** register.

12.5 Register Map

Table 12-4 on page 790 lists the ADC registers. The offset listed is a hexadecimal increment to the register's address, relative to that ADC module's base address of:

- ADC0: 0x4003.8000
- ADC1: 0x4003.9000

Note that the ADC module clock must be enabled before the registers can be programmed (see page 330). There must be a delay of 3 system clocks after the ADC module clock is enabled before any ADC module registers are accessed.

Table 12-4. ADC Register Map

Offset	Name	Type	Reset	Description	See page
0x000	ADCACTSS	R/W	0x0000.0000	ADC Active Sample Sequencer	793
0x004	ADCRIS	RO	0x0000.0000	ADC Raw Interrupt Status	794
0x008	ADCIM	R/W	0x0000.0000	ADC Interrupt Mask	796
0x00C	ADCISC	R/W1C	0x0000.0000	ADC Interrupt Status and Clear	798
0x010	ADCOSTAT	R/W1C	0x0000.0000	ADC Overflow Status	801
0x014	ADCEMUX	R/W	0x0000.0000	ADC Event Multiplexer Select	803

Table 12-4. ADC Register Map (continued)

Offset	Name	Type	Reset	Description	See page
0x018	ADCUSTAT	R/W1C	0x0000.0000	ADC Underflow Status	808
0x01C	ADCTSSEL	R/W	0x0000.0000	ADC Trigger Source Select	809
0x020	ADCSSPRI	R/W	0x0000.3210	ADC Sample Sequencer Priority	811
0x024	ADCSPC	R/W	0x0000.0000	ADC Sample Phase Control	813
0x028	ADCPSSI	R/W	-	ADC Processor Sample Sequence Initiate	815
0x030	ADCSAC	R/W	0x0000.0000	ADC Sample Averaging Control	817
0x034	ADCDCISC	R/W1C	0x0000.0000	ADC Digital Comparator Interrupt Status and Clear	818
0x040	ADCSSMUX0	R/W	0x0000.0000	ADC Sample Sequence Input Multiplexer Select 0	820
0x044	ADCSSCTL0	R/W	0x0000.0000	ADC Sample Sequence Control 0	822
0x048	ADCSSFIFO0	RO	-	ADC Sample Sequence Result FIFO 0	825
0x04C	ADCSSFSTAT0	RO	0x0000.0100	ADC Sample Sequence FIFO 0 Status	826
0x050	ADCSSOP0	R/W	0x0000.0000	ADC Sample Sequence 0 Operation	828
0x054	ADCSSDC0	R/W	0x0000.0000	ADC Sample Sequence 0 Digital Comparator Select	830
0x060	ADCSSMUX1	R/W	0x0000.0000	ADC Sample Sequence Input Multiplexer Select 1	832
0x064	ADCSSCTL1	R/W	0x0000.0000	ADC Sample Sequence Control 1	833
0x068	ADCSSFIFO1	RO	-	ADC Sample Sequence Result FIFO 1	825
0x06C	ADCSSFSTAT1	RO	0x0000.0100	ADC Sample Sequence FIFO 1 Status	826
0x070	ADCSSOP1	R/W	0x0000.0000	ADC Sample Sequence 1 Operation	835
0x074	ADCSSDC1	R/W	0x0000.0000	ADC Sample Sequence 1 Digital Comparator Select	836
0x080	ADCSSMUX2	R/W	0x0000.0000	ADC Sample Sequence Input Multiplexer Select 2	832
0x084	ADCSSCTL2	R/W	0x0000.0000	ADC Sample Sequence Control 2	833
0x088	ADCSSFIFO2	RO	-	ADC Sample Sequence Result FIFO 2	825
0x08C	ADCSSFSTAT2	RO	0x0000.0100	ADC Sample Sequence FIFO 2 Status	826
0x090	ADCSSOP2	R/W	0x0000.0000	ADC Sample Sequence 2 Operation	835
0x094	ADCSSDC2	R/W	0x0000.0000	ADC Sample Sequence 2 Digital Comparator Select	836
0x0A0	ADCSSMUX3	R/W	0x0000.0000	ADC Sample Sequence Input Multiplexer Select 3	838
0x0A4	ADCSSCTL3	R/W	0x0000.0000	ADC Sample Sequence Control 3	839
0x0A8	ADCSSFIFO3	RO	-	ADC Sample Sequence Result FIFO 3	825
0x0AC	ADCSSFSTAT3	RO	0x0000.0100	ADC Sample Sequence FIFO 3 Status	826
0x0B0	ADCSSOP3	R/W	0x0000.0000	ADC Sample Sequence 3 Operation	840
0x0B4	ADCSSDC3	R/W	0x0000.0000	ADC Sample Sequence 3 Digital Comparator Select	841
0xD00	ADCDCRIC	WO	0x0000.0000	ADC Digital Comparator Reset Initial Conditions	842

Table 12-4. ADC Register Map (continued)

Offset	Name	Type	Reset	Description	See page
0xE00	ADDCDCCTL0	R/W	0x0000.0000	ADC Digital Comparator Control 0	847
0xE04	ADDCDCCTL1	R/W	0x0000.0000	ADC Digital Comparator Control 1	847
0xE08	ADDCDCCTL2	R/W	0x0000.0000	ADC Digital Comparator Control 2	847
0xE0C	ADDCDCCTL3	R/W	0x0000.0000	ADC Digital Comparator Control 3	847
0xE10	ADDCDCCTL4	R/W	0x0000.0000	ADC Digital Comparator Control 4	847
0xE14	ADDCDCCTL5	R/W	0x0000.0000	ADC Digital Comparator Control 5	847
0xE18	ADDCDCCTL6	R/W	0x0000.0000	ADC Digital Comparator Control 6	847
0xE1C	ADDCDCCTL7	R/W	0x0000.0000	ADC Digital Comparator Control 7	847
0xE40	ADCDCCMP0	R/W	0x0000.0000	ADC Digital Comparator Range 0	850
0xE44	ADCDCCMP1	R/W	0x0000.0000	ADC Digital Comparator Range 1	850
0xE48	ADCDCCMP2	R/W	0x0000.0000	ADC Digital Comparator Range 2	850
0xE4C	ADCDCCMP3	R/W	0x0000.0000	ADC Digital Comparator Range 3	850
0xE50	ADCDCCMP4	R/W	0x0000.0000	ADC Digital Comparator Range 4	850
0xE54	ADCDCCMP5	R/W	0x0000.0000	ADC Digital Comparator Range 5	850
0xE58	ADCDCCMP6	R/W	0x0000.0000	ADC Digital Comparator Range 6	850
0xE5C	ADCDCCMP7	R/W	0x0000.0000	ADC Digital Comparator Range 7	850
0xFC0	ADCPP	RO	0x00B0.20C7	ADC Peripheral Properties	851
0xFC4	ADCPC	R/W	0x0000.0007	ADC Peripheral Configuration	853
0xFC8	ADCCC	R/W	0x0000.0000	ADC Clock Configuration	854

12.6 Register Descriptions

The remainder of this section lists and describes the ADC registers, in numerical order by address offset.

Register 1: ADC Active Sample Sequencer (ADCACTSS), offset 0x000

This register controls the activation of the sample sequencers. Each sample sequencer can be enabled or disabled independently.

ADC Active Sample Sequencer (ADCACTSS)

ADC0 base: 0x4003.8000

ADC1 base: 0x4003.9000

Offset 0x000

Type R/W, reset 0x0000.0000

	31	30	29	28	27	26	25	24	23	22	21	20	19	18	17	16	
	reserved																
Type	RO	RO	RO	RO	RO	RO	RO	RO	RO	RO	RO	RO	RO	RO	RO	RO	
Reset	0	0	0	0	0	0	0	0	0	0	0	0	0	0	0	0	
	15	14	13	12	11	10	9	8	7	6	5	4	3	2	1	0	
	reserved												ASEN3	ASEN2	ASEN1	ASEN0	
Type	RO	RO	RO	RO	RO	RO	RO	RO	RO	RO	RO	RO	RO	R/W	R/W	R/W	R/W
Reset	0	0	0	0	0	0	0	0	0	0	0	0	0	0	0	0	0

Bit/Field	Name	Type	Reset	Description
31:4	reserved	RO	0x0000.000	Software should not rely on the value of a reserved bit. To provide compatibility with future products, the value of a reserved bit should be preserved across a read-modify-write operation.
3	ASEN3	R/W	0	ADC SS3 Enable Value Description 1 Sample Sequencer 3 is enabled. 0 Sample Sequencer 3 is disabled.
2	ASEN2	R/W	0	ADC SS2 Enable Value Description 1 Sample Sequencer 2 is enabled. 0 Sample Sequencer 2 is disabled.
1	ASEN1	R/W	0	ADC SS1 Enable Value Description 1 Sample Sequencer 1 is enabled. 0 Sample Sequencer 1 is disabled.
0	ASEN0	R/W	0	ADC SS0 Enable Value Description 1 Sample Sequencer 0 is enabled. 0 Sample Sequencer 0 is disabled.

Register 2: ADC Raw Interrupt Status (ADCRIS), offset 0x004

This register shows the status of the raw interrupt signal of each sample sequencer. These bits may be polled by software to look for interrupt conditions without sending the interrupts to the interrupt controller.

ADC Raw Interrupt Status (ADCRIS)

ADC0 base: 0x4003.8000
 ADC1 base: 0x4003.9000
 Offset 0x004
 Type RO, reset 0x0000.0000

	31	30	29	28	27	26	25	24	23	22	21	20	19	18	17	16
	reserved															INRDC
Type	RO	RO	RO	RO	RO	RO	RO	RO	RO	RO	RO	RO	RO	RO	RO	RO
Reset	0	0	0	0	0	0	0	0	0	0	0	0	0	0	0	0
	15	14	13	12	11	10	9	8	7	6	5	4	3	2	1	0
	reserved												INR3	INR2	INR1	INR0
Type	RO	RO	RO	RO	RO	RO	RO	RO	RO	RO	RO	RO	RO	RO	RO	RO
Reset	0	0	0	0	0	0	0	0	0	0	0	0	0	0	0	0

Bit/Field	Name	Type	Reset	Description
31:17	reserved	RO	0x000	Software should not rely on the value of a reserved bit. To provide compatibility with future products, the value of a reserved bit should be preserved across a read-modify-write operation.
16	INRDC	RO	0	Digital Comparator Raw Interrupt Status Value Description 1 At least one bit in the ADCDCISC register is set, meaning that a digital comparator interrupt has occurred. 0 All bits in the ADCDCISC register are clear.
15:4	reserved	RO	0	Software should not rely on the value of a reserved bit. To provide compatibility with future products, the value of a reserved bit should be preserved across a read-modify-write operation.
3	INR3	RO	0	SS3 Raw Interrupt Status Value Description 1 A sample has completed conversion and the respective ADCSSCTL3 IEn bit is set, enabling a raw interrupt. 0 An interrupt has not occurred. This bit is cleared by writing a 1 to the IN3 bit in the ADCISC register.
2	INR2	RO	0	SS2 Raw Interrupt Status Value Description 1 A sample has completed conversion and the respective ADCSSCTL2 IEn bit is set, enabling a raw interrupt. 0 An interrupt has not occurred. This bit is cleared by writing a 1 to the IN2 bit in the ADCISC register.

Bit/Field	Name	Type	Reset	Description
1	INR1	RO	0	<p>SS1 Raw Interrupt Status</p> <p>Value Description</p> <p>1 A sample has completed conversion and the respective ADCSSCTL1 I_{En} bit is set, enabling a raw interrupt.</p> <p>0 An interrupt has not occurred.</p> <p>This bit is cleared by writing a 1 to the $IN1$ bit in the ADCISC register.</p>
0	INR0	RO	0	<p>SS0 Raw Interrupt Status</p> <p>Value Description</p> <p>1 A sample has completed conversion and the respective ADCSSCTL0 I_{En} bit is set, enabling a raw interrupt.</p> <p>0 An interrupt has not occurred.</p> <p>This bit is cleared by writing a 1 to the $IN0$ bit in the ADCISC register.</p>

Register 3: ADC Interrupt Mask (ADCIM), offset 0x008

This register controls whether the sample sequencer and digital comparator raw interrupt signals are sent to the interrupt controller. Each raw interrupt signal can be masked independently. Only a single DCONSS_n bit should be set at any given time. Setting more than one of these bits results in the INRDC bit from the ADCRIS register being masked, and no interrupt is generated on any of the sample sequencer interrupt lines.

ADC Interrupt Mask (ADCIM)

ADC0 base: 0x4003.8000
 ADC1 base: 0x4003.9000
 Offset 0x008
 Type R/W, reset 0x0000.0000

	31	30	29	28	27	26	25	24	23	22	21	20	19	18	17	16
	reserved												DCONSS3	DCONSS2	DCONSS1	DCONSS0
Type	RO	RO	RO	RO	RO	RO	RO	RO	RO	RO	RO	RO	R/W	R/W	R/W	R/W
Reset	0	0	0	0	0	0	0	0	0	0	0	0	0	0	0	0
	15	14	13	12	11	10	9	8	7	6	5	4	3	2	1	0
	reserved												MASK3	MASK2	MASK1	MASK0
Type	RO	RO	RO	RO	RO	RO	RO	RO	RO	RO	RO	RO	R/W	R/W	R/W	R/W
Reset	0	0	0	0	0	0	0	0	0	0	0	0	0	0	0	0

Bit/Field	Name	Type	Reset	Description
31:20	reserved	RO	0x000	Software should not rely on the value of a reserved bit. To provide compatibility with future products, the value of a reserved bit should be preserved across a read-modify-write operation.
19	DCONSS3	R/W	0	Digital Comparator Interrupt on SS3 Value Description 1 The raw interrupt signal from the digital comparators (INRDC bit in the ADCRIS register) is sent to the interrupt controller on the SS3 interrupt line. 0 The status of the digital comparators does not affect the SS3 interrupt status.
18	DCONSS2	R/W	0	Digital Comparator Interrupt on SS2 Value Description 1 The raw interrupt signal from the digital comparators (INRDC bit in the ADCRIS register) is sent to the interrupt controller on the SS2 interrupt line. 0 The status of the digital comparators does not affect the SS2 interrupt status.
17	DCONSS1	R/W	0	Digital Comparator Interrupt on SS1 Value Description 1 The raw interrupt signal from the digital comparators (INRDC bit in the ADCRIS register) is sent to the interrupt controller on the SS1 interrupt line. 0 The status of the digital comparators does not affect the SS1 interrupt status.

Bit/Field	Name	Type	Reset	Description
16	DCONSS0	R/W	0	Digital Comparator Interrupt on SS0 Value Description 1 The raw interrupt signal from the digital comparators (<i>INRDC</i> bit in the ADCRIS register) is sent to the interrupt controller on the SS0 interrupt line. 0 The status of the digital comparators does not affect the SS0 interrupt status.
15:4	reserved	RO	0	Software should not rely on the value of a reserved bit. To provide compatibility with future products, the value of a reserved bit should be preserved across a read-modify-write operation.
3	MASK3	R/W	0	SS3 Interrupt Mask Value Description 1 The raw interrupt signal from Sample Sequencer 3 (ADCRIS register <i>INR3</i> bit) is sent to the interrupt controller. 0 The status of Sample Sequencer 3 does not affect the SS3 interrupt status.
2	MASK2	R/W	0	SS2 Interrupt Mask Value Description 1 The raw interrupt signal from Sample Sequencer 2 (ADCRIS register <i>INR2</i> bit) is sent to the interrupt controller. 0 The status of Sample Sequencer 2 does not affect the SS2 interrupt status.
1	MASK1	R/W	0	SS1 Interrupt Mask Value Description 1 The raw interrupt signal from Sample Sequencer 1 (ADCRIS register <i>INR1</i> bit) is sent to the interrupt controller. 0 The status of Sample Sequencer 1 does not affect the SS1 interrupt status.
0	MASK0	R/W	0	SS0 Interrupt Mask Value Description 1 The raw interrupt signal from Sample Sequencer 0 (ADCRIS register <i>INR0</i> bit) is sent to the interrupt controller. 0 The status of Sample Sequencer 0 does not affect the SS0 interrupt status.

Register 4: ADC Interrupt Status and Clear (ADCISC), offset 0x00C

This register provides the mechanism for clearing sample sequencer interrupt conditions and shows the status of interrupts generated by the sample sequencers and the digital comparators which have been sent to the interrupt controller. When read, each bit field is the logical AND of the respective **INR** and **MASK** bits. Sample sequencer interrupts are cleared by writing a 1 to the corresponding bit position. Digital comparator interrupts are cleared by writing a 1 to the appropriate bits in the **ADCDCISC** register. If software is polling the **ADCRIS** instead of generating interrupts, the sample sequence **INR_n** bits are still cleared via the **ADCISC** register, even if the **IN_n** bit is not set.

ADC Interrupt Status and Clear (ADCISC)

ADC0 base: 0x4003.8000
 ADC1 base: 0x4003.9000
 Offset 0x00C
 Type R/W1C, reset 0x0000.0000

	31	30	29	28	27	26	25	24	23	22	21	20	19	18	17	16
	reserved												DCINSS3	DCINSS2	DCINSS1	DCINSS0
Type	RO	RO	RO	RO	RO	RO	RO	RO	RO	RO	RO	RO	RO	RO	RO	RO
Reset	0	0	0	0	0	0	0	0	0	0	0	0	0	0	0	0
	15	14	13	12	11	10	9	8	7	6	5	4	3	2	1	0
	reserved												IN3	IN2	IN1	IN0
Type	RO	RO	RO	RO	RO	RO	RO	RO	RO	RO	RO	RO	R/W1C	R/W1C	R/W1C	R/W1C
Reset	0	0	0	0	0	0	0	0	0	0	0	0	0	0	0	0

Bit/Field	Name	Type	Reset	Description
31:20	reserved	RO	0x000	Software should not rely on the value of a reserved bit. To provide compatibility with future products, the value of a reserved bit should be preserved across a read-modify-write operation.
19	DCINSS3	RO	0	Digital Comparator Interrupt Status on SS3 Value Description 1 Both the INRDC bit in the ADCRIS register and the DCONSS3 bit in the ADCIM register are set, providing a level-based interrupt to the interrupt controller. 0 No interrupt has occurred or the interrupt is masked. This bit is cleared by writing a 1 to it. Clearing this bit also clears the INRDC bit in the ADCRIS register.
18	DCINSS2	RO	0	Digital Comparator Interrupt Status on SS2 Value Description 1 Both the INRDC bit in the ADCRIS register and the DCONSS2 bit in the ADCIM register are set, providing a level-based interrupt to the interrupt controller. 0 No interrupt has occurred or the interrupt is masked. This bit is cleared by writing a 1 to it. Clearing this bit also clears the INRDC bit in the ADCRIS register.

Bit/Field	Name	Type	Reset	Description
17	DCINSS1	RO	0	<p>Digital Comparator Interrupt Status on SS1</p> <p>Value Description</p> <p>1 Both the <code>INRDC</code> bit in the ADCRIS register and the <code>DCONSS1</code> bit in the ADCIM register are set, providing a level-based interrupt to the interrupt controller.</p> <p>0 No interrupt has occurred or the interrupt is masked.</p> <p>This bit is cleared by writing a 1 to it. Clearing this bit also clears the <code>INRDC</code> bit in the ADCRIS register.</p>
16	DCINSS0	RO	0	<p>Digital Comparator Interrupt Status on SS0</p> <p>Value Description</p> <p>1 Both the <code>INRDC</code> bit in the ADCRIS register and the <code>DCONSS0</code> bit in the ADCIM register are set, providing a level-based interrupt to the interrupt controller.</p> <p>0 No interrupt has occurred or the interrupt is masked.</p> <p>This bit is cleared by writing a 1 to it. Clearing this bit also clears the <code>INRDC</code> bit in the ADCRIS register.</p>
15:4	reserved	RO	0	<p>Software should not rely on the value of a reserved bit. To provide compatibility with future products, the value of a reserved bit should be preserved across a read-modify-write operation.</p>
3	IN3	R/W1C	0	<p>SS3 Interrupt Status and Clear</p> <p>Value Description</p> <p>1 Both the <code>INR3</code> bit in the ADCRIS register and the <code>MASK3</code> bit in the ADCIM register are set, providing a level-based interrupt to the interrupt controller.</p> <p>0 No interrupt has occurred or the interrupt is masked.</p> <p>This bit is cleared by writing a 1. Clearing this bit also clears the <code>INR3</code> bit in the ADCRIS register.</p>
2	IN2	R/W1C	0	<p>SS2 Interrupt Status and Clear</p> <p>Value Description</p> <p>1 Both the <code>INR2</code> bit in the ADCRIS register and the <code>MASK2</code> bit in the ADCIM register are set, providing a level-based interrupt to the interrupt controller.</p> <p>0 No interrupt has occurred or the interrupt is masked.</p> <p>This bit is cleared by writing a 1. Clearing this bit also clears the <code>INR2</code> bit in the ADCRIS register.</p>

Bit/Field	Name	Type	Reset	Description
1	IN1	R/W1C	0	<p>SS1 Interrupt Status and Clear</p> <p>Value Description</p> <p>1 Both the <code>INR1</code> bit in the ADCRIS register and the <code>MASK1</code> bit in the ADCIM register are set, providing a level-based interrupt to the interrupt controller.</p> <p>0 No interrupt has occurred or the interrupt is masked.</p> <p>This bit is cleared by writing a 1. Clearing this bit also clears the <code>INR1</code> bit in the ADCRIS register.</p>
0	IN0	R/W1C	0	<p>SS0 Interrupt Status and Clear</p> <p>Value Description</p> <p>1 Both the <code>INR0</code> bit in the ADCRIS register and the <code>MASK0</code> bit in the ADCIM register are set, providing a level-based interrupt to the interrupt controller.</p> <p>0 No interrupt has occurred or the interrupt is masked.</p> <p>This bit is cleared by writing a 1. Clearing this bit also clears the <code>INR0</code> bit in the ADCRIS register.</p>

Register 5: ADC Overflow Status (ADCOSTAT), offset 0x010

This register indicates overflow conditions in the sample sequencer FIFOs. Once the overflow condition has been handled by software, the condition can be cleared by writing a 1 to the corresponding bit position.

ADC Overflow Status (ADCOSTAT)

ADC0 base: 0x4003.8000

ADC1 base: 0x4003.9000

Offset 0x010

Type R/W1C, reset 0x0000.0000

	31	30	29	28	27	26	25	24	23	22	21	20	19	18	17	16	
	reserved																
Type	RO	RO	RO	RO	RO	RO	RO	RO	RO	RO	RO	RO	RO	RO	RO	RO	
Reset	0	0	0	0	0	0	0	0	0	0	0	0	0	0	0	0	
	15	14	13	12	11	10	9	8	7	6	5	4	3	2	1	0	
	reserved												OV3	OV2	OV1	OV0	
Type	RO	RO	RO	RO	RO	RO	RO	RO	RO	RO	RO	RO	RO	R/W1C	R/W1C	R/W1C	R/W1C
Reset	0	0	0	0	0	0	0	0	0	0	0	0	0	0	0	0	0

Bit/Field	Name	Type	Reset	Description
31:4	reserved	RO	0x0000.000	Software should not rely on the value of a reserved bit. To provide compatibility with future products, the value of a reserved bit should be preserved across a read-modify-write operation.
3	OV3	R/W1C	0	SS3 FIFO Overflow Value Description 1 The FIFO for Sample Sequencer 3 has hit an overflow condition, meaning that the FIFO is full and a write was requested. When an overflow is detected, the most recent write is dropped. 0 The FIFO has not overflowed. This bit is cleared by writing a 1.
2	OV2	R/W1C	0	SS2 FIFO Overflow Value Description 1 The FIFO for Sample Sequencer 2 has hit an overflow condition, meaning that the FIFO is full and a write was requested. When an overflow is detected, the most recent write is dropped. 0 The FIFO has not overflowed. This bit is cleared by writing a 1.
1	OV1	R/W1C	0	SS1 FIFO Overflow Value Description 1 The FIFO for Sample Sequencer 1 has hit an overflow condition, meaning that the FIFO is full and a write was requested. When an overflow is detected, the most recent write is dropped. 0 The FIFO has not overflowed. This bit is cleared by writing a 1.

Bit/Field	Name	Type	Reset	Description
0	OV0	R/W1C	0	SS0 FIFO Overflow
				Value Description
				1 The FIFO for Sample Sequencer 0 has hit an overflow condition, meaning that the FIFO is full and a write was requested. When an overflow is detected, the most recent write is dropped.
				0 The FIFO has not overflowed.
				This bit is cleared by writing a 1.

Register 6: ADC Event Multiplexer Select (ADCEMUX), offset 0x014

The **ADCEMUX** selects the event (trigger) that initiates sampling for each sample sequencer. Each sample sequencer can be configured with a unique trigger source. When using a PWM generator as the trigger source, use the **ADC Trigger Source Select (ADCTSSEL)** register to specify in which PWM module the generator is located.

ADC Event Multiplexer Select (ADCEMUX)

ADC0 base: 0x4003.8000
 ADC1 base: 0x4003.9000
 Offset 0x014
 Type R/W, reset 0x0000.0000

	31	30	29	28	27	26	25	24	23	22	21	20	19	18	17	16
	reserved															
Type	RO	RO	RO	RO	RO	RO	RO	RO	RO	RO	RO	RO	RO	RO	RO	RO
Reset	0	0	0	0	0	0	0	0	0	0	0	0	0	0	0	0
	15	14	13	12	11	10	9	8	7	6	5	4	3	2	1	0
	EM3				EM2				EM1				EM0			
Type	R/W	R/W	R/W	R/W	R/W	R/W	R/W	R/W	R/W	R/W	R/W	R/W	R/W	R/W	R/W	R/W
Reset	0	0	0	0	0	0	0	0	0	0	0	0	0	0	0	0

Bit/Field	Name	Type	Reset	Description
31:16	reserved	RO	0x0000	Software should not rely on the value of a reserved bit. To provide compatibility with future products, the value of a reserved bit should be preserved across a read-modify-write operation.

Bit/Field	Name	Type	Reset	Description																										
15:12	EM3	R/W	0x0	<p>SS3 Trigger Select</p> <p>This field selects the trigger source for Sample Sequencer 3. The valid configurations for this field are:</p> <table border="1"> <thead> <tr> <th>Value</th> <th>Event</th> </tr> </thead> <tbody> <tr> <td>0x0</td> <td> <p>Processor (default)</p> <p>The trigger is initiated by setting the SS_n bit in the ADCPSSI register.</p> </td> </tr> <tr> <td>0x1</td> <td> <p>Analog Comparator 0</p> <p>This trigger is configured by the Analog Comparator Control 0 (ACCTL0) register (page 1186).</p> </td> </tr> <tr> <td>0x2</td> <td> <p>Analog Comparator 1</p> <p>This trigger is configured by the Analog Comparator Control 1 (ACCTL1) register (page 1186).</p> </td> </tr> <tr> <td>0x3</td> <td>reserved</td> </tr> <tr> <td>0x4</td> <td> <p>External (GPIO Pins)</p> <p>This trigger is connected to the GPIO interrupt for the corresponding GPIO (see “ADC Trigger Source” on page 629).</p> <p>Note: GPIOs that have AIN_x signals as alternate functions can be used to trigger the ADC. However, the pin cannot be used as both a GPIO and an analog input.</p> </td> </tr> <tr> <td>0x5</td> <td> <p>Timer</p> <p>In addition, the trigger must be enabled with the $TnOTE$ bit in the GPTMCTL register (page 710).</p> </td> </tr> <tr> <td>0x6</td> <td> <p>PWM0</p> <p>The PWM generator 0 trigger can be configured with the PWM0 Interrupt and Trigger Enable (PWM0INTEN) register (page 1233).</p> </td> </tr> <tr> <td>0x7</td> <td> <p>PWM1</p> <p>The PWM generator 1 trigger can be configured with the PWM1INTEN register (page 1233).</p> </td> </tr> <tr> <td>0x8</td> <td> <p>PWM2</p> <p>The PWM generator 2 trigger can be configured with the PWM2INTEN register (page 1233).</p> </td> </tr> <tr> <td>0x9</td> <td> <p>PWM3</p> <p>The PWM generator 3 trigger can be configured with the PWM3INTEN register (page 1233).</p> </td> </tr> <tr> <td>0xA-0xE</td> <td>reserved</td> </tr> <tr> <td>0xF</td> <td>Always (continuously sample)</td> </tr> </tbody> </table>	Value	Event	0x0	<p>Processor (default)</p> <p>The trigger is initiated by setting the SS_n bit in the ADCPSSI register.</p>	0x1	<p>Analog Comparator 0</p> <p>This trigger is configured by the Analog Comparator Control 0 (ACCTL0) register (page 1186).</p>	0x2	<p>Analog Comparator 1</p> <p>This trigger is configured by the Analog Comparator Control 1 (ACCTL1) register (page 1186).</p>	0x3	reserved	0x4	<p>External (GPIO Pins)</p> <p>This trigger is connected to the GPIO interrupt for the corresponding GPIO (see “ADC Trigger Source” on page 629).</p> <p>Note: GPIOs that have AIN_x signals as alternate functions can be used to trigger the ADC. However, the pin cannot be used as both a GPIO and an analog input.</p>	0x5	<p>Timer</p> <p>In addition, the trigger must be enabled with the $TnOTE$ bit in the GPTMCTL register (page 710).</p>	0x6	<p>PWM0</p> <p>The PWM generator 0 trigger can be configured with the PWM0 Interrupt and Trigger Enable (PWM0INTEN) register (page 1233).</p>	0x7	<p>PWM1</p> <p>The PWM generator 1 trigger can be configured with the PWM1INTEN register (page 1233).</p>	0x8	<p>PWM2</p> <p>The PWM generator 2 trigger can be configured with the PWM2INTEN register (page 1233).</p>	0x9	<p>PWM3</p> <p>The PWM generator 3 trigger can be configured with the PWM3INTEN register (page 1233).</p>	0xA-0xE	reserved	0xF	Always (continuously sample)
Value	Event																													
0x0	<p>Processor (default)</p> <p>The trigger is initiated by setting the SS_n bit in the ADCPSSI register.</p>																													
0x1	<p>Analog Comparator 0</p> <p>This trigger is configured by the Analog Comparator Control 0 (ACCTL0) register (page 1186).</p>																													
0x2	<p>Analog Comparator 1</p> <p>This trigger is configured by the Analog Comparator Control 1 (ACCTL1) register (page 1186).</p>																													
0x3	reserved																													
0x4	<p>External (GPIO Pins)</p> <p>This trigger is connected to the GPIO interrupt for the corresponding GPIO (see “ADC Trigger Source” on page 629).</p> <p>Note: GPIOs that have AIN_x signals as alternate functions can be used to trigger the ADC. However, the pin cannot be used as both a GPIO and an analog input.</p>																													
0x5	<p>Timer</p> <p>In addition, the trigger must be enabled with the $TnOTE$ bit in the GPTMCTL register (page 710).</p>																													
0x6	<p>PWM0</p> <p>The PWM generator 0 trigger can be configured with the PWM0 Interrupt and Trigger Enable (PWM0INTEN) register (page 1233).</p>																													
0x7	<p>PWM1</p> <p>The PWM generator 1 trigger can be configured with the PWM1INTEN register (page 1233).</p>																													
0x8	<p>PWM2</p> <p>The PWM generator 2 trigger can be configured with the PWM2INTEN register (page 1233).</p>																													
0x9	<p>PWM3</p> <p>The PWM generator 3 trigger can be configured with the PWM3INTEN register (page 1233).</p>																													
0xA-0xE	reserved																													
0xF	Always (continuously sample)																													

Bit/Field	Name	Type	Reset	Description																										
11:8	EM2	R/W	0x0	<p>SS2 Trigger Select</p> <p>This field selects the trigger source for Sample Sequencer 2.</p> <p>The valid configurations for this field are:</p> <table border="1"> <thead> <tr> <th>Value</th> <th>Event</th> </tr> </thead> <tbody> <tr> <td>0x0</td> <td> <p>Processor (default)</p> <p>The trigger is initiated by setting the SS_n bit in the ADCPSSI register.</p> </td> </tr> <tr> <td>0x1</td> <td> <p>Analog Comparator 0</p> <p>This trigger is configured by the Analog Comparator Control 0 (ACCTL0) register (page 1186).</p> </td> </tr> <tr> <td>0x2</td> <td> <p>Analog Comparator 1</p> <p>This trigger is configured by the Analog Comparator Control 1 (ACCTL1) register (page 1186).</p> </td> </tr> <tr> <td>0x3</td> <td>reserved</td> </tr> <tr> <td>0x4</td> <td> <p>External (GPIO Pins)</p> <p>This trigger is connected to the GPIO interrupt for the corresponding GPIO (see “ADC Trigger Source” on page 629).</p> <p>Note: GPIOs that have AIN_x signals as alternate functions can be used to trigger the ADC. However, the pin cannot be used as both a GPIO and an analog input.</p> </td> </tr> <tr> <td>0x5</td> <td> <p>Timer</p> <p>In addition, the trigger must be enabled with the $TnOTE$ bit in the GPTMCTL register (page 710).</p> </td> </tr> <tr> <td>0x6</td> <td> <p>PWM0</p> <p>The PWM generator 0 trigger can be configured with the PWM0 Interrupt and Trigger Enable (PWM0INTEN) register (page 1233).</p> </td> </tr> <tr> <td>0x7</td> <td> <p>PWM1</p> <p>The PWM generator 1 trigger can be configured with the PWM1INTEN register (page 1233).</p> </td> </tr> <tr> <td>0x8</td> <td> <p>PWM2</p> <p>The PWM generator 2 trigger can be configured with the PWM2INTEN register (page 1233).</p> </td> </tr> <tr> <td>0x9</td> <td> <p>PWM3</p> <p>The PWM generator 3 trigger can be configured with the PWM3INTEN register (page 1233).</p> </td> </tr> <tr> <td>0xA-0xE</td> <td>reserved</td> </tr> <tr> <td>0xF</td> <td>Always (continuously sample)</td> </tr> </tbody> </table>	Value	Event	0x0	<p>Processor (default)</p> <p>The trigger is initiated by setting the SS_n bit in the ADCPSSI register.</p>	0x1	<p>Analog Comparator 0</p> <p>This trigger is configured by the Analog Comparator Control 0 (ACCTL0) register (page 1186).</p>	0x2	<p>Analog Comparator 1</p> <p>This trigger is configured by the Analog Comparator Control 1 (ACCTL1) register (page 1186).</p>	0x3	reserved	0x4	<p>External (GPIO Pins)</p> <p>This trigger is connected to the GPIO interrupt for the corresponding GPIO (see “ADC Trigger Source” on page 629).</p> <p>Note: GPIOs that have AIN_x signals as alternate functions can be used to trigger the ADC. However, the pin cannot be used as both a GPIO and an analog input.</p>	0x5	<p>Timer</p> <p>In addition, the trigger must be enabled with the $TnOTE$ bit in the GPTMCTL register (page 710).</p>	0x6	<p>PWM0</p> <p>The PWM generator 0 trigger can be configured with the PWM0 Interrupt and Trigger Enable (PWM0INTEN) register (page 1233).</p>	0x7	<p>PWM1</p> <p>The PWM generator 1 trigger can be configured with the PWM1INTEN register (page 1233).</p>	0x8	<p>PWM2</p> <p>The PWM generator 2 trigger can be configured with the PWM2INTEN register (page 1233).</p>	0x9	<p>PWM3</p> <p>The PWM generator 3 trigger can be configured with the PWM3INTEN register (page 1233).</p>	0xA-0xE	reserved	0xF	Always (continuously sample)
Value	Event																													
0x0	<p>Processor (default)</p> <p>The trigger is initiated by setting the SS_n bit in the ADCPSSI register.</p>																													
0x1	<p>Analog Comparator 0</p> <p>This trigger is configured by the Analog Comparator Control 0 (ACCTL0) register (page 1186).</p>																													
0x2	<p>Analog Comparator 1</p> <p>This trigger is configured by the Analog Comparator Control 1 (ACCTL1) register (page 1186).</p>																													
0x3	reserved																													
0x4	<p>External (GPIO Pins)</p> <p>This trigger is connected to the GPIO interrupt for the corresponding GPIO (see “ADC Trigger Source” on page 629).</p> <p>Note: GPIOs that have AIN_x signals as alternate functions can be used to trigger the ADC. However, the pin cannot be used as both a GPIO and an analog input.</p>																													
0x5	<p>Timer</p> <p>In addition, the trigger must be enabled with the $TnOTE$ bit in the GPTMCTL register (page 710).</p>																													
0x6	<p>PWM0</p> <p>The PWM generator 0 trigger can be configured with the PWM0 Interrupt and Trigger Enable (PWM0INTEN) register (page 1233).</p>																													
0x7	<p>PWM1</p> <p>The PWM generator 1 trigger can be configured with the PWM1INTEN register (page 1233).</p>																													
0x8	<p>PWM2</p> <p>The PWM generator 2 trigger can be configured with the PWM2INTEN register (page 1233).</p>																													
0x9	<p>PWM3</p> <p>The PWM generator 3 trigger can be configured with the PWM3INTEN register (page 1233).</p>																													
0xA-0xE	reserved																													
0xF	Always (continuously sample)																													

Bit/Field	Name	Type	Reset	Description																										
7:4	EM1	R/W	0x0	<p>SS1 Trigger Select</p> <p>This field selects the trigger source for Sample Sequencer 1. The valid configurations for this field are:</p> <table border="1"> <thead> <tr> <th>Value</th> <th>Event</th> </tr> </thead> <tbody> <tr> <td>0x0</td> <td> <p>Processor (default)</p> <p>The trigger is initiated by setting the SS_n bit in the ADCPSSI register.</p> </td> </tr> <tr> <td>0x1</td> <td> <p>Analog Comparator 0</p> <p>This trigger is configured by the Analog Comparator Control 0 (ACCTL0) register (page 1186).</p> </td> </tr> <tr> <td>0x2</td> <td> <p>Analog Comparator 1</p> <p>This trigger is configured by the Analog Comparator Control 1 (ACCTL1) register (page 1186).</p> </td> </tr> <tr> <td>0x3</td> <td>reserved</td> </tr> <tr> <td>0x4</td> <td> <p>External (GPIO Pins)</p> <p>This trigger is connected to the GPIO interrupt for the corresponding GPIO (see “ADC Trigger Source” on page 629).</p> <p>Note: GPIOs that have AIN_x signals as alternate functions can be used to trigger the ADC. However, the pin cannot be used as both a GPIO and an analog input.</p> </td> </tr> <tr> <td>0x5</td> <td> <p>Timer</p> <p>In addition, the trigger must be enabled with the $TnOTE$ bit in the GPTMCTL register (page 710).</p> </td> </tr> <tr> <td>0x6</td> <td> <p>PWM0</p> <p>The PWM generator 0 trigger can be configured with the PWM0 Interrupt and Trigger Enable (PWM0INTEN) register (page 1233).</p> </td> </tr> <tr> <td>0x7</td> <td> <p>PWM1</p> <p>The PWM generator 1 trigger can be configured with the PWM1INTEN register (page 1233).</p> </td> </tr> <tr> <td>0x8</td> <td> <p>PWM2</p> <p>The PWM generator 2 trigger can be configured with the PWM2INTEN register (page 1233).</p> </td> </tr> <tr> <td>0x9</td> <td> <p>PWM3</p> <p>The PWM generator 3 trigger can be configured with the PWM3INTEN register (page 1233).</p> </td> </tr> <tr> <td>0xA-0xE</td> <td>reserved</td> </tr> <tr> <td>0xF</td> <td>Always (continuously sample)</td> </tr> </tbody> </table>	Value	Event	0x0	<p>Processor (default)</p> <p>The trigger is initiated by setting the SS_n bit in the ADCPSSI register.</p>	0x1	<p>Analog Comparator 0</p> <p>This trigger is configured by the Analog Comparator Control 0 (ACCTL0) register (page 1186).</p>	0x2	<p>Analog Comparator 1</p> <p>This trigger is configured by the Analog Comparator Control 1 (ACCTL1) register (page 1186).</p>	0x3	reserved	0x4	<p>External (GPIO Pins)</p> <p>This trigger is connected to the GPIO interrupt for the corresponding GPIO (see “ADC Trigger Source” on page 629).</p> <p>Note: GPIOs that have AIN_x signals as alternate functions can be used to trigger the ADC. However, the pin cannot be used as both a GPIO and an analog input.</p>	0x5	<p>Timer</p> <p>In addition, the trigger must be enabled with the $TnOTE$ bit in the GPTMCTL register (page 710).</p>	0x6	<p>PWM0</p> <p>The PWM generator 0 trigger can be configured with the PWM0 Interrupt and Trigger Enable (PWM0INTEN) register (page 1233).</p>	0x7	<p>PWM1</p> <p>The PWM generator 1 trigger can be configured with the PWM1INTEN register (page 1233).</p>	0x8	<p>PWM2</p> <p>The PWM generator 2 trigger can be configured with the PWM2INTEN register (page 1233).</p>	0x9	<p>PWM3</p> <p>The PWM generator 3 trigger can be configured with the PWM3INTEN register (page 1233).</p>	0xA-0xE	reserved	0xF	Always (continuously sample)
Value	Event																													
0x0	<p>Processor (default)</p> <p>The trigger is initiated by setting the SS_n bit in the ADCPSSI register.</p>																													
0x1	<p>Analog Comparator 0</p> <p>This trigger is configured by the Analog Comparator Control 0 (ACCTL0) register (page 1186).</p>																													
0x2	<p>Analog Comparator 1</p> <p>This trigger is configured by the Analog Comparator Control 1 (ACCTL1) register (page 1186).</p>																													
0x3	reserved																													
0x4	<p>External (GPIO Pins)</p> <p>This trigger is connected to the GPIO interrupt for the corresponding GPIO (see “ADC Trigger Source” on page 629).</p> <p>Note: GPIOs that have AIN_x signals as alternate functions can be used to trigger the ADC. However, the pin cannot be used as both a GPIO and an analog input.</p>																													
0x5	<p>Timer</p> <p>In addition, the trigger must be enabled with the $TnOTE$ bit in the GPTMCTL register (page 710).</p>																													
0x6	<p>PWM0</p> <p>The PWM generator 0 trigger can be configured with the PWM0 Interrupt and Trigger Enable (PWM0INTEN) register (page 1233).</p>																													
0x7	<p>PWM1</p> <p>The PWM generator 1 trigger can be configured with the PWM1INTEN register (page 1233).</p>																													
0x8	<p>PWM2</p> <p>The PWM generator 2 trigger can be configured with the PWM2INTEN register (page 1233).</p>																													
0x9	<p>PWM3</p> <p>The PWM generator 3 trigger can be configured with the PWM3INTEN register (page 1233).</p>																													
0xA-0xE	reserved																													
0xF	Always (continuously sample)																													

Bit/Field	Name	Type	Reset	Description																										
3:0	EM0	R/W	0x0	<p>SS0 Trigger Select</p> <p>This field selects the trigger source for Sample Sequencer 0</p> <p>The valid configurations for this field are:</p> <table border="1"> <thead> <tr> <th>Value</th> <th>Event</th> </tr> </thead> <tbody> <tr> <td>0x0</td> <td> <p>Processor (default)</p> <p>The trigger is initiated by setting the <code>SSn</code> bit in the ADCPSSI register.</p> </td> </tr> <tr> <td>0x1</td> <td> <p>Analog Comparator 0</p> <p>This trigger is configured by the Analog Comparator Control 0 (ACCTL0) register (page 1186).</p> </td> </tr> <tr> <td>0x2</td> <td> <p>Analog Comparator 1</p> <p>This trigger is configured by the Analog Comparator Control 1 (ACCTL1) register (page 1186).</p> </td> </tr> <tr> <td>0x3</td> <td>reserved</td> </tr> <tr> <td>0x4</td> <td> <p>External (GPIO Pins)</p> <p>This trigger is connected to the GPIO interrupt for the corresponding GPIO (see "ADC Trigger Source" on page 629).</p> <p>Note: GPIOs that have <code>AINx</code> signals as alternate functions can be used to trigger the ADC. However, the pin cannot be used as both a GPIO and an analog input.</p> </td> </tr> <tr> <td>0x5</td> <td> <p>Timer</p> <p>In addition, the trigger must be enabled with the <code>TnOTE</code> bit in the GPTMCTL register (page 710).</p> </td> </tr> <tr> <td>0x6</td> <td> <p>PWM0</p> <p>The PWM generator 0 trigger can be configured with the PWM0 Interrupt and Trigger Enable (PWM0INTEN) register (page 1233).</p> </td> </tr> <tr> <td>0x7</td> <td> <p>PWM1</p> <p>The PWM generator 1 trigger can be configured with the PWM1INTEN register (page 1233).</p> </td> </tr> <tr> <td>0x8</td> <td> <p>PWM2</p> <p>The PWM generator 2 trigger can be configured with the PWM2INTEN register (page 1233).</p> </td> </tr> <tr> <td>0x9</td> <td> <p>PWM3</p> <p>The PWM generator 3 trigger can be configured with the PWM3INTEN register (page 1233).</p> </td> </tr> <tr> <td>0xA-0xE</td> <td>reserved</td> </tr> <tr> <td>0xF</td> <td>Always (continuously sample)</td> </tr> </tbody> </table>	Value	Event	0x0	<p>Processor (default)</p> <p>The trigger is initiated by setting the <code>SSn</code> bit in the ADCPSSI register.</p>	0x1	<p>Analog Comparator 0</p> <p>This trigger is configured by the Analog Comparator Control 0 (ACCTL0) register (page 1186).</p>	0x2	<p>Analog Comparator 1</p> <p>This trigger is configured by the Analog Comparator Control 1 (ACCTL1) register (page 1186).</p>	0x3	reserved	0x4	<p>External (GPIO Pins)</p> <p>This trigger is connected to the GPIO interrupt for the corresponding GPIO (see "ADC Trigger Source" on page 629).</p> <p>Note: GPIOs that have <code>AINx</code> signals as alternate functions can be used to trigger the ADC. However, the pin cannot be used as both a GPIO and an analog input.</p>	0x5	<p>Timer</p> <p>In addition, the trigger must be enabled with the <code>TnOTE</code> bit in the GPTMCTL register (page 710).</p>	0x6	<p>PWM0</p> <p>The PWM generator 0 trigger can be configured with the PWM0 Interrupt and Trigger Enable (PWM0INTEN) register (page 1233).</p>	0x7	<p>PWM1</p> <p>The PWM generator 1 trigger can be configured with the PWM1INTEN register (page 1233).</p>	0x8	<p>PWM2</p> <p>The PWM generator 2 trigger can be configured with the PWM2INTEN register (page 1233).</p>	0x9	<p>PWM3</p> <p>The PWM generator 3 trigger can be configured with the PWM3INTEN register (page 1233).</p>	0xA-0xE	reserved	0xF	Always (continuously sample)
Value	Event																													
0x0	<p>Processor (default)</p> <p>The trigger is initiated by setting the <code>SSn</code> bit in the ADCPSSI register.</p>																													
0x1	<p>Analog Comparator 0</p> <p>This trigger is configured by the Analog Comparator Control 0 (ACCTL0) register (page 1186).</p>																													
0x2	<p>Analog Comparator 1</p> <p>This trigger is configured by the Analog Comparator Control 1 (ACCTL1) register (page 1186).</p>																													
0x3	reserved																													
0x4	<p>External (GPIO Pins)</p> <p>This trigger is connected to the GPIO interrupt for the corresponding GPIO (see "ADC Trigger Source" on page 629).</p> <p>Note: GPIOs that have <code>AINx</code> signals as alternate functions can be used to trigger the ADC. However, the pin cannot be used as both a GPIO and an analog input.</p>																													
0x5	<p>Timer</p> <p>In addition, the trigger must be enabled with the <code>TnOTE</code> bit in the GPTMCTL register (page 710).</p>																													
0x6	<p>PWM0</p> <p>The PWM generator 0 trigger can be configured with the PWM0 Interrupt and Trigger Enable (PWM0INTEN) register (page 1233).</p>																													
0x7	<p>PWM1</p> <p>The PWM generator 1 trigger can be configured with the PWM1INTEN register (page 1233).</p>																													
0x8	<p>PWM2</p> <p>The PWM generator 2 trigger can be configured with the PWM2INTEN register (page 1233).</p>																													
0x9	<p>PWM3</p> <p>The PWM generator 3 trigger can be configured with the PWM3INTEN register (page 1233).</p>																													
0xA-0xE	reserved																													
0xF	Always (continuously sample)																													

Register 7: ADC Underflow Status (ADCUSTAT), offset 0x018

This register indicates underflow conditions in the sample sequencer FIFOs. The corresponding underflow condition is cleared by writing a 1 to the relevant bit position.

ADC Underflow Status (ADCUSTAT)

ADC0 base: 0x4003.8000
 ADC1 base: 0x4003.9000
 Offset 0x018
 Type R/W1C, reset 0x0000.0000

	31	30	29	28	27	26	25	24	23	22	21	20	19	18	17	16	
	reserved																
Type	RO	RO	RO	RO	RO	RO	RO	RO	RO	RO	RO	RO	RO	RO	RO	RO	
Reset	0	0	0	0	0	0	0	0	0	0	0	0	0	0	0	0	
	15	14	13	12	11	10	9	8	7	6	5	4	3	2	1	0	
	reserved												UV3	UV2	UV1	UV0	
Type	RO	RO	RO	RO	RO	RO	RO	RO	RO	RO	RO	RO	RO	R/W1C	R/W1C	R/W1C	R/W1C
Reset	0	0	0	0	0	0	0	0	0	0	0	0	0	0	0	0	0

Bit/Field	Name	Type	Reset	Description						
31:4	reserved	RO	0x0000.000	Software should not rely on the value of a reserved bit. To provide compatibility with future products, the value of a reserved bit should be preserved across a read-modify-write operation.						
3	UV3	R/W1C	0	<p>SS3 FIFO Underflow</p> <p>The valid configurations for this field are shown below. This bit is cleared by writing a 1.</p> <table border="1"> <thead> <tr> <th>Value</th> <th>Description</th> </tr> </thead> <tbody> <tr> <td>1</td> <td>The FIFO for the Sample Sequencer has hit an underflow condition, meaning that the FIFO is empty and a read was requested. The problematic read does not move the FIFO pointers, and 0s are returned.</td> </tr> <tr> <td>0</td> <td>The FIFO has not underflowed.</td> </tr> </tbody> </table>	Value	Description	1	The FIFO for the Sample Sequencer has hit an underflow condition, meaning that the FIFO is empty and a read was requested. The problematic read does not move the FIFO pointers, and 0s are returned.	0	The FIFO has not underflowed.
Value	Description									
1	The FIFO for the Sample Sequencer has hit an underflow condition, meaning that the FIFO is empty and a read was requested. The problematic read does not move the FIFO pointers, and 0s are returned.									
0	The FIFO has not underflowed.									
2	UV2	R/W1C	0	<p>SS2 FIFO Underflow</p> <p>The valid configurations are the same as those for the UV3 field. This bit is cleared by writing a 1.</p>						
1	UV1	R/W1C	0	<p>SS1 FIFO Underflow</p> <p>The valid configurations are the same as those for the UV3 field. This bit is cleared by writing a 1.</p>						
0	UV0	R/W1C	0	<p>SS0 FIFO Underflow</p> <p>The valid configurations are the same as those for the UV3 field. This bit is cleared by writing a 1.</p>						

Register 8: ADC Trigger Source Select (ADCTSSEL), offset 0x01C

The **ADCTSSEL** register specifies which PWM module is selected with the EM_n bit field in the **ADC Event Multiplexer Select (ADCEMUX)** register. The register resets to 0x0000.0000, which selects PWM module 0 for all generators.

ADC Trigger Source Select (ADCTSSEL)

ADC0 base: 0x4003.8000
 ADC1 base: 0x4003.9000
 Offset 0x01C
 Type R/W, reset 0x0000.0000

	31	30	29	28	27	26	25	24	23	22	21	20	19	18	17	16
	reserved		PS3		reserved						PS2		reserved			
Type	RO	RO	R/W	R/W	RO	RO	RO	RO	RO	RO	R/W	R/W	RO	RO	RO	RO
Reset	0	0	0	0	0	0	0	0	0	0	0	0	0	0	0	0
	15	14	13	12	11	10	9	8	7	6	5	4	3	2	1	0
	reserved		PS1		reserved						PS0		reserved			
Type	RO	RO	R/W	R/W	RO	RO	RO	RO	RO	RO	R/W	R/W	RO	RO	RO	RO
Reset	0	0	0	0	0	0	0	0	0	0	0	0	0	0	0	0

Bit/Field	Name	Type	Reset	Description								
31:30	reserved	RO	0x0	Software should not rely on the value of a reserved bit. To provide compatibility with future products, the value of a reserved bit should be preserved across a read-modify-write operation.								
29:28	PS3	R/W	0x0	EM3 PWM Generator Select This field selects which PWM generator signals are used in the PWM0-PWM3 encodings of the ADCEMUX register EM_3 bit field. <table border="0"> <tr> <td>Value</td> <td>Description</td> </tr> <tr> <td>0x0</td> <td>PWM generator 0</td> </tr> <tr> <td>0x1</td> <td>PWM generator 1</td> </tr> <tr> <td>0x2 - 0x3</td> <td>reserved</td> </tr> </table>	Value	Description	0x0	PWM generator 0	0x1	PWM generator 1	0x2 - 0x3	reserved
Value	Description											
0x0	PWM generator 0											
0x1	PWM generator 1											
0x2 - 0x3	reserved											
27:22	reserved	RO	0x0	Software should not rely on the value of a reserved bit. To provide compatibility with future products, the value of a reserved bit should be preserved across a read-modify-write operation.								
21:20	PS2	R/W	0x0	EM2 PWM Generator Select This field selects which PWM generator signals are used in the PWM0-PWM3 encodings of the ADCEMUX register EM_2 bit field. <table border="0"> <tr> <td>Value</td> <td>Description</td> </tr> <tr> <td>0x0</td> <td>PWM generator 0</td> </tr> <tr> <td>0x1</td> <td>PWM generator 1</td> </tr> <tr> <td>0x2 - 0x3</td> <td>reserved</td> </tr> </table>	Value	Description	0x0	PWM generator 0	0x1	PWM generator 1	0x2 - 0x3	reserved
Value	Description											
0x0	PWM generator 0											
0x1	PWM generator 1											
0x2 - 0x3	reserved											
19:14	reserved	RO	0x0	Software should not rely on the value of a reserved bit. To provide compatibility with future products, the value of a reserved bit should be preserved across a read-modify-write operation.								

Bit/Field	Name	Type	Reset	Description								
13:12	PS1	R/W	0x0	<p>EM1 PWM Generator Select</p> <p>This field selects which PWM generator signals are used in the PWM0-PWM3 encodings of the ADCEMUX register EM1 bit field.</p> <table border="1"> <thead> <tr> <th>Value</th> <th>Description</th> </tr> </thead> <tbody> <tr> <td>0x0</td> <td>PWM generator 0</td> </tr> <tr> <td>0x1</td> <td>PWM generator 1</td> </tr> <tr> <td>0x2 - 0x3</td> <td>reserved</td> </tr> </tbody> </table>	Value	Description	0x0	PWM generator 0	0x1	PWM generator 1	0x2 - 0x3	reserved
Value	Description											
0x0	PWM generator 0											
0x1	PWM generator 1											
0x2 - 0x3	reserved											
11:6	reserved	RO	0x0	Software should not rely on the value of a reserved bit. To provide compatibility with future products, the value of a reserved bit should be preserved across a read-modify-write operation.								
5:4	PS0	R/W	0x0	<p>EM0 PWM Generator Select</p> <p>This field selects which PWM generator signals are used in the PWM0-PWM3 encodings of the ADCEMUX register EM0 bit field.</p> <table border="1"> <thead> <tr> <th>Value</th> <th>Description</th> </tr> </thead> <tbody> <tr> <td>0x0</td> <td>PWM generator 0</td> </tr> <tr> <td>0x1</td> <td>PWM generator 1</td> </tr> <tr> <td>0x2 - 0x3</td> <td>reserved</td> </tr> </tbody> </table>	Value	Description	0x0	PWM generator 0	0x1	PWM generator 1	0x2 - 0x3	reserved
Value	Description											
0x0	PWM generator 0											
0x1	PWM generator 1											
0x2 - 0x3	reserved											
3:0	reserved	RO	0x0	Software should not rely on the value of a reserved bit. To provide compatibility with future products, the value of a reserved bit should be preserved across a read-modify-write operation.								

Register 9: ADC Sample Sequencer Priority (ADCSSPRI), offset 0x020

This register sets the priority for each of the sample sequencers. Out of reset, Sequencer 0 has the highest priority, and Sequencer 3 has the lowest priority. When reconfiguring sequence priorities, each sequence must have a unique priority for the ADC to operate properly.

ADC Sample Sequencer Priority (ADCSSPRI)

ADC0 base: 0x4003.8000
 ADC1 base: 0x4003.9000
 Offset 0x020
 Type R/W, reset 0x0000.3210

	31	30	29	28	27	26	25	24	23	22	21	20	19	18	17	16
	reserved															
Type	RO	RO	RO	RO	RO	RO	RO	RO	RO	RO	RO	RO	RO	RO	RO	RO
Reset	0	0	0	0	0	0	0	0	0	0	0	0	0	0	0	0
	15	14	13	12	11	10	9	8	7	6	5	4	3	2	1	0
	reserved		SS3		reserved		SS2		reserved		SS1		reserved		SS0	
Type	RO	RO	R/W	R/W	RO	RO	R/W	R/W	RO	RO	R/W	R/W	RO	RO	R/W	R/W
Reset	0	0	1	1	0	0	1	0	0	0	0	1	0	0	0	0

Bit/Field	Name	Type	Reset	Description
31:14	reserved	RO	0x0000.0	Software should not rely on the value of a reserved bit. To provide compatibility with future products, the value of a reserved bit should be preserved across a read-modify-write operation.
13:12	SS3	R/W	0x3	SS3 Priority This field contains a binary-encoded value that specifies the priority encoding of Sample Sequencer 3. A priority encoding of 0x0 is highest and 0x3 is lowest. The priorities assigned to the sequencers must be uniquely mapped. The ADC may not operate properly if two or more fields are equal.
11:10	reserved	RO	0x0	Software should not rely on the value of a reserved bit. To provide compatibility with future products, the value of a reserved bit should be preserved across a read-modify-write operation.
9:8	SS2	R/W	0x2	SS2 Priority This field contains a binary-encoded value that specifies the priority encoding of Sample Sequencer 2. A priority encoding of 0x0 is highest and 0x3 is lowest. The priorities assigned to the sequencers must be uniquely mapped. The ADC may not operate properly if two or more fields are equal.
7:6	reserved	RO	0x0	Software should not rely on the value of a reserved bit. To provide compatibility with future products, the value of a reserved bit should be preserved across a read-modify-write operation.
5:4	SS1	R/W	0x1	SS1 Priority This field contains a binary-encoded value that specifies the priority encoding of Sample Sequencer 1. A priority encoding of 0x0 is highest and 0x3 is lowest. The priorities assigned to the sequencers must be uniquely mapped. The ADC may not operate properly if two or more fields are equal.
3:2	reserved	RO	0x0	Software should not rely on the value of a reserved bit. To provide compatibility with future products, the value of a reserved bit should be preserved across a read-modify-write operation.

Bit/Field	Name	Type	Reset	Description
1:0	SS0	R/W	0x0	SS0 Priority This field contains a binary-encoded value that specifies the priority encoding of Sample Sequencer 0. A priority encoding of 0x0 is highest and 0x3 is lowest. The priorities assigned to the sequencers must be uniquely mapped. The ADC may not operate properly if two or more fields are equal.

Register 10: ADC Sample Phase Control (ADCSPC), offset 0x024

This register allows the ADC module to sample at one of 16 different discrete phases from 0.0° through 337.5°. For example, the sample rate could be effectively doubled by sampling a signal using one ADC module configured with the standard sample time and the second ADC module configured with a 180.0° phase lag.

Note: Care should be taken when the PHASE field is non-zero, as the resulting delay in sampling the AIN_x input may result in undesirable system consequences. The time from ADC trigger to sample is increased and could make the response time longer than anticipated. The added latency could have ramifications in the system design. Designers should carefully consider the impact of this delay.

ADC Sample Phase Control (ADCSPC)

ADC0 base: 0x4003.8000

ADC1 base: 0x4003.9000

Offset 0x024

Type R/W, reset 0x0000.0000

	31	30	29	28	27	26	25	24	23	22	21	20	19	18	17	16
	reserved															
Type	RO	RO	RO	RO	RO	RO	RO	RO	RO	RO	RO	RO	RO	RO	RO	RO
Reset	0	0	0	0	0	0	0	0	0	0	0	0	0	0	0	0
	15	14	13	12	11	10	9	8	7	6	5	4	3	2	1	0
	reserved												PHASE			
Type	RO	RO	RO	RO	RO	RO	RO	RO	RO	RO	RO	RO	R/W	R/W	R/W	R/W
Reset	0	0	0	0	0	0	0	0	0	0	0	0	0	0	0	0

Bit/Field	Name	Type	Reset	Description
31:4	reserved	RO	0x0000.000	Software should not rely on the value of a reserved bit. To provide compatibility with future products, the value of a reserved bit should be preserved across a read-modify-write operation.

Bit/Field	Name	Type	Reset	Description
3:0	PHASE	R/W	0x0	Phase Difference This field selects the sample phase difference from the standard sample time. Value Description 0x0 ADC sample lags by 0.0° 0x1 ADC sample lags by 22.5° 0x2 ADC sample lags by 45.0° 0x3 ADC sample lags by 67.5° 0x4 ADC sample lags by 90.0° 0x5 ADC sample lags by 112.5° 0x6 ADC sample lags by 135.0° 0x7 ADC sample lags by 157.5° 0x8 ADC sample lags by 180.0° 0x9 ADC sample lags by 202.5° 0xA ADC sample lags by 225.0° 0xB ADC sample lags by 247.5° 0xC ADC sample lags by 270.0° 0xD ADC sample lags by 292.5° 0xE ADC sample lags by 315.0° 0xF ADC sample lags by 337.5°

Register 11: ADC Processor Sample Sequence Initiate (ADCPSSI), offset 0x028

This register provides a mechanism for application software to initiate sampling in the sample sequencers. Sample sequences can be initiated individually or in any combination. When multiple sequences are triggered simultaneously, the priority encodings in **ADCSSPRI** dictate execution order.

This register also provides a means to configure and then initiate concurrent sampling on all ADC modules. To do this, the first ADC module should be configured. The **ADCPSSI** register for that module should then be written. The appropriate **SS** bits should be set along with the **SYNCWAIT** bit. Additional ADC modules should then be configured following the same procedure. Once the final ADC module is configured, its **ADCPSSI** register should be written with the appropriate **SS** bits set along with the **GSYNC** bit. All of the ADC modules then begin concurrent sampling according to their configuration.

ADC Processor Sample Sequence Initiate (ADCPSSI)

ADC0 base: 0x4003.8000

ADC1 base: 0x4003.9000

Offset 0x028

Type R/W, reset -

	31	30	29	28	27	26	25	24	23	22	21	20	19	18	17	16	
	GSYNC	reserved				SYNCWAIT	reserved										
Type	R/W	RO	RO	RO	R/W	RO	RO	RO	RO	RO	RO	RO	RO	RO	RO	RO	
Reset	0	0	0	0	0	0	0	0	0	0	0	0	0	0	0	0	
	15	14	13	12	11	10	9	8	7	6	5	4	3	2	1	0	
	reserved												SS3	SS2	SS1	SS0	
Type	RO	RO	RO	RO	RO	RO	RO	RO	RO	RO	RO	RO	RO	WO	WO	WO	WO
Reset	0	0	0	0	0	0	0	0	0	0	0	0	0	-	-	-	-

Bit/Field	Name	Type	Reset	Description
31	GSYNC	R/W	0	Global Synchronize
				Value Description
				1 This bit initiates sampling in multiple ADC modules at the same time. Any ADC module that has been initialized by setting an SS_n bit and the SYNCWAIT bit starts sampling once this bit is written.
				0 This bit is cleared once sampling has been initiated.
30:28	reserved	RO	0x0	Software should not rely on the value of a reserved bit. To provide compatibility with future products, the value of a reserved bit should be preserved across a read-modify-write operation.
27	SYNCWAIT	R/W	0	Synchronize Wait
				Value Description
				1 This bit allows the sample sequences to be initiated, but delays sampling until the GSYNC bit is set.
				0 Sampling begins when a sample sequence has been initiated.
26:4	reserved	RO	0x0000.0	Software should not rely on the value of a reserved bit. To provide compatibility with future products, the value of a reserved bit should be preserved across a read-modify-write operation.

Bit/Field	Name	Type	Reset	Description
3	SS3	WO	-	<p>SS3 Initiate</p> <p>Value Description</p> <p>1 Begin sampling on Sample Sequencer 3, if the sequencer is enabled in the ADCACTSS register.</p> <p>0 No effect.</p> <p>Only a write by software is valid; a read of this register returns no meaningful data.</p>
2	SS2	WO	-	<p>SS2 Initiate</p> <p>Value Description</p> <p>1 Begin sampling on Sample Sequencer 2, if the sequencer is enabled in the ADCACTSS register.</p> <p>0 No effect.</p> <p>Only a write by software is valid; a read of this register returns no meaningful data.</p>
1	SS1	WO	-	<p>SS1 Initiate</p> <p>Value Description</p> <p>1 Begin sampling on Sample Sequencer 1, if the sequencer is enabled in the ADCACTSS register.</p> <p>0 No effect.</p> <p>Only a write by software is valid; a read of this register returns no meaningful data.</p>
0	SS0	WO	-	<p>SS0 Initiate</p> <p>Value Description</p> <p>1 Begin sampling on Sample Sequencer 0, if the sequencer is enabled in the ADCACTSS register.</p> <p>0 No effect.</p> <p>Only a write by software is valid; a read of this register returns no meaningful data.</p>

Register 12: ADC Sample Averaging Control (ADCSAC), offset 0x030

This register controls the amount of hardware averaging applied to conversion results. The final conversion result stored in the FIFO is averaged from 2^{AVG} consecutive ADC samples at the specified ADC speed. If AVG is 0, the sample is passed directly through without any averaging. If AVG=6, then 64 consecutive ADC samples are averaged to generate one result in the sequencer FIFO. An AVG=7 provides unpredictable results.

ADC Sample Averaging Control (ADCSAC)

ADC0 base: 0x4003.8000
 ADC1 base: 0x4003.9000
 Offset 0x030
 Type R/W, reset 0x0000.0000

	31	30	29	28	27	26	25	24	23	22	21	20	19	18	17	16	
	reserved																
Type	RO	RO	RO	RO	RO	RO	RO	RO	RO	RO	RO	RO	RO	RO	RO	RO	
Reset	0	0	0	0	0	0	0	0	0	0	0	0	0	0	0	0	
	15	14	13	12	11	10	9	8	7	6	5	4	3	2	1	0	
	reserved													AVG			
Type	RO	RO	RO	RO	RO	RO	RO	RO	RO	RO	RO	RO	RO	RO	R/W	R/W	R/W
Reset	0	0	0	0	0	0	0	0	0	0	0	0	0	0	0	0	0

Bit/Field	Name	Type	Reset	Description
31:3	reserved	RO	0x0000.000	Software should not rely on the value of a reserved bit. To provide compatibility with future products, the value of a reserved bit should be preserved across a read-modify-write operation.
2:0	AVG	R/W	0x0	Hardware Averaging Control Specifies the amount of hardware averaging that will be applied to ADC samples. The AVG field can be any value between 0 and 6. Entering a value of 7 creates unpredictable results.
				Value Description
				0x0 No hardware oversampling
				0x1 2x hardware oversampling
				0x2 4x hardware oversampling
				0x3 8x hardware oversampling
				0x4 16x hardware oversampling
				0x5 32x hardware oversampling
				0x6 64x hardware oversampling
				0x7 reserved

Register 13: ADC Digital Comparator Interrupt Status and Clear (ADCDCISC), offset 0x034

This register provides status and acknowledgement of digital comparator interrupts. One bit is provided for each comparator.

ADC Digital Comparator Interrupt Status and Clear (ADCDCISC)

ADC0 base: 0x4003.8000
 ADC1 base: 0x4003.9000
 Offset 0x034
 Type R/W1C, reset 0x0000.0000

	31	30	29	28	27	26	25	24	23	22	21	20	19	18	17	16
	reserved															
Type	RO	RO	RO	RO	RO	RO	RO	RO	RO	RO	RO	RO	RO	RO	RO	RO
Reset	0	0	0	0	0	0	0	0	0	0	0	0	0	0	0	0
	15	14	13	12	11	10	9	8	7	6	5	4	3	2	1	0
	reserved								DCINT7	DCINT6	DCINT5	DCINT4	DCINT3	DCINT2	DCINT1	DCINT0
Type	RO	RO	RO	RO	RO	RO	RO	RO	R/W1C	R/W1C	R/W1C	R/W1C	R/W1C	R/W1C	R/W1C	R/W1C
Reset	0	0	0	0	0	0	0	0	0	0	0	0	0	0	0	0

Bit/Field	Name	Type	Reset	Description
31:8	reserved	RO	0x0000.00	Software should not rely on the value of a reserved bit. To provide compatibility with future products, the value of a reserved bit should be preserved across a read-modify-write operation.
7	DCINT7	R/W1C	0	Digital Comparator 7 Interrupt Status and Clear Value Description 1 Digital Comparator 7 has generated an interrupt. 0 No interrupt. This bit is cleared by writing a 1.
6	DCINT6	R/W1C	0	Digital Comparator 6 Interrupt Status and Clear Value Description 1 Digital Comparator 6 has generated an interrupt. 0 No interrupt. This bit is cleared by writing a 1.
5	DCINT5	R/W1C	0	Digital Comparator 5 Interrupt Status and Clear Value Description 1 Digital Comparator 5 has generated an interrupt. 0 No interrupt. This bit is cleared by writing a 1.

Bit/Field	Name	Type	Reset	Description
4	DCINT4	R/W1C	0	<p>Digital Comparator 4 Interrupt Status and Clear</p> <p>Value Description</p> <p>1 Digital Comparator 4 has generated an interrupt.</p> <p>0 No interrupt.</p> <p>This bit is cleared by writing a 1.</p>
3	DCINT3	R/W1C	0	<p>Digital Comparator 3 Interrupt Status and Clear</p> <p>Value Description</p> <p>1 Digital Comparator 3 has generated an interrupt.</p> <p>0 No interrupt.</p> <p>This bit is cleared by writing a 1.</p>
2	DCINT2	R/W1C	0	<p>Digital Comparator 2 Interrupt Status and Clear</p> <p>Value Description</p> <p>1 Digital Comparator 2 has generated an interrupt.</p> <p>0 No interrupt.</p> <p>This bit is cleared by writing a 1.</p>
1	DCINT1	R/W1C	0	<p>Digital Comparator 1 Interrupt Status and Clear</p> <p>Value Description</p> <p>1 Digital Comparator 1 has generated an interrupt.</p> <p>0 No interrupt.</p> <p>This bit is cleared by writing a 1.</p>
0	DCINT0	R/W1C	0	<p>Digital Comparator 0 Interrupt Status and Clear</p> <p>Value Description</p> <p>1 Digital Comparator 0 has generated an interrupt.</p> <p>0 No interrupt.</p> <p>This bit is cleared by writing a 1.</p>

Register 14: ADC Sample Sequence Input Multiplexer Select 0 (ADCSSMUX0), offset 0x040

This register defines the analog input configuration for each sample in a sequence executed with Sample Sequencer 0. This register is 32 bits wide and contains information for eight possible samples.

ADC Sample Sequence Input Multiplexer Select 0 (ADCSSMUX0)

ADC0 base: 0x4003.8000
 ADC1 base: 0x4003.9000
 Offset 0x040
 Type R/W, reset 0x0000.0000

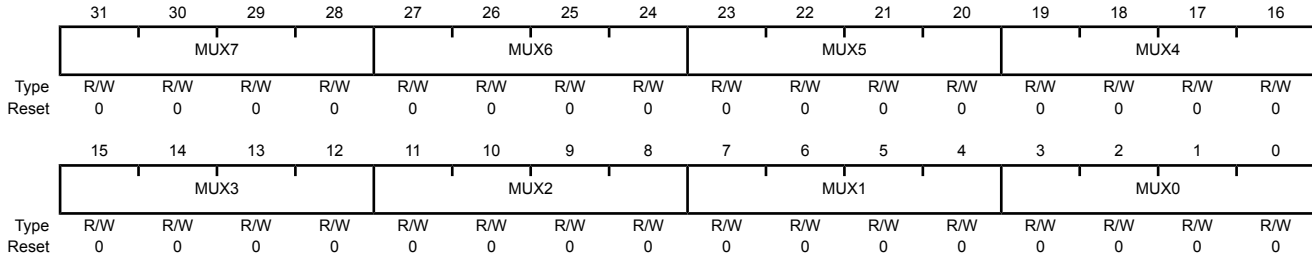

Bit/Field	Name	Type	Reset	Description
31:28	MUX7	R/W	0x0	8th Sample Input Select The MUX7 field is used during the eighth sample of a sequence executed with the sample sequencer. It specifies which of the analog inputs is sampled for the analog-to-digital conversion. The value set here indicates the corresponding pin, for example, a value of 0x1 indicates the input is AIN1.
27:24	MUX6	R/W	0x0	7th Sample Input Select The MUX6 field is used during the seventh sample of a sequence executed with the sample sequencer. It specifies which of the analog inputs is sampled for the analog-to-digital conversion.
23:20	MUX5	R/W	0x0	6th Sample Input Select The MUX5 field is used during the sixth sample of a sequence executed with the sample sequencer. It specifies which of the analog inputs is sampled for the analog-to-digital conversion.
19:16	MUX4	R/W	0x0	5th Sample Input Select The MUX4 field is used during the fifth sample of a sequence executed with the sample sequencer. It specifies which of the analog inputs is sampled for the analog-to-digital conversion.
15:12	MUX3	R/W	0x0	4th Sample Input Select The MUX3 field is used during the fourth sample of a sequence executed with the sample sequencer. It specifies which of the analog inputs is sampled for the analog-to-digital conversion.
11:8	MUX2	R/W	0x0	3rd Sample Input Select The MUX2 field is used during the third sample of a sequence executed with the sample sequencer. It specifies which of the analog inputs is sampled for the analog-to-digital conversion.

Bit/Field	Name	Type	Reset	Description
7:4	MUX1	R/W	0x0	2nd Sample Input Select The MUX1 field is used during the second sample of a sequence executed with the sample sequencer. It specifies which of the analog inputs is sampled for the analog-to-digital conversion.
3:0	MUX0	R/W	0x0	1st Sample Input Select The MUX0 field is used during the first sample of a sequence executed with the sample sequencer. It specifies which of the analog inputs is sampled for the analog-to-digital conversion.

Register 15: ADC Sample Sequence Control 0 (ADCSSCTL0), offset 0x044

This register contains the configuration information for each sample for a sequence executed with a sample sequencer. When configuring a sample sequence, the `END` bit must be set for the final sample, whether it be after the first sample, eighth sample, or any sample in between. This register is 32 bits wide and contains information for eight possible samples.

ADC Sample Sequence Control 0 (ADCSSCTL0)

ADC0 base: 0x4003.8000
 ADC1 base: 0x4003.9000
 Offset 0x044
 Type R/W, reset 0x0000.0000

	31	30	29	28	27	26	25	24	23	22	21	20	19	18	17	16
	TS7	IE7	END7	D7	TS6	IE6	END6	D6	TS5	IE5	END5	D5	TS4	IE4	END4	D4
Type	R/W	R/W	R/W	R/W	R/W	R/W	R/W	R/W	R/W	R/W	R/W	R/W	R/W	R/W	R/W	R/W
Reset	0	0	0	0	0	0	0	0	0	0	0	0	0	0	0	0
	15	14	13	12	11	10	9	8	7	6	5	4	3	2	1	0
	TS3	IE3	END3	D3	TS2	IE2	END2	D2	TS1	IE1	END1	D1	TS0	IE0	END0	D0
Type	R/W	R/W	R/W	R/W	R/W	R/W	R/W	R/W	R/W	R/W	R/W	R/W	R/W	R/W	R/W	R/W
Reset	0	0	0	0	0	0	0	0	0	0	0	0	0	0	0	0

Bit/Field	Name	Type	Reset	Description
31	TS7	R/W	0	8th Sample Temp Sensor Select
				Value Description
				1 The temperature sensor is read during the eighth sample of the sample sequence.
				0 The input pin specified by the ADCSSMUXn register is read during the eighth sample of the sample sequence.
30	IE7	R/W	0	8th Sample Interrupt Enable
				Value Description
				1 The raw interrupt signal (<code>INR0</code> bit) is asserted at the end of the eighth sample's conversion. If the <code>MASK0</code> bit in the ADCIM register is set, the interrupt is promoted to the interrupt controller.
				0 The raw interrupt is not asserted to the interrupt controller.
				It is legal to have multiple samples within a sequence generate interrupts.
29	END7	R/W	0	8th Sample is End of Sequence
				Value Description
				1 The eighth sample is the last sample of the sequence.
				0 Another sample in the sequence is the final sample.
				It is possible to end the sequence on any sample position. Software must set an <code>ENDn</code> bit somewhere within the sequence. Samples defined after the sample containing a set <code>ENDn</code> bit are not requested for conversion even though the fields may be non-zero.

Bit/Field	Name	Type	Reset	Description
28	D7	R/W	0	8th Sample Diff Input Select Value Description 1 The analog input is differentially sampled. The corresponding ADCSSMUXn nibble must be set to the pair number "i", where the paired inputs are "2i and 2i+1". 0 The analog inputs are not differentially sampled. Because the temperature sensor does not have a differential option, this bit must not be set when the TS7 bit is set.
27	TS6	R/W	0	7th Sample Temp Sensor Select Same definition as TS7 but used during the seventh sample.
26	IE6	R/W	0	7th Sample Interrupt Enable Same definition as IE7 but used during the seventh sample.
25	END6	R/W	0	7th Sample is End of Sequence Same definition as END7 but used during the seventh sample.
24	D6	R/W	0	7th Sample Diff Input Select Same definition as D7 but used during the seventh sample.
23	TS5	R/W	0	6th Sample Temp Sensor Select Same definition as TS7 but used during the sixth sample.
22	IE5	R/W	0	6th Sample Interrupt Enable Same definition as IE7 but used during the sixth sample.
21	END5	R/W	0	6th Sample is End of Sequence Same definition as END7 but used during the sixth sample.
20	D5	R/W	0	6th Sample Diff Input Select Same definition as D7 but used during the sixth sample.
19	TS4	R/W	0	5th Sample Temp Sensor Select Same definition as TS7 but used during the fifth sample.
18	IE4	R/W	0	5th Sample Interrupt Enable Same definition as IE7 but used during the fifth sample.
17	END4	R/W	0	5th Sample is End of Sequence Same definition as END7 but used during the fifth sample.
16	D4	R/W	0	5th Sample Diff Input Select Same definition as D7 but used during the fifth sample.
15	TS3	R/W	0	4th Sample Temp Sensor Select Same definition as TS7 but used during the fourth sample.
14	IE3	R/W	0	4th Sample Interrupt Enable Same definition as IE7 but used during the fourth sample.

Bit/Field	Name	Type	Reset	Description
13	END3	R/W	0	4th Sample is End of Sequence Same definition as END7 but used during the fourth sample.
12	D3	R/W	0	4th Sample Diff Input Select Same definition as D7 but used during the fourth sample.
11	TS2	R/W	0	3rd Sample Temp Sensor Select Same definition as TS7 but used during the third sample.
10	IE2	R/W	0	3rd Sample Interrupt Enable Same definition as IE7 but used during the third sample.
9	END2	R/W	0	3rd Sample is End of Sequence Same definition as END7 but used during the third sample.
8	D2	R/W	0	3rd Sample Diff Input Select Same definition as D7 but used during the third sample.
7	TS1	R/W	0	2nd Sample Temp Sensor Select Same definition as TS7 but used during the second sample.
6	IE1	R/W	0	2nd Sample Interrupt Enable Same definition as IE7 but used during the second sample.
5	END1	R/W	0	2nd Sample is End of Sequence Same definition as END7 but used during the second sample.
4	D1	R/W	0	2nd Sample Diff Input Select Same definition as D7 but used during the second sample.
3	TS0	R/W	0	1st Sample Temp Sensor Select Same definition as TS7 but used during the first sample.
2	IE0	R/W	0	1st Sample Interrupt Enable Same definition as IE7 but used during the first sample.
1	END0	R/W	0	1st Sample is End of Sequence Same definition as END7 but used during the first sample.
0	D0	R/W	0	1st Sample Diff Input Select Same definition as D7 but used during the first sample.

Register 16: ADC Sample Sequence Result FIFO 0 (ADCSSFIFO0), offset 0x048

Register 17: ADC Sample Sequence Result FIFO 1 (ADCSSFIFO1), offset 0x068

Register 18: ADC Sample Sequence Result FIFO 2 (ADCSSFIFO2), offset 0x088

Register 19: ADC Sample Sequence Result FIFO 3 (ADCSSFIFO3), offset 0x0A8

Important: This register is read-sensitive. See the register description for details.

This register contains the conversion results for samples collected with the sample sequencer (the **ADCSSFIFO0** register is used for Sample Sequencer 0, **ADCSSFIFO1** for Sequencer 1, **ADCSSFIFO2** for Sequencer 2, and **ADCSSFIFO3** for Sequencer 3). Reads of this register return conversion result data in the order sample 0, sample 1, and so on, until the FIFO is empty. If the FIFO is not properly handled by software, overflow and underflow conditions are registered in the **ADCOSTAT** and **ADCUSTAT** registers.

ADC Sample Sequence Result FIFO n (ADCSSFIFO_n)

ADC0 base: 0x4003.8000

ADC1 base: 0x4003.9000

Offset 0x048

Type RO, reset -

	31	30	29	28	27	26	25	24	23	22	21	20	19	18	17	16
	reserved															
Type	RO	RO	RO	RO	RO	RO	RO	RO	RO	RO	RO	RO	RO	RO	RO	RO
Reset	0	0	0	0	0	0	0	0	0	0	0	0	0	0	0	0
	15	14	13	12	11	10	9	8	7	6	5	4	3	2	1	0
	reserved				DATA											
Type	RO	RO	RO	RO	RO	RO	RO	RO	RO	RO	RO	RO	RO	RO	RO	RO
Reset	0	0	0	0	-	-	-	-	-	-	-	-	-	-	-	-

Bit/Field	Name	Type	Reset	Description
31:12	reserved	RO	0x0000.0	Software should not rely on the value of a reserved bit. To provide compatibility with future products, the value of a reserved bit should be preserved across a read-modify-write operation.
11:0	DATA	RO	-	Conversion Result Data

Register 20: ADC Sample Sequence FIFO 0 Status (ADCSSFSTAT0), offset 0x04C

Register 21: ADC Sample Sequence FIFO 1 Status (ADCSSFSTAT1), offset 0x06C

Register 22: ADC Sample Sequence FIFO 2 Status (ADCSSFSTAT2), offset 0x08C

Register 23: ADC Sample Sequence FIFO 3 Status (ADCSSFSTAT3), offset 0x0AC

This register provides a window into the sample sequencer, providing full/empty status information as well as the positions of the head and tail pointers. The reset value of 0x100 indicates an empty FIFO with the head and tail pointers both pointing to index 0. The **ADCSSFSTAT0** register provides status on FIFO0, which has 8 entries; **ADCSSFSTAT1** on FIFO1, which has 4 entries; **ADCSSFSTAT2** on FIFO2, which has 4 entries; and **ADCSSFSTAT3** on FIFO3 which has a single entry.

ADC Sample Sequence FIFO n Status (ADCSSFSTATn)

ADC0 base: 0x4003.8000
 ADC1 base: 0x4003.9000
 Offset 0x04C
 Type RO, reset 0x0000.0100

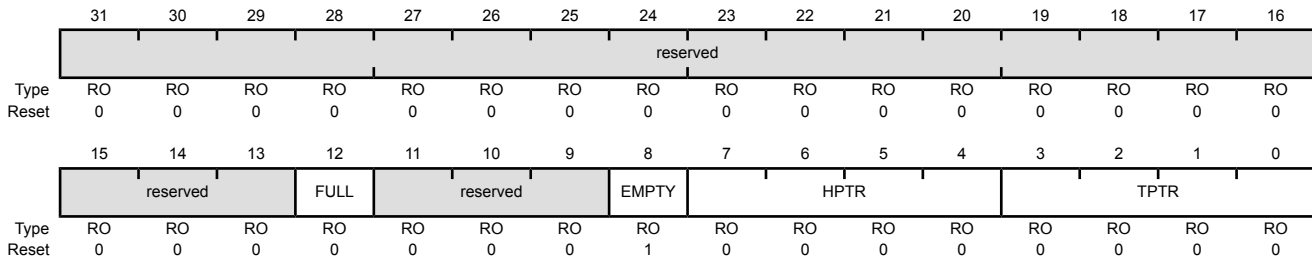

Bit/Field	Name	Type	Reset	Description
31:13	reserved	RO	0x0000.0	Software should not rely on the value of a reserved bit. To provide compatibility with future products, the value of a reserved bit should be preserved across a read-modify-write operation.
12	FULL	RO	0	FIFO Full Value Description 1 The FIFO is currently full. 0 The FIFO is not currently full.
11:9	reserved	RO	0x0	Software should not rely on the value of a reserved bit. To provide compatibility with future products, the value of a reserved bit should be preserved across a read-modify-write operation.
8	EMPTY	RO	1	FIFO Empty Value Description 1 The FIFO is currently empty. 0 The FIFO is not currently empty.

Bit/Field	Name	Type	Reset	Description
7:4	HPTR	RO	0x0	<p>FIFO Head Pointer</p> <p>This field contains the current "head" pointer index for the FIFO, that is, the next entry to be written.</p> <p>Valid values are 0x0-0x7 for FIFO0; 0x0-0x3 for FIFO1 and FIFO2; and 0x0 for FIFO3.</p>
3:0	TPTR	RO	0x0	<p>FIFO Tail Pointer</p> <p>This field contains the current "tail" pointer index for the FIFO, that is, the next entry to be read.</p> <p>Valid values are 0x0-0x7 for FIFO0; 0x0-0x3 for FIFO1 and FIFO2; and 0x0 for FIFO3.</p>

Register 24: ADC Sample Sequence 0 Operation (ADCSSOP0), offset 0x050

This register determines whether the sample from the given conversion on Sample Sequence 0 is saved in the Sample Sequence FIFO0 or sent to the digital comparator unit.

ADC Sample Sequence 0 Operation (ADCSSOP0)

ADC0 base: 0x4003.8000
 ADC1 base: 0x4003.9000
 Offset 0x050
 Type R/W, reset 0x0000.0000

	31	30	29	28	27	26	25	24	23	22	21	20	19	18	17	16
	reserved			S7DCOP	reserved			S6DCOP	reserved			S5DCOP	reserved			S4DCOP
Type	RO	RO	RO	R/W	RO	RO	RO	R/W	RO	RO	RO	R/W	RO	RO	RO	R/W
Reset	0	0	0	0	0	0	0	0	0	0	0	0	0	0	0	0
	15	14	13	12	11	10	9	8	7	6	5	4	3	2	1	0
	reserved			S3DCOP	reserved			S2DCOP	reserved			S1DCOP	reserved			S0DCOP
Type	RO	RO	RO	R/W	RO	RO	RO	R/W	RO	RO	RO	R/W	RO	RO	RO	R/W
Reset	0	0	0	0	0	0	0	0	0	0	0	0	0	0	0	0

Bit/Field	Name	Type	Reset	Description
31:29	reserved	RO	0x0	Software should not rely on the value of a reserved bit. To provide compatibility with future products, the value of a reserved bit should be preserved across a read-modify-write operation.
28	S7DCOP	R/W	0	Sample 7 Digital Comparator Operation Value Description 1 The eighth sample is sent to the digital comparator unit specified by the <i>S7DCSEL</i> bit in the ADCSSDC0 register, and the value is not written to the FIFO. 0 The eighth sample is saved in Sample Sequence FIFO0.
27:25	reserved	RO	0x0	Software should not rely on the value of a reserved bit. To provide compatibility with future products, the value of a reserved bit should be preserved across a read-modify-write operation.
24	S6DCOP	R/W	0	Sample 6 Digital Comparator Operation Same definition as <i>S7DCOP</i> but used during the seventh sample.
23:21	reserved	RO	0x0	Software should not rely on the value of a reserved bit. To provide compatibility with future products, the value of a reserved bit should be preserved across a read-modify-write operation.
20	S5DCOP	R/W	0	Sample 5 Digital Comparator Operation Same definition as <i>S7DCOP</i> but used during the sixth sample.
19:17	reserved	RO	0x0	Software should not rely on the value of a reserved bit. To provide compatibility with future products, the value of a reserved bit should be preserved across a read-modify-write operation.
16	S4DCOP	R/W	0	Sample 4 Digital Comparator Operation Same definition as <i>S7DCOP</i> but used during the fifth sample.
15:13	reserved	RO	0x0	Software should not rely on the value of a reserved bit. To provide compatibility with future products, the value of a reserved bit should be preserved across a read-modify-write operation.

Bit/Field	Name	Type	Reset	Description
12	S3DCOP	R/W	0	Sample 3 Digital Comparator Operation Same definition as S7DCOP but used during the fourth sample.
11:9	reserved	RO	0x0	Software should not rely on the value of a reserved bit. To provide compatibility with future products, the value of a reserved bit should be preserved across a read-modify-write operation.
8	S2DCOP	R/W	0	Sample 2 Digital Comparator Operation Same definition as S7DCOP but used during the third sample.
7:5	reserved	RO	0x0	Software should not rely on the value of a reserved bit. To provide compatibility with future products, the value of a reserved bit should be preserved across a read-modify-write operation.
4	S1DCOP	R/W	0	Sample 1 Digital Comparator Operation Same definition as S7DCOP but used during the second sample.
3:1	reserved	RO	0x0	Software should not rely on the value of a reserved bit. To provide compatibility with future products, the value of a reserved bit should be preserved across a read-modify-write operation.
0	S0DCOP	R/W	0	Sample 0 Digital Comparator Operation Same definition as S7DCOP but used during the first sample.

Register 25: ADC Sample Sequence 0 Digital Comparator Select (ADCSSDC0), offset 0x054

This register determines which digital comparator receives the sample from the given conversion on Sample Sequence 0, if the corresponding S_nDCOP bit in the **ADCSSOP0** register is set.

ADC Sample Sequence 0 Digital Comparator Select (ADCSSDC0)

ADC0 base: 0x4003.8000
 ADC1 base: 0x4003.9000
 Offset 0x054
 Type R/W, reset 0x0000.0000

	31	30	29	28	27	26	25	24	23	22	21	20	19	18	17	16
	S7DCSEL				S6DCSEL				S5DCSEL				S4DCSEL			
Type	R/W	R/W	R/W	R/W	R/W	R/W	R/W	R/W	R/W	R/W	R/W	R/W	R/W	R/W	R/W	R/W
Reset	0	0	0	0	0	0	0	0	0	0	0	0	0	0	0	0
	15	14	13	12	11	10	9	8	7	6	5	4	3	2	1	0
	S3DCSEL				S2DCSEL				S1DCSEL				S0DCSEL			
Type	R/W	R/W	R/W	R/W	R/W	R/W	R/W	R/W	R/W	R/W	R/W	R/W	R/W	R/W	R/W	R/W
Reset	0	0	0	0	0	0	0	0	0	0	0	0	0	0	0	0

Bit/Field	Name	Type	Reset	Description																		
31:28	S7DCSEL	R/W	0x0	<p>Sample 7 Digital Comparator Select</p> <p>When the $S7DCOP$ bit in the ADCSSOP0 register is set, this field indicates which digital comparator unit (and its associated set of control registers) receives the eighth sample from Sample Sequencer 0.</p> <p>Note: Values not listed are reserved.</p> <table border="0"> <tr> <td>Value</td> <td>Description</td> </tr> <tr> <td>0x0</td> <td>Digital Comparator Unit 0 (ADCDCCMP0 and ADCDCCTL0)</td> </tr> <tr> <td>0x1</td> <td>Digital Comparator Unit 1 (ADCDCCMP1 and ADCDCCTL1)</td> </tr> <tr> <td>0x2</td> <td>Digital Comparator Unit 2 (ADCDCCMP2 and ADCDCCTL2)</td> </tr> <tr> <td>0x3</td> <td>Digital Comparator Unit 3 (ADCDCCMP3 and ADCDCCTL3)</td> </tr> <tr> <td>0x4</td> <td>Digital Comparator Unit 4 (ADCDCCMP4 and ADCDCCTL4)</td> </tr> <tr> <td>0x5</td> <td>Digital Comparator Unit 5 (ADCDCCMP5 and ADCDCCTL5)</td> </tr> <tr> <td>0x6</td> <td>Digital Comparator Unit 6 (ADCDCCMP6 and ADCDCCTL6)</td> </tr> <tr> <td>0x7</td> <td>Digital Comparator Unit 7 (ADCDCCMP7 and ADCDCCTL7)</td> </tr> </table>	Value	Description	0x0	Digital Comparator Unit 0 (ADCDCCMP0 and ADCDCCTL0)	0x1	Digital Comparator Unit 1 (ADCDCCMP1 and ADCDCCTL1)	0x2	Digital Comparator Unit 2 (ADCDCCMP2 and ADCDCCTL2)	0x3	Digital Comparator Unit 3 (ADCDCCMP3 and ADCDCCTL3)	0x4	Digital Comparator Unit 4 (ADCDCCMP4 and ADCDCCTL4)	0x5	Digital Comparator Unit 5 (ADCDCCMP5 and ADCDCCTL5)	0x6	Digital Comparator Unit 6 (ADCDCCMP6 and ADCDCCTL6)	0x7	Digital Comparator Unit 7 (ADCDCCMP7 and ADCDCCTL7)
Value	Description																					
0x0	Digital Comparator Unit 0 (ADCDCCMP0 and ADCDCCTL0)																					
0x1	Digital Comparator Unit 1 (ADCDCCMP1 and ADCDCCTL1)																					
0x2	Digital Comparator Unit 2 (ADCDCCMP2 and ADCDCCTL2)																					
0x3	Digital Comparator Unit 3 (ADCDCCMP3 and ADCDCCTL3)																					
0x4	Digital Comparator Unit 4 (ADCDCCMP4 and ADCDCCTL4)																					
0x5	Digital Comparator Unit 5 (ADCDCCMP5 and ADCDCCTL5)																					
0x6	Digital Comparator Unit 6 (ADCDCCMP6 and ADCDCCTL6)																					
0x7	Digital Comparator Unit 7 (ADCDCCMP7 and ADCDCCTL7)																					
27:24	S6DCSEL	R/W	0x0	<p>Sample 6 Digital Comparator Select</p> <p>This field has the same encodings as $S7DCSEL$ but is used during the seventh sample.</p>																		
23:20	S5DCSEL	R/W	0x0	<p>Sample 5 Digital Comparator Select</p> <p>This field has the same encodings as $S7DCSEL$ but is used during the sixth sample.</p>																		
19:16	S4DCSEL	R/W	0x0	<p>Sample 4 Digital Comparator Select</p> <p>This field has the same encodings as $S7DCSEL$ but is used during the fifth sample.</p>																		
15:12	S3DCSEL	R/W	0x0	<p>Sample 3 Digital Comparator Select</p> <p>This field has the same encodings as $S7DCSEL$ but is used during the fourth sample.</p>																		

Bit/Field	Name	Type	Reset	Description
11:8	S2DCSEL	R/W	0x0	Sample 2 Digital Comparator Select This field has the same encodings as S7DCSEL but is used during the third sample.
7:4	S1DCSEL	R/W	0x0	Sample 1 Digital Comparator Select This field has the same encodings as S7DCSEL but is used during the second sample.
3:0	S0DCSEL	R/W	0x0	Sample 0 Digital Comparator Select This field has the same encodings as S7DCSEL but is used during the first sample.

Register 26: ADC Sample Sequence Input Multiplexer Select 1 (ADCSSMUX1), offset 0x060

Register 27: ADC Sample Sequence Input Multiplexer Select 2 (ADCSSMUX2), offset 0x080

This register defines the analog input configuration for each sample in a sequence executed with Sample Sequencer 1 or 2. These registers are 16 bits wide and contain information for four possible samples. See the **ADCSSMUX0** register on page 820 for detailed bit descriptions. The **ADCSSMUX1** register affects Sample Sequencer 1 and the **ADCSSMUX2** register affects Sample Sequencer 2.

ADC Sample Sequence Input Multiplexer Select n (ADCSSMUXn)

ADC0 base: 0x4003.8000
 ADC1 base: 0x4003.9000
 Offset 0x060
 Type R/W, reset 0x0000.0000

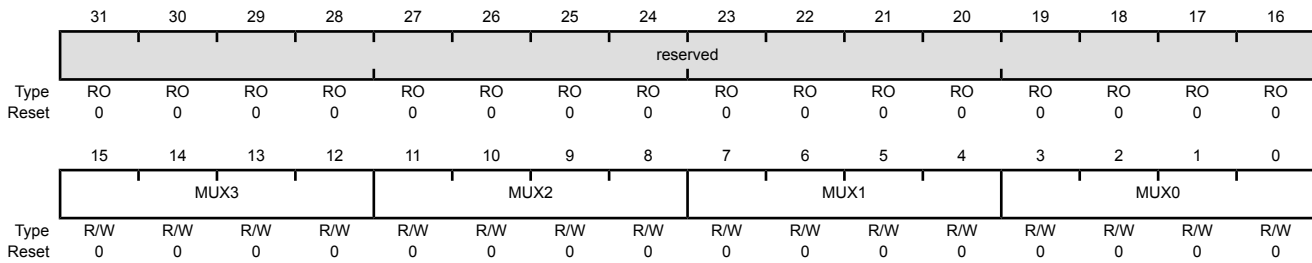

Bit/Field	Name	Type	Reset	Description
31:16	reserved	RO	0x0000	Software should not rely on the value of a reserved bit. To provide compatibility with future products, the value of a reserved bit should be preserved across a read-modify-write operation.
15:12	MUX3	R/W	0x0	4th Sample Input Select
11:8	MUX2	R/W	0x0	3rd Sample Input Select
7:4	MUX1	R/W	0x0	2nd Sample Input Select
3:0	MUX0	R/W	0x0	1st Sample Input Select

Register 28: ADC Sample Sequence Control 1 (ADCSSCTL1), offset 0x064**Register 29: ADC Sample Sequence Control 2 (ADCSSCTL2), offset 0x084**

These registers contain the configuration information for each sample for a sequence executed with Sample Sequencer 1 or 2. When configuring a sample sequence, the **END** bit must be set for the final sample, whether it be after the first sample, fourth sample, or any sample in between. These registers are 16-bits wide and contain information for four possible samples. See the **ADCSSCTL0** register on page 822 for detailed bit descriptions. The **ADCSSCTL1** register configures Sample Sequencer 1 and the **ADCSSCTL2** register configures Sample Sequencer 2.

ADC Sample Sequence Control n (ADCSSCTLn)

ADC0 base: 0x4003.8000

ADC1 base: 0x4003.9000

Offset 0x064

Type R/W, reset 0x0000.0000

	31	30	29	28	27	26	25	24	23	22	21	20	19	18	17	16
	reserved															
Type	RO	RO	RO	RO	RO	RO	RO	RO	RO	RO	RO	RO	RO	RO	RO	RO
Reset	0	0	0	0	0	0	0	0	0	0	0	0	0	0	0	0
	15	14	13	12	11	10	9	8	7	6	5	4	3	2	1	0
	TS3	IE3	END3	D3	TS2	IE2	END2	D2	TS1	IE1	END1	D1	TS0	IE0	END0	D0
Type	R/W	R/W	R/W	R/W	R/W	R/W	R/W	R/W	R/W	R/W	R/W	R/W	R/W	R/W	R/W	R/W
Reset	0	0	0	0	0	0	0	0	0	0	0	0	0	0	0	0

Bit/Field	Name	Type	Reset	Description
31:16	reserved	RO	0x0000	Software should not rely on the value of a reserved bit. To provide compatibility with future products, the value of a reserved bit should be preserved across a read-modify-write operation.
15	TS3	R/W	0	4th Sample Temp Sensor Select Same definition as TS7 but used during the fourth sample.
14	IE3	R/W	0	4th Sample Interrupt Enable Same definition as IE7 but used during the fourth sample.
13	END3	R/W	0	4th Sample is End of Sequence Same definition as END7 but used during the fourth sample.
12	D3	R/W	0	4th Sample Diff Input Select Same definition as D7 but used during the fourth sample.
11	TS2	R/W	0	3rd Sample Temp Sensor Select Same definition as TS7 but used during the third sample.
10	IE2	R/W	0	3rd Sample Interrupt Enable Same definition as IE7 but used during the third sample.
9	END2	R/W	0	3rd Sample is End of Sequence Same definition as END7 but used during the third sample.
8	D2	R/W	0	3rd Sample Diff Input Select Same definition as D7 but used during the third sample.

Bit/Field	Name	Type	Reset	Description
7	TS1	R/W	0	2nd Sample Temp Sensor Select Same definition as TS7 but used during the second sample.
6	IE1	R/W	0	2nd Sample Interrupt Enable Same definition as IE7 but used during the second sample.
5	END1	R/W	0	2nd Sample is End of Sequence Same definition as END7 but used during the second sample.
4	D1	R/W	0	2nd Sample Diff Input Select Same definition as D7 but used during the second sample.
3	TS0	R/W	0	1st Sample Temp Sensor Select Same definition as TS7 but used during the first sample.
2	IE0	R/W	0	1st Sample Interrupt Enable Same definition as IE7 but used during the first sample.
1	END0	R/W	0	1st Sample is End of Sequence Same definition as END7 but used during the first sample.
0	D0	R/W	0	1st Sample Diff Input Select Same definition as D7 but used during the first sample.

Register 30: ADC Sample Sequence 1 Operation (ADCSSOP1), offset 0x070**Register 31: ADC Sample Sequence 2 Operation (ADCSSOP2), offset 0x090**

This register determines whether the sample from the given conversion on Sample Sequence n is saved in the Sample Sequence n FIFO or sent to the digital comparator unit. The **ADCSSOP1** register controls Sample Sequencer 1 and the **ADCSSOP2** register controls Sample Sequencer 2.

ADC Sample Sequence n Operation (ADCSSOPn)

ADC0 base: 0x4003.8000

ADC1 base: 0x4003.9000

Offset 0x070

Type R/W, reset 0x0000.0000

	31	30	29	28	27	26	25	24	23	22	21	20	19	18	17	16
	reserved															
Type	RO	RO	RO	RO	RO	RO	RO	RO	RO	RO	RO	RO	RO	RO	RO	RO
Reset	0	0	0	0	0	0	0	0	0	0	0	0	0	0	0	0
	15	14	13	12	11	10	9	8	7	6	5	4	3	2	1	0
	reserved			S3DCOP	reserved			S2DCOP	reserved			S1DCOP	reserved			S0DCOP
Type	RO	RO	RO	R/W	RO	RO	RO	R/W	RO	RO	RO	R/W	RO	RO	RO	R/W
Reset	0	0	0	0	0	0	0	0	0	0	0	0	0	0	0	0

Bit/Field	Name	Type	Reset	Description
31:13	reserved	RO	0x0000.0	Software should not rely on the value of a reserved bit. To provide compatibility with future products, the value of a reserved bit should be preserved across a read-modify-write operation.
12	S3DCOP	R/W	0	Sample 3 Digital Comparator Operation Value Description 1 The fourth sample is sent to the digital comparator unit specified by the S3DCSEL bit in the ADCSSDC0n register, and the value is not written to the FIFO. 0 The fourth sample is saved in Sample Sequence FIFO.
11:9	reserved	RO	0x0	Software should not rely on the value of a reserved bit. To provide compatibility with future products, the value of a reserved bit should be preserved across a read-modify-write operation.
8	S2DCOP	R/W	0	Sample 2 Digital Comparator Operation Same definition as S3DCOP but used during the third sample.
7:5	reserved	RO	0x0	Software should not rely on the value of a reserved bit. To provide compatibility with future products, the value of a reserved bit should be preserved across a read-modify-write operation.
4	S1DCOP	R/W	0	Sample 1 Digital Comparator Operation Same definition as S3DCOP but used during the second sample.
3:1	reserved	RO	0x0	Software should not rely on the value of a reserved bit. To provide compatibility with future products, the value of a reserved bit should be preserved across a read-modify-write operation.
0	S0DCOP	R/W	0	Sample 0 Digital Comparator Operation Same definition as S3DCOP but used during the first sample.

Register 32: ADC Sample Sequence 1 Digital Comparator Select (ADCSSDC1), offset 0x074

Register 33: ADC Sample Sequence 2 Digital Comparator Select (ADCSSDC2), offset 0x094

These registers determine which digital comparator receives the sample from the given conversion on Sample Sequence n if the corresponding S_nDCOP bit in the **ADCSSOPn** register is set. The **ADCSSDC1** register controls the selection for Sample Sequencer 1 and the **ADCSSDC2** register controls the selection for Sample Sequencer 2.

ADC Sample Sequence n Digital Comparator Select (ADCSSDCn)

ADC0 base: 0x4003.8000
 ADC1 base: 0x4003.9000
 Offset 0x074
 Type R/W, reset 0x0000.0000

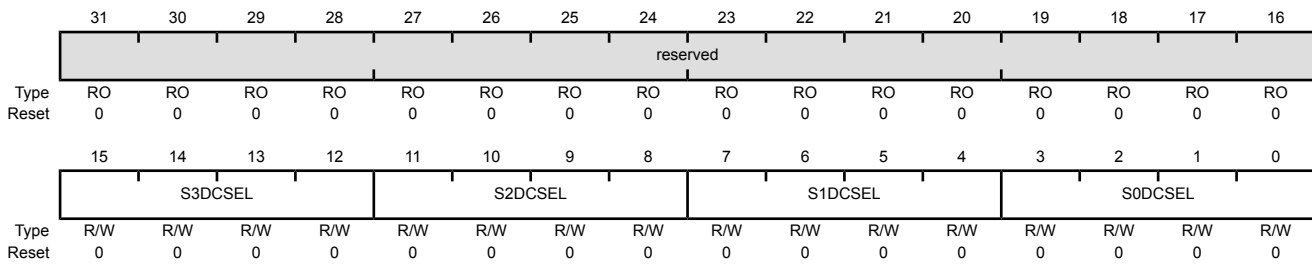

Bit/Field	Name	Type	Reset	Description
31:16	reserved	RO	0x0000	Software should not rely on the value of a reserved bit. To provide compatibility with future products, the value of a reserved bit should be preserved across a read-modify-write operation.
15:12	S3DCSEL	R/W	0x0	<p>Sample 3 Digital Comparator Select</p> <p>When the $S3DCOP$ bit in the ADCSSOPn register is set, this field indicates which digital comparator unit (and its associated set of control registers) receives the eighth sample from Sample Sequencer n.</p> <p>Note: Values not listed are reserved.</p> <p>Value Description</p> <p>0x0 Digital Comparator Unit 0 (ADCDCOMP0 and ADCCCTL0)</p> <p>0x1 Digital Comparator Unit 1 (ADCDCOMP1 and ADCCCTL1)</p> <p>0x2 Digital Comparator Unit 2 (ADCDCOMP2 and ADCCCTL2)</p> <p>0x3 Digital Comparator Unit 3 (ADCDCOMP3 and ADCCCTL3)</p> <p>0x4 Digital Comparator Unit 4 (ADCDCOMP4 and ADCCCTL4)</p> <p>0x5 Digital Comparator Unit 5 (ADCDCOMP5 and ADCCCTL5)</p> <p>0x6 Digital Comparator Unit 6 (ADCDCOMP6 and ADCCCTL6)</p> <p>0x7 Digital Comparator Unit 7 (ADCDCOMP7 and ADCCCTL7)</p>
11:8	S2DCSEL	R/W	0x0	<p>Sample 2 Digital Comparator Select</p> <p>This field has the same encodings as S3DCSEL but is used during the third sample.</p>

Bit/Field	Name	Type	Reset	Description
7:4	S1DCSEL	R/W	0x0	Sample 1 Digital Comparator Select This field has the same encodings as S3DCSEL but is used during the second sample.
3:0	S0DCSEL	R/W	0x0	Sample 0 Digital Comparator Select This field has the same encodings as S3DCSEL but is used during the first sample.

Register 34: ADC Sample Sequence Input Multiplexer Select 3 (ADCSSMUX3), offset 0x0A0

This register defines the analog input configuration for the sample executed with Sample Sequencer 3. This register is 4 bits wide and contains information for one possible sample. See the **ADCSSMUX0** register on page 820 for detailed bit descriptions.

ADC Sample Sequence Input Multiplexer Select 3 (ADCSSMUX3)

ADC0 base: 0x4003.8000
 ADC1 base: 0x4003.9000
 Offset 0x0A0
 Type R/W, reset 0x0000.0000

	31	30	29	28	27	26	25	24	23	22	21	20	19	18	17	16
	reserved															
Type	RO	RO	RO	RO	RO	RO	RO	RO	RO	RO	RO	RO	RO	RO	RO	RO
Reset	0	0	0	0	0	0	0	0	0	0	0	0	0	0	0	0
	15	14	13	12	11	10	9	8	7	6	5	4	3	2	1	0
	reserved												MUX0			
Type	RO	RO	RO	RO	RO	RO	RO	RO	RO	RO	RO	RO	R/W	R/W	R/W	R/W
Reset	0	0	0	0	0	0	0	0	0	0	0	0	0	0	0	0

Bit/Field	Name	Type	Reset	Description
31:4	reserved	RO	0x0000.000	Software should not rely on the value of a reserved bit. To provide compatibility with future products, the value of a reserved bit should be preserved across a read-modify-write operation.
3:0	MUX0	R/W	0	1st Sample Input Select

Register 35: ADC Sample Sequence Control 3 (ADCSSCTL3), offset 0x0A4

This register contains the configuration information for a sample executed with Sample Sequencer 3. This register is 4 bits wide and contains information for one possible sample. See the **ADCSSCTL0** register on page 822 for detailed bit descriptions.

ADC Sample Sequence Control 3 (ADCSSCTL3)

ADC0 base: 0x4003.8000
 ADC1 base: 0x4003.9000
 Offset 0x0A4
 Type R/W, reset 0x0000.0000

	31	30	29	28	27	26	25	24	23	22	21	20	19	18	17	16	
	reserved																
Type	RO	RO	RO	RO	RO	RO	RO	RO	RO	RO	RO	RO	RO	RO	RO	RO	
Reset	0	0	0	0	0	0	0	0	0	0	0	0	0	0	0	0	
	15	14	13	12	11	10	9	8	7	6	5	4	3	2	1	0	
	reserved												TS0	IE0	END0	D0	
Type	RO	RO	RO	RO	RO	RO	RO	RO	RO	RO	RO	RO	RO	R/W	R/W	R/W	R/W
Reset	0	0	0	0	0	0	0	0	0	0	0	0	0	0	0	0	0

Bit/Field	Name	Type	Reset	Description
31:4	reserved	RO	0x0000.000	Software should not rely on the value of a reserved bit. To provide compatibility with future products, the value of a reserved bit should be preserved across a read-modify-write operation.
3	TS0	R/W	0	1st Sample Temp Sensor Select Same definition as TS7 but used during the first sample.
2	IE0	R/W	0	1st Sample Interrupt Enable Same definition as IE7 but used during the first sample.
1	END0	R/W	0	1st Sample is End of Sequence Same definition as END7 but used during the first sample.
0	D0	R/W	0	1st Sample Diff Input Select Same definition as D7 but used during the first sample.

Register 36: ADC Sample Sequence 3 Operation (ADCSSOP3), offset 0x0B0

This register determines whether the sample from the given conversion on Sample Sequence 3 is saved in the Sample Sequence 3 FIFO or sent to the digital comparator unit.

ADC Sample Sequence 3 Operation (ADCSSOP3)

ADC0 base: 0x4003.8000
 ADC1 base: 0x4003.9000
 Offset 0x0B0
 Type R/W, reset 0x0000.0000

	31	30	29	28	27	26	25	24	23	22	21	20	19	18	17	16
	reserved															
Type	RO	RO	RO	RO	RO	RO	RO	RO	RO	RO	RO	RO	RO	RO	RO	RO
Reset	0	0	0	0	0	0	0	0	0	0	0	0	0	0	0	0
	15	14	13	12	11	10	9	8	7	6	5	4	3	2	1	0
	reserved															S0DCOP
Type	RO	RO	RO	RO	RO	RO	RO	RO	RO	RO	RO	RO	RO	RO	RO	R/W
Reset	0	0	0	0	0	0	0	0	0	0	0	0	0	0	0	0

Bit/Field	Name	Type	Reset	Description
31:1	reserved	RO	0x0000.000	Software should not rely on the value of a reserved bit. To provide compatibility with future products, the value of a reserved bit should be preserved across a read-modify-write operation.
0	S0DCOP	R/W	0	Sample 0 Digital Comparator Operation
				Value Description
				1 The sample is sent to the digital comparator unit specified by the S0DCSEL bit in the ADCSSDC03 register, and the value is not written to the FIFO.
				0 The sample is saved in Sample Sequence FIFO3.

Register 37: ADC Sample Sequence 3 Digital Comparator Select (ADCSSDC3), offset 0x0B4

This register determines which digital comparator receives the sample from the given conversion on Sample Sequence 3 if the corresponding S_nDCOP bit in the **ADCSSOP3** register is set.

ADC Sample Sequence 3 Digital Comparator Select (ADCSSDC3)

ADC0 base: 0x4003.8000
 ADC1 base: 0x4003.9000
 Offset 0x0B4
 Type R/W, reset 0x0000.0000

	31	30	29	28	27	26	25	24	23	22	21	20	19	18	17	16
	reserved															
Type	RO	RO	RO	RO	RO	RO	RO	RO	RO	RO	RO	RO	RO	RO	RO	RO
Reset	0	0	0	0	0	0	0	0	0	0	0	0	0	0	0	0
	15	14	13	12	11	10	9	8	7	6	5	4	3	2	1	0
	reserved												S0DCSEL			
Type	RO	RO	RO	RO	RO	RO	RO	RO	RO	RO	RO	RO	R/W	R/W	R/W	R/W
Reset	0	0	0	0	0	0	0	0	0	0	0	0	0	0	0	0

Bit/Field	Name	Type	Reset	Description
31:4	reserved	RO	0x0000.000	Software should not rely on the value of a reserved bit. To provide compatibility with future products, the value of a reserved bit should be preserved across a read-modify-write operation.
3:0	S0DCSEL	R/W	0x0	Sample 0 Digital Comparator Select When the $S0DCOP$ bit in the ADCSSOP3 register is set, this field indicates which digital comparator unit (and its associated set of control registers) receives the sample from Sample Sequencer 3.

Note: Values not listed are reserved.

Value	Description
0x0	Digital Comparator Unit 0 (ADCDCOMP0 and ADCCCTL0)
0x1	Digital Comparator Unit 1 (ADCDCOMP1 and ADCCCTL1)
0x2	Digital Comparator Unit 2 (ADCDCOMP2 and ADCCCTL2)
0x3	Digital Comparator Unit 3 (ADCDCOMP3 and ADCCCTL3)
0x4	Digital Comparator Unit 4 (ADCDCOMP4 and ADCCCTL4)
0x5	Digital Comparator Unit 5 (ADCDCOMP5 and ADCCCTL5)
0x6	Digital Comparator Unit 6 (ADCDCOMP6 and ADCCCTL6)
0x7	Digital Comparator Unit 7 (ADCDCOMP7 and ADCCCTL7)

Register 38: ADC Digital Comparator Reset Initial Conditions (ADCDRCR1C), offset 0xD00

This register provides the ability to reset any of the digital comparator interrupt or trigger functions back to their initial conditions. Resetting these functions ensures that the data that is being used by the interrupt and trigger functions in the digital comparator unit is not stale.

ADC Digital Comparator Reset Initial Conditions (ADCDRCR1C)

ADC0 base: 0x4003.8000
 ADC1 base: 0x4003.9000
 Offset 0xD00
 Type WO, reset 0x0000.0000

	31	30	29	28	27	26	25	24	23	22	21	20	19	18	17	16
	reserved								DCTRIG7	DCTRIG6	DCTRIG5	DCTRIG4	DCTRIG3	DCTRIG2	DCTRIG1	DCTRIG0
Type	RO	RO	RO	RO	RO	RO	RO	RO	WO	WO	WO	WO	WO	WO	WO	WO
Reset	0	0	0	0	0	0	0	0	0	0	0	0	0	0	0	0
	15	14	13	12	11	10	9	8	7	6	5	4	3	2	1	0
	reserved								DCINT7	DCINT6	DCINT5	DCINT4	DCINT3	DCINT2	DCINT1	DCINT0
Type	RO	RO	RO	RO	RO	RO	RO	RO	WO	WO	WO	WO	WO	WO	WO	WO
Reset	0	0	0	0	0	0	0	0	0	0	0	0	0	0	0	0

Bit/Field	Name	Type	Reset	Description
31:24	reserved	RO	0x00	Software should not rely on the value of a reserved bit. To provide compatibility with future products, the value of a reserved bit should be preserved across a read-modify-write operation.
23	DCTRIG7	WO	0	Digital Comparator Trigger 7 Value Description 1 Resets the Digital Comparator 7 trigger unit to its initial conditions. 0 No effect. When the trigger has been cleared, this bit is automatically cleared. Because the digital comparators use the current and previous ADC conversion values to determine when to assert the trigger, it is important to reset the digital comparator to initial conditions when starting a new sequence so that stale data is not used. After setting this bit, software should wait until the bit clears before continuing.
22	DCTRIG6	WO	0	Digital Comparator Trigger 6 Value Description 1 Resets the Digital Comparator 6 trigger unit to its initial conditions. 0 No effect. When the trigger has been cleared, this bit is automatically cleared. Because the digital comparators use the current and previous ADC conversion values to determine when to assert the trigger, it is important to reset the digital comparator to initial conditions when starting a new sequence so that stale data is not used.

Bit/Field	Name	Type	Reset	Description
21	DCTRIG5	WO	0	<p>Digital Comparator Trigger 5</p> <p>Value Description</p> <p>1 Resets the Digital Comparator 5 trigger unit to its initial conditions.</p> <p>0 No effect.</p> <p>When the trigger has been cleared, this bit is automatically cleared. Because the digital comparators use the current and previous ADC conversion values to determine when to assert the trigger, it is important to reset the digital comparator to initial conditions when starting a new sequence so that stale data is not used.</p>
20	DCTRIG4	WO	0	<p>Digital Comparator Trigger 4</p> <p>Value Description</p> <p>1 Resets the Digital Comparator 4 trigger unit to its initial conditions.</p> <p>0 No effect.</p> <p>When the trigger has been cleared, this bit is automatically cleared. Because the digital comparators use the current and previous ADC conversion values to determine when to assert the trigger, it is important to reset the digital comparator to initial conditions when starting a new sequence so that stale data is not used.</p>
19	DCTRIG3	WO	0	<p>Digital Comparator Trigger 3</p> <p>Value Description</p> <p>1 Resets the Digital Comparator 3 trigger unit to its initial conditions.</p> <p>0 No effect.</p> <p>When the trigger has been cleared, this bit is automatically cleared. Because the digital comparators use the current and previous ADC conversion values to determine when to assert the trigger, it is important to reset the digital comparator to initial conditions when starting a new sequence so that stale data is not used.</p>
18	DCTRIG2	WO	0	<p>Digital Comparator Trigger 2</p> <p>Value Description</p> <p>1 Resets the Digital Comparator 2 trigger unit to its initial conditions.</p> <p>0 No effect.</p> <p>When the trigger has been cleared, this bit is automatically cleared. Because the digital comparators use the current and previous ADC conversion values to determine when to assert the trigger, it is important to reset the digital comparator to initial conditions when starting a new sequence so that stale data is not used.</p>

Bit/Field	Name	Type	Reset	Description
17	DCTRIG1	WO	0	<p>Digital Comparator Trigger 1</p> <p>Value Description</p> <p>1 Resets the Digital Comparator 1 trigger unit to its initial conditions.</p> <p>0 No effect.</p> <p>When the trigger has been cleared, this bit is automatically cleared. Because the digital comparators use the current and previous ADC conversion values to determine when to assert the trigger, it is important to reset the digital comparator to initial conditions when starting a new sequence so that stale data is not used.</p>
16	DCTRIG0	WO	0	<p>Digital Comparator Trigger 0</p> <p>Value Description</p> <p>1 Resets the Digital Comparator 0 trigger unit to its initial conditions.</p> <p>0 No effect.</p> <p>When the trigger has been cleared, this bit is automatically cleared. Because the digital comparators use the current and previous ADC conversion values to determine when to assert the trigger, it is important to reset the digital comparator to initial conditions when starting a new sequence so that stale data is not used.</p>
15:8	reserved	RO	0x00	<p>Software should not rely on the value of a reserved bit. To provide compatibility with future products, the value of a reserved bit should be preserved across a read-modify-write operation.</p>
7	DCINT7	WO	0	<p>Digital Comparator Interrupt 7</p> <p>Value Description</p> <p>1 Resets the Digital Comparator 7 interrupt unit to its initial conditions.</p> <p>0 No effect.</p> <p>When the interrupt has been cleared, this bit is automatically cleared. Because the digital comparators use the current and previous ADC conversion values to determine when to assert the interrupt, it is important to reset the digital comparator to initial conditions when starting a new sequence so that stale data is not used.</p>
6	DCINT6	WO	0	<p>Digital Comparator Interrupt 6</p> <p>Value Description</p> <p>1 Resets the Digital Comparator 6 interrupt unit to its initial conditions.</p> <p>0 No effect.</p> <p>When the interrupt has been cleared, this bit is automatically cleared. Because the digital comparators use the current and previous ADC conversion values to determine when to assert the interrupt, it is important to reset the digital comparator to initial conditions when starting a new sequence so that stale data is not used.</p>

Bit/Field	Name	Type	Reset	Description
5	DCINT5	WO	0	<p>Digital Comparator Interrupt 5</p> <p>Value Description</p> <p>1 Resets the Digital Comparator 5 interrupt unit to its initial conditions.</p> <p>0 No effect.</p> <p>When the interrupt has been cleared, this bit is automatically cleared. Because the digital comparators use the current and previous ADC conversion values to determine when to assert the interrupt, it is important to reset the digital comparator to initial conditions when starting a new sequence so that stale data is not used.</p>
4	DCINT4	WO	0	<p>Digital Comparator Interrupt 4</p> <p>Value Description</p> <p>1 Resets the Digital Comparator 4 interrupt unit to its initial conditions.</p> <p>0 No effect.</p> <p>When the interrupt has been cleared, this bit is automatically cleared. Because the digital comparators use the current and previous ADC conversion values to determine when to assert the interrupt, it is important to reset the digital comparator to initial conditions when starting a new sequence so that stale data is not used.</p>
3	DCINT3	WO	0	<p>Digital Comparator Interrupt 3</p> <p>Value Description</p> <p>1 Resets the Digital Comparator 3 interrupt unit to its initial conditions.</p> <p>0 No effect.</p> <p>When the interrupt has been cleared, this bit is automatically cleared. Because the digital comparators use the current and previous ADC conversion values to determine when to assert the interrupt, it is important to reset the digital comparator to initial conditions when starting a new sequence so that stale data is not used.</p>
2	DCINT2	WO	0	<p>Digital Comparator Interrupt 2</p> <p>Value Description</p> <p>1 Resets the Digital Comparator 2 interrupt unit to its initial conditions.</p> <p>0 No effect.</p> <p>When the interrupt has been cleared, this bit is automatically cleared. Because the digital comparators use the current and previous ADC conversion values to determine when to assert the interrupt, it is important to reset the digital comparator to initial conditions when starting a new sequence so that stale data is not used.</p>

Bit/Field	Name	Type	Reset	Description
1	DCINT1	WO	0	Digital Comparator Interrupt 1 Value Description 1 Resets the Digital Comparator 1 interrupt unit to its initial conditions. 0 No effect. When the interrupt has been cleared, this bit is automatically cleared. Because the digital comparators use the current and previous ADC conversion values to determine when to assert the interrupt, it is important to reset the digital comparator to initial conditions when starting a new sequence so that stale data is not used.
0	DCINT0	WO	0	Digital Comparator Interrupt 0 Value Description 1 Resets the Digital Comparator 0 interrupt unit to its initial conditions. 0 No effect. When the interrupt has been cleared, this bit is automatically cleared. Because the digital comparators use the current and previous ADC conversion values to determine when to assert the interrupt, it is important to reset the digital comparator to initial conditions when starting a new sequence so that stale data is not used.

Register 39: ADC Digital Comparator Control 0 (ADCDCCTL0), offset 0xE00

Register 40: ADC Digital Comparator Control 1 (ADCDCCTL1), offset 0xE04

Register 41: ADC Digital Comparator Control 2 (ADCDCCTL2), offset 0xE08

Register 42: ADC Digital Comparator Control 3 (ADCDCCTL3), offset 0xE0C

Register 43: ADC Digital Comparator Control 4 (ADCDCCTL4), offset 0xE10

Register 44: ADC Digital Comparator Control 5 (ADCDCCTL5), offset 0xE14

Register 45: ADC Digital Comparator Control 6 (ADCDCCTL6), offset 0xE18

Register 46: ADC Digital Comparator Control 7 (ADCDCCTL7), offset 0xE1C

This register provides the comparison encodings that generate an interrupt and/or PWM trigger. See "Interrupt/ADC-Trigger Selector" on page 1196 for more information on using the ADC digital comparators to trigger a PWM generator.

ADC Digital Comparator Control n (ADCDCCTLn)

ADC0 base: 0x4003.8000

ADC1 base: 0x4003.9000

Offset 0xE00

Type R/W, reset 0x0000.0000

	31	30	29	28	27	26	25	24	23	22	21	20	19	18	17	16		
	reserved																	
Type	RO	RO	RO	RO	RO	RO	RO	RO	RO	RO	RO	RO	RO	RO	RO	RO		
Reset	0	0	0	0	0	0	0	0	0	0	0	0	0	0	0	0		
	15	14	13	12	11	10	9	8	7	6	5	4	3	2	1	0		
	reserved			CTE	CTC			CTM			reserved			CIE	CIC		CIM	
Type	RO	RO	RO	R/W	R/W	R/W	R/W	R/W	RO	RO	RO	R/W	R/W	R/W	R/W	R/W		
Reset	0	0	0	0	0	0	0	0	0	0	0	0	0	0	0	0		

Bit/Field	Name	Type	Reset	Description
31:13	reserved	RO	0x0000.0	Software should not rely on the value of a reserved bit. To provide compatibility with future products, the value of a reserved bit should be preserved across a read-modify-write operation.

12	CTE	R/W	0	Comparison Trigger Enable
----	-----	-----	---	---------------------------

Value Description

- | | |
|---|---|
| 1 | Enables the trigger function state machine. The ADC conversion data is used to determine if a trigger should be generated according to the programming of the CTC and CTM fields. |
| 0 | Disables the trigger function state machine. ADC conversion data is ignored by the trigger function. |

Bit/Field	Name	Type	Reset	Description										
11:10	CTC	R/W	0x0	<p>Comparison Trigger Condition</p> <p>This field specifies the operational region in which a trigger is generated when the ADC conversion data is compared against the values of COMP0 and COMP1. The COMP0 and COMP1 fields are defined in the ADCDCMPx registers.</p> <table border="1"> <thead> <tr> <th>Value</th> <th>Description</th> </tr> </thead> <tbody> <tr> <td>0x0</td> <td>Low Band ADC Data < COMP0 ≤ COMP1</td> </tr> <tr> <td>0x1</td> <td>Mid Band COMP0 ≤ ADC Data < COMP1</td> </tr> <tr> <td>0x2</td> <td>reserved</td> </tr> <tr> <td>0x3</td> <td>High Band COMP0 ≤ COMP1 ≤ ADC Data</td> </tr> </tbody> </table>	Value	Description	0x0	Low Band ADC Data < COMP0 ≤ COMP1	0x1	Mid Band COMP0 ≤ ADC Data < COMP1	0x2	reserved	0x3	High Band COMP0 ≤ COMP1 ≤ ADC Data
Value	Description													
0x0	Low Band ADC Data < COMP0 ≤ COMP1													
0x1	Mid Band COMP0 ≤ ADC Data < COMP1													
0x2	reserved													
0x3	High Band COMP0 ≤ COMP1 ≤ ADC Data													
9:8	CTM	R/W	0x0	<p>Comparison Trigger Mode</p> <p>This field specifies the mode by which the trigger comparison is made.</p> <table border="1"> <thead> <tr> <th>Value</th> <th>Description</th> </tr> </thead> <tbody> <tr> <td>0x0</td> <td>Always This mode generates a trigger every time the ADC conversion data falls within the selected operational region.</td> </tr> <tr> <td>0x1</td> <td>Once This mode generates a trigger the first time that the ADC conversion data enters the selected operational region.</td> </tr> <tr> <td>0x2</td> <td>Hysteresis Always This mode generates a trigger when the ADC conversion data falls within the selected operational region and continues to generate the trigger until the hysteresis condition is cleared by entering the opposite operational region. Note that the hysteresis modes are only defined for CTC encodings of 0x0 and 0x3.</td> </tr> <tr> <td>0x3</td> <td>Hysteresis Once This mode generates a trigger the first time that the ADC conversion data falls within the selected operational region. No additional triggers are generated until the hysteresis condition is cleared by entering the opposite operational region. Note that the hysteresis modes are only defined for CTC encodings of 0x0 and 0x3.</td> </tr> </tbody> </table>	Value	Description	0x0	Always This mode generates a trigger every time the ADC conversion data falls within the selected operational region.	0x1	Once This mode generates a trigger the first time that the ADC conversion data enters the selected operational region.	0x2	Hysteresis Always This mode generates a trigger when the ADC conversion data falls within the selected operational region and continues to generate the trigger until the hysteresis condition is cleared by entering the opposite operational region. Note that the hysteresis modes are only defined for CTC encodings of 0x0 and 0x3.	0x3	Hysteresis Once This mode generates a trigger the first time that the ADC conversion data falls within the selected operational region. No additional triggers are generated until the hysteresis condition is cleared by entering the opposite operational region. Note that the hysteresis modes are only defined for CTC encodings of 0x0 and 0x3.
Value	Description													
0x0	Always This mode generates a trigger every time the ADC conversion data falls within the selected operational region.													
0x1	Once This mode generates a trigger the first time that the ADC conversion data enters the selected operational region.													
0x2	Hysteresis Always This mode generates a trigger when the ADC conversion data falls within the selected operational region and continues to generate the trigger until the hysteresis condition is cleared by entering the opposite operational region. Note that the hysteresis modes are only defined for CTC encodings of 0x0 and 0x3.													
0x3	Hysteresis Once This mode generates a trigger the first time that the ADC conversion data falls within the selected operational region. No additional triggers are generated until the hysteresis condition is cleared by entering the opposite operational region. Note that the hysteresis modes are only defined for CTC encodings of 0x0 and 0x3.													
7:5	reserved	RO	0x0	Software should not rely on the value of a reserved bit. To provide compatibility with future products, the value of a reserved bit should be preserved across a read-modify-write operation.										

Bit/Field	Name	Type	Reset	Description
4	CIE	R/W	0	<p>Comparison Interrupt Enable</p> <p>Value Description</p> <p>1 Enables the comparison interrupt. The ADC conversion data is used to determine if an interrupt should be generated according to the programming of the CIE and CIM fields.</p> <p>0 Disables the comparison interrupt. ADC conversion data has no effect on interrupt generation.</p>
3:2	CIC	R/W	0x0	<p>Comparison Interrupt Condition</p> <p>This field specifies the operational region in which an interrupt is generated when the ADC conversion data is compared against the values of COMP0 and COMP1. The COMP0 and COMP1 fields are defined in the ADCDCCMPx registers.</p> <p>Value Description</p> <p>0x0 Low Band ADC Data < COMP0 ≤ COMP1</p> <p>0x1 Mid Band COMP0 ≤ ADC Data < COMP1</p> <p>0x2 reserved</p> <p>0x3 High Band COMP0 < COMP1 ≤ ADC Data</p>
1:0	CIM	R/W	0x0	<p>Comparison Interrupt Mode</p> <p>This field specifies the mode by which the interrupt comparison is made.</p> <p>Value Description</p> <p>0x0 Always This mode generates an interrupt every time the ADC conversion data falls within the selected operational region.</p> <p>0x1 Once This mode generates an interrupt the first time that the ADC conversion data enters the selected operational region.</p> <p>0x2 Hysteresis Always This mode generates an interrupt when the ADC conversion data falls within the selected operational region and continues to generate the interrupt until the hysteresis condition is cleared by entering the opposite operational region. Note that the hysteresis modes are only defined for CTC encodings of 0x0 and 0x3.</p> <p>0x3 Hysteresis Once This mode generates an interrupt the first time that the ADC conversion data falls within the selected operational region. No additional interrupts are generated until the hysteresis condition is cleared by entering the opposite operational region. Note that the hysteresis modes are only defined for CTC encodings of 0x0 and 0x3.</p>

Register 47: ADC Digital Comparator Range 0 (ADCDCMP0), offset 0xE40

Register 48: ADC Digital Comparator Range 1 (ADCDCMP1), offset 0xE44

Register 49: ADC Digital Comparator Range 2 (ADCDCMP2), offset 0xE48

Register 50: ADC Digital Comparator Range 3 (ADCDCMP3), offset 0xE4C

Register 51: ADC Digital Comparator Range 4 (ADCDCMP4), offset 0xE50

Register 52: ADC Digital Comparator Range 5 (ADCDCMP5), offset 0xE54

Register 53: ADC Digital Comparator Range 6 (ADCDCMP6), offset 0xE58

Register 54: ADC Digital Comparator Range 7 (ADCDCMP7), offset 0xE5C

This register defines the comparison values that are used to determine if the ADC conversion data falls in the appropriate operating region.

Note: The value in the COMP1 field must be greater than or equal to the value in the COMP0 field or unexpected results can occur.

ADC Digital Comparator Range n (ADCDCMPn)

ADC0 base: 0x4003.8000
 ADC1 base: 0x4003.9000
 Offset 0xE40
 Type R/W, reset 0x0000.0000

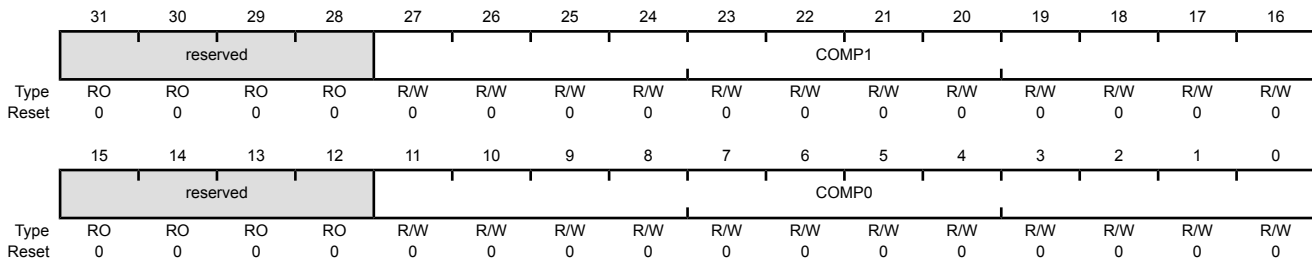

Bit/Field	Name	Type	Reset	Description
31:28	reserved	RO	0x0	Software should not rely on the value of a reserved bit. To provide compatibility with future products, the value of a reserved bit should be preserved across a read-modify-write operation.
27:16	COMP1	R/W	0x000	Compare 1 The value in this field is compared against the ADC conversion data. The result of the comparison is used to determine if the data lies within the high-band region. Note that the value of COMP1 must be greater than or equal to the value of COMP0.
15:12	reserved	RO	0x0	Software should not rely on the value of a reserved bit. To provide compatibility with future products, the value of a reserved bit should be preserved across a read-modify-write operation.
11:0	COMP0	R/W	0x000	Compare 0 The value in this field is compared against the ADC conversion data. The result of the comparison is used to determine if the data lies within the low-band region.

Register 55: ADC Peripheral Properties (ADCPP), offset 0xFC0

The **ADCPP** register provides information regarding the properties of the ADC module.

ADC Peripheral Properties (ADCPP)

ADC0 base: 0x4003.8000
 ADC1 base: 0x4003.9000
 Offset 0xFC0
 Type RO, reset 0x00B0.20C7

	31	30	29	28	27	26	25	24	23	22	21	20	19	18	17	16	
	reserved								TS	RSL				TYPE			
Type	RO	RO	RO	RO	RO	RO	RO	RO	RO	RO	RO	RO	RO	RO	RO	RO	RO
Reset	0	0	0	0	0	0	0	0	1	0	1	1	0	0	0	0	0
	15	14	13	12	11	10	9	8	7	6	5	4	3	2	1	0	
	DC				CH						MSR						
Type	RO	RO	RO	RO	RO	RO	RO	RO	RO	RO	RO	RO	RO	RO	RO	RO	RO
Reset	0	0	1	0	0	0	0	0	1	1	0	0	0	0	1	1	1

Bit/Field	Name	Type	Reset	Description
31:24	reserved	RO	0	Software should not rely on the value of a reserved bit. To provide compatibility with future products, the value of a reserved bit should be preserved across a read-modify-write operation.
23	TS	RO	0x1	Temperature Sensor Value Description 1 The ADC module has a temperature sensor. 0 The ADC module does not have a temperature sensor. This field provides the similar information as the legacy DC1 register TEMPSNS bit.
22:18	RSL	RO	0xC	Resolution This field specifies the maximum number of binary bits used to represent the converted sample. The field is encoded as a binary value, in the range of 0 to 32 bits.
17:16	TYPE	RO	0x0	ADC Architecture Value Description 0x0 SAR 0x1 - 0x3 Reserved
15:10	DC	RO	0x8	Digital Comparator Count This field specifies the number of ADC digital comparators available to the converter. The field is encoded as a binary value, in the range of 0 to 63. This field provides similar information to the legacy DC9 register ADCnDCn bits.

Bit/Field	Name	Type	Reset	Description																				
9:4	CH	RO	0xC	<p>ADC Channel Count</p> <p>This field specifies the number of ADC input channels available to the converter. This field is encoded as a binary value, in the range of 0 to 63.</p> <p>This field provides similar information to the legacy DC3 and DC8 register ADCnAINn bits.</p>																				
3:0	MSR	RO	0x7	<p>Maximum ADC Sample Rate</p> <p>This field specifies the maximum number of ADC conversions per second. The MSR field is encoded as follows:</p> <table border="1"><thead><tr><th>Value</th><th>Description</th></tr></thead><tbody><tr><td>0x0</td><td>Reserved</td></tr><tr><td>0x1</td><td>125 ksps</td></tr><tr><td>0x2</td><td>Reserved</td></tr><tr><td>0x3</td><td>250 ksps</td></tr><tr><td>0x4</td><td>Reserved</td></tr><tr><td>0x5</td><td>500 ksps</td></tr><tr><td>0x6</td><td>Reserved</td></tr><tr><td>0x7</td><td>1 Msps</td></tr><tr><td>0x8 - 0xF</td><td>Reserved</td></tr></tbody></table>	Value	Description	0x0	Reserved	0x1	125 ksps	0x2	Reserved	0x3	250 ksps	0x4	Reserved	0x5	500 ksps	0x6	Reserved	0x7	1 Msps	0x8 - 0xF	Reserved
Value	Description																							
0x0	Reserved																							
0x1	125 ksps																							
0x2	Reserved																							
0x3	250 ksps																							
0x4	Reserved																							
0x5	500 ksps																							
0x6	Reserved																							
0x7	1 Msps																							
0x8 - 0xF	Reserved																							

Register 56: ADC Peripheral Configuration (ADCPC), offset 0xFC4

The **ADCPC** register provides information regarding the configuration of the peripheral.

ADC Peripheral Configuration (ADCPC)

ADC0 base: 0x4003.8000

ADC1 base: 0x4003.9000

Offset 0xFC4

Type R/W, reset 0x0000.0007

	31	30	29	28	27	26	25	24	23	22	21	20	19	18	17	16
	reserved															
Type	RO	RO	RO	RO	RO	RO	RO	RO	RO	RO	RO	RO	RO	RO	RO	RO
Reset	0	0	0	0	0	0	0	0	0	0	0	0	0	0	0	0
	15	14	13	12	11	10	9	8	7	6	5	4	3	2	1	0
	reserved												SR			
Type	RO	RO	RO	RO	RO	RO	RO	RO	RO	RO	RO	RO	R/W	R/W	R/W	R/W
Reset	0	0	0	0	0	0	0	0	0	0	0	0	0	1	1	1

Bit/Field	Name	Type	Reset	Description																				
31:4	reserved	RO	0x0000.0000	Software should not rely on the value of a reserved bit. To provide compatibility with future products, the value of a reserved bit should be preserved across a read-modify-write operation.																				
3:0	SR	R/W	0x7	<p>ADC Sample Rate</p> <p>This field specifies the number of ADC conversions per second and is used in Run, Sleep, and Deep-sleep modes. The field encoding is based on the legacy RCGCG0 register encoding. The programmed sample rate cannot exceed the maximum sample rate specified by the MSR field in the ADCPP register. The SR field is encoded as follows:</p> <table border="1"> <thead> <tr> <th>Value</th> <th>Description</th> </tr> </thead> <tbody> <tr> <td>0x0</td> <td>Reserved</td> </tr> <tr> <td>0x1</td> <td>125 ksps</td> </tr> <tr> <td>0x2</td> <td>Reserved</td> </tr> <tr> <td>0x3</td> <td>250 ksps</td> </tr> <tr> <td>0x4</td> <td>Reserved</td> </tr> <tr> <td>0x5</td> <td>500 ksps</td> </tr> <tr> <td>0x6</td> <td>Reserved</td> </tr> <tr> <td>0x7</td> <td>1 Msps</td> </tr> <tr> <td>0x8 - 0xF</td> <td>Reserved</td> </tr> </tbody> </table>	Value	Description	0x0	Reserved	0x1	125 ksps	0x2	Reserved	0x3	250 ksps	0x4	Reserved	0x5	500 ksps	0x6	Reserved	0x7	1 Msps	0x8 - 0xF	Reserved
Value	Description																							
0x0	Reserved																							
0x1	125 ksps																							
0x2	Reserved																							
0x3	250 ksps																							
0x4	Reserved																							
0x5	500 ksps																							
0x6	Reserved																							
0x7	1 Msps																							
0x8 - 0xF	Reserved																							

Register 57: ADC Clock Configuration (ADCCC), offset 0xFC8

The ADCCC register controls the clock source for the ADC module.

ADC Clock Configuration (ADCCC)

ADC0 base: 0x4003.8000
 ADC1 base: 0x4003.9000
 Offset 0xFC8
 Type R/W, reset 0x0000.0000

	31	30	29	28	27	26	25	24	23	22	21	20	19	18	17	16
	reserved															
Type	RO	RO	RO	RO	RO	RO	RO	RO	RO	RO	RO	RO	RO	RO	RO	RO
Reset	0	0	0	0	0	0	0	0	0	0	0	0	0	0	0	0
	15	14	13	12	11	10	9	8	7	6	5	4	3	2	1	0
	reserved												CS			
Type	RO	RO	RO	RO	RO	RO	RO	RO	RO	RO	RO	RO	R/W	R/W	R/W	R/W
Reset	0	0	0	0	0	0	0	0	0	0	0	0	0	0	0	0

Bit/Field	Name	Type	Reset	Description
31:4	reserved	RO	0x0000.000	Software should not rely on the value of a reserved bit. To provide compatibility with future products, the value of a reserved bit should be preserved across a read-modify-write operation.

3:0	CS	R/W	0	ADC Clock Source The following table specifies the clock source that generates the ADC clock input, see Figure 5-5 on page 222.
-----	----	-----	---	--

Value	Description
0x0	Either the 16-MHz system clock (if the PLL bypass is in effect) or the 16 MHz clock derived from PLL + 25 (default). Note that when the PLL is bypassed, the system clock must be at least 16 MHz.
0x1	PIOSC The PIOSC provides a 16-MHz clock source for the ADC. If the PIOSC is used as the clock source, the ADC module can continue to operate in Deep-Sleep mode.
0x2 - 0xF	Reserved

13 Universal Asynchronous Receivers/Transmitters (UARTs)

The Stellaris® LM4F231H5QR controller includes eight Universal Asynchronous Receiver/Transmitter (UART) with the following features:

- Programmable baud-rate generator allowing speeds up to 5 Mbps for regular speed (divide by 16) and 10 Mbps for high speed (divide by 8)
- Separate 16x8 transmit (TX) and receive (RX) FIFOs to reduce CPU interrupt service loading
- Programmable FIFO length, including 1-byte deep operation providing conventional double-buffered interface
- FIFO trigger levels of 1/8, 1/4, 1/2, 3/4, and 7/8
- Standard asynchronous communication bits for start, stop, and parity
- Line-break generation and detection
- Fully programmable serial interface characteristics
 - 5, 6, 7, or 8 data bits
 - Even, odd, stick, or no-parity bit generation/detection
 - 1 or 2 stop bit generation
- IrDA serial-IR (SIR) encoder/decoder providing
 - Programmable use of IrDA Serial Infrared (SIR) or UART input/output
 - Support of IrDA SIR encoder/decoder functions for data rates up to 115.2 Kbps half-duplex
 - Support of normal 3/16 and low-power (1.41-2.23 μ s) bit durations
 - Programmable internal clock generator enabling division of reference clock by 1 to 256 for low-power mode bit duration
- Support for communication with ISO 7816 smart cards
- Modem flow control (on UART1)
- LIN protocol support
- EIA-485 9-bit support
- Standard FIFO-level and End-of-Transmission interrupts
- Efficient transfers using Micro Direct Memory Access Controller (μ DMA)
 - Separate channels for transmit and receive

- Receive single request asserted when data is in the FIFO; burst request asserted at programmed FIFO level
- Transmit single request asserted when there is space in the FIFO; burst request asserted at programmed FIFO level

13.1 Block Diagram

Figure 13-1. UART Module Block Diagram

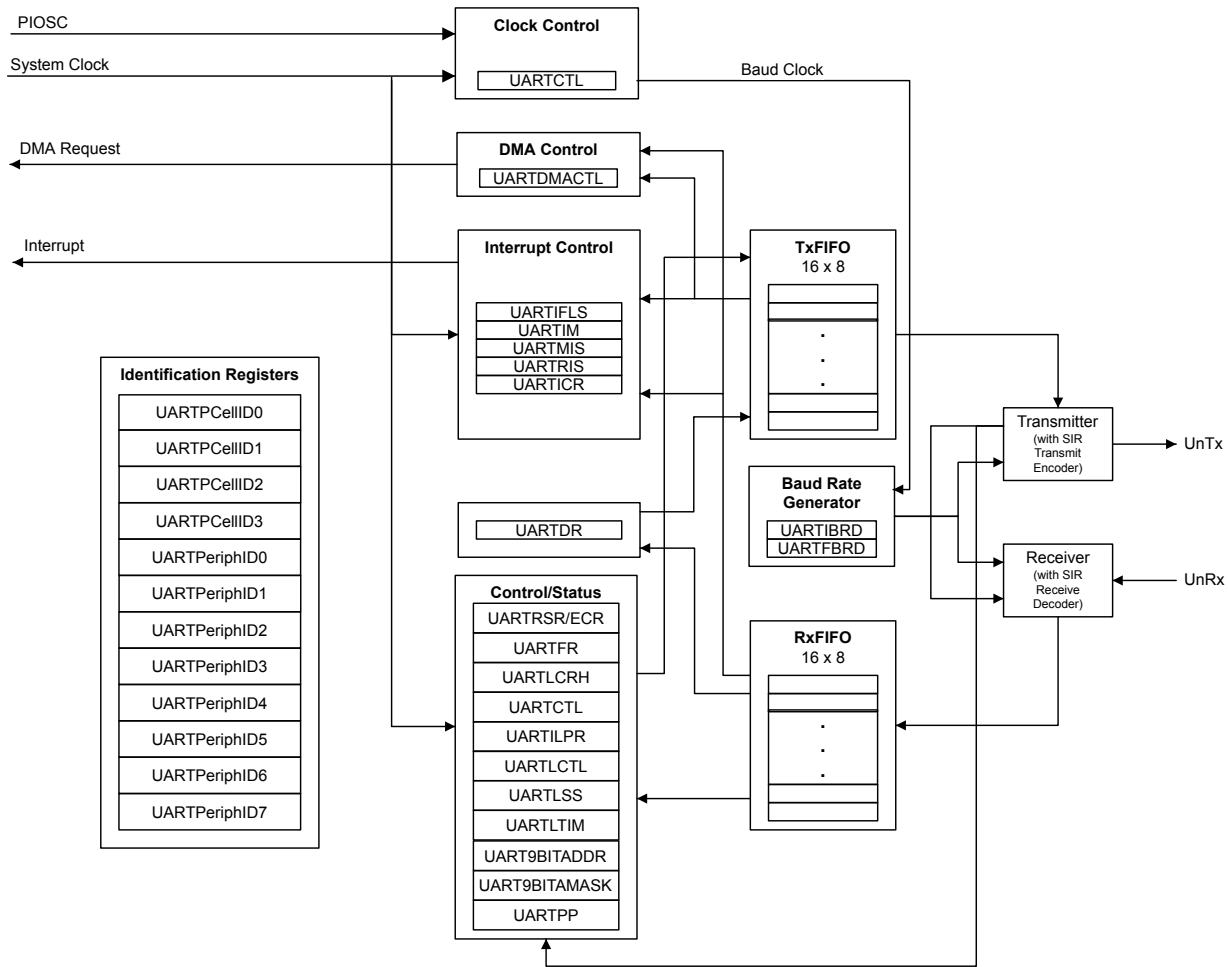

13.2 Signal Description

The following table lists the external signals of the UART module and describes the function of each. The UART signals are alternate functions for some GPIO signals and default to be GPIO signals at reset, with the exception of the *U0Rx* and *U0Tx* pins which default to the UART function. The column in the table below titled "Pin Mux/Pin Assignment" lists the possible GPIO pin placements for these UART signals. The *AFSEL* bit in the **GPIO Alternate Function Select (GPIOAFSEL)** register (page 644) should be set to choose the UART function. The number in parentheses is the encoding that must be programmed into the *PMCn* field in the **GPIO Port Control (GPIOCTL)** register (page 661) to assign the UART signal to the specified GPIO port pin. For more information on configuring GPIOs, see "General-Purpose Input/Outputs (GPIOs)" on page 623.

Table 13-1. UART Signals (64LQFP)

Pin Name	Pin Number	Pin Mux / Pin Assignment	Pin Type	Buffer Type ^a	Description
U0Rx	17	PA0 (1)	I	TTL	UART module 0 receive.
U0Tx	18	PA1 (1)	O	TTL	UART module 0 transmit.
U1CTS	15 29	PC5 (8) PF1 (1)	I	TTL	UART module 1 Clear To Send modem flow control input signal.
U1RTS	16 28	PC4 (8) PF0 (1)	O	TTL	UART module 1 Request to Send modem flow control output line.
U1Rx	16 45	PC4 (2) PB0 (1)	I	TTL	UART module 1 receive.
U1Tx	15 46	PC5 (2) PB1 (1)	O	TTL	UART module 1 transmit.
U2Rx	33 53	PG4 (1) PD6 (1)	I	TTL	UART module 2 receive.
U2Tx	10 32	PD7 (1) PG5 (1)	O	TTL	UART module 2 transmit.
U3Rx	14	PC6 (1)	I	TTL	UART module 3 receive.
U3Tx	13	PC7 (1)	O	TTL	UART module 3 transmit.
U4Rx	16	PC4 (1)	I	TTL	UART module 4 receive.
U4Tx	15	PC5 (1)	O	TTL	UART module 4 transmit.
U5Rx	59	PE4 (1)	I	TTL	UART module 5 receive.
U5Tx	60	PE5 (1)	O	TTL	UART module 5 transmit.
U6Rx	43	PD4 (1)	I	TTL	UART module 6 receive.
U6Tx	44	PD5 (1)	O	TTL	UART module 6 transmit.
U7Rx	9	PE0 (1)	I	TTL	UART module 7 receive.
U7Tx	8	PE1 (1)	O	TTL	UART module 7 transmit.

a. The TTL designation indicates the pin has TTL-compatible voltage levels.

13.3 Functional Description

Each Stellaris UART performs the functions of parallel-to-serial and serial-to-parallel conversions. It is similar in functionality to a 16C550 UART, but is not register compatible.

The UART is configured for transmit and/or receive via the `TXE` and `RXE` bits of the **UART Control (UARTCTL)** register (see page 881). Transmit and receive are both enabled out of reset. Before any control registers are programmed, the UART must be disabled by clearing the `UARTEN` bit in **UARTCTL**. If the UART is disabled during a TX or RX operation, the current transaction is completed prior to the UART stopping.

The UART module also includes a serial IR (SIR) encoder/decoder block that can be connected to an infrared transceiver to implement an IrDA SIR physical layer. The SIR function is programmed using the **UARTCTL** register.

13.3.1 Transmit/Receive Logic

The transmit logic performs parallel-to-serial conversion on the data read from the transmit FIFO. The control logic outputs the serial bit stream beginning with a start bit and followed by the data bits (LSB first), parity bit, and the stop bits according to the programmed configuration in the control registers. See Figure 13-2 on page 858 for details.

The receive logic performs serial-to-parallel conversion on the received bit stream after a valid start pulse has been detected. Overrun, parity, frame error checking, and line-break detection are also performed, and their status accompanies the data that is written to the receive FIFO.

Figure 13-2. UART Character Frame

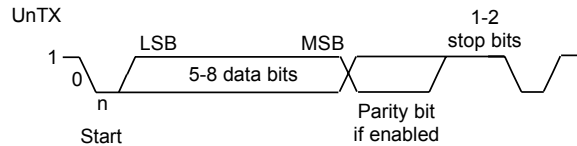

13.3.2 Baud-Rate Generation

The baud-rate divisor is a 22-bit number consisting of a 16-bit integer and a 6-bit fractional part. The number formed by these two values is used by the baud-rate generator to determine the bit period. Having a fractional baud-rate divisor allows the UART to generate all the standard baud rates.

The 16-bit integer is loaded through the **UART Integer Baud-Rate Divisor (UARTIBRD)** register (see page 877) and the 6-bit fractional part is loaded with the **UART Fractional Baud-Rate Divisor (UARTFBRD)** register (see page 878). The baud-rate divisor (BRD) has the following relationship to the system clock (where *BRDI* is the integer part of the BRD and *BRDF* is the fractional part, separated by a decimal place.)

$$BRD = BRDI + BRDF = \text{UARTSysClk} / (\text{ClkDiv} * \text{Baud Rate})$$

where *UARTSysClk* is the system clock connected to the UART, and *ClkDiv* is either 16 (if *HSE* in **UARTCTL** is clear) or 8 (if *HSE* is set). By default, this will be the main system clock described in “Clock Control” on page 220. Alternatively, the UART may be clocked from the internal precision oscillator (PIOSC), independent of the system clock selection. This will allow the UART clock to be programmed independently of the system clock PLL settings. See the **UARTCC** register for more details.

The 6-bit fractional number (that is to be loaded into the *DIVFRAC* bit field in the **UARTFBRD** register) can be calculated by taking the fractional part of the baud-rate divisor, multiplying it by 64, and adding 0.5 to account for rounding errors:

$$\text{UARTFBRD}[\text{DIVFRAC}] = \text{integer}(\text{BRDF} * 64 + 0.5)$$

The UART generates an internal baud-rate reference clock at 8x or 16x the baud-rate (referred to as *Baud8* and *Baud16*, depending on the setting of the *HSE* bit (bit 5) in **UARTCTL**). This reference clock is divided by 8 or 16 to generate the transmit clock, and is used for error detection during receive operations. Note that the state of the *HSE* bit has no effect on clock generation in ISO 7816 smart card mode (when the *SMART* bit in the **UARTCTL** register is set).

Along with the **UART Line Control, High Byte (UARTLCRH)** register (see page 879), the **UARTIBRD** and **UARTFBRD** registers form an internal 30-bit register. This internal register is only updated when a write operation to **UARTLCRH** is performed, so any changes to the baud-rate divisor must be followed by a write to the **UARTLCRH** register for the changes to take effect.

To update the baud-rate registers, there are four possible sequences:

- **UARTIBRD** write, **UARTFBRD** write, and **UARTLCRH** write
- **UARTFBRD** write, **UARTIBRD** write, and **UARTLCRH** write
- **UARTIBRD** write and **UARTLCRH** write

- **UARTFBRD** write and **UARTLCRH** write

13.3.3 Data Transmission

Data received or transmitted is stored in two 16-byte FIFOs, though the receive FIFO has an extra four bits per character for status information. For transmission, data is written into the transmit FIFO. If the UART is enabled, it causes a data frame to start transmitting with the parameters indicated in the **UARTLCRH** register. Data continues to be transmitted until there is no data left in the transmit FIFO. The **BUSY** bit in the **UART Flag (UARTFR)** register (see page 874) is asserted as soon as data is written to the transmit FIFO (that is, if the FIFO is non-empty) and remains asserted while data is being transmitted. The **BUSY** bit is negated only when the transmit FIFO is empty, and the last character has been transmitted from the shift register, including the stop bits. The UART can indicate that it is busy even though the UART may no longer be enabled.

When the receiver is idle (the $UnRx$ signal is continuously 1), and the data input goes Low (a start bit has been received), the receive counter begins running and data is sampled on the eighth cycle of $Baud16$ or fourth cycle of $Baud8$ depending on the setting of the **HSE** bit (bit 5) in **UARTCTL** (described in “Transmit/Receive Logic” on page 857).

The start bit is valid and recognized if the $UnRx$ signal is still low on the eighth cycle of $Baud16$ (**HSE** clear) or the fourth cycle of $Baud8$ (**HSE** set), otherwise it is ignored. After a valid start bit is detected, successive data bits are sampled on every 16th cycle of $Baud16$ or 8th cycle of $Baud8$ (that is, one bit period later) according to the programmed length of the data characters and value of the **HSE** bit in **UARTCTL**. The parity bit is then checked if parity mode is enabled. Data length and parity are defined in the **UARTLCRH** register.

Lastly, a valid stop bit is confirmed if the $UnRx$ signal is High, otherwise a framing error has occurred. When a full word is received, the data is stored in the receive FIFO along with any error bits associated with that word.

13.3.4 Serial IR (SIR)

The UART peripheral includes an IrDA serial-IR (SIR) encoder/decoder block. The IrDA SIR block provides functionality that converts between an asynchronous UART data stream and a half-duplex serial SIR interface. No analog processing is performed on-chip. The role of the SIR block is to provide a digital encoded output and decoded input to the UART. When enabled, the SIR block uses the $UnTx$ and $UnRx$ pins for the SIR protocol. These signals should be connected to an infrared transceiver to implement an IrDA SIR physical layer link. The SIR block can receive and transmit, but it is only half-duplex so it cannot do both at the same time. Transmission must be stopped before data can be received. The IrDA SIR physical layer specifies a minimum 10-ms delay between transmission and reception. The SIR block has two modes of operation:

- In normal IrDA mode, a zero logic level is transmitted as a high pulse of 3/16th duration of the selected baud rate bit period on the output pin, while logic one levels are transmitted as a static LOW signal. These levels control the driver of an infrared transmitter, sending a pulse of light for each zero. On the reception side, the incoming light pulses energize the photo transistor base of the receiver, pulling its output LOW and driving the UART input pin LOW.
- In low-power IrDA mode, the width of the transmitted infrared pulse is set to three times the period of the internally generated $IrLPBaud16$ signal (1.63 μ s, assuming a nominal 1.8432 MHz frequency) by changing the appropriate bit in the **UARTCR** register. See page 876 for more information on IrDA low-power pulse-duration configuration.

Figure 13-3 on page 860 shows the UART transmit and receive signals, with and without IrDA modulation.

Figure 13-3. IrDA Data Modulation

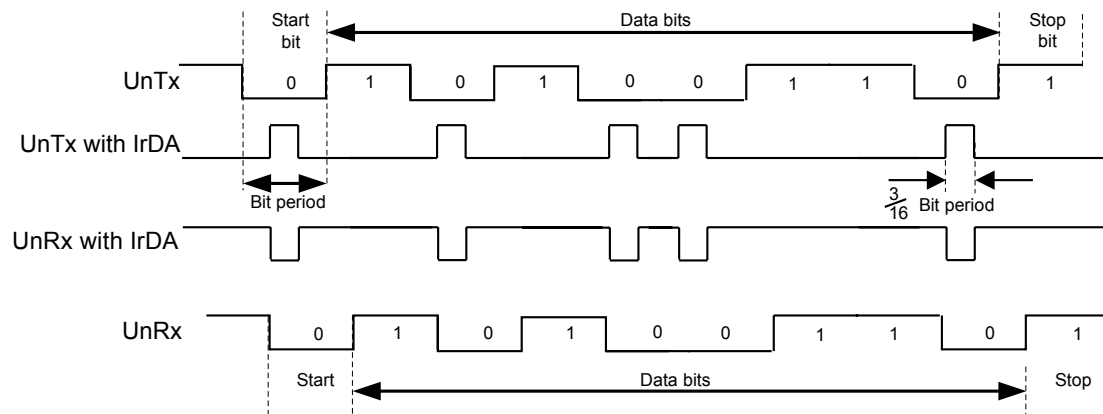

In both normal and low-power IrDA modes:

- During transmission, the UART data bit is used as the base for encoding
- During reception, the decoded bits are transferred to the UART receive logic

The IrDA SIR physical layer specifies a half-duplex communication link, with a minimum 10-ms delay between transmission and reception. This delay must be generated by software because it is not automatically supported by the UART. The delay is required because the infrared receiver electronics might become biased or even saturated from the optical power coupled from the adjacent transmitter LED. This delay is known as latency or receiver setup time.

13.3.5 ISO 7816 Support

The UART offers basic support to allow communication with an ISO 7816 smartcard. When bit 3 (**SMART**) of the **UARTCTL** register is set, the **UnTx** signal is used as a bit clock, and the **UnRx** signal is used as the half-duplex communication line connected to the smartcard. A GPIO signal can be used to generate the reset signal to the smartcard. The remaining smartcard signals should be provided by the system design. The maximum clock rate in this mode is system clock / 16.

When using ISO 7816 mode, the **UARTLCRH** register must be set to transmit 8-bit words (**WLEN** bits 6:5 configured to 0x3) with EVEN parity (**PEN** set and **EPS** set). In this mode, the UART automatically uses 2 stop bits, and the **STP2** bit of the **UARTLCRH** register is ignored.

If a parity error is detected during transmission, **UnRx** is pulled Low during the second stop bit. In this case, the UART aborts the transmission, flushes the transmit FIFO and discards any data it contains, and raises a parity error interrupt, allowing software to detect the problem and initiate retransmission of the affected data. Note that the UART does not support automatic retransmission in this case.

13.3.6 Modem Handshake Support

This section describes how to configure and use the modem flow control signals for UART1 when connected as a DTE (data terminal equipment) or as a DCE (data communications equipment). In general, a modem is a DCE and a computing device that connects to a modem is the DTE.

13.3.6.1 Signaling

The status signals provided by UART1 differ based on whether the UART is used as a DTE or DCE. When used as a DTE, the modem flow control signals are defined as:

- $\overline{\text{UICTS}}$ is Clear To Send
- $\overline{\text{UIRTS}}$ is Request To Send

When used as a DCE, the the modem flow control signals are defined as:

- $\overline{\text{UICTS}}$ is Request To Send
- $\overline{\text{UIRTS}}$ is Clear To Send

13.3.6.2 Flow Control

Flow control can be accomplished by either hardware or software. The following sections describe the different methods.

Hardware Flow Control (RTS/CTS)

Hardware flow control between two devices is accomplished by connecting the $\overline{\text{UIRTS}}$ output to the Clear-To-Send input on the receiving device, and connecting the Request-To-Send output on the receiving device to the $\overline{\text{UICTS}}$ input.

The $\overline{\text{UICTS}}$ input controls the transmitter. The transmitter may only transmit data when the $\overline{\text{UICTS}}$ input is asserted. The $\overline{\text{UIRTS}}$ output signal indicates the state of the receive FIFO. $\overline{\text{UICTS}}$ remains asserted until the preprogrammed watermark level is reached, indicating that the Receive FIFO has no space to store additional characters.

The **UARTCTL** register bits 15 (CTSEN) and 14 (RTSEN) specify the flow control mode as shown in Table 13-2 on page 861.

Table 13-2. Flow Control Mode

CTSEN	RTSEN	Description
1	1	RTS and CTS flow control enabled
1	0	Only CTS flow control enabled
0	1	Only RTS flow control enabled
0	0	Both RTS and CTS flow control disabled

Note that when RTSEN is 1, software cannot modify the $\overline{\text{UIRTS}}$ output value through the **UARTCTL** register Request to Send (RTS) bit, and the status of the RTS bit should be ignored.

Software Flow Control (Modem Status Interrupts)

Software flow control between two devices is accomplished by using interrupts to indicate the status of the UART. Interrupts may be generated for the $\overline{\text{UICTS}}$ signal using bit 3 of the **UARTIM** register. The raw and masked interrupt status may be checked using the **UARTRIS** and **UARTMIS** register. These interrupts may be cleared using the **UARTICR** register.

13.3.7 LIN Support

The UART module offers hardware support for the LIN protocol as either a master or a slave. The LIN mode is enabled by setting the LIN bit in the **UARTCTL** register. A LIN message is identified by the use of a Sync Break at the beginning of the message. The Sync Break is a transmission of a series of 0s. The Sync Break is followed by the Sync data field (0x55). Figure 13-4 on page 862 illustrates the structure of a LIN message.

Figure 13-4. LIN Message

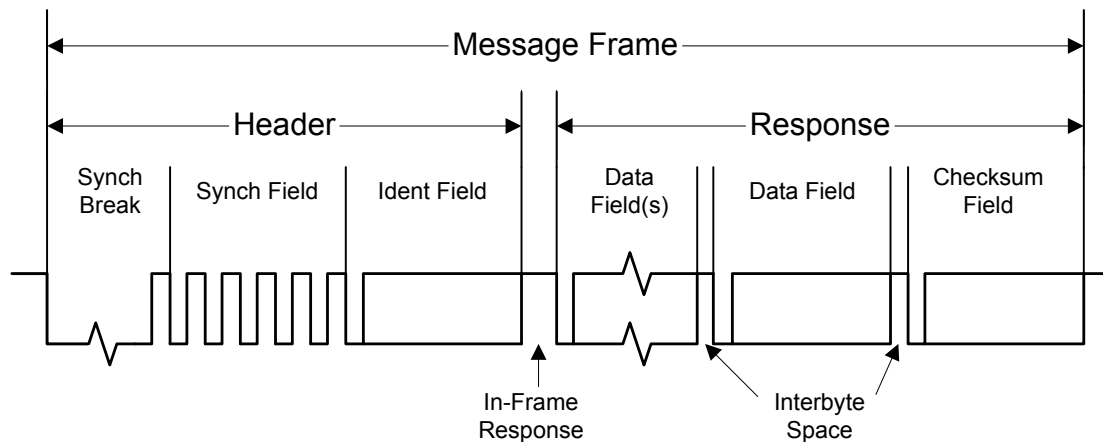

The UART should be configured as followed to operate in LIN mode:

1. Configure the UART for 1 start bit, 8 data bits, no parity, and 1 stop bit. Enable the Transmit FIFO.
2. Set the `LIN` bit in the `UARTCTL` register.

When preparing to send a LIN message, the TXFIFO should contain the Sync data (0x55) at FIFO location 0 and the Identifier data at location 1, followed by the data to be transmitted, and with the checksum in the final FIFO entry.

13.3.7.1 LIN Master

The UART is enabled to be the LIN master by setting the `MASTER` bit in the `UARTLCTL` register. The length of the Sync Break is programmable using the `BLEN` field in the `UARTLCTL` register and can be 13-16 bits (baud clock cycles).

13.3.7.2 LIN Slave

The LIN UART slave is required to adjust its baud rate to that of the LIN master. In slave mode, the LIN UART recognizes the Sync Break, which must be at least 13 bits in duration. A timer is provided to capture timing data on the 1st and 5th falling edges of the Sync field so that the baud rate can be adjusted to match the master.

After detecting a Sync Break, the UART waits for the synchronization field. The first falling edge generates an interrupt using the `LME1RIS` bit in the `UARTRIS` register, and the timer value is captured and stored in the `UARTLSS` register (T1). On the fifth falling edge, a second interrupt is generated using the `LME5RIS` bit in the `UARTRIS` register, and the timer value is captured again (T2). The actual baud rate can be calculated using $(T2-T1)/8$, and the local baud rate should be adjusted as needed. Figure 13-5 on page 863 illustrates the synchronization field.

Figure 13-5. LIN Synchronization Field

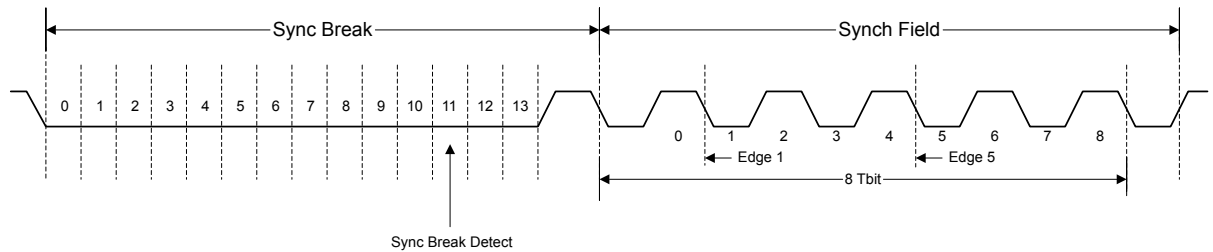

13.3.8 9-Bit UART Mode

The UART provides a 9-bit mode that is enabled with the `9BITEN` bit in the `UART9BITADDR` register. This feature is useful in a multi-drop configuration of the UART where a single master connected to multiple slaves can communicate with a particular slave through its address or set of addresses along with a qualifier for an address byte. All the slaves check for the address qualifier in the place of the parity bit and, if set, then compare the byte received with the preprogrammed address. If the address matches, then it receives or sends further data. If the address does not match, it drops the address byte and any subsequent data bytes. If the UART is in 9-bit mode, then the receiver operates with no parity mode. The address can be predefined to match with the received byte and it can be configured with the `UART9BITADDR` register. The matching can be extended to a set of addresses using the address mask in the `UART9BITAMASK` register. By default, the `UART9BITAMASK` is `0xFF`, meaning that only the specified address is matched.

When not finding a match, the rest of the data bytes with the 9th bit cleared are dropped. If a match is found, then an interrupt is generated to the NVIC for further action. The subsequent data bytes with the cleared 9th bit are stored in the FIFO. Software can mask this interrupt in case μ DMA and/or FIFO operations are enabled for this instance and processor intervention is not required. All the send transactions with 9-bit mode are data bytes and the 9th bit is cleared. Software can override the 9th bit to be set (to indicate address) by overriding the parity settings to sticky parity with odd parity enabled for a particular byte. To match the transmission time with correct parity settings, the address byte can be transmitted as a single then a burst transfer. The Transmit FIFO does not hold the address/data bit, hence software should take care of enabling the address bit appropriately.

13.3.9 FIFO Operation

The UART has two 16x8 FIFOs; one for transmit and one for receive. Both FIFOs are accessed via the `UART Data (UARTDR)` register (see page 869). Read operations of the `UARTDR` register return a 12-bit value consisting of 8 data bits and 4 error flags while write operations place 8-bit data in the transmit FIFO.

Out of reset, both FIFOs are disabled and act as 1-byte-deep holding registers. The FIFOs are enabled by setting the `FEN` bit in `UARTLCRH` (page 879).

FIFO status can be monitored via the `UART Flag (UARTFR)` register (see page 874) and the `UART Receive Status (UARTSR)` register. Hardware monitors empty, full and overrun conditions. The `UARTFR` register contains empty and full flags (`TXFE`, `TXFF`, `RXFE`, and `RXFF` bits), and the `UARTSR` register shows overrun status via the `OE` bit. If the FIFOs are disabled, the empty and full flags are set according to the status of the 1-byte-deep holding registers.

The trigger points at which the FIFOs generate interrupts is controlled via the `UART Interrupt FIFO Level Select (UARTIFLS)` register (see page 885). Both FIFOs can be individually configured to trigger interrupts at different levels. Available configurations include $\frac{1}{8}$, $\frac{1}{4}$, $\frac{1}{2}$, $\frac{3}{4}$, and $\frac{7}{8}$. For example,

if the $\frac{1}{4}$ option is selected for the receive FIFO, the UART generates a receive interrupt after 4 data bytes are received. Out of reset, both FIFOs are configured to trigger an interrupt at the $\frac{1}{2}$ mark.

13.3.10 Interrupts

The UART can generate interrupts when the following conditions are observed:

- Overrun Error
- Break Error
- Parity Error
- Framing Error
- Receive Timeout
- Transmit (when condition defined in the `TXIFLSEL` bit in the **UARTIFLS** register is met, or if the `EOT` bit in **UARTCTL** is set, when the last bit of all transmitted data leaves the serializer)
- Receive (when condition defined in the `RXIFLSEL` bit in the **UARTIFLS** register is met)

All of the interrupt events are ORed together before being sent to the interrupt controller, so the UART can only generate a single interrupt request to the controller at any given time. Software can service multiple interrupt events in a single interrupt service routine by reading the **UART Masked Interrupt Status (UARTMIS)** register (see page 893).

The interrupt events that can trigger a controller-level interrupt are defined in the **UART Interrupt Mask (UARTIM)** register (see page 887) by setting the corresponding `IM` bits. If interrupts are not used, the raw interrupt status is always visible via the **UART Raw Interrupt Status (UARTRIS)** register (see page 890).

Interrupts are always cleared (for both the **UARTMIS** and **UARTRIS** registers) by writing a 1 to the corresponding bit in the **UART Interrupt Clear (UARTICR)** register (see page 896).

The receive timeout interrupt is asserted when the receive FIFO is not empty, and no further data is received over a 32-bit period. The receive timeout interrupt is cleared either when the FIFO becomes empty through reading all the data (or by reading the holding register), or when a 1 is written to the corresponding bit in the **UARTICR** register.

The receive interrupt changes state when one of the following events occurs:

- If the FIFOs are enabled and the receive FIFO reaches the programmed trigger level, the `RXRIS` bit is set. The receive interrupt is cleared by reading data from the receive FIFO until it becomes less than the trigger level, or by clearing the interrupt by writing a 1 to the `RXIC` bit.
- If the FIFOs are disabled (have a depth of one location) and data is received thereby filling the location, the `RXRIS` bit is set. The receive interrupt is cleared by performing a single read of the receive FIFO, or by clearing the interrupt by writing a 1 to the `RXIC` bit.

The transmit interrupt changes state when one of the following events occurs:

- If the FIFOs are enabled and the transmit FIFO reaches the programmed trigger level, the `TXRIS` bit is set. The transmit interrupt is cleared by writing data to the transmit FIFO until it becomes greater than the trigger level, or by clearing the interrupt by writing a 1 to the `TXIC` bit.

- If the FIFOs are disabled (have a depth of one location) and there is no data present in the transmitters single location, the `TXRIS` bit is set. It is cleared by performing a single write to the transmit FIFO, or by clearing the interrupt by writing a 1 to the `TXIC` bit.

13.3.11 Loopback Operation

The UART can be placed into an internal loopback mode for diagnostic or debug work by setting the `LBE` bit in the `UARTCTL` register (see page 881). In loopback mode, data transmitted on the `UnTx` output is received on the `UnRx` input. Note that the `LBE` bit should be set before the UART is enabled.

13.3.12 DMA Operation

The UART provides an interface to the μ DMA controller with separate channels for transmit and receive. The DMA operation of the UART is enabled through the **UART DMA Control (UARTDMACTL)** register. When DMA operation is enabled, the UART asserts a DMA request on the receive or transmit channel when the associated FIFO can transfer data. For the receive channel, a single transfer request is asserted whenever any data is in the receive FIFO. A burst transfer request is asserted whenever the amount of data in the receive FIFO is at or above the FIFO trigger level configured in the `UARTIFLS` register. For the transmit channel, a single transfer request is asserted whenever there is at least one empty location in the transmit FIFO. The burst request is asserted whenever the transmit FIFO contains fewer characters than the FIFO trigger level. The single and burst DMA transfer requests are handled automatically by the μ DMA controller depending on how the DMA channel is configured.

To enable DMA operation for the receive channel, set the `RXDMAE` bit of the **DMA Control (UARTDMACTL)** register. To enable DMA operation for the transmit channel, set the `TXDMAE` bit of the `UARTDMACTL` register. The UART can also be configured to stop using DMA for the receive channel if a receive error occurs. If the `DMAERR` bit of the `UARTDMACR` register is set and a receive error occurs, the DMA receive requests are automatically disabled. This error condition can be cleared by clearing the appropriate UART error interrupt.

If DMA is enabled, then the μ DMA controller triggers an interrupt when a transfer is complete. The interrupt occurs on the UART interrupt vector. Therefore, if interrupts are used for UART operation and DMA is enabled, the UART interrupt handler must be designed to handle the μ DMA completion interrupt.

See “Micro Direct Memory Access (μ DMA)” on page 559 for more details about programming the μ DMA controller.

13.4 Initialization and Configuration

To enable and initialize the UART, the following steps are necessary:

1. Enable the UART module using the `RCGCUART` register (see page 322).
2. Enable the clock to the appropriate GPIO module via the `RCGCGPIO` register (see page 319). To find out which GPIO port to enable, refer to Table 22-5 on page 1314.
3. Set the GPIO `AFSEL` bits for the appropriate pins (see page 644). To determine which GPIOs to configure, see Table 22-4 on page 1307.
4. Configure the GPIO current level and/or slew rate as specified for the mode selected (see page 646 and page 654).

5. Configure the `PMCn` fields in the **GPIOPCTL** register to assign the UART signals to the appropriate pins (see page 661 and Table 22-5 on page 1314).

To use the UART, the peripheral clock must be enabled by setting the appropriate bit in the **RCGCUART** register (page 322). In addition, the clock to the appropriate GPIO module must be enabled via the **RCGCGPIO** register (page 319) in the System Control module. To find out which GPIO port to enable, refer to Table 22-5 on page 1314.

This section discusses the steps that are required to use a UART module. For this example, the UART clock is assumed to be 20 MHz, and the desired UART configuration is:

- 115200 baud rate
- Data length of 8 bits
- One stop bit
- No parity
- FIFOs disabled
- No interrupts

The first thing to consider when programming the UART is the baud-rate divisor (BRD), because the **UARTIBRD** and **UARTFBRD** registers must be written before the **UARTLCRH** register. Using the equation described in “Baud-Rate Generation” on page 858, the BRD can be calculated:

$$\text{BRD} = 20,000,000 / (16 * 115,200) = 10.8507$$

which means that the `DIVINT` field of the **UARTIBRD** register (see page 877) should be set to 10 decimal or 0xA. The value to be loaded into the **UARTFBRD** register (see page 878) is calculated by the equation:

$$\text{UARTFBRD}[\text{DIVFRAC}] = \text{integer}(0.8507 * 64 + 0.5) = 54$$

With the BRD values in hand, the UART configuration is written to the module in the following order:

1. Disable the UART by clearing the `UARTEN` bit in the **UARTCTL** register.
2. Write the integer portion of the BRD to the **UARTIBRD** register.
3. Write the fractional portion of the BRD to the **UARTFBRD** register.
4. Write the desired serial parameters to the **UARTLCRH** register (in this case, a value of 0x0000.0060).
5. Configure the UART clock source by writing to the **UARTCC** register.
6. Optionally, configure the μ DMA channel (see “Micro Direct Memory Access (μ DMA)” on page 559) and enable the DMA option(s) in the **UARTDMACTL** register.
7. Enable the UART by setting the `UARTEN` bit in the **UARTCTL** register.

13.5 Register Map

Table 13-3 on page 867 lists the UART registers. The offset listed is a hexadecimal increment to the register’s address, relative to that UART’s base address:

- UART0: 0x4000.C000
- UART1: 0x4000.D000
- UART2: 0x4000.E000
- UART3: 0x4000.F000
- UART4: 0x4001.0000
- UART5: 0x4001.1000
- UART6: 0x4001.2000
- UART7: 0x4001.3000

Note that the UART module clock must be enabled before the registers can be programmed (see page 322). There must be a delay of 3 system clocks after the UART module clock is enabled before any UART module registers are accessed.

Note: The UART must be disabled (see the `UARTEN` bit in the `UARTCTL` register on page 881) before any of the control registers are reprogrammed. When the UART is disabled during a TX or RX operation, the current transaction is completed prior to the UART stopping.

Table 13-3. UART Register Map

Offset	Name	Type	Reset	Description	See page
0x000	UARTDR	R/W	0x0000.0000	UART Data	869
0x004	UARTSR/UARTECR	R/W	0x0000.0000	UART Receive Status/Error Clear	871
0x018	UARTFR	RO	0x0000.0090	UART Flag	874
0x020	UARTILPR	R/W	0x0000.0000	UART IrDA Low-Power Register	876
0x024	UARTIBRD	R/W	0x0000.0000	UART Integer Baud-Rate Divisor	877
0x028	UARTFBRD	R/W	0x0000.0000	UART Fractional Baud-Rate Divisor	878
0x02C	UARTLCRH	R/W	0x0000.0000	UART Line Control	879
0x030	UARTCTL	R/W	0x0000.0300	UART Control	881
0x034	UARTIFLS	R/W	0x0000.0012	UART Interrupt FIFO Level Select	885
0x038	UARTIM	R/W	0x0000.0000	UART Interrupt Mask	887
0x03C	UARTRIS	RO	0x0000.000F	UART Raw Interrupt Status	890
0x040	UARTMIS	RO	0x0000.0000	UART Masked Interrupt Status	893
0x044	UARTICR	W1C	0x0000.0000	UART Interrupt Clear	896
0x048	UARTDMACTL	R/W	0x0000.0000	UART DMA Control	898
0x090	UARTLCTL	R/W	0x0000.0000	UART LIN Control	899
0x094	UARTLSS	RO	0x0000.0000	UART LIN Snap Shot	900
0x098	UARTLTIM	RO	0x0000.0000	UART LIN Timer	901
0x0A4	UART9BITADDR	R/W	0x0000.0000	UART 9-Bit Self Address	902
0x0A8	UART9BITAMASK	R/W	0x0000.00FF	UART 9-Bit Self Address Mask	903
0xFC0	UARTPP	RO	0x0000.0003	UART Peripheral Properties	904
0xFC8	UARTCC	R/W	0x0000.0000	UART Clock Configuration	905

Table 13-3. UART Register Map (continued)

Offset	Name	Type	Reset	Description	See page
0xFD0	UARTPeriphID4	RO	0x0000.0000	UART Peripheral Identification 4	906
0xFD4	UARTPeriphID5	RO	0x0000.0000	UART Peripheral Identification 5	907
0xFD8	UARTPeriphID6	RO	0x0000.0000	UART Peripheral Identification 6	908
0xFDC	UARTPeriphID7	RO	0x0000.0000	UART Peripheral Identification 7	909
0xFE0	UARTPeriphID0	RO	0x0000.0060	UART Peripheral Identification 0	910
0xFE4	UARTPeriphID1	RO	0x0000.0000	UART Peripheral Identification 1	911
0xFE8	UARTPeriphID2	RO	0x0000.0018	UART Peripheral Identification 2	912
0xFEC	UARTPeriphID3	RO	0x0000.0001	UART Peripheral Identification 3	913
0xFF0	UARTPCellID0	RO	0x0000.000D	UART PrimeCell Identification 0	914
0xFF4	UARTPCellID1	RO	0x0000.00F0	UART PrimeCell Identification 1	915
0xFF8	UARTPCellID2	RO	0x0000.0005	UART PrimeCell Identification 2	916
0xFFC	UARTPCellID3	RO	0x0000.00B1	UART PrimeCell Identification 3	917

13.6 Register Descriptions

The remainder of this section lists and describes the UART registers, in numerical order by address offset.

Register 1: UART Data (UARTDR), offset 0x000

Important: This register is read-sensitive. See the register description for details.

This register is the data register (the interface to the FIFOs).

For transmitted data, if the FIFO is enabled, data written to this location is pushed onto the transmit FIFO. If the FIFO is disabled, data is stored in the transmitter holding register (the bottom word of the transmit FIFO). A write to this register initiates a transmission from the UART.

For received data, if the FIFO is enabled, the data byte and the 4-bit status (break, frame, parity, and overrun) is pushed onto the 12-bit wide receive FIFO. If the FIFO is disabled, the data byte and status are stored in the receiving holding register (the bottom word of the receive FIFO). The received data can be retrieved by reading this register.

UART Data (UARTDR)

UART0 base: 0x4000.C000
 UART1 base: 0x4000.D000
 UART2 base: 0x4000.E000
 UART3 base: 0x4000.F000
 UART4 base: 0x4001.0000
 UART5 base: 0x4001.1000
 UART6 base: 0x4001.2000
 UART7 base: 0x4001.3000
 Offset 0x000
 Type R/W, reset 0x0000.0000

	31	30	29	28	27	26	25	24	23	22	21	20	19	18	17	16
	reserved															
Type	RO	RO	RO	RO	RO	RO	RO	RO	RO	RO	RO	RO	RO	RO	RO	RO
Reset	0	0	0	0	0	0	0	0	0	0	0	0	0	0	0	0
	15	14	13	12	11	10	9	8	7	6	5	4	3	2	1	0
	reserved				OE	BE	PE	FE	DATA							
Type	RO	RO	RO	RO	RO	RO	RO	RO	R/W	R/W	R/W	R/W	R/W	R/W	R/W	R/W
Reset	0	0	0	0	0	0	0	0	0	0	0	0	0	0	0	0

Bit/Field	Name	Type	Reset	Description
31:12	reserved	RO	0x0000.0	Software should not rely on the value of a reserved bit. To provide compatibility with future products, the value of a reserved bit should be preserved across a read-modify-write operation.
11	OE	RO	0	UART Overrun Error
				Value Description
				1 New data was received when the FIFO was full, resulting in data loss.
				0 No data has been lost due to a FIFO overrun.

Bit/Field	Name	Type	Reset	Description
10	BE	RO	0	<p>UART Break Error</p> <p>Value Description</p> <p>1 A break condition has been detected, indicating that the receive data input was held Low for longer than a full-word transmission time (defined as start, data, parity, and stop bits).</p> <p>0 No break condition has occurred</p> <p>In FIFO mode, this error is associated with the character at the top of the FIFO. When a break occurs, only one 0 character is loaded into the FIFO. The next character is only enabled after the received data input goes to a 1 (marking state), and the next valid start bit is received.</p>
9	PE	RO	0	<p>UART Parity Error</p> <p>Value Description</p> <p>1 The parity of the received data character does not match the parity defined by bits 2 and 7 of the UARTLCRH register.</p> <p>0 No parity error has occurred</p> <p>In FIFO mode, this error is associated with the character at the top of the FIFO.</p>
8	FE	RO	0	<p>UART Framing Error</p> <p>Value Description</p> <p>1 The received character does not have a valid stop bit (a valid stop bit is 1).</p> <p>0 No framing error has occurred</p>
7:0	DATA	R/W	0x00	<p>Data Transmitted or Received</p> <p>Data that is to be transmitted via the UART is written to this field. When read, this field contains the data that was received by the UART.</p>

Register 2: UART Receive Status/Error Clear (UARTRSR/UARTECR), offset 0x004

The **UARTRSR/UARTECR** register is the receive status register/error clear register.

In addition to the **UARTDR** register, receive status can also be read from the **UARTRSR** register. If the status is read from this register, then the status information corresponds to the entry read from **UARTDR** prior to reading **UARTRSR**. The status information for overrun is set immediately when an overrun condition occurs.

The **UARTRSR** register cannot be written.

A write of any value to the **UARTECR** register clears the framing, parity, break, and overrun errors. All the bits are cleared on reset.

Read-Only Status Register

UART Receive Status/Error Clear (UARTRSR/UARTECR)

UART0 base: 0x4000.C000
 UART1 base: 0x4000.D000
 UART2 base: 0x4000.E000
 UART3 base: 0x4000.F000
 UART4 base: 0x4001.0000
 UART5 base: 0x4001.1000
 UART6 base: 0x4001.2000
 UART7 base: 0x4001.3000
 Offset 0x004
 Type RO, reset 0x0000.0000

	31	30	29	28	27	26	25	24	23	22	21	20	19	18	17	16	
	reserved																
Type	RO	RO	RO	RO	RO	RO	RO	RO	RO	RO	RO	RO	RO	RO	RO	RO	
Reset	0	0	0	0	0	0	0	0	0	0	0	0	0	0	0	0	
	15	14	13	12	11	10	9	8	7	6	5	4	3	2	1	0	
	reserved													OE	BE	PE	FE
Type	RO	RO	RO	RO	RO	RO	RO	RO	RO	RO	RO	RO	RO	RO	RO	RO	
Reset	0	0	0	0	0	0	0	0	0	0	0	0	0	0	0	0	

Bit/Field	Name	Type	Reset	Description
31:4	reserved	RO	0x0000.000	Software should not rely on the value of a reserved bit. To provide compatibility with future products, the value of a reserved bit should be preserved across a read-modify-write operation.

3	OE	RO	0	UART Overrun Error
---	----	----	---	--------------------

Value Description

Value	Description
1	New data was received when the FIFO was full, resulting in data loss.
0	No data has been lost due to a FIFO overrun.

This bit is cleared by a write to **UARTECR**.

The FIFO contents remain valid because no further data is written when the FIFO is full, only the contents of the shift register are overwritten. The CPU must read the data in order to empty the FIFO.

Bit/Field	Name	Type	Reset	Description
2	BE	RO	0	<p>UART Break Error</p> <p>Value Description</p> <p>1 A break condition has been detected, indicating that the receive data input was held Low for longer than a full-word transmission time (defined as start, data, parity, and stop bits).</p> <p>0 No break condition has occurred</p> <p>This bit is cleared to 0 by a write to UARTECR.</p> <p>In FIFO mode, this error is associated with the character at the top of the FIFO. When a break occurs, only one 0 character is loaded into the FIFO. The next character is only enabled after the receive data input goes to a 1 (marking state) and the next valid start bit is received.</p>
1	PE	RO	0	<p>UART Parity Error</p> <p>Value Description</p> <p>1 The parity of the received data character does not match the parity defined by bits 2 and 7 of the UARTLCRH register.</p> <p>0 No parity error has occurred</p> <p>This bit is cleared to 0 by a write to UARTECR.</p>
0	FE	RO	0	<p>UART Framing Error</p> <p>Value Description</p> <p>1 The received character does not have a valid stop bit (a valid stop bit is 1).</p> <p>0 No framing error has occurred</p> <p>This bit is cleared to 0 by a write to UARTECR.</p> <p>In FIFO mode, this error is associated with the character at the top of the FIFO.</p>

Write-Only Error Clear Register

UART Receive Status/Error Clear (UARTRSR/UARTECR)

UART0 base: 0x4000.C000
 UART1 base: 0x4000.D000
 UART2 base: 0x4000.E000
 UART3 base: 0x4000.F000
 UART4 base: 0x4001.0000
 UART5 base: 0x4001.1000
 UART6 base: 0x4001.2000
 UART7 base: 0x4001.3000
 Offset 0x004
 Type WO, reset 0x0000.0000

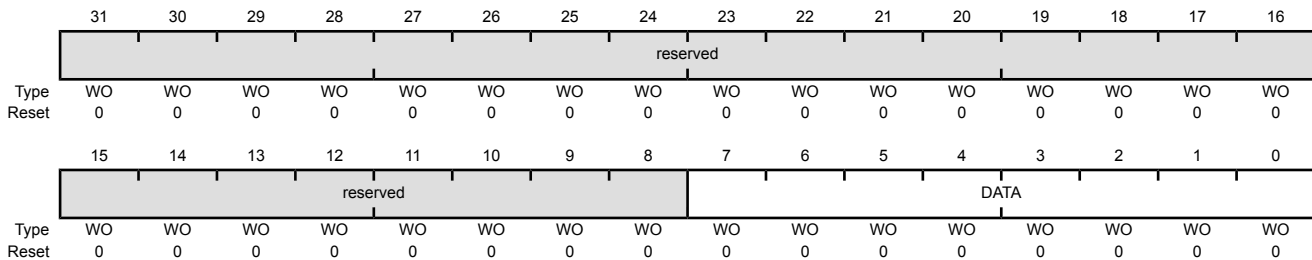

Bit/Field	Name	Type	Reset	Description
31:8	reserved	WO	0x0000.00	Software should not rely on the value of a reserved bit. To provide compatibility with future products, the value of a reserved bit should be preserved across a read-modify-write operation.
7:0	DATA	WO	0x00	Error Clear A write to this register of any data clears the framing, parity, break, and overrun flags.

Register 3: UART Flag (UARTFR), offset 0x018

The **UARTFR** register is the flag register. After reset, the **TXFF**, **RXFF**, and **BUSY** bits are 0, and **TXFE** and **RXFE** bits are 1. The **CTS** bit indicate the modem flow control. Note that the modem bits are only implemented on UART1 and are reserved on UART0 and UART2.

UART Flag (UARTFR)

UART0 base: 0x4000.C000
 UART1 base: 0x4000.D000
 UART2 base: 0x4000.E000
 UART3 base: 0x4000.F000
 UART4 base: 0x4001.0000
 UART5 base: 0x4001.1000
 UART6 base: 0x4001.2000
 UART7 base: 0x4001.3000
 Offset 0x018
 Type RO, reset 0x0000.0090

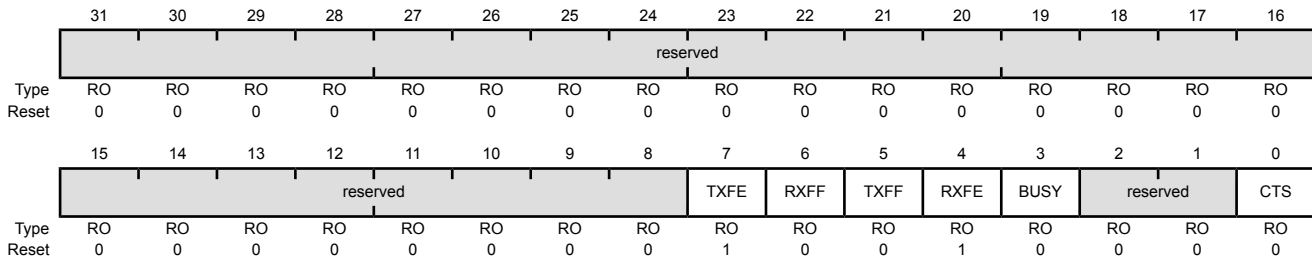

Bit/Field	Name	Type	Reset	Description
31:8	reserved	RO	0x0000.00	Software should not rely on the value of a reserved bit. To provide compatibility with future products, the value of a reserved bit should be preserved across a read-modify-write operation.
7	TXFE	RO	1	UART Transmit FIFO Empty The meaning of this bit depends on the state of the FEN bit in the UARTLCRH register. Value Description 1 If the FIFO is disabled (FEN is 0), the transmit holding register is empty. If the FIFO is enabled (FEN is 1), the transmit FIFO is empty. 0 The transmitter has data to transmit.
6	RXFF	RO	0	UART Receive FIFO Full The meaning of this bit depends on the state of the FEN bit in the UARTLCRH register. Value Description 1 If the FIFO is disabled (FEN is 0), the receive holding register is full. If the FIFO is enabled (FEN is 1), the receive FIFO is full. 0 The receiver can receive data.

Bit/Field	Name	Type	Reset	Description
5	TXFF	RO	0	<p>UART Transmit FIFO Full</p> <p>The meaning of this bit depends on the state of the FEN bit in the UARTLCRH register.</p> <p>Value Description</p> <p>1 If the FIFO is disabled (FEN is 0), the transmit holding register is full.</p> <p>If the FIFO is enabled (FEN is 1), the transmit FIFO is full.</p> <p>0 The transmitter is not full.</p>
4	RXFE	RO	1	<p>UART Receive FIFO Empty</p> <p>The meaning of this bit depends on the state of the FEN bit in the UARTLCRH register.</p> <p>Value Description</p> <p>1 If the FIFO is disabled (FEN is 0), the receive holding register is empty.</p> <p>If the FIFO is enabled (FEN is 1), the receive FIFO is empty.</p> <p>0 The receiver is not empty.</p>
3	BUSY	RO	0	<p>UART Busy</p> <p>Value Description</p> <p>1 The UART is busy transmitting data. This bit remains set until the complete byte, including all stop bits, has been sent from the shift register.</p> <p>0 The UART is not busy.</p> <p>This bit is set as soon as the transmit FIFO becomes non-empty (regardless of whether UART is enabled).</p>
2:1	reserved	RO	0	Software should not rely on the value of a reserved bit. To provide compatibility with future products, the value of a reserved bit should be preserved across a read-modify-write operation.
0	CTS	RO	0	<p>Clear To Send</p> <p>Value Description</p> <p>1 The U1CTS signal is asserted.</p> <p>0 The U1CTS signal is not asserted.</p>

Register 4: UART IrDA Low-Power Register (UARTILPR), offset 0x020

The **UARTILPR** register stores the 8-bit low-power counter divisor value used to derive the low-power SIR pulse width clock by dividing down the system clock (SysClk). All the bits are cleared when reset.

The internal $F_{IrLPBaud16}$ clock is generated by dividing down SysClk according to the low-power divisor value written to **UARTILPR**. The duration of SIR pulses generated when low-power mode is enabled is three times the period of the $F_{IrLPBaud16}$ clock. The low-power divisor value is calculated as follows:

$$ILPDVSR = SysClk / F_{IrLPBaud16}$$

where $F_{IrLPBaud16}$ is nominally 1.8432 MHz.

The divisor must be programmed such that $1.42 \text{ MHz} < F_{IrLPBaud16} < 2.12 \text{ MHz}$, resulting in a low-power pulse duration of 1.41–2.11 μs (three times the period of $F_{IrLPBaud16}$). The minimum frequency of $F_{IrLPBaud16}$ ensures that pulses less than one period of $F_{IrLPBaud16}$ are rejected, but pulses greater than 1.4 μs are accepted as valid pulses.

Note: Zero is an illegal value. Programming a zero value results in no $F_{IrLPBaud16}$ pulses being generated.

UART IrDA Low-Power Register (UARTILPR)

UART0 base: 0x4000.C000
 UART1 base: 0x4000.D000
 UART2 base: 0x4000.E000
 UART3 base: 0x4000.F000
 UART4 base: 0x4001.0000
 UART5 base: 0x4001.1000
 UART6 base: 0x4001.2000
 UART7 base: 0x4001.3000
 Offset 0x020
 Type R/W, reset 0x0000.0000

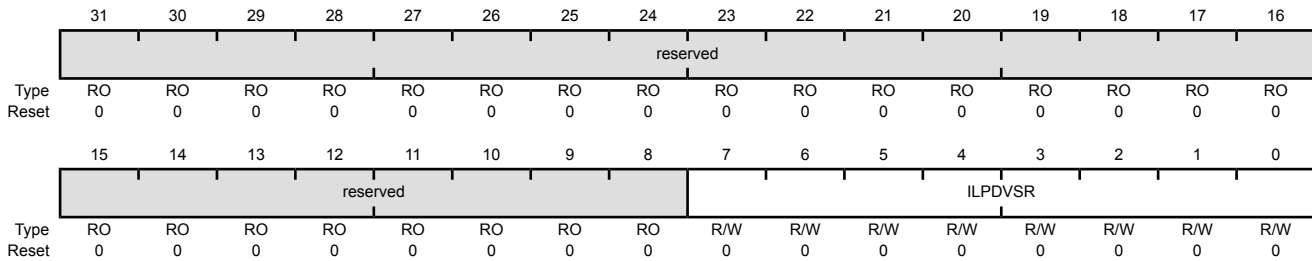

Bit/Field	Name	Type	Reset	Description
31:8	reserved	RO	0x0000.00	Software should not rely on the value of a reserved bit. To provide compatibility with future products, the value of a reserved bit should be preserved across a read-modify-write operation.
7:0	ILPDVSR	R/W	0x00	IrDA Low-Power Divisor This field contains the 8-bit low-power divisor value.

Register 5: UART Integer Baud-Rate Divisor (UARTIBRD), offset 0x024

The **UARTIBRD** register is the integer part of the baud-rate divisor value. All the bits are cleared on reset. The minimum possible divide ratio is 1 (when **UARTIBRD**=0), in which case the **UARTFBRD** register is ignored. When changing the **UARTIBRD** register, the new value does not take effect until transmission/reception of the current character is complete. Any changes to the baud-rate divisor must be followed by a write to the **UARTLCRH** register. See “Baud-Rate Generation” on page 858 for configuration details.

UART Integer Baud-Rate Divisor (UARTIBRD)

UART0 base: 0x4000.C000
 UART1 base: 0x4000.D000
 UART2 base: 0x4000.E000
 UART3 base: 0x4000.F000
 UART4 base: 0x4001.0000
 UART5 base: 0x4001.1000
 UART6 base: 0x4001.2000
 UART7 base: 0x4001.3000
 Offset 0x024
 Type R/W, reset 0x0000.0000

	31	30	29	28	27	26	25	24	23	22	21	20	19	18	17	16
	reserved															
Type	RO	RO	RO	RO	RO	RO	RO	RO	RO	RO	RO	RO	RO	RO	RO	RO
Reset	0	0	0	0	0	0	0	0	0	0	0	0	0	0	0	0
	15	14	13	12	11	10	9	8	7	6	5	4	3	2	1	0
	DIVINT															
Type	R/W	R/W	R/W	R/W	R/W	R/W	R/W	R/W	R/W	R/W	R/W	R/W	R/W	R/W	R/W	R/W
Reset	0	0	0	0	0	0	0	0	0	0	0	0	0	0	0	0

Bit/Field	Name	Type	Reset	Description
31:16	reserved	RO	0x0000	Software should not rely on the value of a reserved bit. To provide compatibility with future products, the value of a reserved bit should be preserved across a read-modify-write operation.
15:0	DIVINT	R/W	0x0000	Integer Baud-Rate Divisor

Register 6: UART Fractional Baud-Rate Divisor (UARTFBRD), offset 0x028

The **UARTFBRD** register is the fractional part of the baud-rate divisor value. All the bits are cleared on reset. When changing the **UARTFBRD** register, the new value does not take effect until transmission/reception of the current character is complete. Any changes to the baud-rate divisor must be followed by a write to the **UARTLCRH** register. See “Baud-Rate Generation” on page 858 for configuration details.

UART Fractional Baud-Rate Divisor (UARTFBRD)

UART0 base: 0x4000.C000
 UART1 base: 0x4000.D000
 UART2 base: 0x4000.E000
 UART3 base: 0x4000.F000
 UART4 base: 0x4001.0000
 UART5 base: 0x4001.1000
 UART6 base: 0x4001.2000
 UART7 base: 0x4001.3000
 Offset 0x028
 Type R/W, reset 0x0000.0000

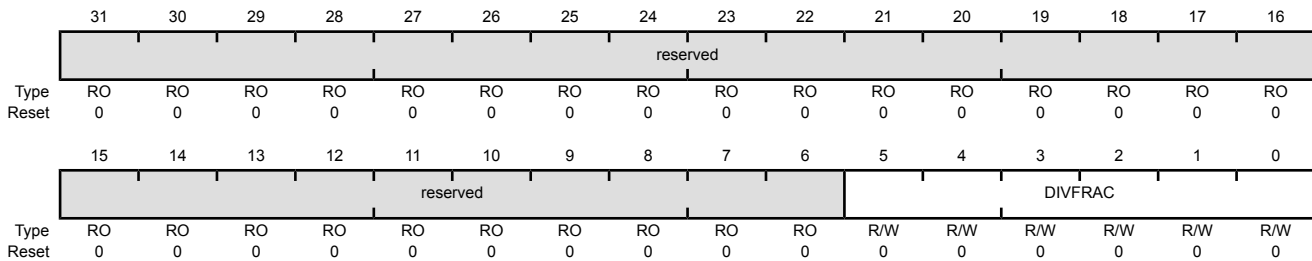

Bit/Field	Name	Type	Reset	Description
31:6	reserved	RO	0x0000.000	Software should not rely on the value of a reserved bit. To provide compatibility with future products, the value of a reserved bit should be preserved across a read-modify-write operation.
5:0	DIVFRAC	R/W	0x0	Fractional Baud-Rate Divisor

Register 7: UART Line Control (UARTLCRH), offset 0x02C

The **UARTLCRH** register is the line control register. Serial parameters such as data length, parity, and stop bit selection are implemented in this register.

When updating the baud-rate divisor (**UARTIBRD** and/or **UARTIFRD**), the **UARTLCRH** register must also be written. The write strobe for the baud-rate divisor registers is tied to the **UARTLCRH** register.

UART Line Control (UARTLCRH)

UART0 base: 0x4000.C000
 UART1 base: 0x4000.D000
 UART2 base: 0x4000.E000
 UART3 base: 0x4000.F000
 UART4 base: 0x4001.0000
 UART5 base: 0x4001.1000
 UART6 base: 0x4001.2000
 UART7 base: 0x4001.3000
 Offset 0x02C
 Type R/W, reset 0x0000.0000

	31	30	29	28	27	26	25	24	23	22	21	20	19	18	17	16
	reserved															
Type	RO	RO	RO	RO	RO	RO	RO	RO	RO	RO	RO	RO	RO	RO	RO	RO
Reset	0	0	0	0	0	0	0	0	0	0	0	0	0	0	0	0
	15	14	13	12	11	10	9	8	7	6	5	4	3	2	1	0
	reserved								SPS	WLEN		FEN	STP2	EPS	PEN	BRK
Type	RO	RO	RO	RO	RO	RO	RO	RO	R/W	R/W	R/W	R/W	R/W	R/W	R/W	R/W
Reset	0	0	0	0	0	0	0	0	0	0	0	0	0	0	0	0

Bit/Field	Name	Type	Reset	Description										
31:8	reserved	RO	0x0000.00	Software should not rely on the value of a reserved bit. To provide compatibility with future products, the value of a reserved bit should be preserved across a read-modify-write operation.										
7	SPS	R/W	0	UART Stick Parity Select When bits 1, 2, and 7 of UARTLCRH are set, the parity bit is transmitted and checked as a 0. When bits 1 and 7 are set and 2 is cleared, the parity bit is transmitted and checked as a 1. When this bit is cleared, stick parity is disabled.										
6:5	WLEN	R/W	0x0	UART Word Length The bits indicate the number of data bits transmitted or received in a frame as follows: <table border="1" style="margin-left: 20px;"> <thead> <tr> <th>Value</th> <th>Description</th> </tr> </thead> <tbody> <tr> <td>0x0</td> <td>5 bits (default)</td> </tr> <tr> <td>0x1</td> <td>6 bits</td> </tr> <tr> <td>0x2</td> <td>7 bits</td> </tr> <tr> <td>0x3</td> <td>8 bits</td> </tr> </tbody> </table>	Value	Description	0x0	5 bits (default)	0x1	6 bits	0x2	7 bits	0x3	8 bits
Value	Description													
0x0	5 bits (default)													
0x1	6 bits													
0x2	7 bits													
0x3	8 bits													

Bit/Field	Name	Type	Reset	Description
4	FEN	R/W	0	<p>UART Enable FIFOs</p> <p>Value Description</p> <p>1 The transmit and receive FIFO buffers are enabled (FIFO mode).</p> <p>0 The FIFOs are disabled (Character mode). The FIFOs become 1-byte-deep holding registers.</p>
3	STP2	R/W	0	<p>UART Two Stop Bits Select</p> <p>Value Description</p> <p>1 Two stop bits are transmitted at the end of a frame. The receive logic does not check for two stop bits being received. When in 7816 smartcard mode (the <code>SMART</code> bit is set in the <code>UARTCTL</code> register), the number of stop bits is forced to 2.</p> <p>0 One stop bit is transmitted at the end of a frame.</p>
2	EPS	R/W	0	<p>UART Even Parity Select</p> <p>Value Description</p> <p>1 Even parity generation and checking is performed during transmission and reception, which checks for an even number of 1s in data and parity bits.</p> <p>0 Odd parity is performed, which checks for an odd number of 1s.</p> <p>This bit has no effect when parity is disabled by the <code>PEN</code> bit.</p>
1	PEN	R/W	0	<p>UART Parity Enable</p> <p>Value Description</p> <p>1 Parity checking and generation is enabled.</p> <p>0 Parity is disabled and no parity bit is added to the data frame.</p>
0	BRK	R/W	0	<p>UART Send Break</p> <p>Value Description</p> <p>1 A Low level is continually output on the <code>UnTx</code> signal, after completing transmission of the current character. For the proper execution of the break command, software must set this bit for at least two frames (character periods).</p> <p>0 Normal use.</p>

Register 8: UART Control (UARTCTL), offset 0x030

The **UARTCTL** register is the control register. All the bits are cleared on reset except for the Transmit Enable (**TXE**) and Receive Enable (**RXE**) bits, which are set.

To enable the UART module, the **UARTEN** bit must be set. If software requires a configuration change in the module, the **UARTEN** bit must be cleared before the configuration changes are written. If the UART is disabled during a transmit or receive operation, the current transaction is completed prior to the UART stopping.

Note: The **UARTCTL** register should not be changed while the UART is enabled or else the results are unpredictable. The following sequence is recommended for making changes to the **UARTCTL** register.

1. Disable the UART.
2. Wait for the end of transmission or reception of the current character.
3. Flush the transmit FIFO by clearing bit 4 (**FEN**) in the line control register (**UARTLCRH**).
4. Reprogram the control register.
5. Enable the UART.

UART Control (UARTCTL)

UART0 base: 0x4000.C000
 UART1 base: 0x4000.D000
 UART2 base: 0x4000.E000
 UART3 base: 0x4000.F000
 UART4 base: 0x4001.0000
 UART5 base: 0x4001.1000
 UART6 base: 0x4001.2000
 UART7 base: 0x4001.3000
 Offset 0x030
 Type R/W, reset 0x0000.0300

	31	30	29	28	27	26	25	24	23	22	21	20	19	18	17	16
	reserved															
Type	RO	RO	RO	RO	RO	RO	RO	RO	RO	RO	RO	RO	RO	RO	RO	RO
Reset	0	0	0	0	0	0	0	0	0	0	0	0	0	0	0	0
	15	14	13	12	11	10	9	8	7	6	5	4	3	2	1	0
	reserved						RXE	TXE	LBE	LIN	HSE	EOT	SMART	SIRLP	SIREN	UARTEN
Type	RO	RO	RO	RO	RO	RO	R/W	R/W	R/W	R/W	R/W	R/W	R/W	R/W	R/W	R/W
Reset	0	0	0	0	0	0	1	1	0	0	0	0	0	0	0	0

Bit/Field	Name	Type	Reset	Description
31:10	reserved	RO	0x0000	Software should not rely on the value of a reserved bit. To provide compatibility with future products, the value of a reserved bit should be preserved across a read-modify-write operation.

Bit/Field	Name	Type	Reset	Description
9	RXE	R/W	1	<p>UART Receive Enable</p> <p>Value Description</p> <p>1 The receive section of the UART is enabled.</p> <p>0 The receive section of the UART is disabled.</p> <p>If the UART is disabled in the middle of a receive, it completes the current character before stopping.</p> <p>Note: To enable reception, the <code>UARTEN</code> bit must also be set.</p>
8	TXE	R/W	1	<p>UART Transmit Enable</p> <p>Value Description</p> <p>1 The transmit section of the UART is enabled.</p> <p>0 The transmit section of the UART is disabled.</p> <p>If the UART is disabled in the middle of a transmission, it completes the current character before stopping.</p> <p>Note: To enable transmission, the <code>UARTEN</code> bit must also be set.</p>
7	LBE	R/W	0	<p>UART Loop Back Enable</p> <p>Value Description</p> <p>1 The <code>UnTx</code> path is fed through the <code>UnRx</code> path.</p> <p>0 Normal operation.</p>
6	LIN	R/W	0	<p>LIN Mode Enable</p> <p>Value Description</p> <p>1 The UART operates in LIN mode.</p> <p>0 Normal operation.</p>
5	HSE	R/W	0	<p>High-Speed Enable</p> <p>Value Description</p> <p>0 The UART is clocked using the system clock divided by 16.</p> <p>1 The UART is clocked using the system clock divided by 8.</p> <p>Note: System clock used is also dependent on the baud-rate divisor configuration (see page 877) and page 878).</p> <p>The state of this bit has no effect on clock generation in ISO 7816 smart card mode (the <code>SMART</code> bit is set).</p>

Bit/Field	Name	Type	Reset	Description
4	EOT	R/W	0	<p>End of Transmission</p> <p>This bit determines the behavior of the <code>TXRIS</code> bit in the <code>UARTRIS</code> register.</p> <p>Value Description</p> <p>1 The <code>TXRIS</code> bit is set only after all transmitted data, including stop bits, have cleared the serializer.</p> <p>0 The <code>TXRIS</code> bit is set when the transmit FIFO condition specified in <code>UARTIFLS</code> is met.</p>
3	SMART	R/W	0	<p>ISO 7816 Smart Card Support</p> <p>Value Description</p> <p>1 The UART operates in Smart Card mode.</p> <p>0 Normal operation.</p> <p>The application must ensure that it sets 8-bit word length (<code>WLEN</code> set to 0x3) and even parity (<code>PEN</code> set to 1, <code>EPS</code> set to 1, <code>SPS</code> set to 0) in <code>UARTLCRH</code> when using ISO 7816 mode.</p> <p>In this mode, the value of the <code>STP2</code> bit in <code>UARTLCRH</code> is ignored and the number of stop bits is forced to 2. Note that the UART does not support automatic retransmission on parity errors. If a parity error is detected on transmission, all further transmit operations are aborted and software must handle retransmission of the affected byte or message.</p>
2	SIRLP	R/W	0	<p>UART SIR Low-Power Mode</p> <p>This bit selects the IrDA encoding mode.</p> <p>Value Description</p> <p>1 The UART operates in SIR Low-Power mode. Low-level bits are transmitted with a pulse width which is 3 times the period of the <code>IrLPBaud16</code> input signal, regardless of the selected bit rate.</p> <p>0 Low-level bits are transmitted as an active High pulse with a width of 3/16th of the bit period.</p> <p>Setting this bit uses less power, but might reduce transmission distances. See page 876 for more information.</p>
1	SIREN	R/W	0	<p>UART SIR Enable</p> <p>Value Description</p> <p>1 The IrDA SIR block is enabled, and the UART will transmit and receive data using SIR protocol.</p> <p>0 Normal operation.</p>

Bit/Field	Name	Type	Reset	Description
0	UARTEN	R/W	0	UART Enable

Value Description

1 The UART is enabled.

0 The UART is disabled.

If the UART is disabled in the middle of transmission or reception, it completes the current character before stopping.

Register 9: UART Interrupt FIFO Level Select (UARTIFLS), offset 0x034

The **UARTIFLS** register is the interrupt FIFO level select register. You can use this register to define the FIFO level at which the **TXRIS** and **RXRIS** bits in the **UARTRIS** register are triggered.

The interrupts are generated based on a transition through a level rather than being based on the level. That is, the interrupts are generated when the fill level progresses through the trigger level. For example, if the receive trigger level is set to the half-way mark, the interrupt is triggered as the module is receiving the 9th character.

Out of reset, the **TXIFLSEL** and **RXIFLSEL** bits are configured so that the FIFOs trigger an interrupt at the half-way mark.

UART Interrupt FIFO Level Select (UARTIFLS)

UART0 base: 0x4000.C000
 UART1 base: 0x4000.D000
 UART2 base: 0x4000.E000
 UART3 base: 0x4000.F000
 UART4 base: 0x4001.0000
 UART5 base: 0x4001.1000
 UART6 base: 0x4001.2000
 UART7 base: 0x4001.3000
 Offset 0x034
 Type R/W, reset 0x0000.0012

	31	30	29	28	27	26	25	24	23	22	21	20	19	18	17	16
	reserved															
Type	RO	RO	RO	RO	RO	RO	RO	RO	RO	RO	RO	RO	RO	RO	RO	RO
Reset	0	0	0	0	0	0	0	0	0	0	0	0	0	0	0	0
	15	14	13	12	11	10	9	8	7	6	5	4	3	2	1	0
	reserved											RXIFLSEL		TXIFLSEL		
Type	RO	RO	RO	RO	RO	RO	RO	RO	RO	RO	R/W	R/W	R/W	R/W	R/W	R/W
Reset	0	0	0	0	0	0	0	0	0	0	0	1	0	0	1	0

Bit/Field	Name	Type	Reset	Description														
31:6	reserved	RO	0x0000.00	Software should not rely on the value of a reserved bit. To provide compatibility with future products, the value of a reserved bit should be preserved across a read-modify-write operation.														
5:3	RXIFLSEL	R/W	0x2	UART Receive Interrupt FIFO Level Select The trigger points for the receive interrupt are as follows: <table border="1"> <thead> <tr> <th>Value</th> <th>Description</th> </tr> </thead> <tbody> <tr> <td>0x0</td> <td>RX FIFO $\geq \frac{1}{8}$ full</td> </tr> <tr> <td>0x1</td> <td>RX FIFO $\geq \frac{1}{4}$ full</td> </tr> <tr> <td>0x2</td> <td>RX FIFO $\geq \frac{1}{2}$ full (default)</td> </tr> <tr> <td>0x3</td> <td>RX FIFO $\geq \frac{3}{4}$ full</td> </tr> <tr> <td>0x4</td> <td>RX FIFO $\geq \frac{7}{8}$ full</td> </tr> <tr> <td>0x5-0x7</td> <td>Reserved</td> </tr> </tbody> </table>	Value	Description	0x0	RX FIFO $\geq \frac{1}{8}$ full	0x1	RX FIFO $\geq \frac{1}{4}$ full	0x2	RX FIFO $\geq \frac{1}{2}$ full (default)	0x3	RX FIFO $\geq \frac{3}{4}$ full	0x4	RX FIFO $\geq \frac{7}{8}$ full	0x5-0x7	Reserved
Value	Description																	
0x0	RX FIFO $\geq \frac{1}{8}$ full																	
0x1	RX FIFO $\geq \frac{1}{4}$ full																	
0x2	RX FIFO $\geq \frac{1}{2}$ full (default)																	
0x3	RX FIFO $\geq \frac{3}{4}$ full																	
0x4	RX FIFO $\geq \frac{7}{8}$ full																	
0x5-0x7	Reserved																	

Bit/Field	Name	Type	Reset	Description
2:0	TXIFLSEL	R/W	0x2	UART Transmit Interrupt FIFO Level Select The trigger points for the transmit interrupt are as follows:

Value	Description
0x0	TX FIFO \leq $\frac{7}{8}$ empty
0x1	TX FIFO \leq $\frac{3}{4}$ empty
0x2	TX FIFO \leq $\frac{1}{2}$ empty (default)
0x3	TX FIFO \leq $\frac{1}{4}$ empty
0x4	TX FIFO \leq $\frac{1}{8}$ empty
0x5-0x7	Reserved

Note: If the `EOT` bit in `UARTCTL` is set (see page 881), the transmit interrupt is generated once the FIFO is completely empty and all data including stop bits have left the transmit serializer. In this case, the setting of `TXIFLSEL` is ignored.

Register 10: UART Interrupt Mask (UARTIM), offset 0x038

The **UARTIM** register is the interrupt mask set/clear register.

On a read, this register gives the current value of the mask on the relevant interrupt. Setting a bit allows the corresponding raw interrupt signal to be routed to the interrupt controller. Clearing a bit prevents the raw interrupt signal from being sent to the interrupt controller.

UART Interrupt Mask (UARTIM)

UART0 base: 0x4000.C000
 UART1 base: 0x4000.D000
 UART2 base: 0x4000.E000
 UART3 base: 0x4000.F000
 UART4 base: 0x4001.0000
 UART5 base: 0x4001.1000
 UART6 base: 0x4001.2000
 UART7 base: 0x4001.3000
 Offset 0x038
 Type R/W, reset 0x0000.0000

	31	30	29	28	27	26	25	24	23	22	21	20	19	18	17	16
	reserved															
Type	RO	RO	RO	RO	RO	RO	RO	RO	RO	RO	RO	RO	RO	RO	RO	RO
Reset	0	0	0	0	0	0	0	0	0	0	0	0	0	0	0	0
	15	14	13	12	11	10	9	8	7	6	5	4	3	2	1	0
	LME5IM	LME1IM	LMSBIM	9BITIM	reserved	OEIM	BEIM	PEIM	FEIM	RTIM	TXIM	RXIM	reserved	CTSIM	reserved	
Type	R/W	R/W	R/W	R/W	RO	R/W	R/W	R/W	R/W	R/W	R/W	R/W	RO	RO	R/W	RO
Reset	0	0	0	0	0	0	0	0	0	0	0	0	0	0	0	0

Bit/Field	Name	Type	Reset	Description
31:16	reserved	RO	0	Software should not rely on the value of a reserved bit. To provide compatibility with future products, the value of a reserved bit should be preserved across a read-modify-write operation.
15	LME5IM	R/W	0	LIN Mode Edge 5 Interrupt Mask Value Description 1 An interrupt is sent to the interrupt controller when the LME5RIS bit in the UARTRIS register is set. 0 The LME5RIS interrupt is suppressed and not sent to the interrupt controller.
14	LME1IM	R/W	0	LIN Mode Edge 1 Interrupt Mask Value Description 1 An interrupt is sent to the interrupt controller when the LME1RIS bit in the UARTRIS register is set. 0 The LME1RIS interrupt is suppressed and not sent to the interrupt controller.

Bit/Field	Name	Type	Reset	Description
13	LMSBIM	R/W	0	<p>LIN Mode Sync Break Interrupt Mask</p> <p>Value Description</p> <p>1 An interrupt is sent to the interrupt controller when the LMSBRIS bit in the UARTRIS register is set.</p> <p>0 The LMSBRIS interrupt is suppressed and not sent to the interrupt controller.</p>
12	9BITIM	R/W	0	<p>9-Bit Mode Interrupt Mask</p> <p>Value Description</p> <p>1 An interrupt is sent to the interrupt controller when the 9BITRIS bit in the UARTRIS register is set.</p> <p>0 The 9BITRIS interrupt is suppressed and not sent to the interrupt controller.</p>
11	reserved	RO	0	Software should not rely on the value of a reserved bit. To provide compatibility with future products, the value of a reserved bit should be preserved across a read-modify-write operation.
10	OEIM	R/W	0	<p>UART Overrun Error Interrupt Mask</p> <p>Value Description</p> <p>1 An interrupt is sent to the interrupt controller when the OERIS bit in the UARTRIS register is set.</p> <p>0 The OERIS interrupt is suppressed and not sent to the interrupt controller.</p>
9	BEIM	R/W	0	<p>UART Break Error Interrupt Mask</p> <p>Value Description</p> <p>1 An interrupt is sent to the interrupt controller when the BERIS bit in the UARTRIS register is set.</p> <p>0 The BERIS interrupt is suppressed and not sent to the interrupt controller.</p>
8	PEIM	R/W	0	<p>UART Parity Error Interrupt Mask</p> <p>Value Description</p> <p>1 An interrupt is sent to the interrupt controller when the PERIS bit in the UARTRIS register is set.</p> <p>0 The PERIS interrupt is suppressed and not sent to the interrupt controller.</p>

Bit/Field	Name	Type	Reset	Description
7	FEIM	R/W	0	UART Framing Error Interrupt Mask Value Description 1 An interrupt is sent to the interrupt controller when the <code>FERIS</code> bit in the UARTRIS register is set. 0 The <code>FERIS</code> interrupt is suppressed and not sent to the interrupt controller.
6	RTIM	R/W	0	UART Receive Time-Out Interrupt Mask Value Description 1 An interrupt is sent to the interrupt controller when the <code>RTRIS</code> bit in the UARTRIS register is set. 0 The <code>RTRIS</code> interrupt is suppressed and not sent to the interrupt controller.
5	TXIM	R/W	0	UART Transmit Interrupt Mask Value Description 1 An interrupt is sent to the interrupt controller when the <code>TXRIS</code> bit in the UARTRIS register is set. 0 The <code>TXRIS</code> interrupt is suppressed and not sent to the interrupt controller.
4	RXIM	R/W	0	UART Receive Interrupt Mask Value Description 1 An interrupt is sent to the interrupt controller when the <code>RXRIS</code> bit in the UARTRIS register is set. 0 The <code>RXRIS</code> interrupt is suppressed and not sent to the interrupt controller.
3:2	reserved	RO	0	Software should not rely on the value of a reserved bit. To provide compatibility with future products, the value of a reserved bit should be preserved across a read-modify-write operation.
1	CTSIM	R/W	0	UART Clear to Send Modem Interrupt Mask Value Description 1 An interrupt is sent to the interrupt controller when the <code>CTSRIS</code> bit in the UARTRIS register is set. 0 The <code>CTSRIS</code> interrupt is suppressed and not sent to the interrupt controller. This bit is implemented only on UART1 and is reserved for UART0 and UART2.
0	reserved	RO	0	Software should not rely on the value of a reserved bit. To provide compatibility with future products, the value of a reserved bit should be preserved across a read-modify-write operation.

Register 11: UART Raw Interrupt Status (UARTRIS), offset 0x03C

The **UARTRIS** register is the raw interrupt status register. On a read, this register gives the current raw status value of the corresponding interrupt. A write has no effect.

UART Raw Interrupt Status (UARTRIS)

UART0 base: 0x4000.C000
 UART1 base: 0x4000.D000
 UART2 base: 0x4000.E000
 UART3 base: 0x4000.F000
 UART4 base: 0x4001.0000
 UART5 base: 0x4001.1000
 UART6 base: 0x4001.2000
 UART7 base: 0x4001.3000
 Offset 0x03C
 Type RO, reset 0x0000.000F

	31	30	29	28	27	26	25	24	23	22	21	20	19	18	17	16
	reserved															
Type	RO	RO	RO	RO	RO	RO	RO	RO	RO	RO	RO	RO	RO	RO	RO	RO
Reset	0	0	0	0	0	0	0	0	0	0	0	0	0	0	0	0
	15	14	13	12	11	10	9	8	7	6	5	4	3	2	1	0
	LME5RIS	LME1RIS	LMSBRIS	9BITRIS	reserved	OERIS	BERIS	PERIS	FERIS	RTRIS	TXRIS	RXRIS	reserved	CTSRRIS	reserved	
Type	RO	RO	RO	R/W	RO	RO	RO	RO	RO	RO	RO	RO	RO	RO	RO	RO
Reset	0	0	0	0	0	0	0	0	0	0	0	0	0	0	0	0

Bit/Field	Name	Type	Reset	Description
31:16	reserved	RO	0	Software should not rely on the value of a reserved bit. To provide compatibility with future products, the value of a reserved bit should be preserved across a read-modify-write operation.
15	LME5RIS	RO	0	LIN Mode Edge 5 Raw Interrupt Status Value Description 1 The timer value at the 5th falling edge of the LIN Sync Field has been captured. 0 No interrupt This bit is cleared by writing a 1 to the LME5IC bit in the UARTICR register.
14	LME1RIS	RO	0	LIN Mode Edge 1 Raw Interrupt Status Value Description 1 The timer value at the 1st falling edge of the LIN Sync Field has been captured. 0 No interrupt This bit is cleared by writing a 1 to the LME1IC bit in the UARTICR register.
13	LMSBRIS	RO	0	LIN Mode Sync Break Raw Interrupt Status Value Description 1 A LIN Sync Break has been detected. 0 No interrupt This bit is cleared by writing a 1 to the LMSBIC bit in the UARTICR register.

Bit/Field	Name	Type	Reset	Description
12	9BITRIS	R/W	0	<p>9-Bit Mode Raw Interrupt Status</p> <p>Value Description</p> <p>1 A receive address match has occurred.</p> <p>0 No interrupt</p> <p>This bit is cleared by writing a 1 to the 9BITIC bit in the UARTICR register.</p>
11	reserved	RO	0	Software should not rely on the value of a reserved bit. To provide compatibility with future products, the value of a reserved bit should be preserved across a read-modify-write operation.
10	OERIS	RO	0	<p>UART Overrun Error Raw Interrupt Status</p> <p>Value Description</p> <p>1 An overrun error has occurred.</p> <p>0 No interrupt</p> <p>This bit is cleared by writing a 1 to the OEIC bit in the UARTICR register.</p>
9	BERIS	RO	0	<p>UART Break Error Raw Interrupt Status</p> <p>Value Description</p> <p>1 A break error has occurred.</p> <p>0 No interrupt</p> <p>This bit is cleared by writing a 1 to the BEIC bit in the UARTICR register.</p>
8	PERIS	RO	0	<p>UART Parity Error Raw Interrupt Status</p> <p>Value Description</p> <p>1 A parity error has occurred.</p> <p>0 No interrupt</p> <p>This bit is cleared by writing a 1 to the PEIC bit in the UARTICR register.</p>
7	FERIS	RO	0	<p>UART Framing Error Raw Interrupt Status</p> <p>Value Description</p> <p>1 A framing error has occurred.</p> <p>0 No interrupt</p> <p>This bit is cleared by writing a 1 to the FEIC bit in the UARTICR register.</p>
6	RTRIS	RO	0	<p>UART Receive Time-Out Raw Interrupt Status</p> <p>Value Description</p> <p>1 A receive time out has occurred.</p> <p>0 No interrupt</p> <p>This bit is cleared by writing a 1 to the RTIC bit in the UARTICR register.</p>

Bit/Field	Name	Type	Reset	Description
5	TXRIS	RO	0	<p>UART Transmit Raw Interrupt Status</p> <p>Value Description</p> <p>1 If the EOT bit in the UARTCTL register is clear, the transmit FIFO level has passed through the condition defined in the UARTIFLS register.</p> <p>If the EOT bit is set, the last bit of all transmitted data and flags has left the serializer.</p> <p>0 No interrupt</p> <p>This bit is cleared by writing a 1 to the TXIC bit in the UARTICR register or by writing data to the transmit FIFO until it becomes greater than the trigger level, if the FIFO is enabled, or by writing a single byte if the FIFO is disabled.</p>
4	RXRIS	RO	0	<p>UART Receive Raw Interrupt Status</p> <p>Value Description</p> <p>1 The receive FIFO level has passed through the condition defined in the UARTIFLS register.</p> <p>0 No interrupt</p> <p>This bit is cleared by writing a 1 to the RXIC bit in the UARTICR register or by reading data from the receive FIFO until it becomes less than the trigger level, if the FIFO is enabled, or by reading a single byte if the FIFO is disabled.</p>
3:2	reserved	RO	0	Software should not rely on the value of a reserved bit. To provide compatibility with future products, the value of a reserved bit should be preserved across a read-modify-write operation.
1	CTSRIS	RO	0	<p>UART Clear to Send Modem Raw Interrupt Status</p> <p>Value Description</p> <p>1 Clear to Send used for software flow control.</p> <p>0 No interrupt</p> <p>This bit is cleared by writing a 1 to the CTSIC bit in the UARTICR register.</p> <p>This bit is implemented only on UART1 and is reserved for UART0 and UART2.</p>
0	reserved	RO	0	Software should not rely on the value of a reserved bit. To provide compatibility with future products, the value of a reserved bit should be preserved across a read-modify-write operation.

Register 12: UART Masked Interrupt Status (UARTMIS), offset 0x040

The **UARTMIS** register is the masked interrupt status register. On a read, this register gives the current masked status value of the corresponding interrupt. A write has no effect.

UART Masked Interrupt Status (UARTMIS)

UART0 base: 0x4000.C000
 UART1 base: 0x4000.D000
 UART2 base: 0x4000.E000
 UART3 base: 0x4000.F000
 UART4 base: 0x4001.0000
 UART5 base: 0x4001.1000
 UART6 base: 0x4001.2000
 UART7 base: 0x4001.3000
 Offset 0x040
 Type RO, reset 0x0000.0000

	31	30	29	28	27	26	25	24	23	22	21	20	19	18	17	16
	reserved															
Type	RO	RO	RO	RO	RO	RO	RO	RO	RO	RO	RO	RO	RO	RO	RO	RO
Reset	0	0	0	0	0	0	0	0	0	0	0	0	0	0	0	0
	15	14	13	12	11	10	9	8	7	6	5	4	3	2	1	0
	LME5MIS	LME1MIS	LMSBMIS	9BITMIS	reserved	OEMIS	BEMIS	PEMIS	FEMIS	RTMIS	TXMIS	RXMIS	reserved	CTSMIS	reserved	
Type	RO	RO	RO	R/W	RO	RO	RO	RO	RO	RO	RO	RO	RO	RO	RO	RO
Reset	0	0	0	0	0	0	0	0	0	0	0	0	0	0	0	0

Bit/Field	Name	Type	Reset	Description
31:16	reserved	RO	0	Software should not rely on the value of a reserved bit. To provide compatibility with future products, the value of a reserved bit should be preserved across a read-modify-write operation.
15	LME5MIS	RO	0	LIN Mode Edge 5 Masked Interrupt Status Value Description 1 An unmasked interrupt was signaled due to the 5th falling edge of the LIN Sync Field. 0 An interrupt has not occurred or is masked. This bit is cleared by writing a 1 to the LME5IC bit in the UARTICR register.
14	LME1MIS	RO	0	LIN Mode Edge 1 Masked Interrupt Status Value Description 1 An unmasked interrupt was signaled due to the 1st falling edge of the LIN Sync Field. 0 An interrupt has not occurred or is masked. This bit is cleared by writing a 1 to the LME1IC bit in the UARTICR register.

Bit/Field	Name	Type	Reset	Description
13	LMSBMIS	RO	0	<p>LIN Mode Sync Break Masked Interrupt Status</p> <p>Value Description</p> <p>1 An unmasked interrupt was signaled due to the receipt of a LIN Sync Break.</p> <p>0 An interrupt has not occurred or is masked.</p> <p>This bit is cleared by writing a 1 to the <code>LMSBIC</code> bit in the UARTICR register.</p>
12	9BITMIS	R/W	0	<p>9-Bit Mode Masked Interrupt Status</p> <p>Value Description</p> <p>1 An unmasked interrupt was signaled due to a receive address match.</p> <p>0 An interrupt has not occurred or is masked.</p> <p>This bit is cleared by writing a 1 to the <code>9BITIC</code> bit in the UARTICR register.</p>
11	reserved	RO	0	<p>Software should not rely on the value of a reserved bit. To provide compatibility with future products, the value of a reserved bit should be preserved across a read-modify-write operation.</p>
10	OEMIS	RO	0	<p>UART Overrun Error Masked Interrupt Status</p> <p>Value Description</p> <p>1 An unmasked interrupt was signaled due to an overrun error.</p> <p>0 An interrupt has not occurred or is masked.</p> <p>This bit is cleared by writing a 1 to the <code>OEIC</code> bit in the UARTICR register.</p>
9	BEMIS	RO	0	<p>UART Break Error Masked Interrupt Status</p> <p>Value Description</p> <p>1 An unmasked interrupt was signaled due to a break error.</p> <p>0 An interrupt has not occurred or is masked.</p> <p>This bit is cleared by writing a 1 to the <code>BEIC</code> bit in the UARTICR register.</p>
8	PEMIS	RO	0	<p>UART Parity Error Masked Interrupt Status</p> <p>Value Description</p> <p>1 An unmasked interrupt was signaled due to a parity error.</p> <p>0 An interrupt has not occurred or is masked.</p> <p>This bit is cleared by writing a 1 to the <code>PEIC</code> bit in the UARTICR register.</p>
7	FEMIS	RO	0	<p>UART Framing Error Masked Interrupt Status</p> <p>Value Description</p> <p>1 An unmasked interrupt was signaled due to a framing error.</p> <p>0 An interrupt has not occurred or is masked.</p> <p>This bit is cleared by writing a 1 to the <code>FEIC</code> bit in the UARTICR register.</p>

Bit/Field	Name	Type	Reset	Description
6	RTMIS	RO	0	<p>UART Receive Time-Out Masked Interrupt Status</p> <p>Value Description</p> <p>1 An unmasked interrupt was signaled due to a receive time out.</p> <p>0 An interrupt has not occurred or is masked.</p> <p>This bit is cleared by writing a 1 to the <code>RTIC</code> bit in the <code>UARTICR</code> register.</p>
5	TXMIS	RO	0	<p>UART Transmit Masked Interrupt Status</p> <p>Value Description</p> <p>1 An unmasked interrupt was signaled due to passing through the specified transmit FIFO level (if the <code>EOT</code> bit is clear) or due to the transmission of the last data bit (if the <code>EOT</code> bit is set).</p> <p>0 An interrupt has not occurred or is masked.</p> <p>This bit is cleared by writing a 1 to the <code>TXIC</code> bit in the <code>UARTICR</code> register or by writing data to the transmit FIFO until it becomes greater than the trigger level, if the FIFO is enabled, or by writing a single byte if the FIFO is disabled.</p>
4	RXMIS	RO	0	<p>UART Receive Masked Interrupt Status</p> <p>Value Description</p> <p>1 An unmasked interrupt was signaled due to passing through the specified receive FIFO level.</p> <p>0 An interrupt has not occurred or is masked.</p> <p>This bit is cleared by writing a 1 to the <code>RXIC</code> bit in the <code>UARTICR</code> register or by reading data from the receive FIFO until it becomes less than the trigger level, if the FIFO is enabled, or by reading a single byte if the FIFO is disabled.</p>
3:2	reserved	RO	0	Software should not rely on the value of a reserved bit. To provide compatibility with future products, the value of a reserved bit should be preserved across a read-modify-write operation.
1	CTSMIS	RO	0	<p>UART Clear to Send Modem Masked Interrupt Status</p> <p>Value Description</p> <p>1 An unmasked interrupt was signaled due to Clear to Send.</p> <p>0 An interrupt has not occurred or is masked.</p> <p>This bit is cleared by writing a 1 to the <code>CTSIC</code> bit in the <code>UARTICR</code> register.</p> <p>This bit is implemented only on UART1 and is reserved for UART0 and UART2.</p>
0	reserved	RO	0	Software should not rely on the value of a reserved bit. To provide compatibility with future products, the value of a reserved bit should be preserved across a read-modify-write operation.

Register 13: UART Interrupt Clear (UARTICR), offset 0x044

The **UARTICR** register is the interrupt clear register. On a write of 1, the corresponding interrupt (both raw interrupt and masked interrupt, if enabled) is cleared. A write of 0 has no effect.

UART Interrupt Clear (UARTICR)

UART0 base: 0x4000.C000
 UART1 base: 0x4000.D000
 UART2 base: 0x4000.E000
 UART3 base: 0x4000.F000
 UART4 base: 0x4001.0000
 UART5 base: 0x4001.1000
 UART6 base: 0x4001.2000
 UART7 base: 0x4001.3000
 Offset 0x044
 Type W1C, reset 0x0000.0000

	31	30	29	28	27	26	25	24	23	22	21	20	19	18	17	16
	reserved															
Type	RO	RO	RO	RO	RO	RO	RO	RO	RO	RO	RO	RO	RO	RO	RO	RO
Reset	0	0	0	0	0	0	0	0	0	0	0	0	0	0	0	0
	15	14	13	12	11	10	9	8	7	6	5	4	3	2	1	0
	LME5IC	LME1IC	LMSBIC	9BITIC	reserved	OEIC	BEIC	PEIC	FEIC	RTIC	TXIC	RXIC	reserved	CTSMIC	reserved	
Type	W1C	W1C	W1C	R/W	RO	W1C	W1C	W1C	W1C	W1C	W1C	W1C	RO	RO	W1C	RO
Reset	0	0	0	0	0	0	0	0	0	0	0	0	0	0	0	0

Bit/Field	Name	Type	Reset	Description
31:16	reserved	RO	0	Software should not rely on the value of a reserved bit. To provide compatibility with future products, the value of a reserved bit should be preserved across a read-modify-write operation.
15	LME5IC	W1C	0	LIN Mode Edge 5 Interrupt Clear Writing a 1 to this bit clears the LME5RIS bit in the UARTRIS register and the LME5MIS bit in the UARTMIS register.
14	LME1IC	W1C	0	LIN Mode Edge 1 Interrupt Clear Writing a 1 to this bit clears the LME1RIS bit in the UARTRIS register and the LME1MIS bit in the UARTMIS register.
13	LMSBIC	W1C	0	LIN Mode Sync Break Interrupt Clear Writing a 1 to this bit clears the LMSBRIS bit in the UARTRIS register and the LMSBMIS bit in the UARTMIS register.
12	9BITIC	R/W	0	9-Bit Mode Interrupt Clear Writing a 1 to this bit clears the 9BITRIS bit in the UARTRIS register and the 9BITMIS bit in the UARTMIS register.
11	reserved	RO	0	Software should not rely on the value of a reserved bit. To provide compatibility with future products, the value of a reserved bit should be preserved across a read-modify-write operation.
10	OEIC	W1C	0	Overrun Error Interrupt Clear Writing a 1 to this bit clears the OERIS bit in the UARTRIS register and the OEMIS bit in the UARTMIS register.
9	BEIC	W1C	0	Break Error Interrupt Clear Writing a 1 to this bit clears the BERIS bit in the UARTRIS register and the BEMIS bit in the UARTMIS register.

Bit/Field	Name	Type	Reset	Description
8	PEIC	W1C	0	Parity Error Interrupt Clear Writing a 1 to this bit clears the PERIS bit in the UARTRIS register and the PEMIS bit in the UARTMIS register.
7	FEIC	W1C	0	Framing Error Interrupt Clear Writing a 1 to this bit clears the FERIS bit in the UARTRIS register and the FEMIS bit in the UARTMIS register.
6	RTIC	W1C	0	Receive Time-Out Interrupt Clear Writing a 1 to this bit clears the RTRIS bit in the UARTRIS register and the RTMIS bit in the UARTMIS register.
5	TXIC	W1C	0	Transmit Interrupt Clear Writing a 1 to this bit clears the TXRIS bit in the UARTRIS register and the TXMIS bit in the UARTMIS register.
4	RXIC	W1C	0	Receive Interrupt Clear Writing a 1 to this bit clears the RXRIS bit in the UARTRIS register and the RXMIS bit in the UARTMIS register.
3:2	reserved	RO	0	Software should not rely on the value of a reserved bit. To provide compatibility with future products, the value of a reserved bit should be preserved across a read-modify-write operation.
1	CTSMIC	W1C	0	UART Clear to Send Modem Interrupt Clear Writing a 1 to this bit clears the CTSRIS bit in the UARTRIS register and the CTSMIS bit in the UARTMIS register. This bit is implemented only on UART1 and is reserved for UART0 and UART2.
0	reserved	RO	0	Software should not rely on the value of a reserved bit. To provide compatibility with future products, the value of a reserved bit should be preserved across a read-modify-write operation.

Register 14: UART DMA Control (UARTDMACTL), offset 0x048

The **UARTDMACTL** register is the DMA control register.

UART DMA Control (UARTDMACTL)

UART0 base: 0x4000.C000
 UART1 base: 0x4000.D000
 UART2 base: 0x4000.E000
 UART3 base: 0x4000.F000
 UART4 base: 0x4001.0000
 UART5 base: 0x4001.1000
 UART6 base: 0x4001.2000
 UART7 base: 0x4001.3000
 Offset 0x048
 Type R/W, reset 0x0000.0000

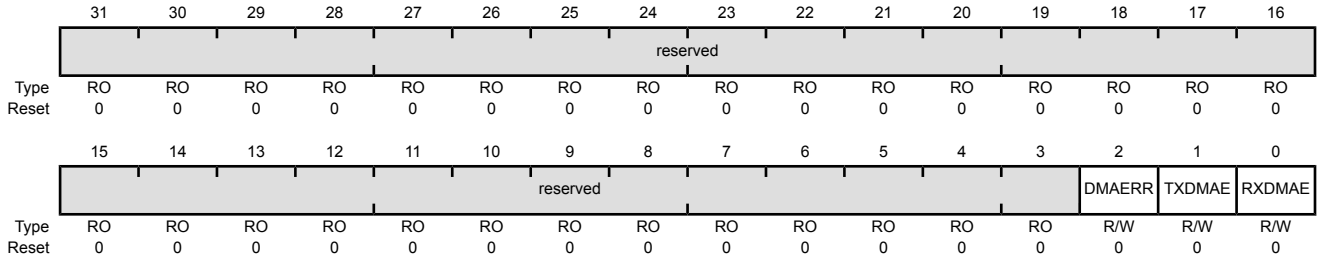

Bit/Field	Name	Type	Reset	Description
31:3	reserved	RO	0x00000.000	Software should not rely on the value of a reserved bit. To provide compatibility with future products, the value of a reserved bit should be preserved across a read-modify-write operation.
2	DMAERR	R/W	0	DMA on Error Value Description 1 μDMA receive requests are automatically disabled when a receive error occurs. 0 μDMA receive requests are unaffected when a receive error occurs.
1	TXDMAE	R/W	0	Transmit DMA Enable Value Description 1 μDMA for the transmit FIFO is enabled. 0 μDMA for the transmit FIFO is disabled.
0	RXDMAE	R/W	0	Receive DMA Enable Value Description 1 μDMA for the receive FIFO is enabled. 0 μDMA for the receive FIFO is disabled.

Register 15: UART LIN Control (UARTLCTL), offset 0x090

The **UARTLCTL** register is the configures the operation of the UART when in LIN mode.

UART LIN Control (UARTLCTL)

UART0 base: 0x4000.C000
 UART1 base: 0x4000.D000
 UART2 base: 0x4000.E000
 UART3 base: 0x4000.F000
 UART4 base: 0x4001.0000
 UART5 base: 0x4001.1000
 UART6 base: 0x4001.2000
 UART7 base: 0x4001.3000
 Offset 0x090
 Type R/W, reset 0x0000.0000

	31	30	29	28	27	26	25	24	23	22	21	20	19	18	17	16
	reserved															
Type	RO	RO	RO	RO	RO	RO	RO	RO	RO	RO	RO	RO	RO	RO	RO	RO
Reset	0	0	0	0	0	0	0	0	0	0	0	0	0	0	0	0
	15	14	13	12	11	10	9	8	7	6	5	4	3	2	1	0
	reserved											BLEN		reserved		MASTER
Type	RO	RO	RO	RO	RO	RO	RO	RO	RO	RO	R/W	R/W	RO	RO	RO	R/W
Reset	0	0	0	0	0	0	0	0	0	0	0	0	0	0	0	0

Bit/Field	Name	Type	Reset	Description
31:6	reserved	RO	0x0000.00	Software should not rely on the value of a reserved bit. To provide compatibility with future products, the value of a reserved bit should be preserved across a read-modify-write operation.
5:4	BLEN	R/W	0x0	Sync Break Length Value Description 0x3 Sync break length is 16T bits 0x2 Sync break length is 15T bits 0x1 Sync break length is 14T bits 0x0 Sync break length is 13T bits (default)
3:1	reserved	RO	0x0	Software should not rely on the value of a reserved bit. To provide compatibility with future products, the value of a reserved bit should be preserved across a read-modify-write operation.
0	MASTER	R/W	0	LIN Master Enable Value Description 1 The UART operates as a LIN master. 0 The UART operates as a LIN slave.

Register 16: UART LIN Snap Shot (UARTLSS), offset 0x094

The **UARTLSS** register captures the free-running timer value when either the Sync Edge 1 or the Sync Edge 5 is detected in LIN mode.

UART LIN Snap Shot (UARTLSS)

UART0 base: 0x4000.C000
 UART1 base: 0x4000.D000
 UART2 base: 0x4000.E000
 UART3 base: 0x4000.F000
 UART4 base: 0x4001.0000
 UART5 base: 0x4001.1000
 UART6 base: 0x4001.2000
 UART7 base: 0x4001.3000
 Offset 0x094
 Type RO, reset 0x0000.0000

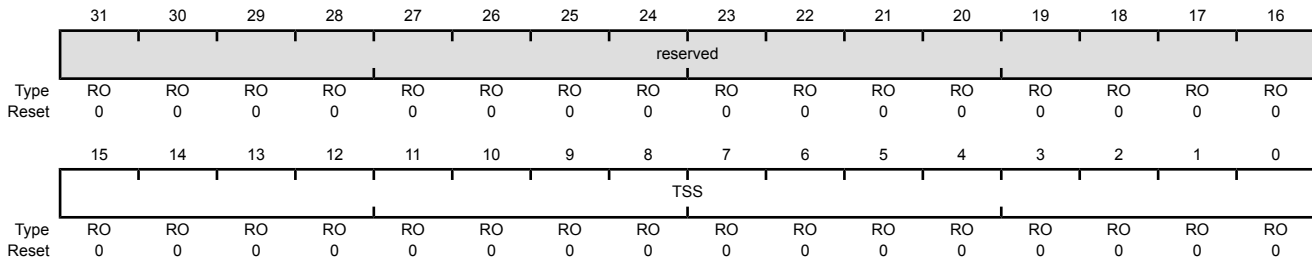

Bit/Field	Name	Type	Reset	Description
31:16	reserved	RO	0x0000	Software should not rely on the value of a reserved bit. To provide compatibility with future products, the value of a reserved bit should be preserved across a read-modify-write operation.
15:0	TSS	RO	0x0000	Timer Snap Shot This field contains the value of the free-running timer when either the Sync Edge 5 or the Sync Edge 1 was detected.

Register 17: UART LIN Timer (UARTLTIM), offset 0x098

The **UARTLTIM** register contains the current timer value for the free-running timer that is used to calculate the baud rate when in LIN slave mode. The value in this register is used along with the value in the **UART LIN Snap Shot (UARTLSS)** register to adjust the baud rate to match that of the master.

Note: If the PIOSC is being used as the UART baud clock (the **CS** field in the **UART Clock Configuration (UARTCC)** register is 0x1), the value in this register should be read twice to ensure the data is correct. If the data does not match, the value should be read again until two consecutive values match. This step is not necessary when using the system clock for the UART baud clock (the **CS** field is 0x0).

UART LIN Timer (UARTLTIM)

UART0 base: 0x4000.C000
 UART1 base: 0x4000.D000
 UART2 base: 0x4000.E000
 UART3 base: 0x4000.F000
 UART4 base: 0x4001.0000
 UART5 base: 0x4001.1000
 UART6 base: 0x4001.2000
 UART7 base: 0x4001.3000
 Offset 0x098
 Type RO, reset 0x0000.0000

	31	30	29	28	27	26	25	24	23	22	21	20	19	18	17	16
	reserved															
Type	RO	RO	RO	RO	RO	RO	RO	RO	RO	RO	RO	RO	RO	RO	RO	RO
Reset	0	0	0	0	0	0	0	0	0	0	0	0	0	0	0	0
	15	14	13	12	11	10	9	8	7	6	5	4	3	2	1	0
	TIMER															
Type	RO	RO	RO	RO	RO	RO	RO	RO	RO	RO	RO	RO	RO	RO	RO	RO
Reset	0	0	0	0	0	0	0	0	0	0	0	0	0	0	0	0

Bit/Field	Name	Type	Reset	Description
31:16	reserved	RO	0x0000	Software should not rely on the value of a reserved bit. To provide compatibility with future products, the value of a reserved bit should be preserved across a read-modify-write operation.
15:0	TIMER	RO	0x0000	Timer Value This field contains the value of the free-running timer.

Register 18: UART 9-Bit Self Address (UART9BITADDR), offset 0x0A4

The **UART9BITADDR** register is used to write the specific address that should be matched with the receiving byte when the 9-bit Address Mask (**UART9BITAMASK**) is set to 0xFF. This register is used in conjunction with **UART9BITAMASK** to form a match for address-byte received.

UART 9-Bit Self Address (UART9BITADDR)

UART0 base: 0x4000.C000
 UART1 base: 0x4000.D000
 UART2 base: 0x4000.E000
 UART3 base: 0x4000.F000
 UART4 base: 0x4001.0000
 UART5 base: 0x4001.1000
 UART6 base: 0x4001.2000
 UART7 base: 0x4001.3000
 Offset 0x0A4
 Type R/W, reset 0x0000.0000

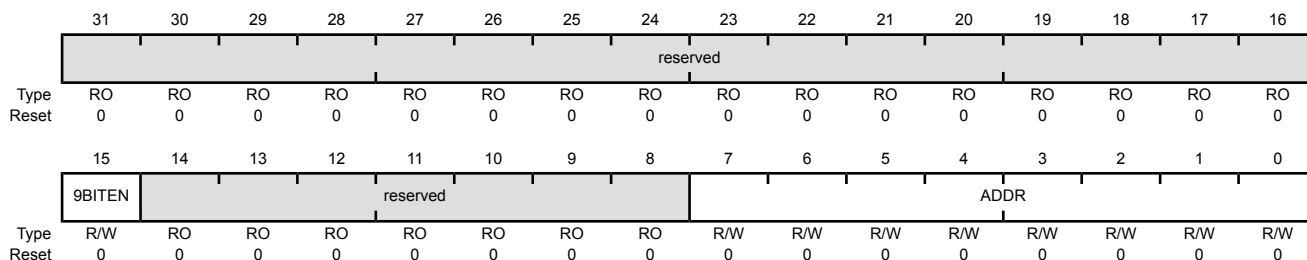

Bit/Field	Name	Type	Reset	Description
31:16	reserved	RO	0x0000	Software should not rely on the value of a reserved bit. To provide compatibility with future products, the value of a reserved bit should be preserved across a read-modify-write operation.
15	9BITEN	R/W	0	Enable 9-Bit Mode Value Description 1 9-bit mode is enabled. 0 9-bit mode is disabled.
14:8	reserved	RO	0x0	Software should not rely on the value of a reserved bit. To provide compatibility with future products, the value of a reserved bit should be preserved across a read-modify-write operation.
7:0	ADDR	R/W	0x00	Self Address for 9-Bit Mode This field contains the address that should be matched when UART9BITAMASK is 0xFF.

Register 19: UART 9-Bit Self Address Mask (UART9BITAMASK), offset 0x0A8

The **UART9BITAMASK** register is used to enable the address mask for 9-bit mode. The address bits are masked to create a set of addresses to be matched with the received address byte.

UART 9-Bit Self Address Mask (UART9BITAMASK)

UART0 base: 0x4000.C000
 UART1 base: 0x4000.D000
 UART2 base: 0x4000.E000
 UART3 base: 0x4000.F000
 UART4 base: 0x4001.0000
 UART5 base: 0x4001.1000
 UART6 base: 0x4001.2000
 UART7 base: 0x4001.3000
 Offset 0x0A8
 Type R/W, reset 0x0000.00FF

	31	30	29	28	27	26	25	24	23	22	21	20	19	18	17	16
	reserved															
Type	RO	RO	RO	RO	RO	RO	RO	RO	RO	RO	RO	RO	RO	RO	RO	RO
Reset	0	0	0	0	0	0	0	0	0	0	0	0	0	0	0	0
	15	14	13	12	11	10	9	8	7	6	5	4	3	2	1	0
	reserved								MASK							
Type	RO	RO	RO	RO	RO	RO	RO	RO	R/W	R/W	R/W	R/W	R/W	R/W	R/W	R/W
Reset	0	0	0	0	0	0	0	0	1	1	1	1	1	1	1	1

Bit/Field	Name	Type	Reset	Description
31:8	reserved	RO	0x00	Software should not rely on the value of a reserved bit. To provide compatibility with future products, the value of a reserved bit should be preserved across a read-modify-write operation.
7:0	MASK	R/W	0xFF	Self Address Mask for 9-Bit Mode This field contains the address mask that creates a set of addresses that should be matched.

Register 20: UART Peripheral Properties (UARTPP), offset 0xFC0

The **UARTPP** register provides information regarding the properties of the UART module.

UART Peripheral Properties (UARTPP)

UART0 base: 0x4000.C000
 UART1 base: 0x4000.D000
 UART2 base: 0x4000.E000
 UART3 base: 0x4000.F000
 UART4 base: 0x4001.0000
 UART5 base: 0x4001.1000
 UART6 base: 0x4001.2000
 UART7 base: 0x4001.3000
 Offset 0xFC0
 Type RO, reset 0x0000.0003

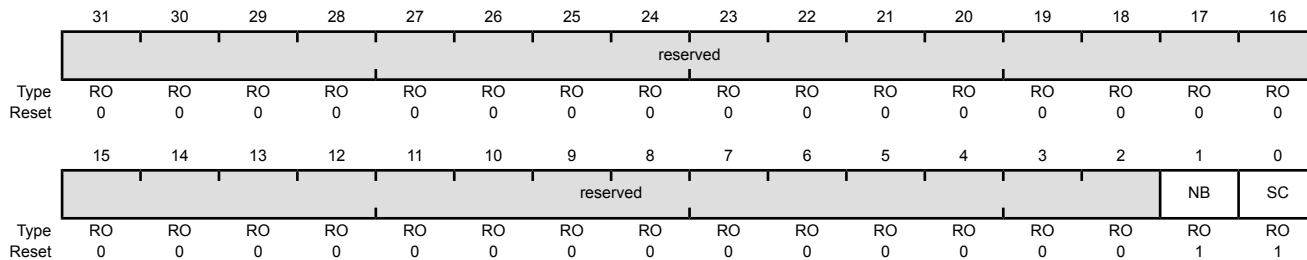

Bit/Field	Name	Type	Reset	Description
31:2	reserved	RO	0x0000.000	Software should not rely on the value of a reserved bit. To provide compatibility with future products, the value of a reserved bit should be preserved across a read-modify-write operation.
1	NB	RO	0x1	9-Bit Support Value Description 1 The UART module provides support for the transmission of 9-bit data for RS-485 support. 0 The UART module does not provide support for the transmission of 9-bit data for RS-485 support.
0	SC	RO	0x1	Smart Card Support Value Description 1 The UART module provides smart card support. 0 The UART module does not provide smart card support.

Register 21: UART Clock Configuration (UARTCC), offset 0xFC8

The **UARTCC** register controls the baud clock source for the UART module. For more information, see the section called “Communication Clock Sources” on page 222.

Note: If the PIOSC is used for the UART baud clock, the system clock frequency must be at least 9 MHz in Run mode.

UART Clock Configuration (UARTCC)

UART0 base: 0x4000.C000
 UART1 base: 0x4000.D000
 UART2 base: 0x4000.E000
 UART3 base: 0x4000.F000
 UART4 base: 0x4001.0000
 UART5 base: 0x4001.1000
 UART6 base: 0x4001.2000
 UART7 base: 0x4001.3000
 Offset 0xFC8
 Type R/W, reset 0x0000.0000

	31	30	29	28	27	26	25	24	23	22	21	20	19	18	17	16
	reserved															
Type	RO	RO	RO	RO	RO	RO	RO	RO	RO	RO	RO	RO	RO	RO	RO	RO
Reset	0	0	0	0	0	0	0	0	0	0	0	0	0	0	0	0
	15	14	13	12	11	10	9	8	7	6	5	4	3	2	1	0
	reserved												CS			
Type	RO	RO	RO	RO	RO	RO	RO	RO	RO	RO	RO	RO	R/W	R/W	R/W	R/W
Reset	0	0	0	0	0	0	0	0	0	0	0	0	0	0	0	0

Bit/Field	Name	Type	Reset	Description
31:4	reserved	RO	0x0000.000	Software should not rely on the value of a reserved bit. To provide compatibility with future products, the value of a reserved bit should be preserved across a read-modify-write operation.
3:0	CS	R/W	0	UART Baud Clock Source The following table specifies the source that generates for the UART baud clock:
	Value	Description		
	0x0	System clock (based on clock source and divisor factor)		
	0x1-0x4	reserved		
	0x5	PIOSC		
	0x5-0xF	Reserved		

Register 22: UART Peripheral Identification 4 (UARTPeriphID4), offset 0xFD0

The **UARTPeriphIDn** registers are hard-coded and the fields within the registers determine the reset values.

UART Peripheral Identification 4 (UARTPeriphID4)

UART0 base: 0x4000.C000
 UART1 base: 0x4000.D000
 UART2 base: 0x4000.E000
 UART3 base: 0x4000.F000
 UART4 base: 0x4001.0000
 UART5 base: 0x4001.1000
 UART6 base: 0x4001.2000
 UART7 base: 0x4001.3000
 Offset 0xFD0
 Type RO, reset 0x0000.0000

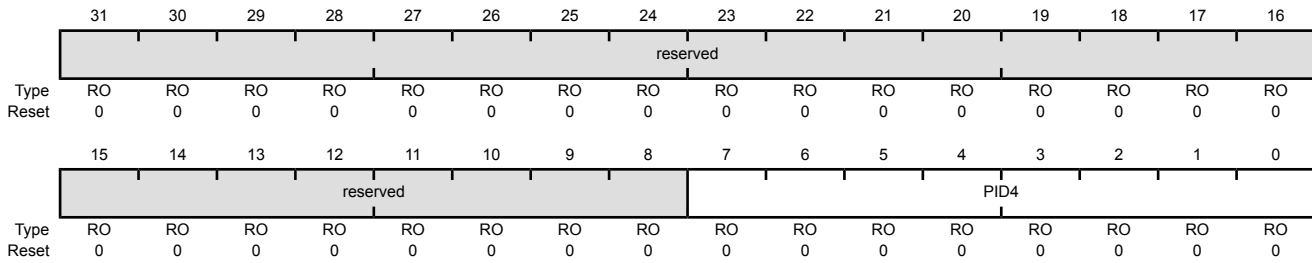

Bit/Field	Name	Type	Reset	Description
31:8	reserved	RO	0x0000.00	Software should not rely on the value of a reserved bit. To provide compatibility with future products, the value of a reserved bit should be preserved across a read-modify-write operation.
7:0	PID4	RO	0x00	UART Peripheral ID Register [7:0] Can be used by software to identify the presence of this peripheral.

Register 23: UART Peripheral Identification 5 (UARTPeriphID5), offset 0xFD4

The **UARTPeriphIDn** registers are hard-coded and the fields within the registers determine the reset values.

UART Peripheral Identification 5 (UARTPeriphID5)

UART0 base: 0x4000.C000
 UART1 base: 0x4000.D000
 UART2 base: 0x4000.E000
 UART3 base: 0x4000.F000
 UART4 base: 0x4001.0000
 UART5 base: 0x4001.1000
 UART6 base: 0x4001.2000
 UART7 base: 0x4001.3000
 Offset 0xFD4
 Type RO, reset 0x0000.0000

	31	30	29	28	27	26	25	24	23	22	21	20	19	18	17	16
	reserved															
Type	RO	RO	RO	RO	RO	RO	RO	RO	RO	RO	RO	RO	RO	RO	RO	RO
Reset	0	0	0	0	0	0	0	0	0	0	0	0	0	0	0	0
	15	14	13	12	11	10	9	8	7	6	5	4	3	2	1	0
	reserved								PID5							
Type	RO	RO	RO	RO	RO	RO	RO	RO	RO	RO	RO	RO	RO	RO	RO	RO
Reset	0	0	0	0	0	0	0	0	0	0	0	0	0	0	0	0

Bit/Field	Name	Type	Reset	Description
31:8	reserved	RO	0x0000.00	Software should not rely on the value of a reserved bit. To provide compatibility with future products, the value of a reserved bit should be preserved across a read-modify-write operation.
7:0	PID5	RO	0x00	UART Peripheral ID Register [15:8] Can be used by software to identify the presence of this peripheral.

Register 24: UART Peripheral Identification 6 (UARTPeriphID6), offset 0xFD8

The **UARTPeriphIDn** registers are hard-coded and the fields within the registers determine the reset values.

UART Peripheral Identification 6 (UARTPeriphID6)

UART0 base: 0x4000.C000
 UART1 base: 0x4000.D000
 UART2 base: 0x4000.E000
 UART3 base: 0x4000.F000
 UART4 base: 0x4001.0000
 UART5 base: 0x4001.1000
 UART6 base: 0x4001.2000
 UART7 base: 0x4001.3000
 Offset 0xFD8
 Type RO, reset 0x0000.0000

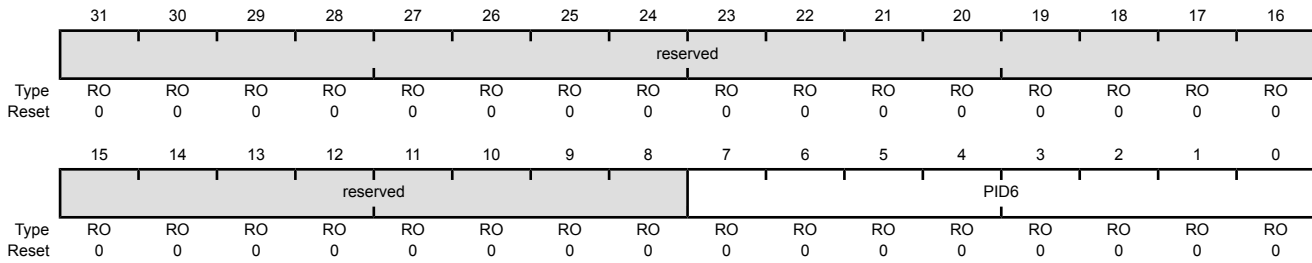

Bit/Field	Name	Type	Reset	Description
31:8	reserved	RO	0x0000.00	Software should not rely on the value of a reserved bit. To provide compatibility with future products, the value of a reserved bit should be preserved across a read-modify-write operation.
7:0	PID6	RO	0x00	UART Peripheral ID Register [23:16] Can be used by software to identify the presence of this peripheral.

Register 25: UART Peripheral Identification 7 (UARTPeriphID7), offset 0xFDC

The **UARTPeriphIDn** registers are hard-coded and the fields within the registers determine the reset values.

UART Peripheral Identification 7 (UARTPeriphID7)

UART0 base: 0x4000.C000
 UART1 base: 0x4000.D000
 UART2 base: 0x4000.E000
 UART3 base: 0x4000.F000
 UART4 base: 0x4001.0000
 UART5 base: 0x4001.1000
 UART6 base: 0x4001.2000
 UART7 base: 0x4001.3000
 Offset 0xFDC
 Type RO, reset 0x0000.0000

	31	30	29	28	27	26	25	24	23	22	21	20	19	18	17	16
	reserved															
Type	RO	RO	RO	RO	RO	RO	RO	RO	RO	RO	RO	RO	RO	RO	RO	RO
Reset	0	0	0	0	0	0	0	0	0	0	0	0	0	0	0	0
	15	14	13	12	11	10	9	8	7	6	5	4	3	2	1	0
	reserved								PID7							
Type	RO	RO	RO	RO	RO	RO	RO	RO	RO	RO	RO	RO	RO	RO	RO	RO
Reset	0	0	0	0	0	0	0	0	0	0	0	0	0	0	0	0

Bit/Field	Name	Type	Reset	Description
31:8	reserved	RO	0x0000.00	Software should not rely on the value of a reserved bit. To provide compatibility with future products, the value of a reserved bit should be preserved across a read-modify-write operation.
7:0	PID7	RO	0x00	UART Peripheral ID Register [31:24] Can be used by software to identify the presence of this peripheral.

Register 26: UART Peripheral Identification 0 (UARTPeriphID0), offset 0xFE0

The **UARTPeriphIDn** registers are hard-coded and the fields within the registers determine the reset values.

UART Peripheral Identification 0 (UARTPeriphID0)

UART0 base: 0x4000.C000
 UART1 base: 0x4000.D000
 UART2 base: 0x4000.E000
 UART3 base: 0x4000.F000
 UART4 base: 0x4001.0000
 UART5 base: 0x4001.1000
 UART6 base: 0x4001.2000
 UART7 base: 0x4001.3000
 Offset 0xFE0
 Type RO, reset 0x0000.0060

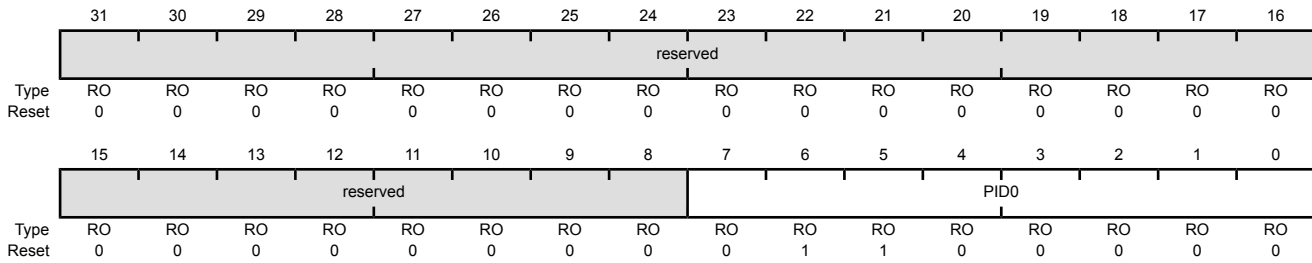

Bit/Field	Name	Type	Reset	Description
31:8	reserved	RO	0x0000.00	Software should not rely on the value of a reserved bit. To provide compatibility with future products, the value of a reserved bit should be preserved across a read-modify-write operation.
7:0	PID0	RO	0x60	UART Peripheral ID Register [7:0] Can be used by software to identify the presence of this peripheral.

Register 27: UART Peripheral Identification 1 (UARTPeriphID1), offset 0xFE4

The **UARTPeriphIDn** registers are hard-coded and the fields within the registers determine the reset values.

UART Peripheral Identification 1 (UARTPeriphID1)

UART0 base: 0x4000.C000
 UART1 base: 0x4000.D000
 UART2 base: 0x4000.E000
 UART3 base: 0x4000.F000
 UART4 base: 0x4001.0000
 UART5 base: 0x4001.1000
 UART6 base: 0x4001.2000
 UART7 base: 0x4001.3000
 Offset 0xFE4
 Type RO, reset 0x0000.0000

	31	30	29	28	27	26	25	24	23	22	21	20	19	18	17	16
	reserved															
Type	RO	RO	RO	RO	RO	RO	RO	RO	RO	RO	RO	RO	RO	RO	RO	RO
Reset	0	0	0	0	0	0	0	0	0	0	0	0	0	0	0	0
	15	14	13	12	11	10	9	8	7	6	5	4	3	2	1	0
	reserved								PID1							
Type	RO	RO	RO	RO	RO	RO	RO	RO	RO	RO	RO	RO	RO	RO	RO	RO
Reset	0	0	0	0	0	0	0	0	0	0	0	0	0	0	0	0

Bit/Field	Name	Type	Reset	Description
31:8	reserved	RO	0x0000.00	Software should not rely on the value of a reserved bit. To provide compatibility with future products, the value of a reserved bit should be preserved across a read-modify-write operation.
7:0	PID1	RO	0x00	UART Peripheral ID Register [15:8] Can be used by software to identify the presence of this peripheral.

Register 28: UART Peripheral Identification 2 (UARTPeriphID2), offset 0xFE8

The **UARTPeriphIDn** registers are hard-coded and the fields within the registers determine the reset values.

UART Peripheral Identification 2 (UARTPeriphID2)

UART0 base: 0x4000.C000
 UART1 base: 0x4000.D000
 UART2 base: 0x4000.E000
 UART3 base: 0x4000.F000
 UART4 base: 0x4001.0000
 UART5 base: 0x4001.1000
 UART6 base: 0x4001.2000
 UART7 base: 0x4001.3000
 Offset 0xFE8
 Type RO, reset 0x0000.0018

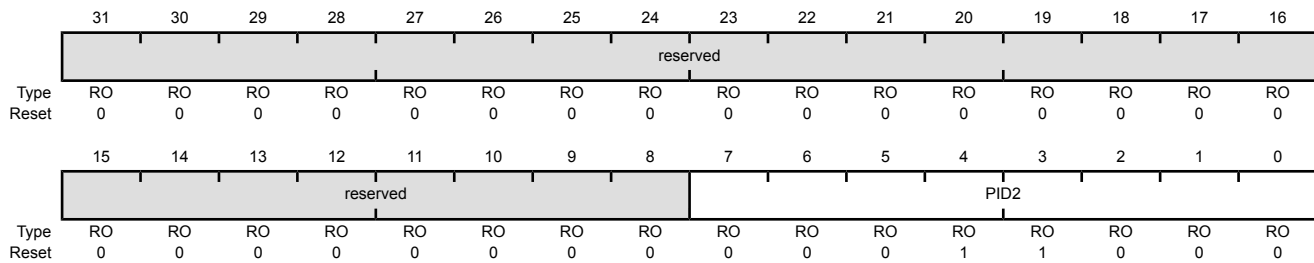

Bit/Field	Name	Type	Reset	Description
31:8	reserved	RO	0x0000.00	Software should not rely on the value of a reserved bit. To provide compatibility with future products, the value of a reserved bit should be preserved across a read-modify-write operation.
7:0	PID2	RO	0x18	UART Peripheral ID Register [23:16] Can be used by software to identify the presence of this peripheral.

Register 29: UART Peripheral Identification 3 (UARTPeriphID3), offset 0xFEC

The **UARTPeriphIDn** registers are hard-coded and the fields within the registers determine the reset values.

UART Peripheral Identification 3 (UARTPeriphID3)

UART0 base: 0x4000.C000
 UART1 base: 0x4000.D000
 UART2 base: 0x4000.E000
 UART3 base: 0x4000.F000
 UART4 base: 0x4001.0000
 UART5 base: 0x4001.1000
 UART6 base: 0x4001.2000
 UART7 base: 0x4001.3000
 Offset 0xFEC
 Type RO, reset 0x0000.0001

	31	30	29	28	27	26	25	24	23	22	21	20	19	18	17	16
	reserved															
Type	RO	RO	RO	RO	RO	RO	RO	RO	RO	RO	RO	RO	RO	RO	RO	RO
Reset	0	0	0	0	0	0	0	0	0	0	0	0	0	0	0	0
	15	14	13	12	11	10	9	8	7	6	5	4	3	2	1	0
	reserved								PID3							
Type	RO	RO	RO	RO	RO	RO	RO	RO	RO	RO	RO	RO	RO	RO	RO	RO
Reset	0	0	0	0	0	0	0	0	0	0	0	0	0	0	0	1

Bit/Field	Name	Type	Reset	Description
31:8	reserved	RO	0x0000.00	Software should not rely on the value of a reserved bit. To provide compatibility with future products, the value of a reserved bit should be preserved across a read-modify-write operation.
7:0	PID3	RO	0x01	UART Peripheral ID Register [31:24] Can be used by software to identify the presence of this peripheral.

Register 30: UART PrimeCell Identification 0 (UARTPCellID0), offset 0xFF0

The **UARTPCellIDn** registers are hard-coded and the fields within the registers determine the reset values.

UART PrimeCell Identification 0 (UARTPCellID0)

UART0 base: 0x4000.C000
 UART1 base: 0x4000.D000
 UART2 base: 0x4000.E000
 UART3 base: 0x4000.F000
 UART4 base: 0x4001.0000
 UART5 base: 0x4001.1000
 UART6 base: 0x4001.2000
 UART7 base: 0x4001.3000
 Offset 0xFF0
 Type RO, reset 0x0000.000D

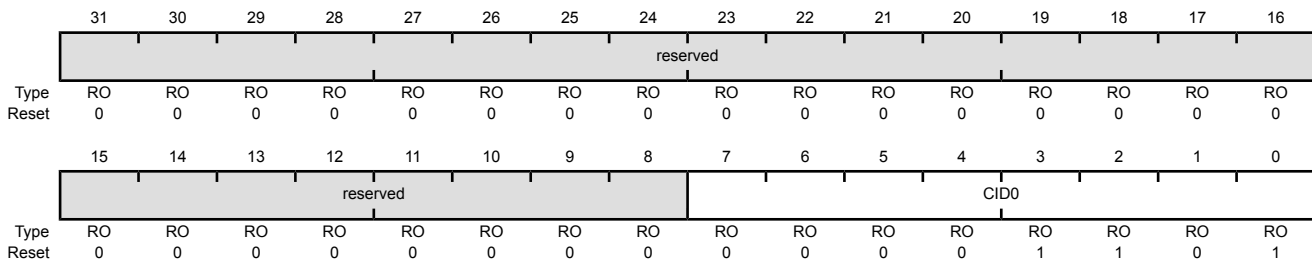

Bit/Field	Name	Type	Reset	Description
31:8	reserved	RO	0x0000.00	Software should not rely on the value of a reserved bit. To provide compatibility with future products, the value of a reserved bit should be preserved across a read-modify-write operation.
7:0	CID0	RO	0x0D	UART PrimeCell ID Register [7:0] Provides software a standard cross-peripheral identification system.

Register 31: UART PrimeCell Identification 1 (UARTPCelIID1), offset 0xFF4

The **UARTPCelIIDn** registers are hard-coded and the fields within the registers determine the reset values.

UART PrimeCell Identification 1 (UARTPCelIID1)

UART0 base: 0x4000.C000
 UART1 base: 0x4000.D000
 UART2 base: 0x4000.E000
 UART3 base: 0x4000.F000
 UART4 base: 0x4001.0000
 UART5 base: 0x4001.1000
 UART6 base: 0x4001.2000
 UART7 base: 0x4001.3000
 Offset 0xFF4
 Type RO, reset 0x0000.00F0

	31	30	29	28	27	26	25	24	23	22	21	20	19	18	17	16
	reserved															
Type	RO	RO	RO	RO	RO	RO	RO	RO	RO	RO	RO	RO	RO	RO	RO	RO
Reset	0	0	0	0	0	0	0	0	0	0	0	0	0	0	0	0
	15	14	13	12	11	10	9	8	7	6	5	4	3	2	1	0
	reserved								CID1							
Type	RO	RO	RO	RO	RO	RO	RO	RO	RO	RO	RO	RO	RO	RO	RO	RO
Reset	0	0	0	0	0	0	0	0	1	1	1	1	0	0	0	0

Bit/Field	Name	Type	Reset	Description
31:8	reserved	RO	0x0000.00	Software should not rely on the value of a reserved bit. To provide compatibility with future products, the value of a reserved bit should be preserved across a read-modify-write operation.
7:0	CID1	RO	0xF0	UART PrimeCell ID Register [15:8] Provides software a standard cross-peripheral identification system.

Register 32: UART PrimeCell Identification 2 (UARTPCellID2), offset 0xFF8

The **UARTPCellIDn** registers are hard-coded and the fields within the registers determine the reset values.

UART PrimeCell Identification 2 (UARTPCellID2)

UART0 base: 0x4000.C000
 UART1 base: 0x4000.D000
 UART2 base: 0x4000.E000
 UART3 base: 0x4000.F000
 UART4 base: 0x4001.0000
 UART5 base: 0x4001.1000
 UART6 base: 0x4001.2000
 UART7 base: 0x4001.3000
 Offset 0xFF8
 Type RO, reset 0x0000.0005

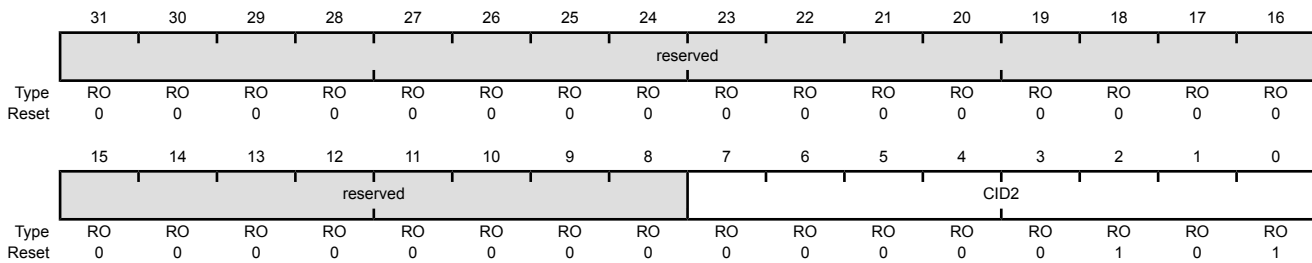

Bit/Field	Name	Type	Reset	Description
31:8	reserved	RO	0x0000.00	Software should not rely on the value of a reserved bit. To provide compatibility with future products, the value of a reserved bit should be preserved across a read-modify-write operation.
7:0	CID2	RO	0x05	UART PrimeCell ID Register [23:16] Provides software a standard cross-peripheral identification system.

Register 33: UART PrimeCell Identification 3 (UARTPCelIID3), offset 0xFFC

The **UARTPCelIIDn** registers are hard-coded and the fields within the registers determine the reset values.

UART PrimeCell Identification 3 (UARTPCelIID3)

UART0 base: 0x4000.C000
 UART1 base: 0x4000.D000
 UART2 base: 0x4000.E000
 UART3 base: 0x4000.F000
 UART4 base: 0x4001.0000
 UART5 base: 0x4001.1000
 UART6 base: 0x4001.2000
 UART7 base: 0x4001.3000
 Offset 0xFFC
 Type RO, reset 0x0000.00B1

	31	30	29	28	27	26	25	24	23	22	21	20	19	18	17	16
	reserved															
Type	RO	RO	RO	RO	RO	RO	RO	RO	RO	RO	RO	RO	RO	RO	RO	RO
Reset	0	0	0	0	0	0	0	0	0	0	0	0	0	0	0	0
	15	14	13	12	11	10	9	8	7	6	5	4	3	2	1	0
	reserved								CID3							
Type	RO	RO	RO	RO	RO	RO	RO	RO	RO	RO	RO	RO	RO	RO	RO	RO
Reset	0	0	0	0	0	0	0	0	1	0	1	1	0	0	0	1

Bit/Field	Name	Type	Reset	Description
31:8	reserved	RO	0x0000.00	Software should not rely on the value of a reserved bit. To provide compatibility with future products, the value of a reserved bit should be preserved across a read-modify-write operation.
7:0	CID3	RO	0xB1	UART PrimeCell ID Register [31:24] Provides software a standard cross-peripheral identification system.

14 Synchronous Serial Interface (SSI)

The Stellaris[®] microcontroller includes four Synchronous Serial Interface (SSI) modules. Each SSI module is a master or slave interface for synchronous serial communication with peripheral devices that have either Freescale SPI, MICROWIRE, or Texas Instruments synchronous serial interfaces.

The Stellaris LM4F231H5QR controller includes four SSI modules with the following features:

- Programmable interface operation for Freescale SPI, MICROWIRE, or Texas Instruments synchronous serial interfaces
- Master or slave operation
- Programmable clock bit rate and prescaler
- Separate transmit and receive FIFOs, each 16 bits wide and 8 locations deep
- Programmable data frame size from 4 to 16 bits
- Internal loopback test mode for diagnostic/debug testing
- Standard FIFO-based interrupts and End-of-Transmission interrupt
- Efficient transfers using Micro Direct Memory Access Controller (μ DMA)
 - Separate channels for transmit and receive
 - Receive single request asserted when data is in the FIFO; burst request asserted when FIFO contains 4 entries
 - Transmit single request asserted when there is space in the FIFO; burst request asserted when FIFO contains 4 entries

14.1 Block Diagram

Figure 14-1. SSI Module Block Diagram

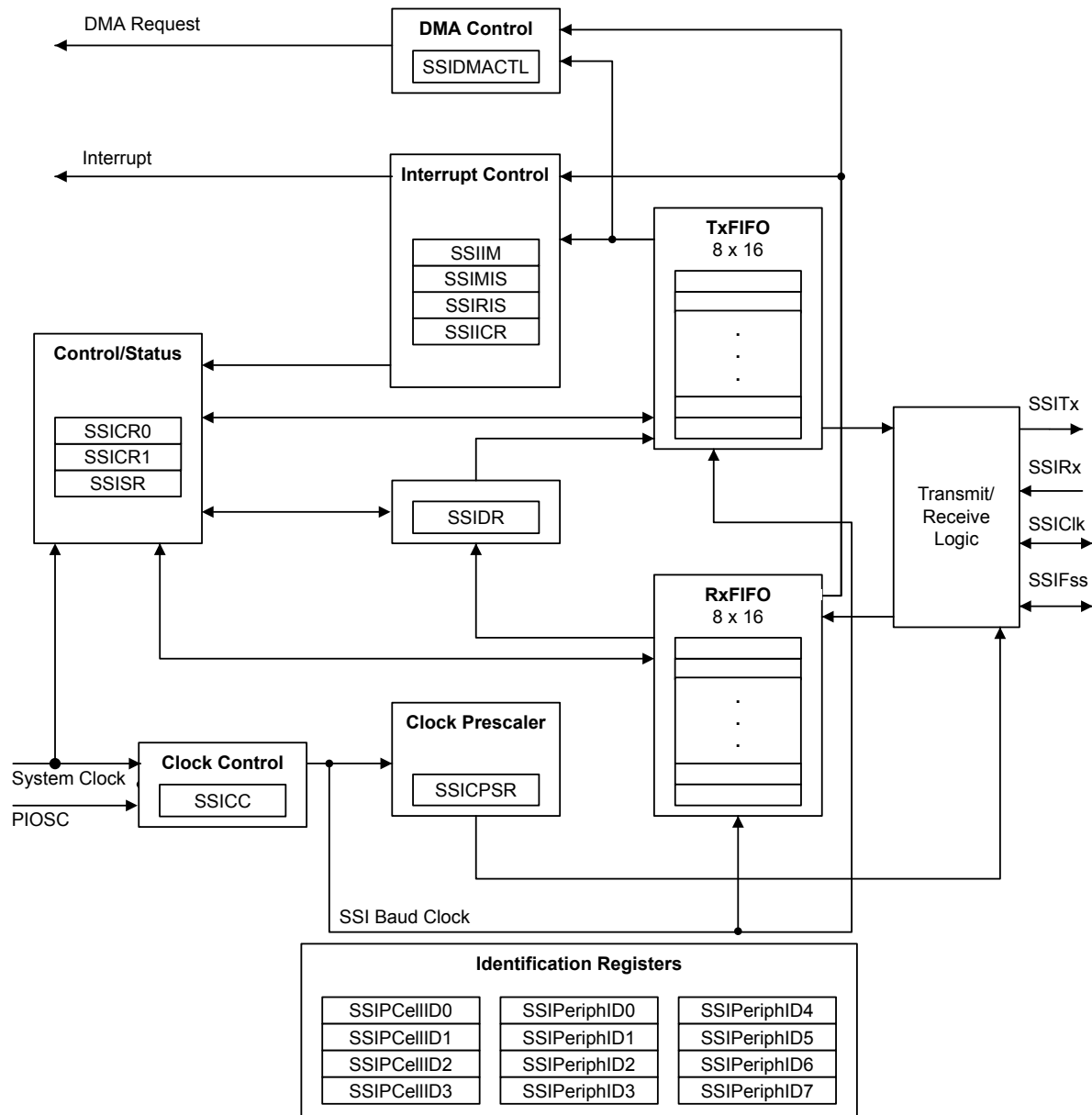

14.2 Signal Description

The following table lists the external signals of the SSI module and describes the function of each. Most SSI signals are alternate functions for some GPIO signals and default to be GPIO signals at reset. The exceptions to this rule are the `SSI0Clk`, `SSI0Fss`, `SSI0Rx`, and `SSI0Tx` pins, which default to the SSI function. The "Pin Mux/Pin Assignment" column in the following table lists the possible GPIO pin placements for the SSI signals. The `AFSEL` bit in the **GPIO Alternate Function Select (GPIOAFSEL)** register (page 644) should be set to choose the SSI function. The number in parentheses is the encoding that must be programmed into the `PMCn` field in the **GPIO Port Control**

(**GPIOCTL**) register (page 661) to assign the SSI signal to the specified GPIO port pin. For more information on configuring GPIOs, see “General-Purpose Input/Outputs (GPIOs)” on page 623.

Table 14-1. SSI Signals (64LQFP)

Pin Name	Pin Number	Pin Mux / Pin Assignment	Pin Type	Buffer Type ^a	Description
SSI0Clk	19	PA2 (2)	I/O	TTL	SSI module 0 clock
SSI0Fss	20	PA3 (2)	I/O	TTL	SSI module 0 frame signal
SSI0Rx	21	PA4 (2)	I	TTL	SSI module 0 receive
SSI0Tx	22	PA5 (2)	O	TTL	SSI module 0 transmit
SSI1Clk	30 61	PF2 (2) PD0 (2)	I/O	TTL	SSI module 1 clock
SSI1Fss	31 62	PF3 (2) PD1 (2)	I/O	TTL	SSI module 1 frame signal
SSI1Rx	28 63	PF0 (2) PD2 (2)	I	TTL	SSI module 1 receive
SSI1Tx	29 64	PF1 (2) PD3 (2)	O	TTL	SSI module 1 transmit
SSI2Clk	58	PB4 (2)	I/O	TTL	SSI module 2 clock
SSI2Fss	57	PB5 (2)	I/O	TTL	SSI module 2 frame signal
SSI2Rx	1	PB6 (2)	I	TTL	SSI module 2 receive
SSI2Tx	4	PB7 (2)	O	TTL	SSI module 2 transmit
SSI3Clk	61	PD0 (1)	I/O	TTL	SSI module 3 clock
SSI3Fss	62	PD1 (1)	I/O	TTL	SSI module 3 frame signal
SSI3Rx	63	PD2 (1)	I	TTL	SSI module 3 receive
SSI3Tx	64	PD3 (1)	O	TTL	SSI module 3 transmit

a. The TTL designation indicates the pin has TTL-compatible voltage levels.

14.3 Functional Description

The SSI performs serial-to-parallel conversion on data received from a peripheral device. The CPU accesses data, control, and status information. The transmit and receive paths are buffered with internal FIFO memories allowing up to eight 16-bit values to be stored independently in both transmit and receive modes. The SSI also supports the μ DMA interface. The transmit and receive FIFOs can be programmed as destination/source addresses in the μ DMA module. μ DMA operation is enabled by setting the appropriate bit(s) in the **SSIDMACTL** register (see page 947).

14.3.1 Bit Rate Generation

The SSI includes a programmable bit rate clock divider and prescaler to generate the serial output clock. Bit rates are supported to 2 MHz and higher, although maximum bit rate is determined by peripheral devices.

The serial bit rate is derived by dividing down the input clock (SysClk). The clock is first divided by an even prescale value **CPSDVSR** from 2 to 254, which is programmed in the **SSI Clock Prescale (SSICPSR)** register (see page 940). The clock is further divided by a value from 1 to 256, which is $1 + \text{SCR}$, where **SCR** is the value programmed in the **SSI Control 0 (SSICR0)** register (see page 933).

The frequency of the output clock **SSIClk** is defined by:

$$\text{SSIClk} = \text{SysClk} / (\text{CPSDVSR} * (1 + \text{SCR}))$$

Note: The PIOSC is used as the source for the `SSIClk` when the `CS` field in the **SSI Clock Configuration (SSICC)** register is configured to 0x1. For master mode, the system clock or the PIOSC must be at least two times faster than the `SSIClk`, with the restriction that `SSIClk` cannot be faster than 25 MHz. For slave mode, the system clock or the PIOSC must be at least 6 times faster than the `SSIClk`.

See “Synchronous Serial Interface (SSI)” on page 1337 to view SSI timing parameters.

14.3.2 FIFO Operation

14.3.2.1 Transmit FIFO

The common transmit FIFO is a 16-bit wide, 8-locations deep, first-in, first-out memory buffer. The CPU writes data to the FIFO by writing the **SSI Data (SSIDR)** register (see page 937), and data is stored in the FIFO until it is read out by the transmission logic.

When configured as a master or a slave, parallel data is written into the transmit FIFO prior to serial conversion and transmission to the attached slave or master, respectively, through the `SSITx` pin.

In slave mode, the SSI transmits data each time the master initiates a transaction. If the transmit FIFO is empty and the master initiates, the slave transmits the 8th most recent value in the transmit FIFO. If less than 8 values have been written to the transmit FIFO since the SSI module clock was enabled using the `Rn` bit in the **RCGSSI** register, then 0 is transmitted. Care should be taken to ensure that valid data is in the FIFO as needed. The SSI can be configured to generate an interrupt or a μ DMA request when the FIFO is empty.

14.3.2.2 Receive FIFO

The common receive FIFO is a 16-bit wide, 8-locations deep, first-in, first-out memory buffer. Received data from the serial interface is stored in the buffer until read out by the CPU, which accesses the read FIFO by reading the **SSIDR** register.

When configured as a master or slave, serial data received through the `SSIRx` pin is registered prior to parallel loading into the attached slave or master receive FIFO, respectively.

14.3.3 Interrupts

The SSI can generate interrupts when the following conditions are observed:

- Transmit FIFO service (when the transmit FIFO is half full or less)
- Receive FIFO service (when the receive FIFO is half full or more)
- Receive FIFO time-out
- Receive FIFO overrun
- End of transmission

All of the interrupt events are ORed together before being sent to the interrupt controller, so the SSI generates a single interrupt request to the controller regardless of the number of active interrupts. Each of the four individual maskable interrupts can be masked by clearing the appropriate bit in the **SSI Interrupt Mask (SSIIM)** register (see page 941). Setting the appropriate mask bit enables the interrupt.

The individual outputs, along with a combined interrupt output, allow use of either a global interrupt service routine or modular device drivers to handle interrupts. The transmit and receive dynamic

dataflow interrupts have been separated from the status interrupts so that data can be read or written in response to the FIFO trigger levels. The status of the individual interrupt sources can be read from the **SSI Raw Interrupt Status (SSIRIS)** and **SSI Masked Interrupt Status (SSIMIS)** registers (see page 942 and page 944, respectively).

The receive FIFO has a time-out period that is 32 periods at the rate of $SSIClk$ (whether or not $SSIClk$ is currently active) and is started when the RX FIFO goes from EMPTY to not-EMPTY. If the RX FIFO is emptied before 32 clocks have passed, the time-out period is reset. As a result, the ISR should clear the Receive FIFO Time-out Interrupt just after reading out the RX FIFO by writing a 1 to the $RTIC$ bit in the **SSI Interrupt Clear (SSIICR)** register. The interrupt should not be cleared so late that the ISR returns before the interrupt is actually cleared, or the ISR may be re-activated unnecessarily.

The End-of-Transmission (EOT) interrupt indicates that the data has been transmitted completely. This interrupt can be used to indicate when it is safe to turn off the SSI module clock or enter sleep mode. In addition, because transmitted data and received data complete at exactly the same time, the interrupt can also indicate that read data is ready immediately, without waiting for the receive FIFO time-out period to complete.

14.3.4 Frame Formats

Each data frame is between 4 and 16 bits long depending on the size of data programmed and is transmitted starting with the MSB. There are three basic frame types that can be selected by programming the FRF bit in the **SSICR0** register:

- Texas Instruments synchronous serial
- Freescale SPI
- MICROWIRE

For all three formats, the serial clock ($SSIClk$) is held inactive while the SSI is idle, and $SSIClk$ transitions at the programmed frequency only during active transmission or reception of data. The idle state of $SSIClk$ is utilized to provide a receive timeout indication that occurs when the receive FIFO still contains data after a timeout period.

For Freescale SPI and MICROWIRE frame formats, the serial frame ($SSIFSS$) pin is active Low, and is asserted (pulled down) during the entire transmission of the frame.

For Texas Instruments synchronous serial frame format, the $SSIFSS$ pin is pulsed for one serial clock period starting at its rising edge, prior to the transmission of each frame. For this frame format, both the SSI and the off-chip slave device drive their output data on the rising edge of $SSIClk$ and latch data from the other device on the falling edge.

Unlike the full-duplex transmission of the other two frame formats, the MICROWIRE format uses a special master-slave messaging technique which operates at half-duplex. In this mode, when a frame begins, an 8-bit control message is transmitted to the off-chip slave. During this transmit, no incoming data is received by the SSI. After the message has been sent, the off-chip slave decodes it and, after waiting one serial clock after the last bit of the 8-bit control message has been sent, responds with the requested data. The returned data can be 4 to 16 bits in length, making the total frame length anywhere from 13 to 25 bits.

14.3.4.1 Texas Instruments Synchronous Serial Frame Format

Figure 14-2 on page 923 shows the Texas Instruments synchronous serial frame format for a single transmitted frame.

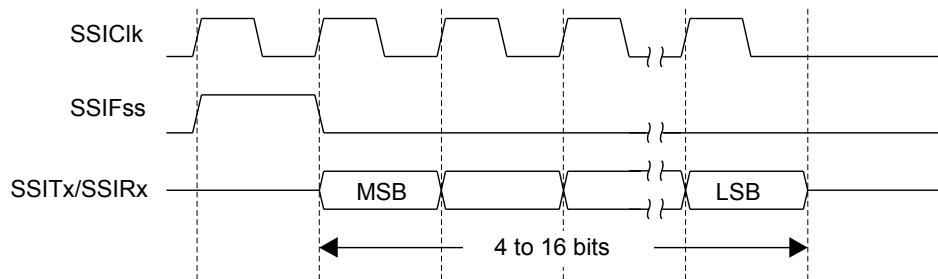
Figure 14-2. TI Synchronous Serial Frame Format (Single Transfer)

In this mode, $SSIClk$ and $SSIFss$ are forced Low, and the transmit data line $SSITx$ is tristated whenever the SSI is idle. Once the bottom entry of the transmit FIFO contains data, $SSIFss$ is pulsed High for one $SSIClk$ period. The value to be transmitted is also transferred from the transmit FIFO to the serial shift register of the transmit logic. On the next rising edge of $SSIClk$, the MSB of the 4 to 16-bit data frame is shifted out on the $SSITx$ pin. Likewise, the MSB of the received data is shifted onto the $SSIRx$ pin by the off-chip serial slave device.

Both the SSI and the off-chip serial slave device then clock each data bit into their serial shifter on each falling edge of $SSIClk$. The received data is transferred from the serial shifter to the receive FIFO on the first rising edge of $SSIClk$ after the LSB has been latched.

Figure 14-3 on page 923 shows the Texas Instruments synchronous serial frame format when back-to-back frames are transmitted.

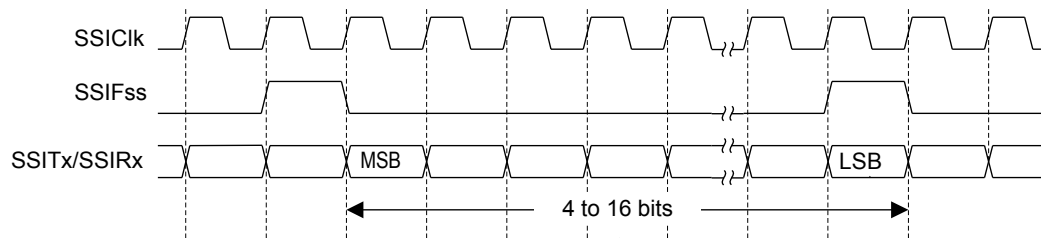
Figure 14-3. TI Synchronous Serial Frame Format (Continuous Transfer)

14.3.4.2 Freescale SPI Frame Format

The Freescale SPI interface is a four-wire interface where the $SSIFss$ signal behaves as a slave select. The main feature of the Freescale SPI format is that the inactive state and phase of the $SSIClk$ signal are programmable through the SPO and SPH bits in the **SSISCR0** control register.

SPO Clock Polarity Bit

When the SPO clock polarity control bit is clear, it produces a steady state Low value on the $SSIClk$ pin. If the SPO bit is set, a steady state High value is placed on the $SSIClk$ pin when data is not being transferred.

SPH Phase Control Bit

The *SPH* phase control bit selects the clock edge that captures data and allows it to change state. The state of this bit has the most impact on the first bit transmitted by either allowing or not allowing a clock transition before the first data capture edge. When the *SPH* phase control bit is clear, data is captured on the first clock edge transition. If the *SPH* bit is set, data is captured on the second clock edge transition.

14.3.4.3 Freescale SPI Frame Format with *SPO=0* and *SPH=0*

Single and continuous transmission signal sequences for Freescale SPI format with *SPO=0* and *SPH=0* are shown in Figure 14-4 on page 924 and Figure 14-5 on page 924.

Figure 14-4. Freescale SPI Format (Single Transfer) with *SPO=0* and *SPH=0*

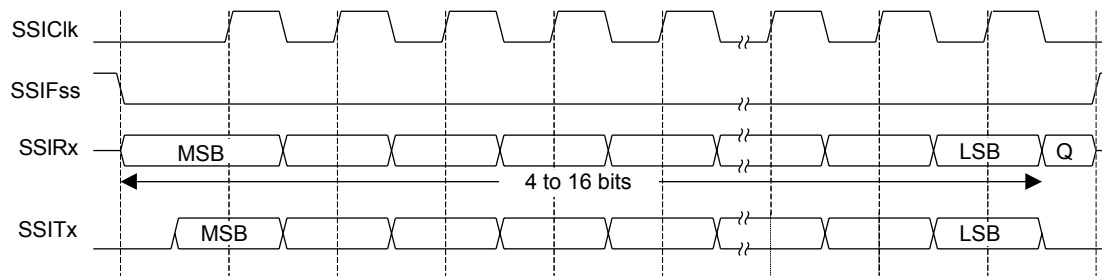

Note: Q is undefined.

Figure 14-5. Freescale SPI Format (Continuous Transfer) with *SPO=0* and *SPH=0*

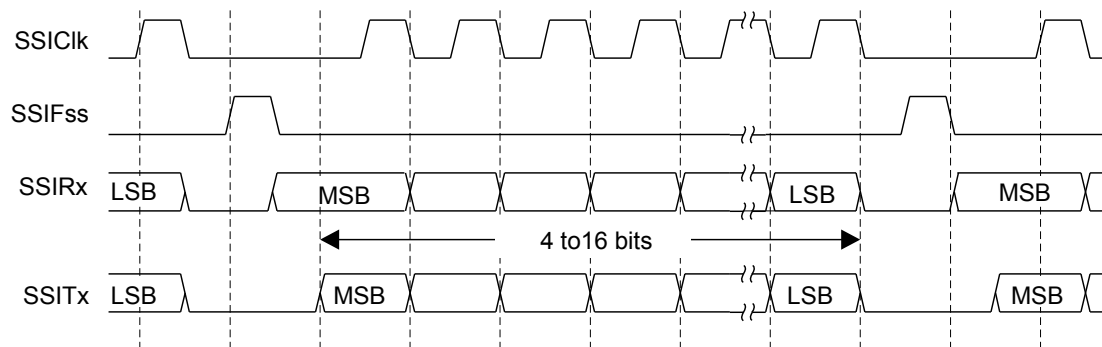

In this configuration, during idle periods:

- *SSIClk* is forced Low
- *SSIFss* is forced High
- The transmit data line *SSITx* is arbitrarily forced Low
- When the SSI is configured as a master, it enables the *SSIClk* pad
- When the SSI is configured as a slave, it disables the *SSIClk* pad

If the SSI is enabled and valid data is in the transmit FIFO, the start of transmission is signified by the *SSIFss* master signal being driven Low, causing slave data to be enabled onto the *SSIRx* input line of the master. The master *SSITx* output pad is enabled.

One half $SSIClk$ period later, valid master data is transferred to the $SSITx$ pin. Once both the master and slave data have been set, the $SSIClk$ master clock pin goes High after one additional half $SSIClk$ period.

The data is now captured on the rising and propagated on the falling edges of the $SSIClk$ signal.

In the case of a single word transmission, after all bits of the data word have been transferred, the $SSIFss$ line is returned to its idle High state one $SSIClk$ period after the last bit has been captured.

However, in the case of continuous back-to-back transmissions, the $SSIFss$ signal must be pulsed High between each data word transfer because the slave select pin freezes the data in its serial peripheral register and does not allow it to be altered if the SPH bit is clear. Therefore, the master device must raise the $SSIFss$ pin of the slave device between each data transfer to enable the serial peripheral data write. On completion of the continuous transfer, the $SSIFss$ pin is returned to its idle state one $SSIClk$ period after the last bit has been captured.

14.3.4.4 Freescale SPI Frame Format with $SPO=0$ and $SPH=1$

The transfer signal sequence for Freescale SPI format with $SPO=0$ and $SPH=1$ is shown in Figure 14-6 on page 925, which covers both single and continuous transfers.

Figure 14-6. Freescale SPI Frame Format with $SPO=0$ and $SPH=1$

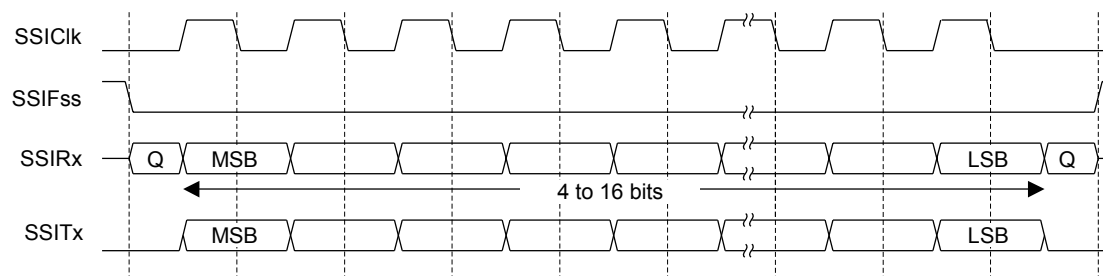

Note: Q is undefined.

In this configuration, during idle periods:

- $SSIClk$ is forced Low
- $SSIFss$ is forced High
- The transmit data line $SSITx$ is arbitrarily forced Low
- When the SSI is configured as a master, it enables the $SSIClk$ pad
- When the SSI is configured as a slave, it disables the $SSIClk$ pad

If the SSI is enabled and valid data is in the transmit FIFO, the start of transmission is signified by the $SSIFss$ master signal being driven Low. The master $SSITx$ output is enabled. After an additional one-half $SSIClk$ period, both master and slave valid data are enabled onto their respective transmission lines. At the same time, the $SSIClk$ is enabled with a rising edge transition.

Data is then captured on the falling edges and propagated on the rising edges of the $SSIClk$ signal.

In the case of a single word transfer, after all bits have been transferred, the $SSIFss$ line is returned to its idle High state one $SSIClk$ period after the last bit has been captured.

For continuous back-to-back transfers, the $SSIF_{SS}$ pin is held Low between successive data words, and termination is the same as that of the single word transfer.

14.3.4.5 Freescale SPI Frame Format with $SPO=1$ and $SPH=0$

Single and continuous transmission signal sequences for Freescale SPI format with $SPO=1$ and $SPH=0$ are shown in Figure 14-7 on page 926 and Figure 14-8 on page 926.

Figure 14-7. Freescale SPI Frame Format (Single Transfer) with $SPO=1$ and $SPH=0$

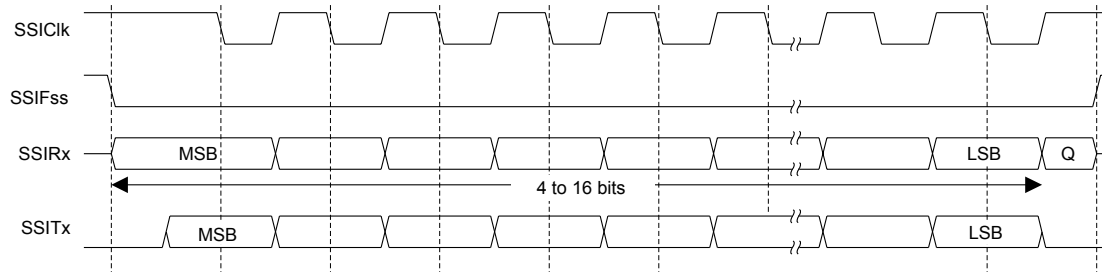

Note: Q is undefined.

Figure 14-8. Freescale SPI Frame Format (Continuous Transfer) with $SPO=1$ and $SPH=0$

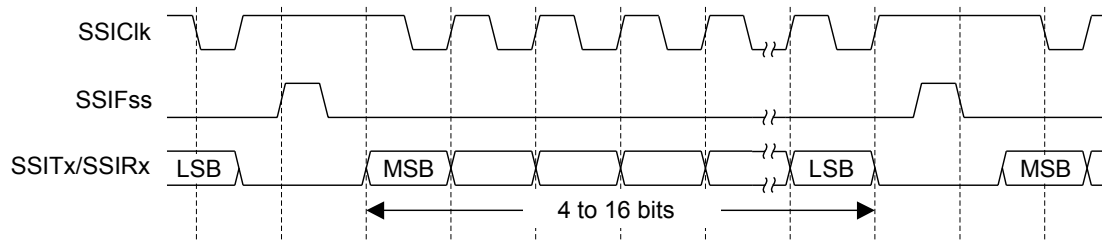

In this configuration, during idle periods:

- $SSIClk$ is forced High
- $SSIF_{SS}$ is forced High
- The transmit data line $SSITx$ is arbitrarily forced Low
- When the SSI is configured as a master, it enables the $SSIClk$ pad
- When the SSI is configured as a slave, it disables the $SSIClk$ pad

If the SSI is enabled and valid data is in the transmit FIFO, the start of transmission is signified by the $SSIF_{SS}$ master signal being driven Low, causing slave data to be immediately transferred onto the $SSIRx$ line of the master. The master $SSITx$ output pad is enabled.

One-half period later, valid master data is transferred to the $SSITx$ line. Once both the master and slave data have been set, the $SSIClk$ master clock pin becomes Low after one additional half $SSIClk$ period, meaning that data is captured on the falling edges and propagated on the rising edges of the $SSIClk$ signal.

In the case of a single word transmission, after all bits of the data word are transferred, the $SSIF_{SS}$ line is returned to its idle High state one $SSIClk$ period after the last bit has been captured.

However, in the case of continuous back-to-back transmissions, the $SSIF_{SS}$ signal must be pulsed High between each data word transfer because the slave select pin freezes the data in its serial peripheral register and does not allow it to be altered if the SPH bit is clear. Therefore, the master device must raise the $SSIF_{SS}$ pin of the slave device between each data transfer to enable the serial peripheral data write. On completion of the continuous transfer, the $SSIF_{SS}$ pin is returned to its idle state one $SSIClk$ period after the last bit has been captured.

14.3.4.6 Freescale SPI Frame Format with $SPO=1$ and $SPH=1$

The transfer signal sequence for Freescale SPI format with $SPO=1$ and $SPH=1$ is shown in Figure 14-9 on page 927, which covers both single and continuous transfers.

Figure 14-9. Freescale SPI Frame Format with $SPO=1$ and $SPH=1$

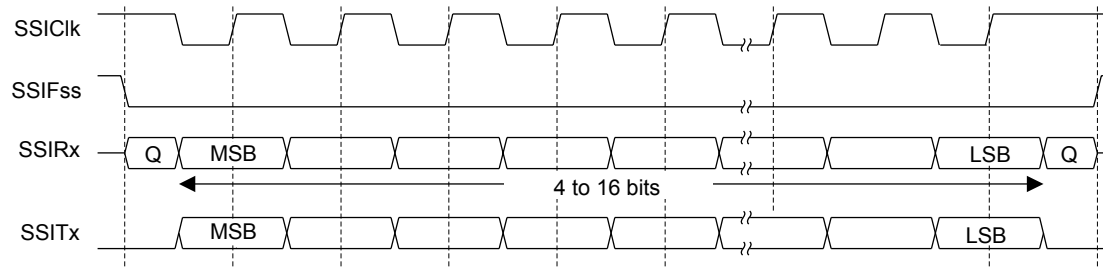

Note: Q is undefined.

In this configuration, during idle periods:

- $SSIClk$ is forced High
- $SSIF_{SS}$ is forced High
- The transmit data line $SSITx$ is arbitrarily forced Low
- When the SSI is configured as a master, it enables the $SSIClk$ pad
- When the SSI is configured as a slave, it disables the $SSIClk$ pad

If the SSI is enabled and valid data is in the transmit FIFO, the start of transmission is signified by the $SSIF_{SS}$ master signal being driven Low. The master $SSITx$ output pad is enabled. After an additional one-half $SSIClk$ period, both master and slave data are enabled onto their respective transmission lines. At the same time, $SSIClk$ is enabled with a falling edge transition. Data is then captured on the rising edges and propagated on the falling edges of the $SSIClk$ signal.

After all bits have been transferred, in the case of a single word transmission, the $SSIF_{SS}$ line is returned to its idle high state one $SSIClk$ period after the last bit has been captured.

For continuous back-to-back transmissions, the $SSIF_{SS}$ pin remains in its active Low state until the final bit of the last word has been captured and then returns to its idle state as described above.

For continuous back-to-back transfers, the $SSIF_{SS}$ pin is held Low between successive data words and termination is the same as that of the single word transfer.

14.3.4.7 MICROWIRE Frame Format

Figure 14-10 on page 928 shows the MICROWIRE frame format for a single frame. Figure 14-11 on page 929 shows the same format when back-to-back frames are transmitted.

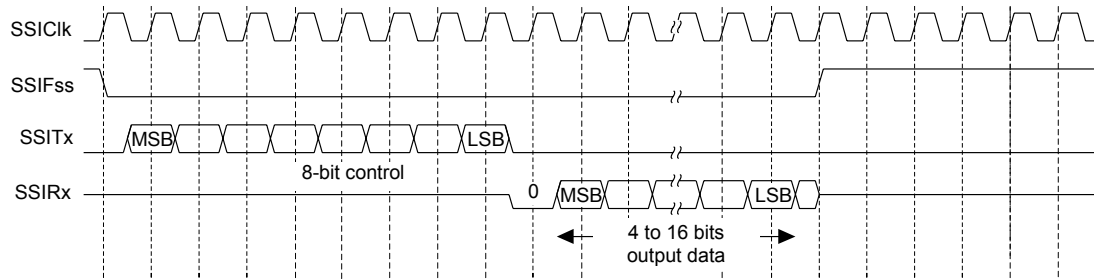
Figure 14-10. MICROWIRE Frame Format (Single Frame)

MICROWIRE format is very similar to SPI format, except that transmission is half-duplex instead of full-duplex and uses a master-slave message passing technique. Each serial transmission begins with an 8-bit control word that is transmitted from the SSI to the off-chip slave device. During this transmission, no incoming data is received by the SSI. After the message has been sent, the off-chip slave decodes it and, after waiting one serial clock after the last bit of the 8-bit control message has been sent, responds with the required data. The returned data is 4 to 16 bits in length, making the total frame length anywhere from 13 to 25 bits.

In this configuration, during idle periods:

- SSIClk is forced Low
- SSIFss is forced High
- The transmit data line SSITx is arbitrarily forced Low

A transmission is triggered by writing a control byte to the transmit FIFO. The falling edge of SSIFss causes the value contained in the bottom entry of the transmit FIFO to be transferred to the serial shift register of the transmit logic and the MSB of the 8-bit control frame to be shifted out onto the SSITx pin. SSIFss remains Low for the duration of the frame transmission. The SSIRx pin remains tristated during this transmission.

The off-chip serial slave device latches each control bit into its serial shifter on each rising edge of SSIClk. After the last bit is latched by the slave device, the control byte is decoded during a one clock wait-state, and the slave responds by transmitting data back to the SSI. Each bit is driven onto the SSIRx line on the falling edge of SSIClk. The SSI in turn latches each bit on the rising edge of SSIClk. At the end of the frame, for single transfers, the SSIFss signal is pulled High one clock period after the last bit has been latched in the receive serial shifter, causing the data to be transferred to the receive FIFO.

Note: The off-chip slave device can tristate the receive line either on the falling edge of SSIClk after the LSB has been latched by the receive shifter or when the SSIFss pin goes High.

For continuous transfers, data transmission begins and ends in the same manner as a single transfer. However, the SSIFss line is continuously asserted (held Low) and transmission of data occurs back-to-back. The control byte of the next frame follows directly after the LSB of the received data from the current frame. Each of the received values is transferred from the receive shifter on the falling edge of SSIClk, after the LSB of the frame has been latched into the SSI.

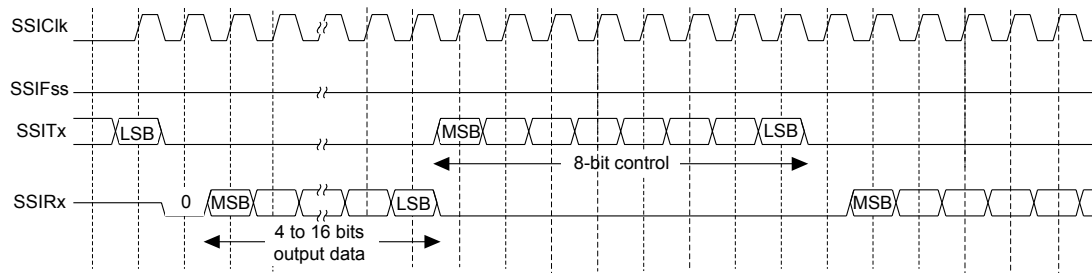
Figure 14-11. MICROWIRE Frame Format (Continuous Transfer)

In the MICROWIRE mode, the SSI slave samples the first bit of receive data on the rising edge of `SSIClk` after `SSIFss` has gone Low. Masters that drive a free-running `SSIClk` must ensure that the `SSIFss` signal has sufficient setup and hold margins with respect to the rising edge of `SSIClk`.

Figure 14-12 on page 929 illustrates these setup and hold time requirements. With respect to the `SSIClk` rising edge on which the first bit of receive data is to be sampled by the SSI slave, `SSIFss` must have a setup of at least two times the period of `SSIClk` on which the SSI operates. With respect to the `SSIClk` rising edge previous to this edge, `SSIFss` must have a hold of at least one `SSIClk` period.

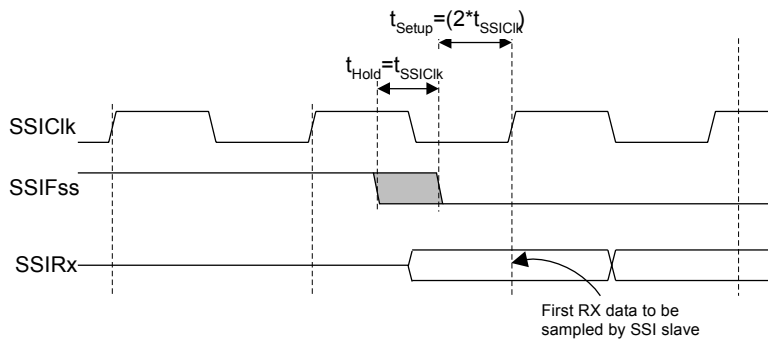
Figure 14-12. MICROWIRE Frame Format, SSIFss Input Setup and Hold Requirements

14.3.5 DMA Operation

The SSI peripheral provides an interface to the μ DMA controller with separate channels for transmit and receive. The μ DMA operation of the SSI is enabled through the **SSI DMA Control (SSIDMACTL)** register. When μ DMA operation is enabled, the SSI asserts a μ DMA request on the receive or transmit channel when the associated FIFO can transfer data. For the receive channel, a single transfer request is asserted whenever any data is in the receive FIFO. A burst transfer request is asserted whenever the amount of data in the receive FIFO is 4 or more items. For the transmit channel, a single transfer request is asserted whenever at least one empty location is in the transmit FIFO. The burst request is asserted whenever the transmit FIFO has 4 or more empty slots. The single and burst μ DMA transfer requests are handled automatically by the μ DMA controller depending how the μ DMA channel is configured. To enable μ DMA operation for the receive channel, the `RXDMAE` bit of the **DMA Control (SSIDMACTL)** register should be set. To enable μ DMA operation for the transmit channel, the `TXDMAE` bit of **SSIDMACTL** should be set. If μ DMA is enabled, then the μ DMA controller triggers an interrupt when a transfer is complete. The interrupt occurs on the SSI interrupt vector. Therefore, if interrupts are used for SSI operation and μ DMA is enabled, the SSI interrupt handler must be designed to handle the μ DMA completion interrupt.

See “Micro Direct Memory Access (μ DMA)” on page 559 for more details about programming the μ DMA controller.

14.4 Initialization and Configuration

To enable and initialize the SSI, the following steps are necessary:

1. Enable the SSI module using the **RCGCSSI** register (see page 324).
2. Enable the clock to the appropriate GPIO module via the **RCGCGPIO** register (see page 319). To find out which GPIO port to enable, refer to Table 22-5 on page 1314.
3. Set the GPIO **AFSEL** bits for the appropriate pins (see page 644). To determine which GPIOs to configure, see Table 22-4 on page 1307.
4. Configure the **PMCn** fields in the **GPIOPCTL** register to assign the SSI signals to the appropriate pins. See page 661 and Table 22-5 on page 1314.

For each of the frame formats, the SSI is configured using the following steps:

1. Ensure that the **SSE** bit in the **SSICR1** register is clear before making any configuration changes.
2. Select whether the SSI is a master or slave:
 - a. For master operations, set the **SSICR1** register to 0x0000.0000.
 - b. For slave mode (output enabled), set the **SSICR1** register to 0x0000.0004.
 - c. For slave mode (output disabled), set the **SSICR1** register to 0x0000.000C.
3. Configure the SSI clock source by writing to the **SSICC** register.
4. Configure the clock prescale divisor by writing the **SSICPSR** register.
5. Write the **SSICR0** register with the following configuration:
 - Serial clock rate (**SCR**)
 - Desired clock phase/polarity, if using Freescale SPI mode (**SPH** and **SPO**)
 - The protocol mode: Freescale SPI, TI SSF, MICROWIRE (**FRF**)
 - The data size (**DSS**)
6. Optionally, configure the μ DMA channel (see “Micro Direct Memory Access (μ DMA)” on page 559) and enable the DMA option(s) in the **SSIDMACTL** register.
7. Enable the SSI by setting the **SSE** bit in the **SSICR1** register.

As an example, assume the SSI must be configured to operate with the following parameters:

- Master operation
- Freescale SPI mode (**SPO**=1, **SPH**=1)
- 1 Mbps bit rate

- 8 data bits

Assuming the system clock is 20 MHz, the bit rate calculation would be:

$$\text{SSIClk} = \text{SysClk} / (\text{CPSDVSR} * (1 + \text{SCR}))$$

$$1 \times 10^6 = 20 \times 10^6 / (\text{CPSDVSR} * (1 + \text{SCR}))$$

In this case, if CPSDVSR=0x2, SCR must be 0x9.

The configuration sequence would be as follows:

1. Ensure that the SSE bit in the **SSICR1** register is clear.
2. Write the **SSICR1** register with a value of 0x0000.0000.
3. Write the **SSICPSR** register with a value of 0x0000.0002.
4. Write the **SSICR0** register with a value of 0x0000.09C7.
5. The SSI is then enabled by setting the SSE bit in the **SSICR1** register.

14.5 Register Map

Table 14-2 on page 931 lists the SSI registers. The offset listed is a hexadecimal increment to the register's address, relative to that SSI module's base address:

- SSI0: 0x4000.8000
- SSI1: 0x4000.9000
- SSI2: 0x4000.A000
- SSI3: 0x4000.B000

Note that the SSI module clock must be enabled before the registers can be programmed (see page 324). There must be a delay of 3 system clocks after the SSI module clock is enabled before any SSI module registers are accessed.

Note: The SSI must be disabled (see the SSE bit in the **SSICR1** register) before any of the control registers are reprogrammed.

Table 14-2. SSI Register Map

Offset	Name	Type	Reset	Description	See page
0x000	SSICR0	R/W	0x0000.0000	SSI Control 0	933
0x004	SSICR1	R/W	0x0000.0000	SSI Control 1	935
0x008	SSIDR	R/W	0x0000.0000	SSI Data	937
0x00C	SSISR	RO	0x0000.0003	SSI Status	938
0x010	SSICPSR	R/W	0x0000.0000	SSI Clock Prescale	940
0x014	SSIIM	R/W	0x0000.0000	SSI Interrupt Mask	941
0x018	SSIRIS	RO	0x0000.0008	SSI Raw Interrupt Status	942
0x01C	SSIMIS	RO	0x0000.0000	SSI Masked Interrupt Status	944
0x020	SSIICR	W1C	0x0000.0000	SSI Interrupt Clear	946

Table 14-2. SSI Register Map (continued)

Offset	Name	Type	Reset	Description	See page
0x024	SSIDMACTL	R/W	0x0000.0000	SSI DMA Control	947
0xFC8	SSICC	R/W	0x0000.0000	SSI Clock Configuration	948
0xFD0	SSIPeriphID4	RO	0x0000.0000	SSI Peripheral Identification 4	949
0xFD4	SSIPeriphID5	RO	0x0000.0000	SSI Peripheral Identification 5	950
0xFD8	SSIPeriphID6	RO	0x0000.0000	SSI Peripheral Identification 6	951
0xFDC	SSIPeriphID7	RO	0x0000.0000	SSI Peripheral Identification 7	952
0xFE0	SSIPeriphID0	RO	0x0000.0022	SSI Peripheral Identification 0	953
0xFE4	SSIPeriphID1	RO	0x0000.0000	SSI Peripheral Identification 1	954
0xFE8	SSIPeriphID2	RO	0x0000.0018	SSI Peripheral Identification 2	955
0xFEC	SSIPeriphID3	RO	0x0000.0001	SSI Peripheral Identification 3	956
0xFF0	SSIPCellID0	RO	0x0000.000D	SSI PrimeCell Identification 0	957
0xFF4	SSIPCellID1	RO	0x0000.00F0	SSI PrimeCell Identification 1	958
0xFF8	SSIPCellID2	RO	0x0000.0005	SSI PrimeCell Identification 2	959
0xFFC	SSIPCellID3	RO	0x0000.00B1	SSI PrimeCell Identification 3	960

14.6 Register Descriptions

The remainder of this section lists and describes the SSI registers, in numerical order by address offset.

Register 1: SSI Control 0 (SSICR0), offset 0x000

The **SSICR0** register contains bit fields that control various functions within the SSI module. Functionality such as protocol mode, clock rate, and data size are configured in this register.

SSI Control 0 (SSICR0)

SSI0 base: 0x4000.8000
 SSI1 base: 0x4000.9000
 SSI2 base: 0x4000.A000
 SSI3 base: 0x4000.B000
 Offset 0x000
 Type R/W, reset 0x0000.0000

	31	30	29	28	27	26	25	24	23	22	21	20	19	18	17	16
	reserved															
Type	RO	RO	RO	RO	RO	RO	RO	RO	RO	RO	RO	RO	RO	RO	RO	RO
Reset	0	0	0	0	0	0	0	0	0	0	0	0	0	0	0	0
	15	14	13	12	11	10	9	8	7	6	5	4	3	2	1	0
	SCR								SPH	SPO	FRF		DSS			
Type	R/W	R/W	R/W	R/W	R/W	R/W	R/W	R/W	R/W	R/W	R/W	R/W	R/W	R/W	R/W	R/W
Reset	0	0	0	0	0	0	0	0	0	0	0	0	0	0	0	0

Bit/Field	Name	Type	Reset	Description
31:16	reserved	RO	0x0000	Software should not rely on the value of a reserved bit. To provide compatibility with future products, the value of a reserved bit should be preserved across a read-modify-write operation.
15:8	SCR	R/W	0x00	SSI Serial Clock Rate This bit field is used to generate the transmit and receive bit rate of the SSI. The bit rate is: $BR = SysClk / (CPSDVSR * (1 + SCR))$ where CPSDVSR is an even value from 2-254 programmed in the SSICPSR register, and SCR is a value from 0-255.
7	SPH	R/W	0	SSI Serial Clock Phase This bit is only applicable to the Freescale SPI Format. The SPH control bit selects the clock edge that captures data and allows it to change state. This bit has the most impact on the first bit transmitted by either allowing or not allowing a clock transition before the first data capture edge. Value Description 0 Data is captured on the first clock edge transition. 1 Data is captured on the second clock edge transition.
6	SPO	R/W	0	SSI Serial Clock Polarity Value Description 0 A steady state Low value is placed on the SSIClk pin. 1 A steady state High value is placed on the SSIClk pin when data is not being transferred.

Bit/Field	Name	Type	Reset	Description
5:4	FRF	R/W	0x0	SSI Frame Format Select Value Frame Format 0x0 Freescale SPI Frame Format 0x1 Texas Instruments Synchronous Serial Frame Format 0x2 MICROWIRE Frame Format 0x3 Reserved
3:0	DSS	R/W	0x0	SSI Data Size Select Value Data Size 0x0-0x2 Reserved 0x3 4-bit data 0x4 5-bit data 0x5 6-bit data 0x6 7-bit data 0x7 8-bit data 0x8 9-bit data 0x9 10-bit data 0xA 11-bit data 0xB 12-bit data 0xC 13-bit data 0xD 14-bit data 0xE 15-bit data 0xF 16-bit data

Register 2: SSI Control 1 (SSICR1), offset 0x004

The **SSICR1** register contains bit fields that control various functions within the SSI module. Master and slave mode functionality is controlled by this register.

SSI Control 1 (SSICR1)

SSI0 base: 0x4000.8000
 SSI1 base: 0x4000.9000
 SSI2 base: 0x4000.A000
 SSI3 base: 0x4000.B000
 Offset 0x004
 Type R/W, reset 0x0000.0000

	31	30	29	28	27	26	25	24	23	22	21	20	19	18	17	16
	reserved															
Type	RO	RO	RO	RO	RO	RO	RO	RO	RO	RO	RO	RO	RO	RO	RO	RO
Reset	0	0	0	0	0	0	0	0	0	0	0	0	0	0	0	0
	15	14	13	12	11	10	9	8	7	6	5	4	3	2	1	0
	reserved										SLBY6	EOT	SOD	MS	SSE	LBM
Type	RO	RO	RO	RO	RO	RO	RO	RO	RO	RO	R/W	R/W	R/W	R/W	R/W	R/W
Reset	0	0	0	0	0	0	0	0	0	0	0	0	0	0	0	0

Bit/Field	Name	Type	Reset	Description
31:6	reserved	RO	0x0000.0	Software should not rely on the value of a reserved bit. To provide compatibility with future products, the value of a reserved bit should be preserved across a read-modify-write operation.
5	SLBY6	R/W	0	Slave Bypass Mode Value Description 0 SSI Module operates standard mode such that the slave is clocked at a 12:1 ratio of system clock to SSInCLK. 1 SSI module functions such that the slave operates at a 6:1 ratio of system clock to SSInCLK.
4	EOT	R/W	0	End of Transmission Value Description 0 The TXRIS interrupt indicates that the transmit FIFO is half full or less. 1 The End of Transmit interrupt mode for the TXRIS interrupt is enabled.
3	SOD	R/W	0	SSI Slave Mode Output Disable This bit is relevant only in the Slave mode (MS=1). In multiple-slave systems, it is possible for the SSI master to broadcast a message to all slaves in the system while ensuring that only one slave drives data onto the serial output line. In such systems, the TXD lines from multiple slaves could be tied together. To operate in such a system, the SOD bit can be configured so that the SSI slave does not drive the SSITx pin. Value Description 0 SSI can drive the SSITx output in Slave mode. 1 SSI must not drive the SSITx output in Slave mode.

Bit/Field	Name	Type	Reset	Description
2	MS	R/W	0	<p>SSI Master/Slave Select</p> <p>This bit selects Master or Slave mode and can be modified only when the SSI is disabled (<i>SSE</i>=0).</p> <p>Value Description</p> <p>0 The SSI is configured as a master.</p> <p>1 The SSI is configured as a slave.</p>
1	SSE	R/W	0	<p>SSI Synchronous Serial Port Enable</p> <p>Value Description</p> <p>0 SSI operation is disabled.</p> <p>1 SSI operation is enabled.</p> <p>Note: This bit must be cleared before any control registers are reprogrammed.</p>
0	LBM	R/W	0	<p>SSI Loopback Mode</p> <p>Value Description</p> <p>0 Normal serial port operation enabled.</p> <p>1 Output of the transmit serial shift register is connected internally to the input of the receive serial shift register.</p>

Register 3: SSI Data (SSIDR), offset 0x008

Important: This register is read-sensitive. See the register description for details.

The **SSIDR** register is 16-bits wide. When the **SSIDR** register is read, the entry in the receive FIFO that is pointed to by the current FIFO read pointer is accessed. When a data value is removed by the SSI receive logic from the incoming data frame, it is placed into the entry in the receive FIFO pointed to by the current FIFO write pointer.

When the **SSIDR** register is written to, the entry in the transmit FIFO that is pointed to by the write pointer is written to. Data values are removed from the transmit FIFO one value at a time by the transmit logic. Each data value is loaded into the transmit serial shifter, then serially shifted out onto the **SSITx** pin at the programmed bit rate.

When a data size of less than 16 bits is selected, the user must right-justify data written to the transmit FIFO. The transmit logic ignores the unused bits. Received data less than 16 bits is automatically right-justified in the receive buffer.

When the SSI is programmed for MICROWIRE frame format, the default size for transmit data is eight bits (the most significant byte is ignored). The receive data size is controlled by the programmer. The transmit FIFO and the receive FIFO are not cleared even when the **SSE** bit in the **SSICR1** register is cleared, allowing the software to fill the transmit FIFO before enabling the SSI.

SSI Data (SSIDR)

SSI0 base: 0x4000.8000
 SSI1 base: 0x4000.9000
 SSI2 base: 0x4000.A000
 SSI3 base: 0x4000.B000
 Offset 0x008
 Type R/W, reset 0x0000.0000

	31	30	29	28	27	26	25	24	23	22	21	20	19	18	17	16
	reserved															
Type	RO	RO	RO	RO	RO	RO	RO	RO	RO	RO	RO	RO	RO	RO	RO	RO
Reset	0	0	0	0	0	0	0	0	0	0	0	0	0	0	0	0
	15	14	13	12	11	10	9	8	7	6	5	4	3	2	1	0
	DATA															
Type	R/W	R/W	R/W	R/W	R/W	R/W	R/W	R/W	R/W	R/W	R/W	R/W	R/W	R/W	R/W	R/W
Reset	0	0	0	0	0	0	0	0	0	0	0	0	0	0	0	0

Bit/Field	Name	Type	Reset	Description
31:16	reserved	RO	0x0000	Software should not rely on the value of a reserved bit. To provide compatibility with future products, the value of a reserved bit should be preserved across a read-modify-write operation.
15:0	DATA	R/W	0x0000	SSI Receive/Transmit Data A read operation reads the receive FIFO. A write operation writes the transmit FIFO. Software must right-justify data when the SSI is programmed for a data size that is less than 16 bits. Unused bits at the top are ignored by the transmit logic. The receive logic automatically right-justifies the data.

Register 4: SSI Status (SSISR), offset 0x00C

The **SSISR** register contains bits that indicate the FIFO fill status and the SSI busy status.

SSI Status (SSISR)

SSI0 base: 0x4000.8000
 SSI1 base: 0x4000.9000
 SSI2 base: 0x4000.A000
 SSI3 base: 0x4000.B000
 Offset 0x00C
 Type RO, reset 0x0000.0003

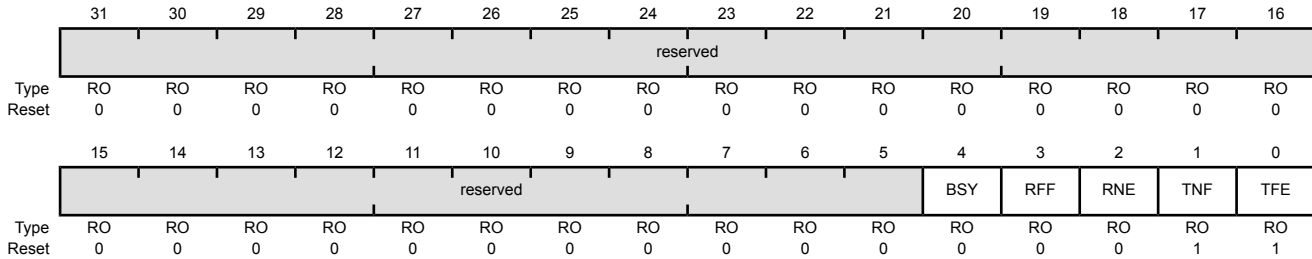

Bit/Field	Name	Type	Reset	Description
31:5	reserved	RO	0x0000.00	Software should not rely on the value of a reserved bit. To provide compatibility with future products, the value of a reserved bit should be preserved across a read-modify-write operation.
4	BSY	RO	0	SSI Busy Bit Value Description 0 The SSI is idle. 1 The SSI is currently transmitting and/or receiving a frame, or the transmit FIFO is not empty.
3	RFF	RO	0	SSI Receive FIFO Full Value Description 0 The receive FIFO is not full. 1 The receive FIFO is full.
2	RNE	RO	0	SSI Receive FIFO Not Empty Value Description 0 The receive FIFO is empty. 1 The receive FIFO is not empty.
1	TNF	RO	1	SSI Transmit FIFO Not Full Value Description 0 The transmit FIFO is full. 1 The transmit FIFO is not full.

Bit/Field	Name	Type	Reset	Description
0	TFE	RO	1	SSI Transmit FIFO Empty
				Value Description
				0 The transmit FIFO is not empty.
				1 The transmit FIFO is empty.

Register 5: SSI Clock Prescale (SSICPSR), offset 0x010

The **SSICPSR** register specifies the division factor which is used to derive the **SSIClk** from the system clock. The clock is further divided by a value from 1 to 256, which is $1 + \text{SCR}$. **SCR** is programmed in the **SSICR0** register. The frequency of the **SSIClk** is defined by:

$$\text{SSIClk} = \text{SysClk} / (\text{CPSDVSR} * (1 + \text{SCR}))$$

The value programmed into this register must be an even number between 2 and 254. The least-significant bit of the programmed number is hard-coded to zero. If an odd number is written to this register, data read back from this register has the least-significant bit as zero.

SSI Clock Prescale (SSICPSR)

SSI0 base: 0x4000.8000
 SSI1 base: 0x4000.9000
 SSI2 base: 0x4000.A000
 SSI3 base: 0x4000.B000
 Offset 0x010
 Type R/W, reset 0x0000.0000

	31	30	29	28	27	26	25	24	23	22	21	20	19	18	17	16
	reserved															
Type	RO	RO	RO	RO	RO	RO	RO	RO	RO	RO	RO	RO	RO	RO	RO	RO
Reset	0	0	0	0	0	0	0	0	0	0	0	0	0	0	0	0
	15	14	13	12	11	10	9	8	7	6	5	4	3	2	1	0
	reserved								CPSDVSR							
Type	RO	RO	RO	RO	RO	RO	RO	RO	R/W	R/W	R/W	R/W	R/W	R/W	R/W	R/W
Reset	0	0	0	0	0	0	0	0	0	0	0	0	0	0	0	0

Bit/Field	Name	Type	Reset	Description
31:8	reserved	RO	0x00	Software should not rely on the value of a reserved bit. To provide compatibility with future products, the value of a reserved bit should be preserved across a read-modify-write operation.
7:0	CPSDVSR	R/W	0x00	SSI Clock Prescale Divisor This value must be an even number from 2 to 254, depending on the frequency of SSIClk . The LSB always returns 0 on reads.

Register 6: SSI Interrupt Mask (SSIIM), offset 0x014

The **SSIIM** register is the interrupt mask set or clear register. It is a read/write register and all bits are cleared on reset.

On a read, this register gives the current value of the mask on the corresponding interrupt. Setting a bit sets the mask, preventing the interrupt from being signaled to the interrupt controller. Clearing a bit clears the corresponding mask, enabling the interrupt to be sent to the interrupt controller.

SSI Interrupt Mask (SSIIM)

SSI0 base: 0x4000.8000
 SSI1 base: 0x4000.9000
 SSI2 base: 0x4000.A000
 SSI3 base: 0x4000.B000
 Offset 0x014
 Type R/W, reset 0x0000.0000

	31	30	29	28	27	26	25	24	23	22	21	20	19	18	17	16	
	reserved																
Type	RO	RO	RO	RO	RO	RO	RO	RO	RO	RO	RO	RO	RO	RO	RO	RO	
Reset	0	0	0	0	0	0	0	0	0	0	0	0	0	0	0	0	
	15	14	13	12	11	10	9	8	7	6	5	4	3	2	1	0	
	reserved													TXIM	RXIM	RTIM	RORIM
Type	RO	RO	RO	RO	RO	RO	RO	RO	RO	RO	RO	RO	RO	R/W	R/W	R/W	R/W
Reset	0	0	0	0	0	0	0	0	0	0	0	0	0	0	0	0	0

Bit/Field	Name	Type	Reset	Description
31:4	reserved	RO	0	Software should not rely on the value of a reserved bit. To provide compatibility with future products, the value of a reserved bit should be preserved across a read-modify-write operation.
3	TXIM	R/W	0	SSI Transmit FIFO Interrupt Mask Value Description 0 The transmit FIFO interrupt is masked. 1 The transmit FIFO interrupt is not masked.
2	RXIM	R/W	0	SSI Receive FIFO Interrupt Mask Value Description 0 The receive FIFO interrupt is masked. 1 The receive FIFO interrupt is not masked.
1	RTIM	R/W	0	SSI Receive Time-Out Interrupt Mask Value Description 0 The receive FIFO time-out interrupt is masked. 1 The receive FIFO time-out interrupt is not masked.
0	RORIM	R/W	0	SSI Receive Overrun Interrupt Mask Value Description 0 The receive FIFO overrun interrupt is masked. 1 The receive FIFO overrun interrupt is not masked.

Register 7: SSI Raw Interrupt Status (SSIRIS), offset 0x018

The **SSIRIS** register is the raw interrupt status register. On a read, this register gives the current raw status value of the corresponding interrupt prior to masking. A write has no effect.

SSI Raw Interrupt Status (SSIRIS)

SSI0 base: 0x4000.8000
 SSI1 base: 0x4000.9000
 SSI2 base: 0x4000.A000
 SSI3 base: 0x4000.B000
 Offset 0x018
 Type RO, reset 0x0000.0008

	31	30	29	28	27	26	25	24	23	22	21	20	19	18	17	16
	reserved															
Type	RO	RO	RO	RO	RO	RO	RO	RO	RO	RO	RO	RO	RO	RO	RO	RO
Reset	0	0	0	0	0	0	0	0	0	0	0	0	0	0	0	0
	15	14	13	12	11	10	9	8	7	6	5	4	3	2	1	0
	reserved												TXRIS	RXRIS	RTRIS	RORRIS
Type	RO	RO	RO	RO	RO	RO	RO	RO	RO	RO	RO	RO	RO	RO	RO	RO
Reset	0	0	0	0	0	0	0	0	0	0	0	0	0	1	0	0

Bit/Field	Name	Type	Reset	Description
31:4	reserved	RO	0	Software should not rely on the value of a reserved bit. To provide compatibility with future products, the value of a reserved bit should be preserved across a read-modify-write operation.
3	TXRIS	RO	1	SSI Transmit FIFO Raw Interrupt Status Value Description 0 No interrupt. 1 If the EOT bit in the SSICR1 register is clear, the transmit FIFO is half empty or less. If the EOT bit is set, the transmit FIFO is empty, and the last bit has been transmitted out of the serializer. This bit is cleared when the transmit FIFO is more than half full (if the EOT bit is clear) or when it has any data in it (if the EOT bit is set).
2	RXRIS	RO	0	SSI Receive FIFO Raw Interrupt Status Value Description 0 No interrupt. 1 The receive FIFO is half full or more. This bit is cleared when the receive FIFO is less than half full.
1	RTRIS	RO	0	SSI Receive Time-Out Raw Interrupt Status Value Description 0 No interrupt. 1 The receive time-out has occurred. This bit is cleared when a 1 is written to the RTIC bit in the SSI Interrupt Clear (SSICR) register.

Bit/Field	Name	Type	Reset	Description
0	RORRIS	RO	0	SSI Receive Overrun Raw Interrupt Status Value Description 0 No interrupt. 1 The receive FIFO has overflowed This bit is cleared when a 1 is written to the RORIC bit in the SSI Interrupt Clear (SSIICR) register.

Register 8: SSI Masked Interrupt Status (SSIMIS), offset 0x01C

The **SSIMIS** register is the masked interrupt status register. On a read, this register gives the current masked status value of the corresponding interrupt. A write has no effect.

SSI Masked Interrupt Status (SSIMIS)

SSI0 base: 0x4000.8000
 SSI1 base: 0x4000.9000
 SSI2 base: 0x4000.A000
 SSI3 base: 0x4000.B000
 Offset 0x01C
 Type RO, reset 0x0000.0000

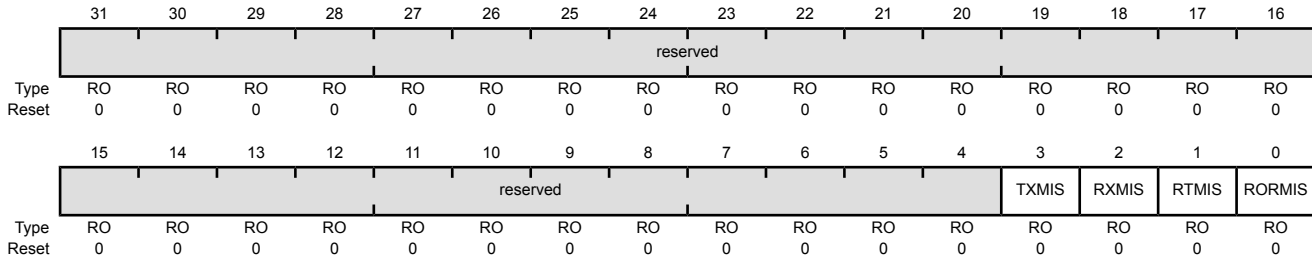

Bit/Field	Name	Type	Reset	Description
31:4	reserved	RO	0	Software should not rely on the value of a reserved bit. To provide compatibility with future products, the value of a reserved bit should be preserved across a read-modify-write operation.
3	TXMIS	RO	0	SSI Transmit FIFO Masked Interrupt Status Value Description 0 An interrupt has not occurred or is masked. 1 An unmasked interrupt was signaled due to the transmit FIFO being half empty or less (if the EOT bit is clear) or due to the transmission of the last data bit (if the EOT bit is set). This bit is cleared when the transmit FIFO is more than half empty (if the EOT bit is clear) or when it has any data in it (if the EOT bit is set).
2	RXMIS	RO	0	SSI Receive FIFO Masked Interrupt Status Value Description 0 An interrupt has not occurred or is masked. 1 An unmasked interrupt was signaled due to the receive FIFO being half full or more. This bit is cleared when the receive FIFO is less than half full.
1	RTMIS	RO	0	SSI Receive Time-Out Masked Interrupt Status Value Description 0 An interrupt has not occurred or is masked. 1 An unmasked interrupt was signaled due to the receive time out. This bit is cleared when a 1 is written to the RTIC bit in the SSI Interrupt Clear (SSIICR) register.

Bit/Field	Name	Type	Reset	Description
0	RORMIS	RO	0	SSI Receive Overrun Masked Interrupt Status Value Description 0 An interrupt has not occurred or is masked. 1 An unmasked interrupt was signaled due to the receive FIFO overflowing. This bit is cleared when a 1 is written to the RORIC bit in the SSI Interrupt Clear (SSIICR) register.

Register 9: SSI Interrupt Clear (SSIICR), offset 0x020

The **SSIICR** register is the interrupt clear register. On a write of 1, the corresponding interrupt is cleared. A write of 0 has no effect.

SSI Interrupt Clear (SSIICR)

SSI0 base: 0x4000.8000
 SSI1 base: 0x4000.9000
 SSI2 base: 0x4000.A000
 SSI3 base: 0x4000.B000
 Offset 0x020
 Type W1C, reset 0x0000.0000

	31	30	29	28	27	26	25	24	23	22	21	20	19	18	17	16	
	reserved																
Type	RO	RO	RO	RO	RO	RO	RO	RO	RO	RO	RO	RO	RO	RO	RO	RO	
Reset	0	0	0	0	0	0	0	0	0	0	0	0	0	0	0	0	
	15	14	13	12	11	10	9	8	7	6	5	4	3	2	1	0	
	reserved														RTIC	RORIC	
Type	RO	RO	RO	RO	RO	RO	RO	RO	RO	RO	RO	RO	RO	RO	RO	W1C	W1C
Reset	0	0	0	0	0	0	0	0	0	0	0	0	0	0	0	0	0

Bit/Field	Name	Type	Reset	Description
31:2	reserved	RO	0	Software should not rely on the value of a reserved bit. To provide compatibility with future products, the value of a reserved bit should be preserved across a read-modify-write operation.
1	RTIC	W1C	0	SSI Receive Time-Out Interrupt Clear Writing a 1 to this bit clears the RTRIS bit in the SSIRIS register and the RTMIS bit in the SSIMIS register.
0	RORIC	W1C	0	SSI Receive Overrun Interrupt Clear Writing a 1 to this bit clears the RORRIS bit in the SSIRIS register and the RORMIS bit in the SSIMIS register.

Register 10: SSI DMA Control (SSIDMACTL), offset 0x024

The **SSIDMACTL** register is the μ DMA control register.

SSI DMA Control (SSIDMACTL)

SSI0 base: 0x4000.8000
 SSI1 base: 0x4000.9000
 SSI2 base: 0x4000.A000
 SSI3 base: 0x4000.B000
 Offset 0x024
 Type R/W, reset 0x0000.0000

	31	30	29	28	27	26	25	24	23	22	21	20	19	18	17	16	
	reserved																
Type	RO	RO	RO	RO	RO	RO	RO	RO	RO	RO	RO	RO	RO	RO	RO	RO	
Reset	0	0	0	0	0	0	0	0	0	0	0	0	0	0	0	0	
	15	14	13	12	11	10	9	8	7	6	5	4	3	2	1	0	
	reserved														TXDMAE	RXDMAE	
Type	RO	RO	RO	RO	RO	RO	RO	RO	RO	RO	RO	RO	RO	RO	RO	R/W	R/W
Reset	0	0	0	0	0	0	0	0	0	0	0	0	0	0	0	0	0

Bit/Field	Name	Type	Reset	Description
31:2	reserved	RO	0x0000.000	Software should not rely on the value of a reserved bit. To provide compatibility with future products, the value of a reserved bit should be preserved across a read-modify-write operation.
1	TXDMAE	R/W	0	Transmit DMA Enable Value Description 0 μ DMA for the transmit FIFO is disabled. 1 μ DMA for the transmit FIFO is enabled.
0	RXDMAE	R/W	0	Receive DMA Enable Value Description 0 μ DMA for the receive FIFO is disabled. 1 μ DMA for the receive FIFO is enabled.

Register 11: SSI Clock Configuration (SSICC), offset 0xFC8

The **SSICC** register controls the baud clock source for the SSI module.

Note: If the PIOSC is used for the SSI baud clock, the system clock frequency must be at least 16 MHz in Run mode.

SSI Clock Configuration (SSICC)

SSI0 base: 0x4000.8000
 SSI1 base: 0x4000.9000
 SSI2 base: 0x4000.A000
 SSI3 base: 0x4000.B000
 Offset 0xFC8
 Type R/W, reset 0x0000.0000

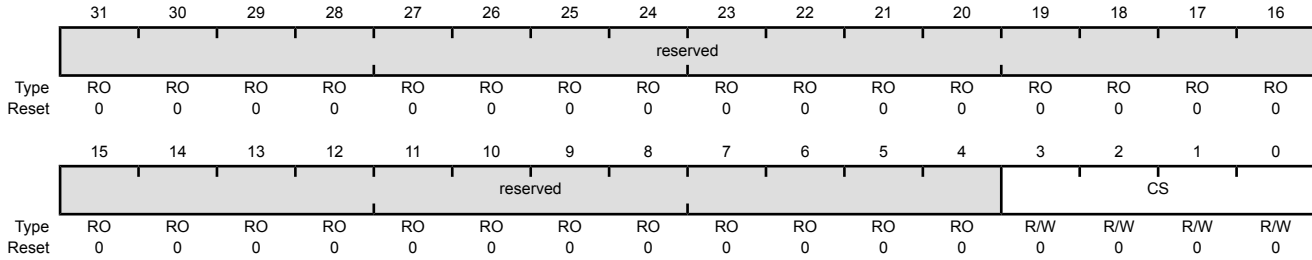

Bit/Field	Name	Type	Reset	Description										
31:4	reserved	RO	0x0000.000	Software should not rely on the value of a reserved bit. To provide compatibility with future products, the value of a reserved bit should be preserved across a read-modify-write operation.										
3:0	CS	R/W	0	SSI Baud Clock Source The following table specifies the source that generates for the SSI baud clock: <table border="1"> <thead> <tr> <th>Value</th> <th>Description</th> </tr> </thead> <tbody> <tr> <td>0x0</td> <td>System clock (based on clock source and divisor factor)</td> </tr> <tr> <td>0x1-0x4</td> <td>reserved</td> </tr> <tr> <td>0x5</td> <td>PIOSC</td> </tr> <tr> <td>0x6 - 0xF</td> <td>Reserved</td> </tr> </tbody> </table>	Value	Description	0x0	System clock (based on clock source and divisor factor)	0x1-0x4	reserved	0x5	PIOSC	0x6 - 0xF	Reserved
Value	Description													
0x0	System clock (based on clock source and divisor factor)													
0x1-0x4	reserved													
0x5	PIOSC													
0x6 - 0xF	Reserved													

Register 12: SSI Peripheral Identification 4 (SSIPeriphID4), offset 0xFD0

The **SSIPeriphIDn** registers are hard-coded and the fields within the register determine the reset value.

SSI Peripheral Identification 4 (SSIPeriphID4)

SSI0 base: 0x4000.8000
 SSI1 base: 0x4000.9000
 SSI2 base: 0x4000.A000
 SSI3 base: 0x4000.B000
 Offset 0xFD0
 Type RO, reset 0x0000.0000

	31	30	29	28	27	26	25	24	23	22	21	20	19	18	17	16
	reserved															
Type	RO	RO	RO	RO	RO	RO	RO	RO	RO	RO	RO	RO	RO	RO	RO	RO
Reset	0	0	0	0	0	0	0	0	0	0	0	0	0	0	0	0
	15	14	13	12	11	10	9	8	7	6	5	4	3	2	1	0
	reserved								PID4							
Type	RO	RO	RO	RO	RO	RO	RO	RO	RO	RO	RO	RO	RO	RO	RO	RO
Reset	0	0	0	0	0	0	0	0	0	0	0	0	0	0	0	0

Bit/Field	Name	Type	Reset	Description
31:8	reserved	RO	0x0000.00	Software should not rely on the value of a reserved bit. To provide compatibility with future products, the value of a reserved bit should be preserved across a read-modify-write operation.
7:0	PID4	RO	0x00	SSI Peripheral ID Register [7:0] Can be used by software to identify the presence of this peripheral.

Register 13: SSI Peripheral Identification 5 (SSIPeriphID5), offset 0xFD4

The **SSIPeriphIDn** registers are hard-coded and the fields within the register determine the reset value.

SSI Peripheral Identification 5 (SSIPeriphID5)

SSI0 base: 0x4000.8000
 SSI1 base: 0x4000.9000
 SSI2 base: 0x4000.A000
 SSI3 base: 0x4000.B000
 Offset 0xFD4
 Type RO, reset 0x0000.0000

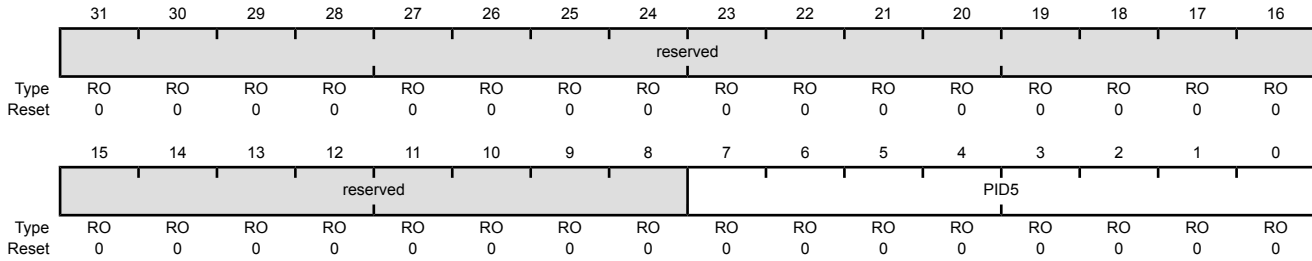

Bit/Field	Name	Type	Reset	Description
31:8	reserved	RO	0x0000.00	Software should not rely on the value of a reserved bit. To provide compatibility with future products, the value of a reserved bit should be preserved across a read-modify-write operation.
7:0	PID5	RO	0x00	SSI Peripheral ID Register [15:8] Can be used by software to identify the presence of this peripheral.

Register 14: SSI Peripheral Identification 6 (SSIPeriphID6), offset 0xFD8

The **SSIPeriphIDn** registers are hard-coded and the fields within the register determine the reset value.

SSI Peripheral Identification 6 (SSIPeriphID6)

SSI0 base: 0x4000.8000
 SSI1 base: 0x4000.9000
 SSI2 base: 0x4000.A000
 SSI3 base: 0x4000.B000
 Offset 0xFD8
 Type RO, reset 0x0000.0000

	31	30	29	28	27	26	25	24	23	22	21	20	19	18	17	16
	reserved															
Type	RO	RO	RO	RO	RO	RO	RO	RO	RO	RO	RO	RO	RO	RO	RO	RO
Reset	0	0	0	0	0	0	0	0	0	0	0	0	0	0	0	0
	15	14	13	12	11	10	9	8	7	6	5	4	3	2	1	0
	reserved								PID6							
Type	RO	RO	RO	RO	RO	RO	RO	RO	RO	RO	RO	RO	RO	RO	RO	RO
Reset	0	0	0	0	0	0	0	0	0	0	0	0	0	0	0	0

Bit/Field	Name	Type	Reset	Description
31:8	reserved	RO	0x0000.00	Software should not rely on the value of a reserved bit. To provide compatibility with future products, the value of a reserved bit should be preserved across a read-modify-write operation.
7:0	PID6	RO	0x00	SSI Peripheral ID Register [23:16] Can be used by software to identify the presence of this peripheral.

Register 15: SSI Peripheral Identification 7 (SSIPeriphID7), offset 0xFDC

The **SSIPeriphIDn** registers are hard-coded and the fields within the register determine the reset value.

SSI Peripheral Identification 7 (SSIPeriphID7)

SSI0 base: 0x4000.8000
 SSI1 base: 0x4000.9000
 SSI2 base: 0x4000.A000
 SSI3 base: 0x4000.B000
 Offset 0xFDC
 Type RO, reset 0x0000.0000

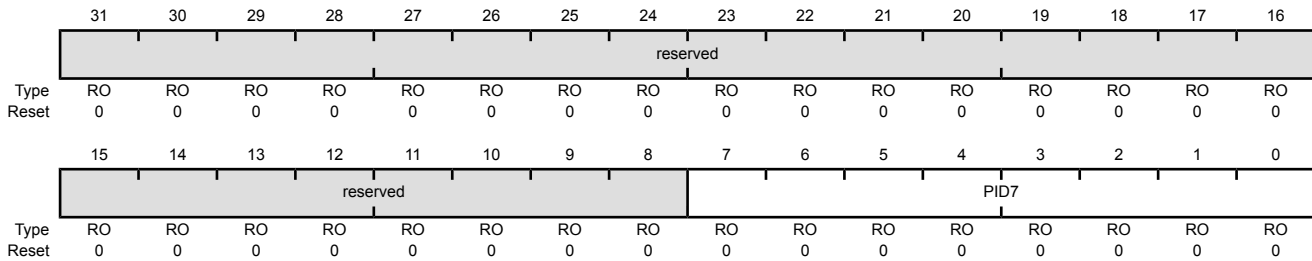

Bit/Field	Name	Type	Reset	Description
31:8	reserved	RO	0x0000.00	Software should not rely on the value of a reserved bit. To provide compatibility with future products, the value of a reserved bit should be preserved across a read-modify-write operation.
7:0	PID7	RO	0x00	SSI Peripheral ID Register [31:24] Can be used by software to identify the presence of this peripheral.

Register 16: SSI Peripheral Identification 0 (SSIPeriphID0), offset 0xFE0

The **SSIPeriphIDn** registers are hard-coded and the fields within the register determine the reset value.

SSI Peripheral Identification 0 (SSIPeriphID0)

SSI0 base: 0x4000.8000
 SSI1 base: 0x4000.9000
 SSI2 base: 0x4000.A000
 SSI3 base: 0x4000.B000
 Offset 0xFE0
 Type RO, reset 0x0000.0022

	31	30	29	28	27	26	25	24	23	22	21	20	19	18	17	16
	reserved															
Type	RO	RO	RO	RO	RO	RO	RO	RO	RO	RO	RO	RO	RO	RO	RO	RO
Reset	0	0	0	0	0	0	0	0	0	0	0	0	0	0	0	0
	15	14	13	12	11	10	9	8	7	6	5	4	3	2	1	0
	reserved								PID0							
Type	RO	RO	RO	RO	RO	RO	RO	RO	RO	RO	RO	RO	RO	RO	RO	RO
Reset	0	0	0	0	0	0	0	0	0	0	1	0	0	0	1	0

Bit/Field	Name	Type	Reset	Description
31:8	reserved	RO	0x0000.00	Software should not rely on the value of a reserved bit. To provide compatibility with future products, the value of a reserved bit should be preserved across a read-modify-write operation.
7:0	PID0	RO	0x22	SSI Peripheral ID Register [7:0] Can be used by software to identify the presence of this peripheral.

Register 17: SSI Peripheral Identification 1 (SSIPeriphID1), offset 0xFE4

The **SSIPeriphIDn** registers are hard-coded and the fields within the register determine the reset value.

SSI Peripheral Identification 1 (SSIPeriphID1)

SSI0 base: 0x4000.8000
 SSI1 base: 0x4000.9000
 SSI2 base: 0x4000.A000
 SSI3 base: 0x4000.B000
 Offset 0xFE4
 Type RO, reset 0x0000.0000

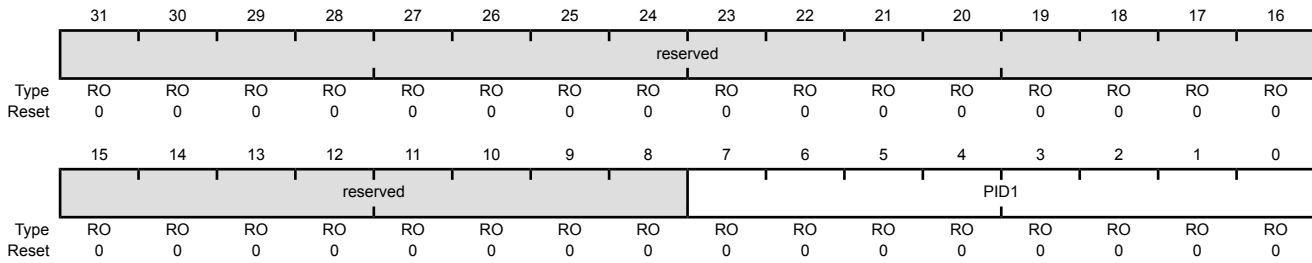

Bit/Field	Name	Type	Reset	Description
31:8	reserved	RO	0x0000.00	Software should not rely on the value of a reserved bit. To provide compatibility with future products, the value of a reserved bit should be preserved across a read-modify-write operation.
7:0	PID1	RO	0x00	SSI Peripheral ID Register [15:8] Can be used by software to identify the presence of this peripheral.

Register 18: SSI Peripheral Identification 2 (SSIPeriphID2), offset 0xFE8

The **SSIPeriphIDn** registers are hard-coded and the fields within the register determine the reset value.

SSI Peripheral Identification 2 (SSIPeriphID2)

SSI0 base: 0x4000.8000
 SSI1 base: 0x4000.9000
 SSI2 base: 0x4000.A000
 SSI3 base: 0x4000.B000
 Offset 0xFE8
 Type RO, reset 0x0000.0018

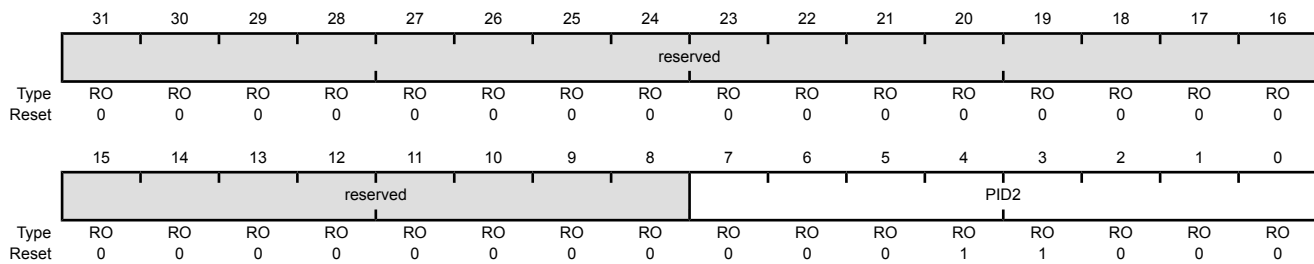

Bit/Field	Name	Type	Reset	Description
31:8	reserved	RO	0x0000.00	Software should not rely on the value of a reserved bit. To provide compatibility with future products, the value of a reserved bit should be preserved across a read-modify-write operation.
7:0	PID2	RO	0x18	SSI Peripheral ID Register [23:16] Can be used by software to identify the presence of this peripheral.

Register 19: SSI Peripheral Identification 3 (SSIPeriphID3), offset 0xFEC

The **SSIPeriphIDn** registers are hard-coded and the fields within the register determine the reset value.

SSI Peripheral Identification 3 (SSIPeriphID3)

SSI0 base: 0x4000.8000
 SSI1 base: 0x4000.9000
 SSI2 base: 0x4000.A000
 SSI3 base: 0x4000.B000
 Offset 0xFEC
 Type RO, reset 0x0000.0001

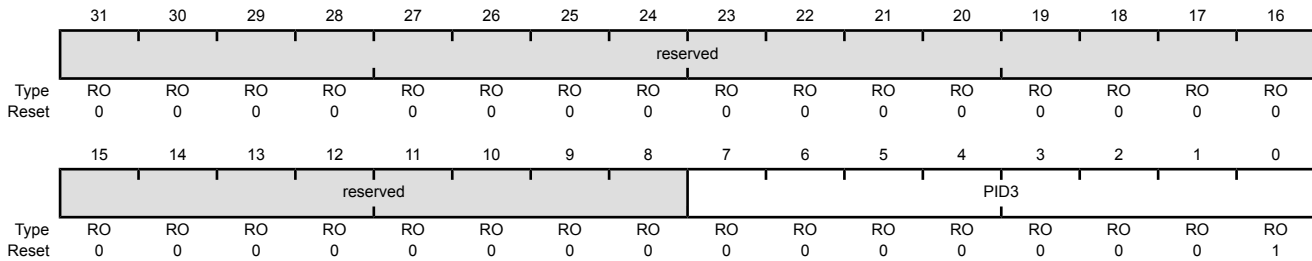

Bit/Field	Name	Type	Reset	Description
31:8	reserved	RO	0x0000.00	Software should not rely on the value of a reserved bit. To provide compatibility with future products, the value of a reserved bit should be preserved across a read-modify-write operation.
7:0	PID3	RO	0x01	SSI Peripheral ID Register [31:24] Can be used by software to identify the presence of this peripheral.

Register 20: SSI PrimeCell Identification 0 (SSIPCellID0), offset 0xFF0

The **SSIPCellIDn** registers are hard-coded, and the fields within the register determine the reset value.

SSI PrimeCell Identification 0 (SSIPCellID0)

SSI0 base: 0x4000.8000
 SSI1 base: 0x4000.9000
 SSI2 base: 0x4000.A000
 SSI3 base: 0x4000.B000
 Offset 0xFF0
 Type RO, reset 0x0000.000D

	31	30	29	28	27	26	25	24	23	22	21	20	19	18	17	16
	reserved															
Type	RO	RO	RO	RO	RO	RO	RO	RO	RO	RO	RO	RO	RO	RO	RO	RO
Reset	0	0	0	0	0	0	0	0	0	0	0	0	0	0	0	0
	15	14	13	12	11	10	9	8	7	6	5	4	3	2	1	0
	reserved								CID0							
Type	RO	RO	RO	RO	RO	RO	RO	RO	RO	RO	RO	RO	RO	RO	RO	RO
Reset	0	0	0	0	0	0	0	0	0	0	0	0	1	1	0	1

Bit/Field	Name	Type	Reset	Description
31:8	reserved	RO	0x0000.00	Software should not rely on the value of a reserved bit. To provide compatibility with future products, the value of a reserved bit should be preserved across a read-modify-write operation.
7:0	CID0	RO	0x0D	SSI PrimeCell ID Register [7:0] Provides software a standard cross-peripheral identification system.

Register 21: SSI PrimeCell Identification 1 (SSIPCellID1), offset 0xFF4

The **SSIPCellIDn** registers are hard-coded, and the fields within the register determine the reset value.

SSI PrimeCell Identification 1 (SSIPCellID1)

SSI0 base: 0x4000.8000
 SSI1 base: 0x4000.9000
 SSI2 base: 0x4000.A000
 SSI3 base: 0x4000.B000
 Offset 0xFF4
 Type RO, reset 0x0000.00F0

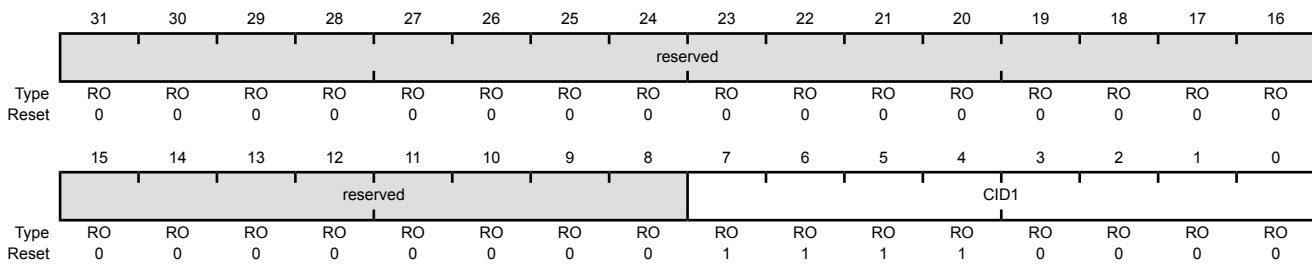

Bit/Field	Name	Type	Reset	Description
31:8	reserved	RO	0x0000.00	Software should not rely on the value of a reserved bit. To provide compatibility with future products, the value of a reserved bit should be preserved across a read-modify-write operation.
7:0	CID1	RO	0xF0	SSI PrimeCell ID Register [15:8] Provides software a standard cross-peripheral identification system.

Register 22: SSI PrimeCell Identification 2 (SSIPCellID2), offset 0xFF8

The **SSIPCellIDn** registers are hard-coded, and the fields within the register determine the reset value.

SSI PrimeCell Identification 2 (SSIPCellID2)

SSI0 base: 0x4000.8000
 SSI1 base: 0x4000.9000
 SSI2 base: 0x4000.A000
 SSI3 base: 0x4000.B000
 Offset 0xFF8
 Type RO, reset 0x0000.0005

	31	30	29	28	27	26	25	24	23	22	21	20	19	18	17	16
	reserved															
Type	RO	RO	RO	RO	RO	RO	RO	RO	RO	RO	RO	RO	RO	RO	RO	RO
Reset	0	0	0	0	0	0	0	0	0	0	0	0	0	0	0	0
	15	14	13	12	11	10	9	8	7	6	5	4	3	2	1	0
	reserved								CID2							
Type	RO	RO	RO	RO	RO	RO	RO	RO	RO	RO	RO	RO	RO	RO	RO	RO
Reset	0	0	0	0	0	0	0	0	0	0	0	0	0	1	0	1

Bit/Field	Name	Type	Reset	Description
31:8	reserved	RO	0x0000.00	Software should not rely on the value of a reserved bit. To provide compatibility with future products, the value of a reserved bit should be preserved across a read-modify-write operation.
7:0	CID2	RO	0x05	SSI PrimeCell ID Register [23:16] Provides software a standard cross-peripheral identification system.

Register 23: SSI PrimeCell Identification 3 (SSIPCellID3), offset 0xFFC

The **SSIPCellIDn** registers are hard-coded, and the fields within the register determine the reset value.

SSI PrimeCell Identification 3 (SSIPCellID3)

SSI0 base: 0x4000.8000
 SSI1 base: 0x4000.9000
 SSI2 base: 0x4000.A000
 SSI3 base: 0x4000.B000
 Offset 0xFFC
 Type RO, reset 0x0000.00B1

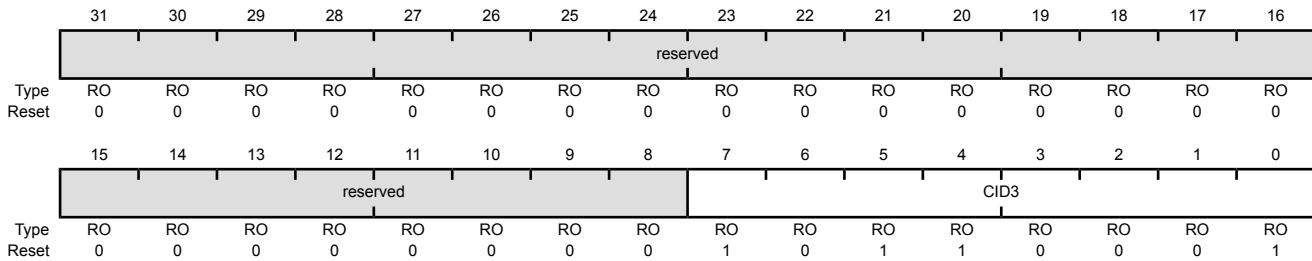

Bit/Field	Name	Type	Reset	Description
31:8	reserved	RO	0x0000.00	Software should not rely on the value of a reserved bit. To provide compatibility with future products, the value of a reserved bit should be preserved across a read-modify-write operation.
7:0	CID3	RO	0xB1	SSI PrimeCell ID Register [31:24] Provides software a standard cross-peripheral identification system.

15 Inter-Integrated Circuit (I²C) Interface

The Inter-Integrated Circuit (I²C) bus provides bi-directional data transfer through a two-wire design (a serial data line SDA and a serial clock line SCL), and interfaces to external I²C devices such as serial memory (RAMs and ROMs), networking devices, LCDs, tone generators, and so on. The I²C bus may also be used for system testing and diagnostic purposes in product development and manufacture. The LM4F231H5QR microcontroller includes providing the ability to interact (both transmit and receive) with other I²C devices on the bus.

The Stellaris® LM4F231H5QR controller includes I²C modules with the following features:

- Devices on the I²C bus can be designated as either a master or a slave
 - Supports both transmitting and receiving data as either a master or a slave
 - Supports simultaneous master and slave operation
- Four I²C modes
 - Master transmit
 - Master receive
 - Slave transmit
 - Slave receive
- Four transmission speeds:
 - Standard (100 Kbps)
 - Fast-mode (400 Kbps)
 - Fast-mode plus (1 Mbps)
 - High-speed mode (3.33 Mbps)
- Clock low timeout interrupt
- Dual slave address capability
- Clock low timeout interrupt
- Dual slave address capability
- Master and slave interrupt generation
 - Master generates interrupts when a transmit or receive operation completes (or aborts due to an error)
 - Slave generates interrupts when data has been transferred or requested by a master or when a START or STOP condition is detected
- Master with arbitration and clock synchronization, multimaster support, and 7-bit addressing mode

15.1 Block Diagram

Figure 15-1. I²C Block Diagram

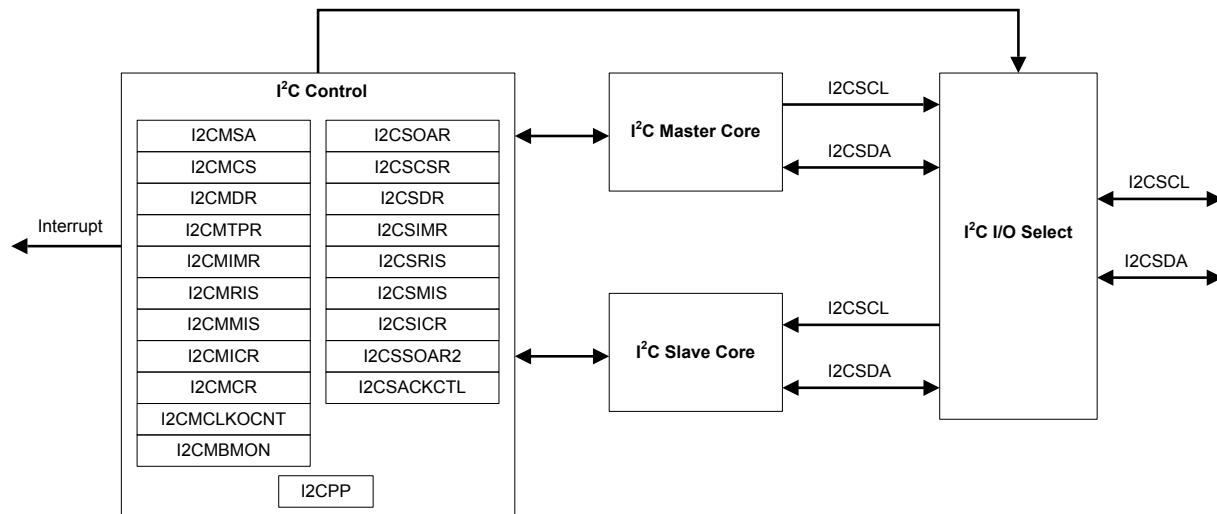

15.2 Signal Description

The following table lists the external signals of the I²C interface and describes the function of each. The I²C interface signals are alternate functions for some GPIO signals and default to be GPIO signals at reset, with the exception of the I2C0SCL and I2CSDA pins which default to the I²C function. The column in the table below titled "Pin Mux/Pin Assignment" lists the possible GPIO pin placements for the I²C signals. The **AFSEL** bit in the **GPIO Alternate Function Select (GPIOAFSEL)** register (page 644) should be set to choose the I²C function. The number in parentheses is the encoding that must be programmed into the **PMC_n** field in the **GPIO Port Control (GPIOPTCL)** register (page 661) to assign the I²C signal to the specified GPIO port pin. Note that the I2CSCL pin should be set to open drain using the **GPIO Open Drain Select (GPIOODR)** register. For more information on configuring GPIOs, see "General-Purpose Input/Outputs (GPIOs)" on page 623.

Table 15-1. I2C Signals (64LQFP)

Pin Name	Pin Number	Pin Mux / Pin Assignment	Pin Type	Buffer Type ^a	Description
I2C0SCL	47	PB2 (3)	I/O	OD	I ² C module 0 clock. Note that this signal has an active pull-up. The corresponding port pin should not be configured as open drain.
I2C0SDA	48	PB3 (3)	I/O	OD	I ² C module 0 data.
I2C1SCL	23 33	PA6 (3) PG4 (3)	I/O	OD	I ² C module 1 clock. Note that this signal has an active pull-up. The corresponding port pin should not be configured as open drain.
I2C1SDA	24 32	PA7 (3) PG5 (3)	I/O	OD	I ² C module 1 data.
I2C2SCL	59	PE4 (3)	I/O	OD	I ² C module 2 clock. Note that this signal has an active pull-up. The corresponding port pin should not be configured as open drain.
I2C2SDA	60	PE5 (3)	I/O	OD	I ² C module 2 data.

Table 15-1. I²C Signals (64LQFP) (continued)

Pin Name	Pin Number	Pin Mux / Pin Assignment	Pin Type	Buffer Type ^a	Description
I2C3SCL	37 61	PG0 (3) PD0 (3)	I/O	OD	I ² C module 3 clock. Note that this signal has an active pull-up. The corresponding port pin should not be configured as open drain.
I2C3SDA	36 62	PG1 (3) PD1 (3)	I/O	OD	I ² C module 3 data.
I2C4SCL	35	PG2 (3)	I/O	OD	I ² C module 4 clock. Note that this signal has an active pull-up. The corresponding port pin should not be configured as open drain.
I2C4SDA	34	PG3 (3)	I/O	OD	I ² C module 4 data.
I2C5SCL	1	PB6 (3)	I/O	OD	I ² C module 5 clock. Note that this signal has an active pull-up. The corresponding port pin should not be configured as open drain.
I2C5SDA	4	PB7 (3)	I/O	OD	I ² C module 5 data.

a. The TTL designation indicates the pin has TTL-compatible voltage levels.

15.3 Functional Description

Each I²C module is comprised of both master and slave functions. For proper operation, the SDA pin must be configured as an open-drain signal. Due to the internal circuitry that supports high-speed operation, the SCL pin must not be configured as an open-drain signal, although the internal circuitry causes it to act as if it were an open drain signal. A typical I²C bus configuration is shown in Figure 15-2. Refer to the *I²C-bus specification and user manual* to determine the size of the pull-ups needed for proper operation.

See “Inter-Integrated Circuit (I²C) Interface” on page 1339 for I²C timing diagrams.

Figure 15-2. I²C Bus Configuration

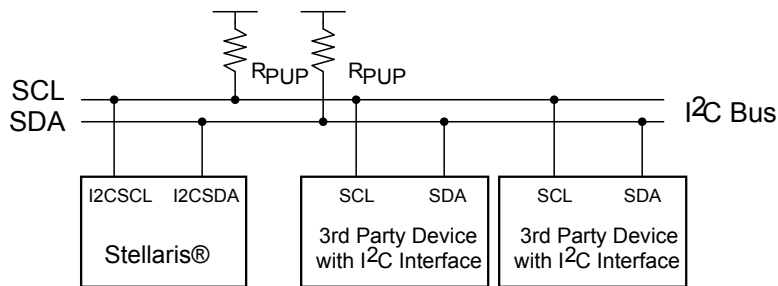

15.3.1 I²C Bus Functional Overview

The I²C bus uses only two signals: SDA and SCL, named I2CSDA and I2CSCL on Stellaris microcontrollers. SDA is the bi-directional serial data line and SCL is the bi-directional serial clock line. The bus is considered idle when both lines are High.

Every transaction on the I²C bus is nine bits long, consisting of eight data bits and a single acknowledge bit. The number of bytes per transfer (defined as the time between a valid START and STOP condition, described in “START and STOP Conditions” on page 964) is unrestricted, but each byte has to be followed by an acknowledge bit, and data must be transferred MSB first. When a receiver cannot receive another complete byte, it can hold the clock line SCL Low and force the transmitter into a wait state. The data transfer continues when the receiver releases the clock SCL.

15.3.1.1 START and STOP Conditions

The protocol of the I²C bus defines two states to begin and end a transaction: START and STOP. A High-to-Low transition on the SDA line while the SCL is High is defined as a START condition, and a Low-to-High transition on the SDA line while SCL is High is defined as a STOP condition. The bus is considered busy after a START condition and free after a STOP condition. See Figure 15-3.

Figure 15-3. START and STOP Conditions

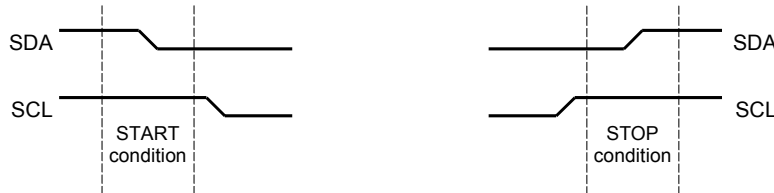

The STOP bit determines if the cycle stops at the end of the data cycle or continues on to a repeated START condition. To generate a single transmit cycle, the **I²C Master Slave Address (I2CMSA)** register is written with the desired address, the R/S bit is cleared, and the Control register is written with ACK=X (0 or 1), STOP=1, START=1, and RUN=1 to perform the operation and stop. When the operation is completed (or aborted due to an error), the interrupt pin becomes active and the data may be read from the **I²C Master Data (I2CMDR)** register. When the I²C module operates in Master receiver mode, the ACK bit is normally set causing the I²C bus controller to transmit an acknowledge automatically after each byte. This bit must be cleared when the I²C bus controller requires no further data to be transmitted from the slave transmitter.

When operating in slave mode, two bits in the **I²C Slave Raw Interrupt Status (I2CSRIS)** register indicate detection of start and stop conditions on the bus; while two bits in the **I²C Slave Masked Interrupt Status (I2CSMIS)** register allow start and stop conditions to be promoted to controller interrupts (when interrupts are enabled).

15.3.1.2 Data Format with 7-Bit Address

Data transfers follow the format shown in Figure 15-4. After the START condition, a slave address is transmitted. This address is 7-bits long followed by an eighth bit, which is a data direction bit (R/S bit in the **I2CMSA** register). If the R/S bit is clear, it indicates a transmit operation (send), and if it is set, it indicates a request for data (receive). A data transfer is always terminated by a STOP condition generated by the master, however, a master can initiate communications with another device on the bus by generating a repeated START condition and addressing another slave without first generating a STOP condition. Various combinations of receive/transmit formats are then possible within a single transfer.

Figure 15-4. Complete Data Transfer with a 7-Bit Address

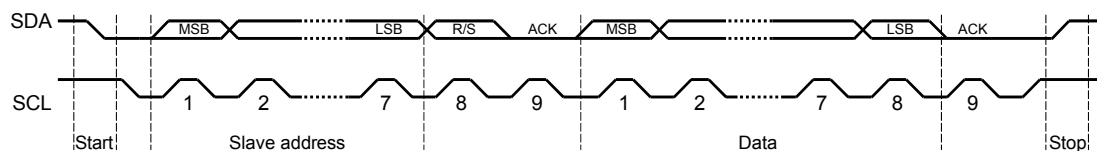

The first seven bits of the first byte make up the slave address (see Figure 15-5). The eighth bit determines the direction of the message. A zero in the R/S position of the first byte means that the

master transmits (sends) data to the selected slave, and a one in this position means that the master receives data from the slave.

Figure 15-5. R/S Bit in First Byte

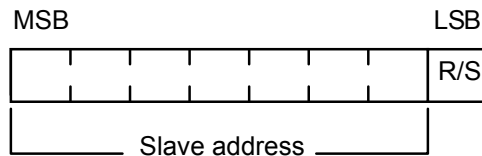

15.3.1.3 Data Validity

The data on the SDA line must be stable during the high period of the clock, and the data line can only change when SCL is Low (see Figure 15-6).

Figure 15-6. Data Validity During Bit Transfer on the I²C Bus

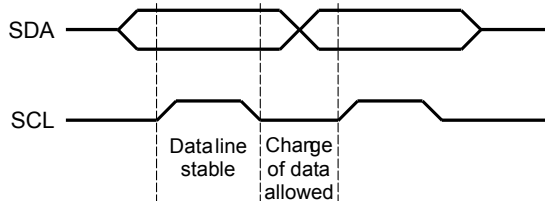

15.3.1.4 Acknowledge

All bus transactions have a required acknowledge clock cycle that is generated by the master. During the acknowledge cycle, the transmitter (which can be the master or slave) releases the SDA line. To acknowledge the transaction, the receiver must pull down SDA during the acknowledge clock cycle. The data transmitted out by the receiver during the acknowledge cycle must comply with the data validity requirements described in “Data Validity” on page 965.

When a slave receiver does not acknowledge the slave address, SDA must be left High by the slave so that the master can generate a STOP condition and abort the current transfer. If the master device is acting as a receiver during a transfer, it is responsible for acknowledging each transfer made by the slave. Because the master controls the number of bytes in the transfer, it signals the end of data to the slave transmitter by not generating an acknowledge on the last data byte. The slave transmitter must then release SDA to allow the master to generate the STOP or a repeated START condition.

If the slave is required to provide a manual ACK or NACK, the **I²C Slave ACK Control (I2CSACKCTL)** register allows the slave to NACK for invalid data or command or ACK for valid data or command. When this operation is enabled, the I²C clock is pulled low after the last data bit until this register is written with the indicated response.

15.3.1.5 Clock Low Timeout

The I²C slave can extend the transaction by pulling the clock low periodically to create a slow bit transfer rate. The I²C module has a 12-bit programmable counter that is used to track how long the clock has been held low. The upper 8 bits of the count value are software programmable through the **I²C Master Clock Low Timeout Count (I2CMCLKOCNT)** register. Application can program the 8 most significant bits of the counter to reflect the acceptable cumulative low period in transaction. The count is loaded at the START condition and counts down on each falling edge of the internal

bus clock of the master. Note that the internal bus clock generated for this counter keeps running at the programmed I²C speed even if the SCL is held low on the bus. Upon reaching terminal count, the master state machine forces Abort on the bus by issuing a STOP condition at the instance of SCL and SDA release.

As an example, if an I²C module was operating at 100 kHz speed, programming the **I2CMCLKOCNT** register to 0xDA would result in a cumulative clock low period of 34.88 ms.

The **CLKRIS** bit in the **I²C Master Raw Interrupt Status (I2CMRIS)** register is set when the clock timeout period is reached, allowing the master to start corrective action to resolve the remote slave state. In addition, the **CLKTO** bit in the **I²C Master Control/Status (I2CMCS)** register is set; this bit is cleared when a STOP condition is sent or during the I²C master reset.. The status of the raw SDA and SCL signals are readable by software through the **SDA** and **SCL** bits in the **I²C Master Bus Monitor (I2CMBMON)** register to help determine the state of the remote slave.

If the slave holds the clock low continuously, the only solution is to interrupt the processor using the **CLKRIS** bit and resolve the condition at higher protocol levels by resetting both the master and the remote slave.

15.3.1.6 Dual Address

The I²C interface supports dual address capability for the slave. The additional programmable address is provided and can be matched if enabled. In legacy mode with dual address disabled, the I²C slave provides an ACK on the bus if the address matches the **OAR** field in the **I2CSOAR** register. In dual address mode, the I²C slave provides an ACK on the bus if either the **OAR** field in the **I2CSOAR** register or the **OAR2** field in the **I2CSOAR2** register is matched. The enable for dual address is programmable through the **OAR2EN** bit in the **I2CSOAR2** register and there is no disable on the legacy address.

The **OAR2SEL** bit in the **I2CSCSR** register indicates if the address that was ACKed is the alternate address or not. When this bit is clear, it indicates either legacy operation or no address match.

15.3.1.7 Arbitration

A master may start a transfer only if the bus is idle. It's possible for two or more masters to generate a START condition within minimum hold time of the START condition. In these situations, an arbitration scheme takes place on the SDA line, while SCL is High. During arbitration, the first of the competing master devices to place a '1' (High) on SDA while another master transmits a '0' (Low) switches off its data output stage and retires until the bus is idle again.

Arbitration can take place over several bits. Its first stage is a comparison of address bits, and if both masters are trying to address the same device, arbitration continues on to the comparison of data bits.

15.3.1.8 High-Speed Operation

The Stellaris I²C peripheral has support for High-speed operation as both a master and slave. When operating as a master, the protocol is shown in Figure 15-7. The master is responsible for sending a master code byte in either Standard (100 Kbps) or Fast-mode (400 Kbps) before it begins transferring in High-speed mode. The master code byte must contain data in the form of 0000.1XXX and is used to tell the slave devices to prepare for a High-speed transfer. The master code byte should never be acknowledged by a slave since it is only used to indicate that the upcoming data is going to be transferred at a higher data rate. To send the master code byte, software should place the value of the master code byte into the **I2CMSA** register and write the **I2CMCS** register with a value of 0x11. This places the I²C master peripheral in High-speed mode, and all subsequent transfers (until STOP) are carried out at High-speed data rate using the normal **I2CMCS** command

bits, without setting the HS bit in the I2CMCS register. Again, setting the HS bit in the I2CMCS register is only necessary during the master code byte.

When operating as a High-speed slave, there is no additional software required.

Figure 15-7. High-Speed Data Format

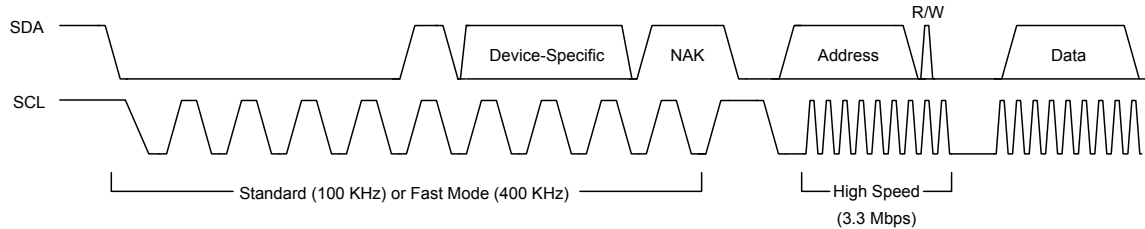

Note: High-Speed mode is 3.4 Mbps, provided correct system clock frequency is set and there is appropriate pull strength on SCL and SDA lines.

15.3.2 Available Speed Modes

The I²C bus can run in Standard mode (100 kbps), Fast mode (400 kbps), Fast mode plus (1 Mbps) or High-Speed mode (3.33 Mbps). The selected mode should match the speed of the other I²C devices on the bus.

15.3.2.1 Standard, Fast, and Fast Plus Modes

Standard, Fast, and Fast Plus modes are selected using a value in the I²C Master Timer Period (I2CMTPR) register that results in an SCL frequency of 100 kbps for Standard mode, 400 kbps for Fast mode, or 1 Mbps for Fast mode plus.

The I²C clock rate is determined by the parameters *CLK_PRD*, *TIMER_PRD*, *SCL_LP*, and *SCL_HP* where:

CLK_PRD is the system clock period

SCL_LP is the low phase of SCL (fixed at 6)

SCL_HP is the high phase of SCL (fixed at 4)

TIMER_PRD is the programmed value in the I2CMTPR register (see page 988).

The I²C clock period is calculated as follows:

$$SCL_PERIOD = 2 \times (1 + TIMER_PRD) \times (SCL_LP + SCL_HP) \times CLK_PRD$$

For example:

$$CLK_PRD = 50 \text{ ns}$$

$$TIMER_PRD = 2$$

$$SCL_LP=6$$

$$SCL_HP=4$$

yields a SCL frequency of:

$$1/SCL_PERIOD = 333 \text{ Khz}$$

Table 15-2 gives examples of the timer periods that should be used to generate Standard, Fast mode, and Fast mode plus SCL frequencies based on various system clock frequencies.

Table 15-2. Examples of I²C Master Timer Period versus Speed Mode

System Clock	Timer Period	Standard Mode	Timer Period	Fast Mode	Timer Period	Fast Mode Plus
4 MHz	0x01	100 Kbps	-	-	-	-
6 MHz	0x02	100 Kbps	-	-	-	-
12.5 MHz	0x06	89 Kbps	0x01	312 Kbps	-	-
16.7 MHz	0x08	93 Kbps	0x02	278 Kbps	-	-
20 MHz	0x09	100 Kbps	0x02	333 Kbps	-	-
25 MHz	0x0C	96.2 Kbps	0x03	312 Kbps	-	-
33 MHz	0x10	97.1 Kbps	0x04	330 Kbps	-	-
40 MHz	0x13	100 Kbps	0x04	400 Kbps	0x01	1000 Kbps
50 MHz	0x18	100 Kbps	0x06	357 Kbps	0x02	833 Kbps
80 MHz	0x27	100 Kbps	0x09	400 Kbps	0x03	1000 Kbps

15.3.2.2 High-Speed Mode

High-Speed mode is configured by setting the HS bit in the I²C Master Control/Status (I2CMCS) register. High-Speed mode transmits data at a high bit rate with a 66.6%/33.3% duty cycle, but communication and arbitration are done at Standard, Fast mode, or Fast-mode plus speed, depending on which is selected by the user. When the HS bit in the I2CMCS register is set, current mode pull-ups are enabled.

The clock period can be selected using the equation above, but in this case, SCL_LP=2 and SCL_HP=1. So for example:

```
CLK_PRD = 25 ns
TIMER_PRD = 1
SCL_LP=2
SCL_HP=1
```

yields a SCL frequency of:

$$1/T = 3.33 \text{ Mhz}$$

Table 15-3 on page 968 gives examples of timer period and system clock in High-Speed mode.

Table 15-3. Examples of I²C Master Timer Period in High-Speed Mode

System Clock	Timer Period	Transmission Mode
40 MHz	0x01	3.33 Mbps
50 MHz	0x02	2.77 Mbps
80 MHz	0x03	3.33 Mbps

15.3.3 Interrupts

The I²C can generate interrupts when the following conditions are observed:

- Master transaction completed
- Master arbitration lost
- Master transaction error

- Master bus timeout
- Slave transaction received
- Slave transaction requested
- Stop condition on bus detected
- Start condition on bus detected

The I²C master and I²C slave modules have separate interrupt signals. While both modules can generate interrupts for multiple conditions, only a single interrupt signal is sent to the interrupt controller.

15.3.3.1 I²C Master Interrupts

The I²C master module generates an interrupt when a transaction completes (either transmit or receive), when arbitration is lost, or when an error occurs during a transaction. To enable the I²C master interrupt, software must set the `IM` bit in the **I²C Master Interrupt Mask (I2CMIMR)** register. When an interrupt condition is met, software must check the `ERROR` and `ARBLST` bits in the **I²C Master Control/Status (I2CMCS)** register to verify that an error didn't occur during the last transaction and to ensure that arbitration has not been lost. An error condition is asserted if the last transaction wasn't acknowledged by the slave. If an error is not detected and the master has not lost arbitration, the application can proceed with the transfer. The interrupt is cleared by writing a 1 to the `IC` bit in the **I²C Master Interrupt Clear (I2CMICR)** register.

If the application doesn't require the use of interrupts, the raw interrupt status is always visible via the **I²C Master Raw Interrupt Status (I2CMRIS)** register.

15.3.3.2 I²C Slave Interrupts

The slave module can generate an interrupt when data has been received or requested. This interrupt is enabled by setting the `DATAIM` bit in the **I²C Slave Interrupt Mask (I2CSIMR)** register. Software determines whether the module should write (transmit) or read (receive) data from the **I²C Slave Data (I2CSDR)** register, by checking the `RREQ` and `TREQ` bits of the **I²C Slave Control/Status (I2CSCR)** register. If the slave module is in receive mode and the first byte of a transfer is received, the `FBR` bit is set along with the `RREQ` bit. The interrupt is cleared by setting the `DATAIC` bit in the **I²C Slave Interrupt Clear (I2CSICR)** register.

In addition, the slave module can generate an interrupt when a start and stop condition is detected. These interrupts are enabled by setting the `STARTIM` and `STOPIM` bits of the **I²C Slave Interrupt Mask (I2CSIMR)** register and cleared by writing a 1 to the `STOPIC` and `STARTIC` bits of the **I²C Slave Interrupt Clear (I2CSICR)** register.

If the application doesn't require the use of interrupts, the raw interrupt status is always visible via the **I²C Slave Raw Interrupt Status (I2CSRIS)** register.

15.3.4 Loopback Operation

The I²C modules can be placed into an internal loopback mode for diagnostic or debug work by setting the `LPBK` bit in the **I²C Master Configuration (I2CMCR)** register. In loopback mode, the SDA and SCL signals from the master and slave modules are tied together.

15.3.5 Command Sequence Flow Charts

This section details the steps required to perform the various I²C transfer types in both master and slave mode.

15.3.5.1 I²C Master Command Sequences

The figures that follow show the command sequences available for the I²C master.

Figure 15-8. Master Single TRANSMIT

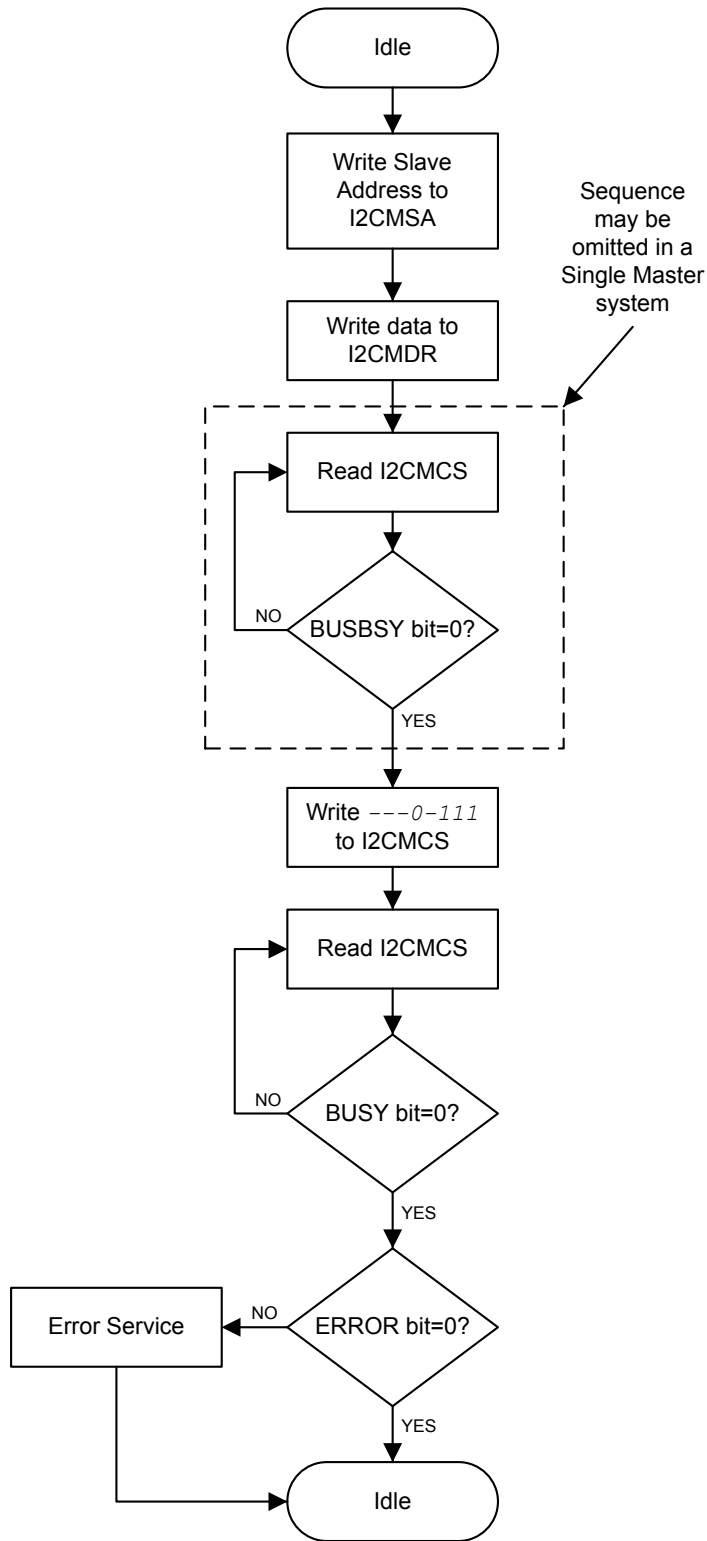

Figure 15-9. Master Single RECEIVE

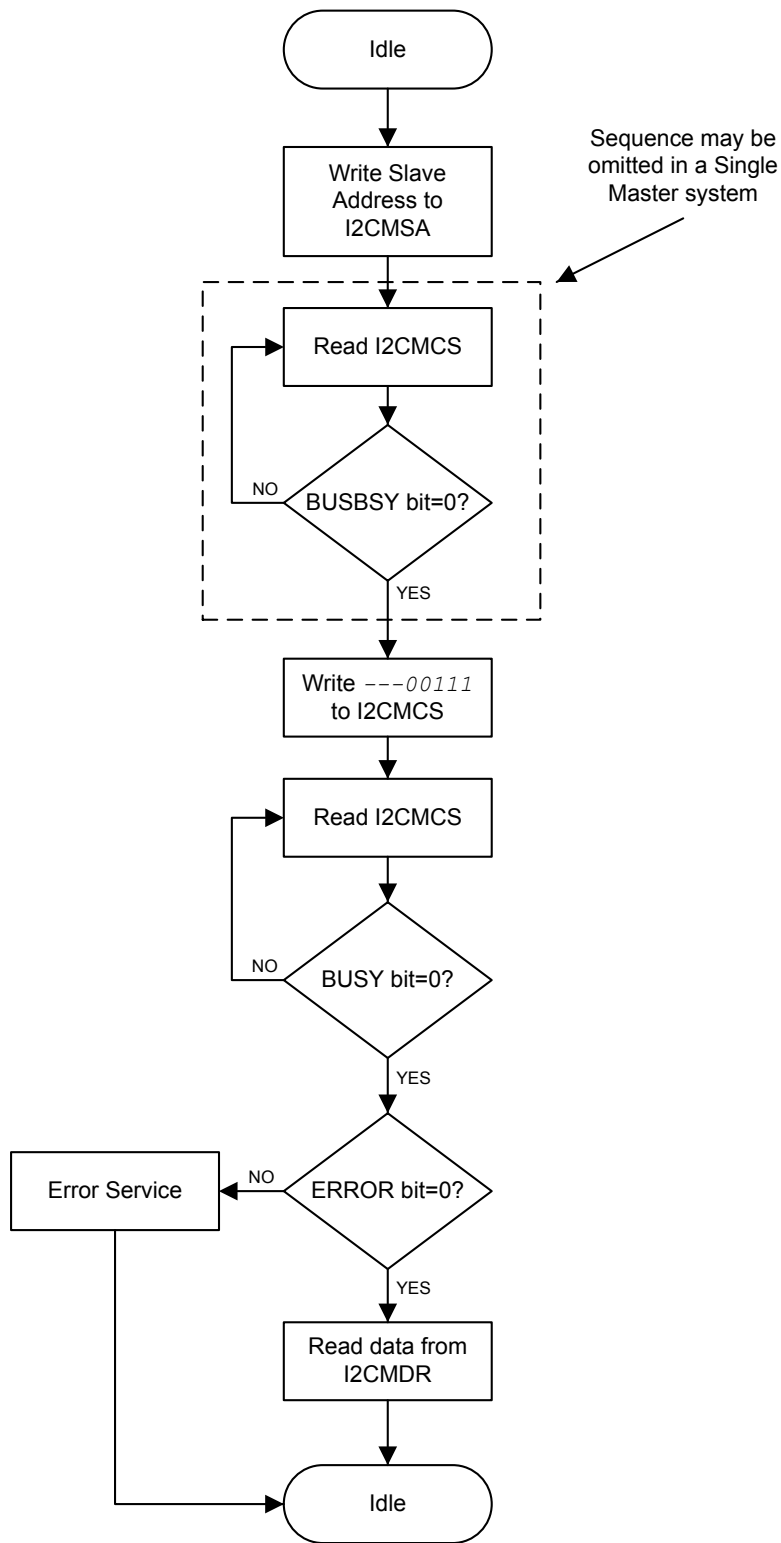

Figure 15-10. Master TRANSMIT with Repeated START

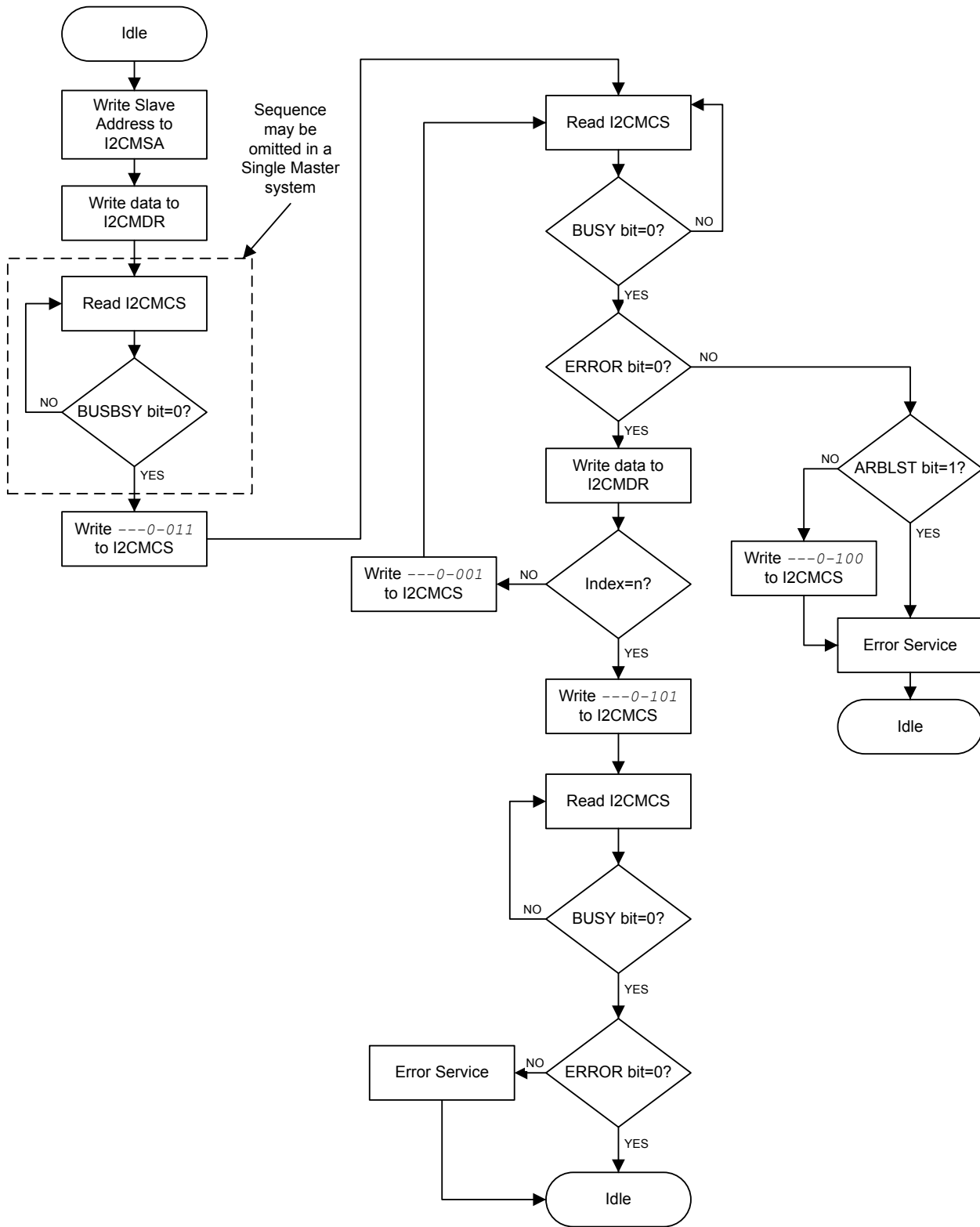

Figure 15-11. Master RECEIVE with Repeated START

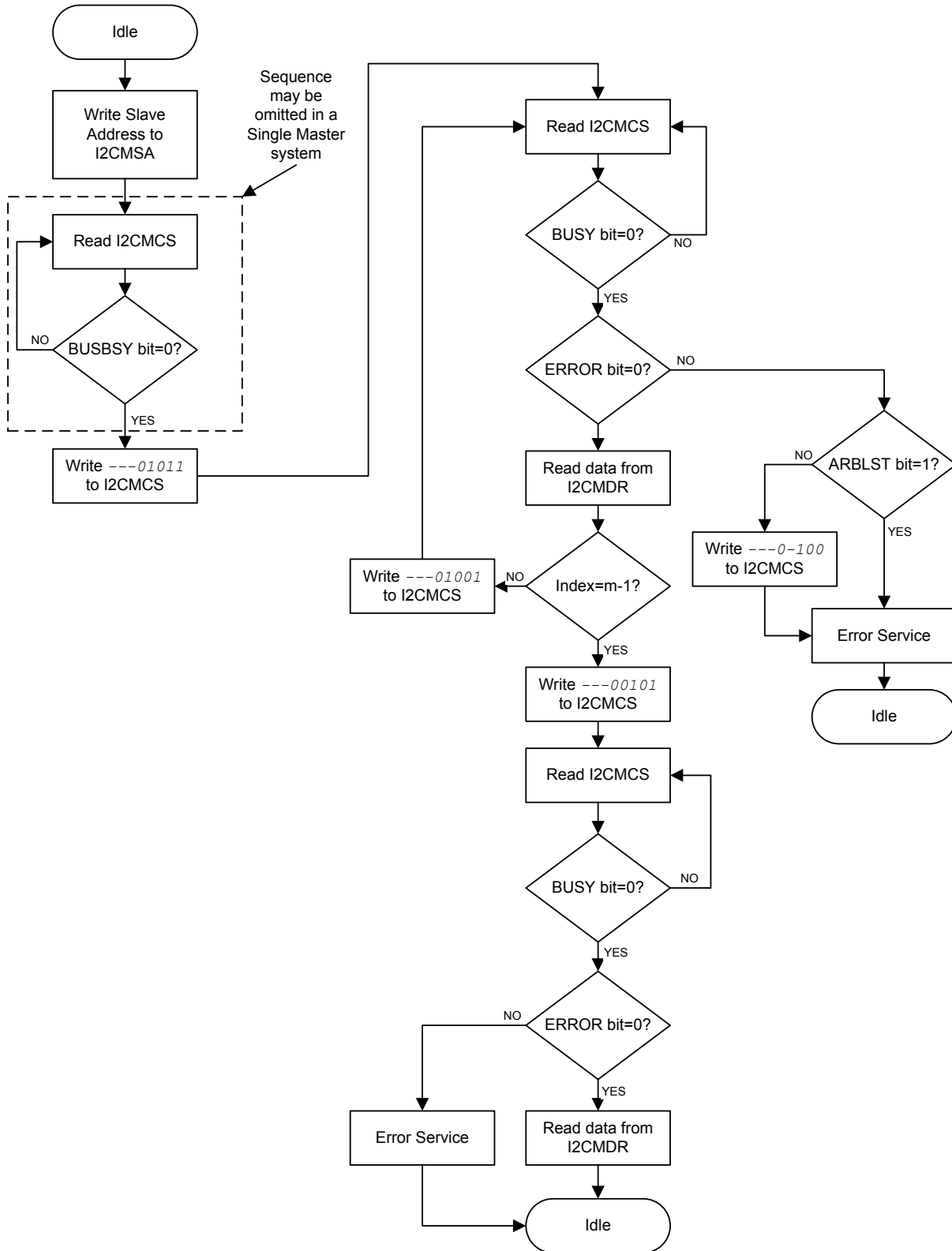

Figure 15-12. Master RECEIVE with Repeated START after TRANSMIT with Repeated START

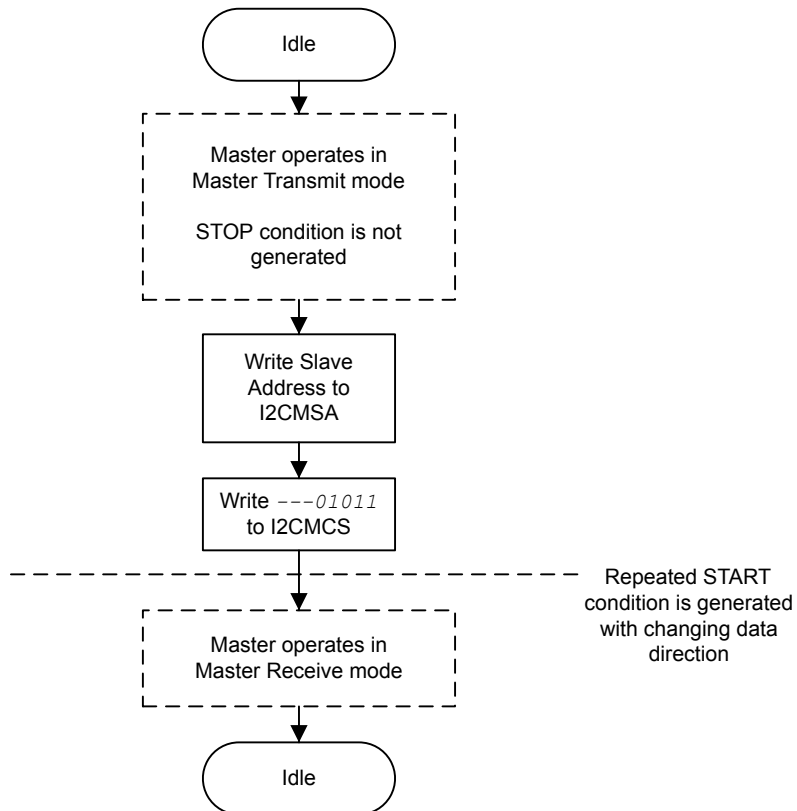

Figure 15-13. Master TRANSMIT with Repeated START after RECEIVE with Repeated START

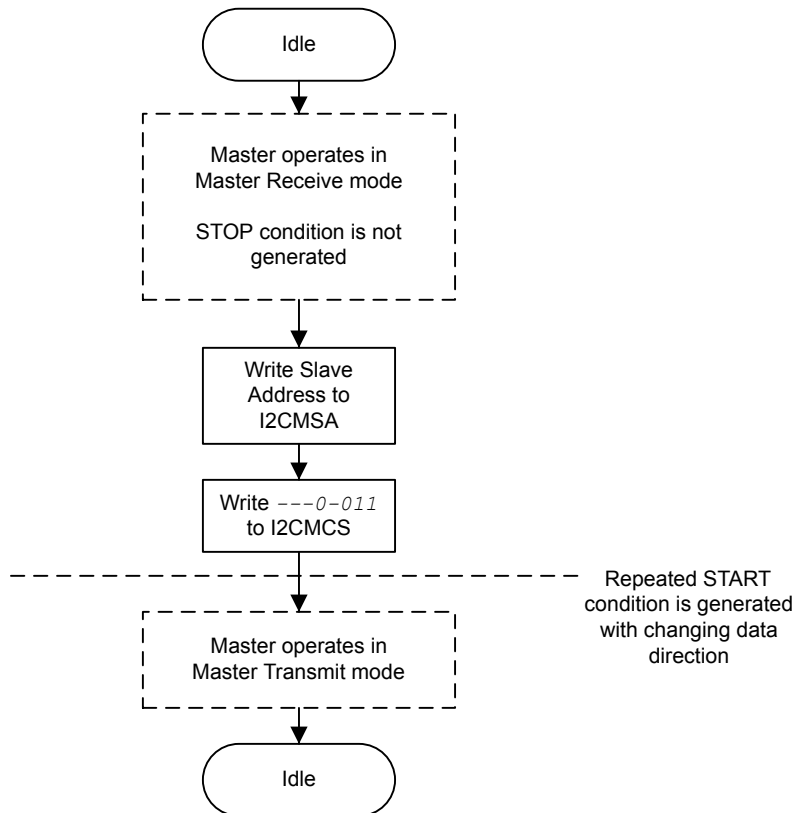
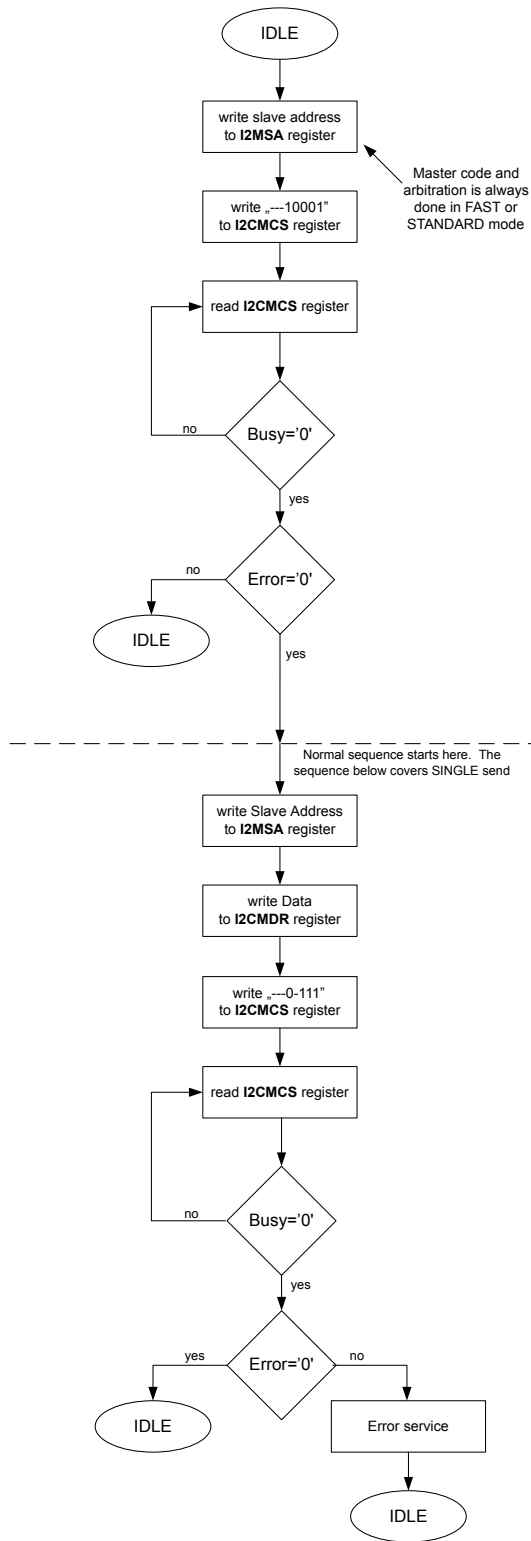

Figure 15-14. High Speed Mode Master Transmit



15.3.5.2 I²C Slave Command Sequences

Figure 15-15 on page 978 presents the command sequence available for the I²C slave.

Figure 15-15. Slave Command Sequence

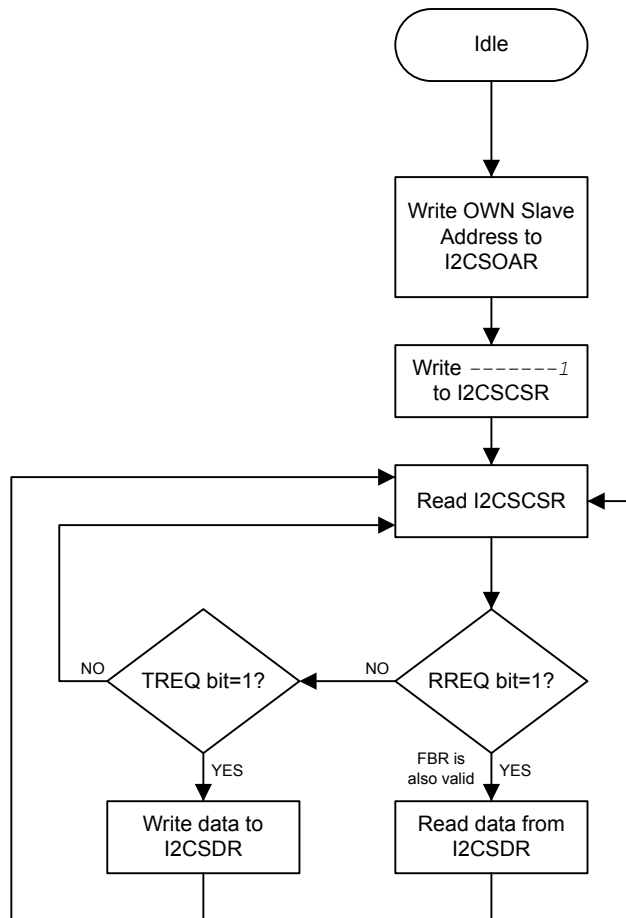

15.4 Initialization and Configuration

The following example shows how to configure the I²C module to transmit a single byte as a master. This assumes the system clock is 20 MHz.

1. Enable the I²C clock using the **RCGCI2C** register in the System Control module (see page 326).
2. Enable the clock to the appropriate GPIO module via the **RCGCGPIO** register in the System Control module (see page 319). To find out which GPIO port to enable, refer to Table 22-5 on page 1314.
3. In the GPIO module, enable the appropriate pins for their alternate function using the **GPIOAFSEL** register (see page 644). To determine which GPIOs to configure, see Table 22-4 on page 1307.
4. Enable the I2CSDA pin for open-drain operation. See page 649.

5. Configure the `PMCn` fields in the **GPIOPCTL** register to assign the I²C signals to the appropriate pins. See page 661 and Table 22-5 on page 1314.
6. Initialize the I²C Master by writing the **I2CMCR** register with a value of 0x0000.0010.
7. Set the desired SCL clock speed of 100 Kbps by writing the **I2CMTPR** register with the correct value. The value written to the **I2CMTPR** register represents the number of system clock periods in one SCL clock period. The TPR value is determined by the following equation:

$$\begin{aligned} \text{TPR} &= (\text{System Clock} / (2 * (\text{SCL_LP} + \text{SCL_HP}) * \text{SCL_CLK})) - 1; \\ \text{TPR} &= (20\text{MHz} / (2 * (6+4) * 100000)) - 1; \\ \text{TPR} &= 9 \end{aligned}$$

Write the **I2CMTPR** register with the value of 0x0000.0009.

8. Specify the slave address of the master and that the next operation is a Transmit by writing the **I2CMSA** register with a value of 0x0000.0076. This sets the slave address to 0x3B.
9. Place data (byte) to be transmitted in the data register by writing the **I2CMDR** register with the desired data.
10. Initiate a single byte transmit of the data from Master to Slave by writing the **I2CMCS** register with a value of 0x0000.0007 (STOP, START, RUN).
11. Wait until the transmission completes by polling the **I2CMCS** register's `BUSBSY` bit until it has been cleared.
12. Check the `ERROR` bit in the **I2CMCS** register to confirm the transmit was acknowledged.

15.5 Register Map

Table 15-4 on page 980 lists the I²C registers. All addresses given are relative to the I²C base address:

- I²C 0: 0x4002.0000
- I²C 1: 0x4002.1000
- I²C 2: 0x4002.2000
- I²C 3: 0x4002.3000
- I²C 4: 0x400C.0000
- I²C 5: 0x400C.1000

Note that the I²C module clock must be enabled before the registers can be programmed (see page 326). There must be a delay of 3 system clocks after the I²C module clock is enabled before any I²C module registers are accessed.

The `hw_i2c.h` file in the StellarisWare® Driver Library uses a base address of 0x800 for the I²C slave registers. Be aware when using registers with offsets between 0x800 and 0x818 that StellarisWare uses an offset between 0x000 and 0x018 with the slave base address.

Table 15-4. Inter-Integrated Circuit (I²C) Interface Register Map

Offset	Name	Type	Reset	Description	See page
I²C Master					
0x000	I2CMSA	R/W	0x0000.0000	I2C Master Slave Address	981
0x004	I2CMCS	R/W	0x0000.0020	I2C Master Control/Status	982
0x008	I2CMDR	R/W	0x0000.0000	I2C Master Data	987
0x00C	I2CMTPR	R/W	0x0000.0001	I2C Master Timer Period	988
0x010	I2CMIMR	R/W	0x0000.0000	I2C Master Interrupt Mask	989
0x014	I2CMRIS	RO	0x0000.0000	I2C Master Raw Interrupt Status	990
0x018	I2CMMIS	RO	0x0000.0000	I2C Master Masked Interrupt Status	991
0x01C	I2CMICR	WO	0x0000.0000	I2C Master Interrupt Clear	992
0x020	I2CMCR	R/W	0x0000.0000	I2C Master Configuration	993
0x024	I2CMCLKOCNT	R/W	0x0000.0000	I2C Master Clock Low Timeout Count	994
0x02C	I2CMBMON	RO	0x0000.0003	I2C Master Bus Monitor	995
I²C Slave					
0x800	I2CSOAR	R/W	0x0000.0000	I2C Slave Own Address	996
0x804	I2CSCSR	RO	0x0000.0000	I2C Slave Control/Status	997
0x808	I2CSDR	R/W	0x0000.0000	I2C Slave Data	999
0x80C	I2CSIMR	R/W	0x0000.0000	I2C Slave Interrupt Mask	1000
0x810	I2CSRIS	RO	0x0000.0000	I2C Slave Raw Interrupt Status	1001
0x814	I2CSMIS	RO	0x0000.0000	I2C Slave Masked Interrupt Status	1002
0x818	I2CSICR	WO	0x0000.0000	I2C Slave Interrupt Clear	1003
0x81C	I2CSOAR2	R/W	0x0000.0000	I2C Slave Own Address 2	1004
0x820	I2CSACKCTL	R/W	0x0000.0000	I2C Slave ACK Control	1005
I²C Status and Control					
0xFC0	I2CPP	RO	0x0000.0001	I2C Peripheral Properties	1006
0xFC4	I2CPC	RO	0x0000.0001	I2C Peripheral Configuration	1007

15.6 Register Descriptions (I²C Master)

The remainder of this section lists and describes the I²C master registers, in numerical order by address offset.

Register 1: I²C Master Slave Address (I2CMSA), offset 0x000

This register consists of eight bits: seven address bits (A6-A0), and a Receive/Send bit, which determines if the next operation is a Receive (High), or Transmit (Low).

I2C Master Slave Address (I2CMSA)

I2C 0 base: 0x4002.0000
 I2C 1 base: 0x4002.1000
 I2C 2 base: 0x4002.2000
 I2C 3 base: 0x4002.3000
 I2C 4 base: 0x400C.0000
 I2C 5 base: 0x400C.1000
 Offset 0x000
 Type R/W, reset 0x0000.0000

	31	30	29	28	27	26	25	24	23	22	21	20	19	18	17	16
	reserved															
Type	RO	RO	RO	RO	RO	RO	RO	RO	RO	RO	RO	RO	RO	RO	RO	RO
Reset	0	0	0	0	0	0	0	0	0	0	0	0	0	0	0	0
	15	14	13	12	11	10	9	8	7	6	5	4	3	2	1	0
	reserved								SA							R/S
Type	RO	RO	RO	RO	RO	RO	RO	RO	R/W	R/W	R/W	R/W	R/W	R/W	R/W	R/W
Reset	0	0	0	0	0	0	0	0	0	0	0	0	0	0	0	0

Bit/Field	Name	Type	Reset	Description
31:8	reserved	RO	0x0000.00	Software should not rely on the value of a reserved bit. To provide compatibility with future products, the value of a reserved bit should be preserved across a read-modify-write operation.
7:1	SA	R/W	0x00	I ² C Slave Address This field specifies bits A6 through A0 of the slave address.
0	R/S	R/W	0	Receive/Send The R/S bit specifies if the next operation is a Receive (High) or Transmit (Low).
				Value Description
				0 Transmit
				1 Receive

Register 2: I²C Master Control/Status (I2CMCS), offset 0x004

This register accesses status bits when read and control bits when written. When read, the status register indicates the state of the I²C bus controller. When written, the control register configures the I²C controller operation.

The **START** bit generates the **START** or **REPEATED START** condition. The **STOP** bit determines if the cycle stops at the end of the data cycle or continues on to a repeated **START** condition. To generate a single transmit cycle, the **I²C Master Slave Address (I2CMSA)** register is written with the desired address, the **R/S** bit is cleared, and this register is written with **ACK=X** (0 or 1), **STOP=1**, **START=1**, and **RUN=1** to perform the operation and stop. When the operation is completed (or aborted due an error), an interrupt becomes active and the data may be read from the **I2CMDR** register. When the I²C module operates in Master receiver mode, the **ACK** bit is normally set, causing the I²C bus controller to transmit an acknowledge automatically after each byte. This bit must be cleared when the I²C bus controller requires no further data to be transmitted from the slave transmitter.

Read-Only Status Register

I2C Master Control/Status (I2CMCS)

I2C 0 base: 0x4002.0000
 I2C 1 base: 0x4002.1000
 I2C 2 base: 0x4002.2000
 I2C 3 base: 0x4002.3000
 I2C 4 base: 0x400C.0000
 I2C 5 base: 0x400C.1000
 Offset 0x004
 Type RO, reset 0x0000.0020

	31	30	29	28	27	26	25	24	23	22	21	20	19	18	17	16
	reserved															
Type	RO	RO	RO	RO	RO	RO	RO	RO	RO	RO	RO	RO	RO	RO	RO	RO
Reset	0	0	0	0	0	0	0	0	0	0	0	0	0	0	0	0
	15	14	13	12	11	10	9	8	7	6	5	4	3	2	1	0
	reserved								CLKTO	BUSBSY	IDLE	ARBLST	DATAACK	ADRACK	ERROR	BUSY
Type	RO	RO	RO	RO	RO	RO	RO	RO	RO	RO	RO	RO	RO	RO	RO	RO
Reset	0	0	0	0	0	0	0	0	0	0	1	0	0	0	0	0

Bit/Field	Name	Type	Reset	Description
31:8	reserved	RO	0x0000.00	Software should not rely on the value of a reserved bit. To provide compatibility with future products, the value of a reserved bit should be preserved across a read-modify-write operation.
7	CLKTO	RO	0	Clock Timeout Error
				Value Description
			0	No clock timeout error.
			1	The clock timeout error has occurred.
				This bit is cleared when the master sends a STOP condition or if the I ² C master is reset.

Bit/Field	Name	Type	Reset	Description
6	BUSBSY	RO	0	<p>Bus Busy</p> <p>Value Description</p> <p>0 The I²C bus is idle.</p> <p>1 The I²C bus is busy.</p> <p>The bit changes based on the START and STOP conditions.</p>
5	IDLE	RO	1	<p>I²C Idle</p> <p>Value Description</p> <p>0 The I²C controller is not idle.</p> <p>1 The I²C controller is idle.</p>
4	ARBLST	RO	0	<p>Arbitration Lost</p> <p>Value Description</p> <p>0 The I²C controller won arbitration.</p> <p>1 The I²C controller lost arbitration.</p>
3	DATAACK	RO	0	<p>Acknowledge Data</p> <p>Value Description</p> <p>0 The transmitted data was acknowledged</p> <p>1 The transmitted data was not acknowledged.</p>
2	ADRACK	RO	0	<p>Acknowledge Address</p> <p>Value Description</p> <p>0 The transmitted address was acknowledged</p> <p>1 The transmitted address was not acknowledged.</p>
1	ERROR	RO	0	<p>Error</p> <p>Value Description</p> <p>0 No error was detected on the last operation.</p> <p>1 An error occurred on the last operation.</p> <p>The error can be from the slave address not being acknowledged or the transmit data not being acknowledged.</p>
0	BUSY	RO	0	<p>I²C Busy</p> <p>Value Description</p> <p>0 The controller is idle.</p> <p>1 The controller is busy.</p> <p>When the <code>BUSY</code> bit is set, the other status bits are not valid.</p>

Write-Only Control Register

I2C Master Control/Status (I2CMCS)

I2C 0 base: 0x4002.0000
 I2C 1 base: 0x4002.1000
 I2C 2 base: 0x4002.2000
 I2C 3 base: 0x4002.3000
 I2C 4 base: 0x400C.0000
 I2C 5 base: 0x400C.1000
 Offset 0x004
 Type WO, reset 0x0000.0020

	31	30	29	28	27	26	25	24	23	22	21	20	19	18	17	16	
	reserved																
Type	RO	RO	RO	RO	RO	RO	RO	RO	RO	RO	RO	RO	RO	RO	RO	RO	
Reset	0	0	0	0	0	0	0	0	0	0	0	0	0	0	0	0	
	15	14	13	12	11	10	9	8	7	6	5	4	3	2	1	0	
	reserved												HS	ACK	STOP	START	RUN
Type	RO	RO	RO	RO	RO	RO	RO	RO	RO	RO	RO	RO	WO	WO	WO	WO	WO
Reset	0	0	0	0	0	0	0	0	0	0	0	0	0	0	0	0	0

Bit/Field	Name	Type	Reset	Description
31:5	reserved	RO	0	Software should not rely on the value of a reserved bit. To provide compatibility with future products, the value of a reserved bit should be preserved across a read-modify-write operation.
4	HS	WO	0	High-Speed Enable Value Description 0 The master operates in Standard, Fast mode, or Fast mode plus as selected by using a value in the I2CMTPR register that results in an SCL frequency of 100 kbps for Standard mode, 400 kbps for Fast mode, or 1 Mbps for Fast mode plus. 1 The master operates in High-Speed mode with transmission speeds up to 3.33 Mbps.
3	ACK	WO	0	Data Acknowledge Enable Value Description 0 The received data byte is not acknowledged automatically by the master. 1 The received data byte is acknowledged automatically by the master. See field decoding in Table 15-5 on page 985.
2	STOP	WO	0	Generate STOP Value Description 0 The controller does not generate the STOP condition. 1 The controller generates the STOP condition. See field decoding in Table 15-5 on page 985.

Bit/Field	Name	Type	Reset	Description
1	START	WO	0	Generate START Value Description 0 The controller does not generate the START condition. 1 The controller generates the START or repeated START condition. See field decoding in Table 15-5 on page 985.
0	RUN	WO	0	I ² C Master Enable Value Description 0 The master is disabled. 1 The master is enabled to transmit or receive data. See field decoding in Table 15-5 on page 985.

Table 15-5. Write Field Decoding for I2CMCS[3:0] Field

Current State	I2CMSA[0]	I2CMCS[3:0]				Description
	R/S	ACK	STOP	START	RUN	
Idle	0	X ^a	0	1	1	START condition followed by TRANSMIT (master goes to the Master Transmit state).
	0	X	1	1	1	START condition followed by a TRANSMIT and STOP condition (master remains in Idle state).
	1	0	0	1	1	START condition followed by RECEIVE operation with negative ACK (master goes to the Master Receive state).
	1	0	1	1	1	START condition followed by RECEIVE and STOP condition (master remains in Idle state).
	1	1	0	1	1	START condition followed by RECEIVE (master goes to the Master Receive state).
	1	1	1	1	1	Illegal
	All other combinations not listed are non-operations.					
Master Transmit	X	X	0	0	1	TRANSMIT operation (master remains in Master Transmit state).
	X	X	1	0	0	STOP condition (master goes to Idle state).
	X	X	1	0	1	TRANSMIT followed by STOP condition (master goes to Idle state).
	0	X	0	1	1	Repeated START condition followed by a TRANSMIT (master remains in Master Transmit state).
	0	X	1	1	1	Repeated START condition followed by TRANSMIT and STOP condition (master goes to Idle state).
	1	0	0	1	1	Repeated START condition followed by a RECEIVE operation with a negative ACK (master goes to Master Receive state).
	1	0	1	1	1	Repeated START condition followed by a TRANSMIT and STOP condition (master goes to Idle state).
	1	1	0	1	1	Repeated START condition followed by RECEIVE (master goes to Master Receive state).
	1	1	1	1	1	Illegal.
	All other combinations not listed are non-operations.					

Table 15-5. Write Field Decoding for I2CMCS[3:0] Field (continued)

Current State	I2CMSA[0]	I2CMCS[3:0]				Description
	R/S	ACK	STOP	START	RUN	
Master Receive	X	0	0	0	1	RECEIVE operation with negative ACK (master remains in Master Receive state).
	X	X	1	0	0	STOP condition (master goes to Idle state). ^b
	X	0	1	0	1	RECEIVE followed by STOP condition (master goes to Idle state).
	X	1	0	0	1	RECEIVE operation (master remains in Master Receive state).
	X	1	1	0	1	Illegal.
	1	0	0	1	1	Repeated START condition followed by RECEIVE operation with a negative ACK (master remains in Master Receive state).
	1	0	1	1	1	Repeated START condition followed by RECEIVE and STOP condition (master goes to Idle state).
	1	1	0	1	1	Repeated START condition followed by RECEIVE (master remains in Master Receive state).
	0	X	0	1	1	Repeated START condition followed by TRANSMIT (master goes to Master Transmit state).
	0	X	1	1	1	Repeated START condition followed by TRANSMIT and STOP condition (master goes to Idle state).
	All other combinations not listed are non-operations.					

a. An X in a table cell indicates the bit can be 0 or 1.

b. In Master Receive mode, a STOP condition should be generated only after a Data Negative Acknowledge executed by the master or an Address Negative Acknowledge executed by the slave.

Register 3: I²C Master Data (I2CMDR), offset 0x008

Important: This register is read-sensitive. See the register description for details.

This register contains the data to be transmitted when in the Master Transmit state and the data received when in the Master Receive state.

I2C Master Data (I2CMDR)

I2C 0 base: 0x4002.0000
 I2C 1 base: 0x4002.1000
 I2C 2 base: 0x4002.2000
 I2C 3 base: 0x4002.3000
 I2C 4 base: 0x400C.0000
 I2C 5 base: 0x400C.1000
 Offset 0x008
 Type R/W, reset 0x0000.0000

	31	30	29	28	27	26	25	24	23	22	21	20	19	18	17	16
	reserved															
Type	RO	RO	RO	RO	RO	RO	RO	RO	RO	RO	RO	RO	RO	RO	RO	RO
Reset	0	0	0	0	0	0	0	0	0	0	0	0	0	0	0	0
	15	14	13	12	11	10	9	8	7	6	5	4	3	2	1	0
	reserved								DATA							
Type	RO	RO	RO	RO	RO	RO	RO	RO	R/W	R/W	R/W	R/W	R/W	R/W	R/W	R/W
Reset	0	0	0	0	0	0	0	0	0	0	0	0	0	0	0	0

Bit/Field	Name	Type	Reset	Description
31:8	reserved	RO	0x0000.00	Software should not rely on the value of a reserved bit. To provide compatibility with future products, the value of a reserved bit should be preserved across a read-modify-write operation.
7:0	DATA	R/W	0x00	Data Transferred Data transferred during transaction.

Register 4: I²C Master Timer Period (I2CMTPR), offset 0x00C

This register is programmed to set the timer period for the SCL clock and assign the SCL clock to either standard or high-speed mode.

I2C Master Timer Period (I2CMTPR)

I2C 0 base: 0x4002.0000
 I2C 1 base: 0x4002.1000
 I2C 2 base: 0x4002.2000
 I2C 3 base: 0x4002.3000
 I2C 4 base: 0x400C.0000
 I2C 5 base: 0x400C.1000
 Offset 0x00C
 Type R/W, reset 0x0000.0001

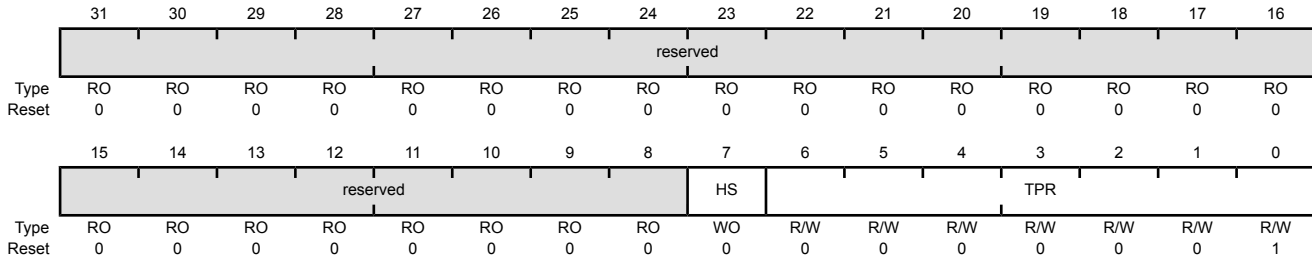

Bit/Field	Name	Type	Reset	Description
31:8	reserved	RO	0x0000.00	Software should not rely on the value of a reserved bit. To provide compatibility with future products, the value of a reserved bit should be preserved across a read-modify-write operation.
7	HS	WO	0x0	High-Speed Enable Value Description 1 The SCL Clock Period set by TPR applies to High-speed mode (3.33 Mbps). 0 The SCL Clock Period set by TPR applies to Standard mode (100 Kbps), Fast-mode (400 Kbps), or Fast-mode plus (1 Mbps).
6:0	TPR	R/W	0x1	SCL Clock Period This field specifies the period of the SCL clock. $SCL_PRD = 2 \times (1 + TPR) \times (SCL_LP + SCL_HP) \times CLK_PRD$ where: SCL_PRD is the SCL line period (I ² C clock). TPR is the Timer Period register value (range of 1 to 127). SCL_LP is the SCL Low period (fixed at 6). SCL_HP is the SCL High period (fixed at 4). CLK_PRD is the system clock period in ns.

Register 5: I²C Master Interrupt Mask (I2CMIMR), offset 0x010

This register controls whether a raw interrupt is promoted to a controller interrupt.

I2C Master Interrupt Mask (I2CMIMR)

I2C 0 base: 0x4002.0000
 I2C 1 base: 0x4002.1000
 I2C 2 base: 0x4002.2000
 I2C 3 base: 0x4002.3000
 I2C 4 base: 0x400C.0000
 I2C 5 base: 0x400C.1000
 Offset 0x010
 Type R/W, reset 0x0000.0000

	31	30	29	28	27	26	25	24	23	22	21	20	19	18	17	16
	reserved															
Type	RO	RO	RO	RO	RO	RO	RO	RO	RO	RO	RO	RO	RO	RO	RO	RO
Reset	0	0	0	0	0	0	0	0	0	0	0	0	0	0	0	0
	15	14	13	12	11	10	9	8	7	6	5	4	3	2	1	0
	reserved														CLKIM	IM
Type	RO	RO	RO	RO	RO	RO	RO	RO	RO	RO	RO	RO	RO	RO	R/W	R/W
Reset	0	0	0	0	0	0	0	0	0	0	0	0	0	0	0	0

Bit/Field	Name	Type	Reset	Description
31:2	reserved	RO	0	Software should not rely on the value of a reserved bit. To provide compatibility with future products, the value of a reserved bit should be preserved across a read-modify-write operation.
1	CLKIM	R/W	0	Clock Timeout Interrupt Mask
				Value Description
				1 The clock timeout interrupt is sent to the interrupt controller when the CLKRIS bit in the I2CMRIS register is set.
				0 The CLKRIS interrupt is suppressed and not sent to the interrupt controller.
0	IM	R/W	0	Master Interrupt Mask
				Value Description
				1 The master interrupt is sent to the interrupt controller when the RIS bit in the I2CMRIS register is set.
				0 The RIS interrupt is suppressed and not sent to the interrupt controller.

Register 6: I²C Master Raw Interrupt Status (I2CMRIS), offset 0x014

This register specifies whether an interrupt is pending.

I2C Master Raw Interrupt Status (I2CMRIS)

I2C 0 base: 0x4002.0000
 I2C 1 base: 0x4002.1000
 I2C 2 base: 0x4002.2000
 I2C 3 base: 0x4002.3000
 I2C 4 base: 0x400C.0000
 I2C 5 base: 0x400C.1000
 Offset 0x014
 Type RO, reset 0x0000.0000

	31	30	29	28	27	26	25	24	23	22	21	20	19	18	17	16	
	reserved																
Type	RO	RO	RO	RO	RO	RO	RO	RO	RO	RO	RO	RO	RO	RO	RO	RO	
Reset	0	0	0	0	0	0	0	0	0	0	0	0	0	0	0	0	
	15	14	13	12	11	10	9	8	7	6	5	4	3	2	1	0	
	reserved															CLKRIS	RIS
Type	RO	RO	RO	RO	RO	RO	RO	RO	RO	RO	RO	RO	RO	RO	RO	RO	RO
Reset	0	0	0	0	0	0	0	0	0	0	0	0	0	0	0	0	0

Bit/Field	Name	Type	Reset	Description
31:2	reserved	RO	0	Software should not rely on the value of a reserved bit. To provide compatibility with future products, the value of a reserved bit should be preserved across a read-modify-write operation.
1	CLKRIS	RO	0	Clock Timeout Raw Interrupt Status Value Description 1 The clock timeout interrupt is pending. 0 No interrupt. This bit is cleared by writing a 1 to the CLKIC bit in the I2CMICR register.
0	RIS	RO	0	Master Raw Interrupt Status Value Description 1 A master interrupt is pending. 0 No interrupt. This bit is cleared by writing a 1 to the IC bit in the I2CMICR register.

Register 7: I²C Master Masked Interrupt Status (I2CMMIS), offset 0x018

This register specifies whether an interrupt was signaled.

I2C Master Masked Interrupt Status (I2CMMIS)

I2C 0 base: 0x4002.0000
 I2C 1 base: 0x4002.1000
 I2C 2 base: 0x4002.2000
 I2C 3 base: 0x4002.3000
 I2C 4 base: 0x400C.0000
 I2C 5 base: 0x400C.1000
 Offset 0x018
 Type RO, reset 0x0000.0000

	31	30	29	28	27	26	25	24	23	22	21	20	19	18	17	16	
	reserved																
Type	RO	RO	RO	RO	RO	RO	RO	RO	RO	RO	RO	RO	RO	RO	RO	RO	
Reset	0	0	0	0	0	0	0	0	0	0	0	0	0	0	0	0	
	15	14	13	12	11	10	9	8	7	6	5	4	3	2	1	0	
	reserved															CLKMIS	MIS
Type	RO	RO	RO	RO	RO	RO	RO	RO	RO	RO	RO	RO	RO	RO	RO	RO	RO
Reset	0	0	0	0	0	0	0	0	0	0	0	0	0	0	0	0	0

Bit/Field	Name	Type	Reset	Description
31:2	reserved	RO	0	Software should not rely on the value of a reserved bit. To provide compatibility with future products, the value of a reserved bit should be preserved across a read-modify-write operation.
1	CLKMIS	RO	0	Clock Timeout Masked Interrupt Status Value Description 1 An unmasked clock timeout interrupt was signaled and is pending. 0 No interrupt. This bit is cleared by writing a 1 to the <code>CLKIC</code> bit in the I2CMICR register.
0	MIS	RO	0	Masked Interrupt Status Value Description 1 An unmasked master interrupt was signaled and is pending. 0 An interrupt has not occurred or is masked. This bit is cleared by writing a 1 to the <code>IC</code> bit in the I2CMICR register.

Register 8: I²C Master Interrupt Clear (I2CMICR), offset 0x01C

This register clears the raw and masked interrupts.

I2C Master Interrupt Clear (I2CMICR)

I2C 0 base: 0x4002.0000
 I2C 1 base: 0x4002.1000
 I2C 2 base: 0x4002.2000
 I2C 3 base: 0x4002.3000
 I2C 4 base: 0x400C.0000
 I2C 5 base: 0x400C.1000
 Offset 0x01C
 Type WO, reset 0x0000.0000

	31	30	29	28	27	26	25	24	23	22	21	20	19	18	17	16	
	reserved																
Type	RO	RO	RO	RO	RO	RO	RO	RO	RO	RO	RO	RO	RO	RO	RO	RO	
Reset	0	0	0	0	0	0	0	0	0	0	0	0	0	0	0	0	
	15	14	13	12	11	10	9	8	7	6	5	4	3	2	1	0	
	reserved															CLKIC	IC
Type	RO	RO	RO	RO	RO	RO	RO	RO	RO	RO	RO	RO	RO	RO	RO	WO	WO
Reset	0	0	0	0	0	0	0	0	0	0	0	0	0	0	0	0	0

Bit/Field	Name	Type	Reset	Description
31:2	reserved	RO	0	Software should not rely on the value of a reserved bit. To provide compatibility with future products, the value of a reserved bit should be preserved across a read-modify-write operation.
1	CLKIC	WO	0	Clock Timeout Interrupt Clear Writing a 1 to this bit clears the CLKRIS bit in the I2CMRIS register and the CLKMIS bit in the I2CMMIS register. A read of this register returns no meaningful data.
0	IC	WO	0	Master Interrupt Clear Writing a 1 to this bit clears the RIS bit in the I2CMRIS register and the MIS bit in the I2CMMIS register. A read of this register returns no meaningful data.

Register 9: I²C Master Configuration (I2CMCR), offset 0x020

This register configures the mode (Master or Slave) and sets the interface for test mode loopback.

I2C Master Configuration (I2CMCR)

I2C 0 base: 0x4002.0000
 I2C 1 base: 0x4002.1000
 I2C 2 base: 0x4002.2000
 I2C 3 base: 0x4002.3000
 I2C 4 base: 0x400C.0000
 I2C 5 base: 0x400C.1000
 Offset 0x020
 Type R/W, reset 0x0000.0000

	31	30	29	28	27	26	25	24	23	22	21	20	19	18	17	16	
	reserved																
Type	RO	RO	RO	RO	RO	RO	RO	RO	RO	RO	RO	RO	RO	RO	RO	RO	
Reset	0	0	0	0	0	0	0	0	0	0	0	0	0	0	0	0	
	15	14	13	12	11	10	9	8	7	6	5	4	3	2	1	0	
	reserved											SFE	MFE	reserved		LPBK	
Type	RO	RO	RO	RO	RO	RO	RO	RO	RO	RO	RO	R/W	R/W	RO	RO	RO	R/W
Reset	0	0	0	0	0	0	0	0	0	0	0	0	0	0	0	0	0

Bit/Field	Name	Type	Reset	Description
31:6	reserved	RO	0x0000.00	Software should not rely on the value of a reserved bit. To provide compatibility with future products, the value of a reserved bit should be preserved across a read-modify-write operation.
5	SFE	R/W	0	I ² C Slave Function Enable Value Description 1 Slave mode is enabled. 0 Slave mode is disabled.
4	MFE	R/W	0	I ² C Master Function Enable Value Description 1 Master mode is enabled. 0 Master mode is disabled.
3:1	reserved	RO	0x0	Software should not rely on the value of a reserved bit. To provide compatibility with future products, the value of a reserved bit should be preserved across a read-modify-write operation.
0	LPBK	R/W	0	I ² C Loopback Value Description 1 The controller in a test mode loopback configuration. 0 Normal operation.

Register 10: I²C Master Clock Low Timeout Count (I2CMCLKOCNT), offset 0x024

This register contains the upper 8 bits of a 12-bit counter that can be used to keep the timeout limit for clock stretching by a remote slave. The lower four bits of the counter are not user visible.

I2C Master Clock Low Timeout Count (I2CMCLKOCNT)

I2C 0 base: 0x4002.0000
 I2C 1 base: 0x4002.1000
 I2C 2 base: 0x4002.2000
 I2C 3 base: 0x4002.3000
 I2C 4 base: 0x400C.0000
 I2C 5 base: 0x400C.1000
 Offset 0x024
 Type R/W, reset 0x0000.0000

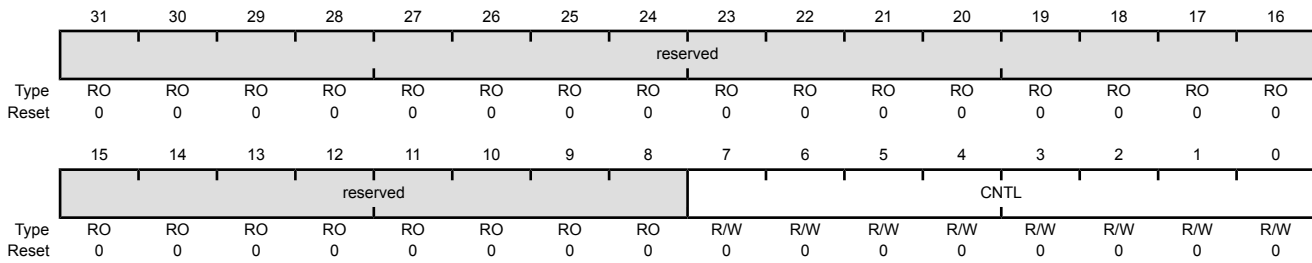

Bit/Field	Name	Type	Reset	Description
31:8	reserved	RO	0x0000.00	Software should not rely on the value of a reserved bit. To provide compatibility with future products, the value of a reserved bit should be preserved across a read-modify-write operation.
7:0	CNTL	R/W	0	I ² C Master Count This field contains the upper 8 bits of a 12-bit counter for the clock low timeout count.

Register 11: I²C Master Bus Monitor (I2CMBMON), offset 0x02C

This register is used to determine the SCL and SDA signal status.

I2C Master Bus Monitor (I2CMBMON)

I2C 0 base: 0x4002.0000
 I2C 1 base: 0x4002.1000
 I2C 2 base: 0x4002.2000
 I2C 3 base: 0x4002.3000
 I2C 4 base: 0x400C.0000
 I2C 5 base: 0x400C.1000
 Offset 0x02C
 Type RO, reset 0x0000.0003

	31	30	29	28	27	26	25	24	23	22	21	20	19	18	17	16	
	reserved																
Type	RO	RO	RO	RO	RO	RO	RO	RO	RO	RO	RO	RO	RO	RO	RO	RO	
Reset	0	0	0	0	0	0	0	0	0	0	0	0	0	0	0	0	
	15	14	13	12	11	10	9	8	7	6	5	4	3	2	1	0	
	reserved															SDA	SCL
Type	RO	RO	RO	RO	RO	RO	RO	RO	RO	RO	RO	RO	RO	RO	RO	RO	RO
Reset	0	0	0	0	0	0	0	0	0	0	0	0	0	0	1	1	

Bit/Field	Name	Type	Reset	Description
31:2	reserved	RO	0x0000.000	Software should not rely on the value of a reserved bit. To provide compatibility with future products, the value of a reserved bit should be preserved across a read-modify-write operation.
1	SDA	RO	1	I ² C SDA Status Value Description 1 The I2CSDA signal is high. 0 The I2CSDA signal is low.
0	SCL	RO	1	I ² C SCL Status Value Description 1 The I2CSCL signal is high. 0 The I2CSCL signal is low.

15.7 Register Descriptions (I²C Slave)

The remainder of this section lists and describes the I²C slave registers, in numerical order by address offset.

Register 12: I²C Slave Own Address (I2CSOAR), offset 0x800

This register consists of seven address bits that identify the Stellaris I²C device on the I²C bus.

I2C Slave Own Address (I2CSOAR)

I2C 0 base: 0x4002.0000
 I2C 1 base: 0x4002.1000
 I2C 2 base: 0x4002.2000
 I2C 3 base: 0x4002.3000
 I2C 4 base: 0x400C.0000
 I2C 5 base: 0x400C.1000
 Offset 0x800
 Type R/W, reset 0x0000.0000

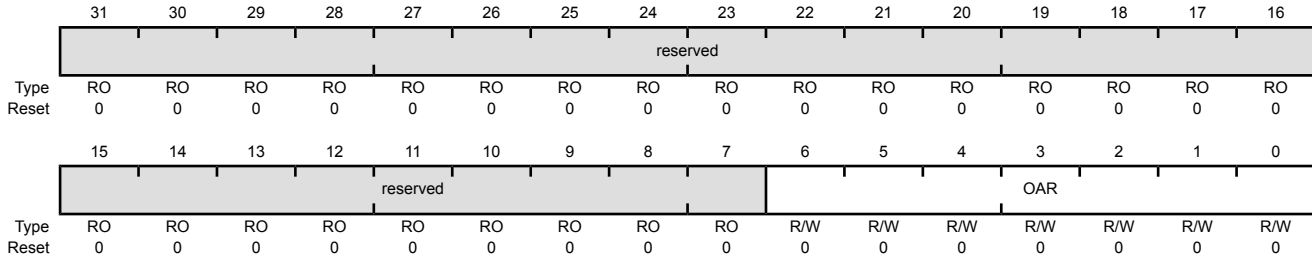

Bit/Field	Name	Type	Reset	Description
31:7	reserved	RO	0x0000.00	Software should not rely on the value of a reserved bit. To provide compatibility with future products, the value of a reserved bit should be preserved across a read-modify-write operation.
6:0	OAR	R/W	0x00	I ² C Slave Own Address This field specifies bits A6 through A0 of the slave address.

Register 13: I²C Slave Control/Status (I2CCSR), offset 0x804

This register functions as a control register when written, and a status register when read.

Read-Only Status Register

I2C Slave Control/Status (I2CCSR)

I2C 0 base: 0x4002.0000
 I2C 1 base: 0x4002.1000
 I2C 2 base: 0x4002.2000
 I2C 3 base: 0x4002.3000
 I2C 4 base: 0x400C.0000
 I2C 5 base: 0x400C.1000
 Offset 0x804
 Type RO, reset 0x0000.0000

	31	30	29	28	27	26	25	24	23	22	21	20	19	18	17	16
	reserved															
Type	RO	RO	RO	RO	RO	RO	RO	RO	RO	RO	RO	RO	RO	RO	RO	RO
Reset	0	0	0	0	0	0	0	0	0	0	0	0	0	0	0	0
	15	14	13	12	11	10	9	8	7	6	5	4	3	2	1	0
	reserved												OAR2SEL	FBR	TREQ	RREQ
Type	RO	RO	RO	RO	RO	RO	RO	RO	RO	RO	RO	RO	RO	RO	RO	RO
Reset	0	0	0	0	0	0	0	0	0	0	0	0	0	0	0	0

Bit/Field	Name	Type	Reset	Description
31:4	reserved	RO	0x0000.000	Software should not rely on the value of a reserved bit. To provide compatibility with future products, the value of a reserved bit should be preserved across a read-modify-write operation.
3	OAR2SEL	RO	0	OAR2 Address Matched Value Description 1 OAR2 address matched and ACKed by the slave. 0 Either the address is not matched or the match is in legacy mode. This bit gets reevaluated after every address comparison.
2	FBR	RO	0	First Byte Received Value Description 1 The first byte following the slave's own address has been received. 0 The first byte has not been received. This bit is only valid when the RREQ bit is set and is automatically cleared when data has been read from the I2CSDR register. Note: This bit is not used for slave transmit operations.

Bit/Field	Name	Type	Reset	Description
1	TREQ	RO	0	Transmit Request Value Description 1 The I ² C controller has been addressed as a slave transmitter and is using clock stretching to delay the master until data has been written to the I2CSDR register. 0 No outstanding transmit request.
0	RREQ	RO	0	Receive Request Value Description 1 The I ² C controller has outstanding receive data from the I ² C master and is using clock stretching to delay the master until the data has been read from the I2CSDR register. 0 No outstanding receive data.

Write-Only Control Register

I2C Slave Control/Status (I2CSCSR)

I2C 0 base: 0x4002.0000
 I2C 1 base: 0x4002.1000
 I2C 2 base: 0x4002.2000
 I2C 3 base: 0x4002.3000
 I2C 4 base: 0x400C.0000
 I2C 5 base: 0x400C.1000
 Offset 0x804
 Type WO, reset 0x0000.0000

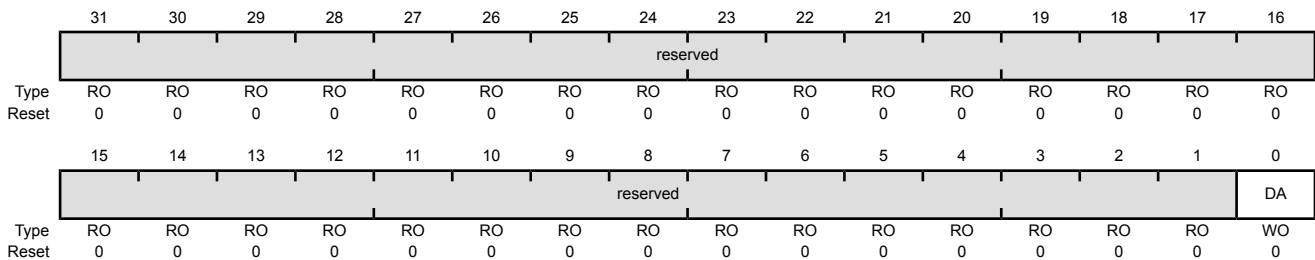

Bit/Field	Name	Type	Reset	Description
31:1	reserved	RO	0x0000.000	Software should not rely on the value of a reserved bit. To provide compatibility with future products, the value of a reserved bit should be preserved across a read-modify-write operation.
0	DA	WO	0	Device Active Value Description 0 Disables the I ² C slave operation. 1 Enables the I ² C slave operation. Once this bit has been set, it should not be set again unless it has been cleared by writing a 0 or by a reset, otherwise transfer failures may occur.

Register 14: I²C Slave Data (I2CSDR), offset 0x808

Important: This register is read-sensitive. See the register description for details.

This register contains the data to be transmitted when in the Slave Transmit state, and the data received when in the Slave Receive state.

I2C Slave Data (I2CSDR)

I2C 0 base: 0x4002.0000
 I2C 1 base: 0x4002.1000
 I2C 2 base: 0x4002.2000
 I2C 3 base: 0x4002.3000
 I2C 4 base: 0x400C.0000
 I2C 5 base: 0x400C.1000
 Offset 0x808
 Type R/W, reset 0x0000.0000

	31	30	29	28	27	26	25	24	23	22	21	20	19	18	17	16
	reserved															
Type	RO	RO	RO	RO	RO	RO	RO	RO	RO	RO	RO	RO	RO	RO	RO	RO
Reset	0	0	0	0	0	0	0	0	0	0	0	0	0	0	0	0
	15	14	13	12	11	10	9	8	7	6	5	4	3	2	1	0
	reserved								DATA							
Type	RO	RO	RO	RO	RO	RO	RO	RO	R/W	R/W	R/W	R/W	R/W	R/W	R/W	R/W
Reset	0	0	0	0	0	0	0	0	0	0	0	0	0	0	0	0

Bit/Field	Name	Type	Reset	Description
31:8	reserved	RO	0x0000.00	Software should not rely on the value of a reserved bit. To provide compatibility with future products, the value of a reserved bit should be preserved across a read-modify-write operation.
7:0	DATA	R/W	0x00	Data for Transfer This field contains the data for transfer during a slave receive or transmit operation.

Register 15: I²C Slave Interrupt Mask (I2CSIMR), offset 0x80C

This register controls whether a raw interrupt is promoted to a controller interrupt.

I2C Slave Interrupt Mask (I2CSIMR)

I2C 0 base: 0x4002.0000
 I2C 1 base: 0x4002.1000
 I2C 2 base: 0x4002.2000
 I2C 3 base: 0x4002.3000
 I2C 4 base: 0x400C.0000
 I2C 5 base: 0x400C.1000
 Offset 0x80C
 Type R/W, reset 0x0000.0000

	31	30	29	28	27	26	25	24	23	22	21	20	19	18	17	16
	reserved															
Type	RO	RO	RO	RO	RO	RO	RO	RO	RO	RO	RO	RO	RO	RO	RO	RO
Reset	0	0	0	0	0	0	0	0	0	0	0	0	0	0	0	0
	15	14	13	12	11	10	9	8	7	6	5	4	3	2	1	0
	reserved													STOPI	START	DATA
Type	RO	RO	RO	RO	RO	RO	RO	RO	RO	RO	RO	RO	RO	R/W	R/W	R/W
Reset	0	0	0	0	0	0	0	0	0	0	0	0	0	0	0	0

Bit/Field	Name	Type	Reset	Description
31:3	reserved	RO	0	Software should not rely on the value of a reserved bit. To provide compatibility with future products, the value of a reserved bit should be preserved across a read-modify-write operation.
2	STOPI	R/W	0	Stop Condition Interrupt Mask Value Description 1 The STOP condition interrupt is sent to the interrupt controller when the STOPRIS bit in the I2CSRIS register is set. 0 The STOPRIS interrupt is suppressed and not sent to the interrupt controller.
1	START	R/W	0	Start Condition Interrupt Mask Value Description 1 The START condition interrupt is sent to the interrupt controller when the STARTRIS bit in the I2CSRIS register is set. 0 The STARTRIS interrupt is suppressed and not sent to the interrupt controller.
0	DATA	R/W	0	Data Interrupt Mask Value Description 1 The data received or data requested interrupt is sent to the interrupt controller when the DATARIS bit in the I2CSRIS register is set. 0 The DATARIS interrupt is suppressed and not sent to the interrupt controller.

Register 16: I²C Slave Raw Interrupt Status (I2CSRIS), offset 0x810

This register specifies whether an interrupt is pending.

I2C Slave Raw Interrupt Status (I2CSRIS)

I2C 0 base: 0x4002.0000
 I2C 1 base: 0x4002.1000
 I2C 2 base: 0x4002.2000
 I2C 3 base: 0x4002.3000
 I2C 4 base: 0x400C.0000
 I2C 5 base: 0x400C.1000
 Offset 0x810
 Type RO, reset 0x0000.0000

	31	30	29	28	27	26	25	24	23	22	21	20	19	18	17	16
	reserved															
Type	RO	RO	RO	RO	RO	RO	RO	RO	RO	RO	RO	RO	RO	RO	RO	RO
Reset	0	0	0	0	0	0	0	0	0	0	0	0	0	0	0	0
	15	14	13	12	11	10	9	8	7	6	5	4	3	2	1	0
	reserved													STOPRIS	STARTRIS	DATARIS
Type	RO	RO	RO	RO	RO	RO	RO	RO	RO	RO	RO	RO	RO	RO	RO	RO
Reset	0	0	0	0	0	0	0	0	0	0	0	0	0	0	0	0

Bit/Field	Name	Type	Reset	Description
31:3	reserved	RO	0	Software should not rely on the value of a reserved bit. To provide compatibility with future products, the value of a reserved bit should be preserved across a read-modify-write operation.
2	STOPRIS	RO	0	Stop Condition Raw Interrupt Status Value Description 1 A STOP condition interrupt is pending. 0 No interrupt. This bit is cleared by writing a 1 to the STOPIC bit in the I2CSICR register.
1	STARTRIS	RO	0	Start Condition Raw Interrupt Status Value Description 1 A START condition interrupt is pending. 0 No interrupt. This bit is cleared by writing a 1 to the STARTIC bit in the I2CSICR register.
0	DATARIS	RO	0	Data Raw Interrupt Status Value Description 1 A data received or data requested interrupt is pending. 0 No interrupt. This bit is cleared by writing a 1 to the DATAIC bit in the I2CSICR register.

Register 17: I²C Slave Masked Interrupt Status (I2CSMIS), offset 0x814

This register specifies whether an interrupt was signaled.

I2C Slave Masked Interrupt Status (I2CSMIS)

I2C 0 base: 0x4002.0000
 I2C 1 base: 0x4002.1000
 I2C 2 base: 0x4002.2000
 I2C 3 base: 0x4002.3000
 I2C 4 base: 0x400C.0000
 I2C 5 base: 0x400C.1000
 Offset 0x814
 Type RO, reset 0x0000.0000

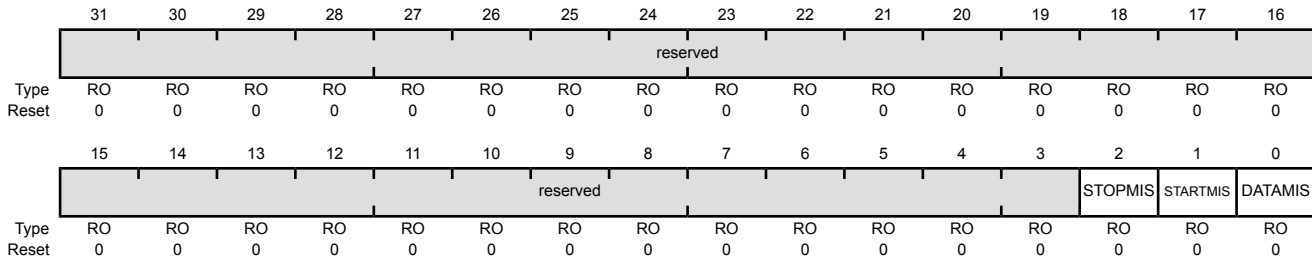

Bit/Field	Name	Type	Reset	Description
31:3	reserved	RO	0	Software should not rely on the value of a reserved bit. To provide compatibility with future products, the value of a reserved bit should be preserved across a read-modify-write operation.
2	STOPMIS	RO	0	Stop Condition Masked Interrupt Status Value Description 1 An unmasked STOP condition interrupt was signaled is pending. 0 An interrupt has not occurred or is masked. This bit is cleared by writing a 1 to the STOPIC bit in the I2CSICR register.
1	STARTMIS	RO	0	Start Condition Masked Interrupt Status Value Description 1 An unmasked START condition interrupt was signaled is pending. 0 An interrupt has not occurred or is masked. This bit is cleared by writing a 1 to the STARTIC bit in the I2CSICR register.
0	DATAMIS	RO	0	Data Masked Interrupt Status Value Description 1 An unmasked data received or data requested interrupt was signaled is pending. 0 An interrupt has not occurred or is masked. This bit is cleared by writing a 1 to the DATAIC bit in the I2CSICR register.

Register 18: I²C Slave Interrupt Clear (I2CSICR), offset 0x818

This register clears the raw interrupt. A read of this register returns no meaningful data.

I2C Slave Interrupt Clear (I2CSICR)

I2C 0 base: 0x4002.0000
 I2C 1 base: 0x4002.1000
 I2C 2 base: 0x4002.2000
 I2C 3 base: 0x4002.3000
 I2C 4 base: 0x400C.0000
 I2C 5 base: 0x400C.1000
 Offset 0x818
 Type WO, reset 0x0000.0000

	31	30	29	28	27	26	25	24	23	22	21	20	19	18	17	16	
	reserved																
Type	RO	RO	RO	RO	RO	RO	RO	RO	RO	RO	RO	RO	RO	RO	RO	RO	
Reset	0	0	0	0	0	0	0	0	0	0	0	0	0	0	0	0	
	15	14	13	12	11	10	9	8	7	6	5	4	3	2	1	0	
	reserved													STOPIC	STARTIC	DATAIC	
Type	RO	RO	RO	RO	RO	RO	RO	RO	RO	RO	RO	RO	RO	RO	WO	WO	WO
Reset	0	0	0	0	0	0	0	0	0	0	0	0	0	0	0	0	0

Bit/Field	Name	Type	Reset	Description
31:3	reserved	RO	0	Software should not rely on the value of a reserved bit. To provide compatibility with future products, the value of a reserved bit should be preserved across a read-modify-write operation.
2	STOPIC	WO	0	Stop Condition Interrupt Clear Writing a 1 to this bit clears the <i>STOPRIS</i> bit in the I2CSRIS register and the <i>STOPMIS</i> bit in the I2CSMIS register. A read of this register returns no meaningful data.
1	STARTIC	WO	0	Start Condition Interrupt Clear Writing a 1 to this bit clears the <i>STARTRIS</i> bit in the I2CSRIS register and the <i>STARTMIS</i> bit in the I2CSMIS register. A read of this register returns no meaningful data.
0	DATAIC	WO	0	Data Interrupt Clear Writing a 1 to this bit clears the <i>STOPRIS</i> bit in the I2CSRIS register and the <i>STOPMIS</i> bit in the I2CSMIS register. A read of this register returns no meaningful data.

Register 19: I²C Slave Own Address 2 (I2CSOAR2), offset 0x81C

This register consists of seven address bits that identify the alternate address for the I²C device on the I²C bus.

I2C Slave Own Address 2 (I2CSOAR2)

I2C 0 base: 0x4002.0000
 I2C 1 base: 0x4002.1000
 I2C 2 base: 0x4002.2000
 I2C 3 base: 0x4002.3000
 I2C 4 base: 0x400C.0000
 I2C 5 base: 0x400C.1000
 Offset 0x81C
 Type R/W, reset 0x0000.0000

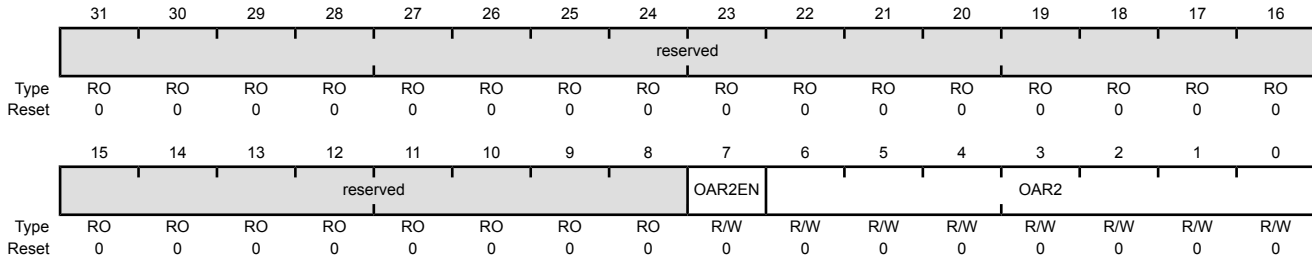

Bit/Field	Name	Type	Reset	Description
31:8	reserved	RO	0x0000.00	Software should not rely on the value of a reserved bit. To provide compatibility with future products, the value of a reserved bit should be preserved across a read-modify-write operation.
7	OAR2EN	R/W	0	I ² C Slave Own Address 2 Enable
				Value Description
				1 Enables the use of the alternate address in the OAR2 field.
				0 The alternate address is disabled.
6:0	OAR2	R/W	0x00	I ² C Slave Own Address 2 This field specifies the alternate OAR2 address.

Register 20: I²C Slave ACK Control (I2CSACKCTL), offset 0x820

This register enables the I²C slave to NACK for invalid data or command or ACK for valid data or command. The I²C clock is pulled low after the last data bit until this register is written.

I2C Slave ACK Control (I2CSACKCTL)

I2C 0 base: 0x4002.0000
 I2C 1 base: 0x4002.1000
 I2C 2 base: 0x4002.2000
 I2C 3 base: 0x4002.3000
 I2C 4 base: 0x400C.0000
 I2C 5 base: 0x400C.1000
 Offset 0x820
 Type R/W, reset 0x0000.0000

	31	30	29	28	27	26	25	24	23	22	21	20	19	18	17	16
	reserved															
Type	RO	RO	RO	RO	RO	RO	RO	RO	RO	RO	RO	RO	RO	RO	RO	RO
Reset	0	0	0	0	0	0	0	0	0	0	0	0	0	0	0	0
	15	14	13	12	11	10	9	8	7	6	5	4	3	2	1	0
	reserved														ACKOVAL	ACKOEN
Type	RO	RO	RO	RO	RO	RO	RO	RO	RO	RO	RO	RO	RO	RO	R/W	R/W
Reset	0	0	0	0	0	0	0	0	0	0	0	0	0	0	0	0

Bit/Field	Name	Type	Reset	Description
31:2	reserved	RO	0x0000.000	Software should not rely on the value of a reserved bit. To provide compatibility with future products, the value of a reserved bit should be preserved across a read-modify-write operation.
1	ACKOVAL	R/W	0	I ² C Slave ACK Override Value Value Description 1 A NACK is sent indicating invalid data or command. 0 An ACK is sent indicating valid data or command.
0	ACKOEN	R/W	0	I ² C Slave ACK Override Enable Value Description 1 An ACK or NACK is sent according to the value written to the ACKOVAL bit. 0 A response is not provided.

15.8 Register Descriptions (I²C Status and Control)

The remainder of this section lists and describes the I²C status and control registers, in numerical order by address offset.

Register 21: I²C Peripheral Properties (I2CPP), offset 0xFC0

The I2CPP register provides information regarding the properties of the I²C module.

I2C Peripheral Properties (I2CPP)

I2C 0 base: 0x4002.0000
 I2C 1 base: 0x4002.1000
 I2C 2 base: 0x4002.2000
 I2C 3 base: 0x4002.3000
 I2C 4 base: 0x400C.0000
 I2C 5 base: 0x400C.1000
 Offset 0xFC0
 Type RO, reset 0x0000.0001

	31	30	29	28	27	26	25	24	23	22	21	20	19	18	17	16
	reserved															
Type	RO	RO	RO	RO	RO	RO	RO	RO	RO	RO	RO	RO	RO	RO	RO	RO
Reset	0	0	0	0	0	0	0	0	0	0	0	0	0	0	0	0
	15	14	13	12	11	10	9	8	7	6	5	4	3	2	1	0
	reserved															HS
Type	RO	RO	RO	RO	RO	RO	RO	RO	RO	RO	RO	RO	RO	RO	RO	RO
Reset	0	0	0	0	0	0	0	0	0	0	0	0	0	0	0	1

Bit/Field	Name	Type	Reset	Description
31:1	reserved	RO	0x0	Software should not rely on the value of a reserved bit. To provide compatibility with future products, the value of a reserved bit should be preserved across a read-modify-write operation.
0	HS	RO	0x1	High-Speed Capable

Value	Description
1	The interface is capable of High-Speed operation.
0	The interface is capable of Standard, Fast, or Fast mode plus operation.

Register 22: I²C Peripheral Configuration (I2CPC), offset 0xFC4

The I2CPC register provides information regarding the configuration of the I²C module.

I2C Peripheral Configuration (I2CPC)

I2C 0 base: 0x4002.0000
 I2C 1 base: 0x4002.1000
 I2C 2 base: 0x4002.2000
 I2C 3 base: 0x4002.3000
 I2C 4 base: 0x400C.0000
 I2C 5 base: 0x400C.1000
 Offset 0xFC4
 Type RO, reset 0x0000.0001

	31	30	29	28	27	26	25	24	23	22	21	20	19	18	17	16
	reserved															
Type	RO	RO	RO	RO	RO	RO	RO	RO	RO	RO	RO	RO	RO	RO	RO	RO
Reset	0	0	0	0	0	0	0	0	0	0	0	0	0	0	0	0
	15	14	13	12	11	10	9	8	7	6	5	4	3	2	1	0
	reserved															HS
Type	RO	RO	RO	RO	RO	RO	RO	RO	RO	RO	RO	RO	RO	RO	RO	RO
Reset	0	0	0	0	0	0	0	0	0	0	0	0	0	0	0	1

Bit/Field	Name	Type	Reset	Description
31:1	reserved	RO	0	Software should not rely on the value of a reserved bit. To provide compatibility with future products, the value of a reserved bit should be preserved across a read-modify-write operation.

0	HS	RO	1	High-Speed Capable
---	----	----	---	--------------------

Value Description

- | | |
|---|---|
| 1 | The interface is set to High-Speed operation. Note that this encoding may only be used if the I2CPP HS bit is set. Otherwise, this encoding is not available. |
| 0 | The interface is set to Standard, Fast or Fast mode plus operation. |

16 Controller Area Network (CAN) Module

Controller Area Network (CAN) is a multicast, shared serial bus standard for connecting electronic control units (ECUs). CAN was specifically designed to be robust in electromagnetically-noisy environments and can utilize a differential balanced line like RS-485 or a more robust twisted-pair wire. Originally created for automotive purposes, it is also used in many embedded control applications (such as industrial and medical). Bit rates up to 1 Mbps are possible at network lengths less than 40 meters. Decreased bit rates allow longer network distances (for example, 125 Kbps at 500 meters).

The Stellaris[®] LM4F231H5QR microcontroller includes two CAN units with the following features:

- CAN protocol version 2.0 part A/B
- Bit rates up to 1 Mbps
- 32 message objects with individual identifier masks
- Maskable interrupt
- Disable Automatic Retransmission mode for Time-Triggered CAN (TTCAN) applications
- Programmable Loopback mode for self-test operation
- Programmable FIFO mode enables storage of multiple message objects
- Gluelessly attaches to an external CAN transceiver through the CAN_nTX and CAN_nRX signals

16.1 Block Diagram

Figure 16-1. CAN Controller Block Diagram

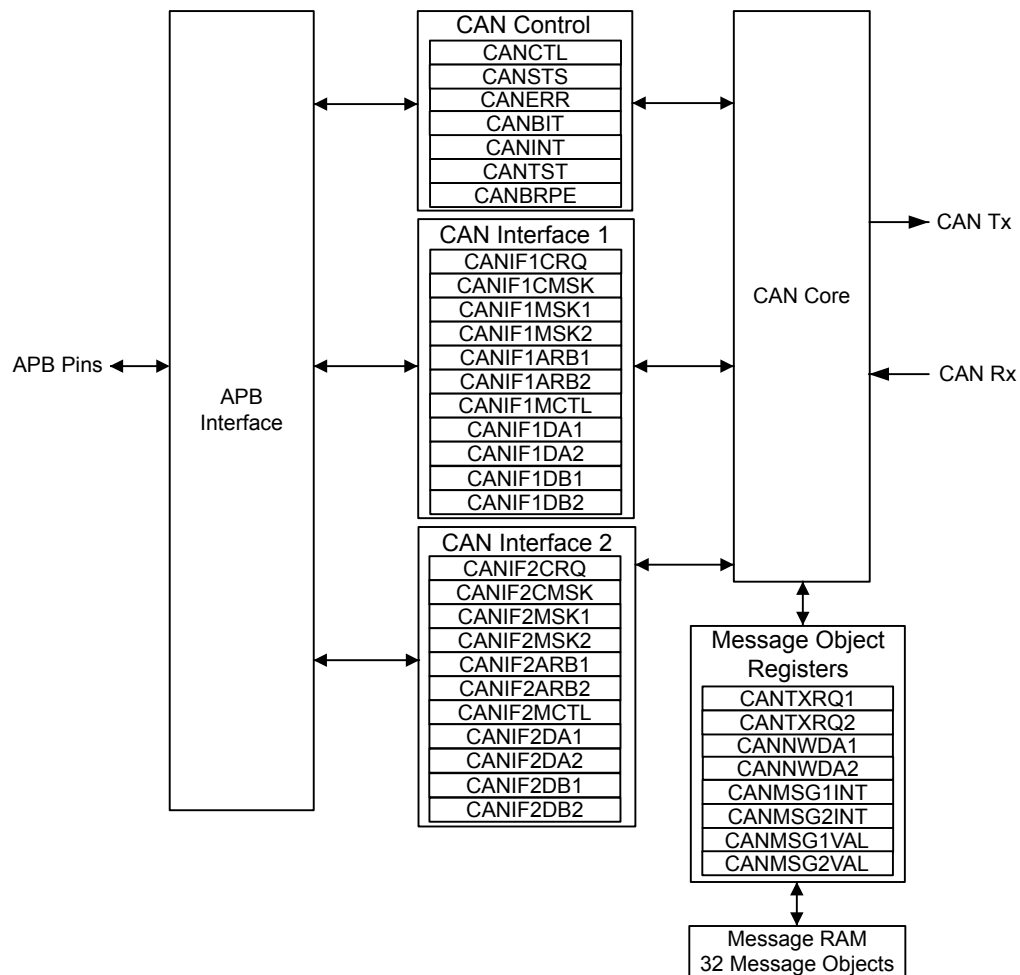

16.2 Signal Description

The following table lists the external signals of the CAN controller and describes the function of each. The CAN controller signals are alternate functions for some GPIO signals and default to be GPIO signals at reset. The column in the table below titled "Pin Mux/Pin Assignment" lists the possible GPIO pin placements for the CAN signals. The `AFSEL` bit in the **GPIO Alternate Function Select (GPIOAFSEL)** register (page 644) should be set to choose the CAN controller function. The number in parentheses is the encoding that must be programmed into the `PMCn` field in the **GPIO Port Control (GPIOCTL)** register (page 661) to assign the CAN signal to the specified GPIO port pin. For more information on configuring GPIOs, see "General-Purpose Input/Outputs (GPIOs)" on page 623.

Table 16-1. Controller Area Network Signals (64LQFP)

Pin Name	Pin Number	Pin Mux / Pin Assignment	Pin Type	Buffer Type ^a	Description
CAN0Rx	28 58 59	PF0 (3) PB4 (8) PE4 (8)	I	TTL	CAN module 0 receive.
CAN0Tx	31 57 60	PF3 (3) PB5 (8) PE5 (8)	O	TTL	CAN module 0 transmit.
CAN1Rx	17	PA0 (8)	I	TTL	CAN module 1 receive.
CAN1Tx	18	PA1 (8)	O	TTL	CAN module 1 transmit.

a. The TTL designation indicates the pin has TTL-compatible voltage levels.

16.3 Functional Description

The Stellaris CAN controller conforms to the CAN protocol version 2.0 (parts A and B). Message transfers that include data, remote, error, and overload frames with an 11-bit identifier (standard) or a 29-bit identifier (extended) are supported. Transfer rates can be programmed up to 1 Mbps.

The CAN module consists of three major parts:

- CAN protocol controller and message handler
- Message memory
- CAN register interface

A data frame contains data for transmission, whereas a remote frame contains no data and is used to request the transmission of a specific message object. The CAN data/remote frame is constructed as shown in Figure 16-2.

Figure 16-2. CAN Data/Remote Frame

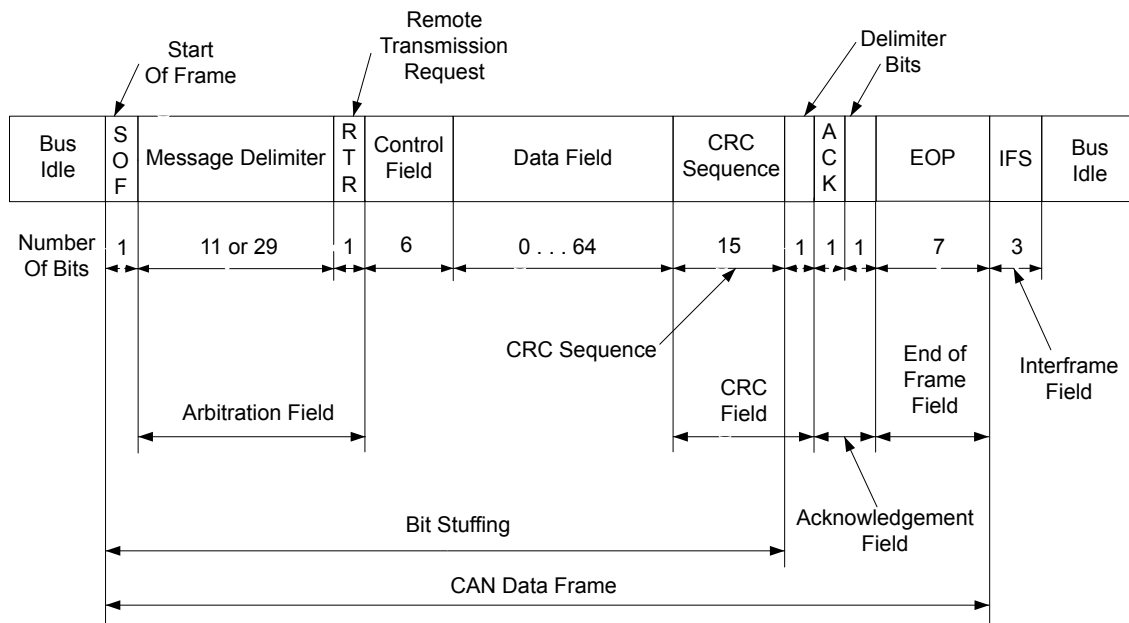

The protocol controller transfers and receives the serial data from the CAN bus and passes the data on to the message handler. The message handler then loads this information into the appropriate message object based on the current filtering and identifiers in the message object memory. The message handler is also responsible for generating interrupts based on events on the CAN bus.

The message object memory is a set of 32 identical memory blocks that hold the current configuration, status, and actual data for each message object. These memory blocks are accessed via either of the CAN message object register interfaces.

The message memory is not directly accessible in the Stellaris memory map, so the Stellaris CAN controller provides an interface to communicate with the message memory via two CAN interface register sets for communicating with the message objects. The message object memory cannot be directly accessed, so these two interfaces must be used to read or write to each message object. The two message object interfaces allow parallel access to the CAN controller message objects when multiple objects may have new information that must be processed. In general, one interface is used for transmit data and one for receive data.

16.3.1 Initialization

To use the CAN controller, the peripheral clock must be enabled using the **RCGC0** register (see page 463). In addition, the clock to the appropriate GPIO module must be enabled via the **RCGC2** register (see page 471). To find out which GPIO port to enable, refer to Table 22-4 on page 1307. Set the GPIO **AFSEL** bits for the appropriate pins (see page 644). Configure the **PMCn** fields in the **GPIOPCTL** register to assign the CAN signals to the appropriate pins. See page 661 and Table 22-5 on page 1314.

Software initialization is started by setting the **INIT** bit in the **CAN Control (CANCTL)** register (with software or by a hardware reset) or by going bus-off, which occurs when the transmitter's error counter exceeds a count of 255. While **INIT** is set, all message transfers to and from the CAN bus are stopped and the **CANnTX** signal is held High. Entering the initialization state does not change the configuration of the CAN controller, the message objects, or the error counters. However, some configuration registers are only accessible while in the initialization state.

To initialize the CAN controller, set the **CAN Bit Timing (CANBIT)** register and configure each message object. If a message object is not needed, label it as not valid by clearing the **MSGVAL** bit in the **CAN IFn Arbitration 2 (CANIFnARB2)** register. Otherwise, the whole message object must be initialized, as the fields of the message object may not have valid information, causing unexpected results. Both the **INIT** and **CCE** bits in the **CANCTL** register must be set in order to access the **CANBIT** register and the **CAN Baud Rate Prescaler Extension (CANBRPE)** register to configure the bit timing. To leave the initialization state, the **INIT** bit must be cleared. Afterwards, the internal Bit Stream Processor (BSP) synchronizes itself to the data transfer on the CAN bus by waiting for the occurrence of a sequence of 11 consecutive recessive bits (indicating a bus idle condition) before it takes part in bus activities and starts message transfers. Message object initialization does not require the CAN to be in the initialization state and can be done on the fly. However, message objects should all be configured to particular identifiers or set to not valid before message transfer starts. To change the configuration of a message object during normal operation, clear the **MSGVAL** bit in the **CANIFnARB2** register to indicate that the message object is not valid during the change. When the configuration is completed, set the **MSGVAL** bit again to indicate that the message object is once again valid.

16.3.2 Operation

Two sets of CAN Interface Registers (**CANIF1x** and **CANIF2x**) are used to access the message objects in the Message RAM. The CAN controller coordinates transfers to and from the Message RAM to and from the registers. The two sets are independent and identical and can be used to

queue transactions. Generally, one interface is used to transmit data and one is used to receive data.

Once the CAN module is initialized and the `INIT` bit in the **CANCTL** register is cleared, the CAN module synchronizes itself to the CAN bus and starts the message transfer. As each message is received, it goes through the message handler's filtering process, and if it passes through the filter, is stored in the message object specified by the `MNUM` bit in the **CAN IFn Command Request (CANIFnCRQ)** register. The whole message (including all arbitration bits, data-length code, and eight data bytes) is stored in the message object. If the Identifier Mask (the `MSK` bits in the **CAN IFn Mask 1** and **CAN IFn Mask 2 (CANIFnMSKn)** registers) is used, the arbitration bits that are masked to "don't care" may be overwritten in the message object.

The CPU may read or write each message at any time via the CAN Interface Registers. The message handler guarantees data consistency in case of concurrent accesses.

The transmission of message objects is under the control of the software that is managing the CAN hardware. Message objects can be used for one-time data transfers or can be permanent message objects used to respond in a more periodic manner. Permanent message objects have all arbitration and control set up, and only the data bytes are updated. At the start of transmission, the appropriate `TXRQST` bit in the **CAN Transmission Request n (CANTXRQn)** register and the `NEWDAT` bit in the **CAN New Data n (CANNWDAn)** register are set. If several transmit messages are assigned to the same message object (when the number of message objects is not sufficient), the whole message object has to be configured before the transmission of this message is requested.

The transmission of any number of message objects may be requested at the same time; they are transmitted according to their internal priority, which is based on the message identifier (`MNUM`) for the message object, with 1 being the highest priority and 32 being the lowest priority. Messages may be updated or set to not valid any time, even when their requested transmission is still pending. The old data is discarded when a message is updated before its pending transmission has started. Depending on the configuration of the message object, the transmission of a message may be requested autonomously by the reception of a remote frame with a matching identifier.

Transmission can be automatically started by the reception of a matching remote frame. To enable this mode, set the `RMTEEN` bit in the **CAN IFn Message Control (CANIFnMCTL)** register. A matching received remote frame causes the `TXRQST` bit to be set, and the message object automatically transfers its data or generates an interrupt indicating a remote frame was requested. A remote frame can be strictly a single message identifier, or it can be a range of values specified in the message object. The CAN mask registers, **CANIFnMSKn**, configure which groups of frames are identified as remote frame requests. The `UMASK` bit in the **CANIFnMCTL** register enables the `MSK` bits in the **CANIFnMSKn** register to filter which frames are identified as a remote frame request. The `MXTD` bit in the **CANIFnMSK2** register should be set if a remote frame request is expected to be triggered by 29-bit extended identifiers.

16.3.3 Transmitting Message Objects

If the internal transmit shift register of the CAN module is ready for loading, and if a data transfer is not occurring between the CAN Interface Registers and message RAM, the valid message object with the highest priority that has a pending transmission request is loaded into the transmit shift register by the message handler and the transmission is started. The message object's `NEWDAT` bit in the **CANNWDAn** register is cleared. After a successful transmission, and if no new data was written to the message object since the start of the transmission, the `TXRQST` bit in the **CANTXRQn** register is cleared. If the CAN controller is configured to interrupt on a successful transmission of a message object, (the `TXIE` bit in the **CAN IFn Message Control (CANIFnMCTL)** register is set), the `INTPND` bit in the **CANIFnMCTL** register is set after a successful transmission. If the CAN module has lost the arbitration or if an error occurred during the transmission, the message is

re-transmitted as soon as the CAN bus is free again. If, meanwhile, the transmission of a message with higher priority has been requested, the messages are transmitted in the order of their priority.

16.3.4 Configuring a Transmit Message Object

The following steps illustrate how to configure a transmit message object.

1. In the **CAN IFn Command Mask (CANIFnCMASK)** register:
 - Set the `WRNRD` bit to specify a write to the **CANIFnCMASK** register; specify whether to transfer the `IDMASK`, `DIR`, and `MXTD` of the message object into the **CAN IFn** registers using the `MASK` bit
 - Specify whether to transfer the `ID`, `DIR`, `XTD`, and `MSGVAL` of the message object into the interface registers using the `ARB` bit
 - Specify whether to transfer the control bits into the interface registers using the `CONTROL` bit
 - Specify whether to clear the `INTPND` bit in the **CANIFnMCTL** register using the `CLRINTPND` bit
 - Specify whether to clear the `NEWDAT` bit in the **CANNWDAn** register using the `NEWDAT` bit
 - Specify which bits to transfer using the `DATAA` and `DATAB` bits
2. In the **CANIFnMSK1** register, use the `MSK[15:0]` bits to specify which of the bits in the 29-bit or 11-bit message identifier are used for acceptance filtering. Note that `MSK[15:0]` in this register are used for bits [15:0] of the 29-bit message identifier and are not used for an 11-bit identifier. A value of 0x00 enables all messages to pass through the acceptance filtering. Also note that in order for these bits to be used for acceptance filtering, they must be enabled by setting the `UMASK` bit in the **CANIFnMCTL** register.
3. In the **CANIFnMSK2** register, use the `MSK[12:0]` bits to specify which of the bits in the 29-bit or 11-bit message identifier are used for acceptance filtering. Note that `MSK[12:0]` are used for bits [28:16] of the 29-bit message identifier; whereas `MSK[12:2]` are used for bits [10:0] of the 11-bit message identifier. Use the `MXTD` and `MDIR` bits to specify whether to use `XTD` and `DIR` for acceptance filtering. A value of 0x00 enables all messages to pass through the acceptance filtering. Also note that in order for these bits to be used for acceptance filtering, they must be enabled by setting the `UMASK` bit in the **CANIFnMCTL** register.
4. For a 29-bit identifier, configure `ID[15:0]` in the **CANIFnARB1** register for bits [15:0] of the message identifier and `ID[12:0]` in the **CANIFnARB2** register for bits [28:16] of the message identifier. Set the `XTD` bit to indicate an extended identifier; set the `DIR` bit to indicate transmit; and set the `MSGVAL` bit to indicate that the message object is valid.
5. For an 11-bit identifier, disregard the **CANIFnARB1** register and configure `ID[12:2]` in the **CANIFnARB2** register for bits [10:0] of the message identifier. Clear the `XTD` bit to indicate a standard identifier; set the `DIR` bit to indicate transmit; and set the `MSGVAL` bit to indicate that the message object is valid.
6. In the **CANIFnMCTL** register:

- Optionally set the `UMASK` bit to enable the mask (`MSK`, `MXTD`, and `MDIR` specified in the **CANIFnMSK1** and **CANIFnMSK2** registers) for acceptance filtering
 - Optionally set the `TXIE` bit to enable the `INTPND` bit to be set after a successful transmission
 - Optionally set the `RMTEN` bit to enable the `TXRQST` bit to be set on the reception of a matching remote frame allowing automatic transmission
 - Set the `EOB` bit for a single message object
 - Configure the `DLC[3:0]` field to specify the size of the data frame. Take care during this configuration not to set the `NEWDAT`, `MSGLST`, `INTPND` or `TXRQST` bits.
7. Load the data to be transmitted into the **CAN IFn Data (CANIFnDA1, CANIFnDA2, CANIFnDB1, CANIFnDB2)** registers. Byte 0 of the CAN data frame is stored in `DATA[7:0]` in the **CANIFnDA1** register.
 8. Program the number of the message object to be transmitted in the `MNUM` field in the **CAN IFn Command Request (CANIFnCRQ)** register.
 9. When everything is properly configured, set the `TXRQST` bit in the **CANIFnMCTL** register. Once this bit is set, the message object is available to be transmitted, depending on priority and bus availability. Note that setting the `RMTEN` bit in the **CANIFnMCTL** register can also start message transmission if a matching remote frame has been received.

16.3.5 Updating a Transmit Message Object

The CPU may update the data bytes of a Transmit Message Object any time via the CAN Interface Registers and neither the `MSGVAL` bit in the **CANIFnARB2** register nor the `TXRQST` bits in the **CANIFnMCTL** register have to be cleared before the update.

Even if only some of the data bytes are to be updated, all four bytes of the corresponding **CANIFnDAn/CANIFnDBn** register have to be valid before the content of that register is transferred to the message object. Either the CPU must write all four bytes into the **CANIFnDAn/CANIFnDBn** register or the message object is transferred to the **CANIFnDAn/CANIFnDBn** register before the CPU writes the new data bytes.

In order to only update the data in a message object, the `WRNRD`, `DATAA` and `DATAB` bits in the **CANIFnMSKn** register are set, followed by writing the updated data into **CANIFnDA1**, **CANIFnDA2**, **CANIFnDB1**, and **CANIFnDB2** registers, and then the number of the message object is written to the `MNUM` field in the **CAN IFn Command Request (CANIFnCRQ)** register. To begin transmission of the new data as soon as possible, set the `TXRQST` bit in the **CANIFnMSKn** register.

To prevent the clearing of the `TXRQST` bit in the **CANIFnMCTL** register at the end of a transmission that may already be in progress while the data is updated, the `NEWDAT` and `TXRQST` bits have to be set at the same time in the **CANIFnMCTL** register. When these bits are set at the same time, `NEWDAT` is cleared as soon as the new transmission has started.

16.3.6 Accepting Received Message Objects

When the arbitration and control field (the `ID` and `XTD` bits in the **CANIFnARB2** and the `RMTEN` and `DLC[3:0]` bits of the **CANIFnMCTL** register) of an incoming message is completely shifted into the CAN controller, the message handling capability of the controller starts scanning the message RAM for a matching valid message object. To scan the message RAM for a matching message object, the controller uses the acceptance filtering programmed through the mask bits in the **CANIFnMSKn** register and enabled using the `UMASK` bit in the **CANIFnMCTL** register. Each valid

message object, starting with object 1, is compared with the incoming message to locate a matching message object in the message RAM. If a match occurs, the scanning is stopped and the message handler proceeds depending on whether it is a data frame or remote frame that was received.

16.3.7 Receiving a Data Frame

The message handler stores the message from the CAN controller receive shift register into the matching message object in the message RAM. The data bytes, all arbitration bits, and the DLC bits are all stored into the corresponding message object. In this manner, the data bytes are connected with the identifier even if arbitration masks are used. The **NEWDAT** bit of the **CANIFnMCTL** register is set to indicate that new data has been received. The CPU should clear this bit when it reads the message object to indicate to the controller that the message has been received, and the buffer is free to receive more messages. If the CAN controller receives a message and the **NEWDAT** bit is already set, the **MSGLST** bit in the **CANIFnMCTL** register is set to indicate that the previous data was lost. If the system requires an interrupt on successful reception of a frame, the **RXIE** bit of the **CANIFnMCTL** register should be set. In this case, the **INTPND** bit of the same register is set, causing the **CANINT** register to point to the message object that just received a message. The **TXRQST** bit of this message object should be cleared to prevent the transmission of a remote frame.

16.3.8 Receiving a Remote Frame

A remote frame contains no data, but instead specifies which object should be transmitted. When a remote frame is received, three different configurations of the matching message object have to be considered:

Table 16-2. Message Object Configurations

Configuration in CANIFnMCTL	Description
<ul style="list-style-type: none"> ■ DIR = 1 (direction = transmit); programmed in the CANIFnARB2 register ■ RMTEN = 1 (set the TXRQST bit of the CANIFnMCTL register at reception of the frame to enable transmission) ■ UMASK = 1 or 0 	At the reception of a matching remote frame, the TXRQST bit of this message object is set. The rest of the message object remains unchanged, and the controller automatically transfers the data in the message object as soon as possible.
<ul style="list-style-type: none"> ■ DIR = 1 (direction = transmit); programmed in the CANIFnARB2 register ■ RMTEN = 0 (do not change the TXRQST bit of the CANIFnMCTL register at reception of the frame) ■ UMASK = 0 (ignore mask in the CANIFnMSKn register) 	At the reception of a matching remote frame, the TXRQST bit of this message object remains unchanged, and the remote frame is ignored. This remote frame is disabled, the data is not transferred and nothing indicates that the remote frame ever happened.
<ul style="list-style-type: none"> ■ DIR = 1 (direction = transmit); programmed in the CANIFnARB2 register ■ RMTEN = 0 (do not change the TXRQST bit of the CANIFnMCTL register at reception of the frame) ■ UMASK = 1 (use mask (MSK, MXTD, and MDIR in the CANIFnMSKn register) for acceptance filtering) 	At the reception of a matching remote frame, the TXRQST bit of this message object is cleared. The arbitration and control field (ID + XTD + RMTEN + DLC) from the shift register is stored into the message object in the message RAM, and the NEWDAT bit of this message object is set. The data field of the message object remains unchanged; the remote frame is treated similar to a received data frame. This mode is useful for a remote data request from another CAN device for which the Stellaris controller does not have readily available data. The software must fill the data and answer the frame manually.

16.3.9 Receive/Transmit Priority

The receive/transmit priority for the message objects is controlled by the message number. Message object 1 has the highest priority, while message object 32 has the lowest priority. If more than one transmission request is pending, the message objects are transmitted in order based on the message object with the lowest message number. This prioritization is separate from that of the message identifier which is enforced by the CAN bus. As a result, if message object 1 and message object 2 both have valid messages to be transmitted, message object 1 is always transmitted first regardless of the message identifier in the message object itself.

16.3.10 Configuring a Receive Message Object

The following steps illustrate how to configure a receive message object.

1. Program the **CAN IFn Command Mask (CANIFnCMASK)** register as described in the “Configuring a Transmit Message Object” on page 1013 section, except that the **WRNRD** bit is set to specify a write to the message RAM.
2. Program the **CANIFnMSK1** and **CANIFnMSK2** registers as described in the “Configuring a Transmit Message Object” on page 1013 section to configure which bits are used for acceptance filtering. Note that in order for these bits to be used for acceptance filtering, they must be enabled by setting the **UMASK** bit in the **CANIFnMCTL** register.
3. In the **CANIFnMSK2** register, use the **MSK[12:0]** bits to specify which of the bits in the 29-bit or 11-bit message identifier are used for acceptance filtering. Note that **MSK[12:0]** are used for bits [28:16] of the 29-bit message identifier; whereas **MSK[12:2]** are used for bits [10:0] of the 11-bit message identifier. Use the **MXTD** and **MDIR** bits to specify whether to use **XTD** and **DIR** for acceptance filtering. A value of 0x00 enables all messages to pass through the acceptance filtering. Also note that in order for these bits to be used for acceptance filtering, they must be enabled by setting the **UMASK** bit in the **CANIFnMCTL** register.
4. Program the **CANIFnARB1** and **CANIFnARB2** registers as described in the “Configuring a Transmit Message Object” on page 1013 section to program **XTD** and **ID** bits for the message identifier to be received; set the **MSGVAL** bit to indicate a valid message; and clear the **DIR** bit to specify receive.
5. In the **CANIFnMCTL** register:
 - Optionally set the **UMASK** bit to enable the mask (**MSK**, **MXTD**, and **MDIR** specified in the **CANIFnMSK1** and **CANIFnMSK2** registers) for acceptance filtering
 - Optionally set the **RXIE** bit to enable the **INTPND** bit to be set after a successful reception
 - Clear the **RMTEN** bit to leave the **TXRQST** bit unchanged
 - Set the **EOB** bit for a single message object
 - Configure the **DLC[3:0]** field to specify the size of the data frameTake care during this configuration not to set the **NEWDAT**, **MSGLST**, **INTPND** or **TXRQST** bits.
6. Program the number of the message object to be received in the **MNUM** field in the **CAN IFn Command Request (CANIFnCRQ)** register. Reception of the message object begins as soon as a matching frame is available on the CAN bus.

When the message handler stores a data frame in the message object, it stores the received Data Length Code and eight data bytes in the **CANIFnDA1**, **CANIFnDA2**, **CANIFnDB1**, and **CANIFnDB2** register. Byte 0 of the CAN data frame is stored in `DATA[7:0]` in the **CANIFnDA1** register. If the Data Length Code is less than 8, the remaining bytes of the message object are overwritten by unspecified values.

The CAN mask registers can be used to allow groups of data frames to be received by a message object. The CAN mask registers, **CANIFnMSKn**, configure which groups of frames are received by a message object. The `UMASK` bit in the **CANIFnMCTL** register enables the `MSK` bits in the **CANIFnMSKn** register to filter which frames are received. The `MXTD` bit in the **CANIFnMSK2** register should be set if only 29-bit extended identifiers are expected by this message object.

16.3.11 Handling of Received Message Objects

The CPU may read a received message any time via the CAN Interface registers because the data consistency is guaranteed by the message handler state machine.

Typically, the CPU first writes 0x007F to the **CANIFnCMSK** register and then writes the number of the message object to the **CANIFnCRQ** register. That combination transfers the whole received message from the message RAM into the Message Buffer registers (**CANIFnMSKn**, **CANIFnARBn**, and **CANIFnMCTL**). Additionally, the `NEWDAT` and `INTPND` bits are cleared in the message RAM, acknowledging that the message has been read and clearing the pending interrupt generated by this message object.

If the message object uses masks for acceptance filtering, the **CANIFnARBn** registers show the full, unmasked ID for the received message.

The `NEWDAT` bit in the **CANIFnMCTL** register shows whether a new message has been received since the last time this message object was read. The `MSGLST` bit in the **CANIFnMCTL** register shows whether more than one message has been received since the last time this message object was read. `MSGLST` is not automatically cleared, and should be cleared by software after reading its status.

Using a remote frame, the CPU may request new data from another CAN node on the CAN bus. Setting the `TXRQST` bit of a receive object causes the transmission of a remote frame with the receive object's identifier. This remote frame triggers the other CAN node to start the transmission of the matching data frame. If the matching data frame is received before the remote frame could be transmitted, the `TXRQST` bit is automatically reset. This prevents the possible loss of data when the other device on the CAN bus has already transmitted the data slightly earlier than expected.

16.3.11.1 Configuration of a FIFO Buffer

With the exception of the `EOB` bit in the **CANIFnMCTL** register, the configuration of receive message objects belonging to a FIFO buffer is the same as the configuration of a single receive message object (see “Configuring a Receive Message Object” on page 1016). To concatenate two or more message objects into a FIFO buffer, the identifiers and masks (if used) of these message objects have to be programmed to matching values. Due to the implicit priority of the message objects, the message object with the lowest message object number is the first message object in a FIFO buffer. The `EOB` bit of all message objects of a FIFO buffer except the last one must be cleared. The `EOB` bit of the last message object of a FIFO buffer is set, indicating it is the last entry in the buffer.

16.3.11.2 Reception of Messages with FIFO Buffers

Received messages with identifiers matching to a FIFO buffer are stored starting with the message object with the lowest message number. When a message is stored into a message object of a FIFO buffer, the `NEWDAT` of the **CANIFnMCTL** register bit of this message object is set. By setting

NEWDAT while EOB is clear, the message object is locked and cannot be written to by the message handler until the CPU has cleared the NEWDAT bit. Messages are stored into a FIFO buffer until the last message object of this FIFO buffer is reached. Until all of the preceding message objects have been released by clearing the NEWDAT bit, all further messages for this FIFO buffer are written into the last message object of the FIFO buffer and therefore overwrite previous messages.

16.3.11.3 Reading from a FIFO Buffer

When the CPU transfers the contents of a message object from a FIFO buffer by writing its number to the **CANIFnCRQ** register, the **TXRQST** and **CLRINTPND** bits in the **CANIFnCMSK** register should be set such that the **NEWDAT** and **INTPEND** bits in the **CANIFnMCTL** register are cleared after the read. The values of these bits in the **CANIFnMCTL** register always reflect the status of the message object before the bits are cleared. To assure the correct function of a FIFO buffer, the CPU should read out the message objects starting with the message object with the lowest message number. When reading from the FIFO buffer, the user should be aware that a new received message is placed in the message object with the lowest message number for which the **NEWDAT** bit of the **CANIFnMCTL** register is clear. As a result, the order of the received messages in the FIFO is not guaranteed. Figure 16-3 on page 1019 shows how a set of message objects which are concatenated to a FIFO Buffer can be handled by the CPU.

Figure 16-3. Message Objects in a FIFO Buffer

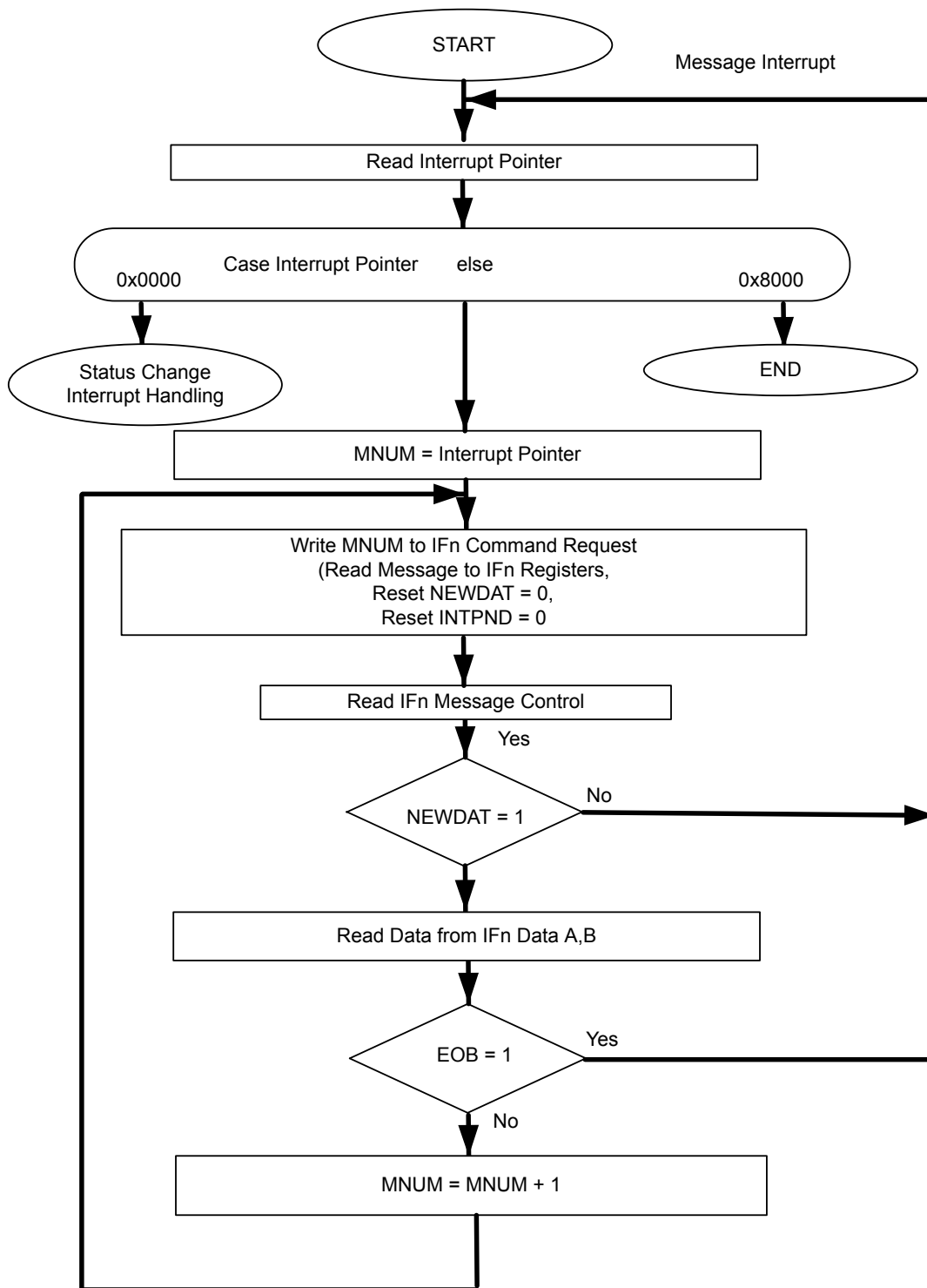

16.3.12 Handling of Interrupts

If several interrupts are pending, the **CAN Interrupt (CANINT)** register points to the pending interrupt with the highest priority, disregarding their chronological order. The status interrupt has the highest

priority. Among the message interrupts, the message object's interrupt with the lowest message number has the highest priority. A message interrupt is cleared by clearing the message object's `INTPND` bit in the `CANIFnMCTL` register or by reading the **CAN Status (CANSTS)** register. The status Interrupt is cleared by reading the **CANSTS** register.

The interrupt identifier `INTID` in the **CANINT** register indicates the cause of the interrupt. When no interrupt is pending, the register reads as `0x0000`. If the value of the `INTID` field is different from 0, then an interrupt is pending. If the `IE` bit is set in the **CANCTL** register, the interrupt line to the interrupt controller is active. The interrupt line remains active until the `INTID` field is 0, meaning that all interrupt sources have been cleared (the cause of the interrupt is reset), or until `IE` is cleared, which disables interrupts from the CAN controller.

The `INTID` field of the **CANINT** register points to the pending message interrupt with the highest interrupt priority. The `SIE` bit in the **CANCTL** register controls whether a change of the `RXOK`, `TXOK`, and `LEC` bits in the **CANSTS** register can cause an interrupt. The `EIE` bit in the **CANCTL** register controls whether a change of the `BOFF` and `EWARN` bits in the **CANSTS** register can cause an interrupt. The `IE` bit in the **CANCTL** register controls whether any interrupt from the CAN controller actually generates an interrupt to the interrupt controller. The **CANINT** register is updated even when the `IE` bit in the **CANCTL** register is clear, but the interrupt is not indicated to the CPU.

A value of `0x8000` in the **CANINT** register indicates that an interrupt is pending because the CAN module has updated, but not necessarily changed, the **CANSTS** register, indicating that either an error or status interrupt has been generated. A write access to the **CANSTS** register can clear the `RXOK`, `TXOK`, and `LEC` bits in that same register; however, the only way to clear the source of a status interrupt is to read the **CANSTS** register.

The source of an interrupt can be determined in two ways during interrupt handling. The first is to read the `INTID` bit in the **CANINT** register to determine the highest priority interrupt that is pending, and the second is to read the **CAN Message Interrupt Pending (CANMSGnINT)** register to see all of the message objects that have pending interrupts.

An interrupt service routine reading the message that is the source of the interrupt may read the message and clear the message object's `INTPND` bit at the same time by setting the `CLRINTPND` bit in the **CANIFnCMSK** register. Once the `INTPND` bit has been cleared, the **CANINT** register contains the message number for the next message object with a pending interrupt.

16.3.13 Test Mode

A Test Mode is provided which allows various diagnostics to be performed. Test Mode is entered by setting the `TEST` bit in the **CANCTL** register. Once in Test Mode, the `TX[1:0]`, `LBACK`, `SILENT` and `BASIC` bits in the **CAN Test (CANTST)** register can be used to put the CAN controller into the various diagnostic modes. The `RX` bit in the **CANTST** register allows monitoring of the `CANnRX` signal. All **CANTST** register functions are disabled when the `TEST` bit is cleared.

16.3.13.1 Silent Mode

Silent Mode can be used to analyze the traffic on a CAN bus without affecting it by the transmission of dominant bits (Acknowledge Bits, Error Frames). The CAN Controller is put in Silent Mode setting the `SILENT` bit in the **CANTST** register. In Silent Mode, the CAN controller is able to receive valid data frames and valid remote frames, but it sends only recessive bits on the CAN bus and cannot start a transmission. If the CAN Controller is required to send a dominant bit (ACK bit, overload flag, or active error flag), the bit is rerouted internally so that the CAN Controller monitors this dominant bit, although the CAN bus remains in recessive state.

16.3.13.2 Loopback Mode

Loopback mode is useful for self-test functions. In Loopback Mode, the CAN Controller internally routes the CAN_nTX signal on to the CAN_nRX signal and treats its own transmitted messages as received messages and stores them (if they pass acceptance filtering) into the message buffer. The CAN Controller is put in Loopback Mode by setting the LBACK bit in the CANTST register. To be independent from external stimulation, the CAN Controller ignores acknowledge errors (a recessive bit sampled in the acknowledge slot of a data/remote frame) in Loopback Mode. The actual value of the CAN_nRX signal is disregarded by the CAN Controller. The transmitted messages can be monitored on the CAN_nTX signal.

16.3.13.3 Loopback Combined with Silent Mode

Loopback Mode and Silent Mode can be combined to allow the CAN Controller to be tested without affecting a running CAN system connected to the CAN_nTX and CAN_nRX signals. In this mode, the CAN_nRX signal is disconnected from the CAN Controller and the CAN_nTX signal is held recessive. This mode is enabled by setting both the LBACK and SILENT bits in the CANTST register.

16.3.13.4 Basic Mode

Basic Mode allows the CAN Controller to be operated without the Message RAM. In Basic Mode, The CANIF1 registers are used as the transmit buffer. The transmission of the contents of the IF1 registers is requested by setting the BUSY bit of the CANIF1CRQ register. The CANIF1 registers are locked while the BUSY bit is set. The BUSY bit indicates that a transmission is pending. As soon the CAN bus is idle, the CANIF1 registers are loaded into the shift register of the CAN Controller and transmission is started. When the transmission has completed, the BUSY bit is cleared and the locked CANIF1 registers are released. A pending transmission can be aborted at any time by clearing the BUSY bit in the CANIF1CRQ register while the CANIF1 registers are locked. If the CPU has cleared the BUSY bit, a possible retransmission in case of lost arbitration or an error is disabled.

The CANIF2 Registers are used as a receive buffer. After the reception of a message, the contents of the shift register are stored in the CANIF2 registers, without any acceptance filtering. Additionally, the actual contents of the shift register can be monitored during the message transfer. Each time a read message object is initiated by setting the BUSY bit of the CANIF2CRQ register, the contents of the shift register are stored into the CANIF2 registers.

In Basic Mode, all message-object-related control and status bits and of the control bits of the CANIF_nCMSK registers are not evaluated. The message number of the CANIF_nCRQ registers is also not evaluated. In the CANIF2MCTL register, the NEWDAT and MSGLSST bits retain their function, the DLC[3:0] field shows the received DLC, the other control bits are cleared.

Basic Mode is enabled by setting the BASIC bit in the CANTST register.

16.3.13.5 Transmit Control

Software can directly override control of the CAN_nTX signal in four different ways.

- CAN_nTX is controlled by the CAN Controller
- The sample point is driven on the CAN_nTX signal to monitor the bit timing
- CAN_nTX drives a low value
- CAN_nTX drives a high value

The last two functions, combined with the readable CAN receive pin `CANnRX`, can be used to check the physical layer of the CAN bus.

The Transmit Control function is enabled by programming the `TX[1:0]` field in the **CANTST** register. The three test functions for the `CANnTX` signal interfere with all CAN protocol functions. `TX[1:0]` must be cleared when CAN message transfer or Loopback Mode, Silent Mode, or Basic Mode are selected.

16.3.14 Bit Timing Configuration Error Considerations

Even if minor errors in the configuration of the CAN bit timing do not result in immediate failure, the performance of a CAN network can be reduced significantly. In many cases, the CAN bit synchronization amends a faulty configuration of the CAN bit timing to such a degree that only occasionally an error frame is generated. In the case of arbitration, however, when two or more CAN nodes simultaneously try to transmit a frame, a misplaced sample point may cause one of the transmitters to become error passive. The analysis of such sporadic errors requires a detailed knowledge of the CAN bit synchronization inside a CAN node and of the CAN nodes' interaction on the CAN bus.

16.3.15 Bit Time and Bit Rate

The CAN system supports bit rates in the range of lower than 1 Kbps up to 1000 Kbps. Each member of the CAN network has its own clock generator. The timing parameter of the bit time can be configured individually for each CAN node, creating a common bit rate even though the CAN nodes' oscillator periods may be different.

Because of small variations in frequency caused by changes in temperature or voltage and by deteriorating components, these oscillators are not absolutely stable. As long as the variations remain inside a specific oscillator's tolerance range, the CAN nodes are able to compensate for the different bit rates by periodically resynchronizing to the bit stream.

According to the CAN specification, the bit time is divided into four segments (see Figure 16-4 on page 1023): the Synchronization Segment, the Propagation Time Segment, the Phase Buffer Segment 1, and the Phase Buffer Segment 2. Each segment consists of a specific, programmable number of time quanta (see Table 16-3 on page 1023). The length of the time quantum (t_q), which is the basic time unit of the bit time, is defined by the CAN controller's input clock (f_{sys}) and the Baud Rate Prescaler (**BRP**):

$$t_q = BRP / f_{sys}$$

The f_{sys} input clock is the system clock frequency as configured by the **RCC** or **RCC2** registers (see page 249 or page 256).

The Synchronization Segment Sync is that part of the bit time where edges of the CAN bus level are expected to occur; the distance between an edge that occurs outside of `Sync` and the `Sync` is called the phase error of that edge.

The Propagation Time Segment Prop is intended to compensate for the physical delay times within the CAN network.

The Phase Buffer Segments Phase1 and Phase2 surround the Sample Point.

The (Re-)Synchronization Jump Width (SJW) defines how far a resynchronization may move the Sample Point inside the limits defined by the Phase Buffer Segments to compensate for edge phase errors.

A given bit rate may be met by different bit-time configurations, but for the proper function of the CAN network, the physical delay times and the oscillator's tolerance range have to be considered.

Figure 16-4. CAN Bit Time

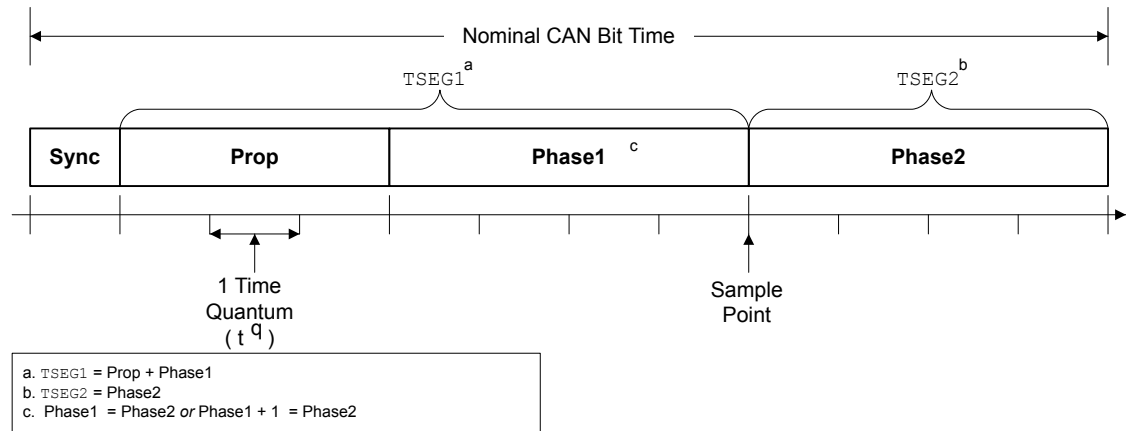
Table 16-3. CAN Protocol Ranges^a

Parameter	Range	Remark
BRP	[1 .. 64]	Defines the length of the time quantum t_q . The CANBRPE register can be used to extend the range to 1024.
Sync	1 t_q	Fixed length, synchronization of bus input to system clock
Prop	[1 .. 8] t_q	Compensates for the physical delay times
Phase1	[1 .. 8] t_q	May be lengthened temporarily by synchronization
Phase2	[1 .. 8] t_q	May be shortened temporarily by synchronization
SJW	[1 .. 4] t_q	May not be longer than either Phase Buffer Segment

a. This table describes the minimum programmable ranges required by the CAN protocol.

The bit timing configuration is programmed in two register bytes in the **CANBIT** register. In the **CANBIT** register, the four components TSEG2, TSEG1, SJW, and BRP have to be programmed to a numerical value that is one less than its functional value; so instead of values in the range of [1..n], values in the range of [0..n-1] are programmed. That way, for example, SJW (functional range of [1..4]) is represented by only two bits in the SJW bit field. Table 16-4 shows the relationship between the **CANBIT** register values and the parameters.

Table 16-4. CANBIT Register Values

CANBIT Register Field	Setting
TSEG2	Phase2 - 1
TSEG1	Prop + Phase1 - 1
SJW	SJW - 1
BRP	BRP

Therefore, the length of the bit time is (programmed values):

$$[TSEG1 + TSEG2 + 3] \times t_q$$

or (functional values):

$$[Sync + Prop + Phase1 + Phase2] \times t_q$$

The data in the **CANBIT** register is the configuration input of the CAN protocol controller. The baud rate prescaler (configured by the BRP field) defines the length of the time quantum, the basic time

unit of the bit time; the bit timing logic (configured by TSEG1, TSEG2, and SJW) defines the number of time quanta in the bit time.

The processing of the bit time, the calculation of the position of the sample point, and occasional synchronizations are controlled by the CAN controller and are evaluated once per time quantum.

The CAN controller translates messages to and from frames. In addition, the controller generates and discards the enclosing fixed format bits, inserts and extracts stuff bits, calculates and checks the CRC code, performs the error management, and decides which type of synchronization is to be used. The bit value is received or transmitted at the sample point. The information processing time (IPT) is the time after the sample point needed to calculate the next bit to be transmitted on the CAN bus. The IPT includes any of the following: retrieving the next data bit, handling a CRC bit, determining if bit stuffing is required, generating an error flag or simply going idle.

The IPT is application-specific but may not be longer than $2 t_q$; the CAN's IPT is $0 t_q$. Its length is the lower limit of the programmed length of Phase2. In case of synchronization, Phase2 may be shortened to a value less than IPT, which does not affect bus timing.

16.3.16 Calculating the Bit Timing Parameters

Usually, the calculation of the bit timing configuration starts with a required bit rate or bit time. The resulting bit time (1/bit rate) must be an integer multiple of the system clock period.

The bit time may consist of 4 to 25 time quanta. Several combinations may lead to the required bit time, allowing iterations of the following steps.

The first part of the bit time to be defined is Prop. Its length depends on the delay times measured in the system. A maximum bus length as well as a maximum node delay has to be defined for expandable CAN bus systems. The resulting time for Prop is converted into time quanta (rounded up to the nearest integer multiple of t_q).

Sync is $1 t_q$ long (fixed), which leaves $(\text{bit time} - \text{Prop} - 1) t_q$ for the two Phase Buffer Segments. If the number of remaining t_q is even, the Phase Buffer Segments have the same length, that is, Phase2 = Phase1, else Phase2 = Phase1 + 1.

The minimum nominal length of Phase2 has to be regarded as well. Phase2 may not be shorter than the CAN controller's Information Processing Time, which is, depending on the actual implementation, in the range of $[0..2] t_q$.

The length of the synchronization jump width is set to the least of 4, Phase1 or Phase2.

The oscillator tolerance range necessary for the resulting configuration is calculated by the formula given below:

$$(1 - df) \times f_{nom} \leq f_{osc} \leq (1 + df) \times f_{nom}$$

where:

- df = Maximum tolerance of oscillator frequency
- f_{osc} = Actual oscillator frequency
- f_{nom} = Nominal oscillator frequency

Maximum frequency tolerance must take into account the following formulas:

$$df \leq \frac{(Phase_seg1, Phase_seg2) \min}{2 \times (13 \times t_{bit} - Phase_Seg2)}$$

$$df \max = 2 \times df \times f_{nom}$$

where:

- Phase1 and Phase2 are from Table 16-3 on page 1023
- t_{bit} = Bit Time
- df_{max} = Maximum difference between two oscillators

If more than one configuration is possible, that configuration allowing the highest oscillator tolerance range should be chosen.

CAN nodes with different system clocks require different configurations to come to the same bit rate. The calculation of the propagation time in the CAN network, based on the nodes with the longest delay times, is done once for the whole network.

The CAN system's oscillator tolerance range is limited by the node with the lowest tolerance range.

The calculation may show that bus length or bit rate have to be decreased or that the oscillator frequencies' stability has to be increased in order to find a protocol-compliant configuration of the CAN bit timing.

16.3.16.1 Example for Bit Timing at High Baud Rate

In this example, the frequency of CAN clock is 25 MHz, and the bit rate is 1 Mbps.

$$\text{bit time} = 1 \mu\text{s} = n * t_q = 5 * t_q$$

$$t_q = 200 \text{ ns}$$

$$t_q = (\text{Baud rate Prescaler}) / \text{CAN Clock}$$

$$\text{Baud rate Prescaler} = t_q * \text{CAN Clock}$$

$$\text{Baud rate Prescaler} = 200\text{E-9} * 25\text{E6} = 5$$

$$t_{\text{Sync}} = 1 * t_q = 200 \text{ ns}$$

\\fixed at 1 time quanta

delay of bus driver 50 ns

delay of receiver circuit 30 ns

delay of bus line (40m) 220 ns

$$t_{\text{Prop}} 400 \text{ ns} = 2 * t_q$$

\\400 is next integer multiple of t_q

$$\text{bit time} = t_{\text{Sync}} + t_{\text{TSeg1}} + t_{\text{TSeg2}} = 5 * t_q$$

$$\text{bit time} = t_{\text{Sync}} + t_{\text{Prop}} + t_{\text{Phase 1}} + t_{\text{Phase 2}}$$

$$t_{\text{Phase 1}} + t_{\text{Phase 2}} = \text{bit time} - t_{\text{Sync}} - t_{\text{Prop}}$$

$$t_{\text{Phase 1}} + t_{\text{Phase 2}} = (5 * t_q) - (1 * t_q) - (2 * t_q)$$

$$t_{\text{Phase 1}} + t_{\text{Phase 2}} = 2 * t_q$$

$$t_{\text{Phase1}} = 1 * t_q$$

$$t_{\text{Phase2}} = 1 * t_q$$

\\tPhase2 = tPhase1

```

tTSeg1 = tProp + tPhase1
tTSeg1 = (2 * tq) + (1 * tq)
tTSeg1 = 3 * tq

tTSeg2 = tPhase2
tTSeg2 = (Information Processing Time + 1) * tq
tTSeg2 = 1 * tq                \\Assumes IPT=0

tSJW = 1 * tq                \\Least of 4, Phase1 and Phase2
    
```

In the above example, the bit field values for the **CANBIT** register are:

TSEG2	= TSeg2 -1 = 1-1 = 0
TSEG1	= TSeg1 -1 = 3-1 = 2
SJW	= SJW -1 = 1-1 = 0
BRP	= Baud rate prescaler - 1 = 5-1 =4

The final value programmed into the **CANBIT** register = 0x0204.

16.3.16.2 Example for Bit Timing at Low Baud Rate

In this example, the frequency of the CAN clock is 50 MHz, and the bit rate is 100 Kbps.

```

bit time = 10 μs = n * tq = 10 * tq
tq = 1 μs
tq = (Baud rate Prescaler)/CAN Clock
Baud rate Prescaler = tq * CAN Clock
Baud rate Prescaler = 1E-6 * 50E6 = 50

tSync = 1 * tq = 1 μs                \\fixed at 1 time quanta

delay of bus driver 200 ns
delay of receiver circuit 80 ns
delay of bus line (40m) 220 ns
tProp 1 μs = 1 * tq                \\1 μs is next integer multiple of tq

bit time = tSync + tTSeg1 + tTSeg2 = 10 * tq
bit time = tSync + tProp + tPhase 1 + tPhase2
tPhase 1 + tPhase2 = bit time - tSync - tProp
tPhase 1 + tPhase2 = (10 * tq) - (1 * tq) - (1 * tq)
tPhase 1 + tPhase2 = 8 * tq
tPhase1 = 4 * tq
tPhase2 = 4 * tq                \\tPhase1 = tPhase2
    
```

$$\begin{aligned}
 tTSeg1 &= tProp + tPhase1 \\
 tTSeg1 &= (1 * t_q) + (4 * t_q) \\
 tTSeg1 &= 5 * t_q \\
 tTSeg2 &= tPhase2 \\
 tTSeg2 &= (\text{Information Processing Time} + 4) * t_q \\
 tTSeg2 &= 4 * t_q \quad \quad \quad \backslash\backslash \text{Assumes IPT}=0 \\
 \\
 tSJW &= 4 * t_q \quad \quad \quad \backslash\backslash \text{Least of 4, Phase1, and Phase2}
 \end{aligned}$$

TSEG2	= TSeg2 -1 = 4-1 = 3
TSEG1	= TSeg1 -1 = 5-1 = 4
SJW	= SJW -1 = 4-1 = 3
BRP	= Baud rate prescaler - 1 = 50-1 =49

The final value programmed into the **CANBIT** register = 0x34F1.

16.4 Register Map

Table 16-5 on page 1027 lists the registers. All addresses given are relative to the CAN base address of:

- CAN0: 0x4004.0000
- CAN1: 0x4004.1000

Note that the CAN controller clock must be enabled before the registers can be programmed (see page 329). There must be a delay of 3 system clocks after the CAN module clock is enabled before any CAN module registers are accessed.

Table 16-5. CAN Register Map

Offset	Name	Type	Reset	Description	See page
0x000	CANCTL	R/W	0x0000.0001	CAN Control	1030
0x004	CANSTS	R/W	0x0000.0000	CAN Status	1032
0x008	CANERR	RO	0x0000.0000	CAN Error Counter	1035
0x00C	CANBIT	R/W	0x0000.2301	CAN Bit Timing	1036
0x010	CANINT	RO	0x0000.0000	CAN Interrupt	1037
0x014	CANTST	R/W	0x0000.0000	CAN Test	1038
0x018	CANBRPE	R/W	0x0000.0000	CAN Baud Rate Prescaler Extension	1040
0x020	CANIF1CRQ	R/W	0x0000.0001	CAN IF1 Command Request	1041

Table 16-5. CAN Register Map (continued)

Offset	Name	Type	Reset	Description	See page
0x024	CANIF1CMSK	R/W	0x0000.0000	CAN IF1 Command Mask	1042
0x028	CANIF1MSK1	R/W	0x0000.FFFF	CAN IF1 Mask 1	1045
0x02C	CANIF1MSK2	R/W	0x0000.FFFF	CAN IF1 Mask 2	1046
0x030	CANIF1ARB1	R/W	0x0000.0000	CAN IF1 Arbitration 1	1048
0x034	CANIF1ARB2	R/W	0x0000.0000	CAN IF1 Arbitration 2	1049
0x038	CANIF1MCTL	R/W	0x0000.0000	CAN IF1 Message Control	1051
0x03C	CANIF1DA1	R/W	0x0000.0000	CAN IF1 Data A1	1054
0x040	CANIF1DA2	R/W	0x0000.0000	CAN IF1 Data A2	1054
0x044	CANIF1DB1	R/W	0x0000.0000	CAN IF1 Data B1	1054
0x048	CANIF1DB2	R/W	0x0000.0000	CAN IF1 Data B2	1054
0x080	CANIF2CRQ	R/W	0x0000.0001	CAN IF2 Command Request	1041
0x084	CANIF2CMSK	R/W	0x0000.0000	CAN IF2 Command Mask	1042
0x088	CANIF2MSK1	R/W	0x0000.FFFF	CAN IF2 Mask 1	1045
0x08C	CANIF2MSK2	R/W	0x0000.FFFF	CAN IF2 Mask 2	1046
0x090	CANIF2ARB1	R/W	0x0000.0000	CAN IF2 Arbitration 1	1048
0x094	CANIF2ARB2	R/W	0x0000.0000	CAN IF2 Arbitration 2	1049
0x098	CANIF2MCTL	R/W	0x0000.0000	CAN IF2 Message Control	1051
0x09C	CANIF2DA1	R/W	0x0000.0000	CAN IF2 Data A1	1054
0x0A0	CANIF2DA2	R/W	0x0000.0000	CAN IF2 Data A2	1054
0x0A4	CANIF2DB1	R/W	0x0000.0000	CAN IF2 Data B1	1054
0x0A8	CANIF2DB2	R/W	0x0000.0000	CAN IF2 Data B2	1054
0x100	CANTXRQ1	RO	0x0000.0000	CAN Transmission Request 1	1055
0x104	CANTXRQ2	RO	0x0000.0000	CAN Transmission Request 2	1055
0x120	CANNWDA1	RO	0x0000.0000	CAN New Data 1	1056
0x124	CANNWDA2	RO	0x0000.0000	CAN New Data 2	1056
0x140	CANMSG1INT	RO	0x0000.0000	CAN Message 1 Interrupt Pending	1057
0x144	CANMSG2INT	RO	0x0000.0000	CAN Message 2 Interrupt Pending	1057
0x160	CANMSG1VAL	RO	0x0000.0000	CAN Message 1 Valid	1058
0x164	CANMSG2VAL	RO	0x0000.0000	CAN Message 2 Valid	1058

16.5 CAN Register Descriptions

The remainder of this section lists and describes the CAN registers, in numerical order by address offset. There are two sets of Interface Registers that are used to access the Message Objects in

the Message RAM: **CANIF1x** and **CANIF2x**. The function of the two sets are identical and are used to queue transactions.

Register 1: CAN Control (CANCTL), offset 0x000

This control register initializes the module and enables test mode and interrupts.

The bus-off recovery sequence (see CAN Specification Rev. 2.0) cannot be shortened by setting or clearing `INIT`. If the device goes bus-off, it sets `INIT`, stopping all bus activities. Once `INIT` has been cleared by the CPU, the device then waits for 129 occurrences of Bus Idle (129 * 11 consecutive High bits) before resuming normal operations. At the end of the bus-off recovery sequence, the Error Management Counters are reset.

During the waiting time after `INIT` is cleared, each time a sequence of 11 High bits has been monitored, a `BITERROR0` code is written to the **CANSTS** register (the `LEC` field = 0x5), enabling the CPU to readily check whether the CAN bus is stuck Low or continuously disturbed, and to monitor the proceeding of the bus-off recovery sequence.

CAN Control (CANCTL)

CAN0 base: 0x4004.0000
 CAN1 base: 0x4004.1000
 Offset 0x000
 Type R/W, reset 0x0000.0001

	31	30	29	28	27	26	25	24	23	22	21	20	19	18	17	16
	reserved															
Type	RO	RO	RO	RO	RO	RO	RO	RO	RO	RO	RO	RO	RO	RO	RO	RO
Reset	0	0	0	0	0	0	0	0	0	0	0	0	0	0	0	0
	15	14	13	12	11	10	9	8	7	6	5	4	3	2	1	0
	reserved								TEST	CCE	DAR	reserved	EIE	SIE	IE	INIT
Type	RO	RO	RO	RO	RO	RO	RO	RO	R/W	R/W	R/W	RO	R/W	R/W	R/W	R/W
Reset	0	0	0	0	0	0	0	0	0	0	0	0	0	0	0	1

Bit/Field	Name	Type	Reset	Description						
31:8	reserved	RO	0x0000.00	Software should not rely on the value of a reserved bit. To provide compatibility with future products, the value of a reserved bit should be preserved across a read-modify-write operation.						
7	TEST	R/W	0	Test Mode Enable						
				<table border="0"> <tr> <td>Value</td> <td>Description</td> </tr> <tr> <td>0</td> <td>The CAN controller is operating normally.</td> </tr> <tr> <td>1</td> <td>The CAN controller is in test mode.</td> </tr> </table>	Value	Description	0	The CAN controller is operating normally.	1	The CAN controller is in test mode.
Value	Description									
0	The CAN controller is operating normally.									
1	The CAN controller is in test mode.									
6	CCE	R/W	0	Configuration Change Enable						
				<table border="0"> <tr> <td>Value</td> <td>Description</td> </tr> <tr> <td>0</td> <td>Write accesses to the CANBIT register are not allowed.</td> </tr> <tr> <td>1</td> <td>Write accesses to the CANBIT register are allowed if the <code>INIT</code> bit is 1.</td> </tr> </table>	Value	Description	0	Write accesses to the CANBIT register are not allowed.	1	Write accesses to the CANBIT register are allowed if the <code>INIT</code> bit is 1.
Value	Description									
0	Write accesses to the CANBIT register are not allowed.									
1	Write accesses to the CANBIT register are allowed if the <code>INIT</code> bit is 1.									
5	DAR	R/W	0	Disable Automatic-Retransmission						
				<table border="0"> <tr> <td>Value</td> <td>Description</td> </tr> <tr> <td>0</td> <td>Auto-retransmission of disturbed messages is enabled.</td> </tr> <tr> <td>1</td> <td>Auto-retransmission is disabled.</td> </tr> </table>	Value	Description	0	Auto-retransmission of disturbed messages is enabled.	1	Auto-retransmission is disabled.
Value	Description									
0	Auto-retransmission of disturbed messages is enabled.									
1	Auto-retransmission is disabled.									

Bit/Field	Name	Type	Reset	Description						
4	reserved	RO	0	Software should not rely on the value of a reserved bit. To provide compatibility with future products, the value of a reserved bit should be preserved across a read-modify-write operation.						
3	EIE	R/W	0	Error Interrupt Enable <table border="1"> <thead> <tr> <th>Value</th> <th>Description</th> </tr> </thead> <tbody> <tr> <td>0</td> <td>No error status interrupt is generated.</td> </tr> <tr> <td>1</td> <td>A change in the <i>BOFF</i> or <i>EWARN</i> bits in the CANSTS register generates an interrupt.</td> </tr> </tbody> </table>	Value	Description	0	No error status interrupt is generated.	1	A change in the <i>BOFF</i> or <i>EWARN</i> bits in the CANSTS register generates an interrupt.
Value	Description									
0	No error status interrupt is generated.									
1	A change in the <i>BOFF</i> or <i>EWARN</i> bits in the CANSTS register generates an interrupt.									
2	SIE	R/W	0	Status Interrupt Enable <table border="1"> <thead> <tr> <th>Value</th> <th>Description</th> </tr> </thead> <tbody> <tr> <td>0</td> <td>No status interrupt is generated.</td> </tr> <tr> <td>1</td> <td>An interrupt is generated when a message has successfully been transmitted or received, or a CAN bus error has been detected. A change in the <i>TXOK</i>, <i>RXOK</i> or <i>LEC</i> bits in the CANSTS register generates an interrupt.</td> </tr> </tbody> </table>	Value	Description	0	No status interrupt is generated.	1	An interrupt is generated when a message has successfully been transmitted or received, or a CAN bus error has been detected. A change in the <i>TXOK</i> , <i>RXOK</i> or <i>LEC</i> bits in the CANSTS register generates an interrupt.
Value	Description									
0	No status interrupt is generated.									
1	An interrupt is generated when a message has successfully been transmitted or received, or a CAN bus error has been detected. A change in the <i>TXOK</i> , <i>RXOK</i> or <i>LEC</i> bits in the CANSTS register generates an interrupt.									
1	IE	R/W	0	CAN Interrupt Enable <table border="1"> <thead> <tr> <th>Value</th> <th>Description</th> </tr> </thead> <tbody> <tr> <td>0</td> <td>Interrupts disabled.</td> </tr> <tr> <td>1</td> <td>Interrupts enabled.</td> </tr> </tbody> </table>	Value	Description	0	Interrupts disabled.	1	Interrupts enabled.
Value	Description									
0	Interrupts disabled.									
1	Interrupts enabled.									
0	INIT	R/W	1	Initialization <table border="1"> <thead> <tr> <th>Value</th> <th>Description</th> </tr> </thead> <tbody> <tr> <td>0</td> <td>Normal operation.</td> </tr> <tr> <td>1</td> <td>Initialization started.</td> </tr> </tbody> </table>	Value	Description	0	Normal operation.	1	Initialization started.
Value	Description									
0	Normal operation.									
1	Initialization started.									

Register 2: CAN Status (CANSTS), offset 0x004

Important: This register is read-sensitive. See the register description for details.

The status register contains information for interrupt servicing such as Bus-Off, error count threshold, and error types.

The LEC field holds the code that indicates the type of the last error to occur on the CAN bus. This field is cleared when a message has been transferred (reception or transmission) without error. The unused error code 0x7 may be written by the CPU to manually set this field to an invalid error so that it can be checked for a change later.

An error interrupt is generated by the BOFF and EWARN bits, and a status interrupt is generated by the RXOK, TXOK, and LEC bits, if the corresponding enable bits in the **CAN Control (CANCTL)** register are set. A change of the EPASS bit or a write to the RXOK, TXOK, or LEC bits does not generate an interrupt.

Reading the **CAN Status (CANSTS)** register clears the **CAN Interrupt (CANINT)** register, if it is pending.

CAN Status (CANSTS)

CAN0 base: 0x4004.0000
 CAN1 base: 0x4004.1000
 Offset 0x004
 Type R/W, reset 0x0000.0000

	31	30	29	28	27	26	25	24	23	22	21	20	19	18	17	16
	reserved															
Type	RO	RO	RO	RO	RO	RO	RO	RO	RO	RO	RO	RO	RO	RO	RO	RO
Reset	0	0	0	0	0	0	0	0	0	0	0	0	0	0	0	0
	15	14	13	12	11	10	9	8	7	6	5	4	3	2	1	0
	reserved								BOFF	EWARN	EPASS	RXOK	TXOK	LEC		
Type	RO	RO	RO	RO	RO	RO	RO	RO	RO	RO	RO	R/W	R/W	R/W	R/W	R/W
Reset	0	0	0	0	0	0	0	0	0	0	0	0	0	0	0	0

Bit/Field	Name	Type	Reset	Description						
31:8	reserved	RO	0x0000.00	Software should not rely on the value of a reserved bit. To provide compatibility with future products, the value of a reserved bit should be preserved across a read-modify-write operation.						
7	BOFF	RO	0	Bus-Off Status						
				<table border="0"> <tr> <td style="padding-right: 20px;">Value</td> <td>Description</td> </tr> <tr> <td>0</td> <td>The CAN controller is not in bus-off state.</td> </tr> <tr> <td>1</td> <td>The CAN controller is in bus-off state.</td> </tr> </table>	Value	Description	0	The CAN controller is not in bus-off state.	1	The CAN controller is in bus-off state.
Value	Description									
0	The CAN controller is not in bus-off state.									
1	The CAN controller is in bus-off state.									
6	EWARN	RO	0	Warning Status						
				<table border="0"> <tr> <td style="padding-right: 20px;">Value</td> <td>Description</td> </tr> <tr> <td>0</td> <td>Both error counters are below the error warning limit of 96.</td> </tr> <tr> <td>1</td> <td>At least one of the error counters has reached the error warning limit of 96.</td> </tr> </table>	Value	Description	0	Both error counters are below the error warning limit of 96.	1	At least one of the error counters has reached the error warning limit of 96.
Value	Description									
0	Both error counters are below the error warning limit of 96.									
1	At least one of the error counters has reached the error warning limit of 96.									

Bit/Field	Name	Type	Reset	Description						
5	EPASS	RO	0	<p>Error Passive</p> <table border="1"> <thead> <tr> <th>Value</th> <th>Description</th> </tr> </thead> <tbody> <tr> <td>0</td> <td>The CAN module is in the Error Active state, that is, the receive or transmit error count is less than or equal to 127.</td> </tr> <tr> <td>1</td> <td>The CAN module is in the Error Passive state, that is, the receive or transmit error count is greater than 127.</td> </tr> </tbody> </table>	Value	Description	0	The CAN module is in the Error Active state, that is, the receive or transmit error count is less than or equal to 127.	1	The CAN module is in the Error Passive state, that is, the receive or transmit error count is greater than 127.
Value	Description									
0	The CAN module is in the Error Active state, that is, the receive or transmit error count is less than or equal to 127.									
1	The CAN module is in the Error Passive state, that is, the receive or transmit error count is greater than 127.									
4	RXOK	R/W	0	<p>Received a Message Successfully</p> <table border="1"> <thead> <tr> <th>Value</th> <th>Description</th> </tr> </thead> <tbody> <tr> <td>0</td> <td>Since this bit was last cleared, no message has been successfully received.</td> </tr> <tr> <td>1</td> <td>Since this bit was last cleared, a message has been successfully received, independent of the result of the acceptance filtering.</td> </tr> </tbody> </table> <p>This bit must be cleared by writing a 0 to it.</p>	Value	Description	0	Since this bit was last cleared, no message has been successfully received.	1	Since this bit was last cleared, a message has been successfully received, independent of the result of the acceptance filtering.
Value	Description									
0	Since this bit was last cleared, no message has been successfully received.									
1	Since this bit was last cleared, a message has been successfully received, independent of the result of the acceptance filtering.									
3	TXOK	R/W	0	<p>Transmitted a Message Successfully</p> <table border="1"> <thead> <tr> <th>Value</th> <th>Description</th> </tr> </thead> <tbody> <tr> <td>0</td> <td>Since this bit was last cleared, no message has been successfully transmitted.</td> </tr> <tr> <td>1</td> <td>Since this bit was last cleared, a message has been successfully transmitted error-free and acknowledged by at least one other node.</td> </tr> </tbody> </table> <p>This bit must be cleared by writing a 0 to it.</p>	Value	Description	0	Since this bit was last cleared, no message has been successfully transmitted.	1	Since this bit was last cleared, a message has been successfully transmitted error-free and acknowledged by at least one other node.
Value	Description									
0	Since this bit was last cleared, no message has been successfully transmitted.									
1	Since this bit was last cleared, a message has been successfully transmitted error-free and acknowledged by at least one other node.									

Bit/Field	Name	Type	Reset	Description																																				
2:0	LEC	R/W	0x0	<p>Last Error Code</p> <p>This is the type of the last error to occur on the CAN bus.</p> <table border="1"> <thead> <tr> <th>Value</th> <th>Description</th> </tr> </thead> <tbody> <tr> <td>0x0</td> <td>No Error</td> </tr> <tr> <td>0x1</td> <td>Stuff Error</td> </tr> <tr> <td></td> <td>More than 5 equal bits in a sequence have occurred in a part of a received message where this is not allowed.</td> </tr> <tr> <td>0x2</td> <td>Format Error</td> </tr> <tr> <td></td> <td>A fixed format part of the received frame has the wrong format.</td> </tr> <tr> <td>0x3</td> <td>ACK Error</td> </tr> <tr> <td></td> <td>The message transmitted was not acknowledged by another node.</td> </tr> <tr> <td>0x4</td> <td>Bit 1 Error</td> </tr> <tr> <td></td> <td>When a message is transmitted, the CAN controller monitors the data lines to detect any conflicts. When the arbitration field is transmitted, data conflicts are a part of the arbitration protocol. When other frame fields are transmitted, data conflicts are considered errors.</td> </tr> <tr> <td></td> <td>A Bit 1 Error indicates that the device wanted to send a High level (logical 1) but the monitored bus value was Low (logical 0).</td> </tr> <tr> <td>0x5</td> <td>Bit 0 Error</td> </tr> <tr> <td></td> <td>A Bit 0 Error indicates that the device wanted to send a Low level (logical 0), but the monitored bus value was High (logical 1).</td> </tr> <tr> <td></td> <td>During bus-off recovery, this status is set each time a sequence of 11 High bits has been monitored. By checking for this status, software can monitor the proceeding of the bus-off recovery sequence without any disturbances to the bus.</td> </tr> <tr> <td>0x6</td> <td>CRC Error</td> </tr> <tr> <td></td> <td>The CRC checksum was incorrect in the received message, indicating that the calculated value received did not match the calculated CRC of the data.</td> </tr> <tr> <td>0x7</td> <td>No Event</td> </tr> <tr> <td></td> <td>When the LEC bit shows this value, no CAN bus event was detected since this value was written to the LEC field.</td> </tr> </tbody> </table>	Value	Description	0x0	No Error	0x1	Stuff Error		More than 5 equal bits in a sequence have occurred in a part of a received message where this is not allowed.	0x2	Format Error		A fixed format part of the received frame has the wrong format.	0x3	ACK Error		The message transmitted was not acknowledged by another node.	0x4	Bit 1 Error		When a message is transmitted, the CAN controller monitors the data lines to detect any conflicts. When the arbitration field is transmitted, data conflicts are a part of the arbitration protocol. When other frame fields are transmitted, data conflicts are considered errors.		A Bit 1 Error indicates that the device wanted to send a High level (logical 1) but the monitored bus value was Low (logical 0).	0x5	Bit 0 Error		A Bit 0 Error indicates that the device wanted to send a Low level (logical 0), but the monitored bus value was High (logical 1).		During bus-off recovery, this status is set each time a sequence of 11 High bits has been monitored. By checking for this status, software can monitor the proceeding of the bus-off recovery sequence without any disturbances to the bus.	0x6	CRC Error		The CRC checksum was incorrect in the received message, indicating that the calculated value received did not match the calculated CRC of the data.	0x7	No Event		When the LEC bit shows this value, no CAN bus event was detected since this value was written to the LEC field.
Value	Description																																							
0x0	No Error																																							
0x1	Stuff Error																																							
	More than 5 equal bits in a sequence have occurred in a part of a received message where this is not allowed.																																							
0x2	Format Error																																							
	A fixed format part of the received frame has the wrong format.																																							
0x3	ACK Error																																							
	The message transmitted was not acknowledged by another node.																																							
0x4	Bit 1 Error																																							
	When a message is transmitted, the CAN controller monitors the data lines to detect any conflicts. When the arbitration field is transmitted, data conflicts are a part of the arbitration protocol. When other frame fields are transmitted, data conflicts are considered errors.																																							
	A Bit 1 Error indicates that the device wanted to send a High level (logical 1) but the monitored bus value was Low (logical 0).																																							
0x5	Bit 0 Error																																							
	A Bit 0 Error indicates that the device wanted to send a Low level (logical 0), but the monitored bus value was High (logical 1).																																							
	During bus-off recovery, this status is set each time a sequence of 11 High bits has been monitored. By checking for this status, software can monitor the proceeding of the bus-off recovery sequence without any disturbances to the bus.																																							
0x6	CRC Error																																							
	The CRC checksum was incorrect in the received message, indicating that the calculated value received did not match the calculated CRC of the data.																																							
0x7	No Event																																							
	When the LEC bit shows this value, no CAN bus event was detected since this value was written to the LEC field.																																							

Register 3: CAN Error Counter (CANERR), offset 0x008

This register contains the error counter values, which can be used to analyze the cause of an error.

CAN Error Counter (CANERR)

CAN0 base: 0x4004.0000

CAN1 base: 0x4004.1000

Offset 0x008

Type RO, reset 0x0000.0000

	31	30	29	28	27	26	25	24	23	22	21	20	19	18	17	16
	reserved															
Type	RO	RO	RO	RO	RO	RO	RO	RO	RO	RO	RO	RO	RO	RO	RO	RO
Reset	0	0	0	0	0	0	0	0	0	0	0	0	0	0	0	0
	15	14	13	12	11	10	9	8	7	6	5	4	3	2	1	0
	RP	REC						TEC								
Type	RO	RO	RO	RO	RO	RO	RO	RO	RO	RO	RO	RO	RO	RO	RO	RO
Reset	0	0	0	0	0	0	0	0	0	0	0	0	0	0	0	0

Bit/Field	Name	Type	Reset	Description
31:16	reserved	RO	0x0000	Software should not rely on the value of a reserved bit. To provide compatibility with future products, the value of a reserved bit should be preserved across a read-modify-write operation.
15	RP	RO	0	Received Error Passive
				Value Description
				0 The Receive Error counter is below the Error Passive level (127 or less).
				1 The Receive Error counter has reached the Error Passive level (128 or greater).
14:8	REC	RO	0x00	Receive Error Counter This field contains the state of the receiver error counter (0 to 127).
7:0	TEC	RO	0x00	Transmit Error Counter This field contains the state of the transmit error counter (0 to 255).

Register 4: CAN Bit Timing (CANBIT), offset 0x00C

This register is used to program the bit width and bit quantum. Values are programmed to the system clock frequency. This register is write-enabled by setting the `CCE` and `INIT` bits in the `CANCTL` register. See “Bit Time and Bit Rate” on page 1022 for more information.

CAN Bit Timing (CANBIT)

CAN0 base: 0x4004.0000
 CAN1 base: 0x4004.1000
 Offset 0x00C
 Type R/W, reset 0x0000.2301

	31	30	29	28	27	26	25	24	23	22	21	20	19	18	17	16
	reserved															
Type	RO	RO	RO	RO	RO	RO	RO	RO	RO	RO	RO	RO	RO	RO	RO	RO
Reset	0	0	0	0	0	0	0	0	0	0	0	0	0	0	0	0
	15	14	13	12	11	10	9	8	7	6	5	4	3	2	1	0
	reserved	TSEG2			TSEG1				SJW		BRP					
Type	RO	R/W	R/W	R/W	R/W	R/W	R/W	R/W	R/W	R/W	R/W	R/W	R/W	R/W	R/W	R/W
Reset	0	0	1	0	0	0	1	1	0	0	0	0	0	0	0	1

Bit/Field	Name	Type	Reset	Description
31:15	reserved	RO	0x0000	Software should not rely on the value of a reserved bit. To provide compatibility with future products, the value of a reserved bit should be preserved across a read-modify-write operation.
14:12	TSEG2	R/W	0x2	Time Segment after Sample Point 0x00-0x07: The actual interpretation by the hardware of this value is such that one more than the value programmed here is used. So, for example, the reset value of 0x2 means that 3 (2+1) bit time quanta are defined for <code>Phase2</code> (see Figure 16-4 on page 1023). The bit time quanta is defined by the <code>BRP</code> field.
11:8	TSEG1	R/W	0x3	Time Segment Before Sample Point 0x00-0x0F: The actual interpretation by the hardware of this value is such that one more than the value programmed here is used. So, for example, the reset value of 0x3 means that 4 (3+1) bit time quanta are defined for <code>Phase1</code> (see Figure 16-4 on page 1023). The bit time quanta is defined by the <code>BRP</code> field.
7:6	SJW	R/W	0x0	(Re)Synchronization Jump Width 0x00-0x03: The actual interpretation by the hardware of this value is such that one more than the value programmed here is used. During the start of frame (SOF), if the CAN controller detects a phase error (misalignment), it can adjust the length of <code>TSEG2</code> or <code>TSEG1</code> by the value in <code>SJW</code> . So the reset value of 0 adjusts the length by 1 bit time quanta.
5:0	BRP	R/W	0x1	Baud Rate Prescaler The value by which the oscillator frequency is divided for generating the bit time quanta. The bit time is built up from a multiple of this quantum. 0x00-0x03F: The actual interpretation by the hardware of this value is such that one more than the value programmed here is used. <code>BRP</code> defines the number of CAN clock periods that make up 1 bit time quanta, so the reset value is 2 bit time quanta (1+1). The <code>CANBRPE</code> register can be used to further divide the bit time.

Register 5: CAN Interrupt (CANINT), offset 0x010

This register indicates the source of the interrupt.

If several interrupts are pending, the **CAN Interrupt (CANINT)** register points to the pending interrupt with the highest priority, disregarding the order in which the interrupts occurred. An interrupt remains pending until the CPU has cleared it. If the **INTID** field is not 0x0000 (the default) and the **IE** bit in the **CANCTL** register is set, the interrupt is active. The interrupt line remains active until the **INTID** field is cleared by reading the **CANSTS** register, or until the **IE** bit in the **CANCTL** register is cleared.

Note: Reading the **CAN Status (CANSTS)** register clears the **CAN Interrupt (CANINT)** register, if it is pending.

CAN Interrupt (CANINT)

CAN0 base: 0x4004.0000

CAN1 base: 0x4004.1000

Offset 0x010

Type RO, reset 0x0000.0000

	31	30	29	28	27	26	25	24	23	22	21	20	19	18	17	16
	reserved															
Type	RO	RO	RO	RO	RO	RO	RO	RO	RO	RO	RO	RO	RO	RO	RO	RO
Reset	0	0	0	0	0	0	0	0	0	0	0	0	0	0	0	0
	15	14	13	12	11	10	9	8	7	6	5	4	3	2	1	0
	INTID															
Type	RO	RO	RO	RO	RO	RO	RO	RO	RO	RO	RO	RO	RO	RO	RO	RO
Reset	0	0	0	0	0	0	0	0	0	0	0	0	0	0	0	0

Bit/Field	Name	Type	Reset	Description
31:16	reserved	RO	0x0000	Software should not rely on the value of a reserved bit. To provide compatibility with future products, the value of a reserved bit should be preserved across a read-modify-write operation.
15:0	INTID	RO	0x0000	Interrupt Identifier The number in this field indicates the source of the interrupt.
			Value	Description
			0x0000	No interrupt pending
			0x0001-0x0020	Number of the message object that caused the interrupt
			0x0021-0x7FFF	Reserved
			0x8000	Status Interrupt
			0x8001-0xFFFF	Reserved

Register 6: CAN Test (CANTST), offset 0x014

This register is used for self-test and external pin access. It is write-enabled by setting the `TEST` bit in the `CANCTL` register. Different test functions may be combined, however, CAN transfers are affected if the `TX` bits in this register are not zero.

CAN Test (CANTST)

CAN0 base: 0x4004.0000
 CAN1 base: 0x4004.1000
 Offset 0x014
 Type R/W, reset 0x0000.0000

	31	30	29	28	27	26	25	24	23	22	21	20	19	18	17	16
	reserved															
Type	RO	RO	RO	RO	RO	RO	RO	RO	RO	RO	RO	RO	RO	RO	RO	RO
Reset	0	0	0	0	0	0	0	0	0	0	0	0	0	0	0	0
	15	14	13	12	11	10	9	8	7	6	5	4	3	2	1	0
	reserved								RX	TX		LBACK	SILENT	BASIC	reserved	
Type	RO	RO	RO	RO	RO	RO	RO	RO	RO	R/W	R/W	R/W	R/W	R/W	RO	RO
Reset	0	0	0	0	0	0	0	0	0	0	0	0	0	0	0	0

Bit/Field	Name	Type	Reset	Description																		
31:8	reserved	RO	0x0000.00	Software should not rely on the value of a reserved bit. To provide compatibility with future products, the value of a reserved bit should be preserved across a read-modify-write operation.																		
7	RX	RO	0	Receive Observation																		
				<table border="0"> <tr> <td>Value</td> <td>Description</td> </tr> <tr> <td>0</td> <td>The <code>CANnRx</code> pin is low.</td> </tr> <tr> <td>1</td> <td>The <code>CANnRx</code> pin is high.</td> </tr> </table>	Value	Description	0	The <code>CANnRx</code> pin is low.	1	The <code>CANnRx</code> pin is high.												
Value	Description																					
0	The <code>CANnRx</code> pin is low.																					
1	The <code>CANnRx</code> pin is high.																					
6:5	TX	R/W	0x0	Transmit Control																		
				Overrides control of the <code>CANnTx</code> pin.																		
				<table border="0"> <tr> <td>Value</td> <td>Description</td> </tr> <tr> <td>0x0</td> <td>CAN Module Control</td> </tr> <tr> <td></td> <td><code>CANnTx</code> is controlled by the CAN module; default operation</td> </tr> <tr> <td>0x1</td> <td>Sample Point</td> </tr> <tr> <td></td> <td>The sample point is driven on the <code>CANnTx</code> signal. This mode is useful to monitor bit timing.</td> </tr> <tr> <td>0x2</td> <td>Driven Low</td> </tr> <tr> <td></td> <td><code>CANnTx</code> drives a low value. This mode is useful for checking the physical layer of the CAN bus.</td> </tr> <tr> <td>0x3</td> <td>Driven High</td> </tr> <tr> <td></td> <td><code>CANnTx</code> drives a high value. This mode is useful for checking the physical layer of the CAN bus.</td> </tr> </table>	Value	Description	0x0	CAN Module Control		<code>CANnTx</code> is controlled by the CAN module; default operation	0x1	Sample Point		The sample point is driven on the <code>CANnTx</code> signal. This mode is useful to monitor bit timing.	0x2	Driven Low		<code>CANnTx</code> drives a low value. This mode is useful for checking the physical layer of the CAN bus.	0x3	Driven High		<code>CANnTx</code> drives a high value. This mode is useful for checking the physical layer of the CAN bus.
Value	Description																					
0x0	CAN Module Control																					
	<code>CANnTx</code> is controlled by the CAN module; default operation																					
0x1	Sample Point																					
	The sample point is driven on the <code>CANnTx</code> signal. This mode is useful to monitor bit timing.																					
0x2	Driven Low																					
	<code>CANnTx</code> drives a low value. This mode is useful for checking the physical layer of the CAN bus.																					
0x3	Driven High																					
	<code>CANnTx</code> drives a high value. This mode is useful for checking the physical layer of the CAN bus.																					

Bit/Field	Name	Type	Reset	Description	
4	LBACK	R/W	0	Loopback Mode	
				Value	Description
				0	Loopback mode is disabled.
				1	Loopback mode is enabled. In loopback mode, the data from the transmitter is routed into the receiver. Any data on the receive input is ignored.
3	SILENT	R/W	0	Silent Mode	
				Value	Description
				0	Silent mode is disabled.
				1	Silent mode is enabled. In silent mode, the CAN controller does not transmit data but instead monitors the bus. This mode is also known as Bus Monitor mode.
2	BASIC	R/W	0	Basic Mode	
				Value	Description
				0	Basic mode is disabled.
				1	Basic mode is enabled. In basic mode, software should use the CANIF1 registers as the transmit buffer and use the CANIF2 registers as the receive buffer.
1:0	reserved	RO	0x0	Software should not rely on the value of a reserved bit. To provide compatibility with future products, the value of a reserved bit should be preserved across a read-modify-write operation.	

Register 7: CAN Baud Rate Prescaler Extension (CANBRPE), offset 0x018

This register is used to further divide the bit time set with the `BRP` bit in the `CANBIT` register. It is write-enabled by setting the `CCE` bit in the `CANCTL` register.

CAN Baud Rate Prescaler Extension (CANBRPE)

CAN0 base: 0x4004.0000
 CAN1 base: 0x4004.1000
 Offset 0x018
 Type R/W, reset 0x0000.0000

	31	30	29	28	27	26	25	24	23	22	21	20	19	18	17	16
	reserved															
Type	RO	RO	RO	RO	RO	RO	RO	RO	RO	RO	RO	RO	RO	RO	RO	RO
Reset	0	0	0	0	0	0	0	0	0	0	0	0	0	0	0	0
	15	14	13	12	11	10	9	8	7	6	5	4	3	2	1	0
	reserved												BRPE			
Type	RO	RO	RO	RO	RO	RO	RO	RO	RO	RO	RO	RO	R/W	R/W	R/W	R/W
Reset	0	0	0	0	0	0	0	0	0	0	0	0	0	0	0	0

Bit/Field	Name	Type	Reset	Description
31:4	reserved	RO	0x0000.000	Software should not rely on the value of a reserved bit. To provide compatibility with future products, the value of a reserved bit should be preserved across a read-modify-write operation.
3:0	BRPE	R/W	0x0	Baud Rate Prescaler Extension 0x00-0x0F: Extend the <code>BRP</code> bit in the <code>CANBIT</code> register to values up to 1023. The actual interpretation by the hardware is one more than the value programmed by <code>BRPE</code> (MSBs) and <code>BRP</code> (LSBs).

Register 8: CAN IF1 Command Request (CANIF1CRQ), offset 0x020**Register 9: CAN IF2 Command Request (CANIF2CRQ), offset 0x080**

A message transfer is started as soon as there is a write of the message object number to the `MNUM` field when the `TXRQST` bit in the `CANIF1MCTL` register is set. With this write operation, the `BUSY` bit is automatically set to indicate that a transfer between the CAN Interface Registers and the internal message RAM is in progress. After a wait time of 3 to 6 `CAN_CLK` periods, the transfer between the interface register and the message RAM completes, which then clears the `BUSY` bit.

CAN IFn Command Request (CANIFnCRQ)

CAN0 base: 0x4004.0000
 CAN1 base: 0x4004.1000
 Offset 0x020
 Type R/W, reset 0x0000.0001

	31	30	29	28	27	26	25	24	23	22	21	20	19	18	17	16
	reserved															
Type	RO	RO	RO	RO	RO	RO	RO	RO	RO	RO	RO	RO	RO	RO	RO	RO
Reset	0	0	0	0	0	0	0	0	0	0	0	0	0	0	0	0
	15	14	13	12	11	10	9	8	7	6	5	4	3	2	1	0
	BUSY	reserved									MNUM					
Type	RO	RO	RO	RO	RO	RO	RO	RO	RO	RO	R/W	R/W	R/W	R/W	R/W	R/W
Reset	0	0	0	0	0	0	0	0	0	0	0	0	0	0	0	1

Bit/Field	Name	Type	Reset	Description														
31:16	reserved	RO	0x0000	Software should not rely on the value of a reserved bit. To provide compatibility with future products, the value of a reserved bit should be preserved across a read-modify-write operation.														
15	BUSY	RO	0	Busy Flag														
				<table border="1"> <thead> <tr> <th>Value</th> <th>Description</th> </tr> </thead> <tbody> <tr> <td>0</td> <td>This bit is cleared when read/write action has finished.</td> </tr> <tr> <td>1</td> <td>This bit is set when a write occurs to the message number in this register.</td> </tr> </tbody> </table>	Value	Description	0	This bit is cleared when read/write action has finished.	1	This bit is set when a write occurs to the message number in this register.								
Value	Description																	
0	This bit is cleared when read/write action has finished.																	
1	This bit is set when a write occurs to the message number in this register.																	
14:6	reserved	RO	0x00	Software should not rely on the value of a reserved bit. To provide compatibility with future products, the value of a reserved bit should be preserved across a read-modify-write operation.														
5:0	MNUM	R/W	0x01	<p>Message Number</p> <p>Selects one of the 32 message objects in the message RAM for data transfer. The message objects are numbered from 1 to 32.</p> <table border="1"> <thead> <tr> <th>Value</th> <th>Description</th> </tr> </thead> <tbody> <tr> <td>0x00</td> <td>Reserved</td> </tr> <tr> <td>0</td> <td>0 is not a valid message number; it is interpreted as 0x20, or object 32.</td> </tr> <tr> <td>0x01-0x20</td> <td>Message Number</td> </tr> <tr> <td></td> <td>Indicates specified message object 1 to 32.</td> </tr> <tr> <td>0x21-0x3F</td> <td>Reserved</td> </tr> <tr> <td></td> <td>Not a valid message number; values are shifted and it is interpreted as 0x01-0x1F.</td> </tr> </tbody> </table>	Value	Description	0x00	Reserved	0	0 is not a valid message number; it is interpreted as 0x20, or object 32.	0x01-0x20	Message Number		Indicates specified message object 1 to 32.	0x21-0x3F	Reserved		Not a valid message number; values are shifted and it is interpreted as 0x01-0x1F.
Value	Description																	
0x00	Reserved																	
0	0 is not a valid message number; it is interpreted as 0x20, or object 32.																	
0x01-0x20	Message Number																	
	Indicates specified message object 1 to 32.																	
0x21-0x3F	Reserved																	
	Not a valid message number; values are shifted and it is interpreted as 0x01-0x1F.																	

Register 10: CAN IF1 Command Mask (CANIF1CMSK), offset 0x024

Register 11: CAN IF2 Command Mask (CANIF2CMSK), offset 0x084

Reading the Command Mask registers provides status for various functions. Writing to the Command Mask registers specifies the transfer direction and selects which buffer registers are the source or target of the data transfer.

Note that when a read from the message object buffer occurs when the WRNRD bit is clear and the CLRINTPND and/or NEWDAT bits are set, the interrupt pending and/or new data flags in the message object buffer are cleared.

CAN IFn Command Mask (CANIFnCMSK)

CAN0 base: 0x4004.0000
 CAN1 base: 0x4004.1000
 Offset 0x024
 Type R/W, reset 0x0000.0000

	31	30	29	28	27	26	25	24	23	22	21	20	19	18	17	16
	reserved															
Type	RO	RO	RO	RO	RO	RO	RO	RO	RO	RO	RO	RO	RO	RO	RO	RO
Reset	0	0	0	0	0	0	0	0	0	0	0	0	0	0	0	0
	15	14	13	12	11	10	9	8	7	6	5	4	3	2	1	0
	reserved								WRNRD	MASK	ARB	CONTROL	CLRINTPND	NEWDAT / TXRQST	DATAA	DATAB
Type	RO	RO	RO	RO	RO	RO	RO	RO	R/W	R/W	R/W	R/W	R/W	R/W	R/W	R/W
Reset	0	0	0	0	0	0	0	0	0	0	0	0	0	0	0	0

Bit/Field	Name	Type	Reset	Description						
31:8	reserved	RO	0x0000.00	Software should not rely on the value of a reserved bit. To provide compatibility with future products, the value of a reserved bit should be preserved across a read-modify-write operation.						
7	WRNRD	R/W	0	Write, Not Read						
				<table border="0"> <tr> <td>Value</td> <td>Description</td> </tr> <tr> <td>0</td> <td>Transfer the data in the CAN message object specified by the the MNUM field in the CANIFnCRQ register into the CANIFn registers.</td> </tr> <tr> <td>1</td> <td>Transfer the data in the CANIFn registers to the CAN message object specified by the MNUM field in the CAN Command Request (CANIFnCRQ).</td> </tr> </table> <p>Note: Interrupt pending and new data conditions in the message buffer can be cleared by reading from the buffer (WRNRD = 0) when the CLRINTPND and/or NEWDAT bits are set.</p>	Value	Description	0	Transfer the data in the CAN message object specified by the the MNUM field in the CANIFnCRQ register into the CANIFn registers.	1	Transfer the data in the CANIFn registers to the CAN message object specified by the MNUM field in the CAN Command Request (CANIFnCRQ).
Value	Description									
0	Transfer the data in the CAN message object specified by the the MNUM field in the CANIFnCRQ register into the CANIFn registers.									
1	Transfer the data in the CANIFn registers to the CAN message object specified by the MNUM field in the CAN Command Request (CANIFnCRQ).									
6	MASK	R/W	0	Access Mask Bits						
				<table border="0"> <tr> <td>Value</td> <td>Description</td> </tr> <tr> <td>0</td> <td>Mask bits unchanged.</td> </tr> <tr> <td>1</td> <td>Transfer IDMASK + DIR + MXTD of the message object into the Interface registers.</td> </tr> </table>	Value	Description	0	Mask bits unchanged.	1	Transfer IDMASK + DIR + MXTD of the message object into the Interface registers.
Value	Description									
0	Mask bits unchanged.									
1	Transfer IDMASK + DIR + MXTD of the message object into the Interface registers.									

Bit/Field	Name	Type	Reset	Description						
5	ARB	R/W	0	<p>Access Arbitration Bits</p> <table border="1"> <thead> <tr> <th>Value</th> <th>Description</th> </tr> </thead> <tbody> <tr> <td>0</td> <td>Arbitration bits unchanged.</td> </tr> <tr> <td>1</td> <td>Transfer ID + DIR + XTD + MSGVAL of the message object into the Interface registers.</td> </tr> </tbody> </table>	Value	Description	0	Arbitration bits unchanged.	1	Transfer ID + DIR + XTD + MSGVAL of the message object into the Interface registers.
Value	Description									
0	Arbitration bits unchanged.									
1	Transfer ID + DIR + XTD + MSGVAL of the message object into the Interface registers.									
4	CONTROL	R/W	0	<p>Access Control Bits</p> <table border="1"> <thead> <tr> <th>Value</th> <th>Description</th> </tr> </thead> <tbody> <tr> <td>0</td> <td>Control bits unchanged.</td> </tr> <tr> <td>1</td> <td>Transfer control bits from the CANIFnMCTL register into the Interface registers.</td> </tr> </tbody> </table>	Value	Description	0	Control bits unchanged.	1	Transfer control bits from the CANIFnMCTL register into the Interface registers.
Value	Description									
0	Control bits unchanged.									
1	Transfer control bits from the CANIFnMCTL register into the Interface registers.									
3	CLRINTPND	R/W	0	<p>Clear Interrupt Pending Bit</p> <p>The function of this bit depends on the configuration of the WRNRD bit.</p> <table border="1"> <thead> <tr> <th>Value</th> <th>Description</th> </tr> </thead> <tbody> <tr> <td>0</td> <td> <p>If WRNRD is clear, the interrupt pending status is transferred from the message buffer into the CANIFnMCTL register.</p> <p>If WRNRD is set, the INTPND bit in the message object remains unchanged.</p> </td> </tr> <tr> <td>1</td> <td> <p>If WRNRD is clear, the interrupt pending status is cleared in the message buffer. Note the value of this bit that is transferred to the CANIFnMCTL register always reflects the status of the bits before clearing.</p> <p>If WRNRD is set, the INTPND bit is cleared in the message object.</p> </td> </tr> </tbody> </table>	Value	Description	0	<p>If WRNRD is clear, the interrupt pending status is transferred from the message buffer into the CANIFnMCTL register.</p> <p>If WRNRD is set, the INTPND bit in the message object remains unchanged.</p>	1	<p>If WRNRD is clear, the interrupt pending status is cleared in the message buffer. Note the value of this bit that is transferred to the CANIFnMCTL register always reflects the status of the bits before clearing.</p> <p>If WRNRD is set, the INTPND bit is cleared in the message object.</p>
Value	Description									
0	<p>If WRNRD is clear, the interrupt pending status is transferred from the message buffer into the CANIFnMCTL register.</p> <p>If WRNRD is set, the INTPND bit in the message object remains unchanged.</p>									
1	<p>If WRNRD is clear, the interrupt pending status is cleared in the message buffer. Note the value of this bit that is transferred to the CANIFnMCTL register always reflects the status of the bits before clearing.</p> <p>If WRNRD is set, the INTPND bit is cleared in the message object.</p>									
2	NEWDAT / TXRQST	R/W	0	<p>NEWDAT / TXRQST Bit</p> <p>The function of this bit depends on the configuration of the WRNRD bit.</p> <table border="1"> <thead> <tr> <th>Value</th> <th>Description</th> </tr> </thead> <tbody> <tr> <td>0</td> <td> <p>If WRNRD is clear, the value of the new data status is transferred from the message buffer into the CANIFnMCTL register.</p> <p>If WRNRD is set, a transmission is not requested.</p> </td> </tr> <tr> <td>1</td> <td> <p>If WRNRD is clear, the new data status is cleared in the message buffer. Note the value of this bit that is transferred to the CANIFnMCTL register always reflects the status of the bits before clearing.</p> <p>If WRNRD is set, a transmission is requested. Note that when this bit is set, the TXRQST bit in the CANIFnMCTL register is ignored.</p> </td> </tr> </tbody> </table>	Value	Description	0	<p>If WRNRD is clear, the value of the new data status is transferred from the message buffer into the CANIFnMCTL register.</p> <p>If WRNRD is set, a transmission is not requested.</p>	1	<p>If WRNRD is clear, the new data status is cleared in the message buffer. Note the value of this bit that is transferred to the CANIFnMCTL register always reflects the status of the bits before clearing.</p> <p>If WRNRD is set, a transmission is requested. Note that when this bit is set, the TXRQST bit in the CANIFnMCTL register is ignored.</p>
Value	Description									
0	<p>If WRNRD is clear, the value of the new data status is transferred from the message buffer into the CANIFnMCTL register.</p> <p>If WRNRD is set, a transmission is not requested.</p>									
1	<p>If WRNRD is clear, the new data status is cleared in the message buffer. Note the value of this bit that is transferred to the CANIFnMCTL register always reflects the status of the bits before clearing.</p> <p>If WRNRD is set, a transmission is requested. Note that when this bit is set, the TXRQST bit in the CANIFnMCTL register is ignored.</p>									

Bit/Field	Name	Type	Reset	Description						
1	DATAA	R/W	0	<p>Access Data Byte 0 to 3</p> <p>The function of this bit depends on the configuration of the WRNRD bit.</p> <table border="1"> <thead> <tr> <th>Value</th> <th>Description</th> </tr> </thead> <tbody> <tr> <td>0</td> <td>Data bytes 0-3 are unchanged.</td> </tr> <tr> <td>1</td> <td> <p>If WRNRD is clear, transfer data bytes 0-3 in CANIFnDA1 and CANIFnDA2 to the message object.</p> <p>If WRNRD is set, transfer data bytes 0-3 in message object to CANIFnDA1 and CANIFnDA2.</p> </td> </tr> </tbody> </table>	Value	Description	0	Data bytes 0-3 are unchanged.	1	<p>If WRNRD is clear, transfer data bytes 0-3 in CANIFnDA1 and CANIFnDA2 to the message object.</p> <p>If WRNRD is set, transfer data bytes 0-3 in message object to CANIFnDA1 and CANIFnDA2.</p>
Value	Description									
0	Data bytes 0-3 are unchanged.									
1	<p>If WRNRD is clear, transfer data bytes 0-3 in CANIFnDA1 and CANIFnDA2 to the message object.</p> <p>If WRNRD is set, transfer data bytes 0-3 in message object to CANIFnDA1 and CANIFnDA2.</p>									
0	DATAB	R/W	0	<p>Access Data Byte 4 to 7</p> <p>The function of this bit depends on the configuration of the WRNRD bit as follows:</p> <table border="1"> <thead> <tr> <th>Value</th> <th>Description</th> </tr> </thead> <tbody> <tr> <td>0</td> <td>Data bytes 4-7 are unchanged.</td> </tr> <tr> <td>1</td> <td> <p>If WRNRD is clear, transfer data bytes 4-7 in CANIFnDA1 and CANIFnDA2 to the message object.</p> <p>If WRNRD is set, transfer data bytes 4-7 in message object to CANIFnDA1 and CANIFnDA2.</p> </td> </tr> </tbody> </table>	Value	Description	0	Data bytes 4-7 are unchanged.	1	<p>If WRNRD is clear, transfer data bytes 4-7 in CANIFnDA1 and CANIFnDA2 to the message object.</p> <p>If WRNRD is set, transfer data bytes 4-7 in message object to CANIFnDA1 and CANIFnDA2.</p>
Value	Description									
0	Data bytes 4-7 are unchanged.									
1	<p>If WRNRD is clear, transfer data bytes 4-7 in CANIFnDA1 and CANIFnDA2 to the message object.</p> <p>If WRNRD is set, transfer data bytes 4-7 in message object to CANIFnDA1 and CANIFnDA2.</p>									

Register 12: CAN IF1 Mask 1 (CANIF1MSK1), offset 0x028**Register 13: CAN IF2 Mask 1 (CANIF2MSK1), offset 0x088**

The mask information provided in this register accompanies the data (**CANIFnDAn**), arbitration information (**CANIFnARBn**), and control information (**CANIFnMCTL**) to the message object in the message RAM. The mask is used with the **ID** bit in the **CANIFnARBn** register for acceptance filtering. Additional mask information is contained in the **CANIFnMSK2** register.

CAN IFn Mask 1 (CANIFnMSK1)

CAN0 base: 0x4004.0000

CAN1 base: 0x4004.1000

Offset 0x028

Type R/W, reset 0x0000.FFFF

	31	30	29	28	27	26	25	24	23	22	21	20	19	18	17	16
	reserved															
Type	RO	RO	RO	RO	RO	RO	RO	RO	RO	RO	RO	RO	RO	RO	RO	RO
Reset	0	0	0	0	0	0	0	0	0	0	0	0	0	0	0	0
	15	14	13	12	11	10	9	8	7	6	5	4	3	2	1	0
	MSK															
Type	R/W	R/W	R/W	R/W	R/W	R/W	R/W	R/W	R/W	R/W	R/W	R/W	R/W	R/W	R/W	R/W
Reset	1	1	1	1	1	1	1	1	1	1	1	1	1	1	1	1

Bit/Field	Name	Type	Reset	Description
31:16	reserved	RO	0x0000	Software should not rely on the value of a reserved bit. To provide compatibility with future products, the value of a reserved bit should be preserved across a read-modify-write operation.
15:0	MSK	R/W	0xFFFF	Identifier Mask When using a 29-bit identifier, these bits are used for bits [15:0] of the ID. The MSK field in the CANIFnMSK2 register are used for bits [28:16] of the ID. When using an 11-bit identifier, these bits are ignored.
	Value	Description		
	0	The corresponding identifier field (ID) in the message object cannot inhibit the match in acceptance filtering.		
	1	The corresponding identifier field (ID) is used for acceptance filtering.		

Register 14: CAN IF1 Mask 2 (CANIF1MSK2), offset 0x02C

Register 15: CAN IF2 Mask 2 (CANIF2MSK2), offset 0x08C

This register holds extended mask information that accompanies the **CANIFnMSK1** register.

CAN IFn Mask 2 (CANIFnMSK2)

CAN0 base: 0x4004.0000
 CAN1 base: 0x4004.1000
 Offset 0x02C
 Type R/W, reset 0x0000.FFFF

	31	30	29	28	27	26	25	24	23	22	21	20	19	18	17	16
	reserved															
Type	RO	RO	RO	RO	RO	RO	RO	RO	RO	RO	RO	RO	RO	RO	RO	RO
Reset	0	0	0	0	0	0	0	0	0	0	0	0	0	0	0	0
	15	14	13	12	11	10	9	8	7	6	5	4	3	2	1	0
	MXTD	MDIR	reserved													
Type	R/W	R/W	RO	R/W	R/W	R/W	R/W	R/W	R/W	R/W	R/W	R/W	R/W	R/W	R/W	R/W
Reset	1	1	1	0	0	0	0	0	1	1	1	1	1	1	1	1

Bit/Field	Name	Type	Reset	Description						
31:16	reserved	RO	0x0000	Software should not rely on the value of a reserved bit. To provide compatibility with future products, the value of a reserved bit should be preserved across a read-modify-write operation.						
15	MXTD	R/W	1	Mask Extended Identifier <table border="0"> <tr> <td>Value</td> <td>Description</td> </tr> <tr> <td>0</td> <td>The extended identifier bit (<i>XTD</i> in the CANIFnARB2 register) has no effect on the acceptance filtering.</td> </tr> <tr> <td>1</td> <td>The extended identifier bit <i>XTD</i> is used for acceptance filtering.</td> </tr> </table>	Value	Description	0	The extended identifier bit (<i>XTD</i> in the CANIFnARB2 register) has no effect on the acceptance filtering.	1	The extended identifier bit <i>XTD</i> is used for acceptance filtering.
Value	Description									
0	The extended identifier bit (<i>XTD</i> in the CANIFnARB2 register) has no effect on the acceptance filtering.									
1	The extended identifier bit <i>XTD</i> is used for acceptance filtering.									
14	MDIR	R/W	1	Mask Message Direction <table border="0"> <tr> <td>Value</td> <td>Description</td> </tr> <tr> <td>0</td> <td>The message direction bit (<i>DIR</i> in the CANIFnARB2 register) has no effect for acceptance filtering.</td> </tr> <tr> <td>1</td> <td>The message direction bit <i>DIR</i> is used for acceptance filtering.</td> </tr> </table>	Value	Description	0	The message direction bit (<i>DIR</i> in the CANIFnARB2 register) has no effect for acceptance filtering.	1	The message direction bit <i>DIR</i> is used for acceptance filtering.
Value	Description									
0	The message direction bit (<i>DIR</i> in the CANIFnARB2 register) has no effect for acceptance filtering.									
1	The message direction bit <i>DIR</i> is used for acceptance filtering.									
13	reserved	RO	1	Software should not rely on the value of a reserved bit. To provide compatibility with future products, the value of a reserved bit should be preserved across a read-modify-write operation.						

Bit/Field	Name	Type	Reset	Description						
12:0	MSK	R/W	0xFF	<p>Identifier Mask</p> <p>When using a 29-bit identifier, these bits are used for bits [28:16] of the ID. The <code>MSK</code> field in the <code>CANIFnMSK1</code> register are used for bits [15:0] of the ID. When using an 11-bit identifier, <code>MSK[12:2]</code> are used for bits [10:0] of the ID.</p> <table><thead><tr><th>Value</th><th>Description</th></tr></thead><tbody><tr><td>0</td><td>The corresponding identifier field (<code>ID</code>) in the message object cannot inhibit the match in acceptance filtering.</td></tr><tr><td>1</td><td>The corresponding identifier field (<code>ID</code>) is used for acceptance filtering.</td></tr></tbody></table>	Value	Description	0	The corresponding identifier field (<code>ID</code>) in the message object cannot inhibit the match in acceptance filtering.	1	The corresponding identifier field (<code>ID</code>) is used for acceptance filtering.
Value	Description									
0	The corresponding identifier field (<code>ID</code>) in the message object cannot inhibit the match in acceptance filtering.									
1	The corresponding identifier field (<code>ID</code>) is used for acceptance filtering.									

Register 16: CAN IF1 Arbitration 1 (CANIF1ARB1), offset 0x030

Register 17: CAN IF2 Arbitration 1 (CANIF2ARB1), offset 0x090

These registers hold the identifiers for acceptance filtering.

CAN IFn Arbitration 1 (CANIFnARB1)

CAN0 base: 0x4004.0000
 CAN1 base: 0x4004.1000
 Offset 0x030
 Type R/W, reset 0x0000.0000

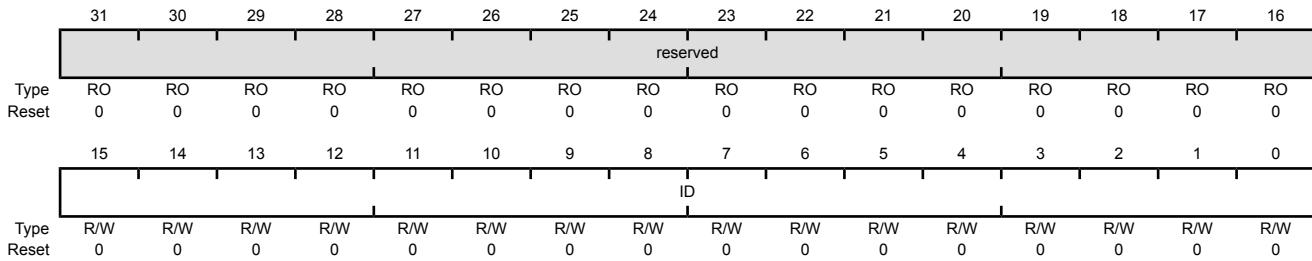

Bit/Field	Name	Type	Reset	Description
31:16	reserved	RO	0x0000	Software should not rely on the value of a reserved bit. To provide compatibility with future products, the value of a reserved bit should be preserved across a read-modify-write operation.
15:0	ID	R/W	0x0000	<p>Message Identifier</p> <p>This bit field is used with the ID field in the CANIFnARB2 register to create the message identifier.</p> <p>When using a 29-bit identifier, bits 15:0 of the CANIFnARB1 register are [15:0] of the ID, while bits 12:0 of the CANIFnARB2 register are [28:16] of the ID.</p> <p>When using an 11-bit identifier, these bits are not used.</p>

Register 18: CAN IF1 Arbitration 2 (CANIF1ARB2), offset 0x034**Register 19: CAN IF2 Arbitration 2 (CANIF2ARB2), offset 0x094**

These registers hold information for acceptance filtering.

CAN IFn Arbitration 2 (CANIFnARB2)

CAN0 base: 0x4004.0000

CAN1 base: 0x4004.1000

Offset 0x034

Type R/W, reset 0x0000.0000

	31	30	29	28	27	26	25	24	23	22	21	20	19	18	17	16
	reserved															
Type	RO	RO	RO	RO	RO	RO	RO	RO	RO	RO	RO	RO	RO	RO	RO	RO
Reset	0	0	0	0	0	0	0	0	0	0	0	0	0	0	0	0
	15	14	13	12	11	10	9	8	7	6	5	4	3	2	1	0
	MSGVAL	XTD	DIR							ID						
Type	R/W	R/W	R/W	R/W	R/W	R/W	R/W	R/W	R/W	R/W	R/W	R/W	R/W	R/W	R/W	R/W
Reset	0	0	0	0	0	0	0	0	0	0	0	0	0	0	0	0

Bit/Field	Name	Type	Reset	Description
31:16	reserved	RO	0x0000	Software should not rely on the value of a reserved bit. To provide compatibility with future products, the value of a reserved bit should be preserved across a read-modify-write operation.

15	MSGVAL	R/W	0	Message Valid
----	--------	-----	---	---------------

Value	Description
0	The message object is ignored by the message handler.
1	The message object is configured and ready to be considered by the message handler within the CAN controller.

All unused message objects should have this bit cleared during initialization and before clearing the `INIT` bit in the `CANCTL` register. The `MSGVAL` bit must also be cleared before any of the following bits are modified or if the message object is no longer required: the `ID` fields in the `CANIFnARBn` registers, the `XTD` and `DIR` bits in the `CANIFnARB2` register, or the `DLC` field in the `CANIFnMCTL` register.

14	XTD	R/W	0	Extended Identifier
----	-----	-----	---	---------------------

Value	Description
0	An 11-bit Standard Identifier is used for this message object.
1	A 29-bit Extended Identifier is used for this message object.

Bit/Field	Name	Type	Reset	Description						
13	DIR	R/W	0	<p>Message Direction</p> <table border="1"> <thead> <tr> <th>Value</th> <th>Description</th> </tr> </thead> <tbody> <tr> <td>0</td> <td>Receive. When the <code>TXRQST</code> bit in the CANIFnMCTL register is set, a remote frame with the identifier of this message object is received. On reception of a data frame with matching identifier, that message is stored in this message object.</td> </tr> <tr> <td>1</td> <td>Transmit. When the <code>TXRQST</code> bit in the CANIFnMCTL register is set, the respective message object is transmitted as a data frame. On reception of a remote frame with matching identifier, the <code>TXRQST</code> bit of this message object is set (if <code>RMTEN=1</code>).</td> </tr> </tbody> </table>	Value	Description	0	Receive. When the <code>TXRQST</code> bit in the CANIFnMCTL register is set, a remote frame with the identifier of this message object is received. On reception of a data frame with matching identifier, that message is stored in this message object.	1	Transmit. When the <code>TXRQST</code> bit in the CANIFnMCTL register is set, the respective message object is transmitted as a data frame. On reception of a remote frame with matching identifier, the <code>TXRQST</code> bit of this message object is set (if <code>RMTEN=1</code>).
Value	Description									
0	Receive. When the <code>TXRQST</code> bit in the CANIFnMCTL register is set, a remote frame with the identifier of this message object is received. On reception of a data frame with matching identifier, that message is stored in this message object.									
1	Transmit. When the <code>TXRQST</code> bit in the CANIFnMCTL register is set, the respective message object is transmitted as a data frame. On reception of a remote frame with matching identifier, the <code>TXRQST</code> bit of this message object is set (if <code>RMTEN=1</code>).									
12:0	ID	R/W	0x000	<p>Message Identifier</p> <p>This bit field is used with the <code>ID</code> field in the CANIFnARB2 register to create the message identifier.</p> <p>When using a 29-bit identifier, <code>ID[15:0]</code> of the CANIFnARB1 register are [15:0] of the ID, while these bits, <code>ID[12:0]</code>, are [28:16] of the ID.</p> <p>When using an 11-bit identifier, <code>ID[12:2]</code> are used for bits [10:0] of the ID. The <code>ID</code> field in the CANIFnARB1 register is ignored.</p>						

Register 20: CAN IF1 Message Control (CANIF1MCTL), offset 0x038**Register 21: CAN IF2 Message Control (CANIF2MCTL), offset 0x098**

This register holds the control information associated with the message object to be sent to the Message RAM.

CAN IFn Message Control (CANIFnMCTL)

CAN0 base: 0x4004.0000

CAN1 base: 0x4004.1000

Offset 0x038

Type R/W, reset 0x0000.0000

	31	30	29	28	27	26	25	24	23	22	21	20	19	18	17	16
	reserved															
Type	RO	RO	RO	RO	RO	RO	RO	RO	RO	RO	RO	RO	RO	RO	RO	RO
Reset	0	0	0	0	0	0	0	0	0	0	0	0	0	0	0	0
	15	14	13	12	11	10	9	8	7	6	5	4	3	2	1	0
	NEWDAT	MSGLST	INTPND	UMASK	TXIE	RXIE	RMTEN	TXRQST	EOB	reserved			DLC			
Type	R/W	R/W	R/W	R/W	R/W	R/W	R/W	R/W	R/W	RO	RO	RO	R/W	R/W	R/W	R/W
Reset	0	0	0	0	0	0	0	0	0	0	0	0	0	0	0	0

Bit/Field	Name	Type	Reset	Description
31:16	reserved	RO	0x0000	Software should not rely on the value of a reserved bit. To provide compatibility with future products, the value of a reserved bit should be preserved across a read-modify-write operation.
15	NEWDAT	R/W	0	New Data
				Value Description
				0 No new data has been written into the data portion of this message object by the message handler since the last time this flag was cleared by the CPU.
				1 The message handler or the CPU has written new data into the data portion of this message object.
14	MSGLST	R/W	0	Message Lost
				Value Description
				0 No message was lost since the last time this bit was cleared by the CPU.
				1 The message handler stored a new message into this object when NEWDAT was set; the CPU has lost a message.
				This bit is only valid for message objects when the DIR bit in the CANIFnARB2 register is clear (receive).
13	INTPND	R/W	0	Interrupt Pending
				Value Description
				0 This message object is not the source of an interrupt.
				1 This message object is the source of an interrupt. The interrupt identifier in the CANINT register points to this message object if there is not another interrupt source with a higher priority.

Bit/Field	Name	Type	Reset	Description	
12	UMASK	R/W	0	Use Acceptance Mask	
				Value	Description
				0	Mask is ignored.
				1	Use mask (MSK, MXTD, and MDIR bits in the CANIFnMSKn registers) for acceptance filtering.
11	TXIE	R/W	0	Transmit Interrupt Enable	
				Value	Description
				0	The INTPND bit in the CANIFnMCTL register is unchanged after a successful transmission of a frame.
				1	The INTPND bit in the CANIFnMCTL register is set after a successful transmission of a frame.
10	RXIE	R/W	0	Receive Interrupt Enable	
				Value	Description
				0	The INTPND bit in the CANIFnMCTL register is unchanged after a successful reception of a frame.
				1	The INTPND bit in the CANIFnMCTL register is set after a successful reception of a frame.
9	RMTEN	R/W	0	Remote Enable	
				Value	Description
				0	At the reception of a remote frame, the TXRQST bit in the CANIFnMCTL register is left unchanged.
				1	At the reception of a remote frame, the TXRQST bit in the CANIFnMCTL register is set.
8	TXRQST	R/W	0	Transmit Request	
				Value	Description
				0	This message object is not waiting for transmission.
				1	The transmission of this message object is requested and is not yet done.
				Note: If the WRNRD and TXRQST bits in the CANIFnCMSK register are set, this bit is ignored.	

Bit/Field	Name	Type	Reset	Description						
7	EOB	R/W	0	End of Buffer <table border="1"> <thead> <tr> <th>Value</th> <th>Description</th> </tr> </thead> <tbody> <tr> <td>0</td> <td>Message object belongs to a FIFO Buffer and is not the last message object of that FIFO Buffer.</td> </tr> <tr> <td>1</td> <td>Single message object or last message object of a FIFO Buffer.</td> </tr> </tbody> </table> <p>This bit is used to concatenate two or more message objects (up to 32) to build a FIFO buffer. For a single message object (thus not belonging to a FIFO buffer), this bit must be set.</p>	Value	Description	0	Message object belongs to a FIFO Buffer and is not the last message object of that FIFO Buffer.	1	Single message object or last message object of a FIFO Buffer.
Value	Description									
0	Message object belongs to a FIFO Buffer and is not the last message object of that FIFO Buffer.									
1	Single message object or last message object of a FIFO Buffer.									
6:4	reserved	RO	0x0	Software should not rely on the value of a reserved bit. To provide compatibility with future products, the value of a reserved bit should be preserved across a read-modify-write operation.						
3:0	DLC	R/W	0x0	Data Length Code <table border="1"> <thead> <tr> <th>Value</th> <th>Description</th> </tr> </thead> <tbody> <tr> <td>0x0-0x8</td> <td>Specifies the number of bytes in the data frame.</td> </tr> <tr> <td>0x9-0xF</td> <td>Defaults to a data frame with 8 bytes.</td> </tr> </tbody> </table> <p>The DLC field in the CANIFnMCTL register of a message object must be defined the same as in all the corresponding objects with the same identifier at other nodes. When the message handler stores a data frame, it writes DLC to the value given by the received message.</p>	Value	Description	0x0-0x8	Specifies the number of bytes in the data frame.	0x9-0xF	Defaults to a data frame with 8 bytes.
Value	Description									
0x0-0x8	Specifies the number of bytes in the data frame.									
0x9-0xF	Defaults to a data frame with 8 bytes.									

Register 22: CAN IF1 Data A1 (CANIF1DA1), offset 0x03C

Register 23: CAN IF1 Data A2 (CANIF1DA2), offset 0x040

Register 24: CAN IF1 Data B1 (CANIF1DB1), offset 0x044

Register 25: CAN IF1 Data B2 (CANIF1DB2), offset 0x048

Register 26: CAN IF2 Data A1 (CANIF2DA1), offset 0x09C

Register 27: CAN IF2 Data A2 (CANIF2DA2), offset 0x0A0

Register 28: CAN IF2 Data B1 (CANIF2DB1), offset 0x0A4

Register 29: CAN IF2 Data B2 (CANIF2DB2), offset 0x0A8

These registers contain the data to be sent or that has been received. In a CAN data frame, data byte 0 is the first byte to be transmitted or received and data byte 7 is the last byte to be transmitted or received. In CAN's serial bit stream, the MSB of each byte is transmitted first.

CAN IFn Data nn (CANIFnDnn)

CAN0 base: 0x4004.0000
 CAN1 base: 0x4004.1000
 Offset 0x03C
 Type R/W, reset 0x0000.0000

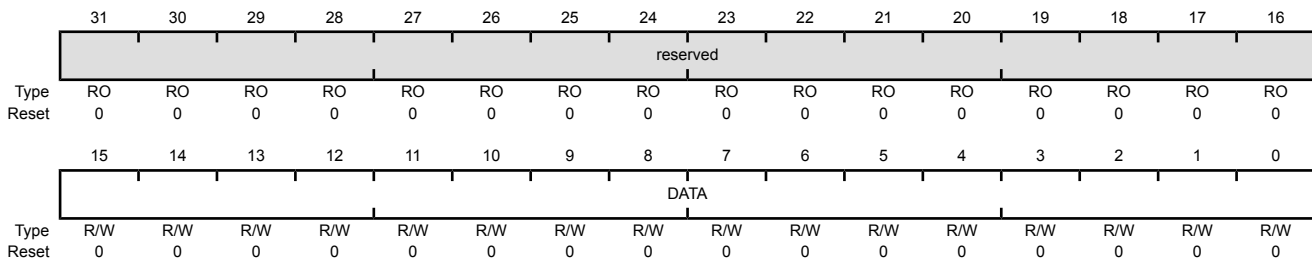

Bit/Field	Name	Type	Reset	Description
31:16	reserved	RO	0x0000	Software should not rely on the value of a reserved bit. To provide compatibility with future products, the value of a reserved bit should be preserved across a read-modify-write operation.
15:0	DATA	R/W	0x0000	Data The CANIFnDA1 registers contain data bytes 1 and 0; CANIFnDA2 data bytes 3 and 2; CANIFnDB1 data bytes 5 and 4; and CANIFnDB2 data bytes 7 and 6.

Register 30: CAN Transmission Request 1 (CANTXRQ1), offset 0x100**Register 31: CAN Transmission Request 2 (CANTXRQ2), offset 0x104**

The **CANTXRQ1** and **CANTXRQ2** registers hold the **TXRQST** bits of the 32 message objects. By reading out these bits, the CPU can check which message object has a transmission request pending. The **TXRQST** bit of a specific message object can be changed by three sources: (1) the CPU via the **CANIFnMCTL** register, (2) the message handler state machine after the reception of a remote frame, or (3) the message handler state machine after a successful transmission.

The **CANTXRQ1** register contains the **TXRQST** bits of the first 16 message objects in the message RAM; the **CANTXRQ2** register contains the **TXRQST** bits of the second 16 message objects.

CAN Transmission Request n (CANTXRQn)

CAN0 base: 0x4004.0000
 CAN1 base: 0x4004.1000
 Offset 0x100
 Type RO, reset 0x0000.0000

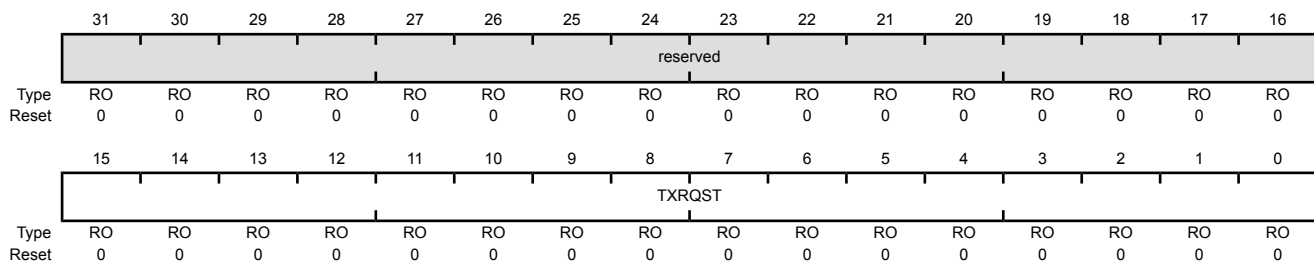

Bit/Field	Name	Type	Reset	Description
31:16	reserved	RO	0x0000	Software should not rely on the value of a reserved bit. To provide compatibility with future products, the value of a reserved bit should be preserved across a read-modify-write operation.
15:0	TXRQST	RO	0x0000	Transmission Request Bits
	Value	Description		
	0	The corresponding message object is not waiting for transmission.		
	1	The transmission of the corresponding message object is requested and is not yet done.		

Register 32: CAN New Data 1 (CANNWDA1), offset 0x120

Register 33: CAN New Data 2 (CANNWDA2), offset 0x124

The **CANNWDA1** and **CANNWDA2** registers hold the **NEWDAT** bits of the 32 message objects. By reading these bits, the CPU can check which message object has its data portion updated. The **NEWDAT** bit of a specific message object can be changed by three sources: (1) the CPU via the **CANIFnMCTL** register, (2) the message handler state machine after the reception of a data frame, or (3) the message handler state machine after a successful transmission.

The **CANNWDA1** register contains the **NEWDAT** bits of the first 16 message objects in the message RAM; the **CANNWDA2** register contains the **NEWDAT** bits of the second 16 message objects.

CAN New Data n (CANNWDAn)

CAN0 base: 0x4004.0000
 CAN1 base: 0x4004.1000
 Offset 0x120
 Type RO, reset 0x0000.0000

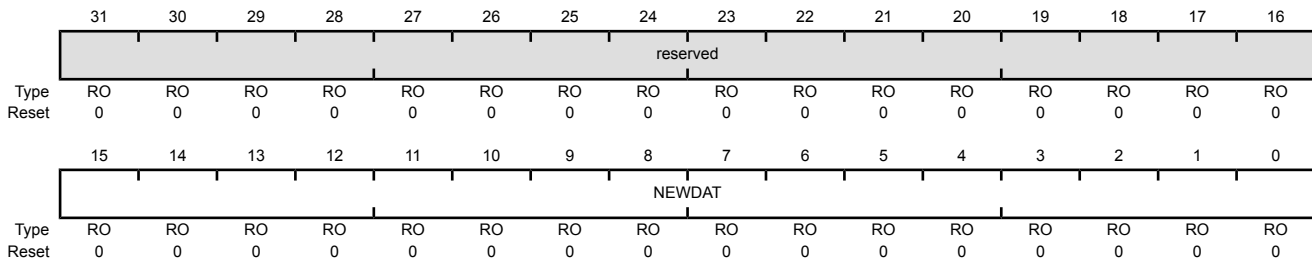

Bit/Field	Name	Type	Reset	Description
31:16	reserved	RO	0x0000	Software should not rely on the value of a reserved bit. To provide compatibility with future products, the value of a reserved bit should be preserved across a read-modify-write operation.
15:0	NEWDAT	RO	0x0000	New Data Bits
				Value Description
				0 No new data has been written into the data portion of the corresponding message object by the message handler since the last time this flag was cleared by the CPU.
				1 The message handler or the CPU has written new data into the data portion of the corresponding message object.

Register 34: CAN Message 1 Interrupt Pending (CANMSG1INT), offset 0x140**Register 35: CAN Message 2 Interrupt Pending (CANMSG2INT), offset 0x144**

The **CANMSG1INT** and **CANMSG2INT** registers hold the **INTPND** bits of the 32 message objects. By reading these bits, the CPU can check which message object has an interrupt pending. The **INTPND** bit of a specific message object can be changed through two sources: (1) the CPU via the **CANIFnMCTL** register, or (2) the message handler state machine after the reception or transmission of a frame.

This field is also encoded in the **CANINT** register.

The **CANMSG1INT** register contains the **INTPND** bits of the first 16 message objects in the message RAM; the **CANMSG2INT** register contains the **INTPND** bits of the second 16 message objects.

CAN Message n Interrupt Pending (CANMSGnINT)

CAN0 base: 0x4004.0000
 CAN1 base: 0x4004.1000
 Offset 0x140
 Type RO, reset 0x0000.0000

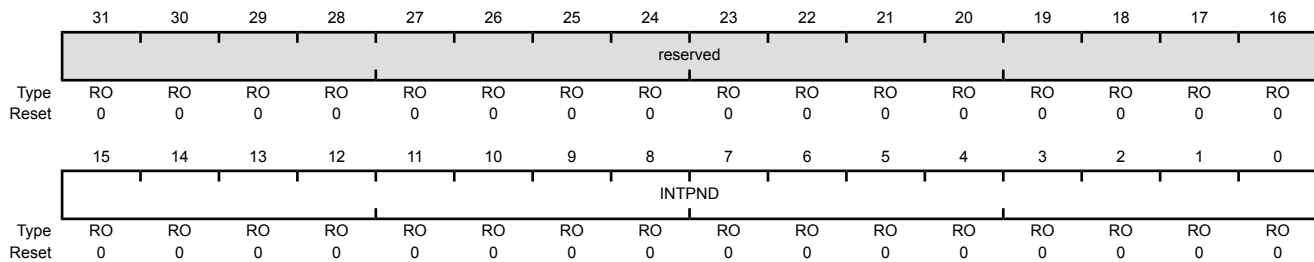

Bit/Field	Name	Type	Reset	Description
31:16	reserved	RO	0x0000	Software should not rely on the value of a reserved bit. To provide compatibility with future products, the value of a reserved bit should be preserved across a read-modify-write operation.
15:0	INTPND	RO	0x0000	Interrupt Pending Bits
			Value	Description
			0	The corresponding message object is not the source of an interrupt.
			1	The corresponding message object is the source of an interrupt.

Register 36: CAN Message 1 Valid (CANMSG1VAL), offset 0x160

Register 37: CAN Message 2 Valid (CANMSG2VAL), offset 0x164

The **CANMSG1VAL** and **CANMSG2VAL** registers hold the **MSGVAL** bits of the 32 message objects. By reading these bits, the CPU can check which message object is valid. The message valid bit of a specific message object can be changed with the **CANIFnARB2** register.

The **CANMSG1VAL** register contains the **MSGVAL** bits of the first 16 message objects in the message RAM; the **CANMSG2VAL** register contains the **MSGVAL** bits of the second 16 message objects in the message RAM.

CAN Message n Valid (CANMSGnVAL)

CAN0 base: 0x4004.0000
 CAN1 base: 0x4004.1000
 Offset 0x160
 Type RO, reset 0x0000.0000

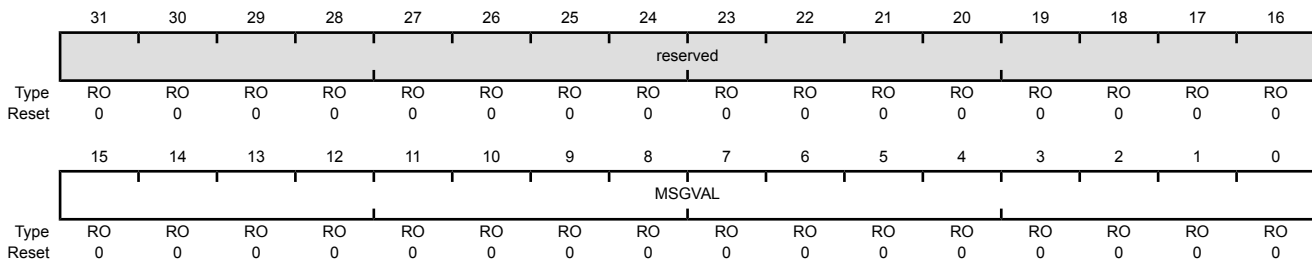

Bit/Field	Name	Type	Reset	Description
31:16	reserved	RO	0x0000	Software should not rely on the value of a reserved bit. To provide compatibility with future products, the value of a reserved bit should be preserved across a read-modify-write operation.
15:0	MSGVAL	RO	0x0000	Message Valid Bits
				Value Description
				0 The corresponding message object is not configured and is ignored by the message handler.
				1 The corresponding message object is configured and should be considered by the message handler.

17 Universal Serial Bus (USB) Controller

The Stellaris® USB controller operates as a full-speed or low-speed function controller during point-to-point communications with USB Host, Device, or OTG functions. The controller complies with the USB 2.0 standard, which includes SUSPEND and RESUME signaling. 16 endpoints including two hard-wired for control transfers (one endpoint for IN and one endpoint for OUT) plus 14 endpoints defined by firmware along with a dynamic sizable FIFO support multiple packet queueing. μ DMA access to the FIFO allows minimal interference from system software. Software-controlled connect and disconnect allows flexibility during USB device start-up. The controller complies with OTG standard's session request protocol (SRP) and host negotiation protocol (HNP).

The Stellaris USB module has the following features:

- Complies with USB-IF certification standards
- USB 2.0 full-speed (12 Mbps) and low-speed (1.5 Mbps) operation with integrated PHY
- 4 transfer types: Control, Interrupt, Bulk, and Isochronous
- 16 endpoints
 - 1 dedicated control IN endpoint and 1 dedicated control OUT endpoint
 - 7 configurable IN endpoints and 7 configurable OUT endpoints
- 4 KB dedicated endpoint memory: one endpoint may be defined for double-buffered 1023-byte isochronous packet size
- VBUS droop and valid ID detection and interrupt
- Efficient transfers using Micro Direct Memory Access Controller (μ DMA)
 - Separate channels for transmit and receive for up to three IN endpoints and three OUT endpoints
 - Channel requests asserted when FIFO contains required amount of data

17.1 Block Diagram

Figure 17-1. USB Module Block Diagram

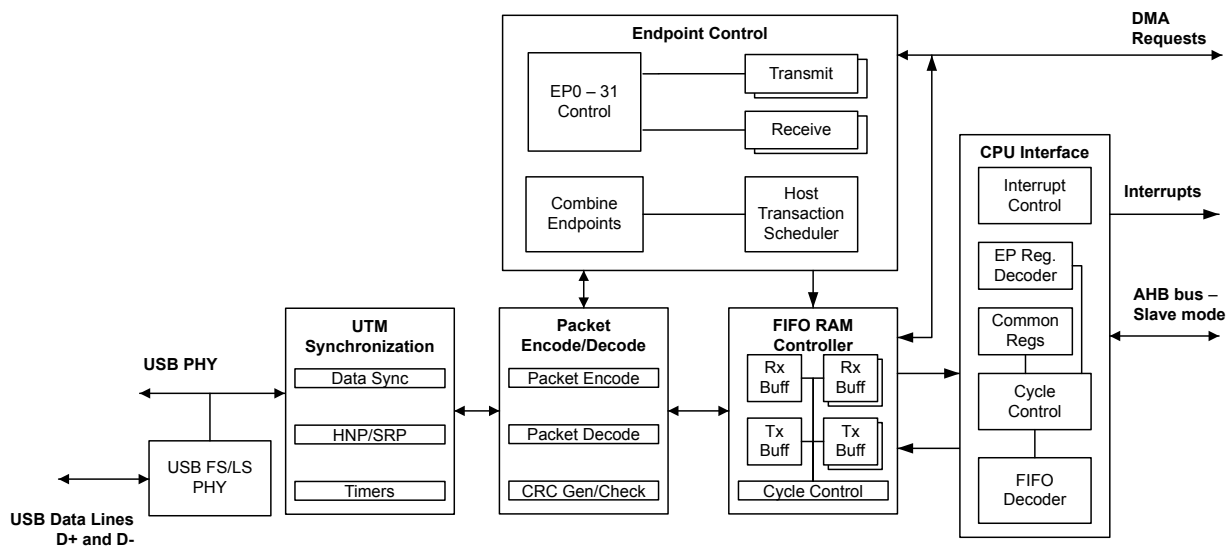

17.2 Signal Description

The following table lists the external signals of the USB controller and describes the function of each. Some USB controller signals are alternate functions for some GPIO signals and default to be GPIO signals at reset. The column in the table below titled "Pin Mux/Pin Assignment" lists the possible GPIO pin placements for these USB signals. The `AFSEL` bit in the **GPIO Alternate Function Select (GPIOAFSEL)** register (page 644) should be set to choose the USB function. The number in parentheses is the encoding that must be programmed into the `PMCn` field in the **GPIO Port Control (GPIOPCTL)** register (page 661) to assign the USB signal to the specified GPIO port pin. The `USB0VBUS` and `USB0ID` signals are configured by clearing the appropriate `DEN` bit in the **GPIO Digital Enable (GPIODEN)** register. For more information on configuring GPIOs, see "General-Purpose Input/Outputs (GPIOs)" on page 623. The remaining signals (with the word "fixed" in the Pin Mux/Pin Assignment column) have a fixed pin assignment and function.

Note: When used in OTG mode, `USB0VBUS` and `USB0ID` do not require any configuration as they are dedicated pins for the USB controller and directly connect to the USB connector's VBUS and ID signals. If the USB controller is used as either a dedicated Host or Device, the `DEVMODOTG` and `DEVMOD` bits in the **USB General-Purpose Control and Status (USBGPCS)** register can be used to connect the `USB0VBUS` and `USB0ID` inputs to fixed levels internally, freeing the `PB0` and `PB1` pins for GPIO use. For proper self-powered Device operation, the VBUS value must still be monitored to assure that if the Host removes VBUS, the self-powered Device disables the D+/D- pull-up resistors. This function can be accomplished by connecting a standard GPIO to VBUS.

Table 17-1. USB Signals (64LQFP)

Pin Name	Pin Number	Pin Mux / Pin Assignment	Pin Type	Buffer Type ^a	Description
USB0DM	43	PD4	I/O	Analog	Bidirectional differential data pin (D- per USB specification) for USB0.

Table 17-1. USB Signals (64LQFP) (continued)

Pin Name	Pin Number	Pin Mux / Pin Assignment	Pin Type	Buffer Type ^a	Description
USB0DP	44	PD5	I/O	Analog	Bidirectional differential data pin (D+ per USB specification) for USB0.
USB0EPEN	5 14 33 63	PF4 (8) PC6 (8) PG4 (8) PD2 (8)	O	TTL	Optionally used in Host mode to control an external power source to supply power to the USB bus.
USB0ID	45	PB0	I	Analog	This signal senses the state of the USB ID signal. The USB PHY enables an integrated pull-up, and an external element (USB connector) indicates the initial state of the USB controller (pulled down is the A side of the cable and pulled up is the B side).
USB0PFLT	13 32 64	PC7 (8) PG5 (8) PD3 (8)	I	TTL	Optionally used in Host mode by an external power source to indicate an error state by that power source.
USB0VBUS	46	PB1	I/O	Analog	This signal is used during the session request protocol. This signal allows the USB PHY to both sense the voltage level of VBUS, and pull up VBUS momentarily during VBUS pulsing.

a. The TTL designation indicates the pin has TTL-compatible voltage levels.

17.3 Functional Description

The Stellaris USB controller provides full OTG negotiation by supporting both the session request protocol (SRP) and the host negotiation protocol (HNP). The session request protocol allows devices on the B side of a cable to request the A side device turn on VBUS. The host negotiation protocol is used after the initial session request protocol has powered the bus and provides a method to determine which end of the cable will act as the Host controller. When the device is connected to non-OTG peripherals or devices, the controller can detect which cable end was used and provides a register to indicate if the controller should act as the Host or the Device controller. This indication and the mode of operation are handled automatically by the USB controller. This auto-detection allows the system to use a single A/B connector instead of having both A and B connectors in the system and supports full OTG negotiations with other OTG devices.

In addition, the USB controller provides support for connecting to non-OTG peripherals or Host controllers. The USB controller can be configured to act as either a dedicated Host or Device, in which case, the `USB0VBUS` and `USB0ID` signals can be used as GPIOs. However, when the USB controller is acting as a self-powered Device, a GPIO input or analog comparator input must be connected to VBUS and configured to generate an interrupt when the VBUS level drops. This interrupt is used to disable the pullup resistor on the `USB0DP` signal.

Note: When the USB module is in operation, MOSC must be the clock source, either with or without using the PLL, and the system clock must be at least 30 MHz.

17.3.1 Operation as a Device

This section describes the Stellaris USB controller's actions when it is being used as a USB Device. Before the USB controller's operating mode is changed from Device to Host or Host to Device, software must reset the USB controller by setting the `USB0` bit in the **Software Reset Control 2 (SRCR2)** register (see page 461). IN endpoints, OUT endpoints, entry into and exit from SUSPEND mode, and recognition of Start of Frame (SOF) are all described.

When in Device mode, IN transactions are controlled by an endpoint's transmit interface and use the transmit endpoint registers for the given endpoint. OUT transactions are handled with an endpoint's receive interface and use the receive endpoint registers for the given endpoint.

When configuring the size of the FIFOs for endpoints, take into account the maximum packet size for an endpoint.

- **Bulk.** Bulk endpoints should be the size of the maximum packet (up to 64 bytes) or twice the maximum packet size if double buffering is used (described further in the following section).
- **Interrupt.** Interrupt endpoints should be the size of the maximum packet (up to 64 bytes) or twice the maximum packet size if double buffering is used.
- **Isochronous.** Isochronous endpoints are more flexible and can be up to 1023 bytes.
- **Control.** It is also possible to specify a separate control endpoint for a USB Device. However, in most cases the USB Device should use the dedicated control endpoint on the USB controller's endpoint 0.

17.3.1.1 Endpoints

When operating as a Device, the USB controller provides two dedicated control endpoints (IN and OUT) and 14 configurable endpoints (7 IN and 7 OUT) that can be used for communications with a Host controller. The endpoint number and direction associated with an endpoint is directly related to its register designation. For example, when the Host is transmitting to endpoint 1, all configuration and data is in the endpoint 1 transmit register interface.

Endpoint 0 is a dedicated control endpoint used for all control transactions to endpoint 0 during enumeration or when any other control requests are made to endpoint 0. Endpoint 0 uses the first 64 bytes of the USB controller's FIFO RAM as a shared memory for both IN and OUT transactions.

The remaining 14 endpoints can be configured as control, bulk, interrupt, or isochronous endpoints. They should be treated as 7 configurable IN and 7 configurable OUT endpoints. The endpoint pairs are not required to have the same type for their IN and OUT endpoint configuration. For example, the OUT portion of an endpoint pair could be a bulk endpoint, while the IN portion of that endpoint pair could be an interrupt endpoint. The address and size of the FIFOs attached to each endpoint can be modified to fit the application's needs.

17.3.1.2 IN Transactions as a Device

When operating as a USB Device, data for IN transactions is handled through the FIFOs attached to the transmit endpoints. The sizes of the FIFOs for the 7 configurable IN endpoints are determined by the **USB Transmit FIFO Start Address (USBTXFIFOADD)** register. The maximum size of a data packet that may be placed in a transmit endpoint's FIFO for transmission is programmable and is determined by the value written to the **USB Maximum Transmit Data Endpoint n (USBTXMAXPn)** register for that endpoint. The endpoint's FIFO can also be configured to use double-packet or single-packet buffering. When double-packet buffering is enabled, two data packets can be buffered in the FIFO, which also requires that the FIFO is at least two packets in size. When double-packet buffering is disabled, only one packet can be buffered, even if the packet size is less than half the FIFO size.

Note: The maximum packet size set for any endpoint must not exceed the FIFO size. The **USBTXMAXPn** register should not be written to while data is in the FIFO as unexpected results may occur.

Single-Packet Buffering

If the size of the transmit endpoint's FIFO is less than twice the maximum packet size for this endpoint (as set in the **USB Transmit Dynamic FIFO Sizing (USBTXFIFOSZ)** register), only one packet can be buffered in the FIFO and single-packet buffering is required. When each packet is completely loaded into the transmit FIFO, the **TXRDY** bit in the **USB Transmit Control and Status Endpoint n Low (USBTXCSRLn)** register must be set. If the **AUTOSET** bit in the **USB Transmit Control and Status Endpoint n High (USBTXCSRHn)** register is set, the **TXRDY** bit is automatically set when a maximum-sized packet is loaded into the FIFO. For packet sizes less than the maximum, the **TXRDY** bit must be set manually. When the **TXRDY** bit is set, either manually or automatically, the packet is ready to be sent. When the packet has been successfully sent, both **TXRDY** and **FIFONE** are cleared, and the appropriate transmit endpoint interrupt signaled. At this point, the next packet can be loaded into the FIFO.

Double-Packet Buffering

If the size of the transmit endpoint's FIFO is at least twice the maximum packet size for this endpoint, two packets can be buffered in the FIFO and double-packet buffering is allowed. As each packet is loaded into the transmit FIFO, the **TXRDY** bit in the **USBTXCSRLn** register must be set. If the **AUTOSET** bit in the **USBTXCSRHn** register is set, the **TXRDY** bit is automatically set when a maximum-sized packet is loaded into the FIFO. For packet sizes less than the maximum, **TXRDY** must be set manually. When the **TXRDY** bit is set, either manually or automatically, the packet is ready to be sent. After the first packet is loaded, **TXRDY** is immediately cleared and an interrupt is generated. A second packet can now be loaded into the transmit FIFO and **TXRDY** set again (either manually or automatically if the packet is the maximum size). At this point, both packets are ready to be sent. After each packet has been successfully sent, **TXRDY** is automatically cleared and the appropriate transmit endpoint interrupt signaled to indicate that another packet can now be loaded into the transmit FIFO. The state of the **FIFONE** bit in the **USBTXCSRLn** register at this point indicates how many packets may be loaded. If the **FIFONE** bit is set, then another packet is in the FIFO and only one more packet can be loaded. If the **FIFONE** bit is clear, then no packets are in the FIFO and two more packets can be loaded.

Note: Double-packet buffering is disabled if an endpoint's corresponding **EPn** bit is set in the **USB Transmit Double Packet Buffer Disable (USBTXDPKTBUFDIS)** register. This bit is set by default, so it must be cleared to enable double-packet buffering.

17.3.1.3 OUT Transactions as a Device

When in Device mode, OUT transactions are handled through the USB controller receive FIFOs. The sizes of the receive FIFOs for the 7 configurable OUT endpoints are determined by the **USB Receive FIFO Start Address (USBRXFIFOADD)** register. The maximum amount of data received by an endpoint in any packet is determined by the value written to the **USB Maximum Receive Data Endpoint n (USBRXMAXPn)** register for that endpoint. When double-packet buffering is enabled, two data packets can be buffered in the FIFO. When double-packet buffering is disabled, only one packet can be buffered even if the packet is less than half the FIFO size.

Note: In all cases, the maximum packet size must not exceed the FIFO size.

Single-Packet Buffering

If the size of the receive endpoint FIFO is less than twice the maximum packet size for an endpoint, only one data packet can be buffered in the FIFO and single-packet buffering is required. When a packet is received and placed in the receive FIFO, the **RXRDY** and **FULL** bits in the **USB Receive Control and Status Endpoint n Low (USBRXCSRLn)** register are set and the appropriate receive endpoint is signaled, indicating that a packet can now be unloaded from the FIFO. After the packet

has been unloaded, the `RXRDY` bit must be cleared in order to allow further packets to be received. This action also generates the acknowledge signaling to the Host controller. If the `AUTOCL` bit in the **USB Receive Control and Status Endpoint n High (USBXCSRHn)** register is set and a maximum-sized packet is unloaded from the FIFO, the `RXRDY` and `FULL` bits are cleared automatically. For packet sizes less than the maximum, `RXRDY` must be cleared manually.

Double-Packet Buffering

If the size of the receive endpoint FIFO is at least twice the maximum packet size for the endpoint, two data packets can be buffered and double-packet buffering can be used. When the first packet is received and loaded into the receive FIFO, the `RXRDY` bit in the **USBXCSRLn** register is set and the appropriate receive endpoint interrupt is signaled to indicate that a packet can now be unloaded from the FIFO.

Note: The `FULL` bit in **USBXCSRLn** is not set when the first packet is received. It is only set if a second packet is received and loaded into the receive FIFO.

After each packet has been unloaded, the `RXRDY` bit must be cleared to allow further packets to be received. If the `AUTOCL` bit in the **USBXCSRHn** register is set and a maximum-sized packet is unloaded from the FIFO, the `RXRDY` bit is cleared automatically. For packet sizes less than the maximum, `RXRDY` must be cleared manually. If the `FULL` bit is set when `RXRDY` is cleared, the USB controller first clears the `FULL` bit, then sets `RXRDY` again to indicate that there is another packet waiting in the FIFO to be unloaded.

Note: Double-packet buffering is disabled if an endpoint's corresponding `EPn` bit is set in the **USB Receive Double Packet Buffer Disable (USBXDPKTBUFDIS)** register. This bit is set by default, so it must be cleared to enable double-packet buffering.

17.3.1.4 Scheduling

The Device has no control over the scheduling of transactions as scheduling is determined by the Host controller. The Stellaris USB controller can set up a transaction at any time. The USB controller waits for the request from the Host controller and generates an interrupt when the transaction is complete or if it was terminated due to some error. If the Host controller makes a request and the Device controller is not ready, the USB controller sends a busy response (NAK) to all requests until it is ready.

17.3.1.5 Additional Actions

The USB controller responds automatically to certain conditions on the USB bus or actions by the Host controller such as when the USB controller automatically stalls a control transfer or unexpected zero length OUT data packets.

Stalled Control Transfer

The USB controller automatically issues a STALL handshake to a control transfer under the following conditions:

1. The Host sends more data during an OUT data phase of a control transfer than was specified in the Device request during the SETUP phase. This condition is detected by the USB controller when the Host sends an OUT token (instead of an IN token) after the last OUT packet has been unloaded and the `DATAEND` bit in the **USB Control and Status Endpoint 0 Low (USBCSRL0)** register has been set.
2. The Host requests more data during an IN data phase of a control transfer than was specified in the Device request during the SETUP phase. This condition is detected by the USB controller

when the Host sends an IN token (instead of an OUT token) after the CPU has cleared `TXRDY` and set `DATAEND` in response to the ACK issued by the Host to what should have been the last packet.

3. The Host sends more than **USBRXMAXPn** bytes of data with an OUT data token.
4. The Host sends more than a zero length data packet for the OUT STATUS phase.

Zero Length OUT Data Packets

A zero-length OUT data packet is used to indicate the end of a control transfer. In normal operation, such packets should only be received after the entire length of the Device request has been transferred.

However, if the Host sends a zero-length OUT data packet before the entire length of Device request has been transferred, it is signaling the premature end of the transfer. In this case, the USB controller automatically flushes any IN token ready for the data phase from the FIFO and sets the `DATAEND` bit in the **USBCSRL0** register.

Setting the Device Address

When a Host is attempting to enumerate the USB Device, it requests that the Device change its address from zero to some other value. The address is changed by writing the value that the Host requested to the **USB Device Functional Address (USBFADDR)** register. However, care should be taken when writing to **USBFADDR** to avoid changing the address before the transaction is complete. This register should only be set after the `SET_ADDRESS` command is complete. Like all control transactions, the transaction is only complete after the Device has left the STATUS phase. In the case of a `SET_ADDRESS` command, the transaction is completed by responding to the IN request from the Host with a zero-byte packet. Once the Device has responded to the IN request, the **USBFADDR** register should be programmed to the new value as soon as possible to avoid missing any new commands sent to the new address.

Note: If the **USBFADDR** register is set to the new value as soon as the Device receives the OUT transaction with the `SET_ADDRESS` command in the packet, it changes the address during the control transfer. In this case, the Device does not receive the IN request that allows the USB transaction to exit the STATUS phase of the control transfer because it is sent to the old address. As a result, the Host does not get a response to the IN request, and the Host fails to enumerate the Device.

17.3.1.6 Device Mode SUSPEND

When no activity has occurred on the USB bus for 3 ms, the USB controller automatically enters SUSPEND mode. If the SUSPEND interrupt has been enabled in the **USB Interrupt Enable (USBIE)** register, an interrupt is generated at this time. When in SUSPEND mode, the PHY also goes into SUSPEND mode. When RESUME signaling is detected, the USB controller exits SUSPEND mode and takes the PHY out of SUSPEND. If the RESUME interrupt is enabled, an interrupt is generated. The USB controller can also be forced to exit SUSPEND mode by setting the `RESUME` bit in the **USB Power (USBPOWER)** register. When this bit is set, the USB controller exits SUSPEND mode and drives RESUME signaling onto the bus. The `RESUME` bit must be cleared after 10 ms (a maximum of 15 ms) to end RESUME signaling.

To meet USB power requirements, the controller can be put into Deep Sleep mode which keeps the controller in a static state.

17.3.1.7 Start-of-Frame

When the USB controller is operating in Device mode, it receives a Start-Of-Frame (SOF) packet from the Host once every millisecond. When the SOF packet is received, the 11-bit frame number contained in the packet is written into the **USB Frame Value (USBFRAME)** register, and an SOF interrupt is also signaled and can be handled by the application. Once the USB controller has started to receive SOF packets, it expects one every millisecond. If no SOF packet is received after 1.00358 ms, the packet is assumed to have been lost, and the **USBFRAME** register is not updated. The USB controller continues and resynchronizes these pulses to the received SOF packets when these packets are successfully received again.

17.3.1.8 USB RESET

When the USB controller is in Device mode and a RESET condition is detected on the USB bus, the USB controller automatically performs the following actions:

- Clears the **USBFADDR** register.
- Clears the **USB Endpoint Index (USBEPIDX)** register.
- Flushes all endpoint FIFOs.
- Clears all control/status registers.
- Enables all endpoint interrupts.
- Generates a RESET interrupt.

When the application software driving the USB controller receives a RESET interrupt, any open pipes are closed and the USB controller waits for bus enumeration to begin.

17.3.1.9 Connect/Disconnect

The USB controller connection to the USB bus is handled by software. The USB PHY can be switched between normal mode and non-driving mode by setting or clearing the **SOFTCONN** bit of the **USBPOWER** register. When the **SOFTCONN** bit is set, the PHY is placed in its normal mode, and the **USB0DP/USB0DM** lines of the USB bus are enabled. At the same time, the USB controller is placed into a state, in which it does not respond to any USB signaling except a USB RESET.

When the **SOFTCONN** bit is cleared, the PHY is put into non-driving mode, **USB0DP** and **USB0DM** are tristated, and the USB controller appears to other devices on the USB bus as if it has been disconnected. The non-driving mode is the default so the USB controller appears disconnected until the **SOFTCONN** bit has been set. The application software can then choose when to set the PHY into its normal mode. Systems with a lengthy initialization procedure may use this to ensure that initialization is complete, and the system is ready to perform enumeration before connecting to the USB bus. Once the **SOFTCONN** bit has been set, the USB controller can be disconnected by clearing this bit.

Note: The USB controller does not generate an interrupt when the Device is connected to the Host. However, an interrupt is generated when the Host terminates a session.

17.3.2 Operation as a Host

When the Stellaris USB controller is operating in Host mode, it can either be used for point-to-point communications with another USB device or, when attached to a hub, for communication with multiple devices. Before the USB controller's operating mode is changed from Host to Device or

Device to Host, software must reset the USB controller by setting the `USB0` bit in the **Software Reset Control 2 (SRCR2)** register (see page 461). Full-speed and low-speed USB devices are supported, both for point-to-point communication and for operation through a hub. The USB controller automatically carries out the necessary transaction translation needed to allow a low-speed or full-speed device to be used with a USB 2.0 hub. Control, bulk, isochronous, and interrupt transactions are supported. This section describes the USB controller's actions when it is being used as a USB Host. Configuration of IN endpoints, OUT endpoints, entry into and exit from SUSPEND mode, and RESET are all described.

When in Host mode, IN transactions are controlled by an endpoint's receive interface. All IN transactions use the receive endpoint registers and all OUT endpoints use the transmit endpoint registers for a given endpoint. As in Device mode, the FIFOs for endpoints should take into account the maximum packet size for an endpoint.

- **Bulk.** Bulk endpoints should be the size of the maximum packet (up to 64 bytes) or twice the maximum packet size if double buffering is used (described further in the following section).
- **Interrupt.** Interrupt endpoints should be the size of the maximum packet (up to 64 bytes) or twice the maximum packet size if double buffering is used.
- **Isochronous.** Isochronous endpoints are more flexible and can be up to 1023 bytes.
- **Control.** It is also possible to specify a separate control endpoint to communicate with a Device. However, in most cases the USB controller should use the dedicated control endpoint to communicate with a Device's endpoint 0.

17.3.2.1 Endpoints

The endpoint registers are used to control the USB endpoint interfaces which communicate with Device(s) that are connected. The endpoints consist of a dedicated control IN endpoint, a dedicated control OUT endpoint, 7 configurable OUT endpoints, and 7 configurable IN endpoints.

The dedicated control interface can only be used for control transactions to endpoint 0 of Devices. These control transactions are used during enumeration or other control functions that communicate using endpoint 0 of Devices. This control endpoint shares the first 64 bytes of the USB controller's FIFO RAM for IN and OUT transactions. The remaining IN and OUT interfaces can be configured to communicate with control, bulk, interrupt, or isochronous Device endpoints.

These USB interfaces can be used to simultaneously schedule as many as 7 independent OUT and 7 independent IN transactions to any endpoints on any Device. The IN and OUT controls are paired in three sets of registers. However, they can be configured to communicate with different types of endpoints and different endpoints on Devices. For example, the first pair of endpoint controls can be split so that the OUT portion is communicating with a Device's bulk OUT endpoint 1, while the IN portion is communicating with a Device's interrupt IN endpoint 2.

Before accessing any Device, whether for point-to-point communications or for communications via a hub, the relevant **USB Receive Functional Address Endpoint n (USBRXFUNCADDRn)** or **USB Transmit Functional Address Endpoint n (USBTXFUNCADDRn)** registers must be set for each receive or transmit endpoint to record the address of the Device being accessed.

The USB controller also supports connections to Devices through a USB hub by providing a register that specifies the hub address and port of each USB transfer. The FIFO address and size are customizable and can be specified for each USB IN and OUT transfer. Customization includes allowing one FIFO per transaction, sharing a FIFO across transactions, and allowing for double-buffered FIFOs.

17.3.2.2 IN Transactions as a Host

IN transactions are handled in a similar manner to the way in which OUT transactions are handled when the USB controller is in Device mode except that the transaction first must be initiated by setting the `REQPKT` bit in the **USBCSRL0** register, indicating to the transaction scheduler that there is an active transaction on this endpoint. The transaction scheduler then sends an IN token to the target Device. When the packet is received and placed in the receive FIFO, the `RXRDY` bit in the **USBCSRL0** register is set, and the appropriate receive endpoint interrupt is signaled to indicate that a packet can now be unloaded from the FIFO.

When the packet has been unloaded, `RXRDY` must be cleared. The `AUTOCL` bit in the **USBXCSRHn** register can be used to have `RXRDY` automatically cleared when a maximum-sized packet has been unloaded from the FIFO. The `AUTORQ` bit in **USBXCSRHn** causes the `REQPKT` bit to be automatically set when the `RXRDY` bit is cleared. The `AUTOCL` and `AUTORQ` bits can be used with μ DMA accesses to perform complete bulk transfers without main processor intervention. When the `RXRDY` bit is cleared, the controller sends an acknowledge to the Device. When there is a known number of packets to be transferred, the **USB Request Packet Count in Block Transfer Endpoint n (USBRQPKTCOUNTn)** register associated with the endpoint should be configured to the number of packets to be transferred. The USB controller decrements the value in the **USBRQPKTCOUNTn** register following each request. When the **USBRQPKTCOUNTn** value decrements to 0, the `AUTORQ` bit is cleared to prevent any further transactions being attempted. For cases where the size of the transfer is unknown, **USBRQPKTCOUNTn** should be cleared. `AUTORQ` then remains set until cleared by the reception of a short packet (that is, less than the `MAXLOAD` value in the **USBXMAXPn** register) such as may occur at the end of a bulk transfer.

If the Device responds to a bulk or interrupt IN token with a NAK, the USB Host controller keeps retrying the transaction until any NAK Limit that has been set has been reached. If the target Device responds with a STALL, however, the USB Host controller does not retry the transaction but sets the `STALLED` bit in the **USBCSRL0** register. If the target Device does not respond to the IN token within the required time, or the packet contained a CRC or bit-stuff error, the USB Host controller retries the transaction. If after three attempts the target Device has still not responded, the USB Host controller clears the `REQPKT` bit and sets the `ERROR` bit in the **USBCSRL0** register.

17.3.2.3 OUT Transactions as a Host

OUT transactions are handled in a similar manner to the way in which IN transactions are handled when the USB controller is in Device mode. The `TXRDY` bit in the **USBTXCSRLn** register must be set as each packet is loaded into the transmit FIFO. Again, setting the `AUTOSET` bit in the **USBTXCSRHn** register automatically sets `TXRDY` when a maximum-sized packet has been loaded into the FIFO. Furthermore, `AUTOSET` can be used with the μ DMA controller to perform complete bulk transfers without software intervention.

If the target Device responds to the OUT token with a NAK, the USB Host controller keeps retrying the transaction until the NAK Limit that has been set has been reached. However, if the target Device responds with a STALL, the USB controller does not retry the transaction but interrupts the main processor by setting the `STALLED` bit in the **USBTXCSRLn** register. If the target Device does not respond to the OUT token within the required time, or the packet contained a CRC or bit-stuff error, the USB Host controller retries the transaction. If after three attempts the target Device has still not responded, the USB controller flushes the FIFO and sets the `ERROR` bit in the **USBTXCSRLn** register.

17.3.2.4 Transaction Scheduling

Scheduling of transactions is handled automatically by the USB Host controller. The Host controller allows configuration of the endpoint communication scheduling based on the type of endpoint transaction. Interrupt transactions can be scheduled to occur in the range of every frame to every

255 frames in 1 frame increments. Bulk endpoints do not allow scheduling parameters, but do allow for a NAK timeout in the event an endpoint on a Device is not responding. Isochronous endpoints can be scheduled from every frame to every 2^{16} frames, in powers of 2.

The USB controller maintains a frame counter. If the target Device is a full-speed device, the USB controller automatically sends an SOF packet at the start of each frame and increments the frame counter. If the target Device is a low-speed device, a *K* state is transmitted on the bus to act as a *keep-alive* to stop the low-speed device from going into SUSPEND mode.

After the SOF packet has been transmitted, the USB Host controller cycles through all the configured endpoints looking for active transactions. An active transaction is defined as a receive endpoint for which the `REQPKT` bit is set or a transmit endpoint for which the `TXRDY` bit and/or the `FIFONE` bit is set.

An isochronous or interrupt transaction is started if the transaction is found on the first scheduler cycle of a frame and if the interval counter for that endpoint has counted down to zero. As a result, only one interrupt or isochronous transaction occurs per endpoint every *n* frames, where *n* is the interval set via the **USB Host Transmit Interval Endpoint *n* (USBTXINTERVAL_n)** or **USB Host Receive Interval Endpoint *n* (USBRXINTERVAL_n)** register for that endpoint.

An active bulk transaction starts immediately, provided sufficient time is left in the frame to complete the transaction before the next SOF packet is due. If the transaction must be retried (for example, because a NAK was received or the target Device did not respond), then the transaction is not retried until the transaction scheduler has first checked all the other endpoints for active transactions. This process ensures that an endpoint that is sending a lot of NAKs does not block other transactions on the bus. The controller also allows the user to specify a limit to the length of time for NAKs to be received from a target Device before the endpoint times out.

17.3.2.5 USB Hubs

The following setup requirements apply to the USB Host controller only if it is used with a USB hub. When a full- or low-speed Device is connected to the USB controller via a USB 2.0 hub, details of the hub address and the hub port also must be recorded in the corresponding **USB Receive Hub Address Endpoint *n* (USBRXHUBADDR_n)** and **USB Receive Hub Port Endpoint *n* (USBRXHUBPORT_n)** or the **USB Transmit Hub Address Endpoint *n* (USBTXHUBADDR_n)** and **USB Transmit Hub Port Endpoint *n* (USBTXHUBPORT_n)** registers. In addition, the speed at which the Device operates (full or low) must be recorded in the **USB Type Endpoint 0 (USBTYPEn)** (endpoint 0), **USB Host Configure Transmit Type Endpoint *n* (USBTXTYPEn)**, or **USB Host Configure Receive Type Endpoint *n* (USBRXTYPEn)** registers for each endpoint that is accessed by the Device.

For hub communications, the settings in these registers record the current allocation of the endpoints to the attached USB Devices. To maximize the number of Devices supported, the USB Host controller allows this allocation to be changed dynamically by simply updating the address and speed information recorded in these registers. Any changes in the allocation of endpoints to Device functions must be made following the completion of any on-going transactions on the endpoints affected.

17.3.2.6 Babble

The USB Host controller does not start a transaction until the bus has been inactive for at least the minimum inter-packet delay. The controller also does not start a transaction unless it can be finished before the end of the frame. If the bus is still active at the end of a frame, then the USB Host controller assumes that the target Device to which it is connected has malfunctioned, and the USB controller suspends all transactions and generates a babble interrupt.

17.3.2.7 Host SUSPEND

If the `SUSPEND` bit in the **USBPOWER** register is set, the USB Host controller completes the current transaction then stops the transaction scheduler and frame counter. No further transactions are started and no SOF packets are generated.

To exit SUSPEND mode, set the `RESUME` bit and clear the `SUSPEND` bit. While the `RESUME` bit is set, the USB Host controller generates RESUME signaling on the bus. After 20 ms, the `RESUME` bit must be cleared, at which point the frame counter and transaction scheduler start. The Host supports the detection of a remote wake-up.

17.3.2.8 USB RESET

If the `RESET` bit in the **USBPOWER** register is set, the USB Host controller generates USB RESET signaling on the bus. The `RESET` bit must be set for at least 20 ms to ensure correct resetting of the target Device. After the CPU has cleared the bit, the USB Host controller starts its frame counter and transaction scheduler.

17.3.2.9 Connect/Disconnect

A session is started by setting the `SESSION` bit in the **USB Device Control (USBDEVCTL)** register, enabling the USB controller to wait for a Device to be connected. When a Device is detected, a connect interrupt is generated. The speed of the Device that has been connected can be determined by reading the **USBDEVCTL** register where the `FSDEV` bit is set for a full-speed Device, and the `LSDEV` bit is set for a low-speed Device. The USB controller must generate a RESET to the Device, and then the USB Host controller can begin Device enumeration. If the Device is disconnected while a session is in progress, a disconnect interrupt is generated.

17.3.3 OTG Mode

To conserve power, the USB On-The-Go (OTG) supplement allows VBUS to only be powered up when required and to be turned off when the bus is not in use. VBUS is always supplied by the A device on the bus. The USB OTG controller determines whether it is the A device or the B device by sampling the ID input from the PHY. This signal is pulled Low when an A-type plug is sensed (signifying that the USB OTG controller should act as the A device) but taken High when a B-type plug is sensed (signifying that the USB controller is a B device). Note that when switching between OTG A and OTG B, the USB controller retains all register contents.

17.3.3.1 Starting a Session

When the USB OTG controller is ready to start a session, the `SESSION` bit must be set in the **USBDEVCTL** register. The USB OTG controller then enables ID pin sensing. The ID input is either taken Low if an A-type connection is detected or High if a B-type connection is detected. The `DEV` bit in the **USBDEVCTL** register is also set to indicate whether the USB OTG controller has adopted the role of the A device or the B device. The USB OTG controller also provides an interrupt to indicate that ID pin sensing has completed and the mode value in the **USBDEVCTL** register is valid. This interrupt is enabled in the **USBIDVIM** register, and the status is checked in the **USBIDVISC** register. As soon as the USB controller has detected that it is on the A side of the cable, it must enable VBUS power within 100ms or the USB controller reverts to Device mode.

If the USB OTG controller is the A device, then the USB OTG controller enters Host mode (the A device is always the default Host), turns on VBUS, and waits for VBUS to go above the VBUS Valid threshold, as indicated by the `VBUS` bit in the **USBDEVCTL** register going to 0x3. The USB OTG controller then waits for a peripheral to be connected. When a peripheral is detected, a Connect interrupt is signaled and either the `FSDEV` or `LSDEV` bit in the **USBDEVCTL** register is set, depending whether a full-speed or a low-speed peripheral is detected. The USB controller then issues a RESET

to the connected Device. The `SESSION` bit in the `USBDEVCTL` register can be cleared to end a session. The USB OTG controller also automatically ends the session if babble is detected or if VBUS drops below session valid.

Note: The USB OTG controller may not remain in Host mode when connected to high-current devices. Some devices draw enough current to momentarily drop VBUS below the VBUS-valid level causing the controller to drop out of Host mode. The only way to get back into Host mode is to allow VBUS to go below the Session End level. In this situation, the device is causing VBUS to drop repeatedly and pull VBUS back low the next time VBUS is enabled.

In addition, the USB OTG controller may not remain in Host mode when a device is told that it can start using its active configuration. At this point the device starts drawing more current and can also drop VBUS below VBUS valid.

If the USB OTG controller is the B device, then the USB OTG controller requests a session using the session request protocol defined in the USB On-The-Go supplement, that is, it first discharges VBUS. Then when VBUS has gone below the Session End threshold (`VBUS` bit in the `USBDEVCTL` register goes to 0x0) and the line state has been a single-ended zero for > 2 ms, the USB OTG controller pulses the data line, then pulses VBUS. At the end of the session, the `SESSION` bit is cleared either by the USB OTG controller or by the application software. The USB OTG controller then causes the PHY to switch out the pull-up resistor on D+, signaling the A device to end the session.

17.3.3.2 Detecting Activity

When the other device of the OTG setup wishes to start a session, it either raises VBUS above the Session Valid threshold if it is the A device, or if it is the B device, it pulses the data line then pulses VBUS. Depending on which of these actions happens, the USB controller can determine whether it is the A device or the B device in the current setup and act accordingly. If VBUS is raised above the Session Valid threshold, then the USB controller is the B device. The USB controller sets the `SESSION` bit in the `USBDEVCTL` register. When RESET signaling is detected on the bus, a RESET interrupt is signaled, which is interpreted as the start of a session.

The USB controller is in Device mode as the B device is the default mode. At the end of the session, the A device turns off the power to VBUS. When VBUS drops below the Session Valid threshold, the USB controller detects this drop and clears the `SESSION` bit to indicate that the session has ended, causing a disconnect interrupt to be signaled. If data line and VBUS pulsing is detected, then the USB controller is the A device. The controller generates a SESSION REQUEST interrupt to indicate that the B device is requesting a session. The `SESSION` bit in the `USBDEVCTL` register must be set to start a session.

17.3.3.3 Host Negotiation

When the USB controller is the A device, ID is Low, and the controller automatically enters Host mode when a session starts. When the USB controller is the B device, ID is High, and the controller automatically enters Device mode when a session starts. However, software can request that the USB controller become the Host by setting the `HOSTREQ` bit in the `USBDEVCTL` register. This bit can be set either at the same time as requesting a Session Start by setting the `SESSION` bit in the `USBDEVCTL` register or at any time after a session has started. When the USB controller next enters SUSPEND mode and if the `HOSTREQ` bit remains set, the controller enters Host mode and begins host negotiation (as specified in the USB On-The-Go supplement) by causing the PHY to disconnect the pull-up resistor on the D+ line, causing the A device to switch to Device mode and connect its own pull-up resistor. When the USB controller detects this, a Connect interrupt is generated and the `RESET` bit in the `USBPOWER` register is set to begin resetting the A device. The

USB controller begins this reset sequence automatically to ensure that RESET is started as required within 1 ms of the A device connecting its pull-up resistor. The main processor should wait at least 20 ms, then clear the RESET bit and enumerate the A device.

When the USB OTG controller B device has finished using the bus, the USB controller goes into SUSPEND mode by setting the SUSPEND bit in the **USBPOWER** register. The A device detects this and either terminates the session or reverts to Host mode. If the A device is USB OTG controller, it generates a Disconnect interrupt.

17.3.4 DMA Operation

The USB peripheral provides an interface connected to the μ DMA controller with separate channels for 3 transmit endpoints and 3 receive endpoints. Software selects which endpoints to service with the μ DMA channels using the **USB DMA Select (USBDMASEL)** register. The μ DMA operation of the USB is enabled through the **USBTXCSRHn** and **USBRXCSRHn** registers, for the TX and RX channels respectively. When μ DMA operation is enabled, the USB asserts a μ DMA request on the enabled receive or transmit channel when the associated FIFO can transfer data. When either FIFO can transfer data, the burst request for that channel is asserted. The μ DMA channel must be configured to operate in Basic mode, and the size of the μ DMA transfer must be restricted to whole multiples of the size of the USB FIFO. Both read and write transfers of the USB FIFOs using μ DMA must be configured in this manner. For example, if the USB endpoint is configured with a FIFO size of 64 bytes, the μ DMA channel can be used to transfer 64 bytes to or from the endpoint FIFO. If the number of bytes to transfer is less than 64, then a programmed I/O method must be used to copy the data to or from the FIFO.

If the DMAMOD bit in the **USBTXCSRHn/USBRXCSRHn** register is clear, an interrupt is generated after every packet is transferred, but the μ DMA continues transferring data. If the DMAMOD bit is set, an interrupt is generated only when the entire μ DMA transfer is complete. The interrupt occurs on the USB interrupt vector. Therefore, if interrupts are used for USB operation and the μ DMA is enabled, the USB interrupt handler must be designed to handle the μ DMA completion interrupt.

Care must be taken when using the μ DMA to unload the receive FIFO as data is read from the receive FIFO in 4 byte chunks regardless of value of the MAXLOAD field in the **USBRXCSRHn** register. The RXRDY bit is cleared as follows.

Table 17-2. Remainder (MAXLOAD/4)

Value	Description
0	MAXLOAD = 64 bytes
1	MAXLOAD = 61 bytes
2	MAXLOAD = 62 bytes
3	MAXLOAD = 63 bytes

Table 17-3. Actual Bytes Read

Value	Description
0	MAXLOAD
1	MAXLOAD+3
2	MAXLOAD+2
3	MAXLOAD+1

Table 17-4. Packet Sizes That Clear RXRDY

Value	Description
0	MAXLOAD, MAXLOAD-1, MAXLOAD-2, MAXLOAD-3
1	MAXLOAD
2	MAXLOAD, MAXLOAD-1
3	MAXLOAD, MAXLOAD-1, MAXLOAD-2

To enable DMA operation for the endpoint receive channel, the `DMAEN` bit of the `USBXCSRHn` register should be set. To enable DMA operation for the endpoint transmit channel, the `DMAEN` bit of the `USBTXCSRHn` register must be set.

See “Micro Direct Memory Access (μ DMA)” on page 559 for more details about programming the μ DMA controller.

17.4 Initialization and Configuration

To use the USB Controller, the peripheral clock must be enabled via the `RCGCUSB` register (see page 328). In addition, the clock to the appropriate GPIO module must be enabled via the `RCGCGPIO` register in the System Control module (see page 319). To find out which GPIO port to enable, refer to Table 22-4 on page 1307. Configure the `PMCn` fields in the `GPIOPCTL` register to assign the USB signals to the appropriate pins (see page 661 and Table 22-5 on page 1314).

The initial configuration in all cases requires that the processor enable the USB controller and USB controller’s physical layer interface (PHY) before setting any registers. The next step is to enable the USB PLL so that the correct clocking is provided to the PHY. To ensure that voltage is not supplied to the bus incorrectly, the external power control signal, `USB0EPEN`, should be negated on start up by configuring the `USB0EPEN` and `USB0PFLT` pins to be controlled by the USB controller and not exhibit their default GPIO behavior.

Note: When used in OTG mode, `USB0VBUS` and `USB0ID` do not require any configuration as they are dedicated pins for the USB controller and directly connect to the USB connector’s VBUS and ID signals. If the USB controller is used as either a dedicated Host or Device, the `DEVMODOTG` and `DEVMOD` bits in the **USB General-Purpose Control and Status (USBGPCS)** register can be used to connect the `USB0VBUS` and `USB0ID` inputs to fixed levels internally, freeing the `PB0` and `PB1` pins for GPIO use. For proper self-powered Device operation, the VBUS value must still be monitored to assure that if the Host removes VBUS, the self-powered Device disables the D+/D- pull-up resistors. This function can be accomplished by connecting a standard GPIO to VBUS.

17.4.1 Pin Configuration

When using the Device controller portion of the USB controller in a system that also provides Host functionality, the power to VBUS must be disabled to allow the external Host controller to supply power. Usually, the `USB0EPEN` signal is used to control the external regulator and should be negated to avoid having two devices driving the `USB0VBUS` power pin on the USB connector.

When the USB controller is acting as a Host, it is in control of two signals that are attached to an external voltage supply that provides power to VBUS. The Host controller uses the `USB0EPEN` signal to enable or disable power to the `USB0VBUS` pin on the USB connector. An input pin, `USB0PFLT`, provides feedback when there has been a power fault on VBUS. The `USB0PFLT` signal can be configured to either automatically negate the `USB0EPEN` signal to disable power, and/or it can generate an interrupt to the interrupt controller to allow software to handle the power fault condition. The polarity and actions related to both `USB0EPEN` and `USB0PFLT` are fully configurable in the USB

controller. The controller also provides interrupts on Device insertion and removal to allow the Host controller code to respond to these external events.

17.4.2 Endpoint Configuration

To start communication in Host or Device mode, the endpoint registers must first be configured. In Host mode, this configuration establishes a connection between an endpoint register and an endpoint on a Device. In Device mode, an endpoint must be configured before enumerating to the Host controller.

In both cases, the endpoint 0 configuration is limited because it is a fixed-function, fixed-FIFO-size endpoint. In Device and Host modes, the endpoint requires little setup but does require a software-based state machine to progress through the setup, data, and status phases of a standard control transaction. In Device mode, the configuration of the remaining endpoints is done once before enumerating and then only changed if an alternate configuration is selected by the Host controller. In Host mode, the endpoints must be configured to operate as control, bulk, interrupt or isochronous mode. Once the type of endpoint is configured, a FIFO area must be assigned to each endpoint. In the case of bulk, control and interrupt endpoints, each has a maximum of 64 bytes per transaction. Isochronous endpoints can have packets with up to 1023 bytes per packet. In either mode, the maximum packet size for the given endpoint must be set prior to sending or receiving data.

Configuring each endpoint's FIFO involves reserving a portion of the overall USB FIFO RAM to each endpoint. The total FIFO RAM available is 2 Kbytes with the first 64 bytes reserved for endpoint 0. The endpoint's FIFO must be at least as large as the maximum packet size. The FIFO can also be configured as a double-buffered FIFO so that interrupts occur at the end of each packet and allow filling the other half of the FIFO.

If operating as a Device, the USB Device controller's soft connect must be enabled when the Device is ready to start communications, indicating to the Host controller that the Device is ready to start the enumeration process. If operating as a Host controller, the Device soft connect must be disabled and power must be provided to VBUS via the `USB0EPEN` signal.

17.5 Register Map

Table 17-5 on page 1074 lists the registers. All addresses given are relative to the USB base address of 0x4005.0000. Note that the USB controller clock must be enabled before the registers can be programmed (see page 328). There must be a delay of 3 system clocks after the USB module clock is enabled before any USB module registers are accessed.

Table 17-5. Universal Serial Bus (USB) Controller Register Map

Offset	Name	Type	Reset	Description	See page
0x000	USBFADDR	R/W	0x00	USB Device Functional Address	1081
0x001	USBPOWER	R/W	0x20	USB Power	1082
0x002	USBTXIS	RO	0x0000	USB Transmit Interrupt Status	1085
0x004	USBRXIS	RO	0x0000	USB Receive Interrupt Status	1087
0x006	USBTXIE	R/W	0xFFFF	USB Transmit Interrupt Enable	1088
0x008	USBRXIE	R/W	0xFFFE	USB Receive Interrupt Enable	1090
0x00A	USBIS	RO	0x00	USB General Interrupt Status	1091

Table 17-5. Universal Serial Bus (USB) Controller Register Map (continued)

Offset	Name	Type	Reset	Description	See page
0x00B	USBIE	R/W	0x06	USB Interrupt Enable	1094
0x00C	USBFRAME	RO	0x0000	USB Frame Value	1097
0x00E	USBEPIDX	R/W	0x00	USB Endpoint Index	1098
0x00F	USBTEST	R/W	0x00	USB Test Mode	1099
0x020	USBFIFO0	R/W	0x0000.0000	USB FIFO Endpoint 0	1101
0x024	USBFIFO1	R/W	0x0000.0000	USB FIFO Endpoint 1	1101
0x028	USBFIFO2	R/W	0x0000.0000	USB FIFO Endpoint 2	1101
0x02C	USBFIFO3	R/W	0x0000.0000	USB FIFO Endpoint 3	1101
0x030	USBFIFO4	R/W	0x0000.0000	USB FIFO Endpoint 4	1101
0x034	USBFIFO5	R/W	0x0000.0000	USB FIFO Endpoint 5	1101
0x038	USBFIFO6	R/W	0x0000.0000	USB FIFO Endpoint 6	1101
0x03C	USBFIFO7	R/W	0x0000.0000	USB FIFO Endpoint 7	1101
0x060	USBDEVCTL	R/W	0x80	USB Device Control	1102
0x062	USBTXFIFOSZ	R/W	0x00	USB Transmit Dynamic FIFO Sizing	1104
0x063	USBRXFIFOSZ	R/W	0x00	USB Receive Dynamic FIFO Sizing	1104
0x064	USBTXFIFOADD	R/W	0x0000	USB Transmit FIFO Start Address	1105
0x066	USBRXFIFOADD	R/W	0x0000	USB Receive FIFO Start Address	1105
0x07A	USBCONTIM	R/W	0x5C	USB Connect Timing	1106
0x07B	USBVPLEN	R/W	0x3C	USB OTG VBUS Pulse Timing	1107
0x07D	USBFSEOF	R/W	0x77	USB Full-Speed Last Transaction to End of Frame Timing	1108
0x07E	USBLSEOF	R/W	0x72	USB Low-Speed Last Transaction to End of Frame Timing	1109
0x080	USBTXFUNCADDR0	R/W	0x00	USB Transmit Functional Address Endpoint 0	1110
0x082	USBTXHUBADDR0	R/W	0x00	USB Transmit Hub Address Endpoint 0	1111
0x083	USBTXHUBPORT0	R/W	0x00	USB Transmit Hub Port Endpoint 0	1112
0x088	USBTXFUNCADDR1	R/W	0x00	USB Transmit Functional Address Endpoint 1	1110
0x08A	USBTXHUBADDR1	R/W	0x00	USB Transmit Hub Address Endpoint 1	1111
0x08B	USBTXHUBPORT1	R/W	0x00	USB Transmit Hub Port Endpoint 1	1112
0x08C	USBRXFUNCADDR1	R/W	0x00	USB Receive Functional Address Endpoint 1	1113
0x08E	USBRXHUBADDR1	R/W	0x00	USB Receive Hub Address Endpoint 1	1114
0x08F	USBRXHUBPORT1	R/W	0x00	USB Receive Hub Port Endpoint 1	1115
0x090	USBTXFUNCADDR2	R/W	0x00	USB Transmit Functional Address Endpoint 2	1110

Table 17-5. Universal Serial Bus (USB) Controller Register Map (continued)

Offset	Name	Type	Reset	Description	See page
0x092	USBTXHUBADDR2	R/W	0x00	USB Transmit Hub Address Endpoint 2	1111
0x093	USBTXHUBPORT2	R/W	0x00	USB Transmit Hub Port Endpoint 2	1112
0x094	USBRXFUNCADDR2	R/W	0x00	USB Receive Functional Address Endpoint 2	1113
0x096	USBRXHUBADDR2	R/W	0x00	USB Receive Hub Address Endpoint 2	1114
0x097	USBRXHUBPORT2	R/W	0x00	USB Receive Hub Port Endpoint 2	1115
0x098	USBTXFUNCADDR3	R/W	0x00	USB Transmit Functional Address Endpoint 3	1110
0x09A	USBTXHUBADDR3	R/W	0x00	USB Transmit Hub Address Endpoint 3	1111
0x09B	USBTXHUBPORT3	R/W	0x00	USB Transmit Hub Port Endpoint 3	1112
0x09C	USBRXFUNCADDR3	R/W	0x00	USB Receive Functional Address Endpoint 3	1113
0x09E	USBRXHUBADDR3	R/W	0x00	USB Receive Hub Address Endpoint 3	1114
0x09F	USBRXHUBPORT3	R/W	0x00	USB Receive Hub Port Endpoint 3	1115
0x0A0	USBTXFUNCADDR4	R/W	0x00	USB Transmit Functional Address Endpoint 4	1110
0x0A2	USBTXHUBADDR4	R/W	0x00	USB Transmit Hub Address Endpoint 4	1111
0x0A3	USBTXHUBPORT4	R/W	0x00	USB Transmit Hub Port Endpoint 4	1112
0x0A4	USBRXFUNCADDR4	R/W	0x00	USB Receive Functional Address Endpoint 4	1113
0x0A6	USBRXHUBADDR4	R/W	0x00	USB Receive Hub Address Endpoint 4	1114
0x0A7	USBRXHUBPORT4	R/W	0x00	USB Receive Hub Port Endpoint 4	1115
0x0A8	USBTXFUNCADDR5	R/W	0x00	USB Transmit Functional Address Endpoint 5	1110
0x0AA	USBTXHUBADDR5	R/W	0x00	USB Transmit Hub Address Endpoint 5	1111
0x0AB	USBTXHUBPORT5	R/W	0x00	USB Transmit Hub Port Endpoint 5	1112
0x0AC	USBRXFUNCADDR5	R/W	0x00	USB Receive Functional Address Endpoint 5	1113
0x0AE	USBRXHUBADDR5	R/W	0x00	USB Receive Hub Address Endpoint 5	1114
0x0AF	USBRXHUBPORT5	R/W	0x00	USB Receive Hub Port Endpoint 5	1115
0x0B0	USBTXFUNCADDR6	R/W	0x00	USB Transmit Functional Address Endpoint 6	1110
0x0B2	USBTXHUBADDR6	R/W	0x00	USB Transmit Hub Address Endpoint 6	1111
0x0B3	USBTXHUBPORT6	R/W	0x00	USB Transmit Hub Port Endpoint 6	1112
0x0B4	USBRXFUNCADDR6	R/W	0x00	USB Receive Functional Address Endpoint 6	1113
0x0B6	USBRXHUBADDR6	R/W	0x00	USB Receive Hub Address Endpoint 6	1114
0x0B7	USBRXHUBPORT6	R/W	0x00	USB Receive Hub Port Endpoint 6	1115
0x0B8	USBTXFUNCADDR7	R/W	0x00	USB Transmit Functional Address Endpoint 7	1110
0x0BA	USBTXHUBADDR7	R/W	0x00	USB Transmit Hub Address Endpoint 7	1111
0x0BB	USBTXHUBPORT7	R/W	0x00	USB Transmit Hub Port Endpoint 7	1112

Table 17-5. Universal Serial Bus (USB) Controller Register Map (continued)

Offset	Name	Type	Reset	Description	See page
0x0BC	USBRXFUNCADDR7	R/W	0x00	USB Receive Functional Address Endpoint 7	1113
0x0BE	USBRXHUBADDR7	R/W	0x00	USB Receive Hub Address Endpoint 7	1114
0x0BF	USBRXHUBPORT7	R/W	0x00	USB Receive Hub Port Endpoint 7	1115
0x102	USBCSRL0	W1C	0x00	USB Control and Status Endpoint 0 Low	1117
0x103	USBCSRH0	W1C	0x00	USB Control and Status Endpoint 0 High	1121
0x108	USBCOUNT0	RO	0x00	USB Receive Byte Count Endpoint 0	1123
0x10A	USBTTYPE0	R/W	0x00	USB Type Endpoint 0	1124
0x10B	USBNAKLMT	R/W	0x00	USB NAK Limit	1125
0x110	USBTXMAXP1	R/W	0x0000	USB Maximum Transmit Data Endpoint 1	1116
0x112	USBTXCSRL1	R/W	0x00	USB Transmit Control and Status Endpoint 1 Low	1126
0x113	USBTXCSRH1	R/W	0x00	USB Transmit Control and Status Endpoint 1 High	1130
0x114	USBRXMAXP1	R/W	0x0000	USB Maximum Receive Data Endpoint 1	1134
0x116	USBRXCSRL1	R/W	0x00	USB Receive Control and Status Endpoint 1 Low	1135
0x117	USBRXCSRH1	R/W	0x00	USB Receive Control and Status Endpoint 1 High	1140
0x118	USBRXCOUNT1	RO	0x0000	USB Receive Byte Count Endpoint 1	1144
0x11A	USBTXTYPE1	R/W	0x00	USB Host Transmit Configure Type Endpoint 1	1145
0x11B	USBTXINTERVAL1	R/W	0x00	USB Host Transmit Interval Endpoint 1	1147
0x11C	USBRXTYPE1	R/W	0x00	USB Host Configure Receive Type Endpoint 1	1148
0x11D	USBRXINTERVAL1	R/W	0x00	USB Host Receive Polling Interval Endpoint 1	1150
0x120	USBTXMAXP2	R/W	0x0000	USB Maximum Transmit Data Endpoint 2	1116
0x122	USBTXCSRL2	R/W	0x00	USB Transmit Control and Status Endpoint 2 Low	1126
0x123	USBTXCSRH2	R/W	0x00	USB Transmit Control and Status Endpoint 2 High	1130
0x124	USBRXMAXP2	R/W	0x0000	USB Maximum Receive Data Endpoint 2	1134
0x126	USBRXCSRL2	R/W	0x00	USB Receive Control and Status Endpoint 2 Low	1135
0x127	USBRXCSRH2	R/W	0x00	USB Receive Control and Status Endpoint 2 High	1140
0x128	USBRXCOUNT2	RO	0x0000	USB Receive Byte Count Endpoint 2	1144
0x12A	USBTXTYPE2	R/W	0x00	USB Host Transmit Configure Type Endpoint 2	1145
0x12B	USBTXINTERVAL2	R/W	0x00	USB Host Transmit Interval Endpoint 2	1147
0x12C	USBRXTYPE2	R/W	0x00	USB Host Configure Receive Type Endpoint 2	1148
0x12D	USBRXINTERVAL2	R/W	0x00	USB Host Receive Polling Interval Endpoint 2	1150
0x130	USBTXMAXP3	R/W	0x0000	USB Maximum Transmit Data Endpoint 3	1116
0x132	USBTXCSRL3	R/W	0x00	USB Transmit Control and Status Endpoint 3 Low	1126

Table 17-5. Universal Serial Bus (USB) Controller Register Map (continued)

Offset	Name	Type	Reset	Description	See page
0x133	USBTXCSRH3	R/W	0x00	USB Transmit Control and Status Endpoint 3 High	1130
0x134	USBRXMAXP3	R/W	0x0000	USB Maximum Receive Data Endpoint 3	1134
0x136	USBRXCSSL3	R/W	0x00	USB Receive Control and Status Endpoint 3 Low	1135
0x137	USBRXCSRH3	R/W	0x00	USB Receive Control and Status Endpoint 3 High	1140
0x138	USBRXCOUNT3	RO	0x0000	USB Receive Byte Count Endpoint 3	1144
0x13A	USBTXTYPE3	R/W	0x00	USB Host Transmit Configure Type Endpoint 3	1145
0x13B	USBTXINTERVAL3	R/W	0x00	USB Host Transmit Interval Endpoint 3	1147
0x13C	USBRXTYPE3	R/W	0x00	USB Host Configure Receive Type Endpoint 3	1148
0x13D	USBRXINTERVAL3	R/W	0x00	USB Host Receive Polling Interval Endpoint 3	1150
0x140	USBTXMAXP4	R/W	0x0000	USB Maximum Transmit Data Endpoint 4	1116
0x142	USBTXCSSL4	R/W	0x00	USB Transmit Control and Status Endpoint 4 Low	1126
0x143	USBTXCSRH4	R/W	0x00	USB Transmit Control and Status Endpoint 4 High	1130
0x144	USBRXMAXP4	R/W	0x0000	USB Maximum Receive Data Endpoint 4	1134
0x146	USBRXCSSL4	R/W	0x00	USB Receive Control and Status Endpoint 4 Low	1135
0x147	USBRXCSRH4	R/W	0x00	USB Receive Control and Status Endpoint 4 High	1140
0x148	USBRXCOUNT4	RO	0x0000	USB Receive Byte Count Endpoint 4	1144
0x14A	USBTXTYPE4	R/W	0x00	USB Host Transmit Configure Type Endpoint 4	1145
0x14B	USBTXINTERVAL4	R/W	0x00	USB Host Transmit Interval Endpoint 4	1147
0x14C	USBRXTYPE4	R/W	0x00	USB Host Configure Receive Type Endpoint 4	1148
0x14D	USBRXINTERVAL4	R/W	0x00	USB Host Receive Polling Interval Endpoint 4	1150
0x150	USBTXMAXP5	R/W	0x0000	USB Maximum Transmit Data Endpoint 5	1116
0x152	USBTXCSSL5	R/W	0x00	USB Transmit Control and Status Endpoint 5 Low	1126
0x153	USBTXCSRH5	R/W	0x00	USB Transmit Control and Status Endpoint 5 High	1130
0x154	USBRXMAXP5	R/W	0x0000	USB Maximum Receive Data Endpoint 5	1134
0x156	USBRXCSSL5	R/W	0x00	USB Receive Control and Status Endpoint 5 Low	1135
0x157	USBRXCSRH5	R/W	0x00	USB Receive Control and Status Endpoint 5 High	1140
0x158	USBRXCOUNT5	RO	0x0000	USB Receive Byte Count Endpoint 5	1144
0x15A	USBTXTYPE5	R/W	0x00	USB Host Transmit Configure Type Endpoint 5	1145
0x15B	USBTXINTERVAL5	R/W	0x00	USB Host Transmit Interval Endpoint 5	1147
0x15C	USBRXTYPE5	R/W	0x00	USB Host Configure Receive Type Endpoint 5	1148
0x15D	USBRXINTERVAL5	R/W	0x00	USB Host Receive Polling Interval Endpoint 5	1150
0x160	USBTXMAXP6	R/W	0x0000	USB Maximum Transmit Data Endpoint 6	1116

Table 17-5. Universal Serial Bus (USB) Controller Register Map (continued)

Offset	Name	Type	Reset	Description	See page
0x162	USBTXCSSL6	R/W	0x00	USB Transmit Control and Status Endpoint 6 Low	1126
0x163	USBTXCSRH6	R/W	0x00	USB Transmit Control and Status Endpoint 6 High	1130
0x164	USBRXMAXP6	R/W	0x0000	USB Maximum Receive Data Endpoint 6	1134
0x166	USBRXCSSL6	R/W	0x00	USB Receive Control and Status Endpoint 6 Low	1135
0x167	USBRXCSRH6	R/W	0x00	USB Receive Control and Status Endpoint 6 High	1140
0x168	USBRXCOUNT6	RO	0x0000	USB Receive Byte Count Endpoint 6	1144
0x16A	USBTXTYPE6	R/W	0x00	USB Host Transmit Configure Type Endpoint 6	1145
0x16B	USBTXINTERVAL6	R/W	0x00	USB Host Transmit Interval Endpoint 6	1147
0x16C	USBRXTYPE6	R/W	0x00	USB Host Configure Receive Type Endpoint 6	1148
0x16D	USBRXINTERVAL6	R/W	0x00	USB Host Receive Polling Interval Endpoint 6	1150
0x170	USBTXMAXP7	R/W	0x0000	USB Maximum Transmit Data Endpoint 7	1116
0x172	USBTXCSSL7	R/W	0x00	USB Transmit Control and Status Endpoint 7 Low	1126
0x173	USBTXCSRH7	R/W	0x00	USB Transmit Control and Status Endpoint 7 High	1130
0x174	USBRXMAXP7	R/W	0x0000	USB Maximum Receive Data Endpoint 7	1134
0x176	USBRXCSSL7	R/W	0x00	USB Receive Control and Status Endpoint 7 Low	1135
0x177	USBRXCSRH7	R/W	0x00	USB Receive Control and Status Endpoint 7 High	1140
0x178	USBRXCOUNT7	RO	0x0000	USB Receive Byte Count Endpoint 7	1144
0x17A	USBTXTYPE7	R/W	0x00	USB Host Transmit Configure Type Endpoint 7	1145
0x17B	USBTXINTERVAL7	R/W	0x00	USB Host Transmit Interval Endpoint 7	1147
0x17C	USBRXTYPE7	R/W	0x00	USB Host Configure Receive Type Endpoint 7	1148
0x17D	USBRXINTERVAL7	R/W	0x00	USB Host Receive Polling Interval Endpoint 7	1150
0x304	USBRQPKTCOUNT1	R/W	0x0000	USB Request Packet Count in Block Transfer Endpoint 1	1151
0x308	USBRQPKTCOUNT2	R/W	0x0000	USB Request Packet Count in Block Transfer Endpoint 2	1151
0x30C	USBRQPKTCOUNT3	R/W	0x0000	USB Request Packet Count in Block Transfer Endpoint 3	1151
0x310	USBRQPKTCOUNT4	R/W	0x0000	USB Request Packet Count in Block Transfer Endpoint 4	1151
0x314	USBRQPKTCOUNT5	R/W	0x0000	USB Request Packet Count in Block Transfer Endpoint 5	1151
0x318	USBRQPKTCOUNT6	R/W	0x0000	USB Request Packet Count in Block Transfer Endpoint 6	1151
0x31C	USBRQPKTCOUNT7	R/W	0x0000	USB Request Packet Count in Block Transfer Endpoint 7	1151

Table 17-5. Universal Serial Bus (USB) Controller Register Map (continued)

Offset	Name	Type	Reset	Description	See page
0x340	USBRXDPKTBUFDIS	R/W	0x0000	USB Receive Double Packet Buffer Disable	1152
0x342	USBTXDPKTBUFDIS	R/W	0x0000	USB Transmit Double Packet Buffer Disable	1153
0x400	USBEPCC	R/W	0x0000.0000	USB External Power Control	1154
0x404	USBEPCCRIS	RO	0x0000.0000	USB External Power Control Raw Interrupt Status	1157
0x408	USBEPCCIM	R/W	0x0000.0000	USB External Power Control Interrupt Mask	1158
0x40C	USBEPCCISC	R/W	0x0000.0000	USB External Power Control Interrupt Status and Clear	1159
0x410	USBDRRIS	RO	0x0000.0000	USB Device RESUME Raw Interrupt Status	1160
0x414	USBDRRIM	R/W	0x0000.0000	USB Device RESUME Interrupt Mask	1161
0x418	USBDRRISC	W1C	0x0000.0000	USB Device RESUME Interrupt Status and Clear	1162
0x41C	USBGPCS	R/W	0x0000.0003	USB General-Purpose Control and Status	1163
0x430	USBVDC	R/W	0x0000.0000	USB VBUS Droop Control	1164
0x434	USBVDCRIS	RO	0x0000.0000	USB VBUS Droop Control Raw Interrupt Status	1165
0x438	USBVDCIM	R/W	0x0000.0000	USB VBUS Droop Control Interrupt Mask	1166
0x43C	USBVDCISC	R/W	0x0000.0000	USB VBUS Droop Control Interrupt Status and Clear	1167
0x444	USBIDVRIS	RO	0x0000.0000	USB ID Valid Detect Raw Interrupt Status	1168
0x448	USBIDVIM	R/W	0x0000.0000	USB ID Valid Detect Interrupt Mask	1169
0x44C	USBIDVISC	R/W1C	0x0000.0000	USB ID Valid Detect Interrupt Status and Clear	1170
0x450	USBDMASEL	R/W	0x0033.2211	USB DMA Select	1171
0xFC0	USBPP	RO	0x0000.10D0	USB Peripheral Properties	1173

17.6 Register Descriptions

The LM4F231H5QR USB controller has On-The-Go (OTG) capabilities as specified in the USB0 bit field in the DC6 register (see page 449).

**OTG B /
Device**

This icon indicates that the register is used in OTG B or Device mode. Some registers are used for both Host and Device mode and may have different bit definitions depending on the mode.

**OTG A /
Host**

This icon indicates that the register is used in OTG A or Host mode. Some registers are used for both Host and Device mode and may have different bit definitions depending on the mode. The USB controller is in OTG B or Device mode upon reset, so the reset values shown for these registers apply to the Device mode definition.

OTG

This icon indicates that the register is used for OTG-specific functions such as ID detection and negotiation. Once OTG negotiation is complete, then the USB controller registers are used according to their Host or Device mode meanings depending on whether the OTG negotiations made the USB controller OTG A (Host) or OTG B (Device).

Register 1: USB Device Functional Address (USBFADDR), offset 0x000**OTG B /
Device**

USBFADDR is an 8-bit register that contains the 7-bit address of the Device part of the transaction.

When the USB controller is being used in Device mode (the `HOST` bit in the **USBDEVCTL** register is clear), this register must be written with the address received through a `SET_ADDRESS` command, which is then used for decoding the function address in subsequent token packets.

Important: See the section called “Setting the Device Address” on page 1065 for special considerations when writing this register.

USB Device Functional Address (USBFADDR)

Base 0x4005.0000

Offset 0x000

Type R/W, reset 0x00

	7	6	5	4	3	2	1	0
	reserved	FUNCADDR						
Type	RO	R/W	R/W	R/W	R/W	R/W	R/W	R/W
Reset	0	0	0	0	0	0	0	0

Bit/Field	Name	Type	Reset	Description
7	reserved	RO	0	Software should not rely on the value of a reserved bit. To provide compatibility with future products, the value of a reserved bit should be preserved across a read-modify-write operation.
6:0	FUNCADDR	R/W	0x00	Function Address Function Address of Device as received through <code>SET_ADDRESS</code> .

Register 2: USB Power (USBPOWER), offset 0x001

OTG A /
Host

USBPOWER is an 8-bit register used for controlling SUSPEND and RESUME signaling and some basic operational aspects of the USB controller.

OTG B /
Device

OTG A / Host Mode

USB Power (USBPOWER)

Base 0x4005.0000
Offset 0x001
Type R/W, reset 0x20

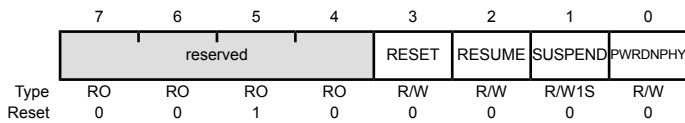

Bit/Field	Name	Type	Reset	Description
7:4	reserved	RO	0x2	Software should not rely on the value of a reserved bit. To provide compatibility with future products, the value of a reserved bit should be preserved across a read-modify-write operation.
3	RESET	R/W	0	RESET Signaling Value Description 1 Enables RESET signaling on the bus. 0 Ends RESET signaling on the bus.
2	RESUME	R/W	0	RESUME Signaling Value Description 1 Enables RESUME signaling when the Device is in SUSPEND mode. 0 Ends RESUME signaling on the bus. This bit must be cleared by software 20 ms after being set.
1	SUSPEND	R/W1S	0	SUSPEND Mode Value Description 1 Enables SUSPEND mode. 0 No effect.

Bit/Field	Name	Type	Reset	Description
0	PWRDNPHY	R/W	0	Power Down PHY
				Value Description
				1 Powers down the internal USB PHY.
				0 No effect.

OTG B / Device Mode

USB Power (USBPOWER)

Base 0x4005.0000
Offset 0x001
Type R/W, reset 0x20

	7	6	5	4	3	2	1	0
Type	R/W	R/W	RO	RO	RO	R/W	RO	R/W
Reset	0	0	1	0	0	0	0	0

Bit/Field	Name	Type	Reset	Description
7	ISOUP	R/W	0	Isochronous Update
				Value Description
				1 The USB controller waits for an SOF token from the time the TXRDY bit is set in the USBTXCSSLn register before sending the packet. If an IN token is received before an SOF token, then a zero-length data packet is sent.
				0 No effect.
				Note: This bit is only valid for isochronous transfers.
6	SOFTCONN	R/W	0	Soft Connect/Disconnect
				Value Description
				1 The USB D+/D- lines are enabled.
				0 The USB D+/D- lines are tri-stated.
5:4	reserved	RO	0x2	Software should not rely on the value of a reserved bit. To provide compatibility with future products, the value of a reserved bit should be preserved across a read-modify-write operation.
3	RESET	RO	0	RESET Signaling
				Value Description
				1 RESET signaling is present on the bus.
				0 RESET signaling is not present on the bus.

Bit/Field	Name	Type	Reset	Description
2	RESUME	R/W	0	RESUME Signaling Value Description 1 Enables RESUME signaling when the Device is in SUSPEND mode. 0 Ends RESUME signaling on the bus. This bit must be cleared by software 10 ms (a maximum of 15 ms) after being set.
1	SUSPEND	RO	0	SUSPEND Mode Value Description 1 The USB controller is in SUSPEND mode. 0 This bit is cleared when software reads the interrupt register or sets the RESUME bit above.
0	PWRDNPHY	R/W	0	Power Down PHY Value Description 1 Powers down the internal USB PHY. 0 No effect.

Register 3: USB Transmit Interrupt Status (USBTXIS), offset 0x002

Important: This register is read-sensitive. See the register description for details.

OTG A /
Host

USBTXIS is a 16-bit read-only register that indicates which interrupts are currently active for endpoint 0 and the transmit endpoints 1–7. The meaning of the EP_n bits in this register is based on the mode of the device. The EP_1 through EP_7 bits always indicate that the USB controller is sending data; however, in Host mode, the bits refer to OUT endpoints; while in Device mode, the bits refer to IN endpoints. The EP_0 bit is special in Host and Device modes and indicates that either a control IN or control OUT endpoint has generated an interrupt.

OTG B /
Device

Note: Bits relating to endpoints that have not been configured always return 0. Note also that all active interrupts are cleared when this register is read.

USB Transmit Interrupt Status (USBTXIS)

Base 0x4005.0000
Offset 0x002
Type RO, reset 0x0000

	15	14	13	12	11	10	9	8	7	6	5	4	3	2	1	0
	reserved								EP7	EP6	EP5	EP4	EP3	EP2	EP1	EP0
Type	RO	RO	RO	RO	RO	RO	RO	RO	RO	RO	RO	RO	RO	RO	RO	RO
Reset	0	0	0	0	0	0	0	0	0	0	0	0	0	0	0	0

Bit/Field	Name	Type	Reset	Description
15:8	reserved	RO	0	Software should not rely on the value of a reserved bit. To provide compatibility with future products, the value of a reserved bit should be preserved across a read-modify-write operation.
7	EP7	RO	0	TX Endpoint 7 Interrupt Value Description 0 No interrupt. 1 The Endpoint 7 transmit interrupt is asserted.
6	EP6	RO	0	TX Endpoint 6 Interrupt Same description as EP7.
5	EP5	RO	0	TX Endpoint 5 Interrupt Same description as EP7.
4	EP4	RO	0	TX Endpoint 4 Interrupt Same description as EP7.
3	EP3	RO	0	TX Endpoint 3 Interrupt Same description as EP7.
2	EP2	RO	0	TX Endpoint 2 Interrupt Same description as EP7.
1	EP1	RO	0	TX Endpoint 1 Interrupt Same description as EP7.

Bit/Field	Name	Type	Reset	Description
0	EP0	RO	0	TX and RX Endpoint 0 Interrupt
				Value Description
				0 No interrupt.
				1 The Endpoint 0 transmit and receive interrupt is asserted.

Register 4: USB Receive Interrupt Status (USBRIX), offset 0x004

Important: This register is read-sensitive. See the register description for details.

OTG A /
Host

USBRIX is a 16-bit read-only register that indicates which of the interrupts for receive endpoints 1–7 are currently active.

Note: Bits relating to endpoints that have not been configured always return 0. Note also that all active interrupts are cleared when this register is read.

OTG B /
Device

USB Receive Interrupt Status (USBRIX)

Base 0x4005.0000
Offset 0x004
Type RO, reset 0x0000

	15	14	13	12	11	10	9	8	7	6	5	4	3	2	1	0
	reserved								EP7	EP6	EP5	EP4	EP3	EP2	EP1	reserved
Type	RO	RO	RO	RO	RO	RO	RO	RO	RO	RO	RO	RO	RO	RO	RO	RO
Reset	0	0	0	0	0	0	0	0	0	0	0	0	0	0	0	0

Bit/Field	Name	Type	Reset	Description
15:8	reserved	RO	0	Software should not rely on the value of a reserved bit. To provide compatibility with future products, the value of a reserved bit should be preserved across a read-modify-write operation.
7	EP7	RO	0	RX Endpoint 7 Interrupt Value Description 0 No interrupt. 1 The Endpoint 7 transmit interrupt is asserted.
6	EP6	RO	0	RX Endpoint 6 Interrupt Same description as EP7.
5	EP5	RO	0	RX Endpoint 5 Interrupt Same description as EP7.
4	EP4	RO	0	RX Endpoint 4 Interrupt Same description as EP7.
3	EP3	RO	0	RX Endpoint 3 Interrupt Same description as EP7.
2	EP2	RO	0	RX Endpoint 2 Interrupt Same description as EP7.
1	EP1	RO	0	RX Endpoint 1 Interrupt Same description as EP7.
0	reserved	RO	0	Software should not rely on the value of a reserved bit. To provide compatibility with future products, the value of a reserved bit should be preserved across a read-modify-write operation.

Register 5: USB Transmit Interrupt Enable (USBTXIE), offset 0x006

OTG A /
Host

USBTXIE is a 16-bit register that provides interrupt enable bits for the interrupts in the **USBTXIS** register. When a bit is set, the USB interrupt is asserted to the interrupt controller when the corresponding interrupt bit in the **USBTXIS** register is set. When a bit is cleared, the interrupt in the **USBTXIS** register is still set but the USB interrupt to the interrupt controller is not asserted. On reset, all interrupts are enabled.

OTG B /
Device

USB Transmit Interrupt Enable (USBTXIE)

Base 0x4005.0000
Offset 0x006

Type R/W, reset 0xFFFF

	15	14	13	12	11	10	9	8	7	6	5	4	3	2	1	0
	reserved								EP7	EP6	EP5	EP4	EP3	EP2	EP1	EP0
Type	RO	RO	RO	RO	RO	RO	RO	RO	R/W	R/W	R/W	R/W	R/W	R/W	R/W	R/W
Reset	0	0	0	0	0	0	0	0	1	1	1	1	1	1	1	1

Bit/Field	Name	Type	Reset	Description
15:8	reserved	RO	0	Software should not rely on the value of a reserved bit. To provide compatibility with future products, the value of a reserved bit should be preserved across a read-modify-write operation.
7	EP7	R/W	1	TX Endpoint 7 Interrupt Enable Value Description 1 An interrupt is sent to the interrupt controller when the EP7 bit in the USBTXIS register is set. 0 The EP7 transmit interrupt is suppressed and not sent to the interrupt controller.
6	EP6	R/W	1	TX Endpoint 6 Interrupt Enable Same description as EP7.
5	EP5	R/W	1	TX Endpoint 5 Interrupt Enable Same description as EP7.
4	EP4	R/W	1	TX Endpoint 4 Interrupt Enable Same description as EP7.
3	EP3	R/W	1	TX Endpoint 3 Interrupt Enable Same description as EP7.
2	EP2	R/W	1	TX Endpoint 2 Interrupt Enable Same description as EP7.
1	EP1	R/W	1	TX Endpoint 1 Interrupt Enable Same description as EP7.

Bit/Field	Name	Type	Reset	Description
0	EP0	R/W	1	TX and RX Endpoint 0 Interrupt Enable
				Value Description
			1	An interrupt is sent to the interrupt controller when the EP0 bit in the USBTXIS register is set.
			0	The EP0 transmit and receive interrupt is suppressed and not sent to the interrupt controller.

Register 6: USB Receive Interrupt Enable (USBRXIE), offset 0x008

OTG A /
Host

USBRXIE is a 16-bit register that provides interrupt enable bits for the interrupts in the **USBRXIS** register. When a bit is set, the USB interrupt is asserted to the interrupt controller when the corresponding interrupt bit in the **USBRXIS** register is set. When a bit is cleared, the interrupt in the **USBRXIS** register is still set but the USB interrupt to the interrupt controller is not asserted. On reset, all interrupts are enabled.

OTG B /
Device

USB Receive Interrupt Enable (USBRXIE)

Base 0x4005.0000
Offset 0x008

Type R/W, reset 0xFFFE

	15	14	13	12	11	10	9	8	7	6	5	4	3	2	1	0
	reserved								EP7	EP6	EP5	EP4	EP3	EP2	EP1	reserved
Type	RO	RO	RO	RO	RO	RO	RO	RO	R/W	R/W	R/W	R/W	R/W	R/W	R/W	RO
Reset	0	0	0	0	0	0	0	0	1	1	1	1	1	1	1	0

Bit/Field	Name	Type	Reset	Description
15:8	reserved	RO	0	Software should not rely on the value of a reserved bit. To provide compatibility with future products, the value of a reserved bit should be preserved across a read-modify-write operation.
7	EP7	R/W	1	RX Endpoint 7 Interrupt Enable Value Description 1 An interrupt is sent to the interrupt controller when the EP7 bit in the USBRXIS register is set. 0 The EP7 receive interrupt is suppressed and not sent to the interrupt controller.
6	EP6	R/W	1	RX Endpoint 6 Interrupt Enable Same description as EP7.
5	EP5	R/W	1	RX Endpoint 5 Interrupt Enable Same description as EP7.
4	EP4	R/W	1	RX Endpoint 4 Interrupt Enable Same description as EP7.
3	EP3	R/W	1	RX Endpoint 3 Interrupt Enable Same description as EP7.
2	EP2	R/W	1	RX Endpoint 2 Interrupt Enable Same description as EP7.
1	EP1	R/W	1	RX Endpoint 1 Interrupt Enable Same description as EP7.
0	reserved	RO	0	Software should not rely on the value of a reserved bit. To provide compatibility with future products, the value of a reserved bit should be preserved across a read-modify-write operation.

Register 7: USB General Interrupt Status (USBIS), offset 0x00A

Important: This register is read-sensitive. See the register description for details.

OTG A /
Host

USBIS is an 8-bit read-only register that indicates which USB interrupts are currently active. All active interrupts are cleared when this register is read.

OTG B /
Device

OTG A / Host Mode

USB General Interrupt Status (USBIS)

Base 0x4005.0000

Offset 0x00A

Type RO, reset 0x00

	7	6	5	4	3	2	1	0
	VBUSERR	SESREQ	DISCON	CONN	SOF	BABBLE	RESUME	reserved
Type	RO	RO	RO	RO	RO	RO	RO	RO
Reset	0	0	0	0	0	0	0	0

Bit/Field	Name	Type	Reset	Description
7	VBUSERR	RO	0	VBUS Error Value Description 1 VBUS has dropped below the VBUS Valid threshold during a session. 0 No interrupt.
6	SESREQ	RO	0	SESSION REQUEST Value Description 1 SESSION REQUEST signaling has been detected. 0 No interrupt.
5	DISCON	RO	0	Session Disconnect Value Description 1 A Device disconnect has been detected. 0 No interrupt.
4	CONN	RO	0	Session Connect Value Description 1 A Device connection has been detected. 0 No interrupt.

Bit/Field	Name	Type	Reset	Description
3	SOF	RO	0	Start of Frame Value Description 1 A new frame has started. 0 No interrupt.
2	BABBLE	RO	0	Babble Detected Value Description 1 Babble has been detected. This interrupt is active only after the first SOF has been sent. 0 No interrupt.
1	RESUME	RO	0	RESUME Signaling Detected Value Description 1 RESUME signaling has been detected on the bus while the USB controller is in SUSPEND mode. 0 No interrupt. This interrupt can only be used if the USB controller's system clock is enabled. If the user disables the clock programming, the USBDRRIS , USBDRIM , and USBDRISC registers should be used.
0	reserved	RO	0	Software should not rely on the value of a reserved bit. To provide compatibility with future products, the value of a reserved bit should be preserved across a read-modify-write operation.

OTG B / Device Mode

USB General Interrupt Status (USBIS)

Base 0x4005.0000
Offset 0x00A
Type RO, reset 0x00

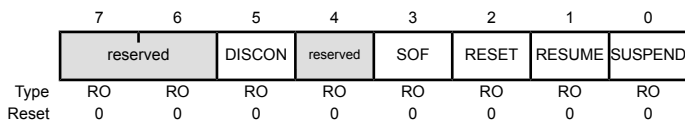

Bit/Field	Name	Type	Reset	Description
7:6	reserved	RO	0x0	Software should not rely on the value of a reserved bit. To provide compatibility with future products, the value of a reserved bit should be preserved across a read-modify-write operation.
5	DISCON	RO	0	Session Disconnect Value Description 1 The device has been disconnected from the host. 0 No interrupt.

Bit/Field	Name	Type	Reset	Description
4	reserved	RO	0	Software should not rely on the value of a reserved bit. To provide compatibility with future products, the value of a reserved bit should be preserved across a read-modify-write operation.
3	SOF	RO	0	Start of Frame Value Description 1 A new frame has started. 0 No interrupt.
2	RESET	RO	0	RESET Signaling Detected Value Description 1 RESET signaling has been detected on the bus. 0 No interrupt.
1	RESUME	RO	0	RESUME Signaling Detected Value Description 1 RESUME signaling has been detected on the bus while the USB controller is in SUSPEND mode. 0 No interrupt. This interrupt can only be used if the USB controller's system clock is enabled. If the user disables the clock programming, the USBDRRIS , USBDRIM , and USBDRISC registers should be used.
0	SUSPEND	RO	0	SUSPEND Signaling Detected Value Description 1 SUSPEND signaling has been detected on the bus. 0 No interrupt.

Register 8: USB Interrupt Enable (USBIE), offset 0x00B

OTG A /
Host

USBIE is an 8-bit register that provides interrupt enable bits for each of the interrupts in **USBIS**. At reset interrupts 1 and 2 are enabled in Device mode.

OTG B /
Device

OTG A / Host Mode

USB Interrupt Enable (USBIE)

Base 0x4005.0000
Offset 0x00B
Type R/W, reset 0x06

	7	6	5	4	3	2	1	0
	VBUSERR	SESREQ	DISCON	CONN	SOF	BABBLE	RESUME	reserved
Type	R/W	R/W	R/W	R/W	R/W	R/W	R/W	RO
Reset	0	0	0	0	0	1	1	0

Bit/Field	Name	Type	Reset	Description
7	VBUSERR	R/W	0	<p>Enable VBUS Error Interrupt</p> <p>Value Description</p> <p>1 An interrupt is sent to the interrupt controller when the VBUSERR bit in the USBIS register is set.</p> <p>0 The VBUSERR interrupt is suppressed and not sent to the interrupt controller.</p>
6	SESREQ	R/W	0	<p>Enable Session Request</p> <p>Value Description</p> <p>1 An interrupt is sent to the interrupt controller when the SESREQ bit in the USBIS register is set.</p> <p>0 The SESREQ interrupt is suppressed and not sent to the interrupt controller.</p>
5	DISCON	R/W	0	<p>Enable Disconnect Interrupt</p> <p>Value Description</p> <p>1 An interrupt is sent to the interrupt controller when the DISCON bit in the USBIS register is set.</p> <p>0 The DISCON interrupt is suppressed and not sent to the interrupt controller.</p>

Bit/Field	Name	Type	Reset	Description
4	CONN	R/W	0	Enable Connect Interrupt Value Description 1 An interrupt is sent to the interrupt controller when the CONN bit in the USBIS register is set. 0 The CONN interrupt is suppressed and not sent to the interrupt controller.
3	SOF	R/W	0	Enable Start-of-Frame Interrupt Value Description 1 An interrupt is sent to the interrupt controller when the SOF bit in the USBIS register is set. 0 The SOF interrupt is suppressed and not sent to the interrupt controller.
2	BABBLE	R/W	1	Enable Babble Interrupt Value Description 1 An interrupt is sent to the interrupt controller when the BABBLE bit in the USBIS register is set. 0 The BABBLE interrupt is suppressed and not sent to the interrupt controller.
1	RESUME	R/W	1	Enable RESUME Interrupt Value Description 1 An interrupt is sent to the interrupt controller when the RESUME bit in the USBIS register is set. 0 The RESUME interrupt is suppressed and not sent to the interrupt controller.
0	reserved	RO	0	Software should not rely on the value of a reserved bit. To provide compatibility with future products, the value of a reserved bit should be preserved across a read-modify-write operation.

OTG B / Device Mode

USB Interrupt Enable (USBIE)

Base 0x4005.0000

Offset 0x00B

Type R/W, reset 0x06

	7	6	5	4	3	2	1	0
Type	RO	RO	R/W	RO	R/W	R/W	R/W	R/W
Reset	0	0	0	0	0	1	1	0

Bit/Field	Name	Type	Reset	Description
7:6	reserved	RO	0x0	Software should not rely on the value of a reserved bit. To provide compatibility with future products, the value of a reserved bit should be preserved across a read-modify-write operation.
5	DISCON	R/W	0	<p>Enable Disconnect Interrupt</p> <p>Value Description</p> <p>1 An interrupt is sent to the interrupt controller when the DISCON bit in the USBIS register is set.</p> <p>0 The DISCON interrupt is suppressed and not sent to the interrupt controller.</p>
4	reserved	RO	0	Software should not rely on the value of a reserved bit. To provide compatibility with future products, the value of a reserved bit should be preserved across a read-modify-write operation.
3	SOF	R/W	0	<p>Enable Start-of-Frame Interrupt</p> <p>Value Description</p> <p>1 An interrupt is sent to the interrupt controller when the SOF bit in the USBIS register is set.</p> <p>0 The SOF interrupt is suppressed and not sent to the interrupt controller.</p>
2	RESET	R/W	1	<p>Enable RESET Interrupt</p> <p>Value Description</p> <p>1 An interrupt is sent to the interrupt controller when the RESET bit in the USBIS register is set.</p> <p>0 The RESET interrupt is suppressed and not sent to the interrupt controller.</p>
1	RESUME	R/W	1	<p>Enable RESUME Interrupt</p> <p>Value Description</p> <p>1 An interrupt is sent to the interrupt controller when the RESUME bit in the USBIS register is set.</p> <p>0 The RESUME interrupt is suppressed and not sent to the interrupt controller.</p>
0	SUSPEND	R/W	0	<p>Enable SUSPEND Interrupt</p> <p>Value Description</p> <p>1 An interrupt is sent to the interrupt controller when the SUSPEND bit in the USBIS register is set.</p> <p>0 The SUSPEND interrupt is suppressed and not sent to the interrupt controller.</p>

Register 9: USB Frame Value (USBFRAME), offset 0x00C

OTG A /
Host

USBFRAME is a 16-bit read-only register that holds the last received frame number.

USB Frame Value (USBFRAME)

Base 0x4005.0000

Offset 0x00C

Type RO, reset 0x0000

OTG B /
Device

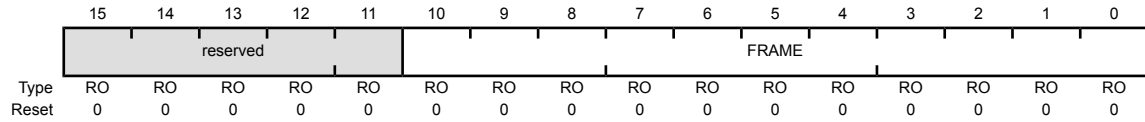

Bit/Field	Name	Type	Reset	Description
15:11	reserved	RO	0x0	Software should not rely on the value of a reserved bit. To provide compatibility with future products, the value of a reserved bit should be preserved across a read-modify-write operation.
10:0	FRAME	RO	0x000	Frame Number

Register 10: USB Endpoint Index (USBEPIDX), offset 0x00E

OTG A /
Host

Each endpoint's buffer can be accessed by configuring a FIFO size and starting address. The **USBEPIDX** 8-bit register is used with the **USBTXFIFOSZ**, **USBRXFIFOSZ**, **USBTXFIFOADD**, and **USBRXFIFOADD** registers.

OTG B /
Device

USB Endpoint Index (USBEPIDX)

Base 0x4005.0000
Offset 0x00E
Type R/W, reset 0x00

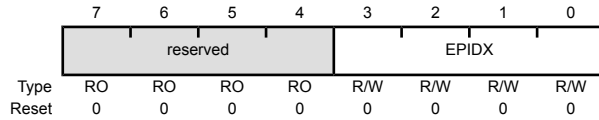

Bit/Field	Name	Type	Reset	Description
7:4	reserved	RO	0x0	Software should not rely on the value of a reserved bit. To provide compatibility with future products, the value of a reserved bit should be preserved across a read-modify-write operation.
3:0	EPIDX	R/W	0x0	Endpoint Index This bit field configures which endpoint is accessed when reading or writing to one of the USB controller's indexed registers. A value of 0x0 corresponds to Endpoint 0 and a value of 0x7 corresponds to Endpoint 7.

Register 11: USB Test Mode (USBTEST), offset 0x00F

OTG A /
Host

USBTEST is an 8-bit register that is primarily used to put the USB controller into one of the four test modes for operation described in the *USB 2.0 Specification*, in response to a SET FEATURE: USBTESTMODE command. This register is not used in normal operation.

OTG B /
Device

Note: Only one of these bits should be set at any time.

OTG A / Host Mode

USB Test Mode (USBTEST)

Base 0x4005.0000
Offset 0x00F
Type R/W, reset 0x00

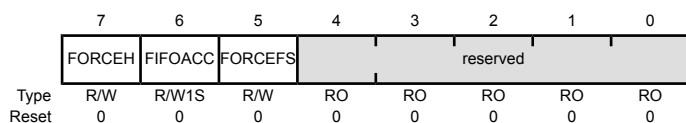

Bit/Field	Name	Type	Reset	Description
7	FORCEH	R/W	0	Force Host Mode

Value Description

1 Forces the USB controller to enter Host mode when the `SESSION` bit is set, regardless of whether the USB controller is connected to any peripheral. The state of the `USB0DP` and `USB0DM` signals is ignored. The USB controller then remains in Host mode until the `SESSION` bit is cleared, even if a Device is disconnected. If the `FORCEH` bit remains set, the USB controller re-enters Host mode the next time the `SESSION` bit is set.

0 No effect.

While in this mode, status of the bus connection may be read using the `DEV` bit of the `USBDEVCTL` register. The operating speed is determined from the `FORCEFS` bit.

6	FIFOACC	R/W1S	0	FIFO Access
---	---------	-------	---	-------------

Value Description

1 Transfers the packet in the endpoint 0 transmit FIFO to the endpoint 0 receive FIFO.

0 No effect.

This bit is cleared automatically.

5	FORCEFS	R/W	0	Force Full-Speed Mode
---	---------	-----	---	-----------------------

Value Description

1 Forces the USB controller into Full-Speed mode upon receiving a USB RESET.

0 The USB controller operates at Low Speed.

Bit/Field	Name	Type	Reset	Description
4:0	reserved	RO	0x0	Software should not rely on the value of a reserved bit. To provide compatibility with future products, the value of a reserved bit should be preserved across a read-modify-write operation.

OTG B / Device Mode

USB Test Mode (USBTEST)

Base 0x4005.0000
 Offset 0x00F
 Type R/W, reset 0x00

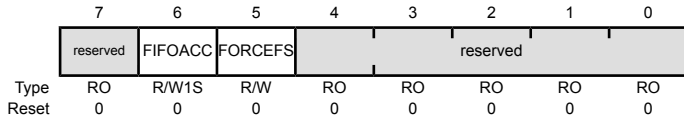

Bit/Field	Name	Type	Reset	Description
7	reserved	RO	0	Software should not rely on the value of a reserved bit. To provide compatibility with future products, the value of a reserved bit should be preserved across a read-modify-write operation.
6	FIFOACC	R/W1S	0	FIFO Access Value Description 1 Transfers the packet in the endpoint 0 transmit FIFO to the endpoint 0 receive FIFO. 0 No effect. This bit is cleared automatically.
5	FORCEFS	R/W	0	Force Full-Speed Mode Value Description 1 Forces the USB controller into Full-Speed mode upon receiving a USB RESET. 0 The USB controller operates at Low Speed.
4:0	reserved	RO	0x0	Software should not rely on the value of a reserved bit. To provide compatibility with future products, the value of a reserved bit should be preserved across a read-modify-write operation.

Register 12: USB FIFO Endpoint 0 (USBFIFO0), offset 0x020

Register 13: USB FIFO Endpoint 1 (USBFIFO1), offset 0x024

Register 14: USB FIFO Endpoint 2 (USBFIFO2), offset 0x028

Register 15: USB FIFO Endpoint 3 (USBFIFO3), offset 0x02C

Register 16: USB FIFO Endpoint 4 (USBFIFO4), offset 0x030

Register 17: USB FIFO Endpoint 5 (USBFIFO5), offset 0x034

Register 18: USB FIFO Endpoint 6 (USBFIFO6), offset 0x038

Register 19: USB FIFO Endpoint 7 (USBFIFO7), offset 0x03C

Important: This register is read-sensitive. See the register description for details.

**OTG A /
Host**

These 32-bit registers provide an address for CPU access to the FIFOs for each endpoint. Writing to these addresses loads data into the Transmit FIFO for the corresponding endpoint. Reading from these addresses unloads data from the Receive FIFO for the corresponding endpoint.

**OTG B /
Device**

Transfers to and from FIFOs may be 8-bit, 16-bit or 32-bit as required, and any combination of accesses is allowed provided the data accessed is contiguous. All transfers associated with one packet must be of the same width so that the data is consistently byte-, halfword- or word-aligned. However, the last transfer may contain fewer bytes than the previous transfers in order to complete an odd-byte or odd-word transfer.

Depending on the size of the FIFO and the expected maximum packet size, the FIFOs support either single-packet or double-packet buffering (see the section called “Single-Packet Buffering” on page 1063). Burst writing of multiple packets is not supported as flags must be set after each packet is written.

Following a STALL response or a transmit error on endpoint 1–7, the associated FIFO is completely flushed.

USB FIFO Endpoint n (USBFIFOn)

Base 0x4005.0000
Offset 0x020
Type R/W, reset 0x0000.0000

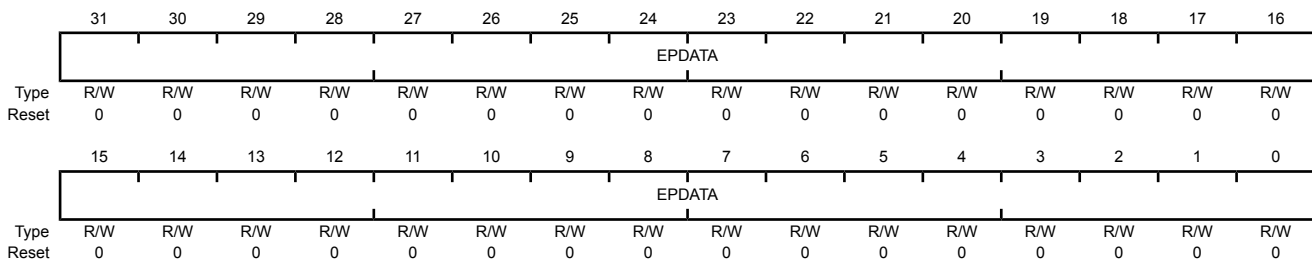

Bit/Field	Name	Type	Reset	Description
31:0	EPDATA	R/W	0x0000.0000	Endpoint Data Writing to this register loads the data into the Transmit FIFO and reading unloads data from the Receive FIFO.

Register 20: USB Device Control (USBDEVCTL), offset 0x060

OTG A /
Host

USBDEVCTL is an 8-bit register used for controlling and monitoring the USB VBUS line. If the PHY is suspended, no PHY clock is received and the VBUS is not sampled. In addition, in Host mode, **USBDEVCTL** provides the status information for the current operating mode (Host or Device) of the USB controller. If the USB controller is in Host mode, this register also indicates if a full- or low-speed Device has been connected.

USB Device Control (USBDEVCTL)

Base 0x4005.0000
Offset 0x060
Type R/W, reset 0x80

	7	6	5	4	3	2	1	0
	DEV	FSDEV	LSDEV	VBUS		HOST	HOSTREQ	SESSION
Type	RO	RO	RO	RO	RO	RO	R/W	R/W
Reset	1	0	0	0	0	0	0	0

Bit/Field	Name	Type	Reset	Description
7	DEV	RO	1	Device Mode Value Description 0 The USB controller is operating on the OTG A side of the cable. 1 The USB controller is operating on the OTG B side of the cable. Note: This value is only valid while a session is in progress.
6	FSDEV	RO	0	Full-Speed Device Detected Value Description 0 A full-speed Device has not been detected on the port. 1 A full-speed Device has been detected on the port.
5	LSDEV	RO	0	Low-Speed Device Detected Value Description 0 A low-speed Device has not been detected on the port. 1 A low-speed Device has been detected on the port.
4:3	VBUS	RO	0x0	VBUS Level Value Description 0x0 Below SessionEnd VBUS is detected as under 0.5 V. 0x1 Above SessionEnd, below AValid VBUS is detected as above 0.5 V and under 1.5 V. 0x2 Above AValid, below VBUSValid VBUS is detected as above 1.5 V and below 4.75 V. 0x3 Above VBUSValid VBUS is detected as above 4.75 V.

Bit/Field	Name	Type	Reset	Description
2	HOST	RO	0	<p>Host Mode</p> <p>Value Description</p> <p>0 The USB controller is acting as a Device.</p> <p>1 The USB controller is acting as a Host.</p> <p>Note: This value is only valid while a session is in progress.</p>
1	HOSTREQ	R/W	0	<p>Host Request</p> <p>Value Description</p> <p>0 No effect.</p> <p>1 Initiates the Host Negotiation when SUSPEND mode is entered.</p> <p>This bit is cleared when Host Negotiation is completed.</p>
0	SESSION	R/W	0	<p>Session Start/End</p> <p><i>When operating as an OTG A device:</i></p> <p>Value Description</p> <p>0 When cleared by software, this bit ends a session.</p> <p>1 When set by software, this bit starts a session.</p> <p><i>When operating as an OTG B device:</i></p> <p>Value Description</p> <p>0 The USB controller has ended a session. When the USB controller is in SUSPEND mode, this bit may be cleared by software to perform a software disconnect.</p> <p>1 The USB controller has started a session. When set by software, the Session Request Protocol is initiated.</p> <p>Note: Clearing this bit when the USB controller is not suspended results in undefined behavior.</p>

Register 21: USB Transmit Dynamic FIFO Sizing (USBTXFIFOSZ), offset 0x062

Register 22: USB Receive Dynamic FIFO Sizing (USBRXFIFOSZ), offset 0x063

OTG A /
Host

These 8-bit registers allow the selected TX/RX endpoint FIFOs to be dynamically sized. **USBEPIDX** is used to configure each transmit endpoint's FIFO size.

OTG B /
Device

USB Dynamic FIFO Sizing (USBnXFIFOSZ)

Base 0x4005.0000
Offset 0x062
Type R/W, reset 0x00

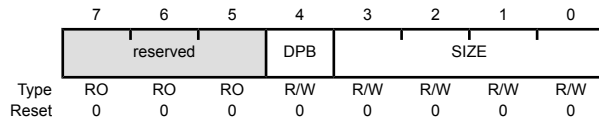

Bit/Field	Name	Type	Reset	Description
7:5	reserved	RO	0x0	Software should not rely on the value of a reserved bit. To provide compatibility with future products, the value of a reserved bit should be preserved across a read-modify-write operation.
4	DPB	R/W	0	Double Packet Buffer Support Value Description 0 Only single-packet buffering is supported. 1 Double-packet buffering is supported.
3:0	SIZE	R/W	0x0	Max Packet Size Maximum packet size to be allowed. If DPB = 0, the FIFO also is this size; if DPB = 1, the FIFO is twice this size. Value Packet Size (Bytes) 0x0 8 0x1 16 0x2 32 0x3 64 0x4 128 0x5 256 0x6 512 0x7 1024 0x8 2048 0x9-0xF Reserved

Register 23: USB Transmit FIFO Start Address (USBTXFIFOADD), offset 0x064**Register 24: USB Receive FIFO Start Address (USBRXFIFOADD), offset 0x066**

OTG A /
Host

USBTXFIFOADD and **USBRXFIFOADD** are 16-bit registers that control the start address of the selected transmit and receive endpoint FIFOs.

USB Transmit FIFO Start Address (USBnXFIFOADD)

OTG B /
Device

Base 0x4005.0000
Offset 0x064
Type R/W, reset 0x0000

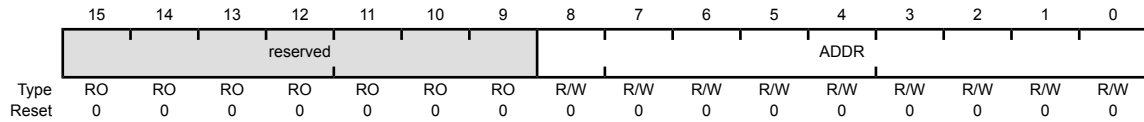

Bit/Field	Name	Type	Reset	Description
15:9	reserved	RO	0x00	Software should not rely on the value of a reserved bit. To provide compatibility with future products, the value of a reserved bit should be preserved across a read-modify-write operation.
8:0	ADDR	R/W	0x00	Transmit/Receive Start Address Start address of the endpoint FIFO.
	Value	Start Address		
	0x0	0		
	0x1	8		
	0x2	16		
	0x3	24		
	0x4	32		
	0x5	40		
	0x6	48		
	0x7	56		
	0x8	64		
		
	0x1FF	4095		

Register 25: USB Connect Timing (USBCONTIM), offset 0x07A

OTG A /
Host

This 8-bit configuration register specifies connection and negotiation delays.

USB Connect Timing (USBCONTIM)

Base 0x4005.0000

Offset 0x07A

Type R/W, reset 0x5C

OTG B /
Device

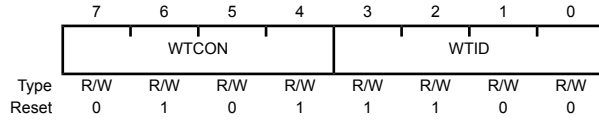

Bit/Field	Name	Type	Reset	Description
7:4	WTCON	R/W	0x5	Connect Wait This field configures the wait required to allow for the user's connect/disconnect filter, in units of 533.3 ns. The default corresponds to 2.667 μ s.
3:0	WTID	R/W	0xC	Wait ID This field configures the delay required from the enable of the ID detection to when the ID value is valid, in units of 4.369 ms. The default corresponds to 52.43 ms.

Register 26: USB OTG VBUS Pulse Timing (USBVPLEN), offset 0x07B**OTG**

This 8-bit configuration register specifies the duration of the VBUS pulsing charge.

USB OTG VBUS Pulse Timing (USBVPLEN)

Base 0x4005.0000
 Offset 0x07B
 Type R/W, reset 0x3C

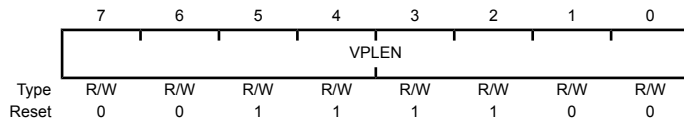

Bit/Field	Name	Type	Reset	Description
7:0	VPLEN	R/W	0x3C	VBUS Pulse Length This field configures the duration of the VBUS pulsing charge in units of 546.1 μ s. The default corresponds to 32.77 ms.

Register 27: USB Full-Speed Last Transaction to End of Frame Timing (USBFSEOF), offset 0x07D

OTG A /
Host

This 8-bit configuration register specifies the minimum time gap allowed between the start of the last transaction and the EOF for full-speed transactions.

OTG B /
Device

USB Full-Speed Last Transaction to End of Frame Timing (USBFSEOF)

Base 0x4005.0000
Offset 0x07D
Type R/W, reset 0x77

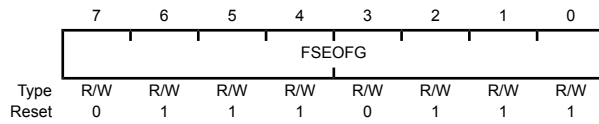

Bit/Field	Name	Type	Reset	Description
7:0	FSEOFG	R/W	0x77	<p>Full-Speed End-of-Frame Gap</p> <p>This field is used during full-speed transactions to configure the gap between the last transaction and the End-of-Frame (EOF), in units of 533.3 ns. The default corresponds to 63.46 μs.</p>

Register 28: USB Low-Speed Last Transaction to End of Frame Timing (USBLSEOF), offset 0x07E

OTG A /
Host

This 8-bit configuration register specifies the minimum time gap that is to be allowed between the start of the last transaction and the EOF for low-speed transactions.

OTG B /
Device

USB Low-Speed Last Transaction to End of Frame Timing (USBLSEOF)

Base 0x4005.0000
Offset 0x07E
Type R/W, reset 0x72

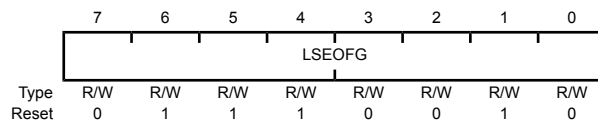

Bit/Field	Name	Type	Reset	Description
7:0	LSEOFG	R/W	0x72	<p>Low-Speed End-of-Frame Gap</p> <p>This field is used during low-speed transactions to set the gap between the last transaction and the End-of-Frame (EOF), in units of 1.067 μs. The default corresponds to 121.6 μs.</p>

Register 29: USB Transmit Functional Address Endpoint 0 (USBTXFUNCADDR0), offset 0x080

Register 30: USB Transmit Functional Address Endpoint 1 (USBTXFUNCADDR1), offset 0x088

Register 31: USB Transmit Functional Address Endpoint 2 (USBTXFUNCADDR2), offset 0x090

Register 32: USB Transmit Functional Address Endpoint 3 (USBTXFUNCADDR3), offset 0x098

Register 33: USB Transmit Functional Address Endpoint 4 (USBTXFUNCADDR4), offset 0x0A0

Register 34: USB Transmit Functional Address Endpoint 5 (USBTXFUNCADDR5), offset 0x0A8

Register 35: USB Transmit Functional Address Endpoint 6 (USBTXFUNCADDR6), offset 0x0B0

Register 36: USB Transmit Functional Address Endpoint 7 (USBTXFUNCADDR7), offset 0x0B8

OTG A /
Host

USBTXFUNCADDRn is an 8-bit read/write register that records the address of the target function to be accessed through the associated endpoint (EPn). USBTXFUNCADDRn must be defined for each transmit endpoint that is used.

Note: USBTXFUNCADDR0 is used for both receive and transmit for endpoint 0.

USB Transmit Functional Address Endpoint n (USBTXFUNCADDRn)

Base 0x4005.0000
Offset 0x080
Type R/W, reset 0x00

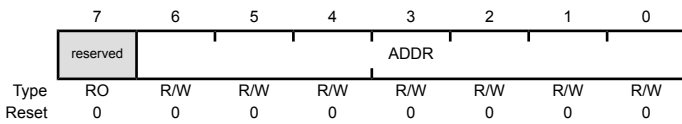

Bit/Field	Name	Type	Reset	Description
7	reserved	RO	0	Software should not rely on the value of a reserved bit. To provide compatibility with future products, the value of a reserved bit should be preserved across a read-modify-write operation.
6:0	ADDR	R/W	0x00	Device Address Specifies the USB bus address for the target Device.

Register 37: USB Transmit Hub Address Endpoint 0 (USBTXHUBADDR0), offset 0x082

Register 38: USB Transmit Hub Address Endpoint 1 (USBTXHUBADDR1), offset 0x08A

Register 39: USB Transmit Hub Address Endpoint 2 (USBTXHUBADDR2), offset 0x092

Register 40: USB Transmit Hub Address Endpoint 3 (USBTXHUBADDR3), offset 0x09A

Register 41: USB Transmit Hub Address Endpoint 4 (USBTXHUBADDR4), offset 0x0A2

Register 42: USB Transmit Hub Address Endpoint 5 (USBTXHUBADDR5), offset 0x0AA

Register 43: USB Transmit Hub Address Endpoint 6 (USBTXHUBADDR6), offset 0x0B2

Register 44: USB Transmit Hub Address Endpoint 7 (USBTXHUBADDR7), offset 0x0BA

**OTG A /
Host**

USBTXHUBADDR_n is an 8-bit read/write register that, like **USBTXHUBPORT_n**, only must be written when a USB Device is connected to transmit endpoint **EP_n** via a USB 2.0 hub. This register records the address of the USB 2.0 hub through which the target associated with the endpoint is accessed.

Note: **USBTXHUBADDR0** is used for both receive and transmit for endpoint 0.

USB Transmit Hub Address Endpoint n (USBTXHUBADDRn)

Base 0x4005.0000
Offset 0x082
Type R/W, reset 0x00

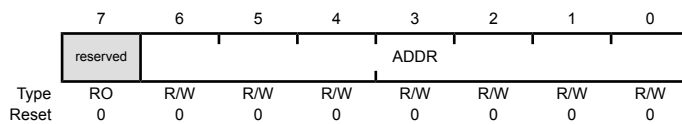

Bit/Field	Name	Type	Reset	Description
7	reserved	RO	0	Software should not rely on the value of a reserved bit. To provide compatibility with future products, the value of a reserved bit should be preserved across a read-modify-write operation.
6:0	ADDR	R/W	0x00	Hub Address This field specifies the USB bus address for the USB 2.0 hub.

Register 45: USB Transmit Hub Port Endpoint 0 (USBTXHUBPORT0), offset 0x083

Register 46: USB Transmit Hub Port Endpoint 1 (USBTXHUBPORT1), offset 0x08B

Register 47: USB Transmit Hub Port Endpoint 2 (USBTXHUBPORT2), offset 0x093

Register 48: USB Transmit Hub Port Endpoint 3 (USBTXHUBPORT3), offset 0x09B

Register 49: USB Transmit Hub Port Endpoint 4 (USBTXHUBPORT4), offset 0x0A3

Register 50: USB Transmit Hub Port Endpoint 5 (USBTXHUBPORT5), offset 0x0AB

Register 51: USB Transmit Hub Port Endpoint 6 (USBTXHUBPORT6), offset 0x0B3

Register 52: USB Transmit Hub Port Endpoint 7 (USBTXHUBPORT7), offset 0x0BB

**OTG A /
Host**

USBTXHUBPORT_n is an 8-bit read/write register that, like **USBTXHUBADDR_n**, only must be written when a full- or low-speed Device is connected to transmit endpoint EP_n via a USB 2.0 hub. This register records the port of the USB 2.0 hub through which the target associated with the endpoint is accessed.

Note: **USBTXHUBPORT0** is used for both receive and transmit for endpoint 0.

USB Transmit Hub Port Endpoint n (USBTXHUBPORT_n)

Base 0x4005.0000
Offset 0x083
Type R/W, reset 0x00

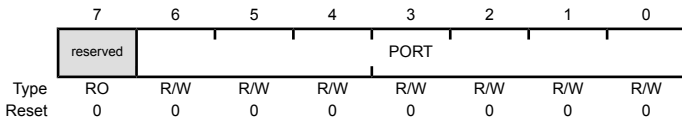

Bit/Field	Name	Type	Reset	Description
7	reserved	RO	0	Software should not rely on the value of a reserved bit. To provide compatibility with future products, the value of a reserved bit should be preserved across a read-modify-write operation.
6:0	PORT	R/W	0x00	Hub Port This field specifies the USB hub port number.

Register 53: USB Receive Functional Address Endpoint 1 (USBXFUNCADDR1), offset 0x08C

Register 54: USB Receive Functional Address Endpoint 2 (USBXFUNCADDR2), offset 0x094

Register 55: USB Receive Functional Address Endpoint 3 (USBXFUNCADDR3), offset 0x09C

Register 56: USB Receive Functional Address Endpoint 4 (USBXFUNCADDR4), offset 0x0A4

Register 57: USB Receive Functional Address Endpoint 5 (USBXFUNCADDR5), offset 0x0AC

Register 58: USB Receive Functional Address Endpoint 6 (USBXFUNCADDR6), offset 0x0B4

Register 59: USB Receive Functional Address Endpoint 7 (USBXFUNCADDR7), offset 0x0BC

**OTG A /
Host**

USBXFUNCADDR_n is an 8-bit read/write register that records the address of the target function accessed through the associated endpoint (EP_n). **USBXFUNCADDR_n** must be defined for each receive endpoint that is used.

Note: **USBTXFUNCADDR0** is used for both receive and transmit for endpoint 0.

USB Receive Functional Address Endpoint n (USBXFUNCADDR_n)

Base 0x4005.0000
Offset 0x08C
Type R/W, reset 0x00

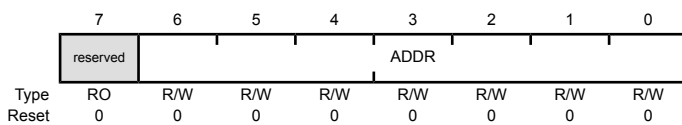

Bit/Field	Name	Type	Reset	Description
7	reserved	RO	0	Software should not rely on the value of a reserved bit. To provide compatibility with future products, the value of a reserved bit should be preserved across a read-modify-write operation.
6:0	ADDR	R/W	0x00	Device Address This field specifies the USB bus address for the target Device.

Register 60: USB Receive Hub Address Endpoint 1 (USBRXHUBADDR1), offset 0x08E

Register 61: USB Receive Hub Address Endpoint 2 (USBRXHUBADDR2), offset 0x096

Register 62: USB Receive Hub Address Endpoint 3 (USBRXHUBADDR3), offset 0x09E

Register 63: USB Receive Hub Address Endpoint 4 (USBRXHUBADDR4), offset 0x0A6

Register 64: USB Receive Hub Address Endpoint 5 (USBRXHUBADDR5), offset 0x0AE

Register 65: USB Receive Hub Address Endpoint 6 (USBRXHUBADDR6), offset 0x0B6

Register 66: USB Receive Hub Address Endpoint 7 (USBRXHUBADDR7), offset 0x0BE

OTG A /
Host

USBRXHUBADDRn is an 8-bit read/write register that, like USBRXHUBPORTn, only must be written when a full- or low-speed Device is connected to receive endpoint EPn via a USB 2.0 hub. This register records the address of the USB 2.0 hub through which the target associated with the endpoint is accessed.

Note: USBTXHUBADDR0 is used for both receive and transmit for endpoint 0.

USB Receive Hub Address Endpoint n (USBRXHUBADDRn)

Base 0x4005.0000
Offset 0x08E
Type R/W, reset 0x00

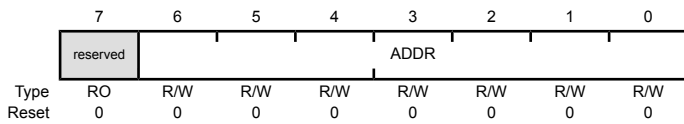

Bit/Field	Name	Type	Reset	Description
7	reserved	RO	0	Software should not rely on the value of a reserved bit. To provide compatibility with future products, the value of a reserved bit should be preserved across a read-modify-write operation.
6:0	ADDR	R/W	0x00	Hub Address This field specifies the USB bus address for the USB 2.0 hub.

Register 67: USB Receive Hub Port Endpoint 1 (USBRXHUBPORT1), offset 0x08F

Register 68: USB Receive Hub Port Endpoint 2 (USBRXHUBPORT2), offset 0x097

Register 69: USB Receive Hub Port Endpoint 3 (USBRXHUBPORT3), offset 0x09F

Register 70: USB Receive Hub Port Endpoint 4 (USBRXHUBPORT4), offset 0x0A7

Register 71: USB Receive Hub Port Endpoint 5 (USBRXHUBPORT5), offset 0x0AF

Register 72: USB Receive Hub Port Endpoint 6 (USBRXHUBPORT6), offset 0x0B7

Register 73: USB Receive Hub Port Endpoint 7 (USBRXHUBPORT7), offset 0x0BF

**OTG A /
Host**

USBRXHUBPORT_n is an 8-bit read/write register that, like **USBRXHUBADDR_n**, only must be written when a full- or low-speed Device is connected to receive endpoint EP_n via a USB 2.0 hub. This register records the port of the USB 2.0 hub through which the target associated with the endpoint is accessed.

Note: **USBTXHUBPORT0** is used for both receive and transmit for endpoint 0.

USB Receive Hub Port Endpoint n (USBRXHUBPORT_n)

Base 0x4005.0000
Offset 0x08F
Type R/W, reset 0x00

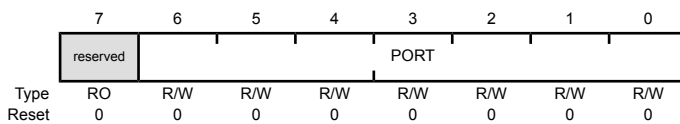

Bit/Field	Name	Type	Reset	Description
7	reserved	RO	0	Software should not rely on the value of a reserved bit. To provide compatibility with future products, the value of a reserved bit should be preserved across a read-modify-write operation.
6:0	PORT	R/W	0x00	Hub Port This field specifies the USB hub port number.

Register 74: USB Maximum Transmit Data Endpoint 1 (USBTXMAXP1), offset 0x110

Register 75: USB Maximum Transmit Data Endpoint 2 (USBTXMAXP2), offset 0x120

Register 76: USB Maximum Transmit Data Endpoint 3 (USBTXMAXP3), offset 0x130

Register 77: USB Maximum Transmit Data Endpoint 4 (USBTXMAXP4), offset 0x140

Register 78: USB Maximum Transmit Data Endpoint 5 (USBTXMAXP5), offset 0x150

Register 79: USB Maximum Transmit Data Endpoint 6 (USBTXMAXP6), offset 0x160

Register 80: USB Maximum Transmit Data Endpoint 7 (USBTXMAXP7), offset 0x170

OTG A /
Host

The **USBTXMAXPn** 16-bit register defines the maximum amount of data that can be transferred through the transmit endpoint in a single operation.

OTG B /
Device

Bits 10:0 define (in bytes) the maximum payload transmitted in a single transaction. The value set can be up to 1024 bytes but is subject to the constraints placed by the *USB Specification* on packet sizes for bulk, interrupt and isochronous transfers in full-speed operation.

The total amount of data represented by the value written to this register must not exceed the FIFO size for the transmit endpoint, and must not exceed half the FIFO size if double-buffering is required.

If this register is changed after packets have been sent from the endpoint, the transmit endpoint FIFO must be completely flushed (using the **FLUSH** bit in **USBTXCSRLn**) after writing the new value to this register.

Note: **USBTXMAXPn** must be set to an even number of bytes for proper interrupt generation in μ DMA Basic Mode.

USB Maximum Transmit Data Endpoint n (USBTXMAXPn)

Base 0x4005.0000
Offset 0x110
Type R/W, reset 0x0000

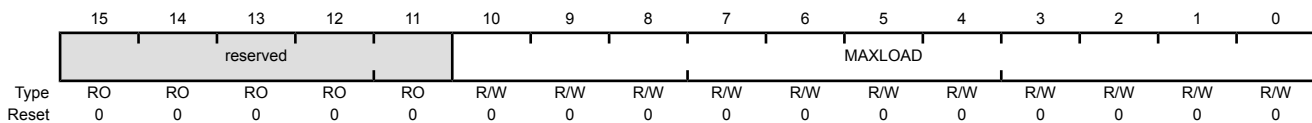

Bit/Field	Name	Type	Reset	Description
15:11	reserved	RO	0x0	Software should not rely on the value of a reserved bit. To provide compatibility with future products, the value of a reserved bit should be preserved across a read-modify-write operation.
10:0	MAXLOAD	R/W	0x000	Maximum Payload This field specifies the maximum payload in bytes per transaction.

Register 81: USB Control and Status Endpoint 0 Low (USBCSRL0), offset 0x102

OTG A /
Host

USBCSRL0 is an 8-bit register that provides control and status bits for endpoint 0.

OTG B /
Device

OTG A / Host Mode

USB Control and Status Endpoint 0 Low (USBCSRL0)

Base 0x4005.0000
Offset 0x102
Type W1C, reset 0x00

	7	6	5	4	3	2	1	0
	NAKTO	STATUS	REQPKT	ERROR	SETUP	STALLED	TXRDY	RXRDY
Type	R/W	R/W	R/W	R/W	R/W	R/W	R/W	R/W
Reset	0	0	0	0	0	0	0	0

Bit/Field	Name	Type	Reset	Description						
7	NAKTO	R/W	0	<p>NAK Timeout</p> <table border="1"> <thead> <tr> <th>Value</th> <th>Description</th> </tr> </thead> <tbody> <tr> <td>0</td> <td>No timeout.</td> </tr> <tr> <td>1</td> <td>Indicates that endpoint 0 is halted following the receipt of NAK responses for longer than the time set by the USBNAKLMT register.</td> </tr> </tbody> </table> <p>Software must clear this bit to allow the endpoint to continue.</p>	Value	Description	0	No timeout.	1	Indicates that endpoint 0 is halted following the receipt of NAK responses for longer than the time set by the USBNAKLMT register.
Value	Description									
0	No timeout.									
1	Indicates that endpoint 0 is halted following the receipt of NAK responses for longer than the time set by the USBNAKLMT register.									
6	STATUS	R/W	0	<p>STATUS Packet</p> <table border="1"> <thead> <tr> <th>Value</th> <th>Description</th> </tr> </thead> <tbody> <tr> <td>0</td> <td>No transaction.</td> </tr> <tr> <td>1</td> <td>Initiates a STATUS stage transaction. This bit must be set at the same time as the TXRDY or REQPKT bit is set.</td> </tr> </tbody> </table> <p>Setting this bit ensures that the DT bit is set in the USBCSRH0 register so that a DATA1 packet is used for the STATUS stage transaction. This bit is automatically cleared when the STATUS stage is over.</p>	Value	Description	0	No transaction.	1	Initiates a STATUS stage transaction. This bit must be set at the same time as the TXRDY or REQPKT bit is set.
Value	Description									
0	No transaction.									
1	Initiates a STATUS stage transaction. This bit must be set at the same time as the TXRDY or REQPKT bit is set.									
5	REQPKT	R/W	0	<p>Request Packet</p> <table border="1"> <thead> <tr> <th>Value</th> <th>Description</th> </tr> </thead> <tbody> <tr> <td>0</td> <td>No request.</td> </tr> <tr> <td>1</td> <td>Requests an IN transaction.</td> </tr> </tbody> </table> <p>This bit is cleared when the RXRDY bit is set.</p>	Value	Description	0	No request.	1	Requests an IN transaction.
Value	Description									
0	No request.									
1	Requests an IN transaction.									

Bit/Field	Name	Type	Reset	Description
4	ERROR	R/W	0	<p>Error</p> <p>Value Description</p> <p>0 No error.</p> <p>1 Three attempts have been made to perform a transaction with no response from the peripheral. The <code>EP0</code> bit in the USBTXIS register is also set in this situation.</p> <p>Software must clear this bit.</p>
3	SETUP	R/W	0	<p>Setup Packet</p> <p>Value Description</p> <p>0 Sends an OUT token.</p> <p>1 Sends a SETUP token instead of an OUT token for the transaction. This bit should be set at the same time as the <code>TXRDY</code> bit is set.</p> <p>Setting this bit always clears the <code>DT</code> bit in the USBCSRH0 register to send a <code>DATA0</code> packet.</p>
2	STALLED	R/W	0	<p>Endpoint Stalled</p> <p>Value Description</p> <p>0 No handshake has been received.</p> <p>1 A STALL handshake has been received.</p> <p>Software must clear this bit.</p>
1	TXRDY	R/W	0	<p>Transmit Packet Ready</p> <p>Value Description</p> <p>0 No transmit packet is ready.</p> <p>1 Software sets this bit after loading a data packet into the TX FIFO. The <code>EP0</code> bit in the USBTXIS register is also set in this situation.</p> <p>If both the <code>TXRDY</code> and <code>SETUP</code> bits are set, a setup packet is sent. If just <code>TXRDY</code> is set, an OUT packet is sent.</p> <p>This bit is cleared automatically when the data packet has been transmitted.</p>
0	RXRDY	R/W	0	<p>Receive Packet Ready</p> <p>Value Description</p> <p>0 No received packet has been received.</p> <p>1 Indicates that a data packet has been received in the RX FIFO. The <code>EP0</code> bit in the USBTXIS register is also set in this situation.</p> <p>Software must clear this bit after the packet has been read from the FIFO to acknowledge that the data has been read from the FIFO.</p>

OTG B / Device Mode

USB Control and Status Endpoint 0 Low (USBCSRL0)

Base 0x4005.0000
 Offset 0x102
 Type W1C, reset 0x00

	7	6	5	4	3	2	1	0
	SETENDC	RXRDYC	STALL	SETEND	DATAEND	STALLED	TXRDY	RXRDY
Type	W1C	W1C	R/W	RO	R/W	R/W	R/W	RO
Reset	0	0	0	0	0	0	0	0

Bit/Field	Name	Type	Reset	Description						
7	SETENDC	W1C	0	Setup End Clear Writing a 1 to this bit clears the SETEND bit.						
6	RXRDYC	W1C	0	RXRDY Clear Writing a 1 to this bit clears the RXRDY bit.						
5	STALL	R/W	0	Send Stall <table border="0"> <tr> <td>Value</td> <td>Description</td> </tr> <tr> <td>0</td> <td>No effect.</td> </tr> <tr> <td>1</td> <td>Terminates the current transaction and transmits the STALL handshake.</td> </tr> </table> This bit is cleared automatically after the STALL handshake is transmitted.	Value	Description	0	No effect.	1	Terminates the current transaction and transmits the STALL handshake.
Value	Description									
0	No effect.									
1	Terminates the current transaction and transmits the STALL handshake.									
4	SETEND	RO	0	Setup End <table border="0"> <tr> <td>Value</td> <td>Description</td> </tr> <tr> <td>0</td> <td>A control transaction has not ended or ended after the DATAEND bit was set.</td> </tr> <tr> <td>1</td> <td>A control transaction has ended before the DATAEND bit has been set. The EP0 bit in the USBTXIS register is also set in this situation.</td> </tr> </table> This bit is cleared by writing a 1 to the SETENDC bit.	Value	Description	0	A control transaction has not ended or ended after the DATAEND bit was set.	1	A control transaction has ended before the DATAEND bit has been set. The EP0 bit in the USBTXIS register is also set in this situation.
Value	Description									
0	A control transaction has not ended or ended after the DATAEND bit was set.									
1	A control transaction has ended before the DATAEND bit has been set. The EP0 bit in the USBTXIS register is also set in this situation.									
3	DATAEND	R/W	0	Data End <table border="0"> <tr> <td>Value</td> <td>Description</td> </tr> <tr> <td>0</td> <td>No effect.</td> </tr> <tr> <td>1</td> <td>Set this bit in the following situations: <ul style="list-style-type: none"> ■ When setting TXRDY for the last data packet ■ When clearing RXRDY after unloading the last data packet ■ When setting TXRDY for a zero-length data packet </td> </tr> </table> This bit is cleared automatically.	Value	Description	0	No effect.	1	Set this bit in the following situations: <ul style="list-style-type: none"> ■ When setting TXRDY for the last data packet ■ When clearing RXRDY after unloading the last data packet ■ When setting TXRDY for a zero-length data packet
Value	Description									
0	No effect.									
1	Set this bit in the following situations: <ul style="list-style-type: none"> ■ When setting TXRDY for the last data packet ■ When clearing RXRDY after unloading the last data packet ■ When setting TXRDY for a zero-length data packet 									

Bit/Field	Name	Type	Reset	Description
2	STALLED	R/W	0	<p>Endpoint Stalled</p> <p>Value Description</p> <p>0 A STALL handshake has not been transmitted.</p> <p>1 A STALL handshake has been transmitted.</p> <p>Software must clear this bit.</p>
1	TXRDY	R/W	0	<p>Transmit Packet Ready</p> <p>Value Description</p> <p>0 No transmit packet is ready.</p> <p>1 Software sets this bit after loading an IN data packet into the TX FIFO. The EP0 bit in the USBTXIS register is also set in this situation.</p> <p>This bit is cleared automatically when the data packet has been transmitted.</p>
0	RXRDY	RO	0	<p>Receive Packet Ready</p> <p>Value Description</p> <p>0 No data packet has been received.</p> <p>1 A data packet has been received. The EP0 bit in the USBTXIS register is also set in this situation.</p> <p>This bit is cleared by writing a 1 to the RXRDYC bit.</p>

Register 82: USB Control and Status Endpoint 0 High (USBCSRH0), offset 0x103

OTG A /
Host

USBSR0H is an 8-bit register that provides control and status bits for endpoint 0.

OTG B /
Device

OTG A / Host Mode

USB Control and Status Endpoint 0 High (USBCSRH0)

Base 0x4005.0000
Offset 0x103
Type W1C, reset 0x00

	7	6	5	4	3	2	1	0
	reserved					DTWE	DT	FLUSH
Type	RO	RO	RO	RO	RO	R/W	R/W	R/W
Reset	0	0	0	0	0	0	0	0

Bit/Field	Name	Type	Reset	Description
7:3	reserved	RO	0x0	Software should not rely on the value of a reserved bit. To provide compatibility with future products, the value of a reserved bit should be preserved across a read-modify-write operation.
2	DTWE	R/W	0	Data Toggle Write Enable Value Description 0 The DT bit cannot be written. 1 Enables the current state of the endpoint 0 data toggle to be written (see DT bit). This bit is automatically cleared once the new value is written.
1	DT	R/W	0	Data Toggle When read, this bit indicates the current state of the endpoint 0 data toggle. If DTWE is set, this bit may be written with the required setting of the data toggle. If DTWE is Low, this bit cannot be written. Care should be taken when writing to this bit as it should only be changed to RESET USB endpoint 0.

Bit/Field	Name	Type	Reset	Description
0	FLUSH	R/W	0	Flush FIFO

Value	Description
0	No effect.
1	Flushes the next packet to be transmitted/read from the endpoint 0 FIFO. The FIFO pointer is reset and the TXRDY/RXRDY bit is cleared.

This bit is automatically cleared after the flush is performed.

Important: This bit should only be set when TXRDY/RXRDY is set. At other times, it may cause data to be corrupted.

OTG B / Device Mode

USB Control and Status Endpoint 0 High (USBCSRH0)

Base 0x4005.0000
 Offset 0x103
 Type W1C, reset 0x00

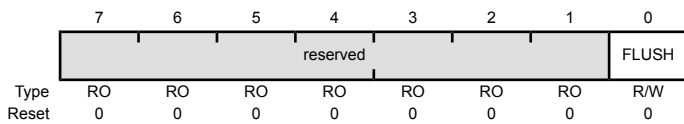

Bit/Field	Name	Type	Reset	Description
7:1	reserved	RO	0x00	Software should not rely on the value of a reserved bit. To provide compatibility with future products, the value of a reserved bit should be preserved across a read-modify-write operation.
0	FLUSH	R/W	0	Flush FIFO

Value	Description
0	No effect.
1	Flushes the next packet to be transmitted/read from the endpoint 0 FIFO. The FIFO pointer is reset and the TXRDY/RXRDY bit is cleared.

This bit is automatically cleared after the flush is performed.

Important: This bit should only be set when TXRDY/RXRDY is set. At other times, it may cause data to be corrupted.

Register 83: USB Receive Byte Count Endpoint 0 (USBCOUNT0), offset 0x108

OTG A /
Host

USBCOUNT0 is an 8-bit read-only register that indicates the number of received data bytes in the endpoint 0 FIFO. The value returned changes as the contents of the FIFO change and is only valid while the `RXRDY` bit is set.

OTG B /
Device

USB Receive Byte Count Endpoint 0 (USBCOUNT0)

Base 0x4005.0000
Offset 0x108
Type RO, reset 0x00

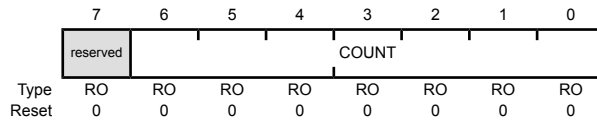

Bit/Field	Name	Type	Reset	Description
7	reserved	RO	0	Software should not rely on the value of a reserved bit. To provide compatibility with future products, the value of a reserved bit should be preserved across a read-modify-write operation.
6:0	COUNT	RO	0x00	FIFO Count COUNT is a read-only value that indicates the number of received data bytes in the endpoint 0 FIFO.

Register 84: USB Type Endpoint 0 (USBTYPE0), offset 0x10A

**OTG A /
Host**

This is an 8-bit register that must be written with the operating speed of the targeted Device being communicated with using endpoint 0.

USB Type Endpoint 0 (USBTYPE0)

Base 0x4005.0000

Offset 0x10A

Type R/W, reset 0x00

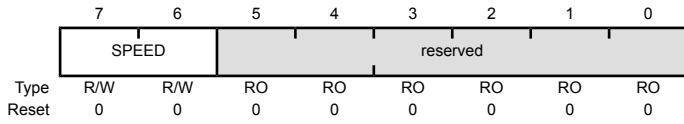

Bit/Field	Name	Type	Reset	Description
7:6	SPEED	R/W	0x0	Operating Speed This field specifies the operating speed of the target Device. If selected, the target is assumed to have the same connection speed as the USB controller. Value Description 0x0 - 0x1 Reserved 0x2 Full 0x3 Low
5:0	reserved	RO	0x0	Software should not rely on the value of a reserved bit. To provide compatibility with future products, the value of a reserved bit should be preserved across a read-modify-write operation.

Register 85: USB NAK Limit (USBNAKLMT), offset 0x10B

OTG A /
Host

USBNAKLMT is an 8-bit register that sets the number of frames after which endpoint 0 should time out on receiving a stream of NAK responses. (Equivalent settings for other endpoints can be made through their **USBTXINTERVALn** and **USBRXINTERVALn** registers.)

The number of frames selected is $2^{(m-1)}$ (where m is the value set in the register, with valid values of 2–16). If the Host receives NAK responses from the target for more frames than the number represented by the limit set in this register, the endpoint is halted.

Note: A value of 0 or 1 disables the NAK timeout function.

USB NAK Limit (USBNAKLMT)

Base 0x4005.0000
Offset 0x10B
Type R/W, reset 0x00

	7	6	5	4	3	2	1	0
	reserved			NAKLMT				
Type	RO	RO	RO	R/W	R/W	R/W	R/W	R/W
Reset	0	0	0	0	0	0	0	0

Bit/Field	Name	Type	Reset	Description
7:5	reserved	RO	0x0	Software should not rely on the value of a reserved bit. To provide compatibility with future products, the value of a reserved bit should be preserved across a read-modify-write operation.
4:0	NAKLMT	R/W	0x0	EP0 NAK Limit This field specifies the number of frames after receiving a stream of NAK responses.

Register 86: USB Transmit Control and Status Endpoint 1 Low (USBTXCSRL1), offset 0x112

Register 87: USB Transmit Control and Status Endpoint 2 Low (USBTXCSRL2), offset 0x122

Register 88: USB Transmit Control and Status Endpoint 3 Low (USBTXCSRL3), offset 0x132

Register 89: USB Transmit Control and Status Endpoint 4 Low (USBTXCSRL4), offset 0x142

Register 90: USB Transmit Control and Status Endpoint 5 Low (USBTXCSRL5), offset 0x152

Register 91: USB Transmit Control and Status Endpoint 6 Low (USBTXCSRL6), offset 0x162

Register 92: USB Transmit Control and Status Endpoint 7 Low (USBTXCSRL7), offset 0x172

OTG A /
Host

USBTXCSRLn is an 8-bit register that provides control and status bits for transfers through the currently selected transmit endpoint.

OTG B /
Device

OTG A / Host Mode

USB Transmit Control and Status Endpoint n Low (USBTXCSRLn)

Base 0x4005.0000
Offset 0x112
Type R/W, reset 0x00

	7	6	5	4	3	2	1	0
	NAKTO	CLRDT	STALLED	SETUP	FLUSH	ERROR	FIFONE	TXRDY
Type	R/W	R/W	R/W	R/W	R/W	R/W	R/W	R/W
Reset	0	0	0	0	0	0	0	0

Bit/Field	Name	Type	Reset	Description
7	NAKTO	R/W	0	NAK Timeout

Value	Description
0	No timeout.
1	<i>Bulk endpoints only:</i> Indicates that the transmit endpoint is halted following the receipt of NAK responses for longer than the time set by the NAKLMT field in the USBTXINTERVALn register. Software must clear this bit to allow the endpoint to continue.

Bit/Field	Name	Type	Reset	Description
6	CLRDT	R/W	0	<p>Clear Data Toggle</p> <p>Writing a 1 to this bit clears the DT bit in the USBTXCSRHn register.</p>
5	STALLED	R/W	0	<p>Endpoint Stalled</p> <p>Value Description</p> <p>0 A STALL handshake has not been received.</p> <p>1 Indicates that a STALL handshake has been received. When this bit is set, any μDMA request that is in progress is stopped, the FIFO is completely flushed, and the TXRDY bit is cleared.</p> <p>Software must clear this bit.</p>
4	SETUP	R/W	0	<p>Setup Packet</p> <p>Value Description</p> <p>0 No SETUP token is sent.</p> <p>1 Sends a SETUP token instead of an OUT token for the transaction. This bit should be set at the same time as the TXRDY bit is set.</p> <p>Note: Setting this bit also clears the DT bit in the USBTXCSRHn register.</p>
3	FLUSH	R/W	0	<p>Flush FIFO</p> <p>Value Description</p> <p>0 No effect.</p> <p>1 Flushes the latest packet from the endpoint transmit FIFO. The FIFO pointer is reset and the TXRDY bit is cleared. The EPn bit in the USBTXIS register is also set in this situation.</p> <p>This bit may be set simultaneously with the TXRDY bit to abort the packet that is currently being loaded into the FIFO. Note that if the FIFO is double-buffered, FLUSH may have to be set twice to completely clear the FIFO.</p> <hr/> <p>Important: This bit should only be set when the TXRDY bit is set. At other times, it may cause data to be corrupted.</p> <hr/>
2	ERROR	R/W	0	<p>Error</p> <p>Value Description</p> <p>0 No error.</p> <p>1 Three attempts have been made to send a packet and no handshake packet has been received. The TXRDY bit is cleared, the EPn bit in the USBTXIS register is set, and the FIFO is completely flushed in this situation.</p> <p>Software must clear this bit.</p> <p>Note: This is valid only when the endpoint is operating in Bulk or Interrupt mode.</p>

Bit/Field	Name	Type	Reset	Description
1	FIFONE	R/W	0	FIFO Not Empty Value Description 0 The FIFO is empty. 1 At least one packet is in the transmit FIFO.
0	TXRDY	R/W	0	Transmit Packet Ready Value Description 0 No transmit packet is ready. 1 Software sets this bit after loading a data packet into the TX FIFO. This bit is cleared automatically when a data packet has been transmitted. The EP_n bit in the USBTXIS register is also set at this point. TXRDY is also automatically cleared prior to loading a second packet into a double-buffered FIFO.

OTG B / Device Mode

USB Transmit Control and Status Endpoint n Low (USBTXCSSLn)

Base 0x4005.0000
Offset 0x112
Type R/W, reset 0x00

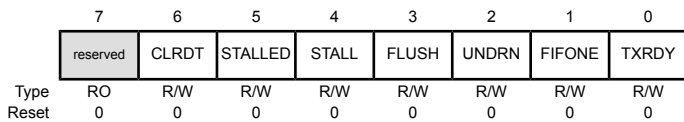

Bit/Field	Name	Type	Reset	Description
7	reserved	RO	0	Software should not rely on the value of a reserved bit. To provide compatibility with future products, the value of a reserved bit should be preserved across a read-modify-write operation.
6	CLRDT	R/W	0	Clear Data Toggle Writing a 1 to this bit clears the DT bit in the USBTXCSRHn register.
5	STALLED	R/W	0	Endpoint Stalled Value Description 0 A STALL handshake has not been transmitted. 1 A STALL handshake has been transmitted. The FIFO is flushed and the TXRDY bit is cleared. Software must clear this bit.

Bit/Field	Name	Type	Reset	Description
4	STALL	R/W	0	<p>Send STALL</p> <p>Value Description</p> <p>0 No effect.</p> <p>1 Issues a STALL handshake to an IN token.</p> <p>Software clears this bit to terminate the STALL condition.</p> <p>Note: This bit has no effect in isochronous transfers.</p>
3	FLUSH	R/W	0	<p>Flush FIFO</p> <p>Value Description</p> <p>0 No effect.</p> <p>1 Flushes the latest packet from the endpoint transmit FIFO. The FIFO pointer is reset and the TXRDY bit is cleared. The EPn bit in the USBTXIS register is also set in this situation.</p> <p>This bit may be set simultaneously with the TXRDY bit to abort the packet that is currently being loaded into the FIFO. Note that if the FIFO is double-buffered, FLUSH may have to be set twice to completely clear the FIFO.</p> <p>Important: This bit should only be set when the TXRDY bit is set. At other times, it may cause data to be corrupted.</p>
2	UNDRN	R/W	0	<p>Underrun</p> <p>Value Description</p> <p>0 No underrun.</p> <p>1 An IN token has been received when TXRDY is not set.</p> <p>Software must clear this bit.</p>
1	FIFONE	R/W	0	<p>FIFO Not Empty</p> <p>Value Description</p> <p>0 The FIFO is empty.</p> <p>1 At least one packet is in the transmit FIFO.</p>
0	TXRDY	R/W	0	<p>Transmit Packet Ready</p> <p>Value Description</p> <p>0 No transmit packet is ready.</p> <p>1 Software sets this bit after loading a data packet into the TX FIFO.</p> <p>This bit is cleared automatically when a data packet has been transmitted. The EPn bit in the USBTXIS register is also set at this point. TXRDY is also automatically cleared prior to loading a second packet into a double-buffered FIFO.</p>

Register 93: USB Transmit Control and Status Endpoint 1 High (USBTXCSRH1), offset 0x113

Register 94: USB Transmit Control and Status Endpoint 2 High (USBTXCSRH2), offset 0x123

Register 95: USB Transmit Control and Status Endpoint 3 High (USBTXCSRH3), offset 0x133

Register 96: USB Transmit Control and Status Endpoint 4 High (USBTXCSRH4), offset 0x143

Register 97: USB Transmit Control and Status Endpoint 5 High (USBTXCSRH5), offset 0x153

Register 98: USB Transmit Control and Status Endpoint 6 High (USBTXCSRH6), offset 0x163

Register 99: USB Transmit Control and Status Endpoint 7 High (USBTXCSRH7), offset 0x173

OTG A /
Host

USBTXCSRHn is an 8-bit register that provides additional control for transfers through the currently selected transmit endpoint.

OTG B /
Device

OTG A / Host Mode

USB Transmit Control and Status Endpoint n High (USBTXCSRHn)

Base 0x4005.0000
Offset 0x113
Type R/W, reset 0x00

	7	6	5	4	3	2	1	0
	AUTOSET	reserved	MODE	DMAEN	FDT	DMAMOD	DTWE	DT
Type	R/W	RO	R/W	R/W	R/W	R/W	R/W	R/W
Reset	0	0	0	0	0	0	0	0

Bit/Field	Name	Type	Reset	Description
7	AUTOSET	R/W	0	Auto Set

Value	Description
0	The TXRDY bit must be set manually.
1	Enables the TXRDY bit to be automatically set when data of the maximum packet size (value in USBTXMAXPn) is loaded into the transmit FIFO. If a packet of less than the maximum packet size is loaded, then the TXRDY bit must be set manually.

Bit/Field	Name	Type	Reset	Description
6	reserved	RO	0	Software should not rely on the value of a reserved bit. To provide compatibility with future products, the value of a reserved bit should be preserved across a read-modify-write operation.
5	MODE	R/W	0	<p>Mode</p> <p>Value Description</p> <p>0 Enables the endpoint direction as RX.</p> <p>1 Enables the endpoint direction as TX.</p> <p>Note: This bit only has an effect when the same endpoint FIFO is used for both transmit and receive transactions.</p>
4	DMAEN	R/W	0	<p>DMA Request Enable</p> <p>Value Description</p> <p>0 Disables the μDMA request for the transmit endpoint.</p> <p>1 Enables the μDMA request for the transmit endpoint.</p> <p>Note: 3 TX and 3 /RX endpoints can be connected to the μDMA module. If this bit is set for a particular endpoint, the DMAATX, DMABTX, or DMACTX field in the USB DMA Select (USBDMASEL) register must be programmed correspondingly.</p>
3	FDT	R/W	0	<p>Force Data Toggle</p> <p>Value Description</p> <p>0 No effect.</p> <p>1 Forces the endpoint DT bit to switch and the data packet to be cleared from the FIFO, regardless of whether an ACK was received. This bit can be used by interrupt transmit endpoints that are used to communicate rate feedback for isochronous endpoints.</p>
2	DMAMOD	R/W	0	<p>DMA Request Mode</p> <p>Value Description</p> <p>0 An interrupt is generated after every μDMA packet transfer.</p> <p>1 An interrupt is generated only after the entire μDMA transfer is complete.</p> <p>Note: This bit must not be cleared either before or in the same cycle as the above DMAEN bit is cleared.</p>
1	DTWE	R/W	0	<p>Data Toggle Write Enable</p> <p>Value Description</p> <p>0 The DT bit cannot be written.</p> <p>1 Enables the current state of the transmit endpoint data to be written (see DT bit).</p> <p>This bit is automatically cleared once the new value is written.</p>

Bit/Field	Name	Type	Reset	Description
0	DT	R/W	0	<p>Data Toggle</p> <p>When read, this bit indicates the current state of the transmit endpoint data toggle.</p> <p>If <i>DTWE</i> is High, this bit may be written with the required setting of the data toggle. If <i>DTWE</i> is Low, any value written to this bit is ignored. Care should be taken when writing to this bit as it should only be changed to RESET the transmit endpoint.</p>

OTG B / Device Mode

USB Transmit Control and Status Endpoint n High (USBTXCSRHn)

Base 0x4005.0000
 Offset 0x113
 Type R/W, reset 0x00

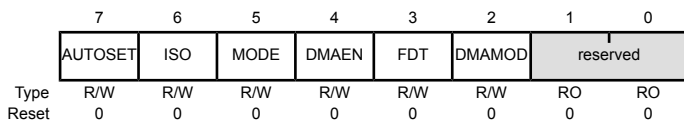

Bit/Field	Name	Type	Reset	Description						
7	AUTOSET	R/W	0	<p>Auto Set</p> <table border="1"> <thead> <tr> <th>Value</th> <th>Description</th> </tr> </thead> <tbody> <tr> <td>0</td> <td>The <i>TXRDY</i> bit must be set manually.</td> </tr> <tr> <td>1</td> <td>Enables the <i>TXRDY</i> bit to be automatically set when data of the maximum packet size (value in USBTXMAXPn) is loaded into the transmit FIFO. If a packet of less than the maximum packet size is loaded, then the <i>TXRDY</i> bit must be set manually.</td> </tr> </tbody> </table>	Value	Description	0	The <i>TXRDY</i> bit must be set manually.	1	Enables the <i>TXRDY</i> bit to be automatically set when data of the maximum packet size (value in USBTXMAXPn) is loaded into the transmit FIFO. If a packet of less than the maximum packet size is loaded, then the <i>TXRDY</i> bit must be set manually.
Value	Description									
0	The <i>TXRDY</i> bit must be set manually.									
1	Enables the <i>TXRDY</i> bit to be automatically set when data of the maximum packet size (value in USBTXMAXPn) is loaded into the transmit FIFO. If a packet of less than the maximum packet size is loaded, then the <i>TXRDY</i> bit must be set manually.									
6	ISO	R/W	0	<p>Isochronous Transfers</p> <table border="1"> <thead> <tr> <th>Value</th> <th>Description</th> </tr> </thead> <tbody> <tr> <td>0</td> <td>Enables the transmit endpoint for bulk or interrupt transfers.</td> </tr> <tr> <td>1</td> <td>Enables the transmit endpoint for isochronous transfers.</td> </tr> </tbody> </table>	Value	Description	0	Enables the transmit endpoint for bulk or interrupt transfers.	1	Enables the transmit endpoint for isochronous transfers.
Value	Description									
0	Enables the transmit endpoint for bulk or interrupt transfers.									
1	Enables the transmit endpoint for isochronous transfers.									
5	MODE	R/W	0	<p>Mode</p> <table border="1"> <thead> <tr> <th>Value</th> <th>Description</th> </tr> </thead> <tbody> <tr> <td>0</td> <td>Enables the endpoint direction as RX.</td> </tr> <tr> <td>1</td> <td>Enables the endpoint direction as TX.</td> </tr> </tbody> </table> <p>Note: This bit only has an effect where the same endpoint FIFO is used for both transmit and receive transactions.</p>	Value	Description	0	Enables the endpoint direction as RX.	1	Enables the endpoint direction as TX.
Value	Description									
0	Enables the endpoint direction as RX.									
1	Enables the endpoint direction as TX.									

Bit/Field	Name	Type	Reset	Description
4	DMAEN	R/W	0	<p>DMA Request Enable</p> <p>Value Description</p> <p>0 Disables the μDMA request for the transmit endpoint.</p> <p>1 Enables the μDMA request for the transmit endpoint.</p> <p>Note: 3 TX and 3 RX endpoints can be connected to the μDMA module. If this bit is set for a particular endpoint, the DMAATX, DMABTX, or DMACTX field in the USB DMA Select (USBDMASEL) register must be programmed correspondingly.</p>
3	FDT	R/W	0	<p>Force Data Toggle</p> <p>Value Description</p> <p>0 No effect.</p> <p>1 Forces the endpoint DT bit to switch and the data packet to be cleared from the FIFO, regardless of whether an ACK was received. This bit can be used by interrupt transmit endpoints that are used to communicate rate feedback for isochronous endpoints.</p>
2	DMAMOD	R/W	0	<p>DMA Request Mode</p> <p>Value Description</p> <p>0 An interrupt is generated after every μDMA packet transfer.</p> <p>1 An interrupt is generated only after the entire μDMA transfer is complete.</p> <p>Note: This bit must not be cleared either before or in the same cycle as the above DMAEN bit is cleared.</p>
1:0	reserved	RO	0	Software should not rely on the value of a reserved bit. To provide compatibility with future products, the value of a reserved bit should be preserved across a read-modify-write operation.

Register 100: USB Maximum Receive Data Endpoint 1 (USBRXMAXP1), offset 0x114

Register 101: USB Maximum Receive Data Endpoint 2 (USBRXMAXP2), offset 0x124

Register 102: USB Maximum Receive Data Endpoint 3 (USBRXMAXP3), offset 0x134

Register 103: USB Maximum Receive Data Endpoint 4 (USBRXMAXP4), offset 0x144

Register 104: USB Maximum Receive Data Endpoint 5 (USBRXMAXP5), offset 0x154

Register 105: USB Maximum Receive Data Endpoint 6 (USBRXMAXP6), offset 0x164

Register 106: USB Maximum Receive Data Endpoint 7 (USBRXMAXP7), offset 0x174

**OTG A /
Host**

The **USBRXMAXPn** is a 16-bit register which defines the maximum amount of data that can be transferred through the selected receive endpoint in a single operation.

**OTG B /
Device**

Bits 10:0 define (in bytes) the maximum payload transmitted in a single transaction. The value set can be up to 1024 bytes but is subject to the constraints placed by the *USB Specification* on packet sizes for bulk, interrupt and isochronous transfers in full-speed operations.

The total amount of data represented by the value written to this register must not exceed the FIFO size for the receive endpoint, and must not exceed half the FIFO size if double-buffering is required.

Note: **USBRXMAXPn** must be set to an even number of bytes for proper interrupt generation in μ DMA Basic mode.

USB Maximum Receive Data Endpoint n (USBRXMAXPn)

Base 0x4005.0000
Offset 0x114
Type R/W, reset 0x0000

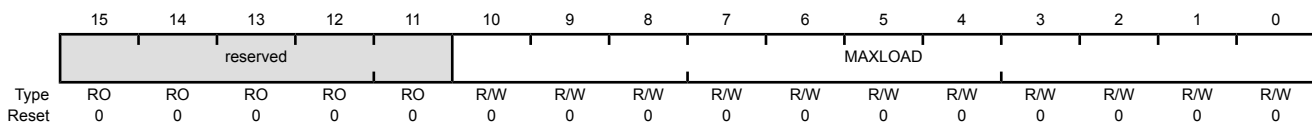

Bit/Field	Name	Type	Reset	Description
15:11	reserved	RO	0x0	Software should not rely on the value of a reserved bit. To provide compatibility with future products, the value of a reserved bit should be preserved across a read-modify-write operation.
10:0	MAXLOAD	R/W	0x000	Maximum Payload The maximum payload in bytes per transaction.

Register 107: USB Receive Control and Status Endpoint 1 Low (USBXCSRL1), offset 0x116

Register 108: USB Receive Control and Status Endpoint 2 Low (USBXCSRL2), offset 0x126

Register 109: USB Receive Control and Status Endpoint 3 Low (USBXCSRL3), offset 0x136

Register 110: USB Receive Control and Status Endpoint 4 Low (USBXCSRL4), offset 0x146

Register 111: USB Receive Control and Status Endpoint 5 Low (USBXCSRL5), offset 0x156

Register 112: USB Receive Control and Status Endpoint 6 Low (USBXCSRL6), offset 0x166

Register 113: USB Receive Control and Status Endpoint 7 Low (USBXCSRL7), offset 0x176

OTG A /
Host

USBXCSRL_n is an 8-bit register that provides control and status bits for transfers through the currently selected receive endpoint.

OTG B /
Device

OTG A / Host Mode

USB Receive Control and Status Endpoint n Low (USBXCSRL_n)

Base 0x4005.0000
Offset 0x116
Type R/W, reset 0x00

	7	6	5	4	3	2	1	0
	CLRDT	STALLED	REQPKT	FLUSH	DATAERR / NAKTO	ERROR	FULL	RXRDY
Type	W1C	R/W	R/W	R/W	R/W	R/W	RO	R/W
Reset	0	0	0	0	0	0	0	0

Bit/Field	Name	Type	Reset	Description
7	CLRDT	W1C	0	Clear Data Toggle Writing a 1 to this bit clears the DT bit in the USBXCSRH _n register.
6	STALLED	R/W	0	Endpoint Stalled Value Description 0 A STALL handshake has not been received. 1 A STALL handshake has been received. The EP _n bit in the USBXIS register is also set. Software must clear this bit.

Bit/Field	Name	Type	Reset	Description
5	REQPKT	R/W	0	<p>Request Packet</p> <p>Value Description</p> <p>0 No request.</p> <p>1 Requests an IN transaction.</p> <p>This bit is cleared when R_{XRDY} is set.</p>
4	FLUSH	R/W	0	<p>Flush FIFO</p> <p>Value Description</p> <p>0 No effect.</p> <p>1 Flushes the next packet to be read from the endpoint receive FIFO. The FIFO pointer is reset and the R_{XRDY} bit is cleared.</p> <p>Note that if the FIFO is double-buffered, FLUSH may have to be set twice to completely clear the FIFO.</p> <hr/> <p>Important: This bit should only be set when the R_{XRDY} bit is set. At other times, it may cause data to be corrupted.</p> <hr/>
3	DATAERR / NAKTO	R/W	0	<p>Data Error / NAK Timeout</p> <p>Value Description</p> <p>0 Normal operation.</p> <p>1 <i>Isochronous endpoints only:</i> Indicates that R_{XRDY} is set and the data packet has a CRC or bit-stuff error. This bit is cleared when R_{XRDY} is cleared.</p> <p><i>Bulk endpoints only:</i> Indicates that the receive endpoint is halted following the receipt of NAK responses for longer than the time set by the NAKLMT field in the USB_{RXINTERVAL}_n register. Software must clear this bit to allow the endpoint to continue.</p>
2	ERROR	R/W	0	<p>Error</p> <p>Value Description</p> <p>0 No error.</p> <p>1 Three attempts have been made to receive a packet and no data packet has been received. The EP_n bit in the USB_{RXIS} register is set in this situation.</p> <p>Software must clear this bit.</p> <p>Note: This bit is only valid when the receive endpoint is operating in Bulk or Interrupt mode. In Isochronous mode, it always returns zero.</p>
1	FULL	RO	0	<p>FIFO Full</p> <p>Value Description</p> <p>0 The receive FIFO is not full.</p> <p>1 No more packets can be loaded into the receive FIFO.</p>

Bit/Field	Name	Type	Reset	Description
0	RXRDY	R/W	0	Receive Packet Ready
				Value Description
				0 No data packet has been received.
				1 A data packet has been received. The EP _n bit in the USBRXIS register is also set in this situation.
				If the AUTOCLR bit in the USBRXCSRHn register is set, then the this bit is automatically cleared when a packet of USBRXMAXPn bytes has been unloaded from the receive FIFO. If the AUTOCLR bit is clear, or if packets of less than the maximum packet size are unloaded, then software must clear this bit manually when the packet has been unloaded from the receive FIFO.

OTG B / Device Mode

USB Receive Control and Status Endpoint n Low (USBRXCSSLn)

Base 0x4005.0000
Offset 0x116
Type R/W, reset 0x00

	7	6	5	4	3	2	1	0
	CLRDT	STALLED	STALL	FLUSH	DATAERR	OVER	FULL	RXRDY
Type	W1C	R/W	R/W	R/W	RO	R/W	RO	R/W
Reset	0	0	0	0	0	0	0	0

Bit/Field	Name	Type	Reset	Description
7	CLRDT	W1C	0	Clear Data Toggle Writing a 1 to this bit clears the DT bit in the USBRXCSRHn register.
6	STALLED	R/W	0	Endpoint Stalled
				Value Description
				0 A STALL handshake has not been transmitted.
				1 A STALL handshake has been transmitted.
				Software must clear this bit.
5	STALL	R/W	0	Send STALL
				Value Description
				0 No effect.
				1 Issues a STALL handshake.
				Software must clear this bit to terminate the STALL condition.
				Note: This bit has no effect where the endpoint is being used for isochronous transfers.

Bit/Field	Name	Type	Reset	Description
4	FLUSH	R/W	0	<p>Flush FIFO</p> <p>Value Description</p> <p>0 No effect.</p> <p>1 Flushes the next packet from the endpoint receive FIFO. The FIFO pointer is reset and the <code>RXRDY</code> bit is cleared.</p> <p>The CPU writes a 1 to this bit to flush the next packet to be read from the endpoint receive FIFO. The FIFO pointer is reset and the <code>RXRDY</code> bit is cleared. Note that if the FIFO is double-buffered, <code>FLUSH</code> may have to be set twice to completely clear the FIFO.</p> <hr/> <p>Important: This bit should only be set when the <code>RXRDY</code> bit is set. At other times, it may cause data to be corrupted.</p> <hr/>
3	DATAERR	RO	0	<p>Data Error</p> <p>Value Description</p> <p>0 Normal operation.</p> <p>1 Indicates that <code>RXRDY</code> is set and the data packet has a CRC or bit-stuff error.</p> <p>This bit is cleared when <code>RXRDY</code> is cleared.</p> <p>Note: This bit is only valid when the endpoint is operating in Isochronous mode. In Bulk mode, it always returns zero.</p>
2	OVER	R/W	0	<p>Overrun</p> <p>Value Description</p> <p>0 No overrun error.</p> <p>1 Indicates that an OUT packet cannot be loaded into the receive FIFO.</p> <p>Software must clear this bit.</p> <p>Note: This bit is only valid when the endpoint is operating in Isochronous mode. In Bulk mode, it always returns zero.</p>
1	FULL	RO	0	<p>FIFO Full</p> <p>Value Description</p> <p>0 The receive FIFO is not full.</p> <p>1 No more packets can be loaded into the receive FIFO.</p>

Bit/Field	Name	Type	Reset	Description
0	RXRDY	R/W	0	Receive Packet Ready
				Value Description
				0 No data packet has been received.
				1 A data packet has been received. The EP _n bit in the USBXIS register is also set in this situation.
				If the AUTOCLR bit in the USBXCSRHn register is set, then the this bit is automatically cleared when a packet of USBXMAXPn bytes has been unloaded from the receive FIFO. If the AUTOCLR bit is clear, or if packets of less than the maximum packet size are unloaded, then software must clear this bit manually when the packet has been unloaded from the receive FIFO.

Register 114: USB Receive Control and Status Endpoint 1 High (USBXCSRH1), offset 0x117

Register 115: USB Receive Control and Status Endpoint 2 High (USBXCSRH2), offset 0x127

Register 116: USB Receive Control and Status Endpoint 3 High (USBXCSRH3), offset 0x137

Register 117: USB Receive Control and Status Endpoint 4 High (USBXCSRH4), offset 0x147

Register 118: USB Receive Control and Status Endpoint 5 High (USBXCSRH5), offset 0x157

Register 119: USB Receive Control and Status Endpoint 6 High (USBXCSRH6), offset 0x167

Register 120: USB Receive Control and Status Endpoint 7 High (USBXCSRH7), offset 0x177

OTG A /
Host

USBXCSRHn is an 8-bit register that provides additional control and status bits for transfers through the currently selected receive endpoint.

OTG B /
Device

OTG A / Host Mode

USB Receive Control and Status Endpoint n High (USBXCSRHn)

Base 0x4005.0000
Offset 0x117
Type R/W, reset 0x00

	7	6	5	4	3	2	1	0
	AUTOCL	AUTORQ	DMAEN	PIDERR	DMAMOD	DTWE	DT	reserved
Type	R/W	R/W	R/W	RO	R/W	RO	RO	RO
Reset	0	0	0	0	0	0	0	0

Bit/Field	Name	Type	Reset	Description
7	AUTOCL	R/W	0	<p>Auto Clear</p> <p>Value Description</p> <p>0 No effect.</p> <p>1 Enables the <code>RXRDY</code> bit to be automatically cleared when a packet of <code>USBRXMAXPn</code> bytes has been unloaded from the receive FIFO. When packets of less than the maximum packet size are unloaded, <code>RXRDY</code> must be cleared manually. Care must be taken when using μDMA to unload the receive FIFO as data is read from the receive FIFO in 4 byte chunks regardless of the value of the <code>MAXLOAD</code> field in the <code>USBRXMAXPn</code> register, see "DMA Operation" on page 1072.</p>
6	AUTORQ	R/W	0	<p>Auto Request</p> <p>Value Description</p> <p>0 No effect.</p> <p>1 Enables the <code>REQPKT</code> bit to be automatically set when the <code>RXRDY</code> bit is cleared.</p> <p>Note: This bit is automatically cleared when a short packet is received.</p>
5	DMAEN	R/W	0	<p>DMA Request Enable</p> <p>Value Description</p> <p>0 Disables the μDMA request for the receive endpoint.</p> <p>1 Enables the μDMA request for the receive endpoint.</p> <p>Note: 3 TX and 3 RX endpoints can be connected to the μDMA module. If this bit is set for a particular endpoint, the <code>DMAARX</code>, <code>DMABRX</code>, or <code>DMACRX</code> field in the USB DMA Select (USBDMASEL) register must be programmed correspondingly.</p>
4	PIDERR	RO	0	<p>PID Error</p> <p>Value Description</p> <p>0 No error.</p> <p>1 Indicates a PID error in the received packet of an isochronous transaction.</p> <p>This bit is ignored in bulk or interrupt transactions.</p>
3	DMAMOD	R/W	0	<p>DMA Request Mode</p> <p>Value Description</p> <p>0 An interrupt is generated after every μDMA packet transfer.</p> <p>1 An interrupt is generated only after the entire μDMA transfer is complete.</p> <p>Note: This bit must not be cleared either before or in the same cycle as the above <code>DMAEN</code> bit is cleared.</p>

Bit/Field	Name	Type	Reset	Description
2	DTWE	RO	0	Data Toggle Write Enable Value Description 0 The DT bit cannot be written. 1 Enables the current state of the receive endpoint data to be written (see DT bit). This bit is automatically cleared once the new value is written.
1	DT	RO	0	Data Toggle When read, this bit indicates the current state of the receive data toggle. If DTWE is High, this bit may be written with the required setting of the data toggle. If DTWE is Low, any value written to this bit is ignored. Care should be taken when writing to this bit as it should only be changed to RESET the receive endpoint.
0	reserved	RO	0	Software should not rely on the value of a reserved bit. To provide compatibility with future products, the value of a reserved bit should be preserved across a read-modify-write operation.

OTG B / Device Mode

USB Receive Control and Status Endpoint n High (USBXRCSRHn)

Base 0x4005.0000
Offset 0x117
Type R/W, reset 0x00

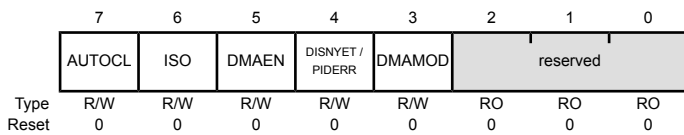

Bit/Field	Name	Type	Reset	Description
7	AUTOCL	R/W	0	Auto Clear Value Description 0 No effect. 1 Enables the RXRDY bit to be automatically cleared when a packet of USBRMAXPn bytes has been unloaded from the receive FIFO. When packets of less than the maximum packet size are unloaded, RXRDY must be cleared manually. Care must be taken when using μDMA to unload the receive FIFO as data is read from the receive FIFO in 4 byte chunks regardless of the value of the MAXLOAD field in the USBRMAXPn register, see “DMA Operation” on page 1072.
6	ISO	R/W	0	Isochronous Transfers Value Description 0 Enables the receive endpoint for isochronous transfers. 1 Enables the receive endpoint for bulk/interrupt transfers.

Bit/Field	Name	Type	Reset	Description
5	DMAEN	R/W	0	<p>DMA Request Enable</p> <p>Value Description</p> <p>0 Disables the μDMA request for the receive endpoint.</p> <p>1 Enables the μDMA request for the receive endpoint.</p> <p>Note: 3 TX and 3 RX endpoints can be connected to the μDMA module. If this bit is set for a particular endpoint, the <i>DMAARX</i>, <i>DMABRX</i>, or <i>DMACRX</i> field in the USB DMA Select (USBDMASEL) register must be programmed correspondingly.</p>
4	DISNYET / PIDERR	R/W	0	<p>Disable NYET / PID Error</p> <p>Value Description</p> <p>0 No effect.</p> <p>1 <i>For bulk or interrupt transactions:</i> Disables the sending of NYET handshakes. When this bit is set, all successfully received packets are acknowledged, including at the point at which the FIFO becomes full.</p> <p><i>For isochronous transactions:</i> Indicates a PID error in the received packet.</p>
3	DMAMOD	R/W	0	<p>DMA Request Mode</p> <p>Value Description</p> <p>0 An interrupt is generated after every μDMA packet transfer.</p> <p>1 An interrupt is generated only after the entire μDMA transfer is complete.</p> <p>Note: This bit must not be cleared either before or in the same cycle as the above <i>DMAEN</i> bit is cleared.</p>
2:0	reserved	RO	0x0	Software should not rely on the value of a reserved bit. To provide compatibility with future products, the value of a reserved bit should be preserved across a read-modify-write operation.

Register 121: USB Receive Byte Count Endpoint 1 (USBRXCOUNT1), offset 0x118

Register 122: USB Receive Byte Count Endpoint 2 (USBRXCOUNT2), offset 0x128

Register 123: USB Receive Byte Count Endpoint 3 (USBRXCOUNT3), offset 0x138

Register 124: USB Receive Byte Count Endpoint 4 (USBRXCOUNT4), offset 0x148

Register 125: USB Receive Byte Count Endpoint 5 (USBRXCOUNT5), offset 0x158

Register 126: USB Receive Byte Count Endpoint 6 (USBRXCOUNT6), offset 0x168

Register 127: USB Receive Byte Count Endpoint 7 (USBRXCOUNT7), offset 0x178

OTG A / Host

Note: The value returned changes as the FIFO is unloaded and is only valid while the `RXRDY` bit in the `USBXCSSLn` register is set.

OTG B / Device

USBXCOUNTn is a 16-bit read-only register that holds the number of data bytes in the packet currently in line to be read from the receive FIFO. If the packet is transmitted as multiple bulk packets, the number given is for the combined packet.

USB Receive Byte Count Endpoint n (`USBXCOUNTn`)

Base 0x4005.0000

Offset 0x118

Type RO, reset 0x0000

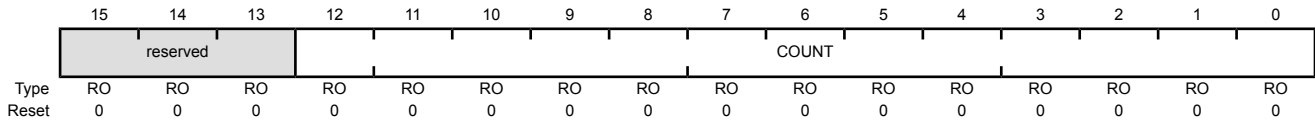

Bit/Field	Name	Type	Reset	Description
15:13	reserved	RO	0x0	Software should not rely on the value of a reserved bit. To provide compatibility with future products, the value of a reserved bit should be preserved across a read-modify-write operation.
12:0	COUNT	RO	0x000	Receive Packet Count Indicates the number of bytes in the receive packet.

Register 128: USB Host Transmit Configure Type Endpoint 1 (USBTXTYPE1), offset 0x11A

Register 129: USB Host Transmit Configure Type Endpoint 2 (USBTXTYPE2), offset 0x12A

Register 130: USB Host Transmit Configure Type Endpoint 3 (USBTXTYPE3), offset 0x13A

Register 131: USB Host Transmit Configure Type Endpoint 4 (USBTXTYPE4), offset 0x14A

Register 132: USB Host Transmit Configure Type Endpoint 5 (USBTXTYPE5), offset 0x15A

Register 133: USB Host Transmit Configure Type Endpoint 6 (USBTXTYPE6), offset 0x16A

Register 134: USB Host Transmit Configure Type Endpoint 7 (USBTXTYPE7), offset 0x17A

**OTG A /
Host**

USBTXTYPE_n is an 8-bit register that must be written with the endpoint number to be targeted by the endpoint, the transaction protocol to use for the currently selected transmit endpoint, and its operating speed.

USB Host Transmit Configure Type Endpoint n (USBTXTYPE_n)

Base 0x4005.0000
Offset 0x11A
Type R/W, reset 0x00

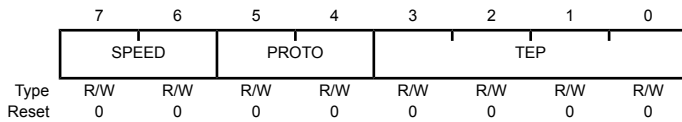

Bit/Field	Name	Type	Reset	Description
-----------	------	------	-------	-------------

7:6	SPEED	R/W	0x0	Operating Speed
-----	-------	-----	-----	-----------------

This bit field specifies the operating speed of the target Device:

Value	Description
-------	-------------

0x0	Default
-----	---------

The target is assumed to be using the same connection speed as the USB controller.

0x1	Reserved
-----	----------

0x2	Full
-----	------

0x3	Low
-----	-----

Bit/Field	Name	Type	Reset	Description
5:4	PROTO	R/W	0x0	Protocol Software must configure this bit field to select the required protocol for the transmit endpoint: Value Description 0x0 Control 0x1 Isochronous 0x2 Bulk 0x3 Interrupt
3:0	TEP	R/W	0x0	Target Endpoint Number Software must configure this value to the endpoint number contained in the transmit endpoint descriptor returned to the USB controller during Device enumeration.

Register 135: USB Host Transmit Interval Endpoint 1 (USBTXINTERVAL1), offset 0x11B

Register 136: USB Host Transmit Interval Endpoint 2 (USBTXINTERVAL2), offset 0x12B

Register 137: USB Host Transmit Interval Endpoint 3 (USBTXINTERVAL3), offset 0x13B

Register 138: USB Host Transmit Interval Endpoint 4 (USBTXINTERVAL4), offset 0x14B

Register 139: USB Host Transmit Interval Endpoint 5 (USBTXINTERVAL5), offset 0x15B

Register 140: USB Host Transmit Interval Endpoint 6 (USBTXINTERVAL6), offset 0x16B

Register 141: USB Host Transmit Interval Endpoint 7 (USBTXINTERVAL7), offset 0x17B

OTG A /
Host

USBTXINTERVAL_n is an 8-bit register that, for interrupt and isochronous transfers, defines the polling interval for the currently selected transmit endpoint. For bulk endpoints, this register defines the number of frames after which the endpoint should time out on receiving a stream of NAK responses.

The **USBTXINTERVAL_n** register value defines a number of frames, as follows:

Transfer Type	Speed	Valid values (m)	Interpretation
Interrupt	Low-Speed or Full-Speed	0x01 – 0xFF	The polling interval is m frames.
Isochronous	Full-Speed	0x01 – 0x10	The polling interval is $2^{(m-1)}$ frames.
Bulk	Full-Speed	0x02 – 0x10	The NAK Limit is $2^{(m-1)}$ frames. A value of 0 or 1 disables the NAK timeout function.

USB Host Transmit Interval Endpoint n (USBTXINTERVAL_n)

Base 0x4005.0000
Offset 0x11B
Type R/W, reset 0x00

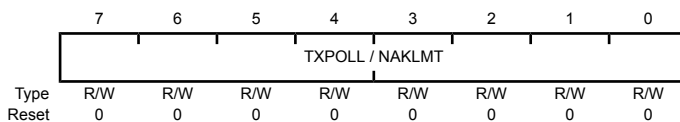

Bit/Field	Name	Type	Reset	Description
7:0	TXPOLL / NAKLMT	R/W	0x00	TX Polling / NAK Limit The polling interval for interrupt/isochronous transfers; the NAK limit for bulk transfers. See table above for valid entries; other values are reserved.

Register 142: USB Host Configure Receive Type Endpoint 1 (USBRXTYPE1), offset 0x11C

Register 143: USB Host Configure Receive Type Endpoint 2 (USBRXTYPE2), offset 0x12C

Register 144: USB Host Configure Receive Type Endpoint 3 (USBRXTYPE3), offset 0x13C

Register 145: USB Host Configure Receive Type Endpoint 4 (USBRXTYPE4), offset 0x14C

Register 146: USB Host Configure Receive Type Endpoint 5 (USBRXTYPE5), offset 0x15C

Register 147: USB Host Configure Receive Type Endpoint 6 (USBRXTYPE6), offset 0x16C

Register 148: USB Host Configure Receive Type Endpoint 7 (USBRXTYPE7), offset 0x17C

**OTG A /
Host**

USBRXTYPE_n is an 8-bit register that must be written with the endpoint number to be targeted by the endpoint, the transaction protocol to use for the currently selected receive endpoint, and its operating speed.

USB Host Configure Receive Type Endpoint n (USBRXTYPE_n)

Base 0x4005.0000
Offset 0x11C
Type R/W, reset 0x00

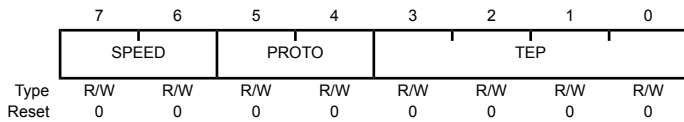

Bit/Field	Name	Type	Reset	Description
7:6	SPEED	R/W	0x0	Operating Speed

This bit field specifies the operating speed of the target Device:

Value	Description
0x0	Default
0x1	Reserved
0x2	Full
0x3	Low

The target is assumed to be using the same connection speed as the USB controller.

Bit/Field	Name	Type	Reset	Description
5:4	PROTO	R/W	0x0	Protocol Software must configure this bit field to select the required protocol for the receive endpoint: Value Description 0x0 Control 0x1 Isochronous 0x2 Bulk 0x3 Interrupt
3:0	TEP	R/W	0x0	Target Endpoint Number Software must set this value to the endpoint number contained in the receive endpoint descriptor returned to the USB controller during Device enumeration.

Register 149: USB Host Receive Polling Interval Endpoint 1 (USBRXINTERVAL1), offset 0x11D

Register 150: USB Host Receive Polling Interval Endpoint 2 (USBRXINTERVAL2), offset 0x12D

Register 151: USB Host Receive Polling Interval Endpoint 3 (USBRXINTERVAL3), offset 0x13D

Register 152: USB Host Receive Polling Interval Endpoint 4 (USBRXINTERVAL4), offset 0x14D

Register 153: USB Host Receive Polling Interval Endpoint 5 (USBRXINTERVAL5), offset 0x15D

Register 154: USB Host Receive Polling Interval Endpoint 6 (USBRXINTERVAL6), offset 0x16D

Register 155: USB Host Receive Polling Interval Endpoint 7 (USBRXINTERVAL7), offset 0x17D

OTG A / Host

USBRXINTERVAL_n is an 8-bit register that, for interrupt and isochronous transfers, defines the polling interval for the currently selected receive endpoint. For bulk endpoints, this register defines the number of frames after which the endpoint should time out on receiving a stream of NAK responses.

The USBRXINTERVAL_n register value defines a number of frames, as follows:

Transfer Type	Speed	Valid values (m)	Interpretation
Interrupt	Low-Speed or Full-Speed	0x01 – 0xFF	The polling interval is <i>m</i> frames.
Isochronous	Full-Speed	0x01 – 0x10	The polling interval is 2 ^(<i>m</i>-1) frames.
Bulk	Full-Speed	0x02 – 0x10	The NAK Limit is 2 ^(<i>m</i>-1) frames. A value of 0 or 1 disables the NAK timeout function.

USB Host Receive Polling Interval Endpoint n (USBRXINTERVAL_n)

Base 0x4005.0000
 Offset 0x11D
 Type R/W, reset 0x00

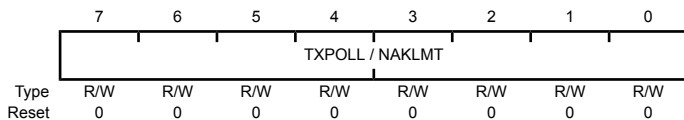

Bit/Field	Name	Type	Reset	Description
7:0	TXPOLL / NAKLMT	R/W	0x00	RX Polling / NAK Limit The polling interval for interrupt/isochronous transfers; the NAK limit for bulk transfers. See table above for valid entries; other values are reserved.

Register 156: USB Request Packet Count in Block Transfer Endpoint 1 (USBRQPKTCOUNT1), offset 0x304

Register 157: USB Request Packet Count in Block Transfer Endpoint 2 (USBRQPKTCOUNT2), offset 0x308

Register 158: USB Request Packet Count in Block Transfer Endpoint 3 (USBRQPKTCOUNT3), offset 0x30C

Register 159: USB Request Packet Count in Block Transfer Endpoint 4 (USBRQPKTCOUNT4), offset 0x310

Register 160: USB Request Packet Count in Block Transfer Endpoint 5 (USBRQPKTCOUNT5), offset 0x314

Register 161: USB Request Packet Count in Block Transfer Endpoint 6 (USBRQPKTCOUNT6), offset 0x318

Register 162: USB Request Packet Count in Block Transfer Endpoint 7 (USBRQPKTCOUNT7), offset 0x31C

**OTG A /
Host**

This 16-bit read/write register is used in Host mode to specify the number of packets that are to be transferred in a block transfer of one or more bulk packets to receive endpoint n. The USB controller uses the value recorded in this register to determine the number of requests to issue where the `AUTORQ` bit in the `USBRXCSRHn` register has been set. See "IN Transactions as a Host" on page 1068.

Note: Multiple packets combined into a single bulk packet within the FIFO count as one packet.

USB Request Packet Count in Block Transfer Endpoint n (USBRQPKTCOUNTn)

Base 0x4005.0000
Offset 0x304
Type R/W, reset 0x0000

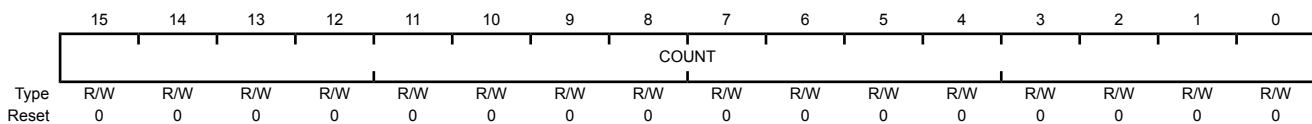

Bit/Field	Name	Type	Reset	Description
15:0	COUNT	R/W	0x0000	Block Transfer Packet Count Sets the number of packets of the size defined by the <code>MAXLOAD</code> bit field that are to be transferred in a block transfer.
Note:				This is only used in Host mode when <code>AUTORQ</code> is set. The bit has no effect in Device mode or when <code>AUTORQ</code> is not set.

Register 163: USB Receive Double Packet Buffer Disable (USBRXDPKTBUFDIS), offset 0x340

OTG A / Host

USBRXDPKTBUFDIS is a 16-bit register that indicates which of the receive endpoints have disabled the double-packet buffer functionality (see the section called “Double-Packet Buffering” on page 1064).

OTG B / Device

USB Receive Double Packet Buffer Disable (USBRXDPKTBUFDIS)

Base 0x4005.0000
 Offset 0x340
 Type R/W, reset 0x0000

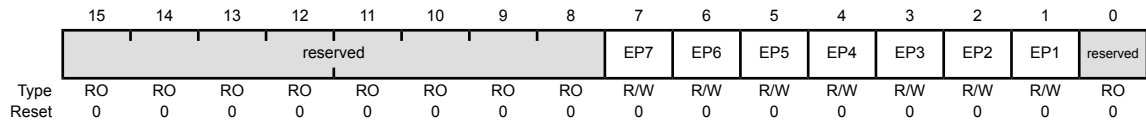

Bit/Field	Name	Type	Reset	Description
15:8	reserved	RO	0	Software should not rely on the value of a reserved bit. To provide compatibility with future products, the value of a reserved bit should be preserved across a read-modify-write operation.
7	EP7	R/W	0	EP7 RX Double-Packet Buffer Disable Value Description 0 Disables double-packet buffering. 1 Enables double-packet buffering.
6	EP6	R/W	0	EP6 RX Double-Packet Buffer Disable Same description as EP7.
5	EP5	R/W	0	EP5 RX Double-Packet Buffer Disable Same description as EP7.
4	EP4	R/W	0	EP4 RX Double-Packet Buffer Disable Same description as EP7.
3	EP3	R/W	0	EP3 RX Double-Packet Buffer Disable Same description as EP7.
2	EP2	R/W	0	EP2 RX Double-Packet Buffer Disable Same description as EP7.
1	EP1	R/W	0	EP1 RX Double-Packet Buffer Disable Same description as EP7.
0	reserved	RO	0	Software should not rely on the value of a reserved bit. To provide compatibility with future products, the value of a reserved bit should be preserved across a read-modify-write operation.

Register 164: USB Transmit Double Packet Buffer Disable (USBTXDPKTBUFDIS), offset 0x342

OTG A /
Host

USBTXDPKTBUFDIS is a 16-bit register that indicates which of the transmit endpoints have disabled the double-packet buffer functionality (see the section called “Double-Packet Buffering” on page 1063).

USB Transmit Double Packet Buffer Disable (USBTXDPKTBUFDIS)

OTG B /
Device

Base 0x4005.0000
Offset 0x342
Type R/W, reset 0x0000

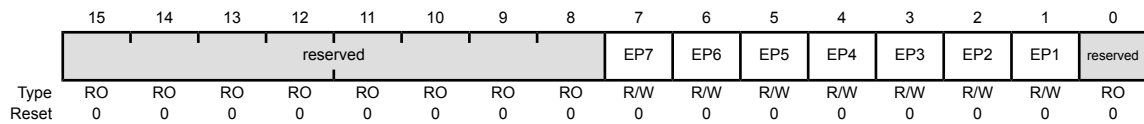

Bit/Field	Name	Type	Reset	Description
15:8	reserved	RO	0	Software should not rely on the value of a reserved bit. To provide compatibility with future products, the value of a reserved bit should be preserved across a read-modify-write operation.
7	EP7	R/W	0	EP7 TX Double-Packet Buffer Disable Value Description 0 Disables double-packet buffering. 1 Enables double-packet buffering.
6	EP6	R/W	0	EP6 TX Double-Packet Buffer Disable Same description as EP7.
5	EP5	R/W	0	EP5 TX Double-Packet Buffer Disable Same description as EP7.
4	EP4	R/W	0	EP4 TX Double-Packet Buffer Disable Same description as EP7.
3	EP3	R/W	0	EP3 TX Double-Packet Buffer Disable Same description as EP7.
2	EP2	R/W	0	EP2 TX Double-Packet Buffer Disable Same description as EP7.
1	EP1	R/W	0	EP1 TX Double-Packet Buffer Disable Same description as EP7.
0	reserved	RO	0	Software should not rely on the value of a reserved bit. To provide compatibility with future products, the value of a reserved bit should be preserved across a read-modify-write operation.

Register 165: USB External Power Control (USBEPEN), offset 0x400

OTG A / Host

This 32-bit register specifies the function of the two-pin external power interface (USB0EPEN and USB0PFLT). The assertion of the power fault input may generate an automatic action, as controlled by the hardware configuration registers. The automatic action is necessary because the fault condition may require a response faster than one provided by firmware.

OTG B / Device

USB External Power Control (USBEPEN)

Base 0x4005.0000
Offset 0x400
Type R/W, reset 0x0000.0000

	31	30	29	28	27	26	25	24	23	22	21	20	19	18	17	16
	reserved															
Type	RO	RO	RO	RO	RO	RO	RO	RO	RO	RO	RO	RO	RO	RO	RO	RO
Reset	0	0	0	0	0	0	0	0	0	0	0	0	0	0	0	0
	15	14	13	12	11	10	9	8	7	6	5	4	3	2	1	0
	reserved						PFLTACT	reserved	PFLTAEN	PFLTSEN	PFLTEN	reserved	EPENDE	EPEN		
Type	RO	RO	RO	RO	RO	RO	R/W	R/W	RO	R/W	R/W	R/W	RO	R/W	R/W	R/W
Reset	0	0	0	0	0	0	0	0	0	0	0	0	0	0	0	0

Bit/Field	Name	Type	Reset	Description										
31:10	reserved	RO	0x0000.0	Software should not rely on the value of a reserved bit. To provide compatibility with future products, the value of a reserved bit should be preserved across a read-modify-write operation.										
9:8	PFLTACT	R/W	0x0	<p>Power Fault Action</p> <p>This bit field specifies how the USB0EPEN signal is changed when detecting a USB power fault.</p> <table border="0"> <tr> <td>Value</td> <td>Description</td> </tr> <tr> <td>0x0</td> <td> <p>Unchanged</p> <p>USB0EPEN is controlled by the combination of the EPEN and EPENDE bits.</p> </td> </tr> <tr> <td>0x1</td> <td> <p>Tristate</p> <p>USB0EPEN is undriven (tristate).</p> </td> </tr> <tr> <td>0x2</td> <td> <p>Low</p> <p>USB0EPEN is driven Low.</p> </td> </tr> <tr> <td>0x3</td> <td> <p>High</p> <p>USB0EPEN is driven High.</p> </td> </tr> </table>	Value	Description	0x0	<p>Unchanged</p> <p>USB0EPEN is controlled by the combination of the EPEN and EPENDE bits.</p>	0x1	<p>Tristate</p> <p>USB0EPEN is undriven (tristate).</p>	0x2	<p>Low</p> <p>USB0EPEN is driven Low.</p>	0x3	<p>High</p> <p>USB0EPEN is driven High.</p>
Value	Description													
0x0	<p>Unchanged</p> <p>USB0EPEN is controlled by the combination of the EPEN and EPENDE bits.</p>													
0x1	<p>Tristate</p> <p>USB0EPEN is undriven (tristate).</p>													
0x2	<p>Low</p> <p>USB0EPEN is driven Low.</p>													
0x3	<p>High</p> <p>USB0EPEN is driven High.</p>													
7	reserved	RO	0	Software should not rely on the value of a reserved bit. To provide compatibility with future products, the value of a reserved bit should be preserved across a read-modify-write operation.										

Bit/Field	Name	Type	Reset	Description
6	PFLTAEN	R/W	0	<p>Power Fault Action Enable</p> <p>This bit specifies whether a USB power fault triggers any automatic corrective action regarding the driven state of the USB0EPEN signal.</p> <p>Value Description</p> <p>0 Disabled</p> <p>USB0EPEN is controlled by the combination of the EPEN and EPENDE bits.</p> <p>1 Enabled</p> <p>The USB0EPEN output is automatically changed to the state specified by the PFLTACT field.</p>
5	PFLTSEN	R/W	0	<p>Power Fault Sense</p> <p>This bit specifies the logical sense of the USB0PFLT input signal that indicates an error condition.</p> <p>The complementary state is the inactive state.</p> <p>Value Description</p> <p>0 Low Fault</p> <p>If USB0PFLT is driven Low, the power fault is signaled internally (if enabled by the PFLTEN bit).</p> <p>1 High Fault</p> <p>If USB0PFLT is driven High, the power fault is signaled internally (if enabled by the PFLTEN bit).</p>
4	PFLTEN	R/W	0	<p>Power Fault Input Enable</p> <p>This bit specifies whether the USB0PFLT input signal is used in internal logic.</p> <p>Value Description</p> <p>0 Not Used</p> <p>The USB0PFLT signal is ignored.</p> <p>1 Used</p> <p>The USB0PFLT signal is used internally.</p>
3	reserved	RO	0	<p>Software should not rely on the value of a reserved bit. To provide compatibility with future products, the value of a reserved bit should be preserved across a read-modify-write operation.</p>

Bit/Field	Name	Type	Reset	Description
2	EPENDE	R/W	0	<p>EPEN Drive Enable</p> <p>This bit specifies whether the <code>USB0EPEN</code> signal is driven or undriven (tristate). When driven, the signal value is specified by the <code>EPEN</code> field. When not driven, the <code>EPEN</code> field is ignored and the <code>USB0EPEN</code> signal is placed in a high-impedance state.</p> <p>Value Description</p> <p>0 Not Driven The <code>USB0EPEN</code> signal is high impedance.</p> <p>1 Driven The <code>USB0EPEN</code> signal is driven to the logical value specified by the value of the <code>EPEN</code> field.</p> <p>The <code>USB0EPEN</code> signal is undriven at reset because the sense of the external power supply enable is unknown. By adding the high-impedance state, system designers may bias the power supply enable to the disabled state using a large resistor (100 kΩ) and later configure and drive the output signal to enable the power supply.</p>
1:0	EPEN	R/W	0x0	<p>External Power Supply Enable Configuration</p> <p>This bit field specifies and controls the logical value driven on the <code>USB0EPEN</code> signal.</p> <p>Value Description</p> <p>0x0 Power Enable Active Low The <code>USB0EPEN</code> signal is driven Low if the <code>EPENDE</code> bit is set.</p> <p>0x1 Power Enable Active High The <code>USB0EPEN</code> signal is driven High if the <code>EPENDE</code> bit is set.</p> <p>0x2 Power Enable High if VBUS Low The <code>USB0EPEN</code> signal is driven High when the A device is not recognized.</p> <p>0x3 Power Enable High if VBUS High The <code>USB0EPEN</code> signal is driven High when the A device is recognized.</p>

Register 166: USB External Power Control Raw Interrupt Status (USBEPCRIS), offset 0x404

OTG A /
Host

This 32-bit register specifies the unmasked interrupt status of the two-pin external power interface.

USB External Power Control Raw Interrupt Status (USBEPCRIS)

Base 0x4005.0000

Offset 0x404

Type RO, reset 0x0000.0000

OTG B /
Device

	31	30	29	28	27	26	25	24	23	22	21	20	19	18	17	16
	reserved															
Type	RO	RO	RO	RO	RO	RO	RO	RO	RO	RO	RO	RO	RO	RO	RO	RO
Reset	0	0	0	0	0	0	0	0	0	0	0	0	0	0	0	0
	15	14	13	12	11	10	9	8	7	6	5	4	3	2	1	0
	reserved															PF
Type	RO	RO	RO	RO	RO	RO	RO	RO	RO	RO	RO	RO	RO	RO	RO	RO
Reset	0	0	0	0	0	0	0	0	0	0	0	0	0	0	0	0

Bit/Field	Name	Type	Reset	Description
31:1	reserved	RO	0x0000.000	Software should not rely on the value of a reserved bit. To provide compatibility with future products, the value of a reserved bit should be preserved across a read-modify-write operation.

0	PF	RO	0	USB Power Fault Interrupt Status
---	----	----	---	----------------------------------

Value Description

1 A Power Fault status has been detected.

0 An interrupt has not occurred.

This bit is cleared by writing a 1 to the PF bit in the **USBEPDISC** register.

Register 167: USB External Power Control Interrupt Mask (USBEPICIM), offset 0x408

OTG A /
Host

This 32-bit register specifies the interrupt mask of the two-pin external power interface.

USB External Power Control Interrupt Mask (USBEPICIM)

Base 0x4005.0000

Offset 0x408

Type R/W, reset 0x0000.0000

OTG B /
Device

	31	30	29	28	27	26	25	24	23	22	21	20	19	18	17	16
	reserved															
Type	RO	RO	RO	RO	RO	RO	RO	RO	RO	RO	RO	RO	RO	RO	RO	RO
Reset	0	0	0	0	0	0	0	0	0	0	0	0	0	0	0	0
	15	14	13	12	11	10	9	8	7	6	5	4	3	2	1	0
	reserved															PF
Type	RO	RO	RO	RO	RO	RO	RO	RO	RO	RO	RO	RO	RO	RO	RO	R/W
Reset	0	0	0	0	0	0	0	0	0	0	0	0	0	0	0	0

Bit/Field	Name	Type	Reset	Description
31:1	reserved	RO	0x0000.000	Software should not rely on the value of a reserved bit. To provide compatibility with future products, the value of a reserved bit should be preserved across a read-modify-write operation.
0	PF	R/W	0	USB Power Fault Interrupt Mask
				Value Description
				1 The raw interrupt signal from a detected power fault is sent to the interrupt controller.
				0 A detected power fault does not affect the interrupt status.

Register 168: USB External Power Control Interrupt Status and Clear (USBEPICISC), offset 0x40C

OTG A /
Host

This 32-bit register specifies the masked interrupt status of the two-pin external power interface. It also provides a method to clear the interrupt state.

OTG B /
Device

USB External Power Control Interrupt Status and Clear (USBEPICISC)

Base 0x4005.0000
Offset 0x40C
Type R/W, reset 0x0000.0000

	31	30	29	28	27	26	25	24	23	22	21	20	19	18	17	16
	reserved															
Type	RO	RO	RO	RO	RO	RO	RO	RO	RO	RO	RO	RO	RO	RO	RO	RO
Reset	0	0	0	0	0	0	0	0	0	0	0	0	0	0	0	0
	15	14	13	12	11	10	9	8	7	6	5	4	3	2	1	0
	reserved															PF
Type	RO	RO	RO	RO	RO	RO	RO	RO	RO	RO	RO	RO	RO	RO	RO	R/W1C
Reset	0	0	0	0	0	0	0	0	0	0	0	0	0	0	0	0

Bit/Field	Name	Type	Reset	Description
31:1	reserved	RO	0x0000.000	Software should not rely on the value of a reserved bit. To provide compatibility with future products, the value of a reserved bit should be preserved across a read-modify-write operation.
0	PF	R/W1C	0	USB Power Fault Interrupt Status and Clear

Value Description

- 1 The **PF** bits in the **USBEPICRIS** and **USBEPICIM** registers are set, providing an interrupt to the interrupt controller.
- 0 No interrupt has occurred or the interrupt is masked.

This bit is cleared by writing a 1. Clearing this bit also clears the **PF** bit in the **USBEPICRIS** register.

Register 169: USB Device RESUME Raw Interrupt Status (USBDRRIS), offset 0x410

OTG A /
Host

The **USBDRRIS** 32-bit register is the raw interrupt status register. On a read, this register gives the current raw status value of the corresponding interrupt prior to masking. A write has no effect.

OTG B /
Device

USB Device RESUME Raw Interrupt Status (USBDRRIS)

Base 0x4005.0000
Offset 0x410
Type RO, reset 0x0000.0000

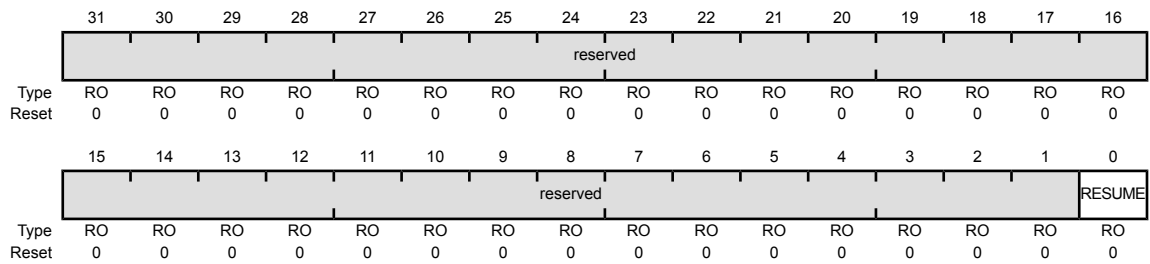

Bit/Field	Name	Type	Reset	Description
31:1	reserved	RO	0x0000.000	Software should not rely on the value of a reserved bit. To provide compatibility with future products, the value of a reserved bit should be preserved across a read-modify-write operation.
0	RESUME	RO	0	RESUME Interrupt Status
				Value Description
				1 A RESUME status has been detected.
				0 An interrupt has not occurred.
				This bit is cleared by writing a 1 to the RESUME bit in the USBDRISC register.

Register 170: USB Device RESUME Interrupt Mask (USBDRIM), offset 0x414**OTG A /
Host**

The **USBDRIM** 32-bit register is the masked interrupt status register. On a read, this register gives the current value of the mask on the corresponding interrupt. Setting a bit sets the mask, preventing the interrupt from being signaled to the interrupt controller. Clearing a bit clears the corresponding mask, enabling the interrupt to be sent to the interrupt controller.

**OTG B /
Device**

USB Device RESUME Interrupt Mask (USBDRIM)

Base 0x4005.0000

Offset 0x414

Type R/W, reset 0x0000.0000

	31	30	29	28	27	26	25	24	23	22	21	20	19	18	17	16
	reserved															
Type	RO	RO	RO	RO	RO	RO	RO	RO	RO	RO	RO	RO	RO	RO	RO	RO
Reset	0	0	0	0	0	0	0	0	0	0	0	0	0	0	0	0
	15	14	13	12	11	10	9	8	7	6	5	4	3	2	1	0
	reserved															RESUME
Type	RO	RO	RO	RO	RO	RO	RO	RO	RO	RO	RO	RO	RO	RO	RO	R/W
Reset	0	0	0	0	0	0	0	0	0	0	0	0	0	0	0	0

Bit/Field	Name	Type	Reset	Description
31:1	reserved	RO	0x00	Software should not rely on the value of a reserved bit. To provide compatibility with future products, the value of a reserved bit should be preserved across a read-modify-write operation.
0	RESUME	R/W	0	RESUME Interrupt Mask

Value Description

- | | |
|---|---|
| 1 | The raw interrupt signal from a detected RESUME is sent to the interrupt controller. This bit should only be set when a SUSPEND has been detected (the SUSPEND bit in the USBIS register is set). |
| 0 | A detected RESUME does not affect the interrupt status. |

Register 171: USB Device RESUME Interrupt Status and Clear (USBDRISC), offset 0x418

OTG A /
Host

The **USBDRISC** 32-bit register is the interrupt clear register. On a write of 1, the corresponding interrupt is cleared. A write of 0 has no effect.

OTG B /
Device

USB Device RESUME Interrupt Status and Clear (USBDRISC)

Base 0x4005.0000
Offset 0x418
Type W1C, reset 0x0000.0000

	31	30	29	28	27	26	25	24	23	22	21	20	19	18	17	16
	reserved															
Type	RO	RO	RO	RO	RO	RO	RO	RO	RO	RO	RO	RO	RO	RO	RO	RO
Reset	0	0	0	0	0	0	0	0	0	0	0	0	0	0	0	0
	15	14	13	12	11	10	9	8	7	6	5	4	3	2	1	0
	reserved															RESUME
Type	RO	RO	RO	RO	RO	RO	RO	RO	RO	RO	RO	RO	RO	RO	RO	R/W1C
Reset	0	0	0	0	0	0	0	0	0	0	0	0	0	0	0	0

Bit/Field	Name	Type	Reset	Description
31:1	reserved	RO	0x0000.000	Software should not rely on the value of a reserved bit. To provide compatibility with future products, the value of a reserved bit should be preserved across a read-modify-write operation.
0	RESUME	R/W1C	0	RESUME Interrupt Status and Clear
				Value Description
				1 The RESUME bits in the USBDRRIS and USBDRCIM registers are set, providing an interrupt to the interrupt controller.
				0 No interrupt has occurred or the interrupt is masked.
				This bit is cleared by writing a 1. Clearing this bit also clears the RESUME bit in the USBDRCRIS register.

Register 172: USB General-Purpose Control and Status (USBGPCS), offset 0x41C

OTG A /
Host

USBGPCS provides the state of the internal ID signal.

OTG B /
Device

Note: When used in OTG mode, USB0VBUS and USB0ID do not require any configuration as they are dedicated pins for the USB controller and directly connect to the USB connector's VBUS and ID signals. If the USB controller is used as either a dedicated Host or Device, the DEVMODOTG and DEVMOD bits in the **USB General-Purpose Control and Status (USBGPCS)** register can be used to connect the USB0VBUS and USB0ID inputs to fixed levels internally, freeing the PB0 and PB1 pins for GPIO use. For proper self-powered Device operation, the VBUS value must still be monitored to assure that if the Host removes VBUS, the self-powered Device disables the D+/D- pull-up resistors. This function can be accomplished by connecting a standard GPIO to VBUS.

USB General-Purpose Control and Status (USBGPCS)

Base 0x4005.0000
Offset 0x41C
Type R/W, reset 0x0000.0003

	31	30	29	28	27	26	25	24	23	22	21	20	19	18	17	16
	reserved															
Type	RO	RO	RO	RO	RO	RO	RO	RO	RO	RO	RO	RO	RO	RO	RO	RO
Reset	0	0	0	0	0	0	0	0	0	0	0	0	0	0	0	0
	15	14	13	12	11	10	9	8	7	6	5	4	3	2	1	0
	reserved														DEVMODOTG	DEVMOD
Type	RO	RO	RO	RO	RO	RO	RO	RO	RO	RO	RO	RO	RO	RO	R/W	R/W
Reset	0	0	0	0	0	0	0	0	0	0	0	0	0	0	1	1

Bit/Field	Name	Type	Reset	Description				
31:2	reserved	RO	0x0000.000	Software should not rely on the value of a reserved bit. To provide compatibility with future products, the value of a reserved bit should be preserved across a read-modify-write operation.				
1	DEVMODOTG	R/W	1	<p>Enable Device Mode</p> <p>This bit enables the DEVMOD bit to control the state of the internal ID signal in OTG mode.</p> <p>Value Description</p> <table border="0"> <tr> <td>0</td> <td>The mode is specified by the state of the internal ID signal.</td> </tr> <tr> <td>1</td> <td>This bit enables the DEVMOD bit to control the internal ID signal.</td> </tr> </table>	0	The mode is specified by the state of the internal ID signal.	1	This bit enables the DEVMOD bit to control the internal ID signal.
0	The mode is specified by the state of the internal ID signal.							
1	This bit enables the DEVMOD bit to control the internal ID signal.							
0	DEVMOD	R/W	1	<p>Device Mode</p> <p>This bit specifies the state of the internal ID signal in Host mode and in OTG mode when the DEVMODOTG bit is set.</p> <p>In Device mode this bit is ignored (assumed set).</p> <p>Value Description</p> <table border="0"> <tr> <td>0</td> <td>Host mode</td> </tr> <tr> <td>1</td> <td>Device mode</td> </tr> </table>	0	Host mode	1	Device mode
0	Host mode							
1	Device mode							

Register 173: USB VBUS Droop Control (USBVDC), offset 0x430

OTG A /
Host

This 32-bit register enables a controlled masking of VBUS to compensate for any in-rush current by a Device that is connected to the Host controller. The in-rush current can cause VBUS to droop, causing the USB controller's behavior to be unexpected. The USB Host controller allows VBUS to fall lower than the VBUS Valid level (4.75 V) but not below AValid (2.0 V) for 65 microseconds without signaling a `VBUSERR` interrupt in the controller. Without this, any glitch on VBUS would force the USB Host controller to remove power from VBUS and then re-enumerate the Device.

USB VBUS Droop Control (USBVDC)

Base 0x4005.0000
Offset 0x430
Type R/W, reset 0x0000.0000

	31	30	29	28	27	26	25	24	23	22	21	20	19	18	17	16
	reserved															
Type	RO	RO	RO	RO	RO	RO	RO	RO	RO	RO	RO	RO	RO	RO	RO	RO
Reset	0	0	0	0	0	0	0	0	0	0	0	0	0	0	0	0
	15	14	13	12	11	10	9	8	7	6	5	4	3	2	1	0
	reserved															VBDEN
Type	RO	RO	RO	RO	RO	RO	RO	RO	RO	RO	RO	RO	RO	RO	RO	R/W
Reset	0	0	0	0	0	0	0	0	0	0	0	0	0	0	0	0

Bit/Field	Name	Type	Reset	Description
31:1	reserved	RO	0x0000.0000	Software should not rely on the value of a reserved bit. To provide compatibility with future products, the value of a reserved bit should be preserved across a read-modify-write operation.
0	VBDEN	R/W	0	VBUS Droop Enable
				Value Description
			0	No effect.
			1	Any changes from VBUSVALID are masked when VBUS goes below 4.75 V but not lower than 2.0 V for 65 microseconds. During this time, the VBUS state indicates VBUSVALID.

Register 174: USB VBUS Droop Control Raw Interrupt Status (USBVDCRIS), offset 0x434

OTG A /
Host

This 32-bit register specifies the unmasked interrupt status of the VBUS droop limit of 65 microseconds.

USB VBUS Droop Control Raw Interrupt Status (USBVDCRIS)

Base 0x4005.0000

Offset 0x434

Type RO, reset 0x0000.0000

	31	30	29	28	27	26	25	24	23	22	21	20	19	18	17	16
	reserved															
Type	RO	RO	RO	RO	RO	RO	RO	RO	RO	RO	RO	RO	RO	RO	RO	RO
Reset	0	0	0	0	0	0	0	0	0	0	0	0	0	0	0	0
	15	14	13	12	11	10	9	8	7	6	5	4	3	2	1	0
	reserved															VD
Type	RO	RO	RO	RO	RO	RO	RO	RO	RO	RO	RO	RO	RO	RO	RO	RO
Reset	0	0	0	0	0	0	0	0	0	0	0	0	0	0	0	0

Bit/Field	Name	Type	Reset	Description
31:1	reserved	RO	0x0000.000	Software should not rely on the value of a reserved bit. To provide compatibility with future products, the value of a reserved bit should be preserved across a read-modify-write operation.
0	VD	RO	0	VBUS Droop Raw Interrupt Status

Value Description

1	A VBUS droop lasting for 65 microseconds has been detected.
0	An interrupt has not occurred.

This bit is cleared by writing a 1 to the VD bit in the **USBVDCISC** register.

Register 175: USB VBUS Droop Control Interrupt Mask (USBVDCIM), offset 0x438

**OTG A /
Host**

This 32-bit register specifies the interrupt mask of the VBUS droop.

USB VBUS Droop Control Interrupt Mask (USBVDCIM)

Base 0x4005.0000

Offset 0x438

Type R/W, reset 0x0000.0000

	31	30	29	28	27	26	25	24	23	22	21	20	19	18	17	16
	reserved															
Type	RO	RO	RO	RO	RO	RO	RO	RO	RO	RO	RO	RO	RO	RO	RO	RO
Reset	0	0	0	0	0	0	0	0	0	0	0	0	0	0	0	0
	15	14	13	12	11	10	9	8	7	6	5	4	3	2	1	0
	reserved															VD
Type	RO	RO	RO	RO	RO	RO	RO	RO	RO	RO	RO	RO	RO	RO	RO	R/W
Reset	0	0	0	0	0	0	0	0	0	0	0	0	0	0	0	0

Bit/Field	Name	Type	Reset	Description
31:1	reserved	RO	0x0000.000	Software should not rely on the value of a reserved bit. To provide compatibility with future products, the value of a reserved bit should be preserved across a read-modify-write operation.
0	VD	R/W	0	VBUS Droop Interrupt Mask
				Value Description
			1	The raw interrupt signal from a detected VBUS droop is sent to the interrupt controller.
			0	A detected VBUS droop does not affect the interrupt status.

Register 176: USB VBUS Droop Control Interrupt Status and Clear (USBVDCISC), offset 0x43C

OTG A /
Host

This 32-bit register specifies the masked interrupt status of the VBUS droop and provides a method to clear the interrupt state.

USB VBUS Droop Control Interrupt Status and Clear (USBVDCISC)

Base 0x4005.0000

Offset 0x43C

Type R/W, reset 0x0000.0000

	31	30	29	28	27	26	25	24	23	22	21	20	19	18	17	16
	reserved															
Type	RO	RO	RO	RO	RO	RO	RO	RO	RO	RO	RO	RO	RO	RO	RO	RO
Reset	0	0	0	0	0	0	0	0	0	0	0	0	0	0	0	0
	15	14	13	12	11	10	9	8	7	6	5	4	3	2	1	0
	reserved															VD
Type	RO	RO	RO	RO	RO	RO	RO	RO	RO	RO	RO	RO	RO	RO	RO	R/W1C
Reset	0	0	0	0	0	0	0	0	0	0	0	0	0	0	0	0

Bit/Field	Name	Type	Reset	Description
31:1	reserved	RO	0x0000.000	Software should not rely on the value of a reserved bit. To provide compatibility with future products, the value of a reserved bit should be preserved across a read-modify-write operation.
0	VD	R/W1C	0	VBUS Droop Interrupt Status and Clear

Value Description

- | | |
|---|---|
| 1 | The \overline{VD} bits in the USBVDCRIS and USBVDCIM registers are set, providing an interrupt to the interrupt controller. |
| 0 | No interrupt has occurred or the interrupt is masked. |

This bit is cleared by writing a 1. Clearing this bit also clears the \overline{VD} bit in the **USBVDCRIS** register.

Register 177: USB ID Valid Detect Raw Interrupt Status (USBIDVRIS), offset 0x444

OTG

This 32-bit register specifies whether the unmasked interrupt status of the ID value is valid.

USB ID Valid Detect Raw Interrupt Status (USBIDVRIS)

Base 0x4005.0000
 Offset 0x444
 Type RO, reset 0x0000.0000

	31	30	29	28	27	26	25	24	23	22	21	20	19	18	17	16
	reserved															
Type	RO	RO	RO	RO	RO	RO	RO	RO	RO	RO	RO	RO	RO	RO	RO	RO
Reset	0	0	0	0	0	0	0	0	0	0	0	0	0	0	0	0
	15	14	13	12	11	10	9	8	7	6	5	4	3	2	1	0
	reserved															ID
Type	RO	RO	RO	RO	RO	RO	RO	RO	RO	RO	RO	RO	RO	RO	RO	RO
Reset	0	0	0	0	0	0	0	0	0	0	0	0	0	0	0	0

Bit/Field	Name	Type	Reset	Description
31:1	reserved	RO	0x0000.000	Software should not rely on the value of a reserved bit. To provide compatibility with future products, the value of a reserved bit should be preserved across a read-modify-write operation.
0	ID	RO	0	ID Valid Detect Raw Interrupt Status

Value	Description
1	A valid ID has been detected.
0	An interrupt has not occurred.

This bit is cleared by writing a 1 to the ID bit in the **USBIDVISC** register.

Register 178: USB ID Valid Detect Interrupt Mask (USBIDVIM), offset 0x448**OTG**

This 32-bit register specifies the interrupt mask of the ID valid detection.

USB ID Valid Detect Interrupt Mask (USBIDVIM)

Base 0x4005.0000
 Offset 0x448
 Type R/W, reset 0x0000.0000

	31	30	29	28	27	26	25	24	23	22	21	20	19	18	17	16
	reserved															
Type	RO	RO	RO	RO	RO	RO	RO	RO	RO	RO	RO	RO	RO	RO	RO	RO
Reset	0	0	0	0	0	0	0	0	0	0	0	0	0	0	0	0
	15	14	13	12	11	10	9	8	7	6	5	4	3	2	1	0
	reserved															ID
Type	RO	RO	RO	RO	RO	RO	RO	RO	RO	RO	RO	RO	RO	RO	RO	R/W
Reset	0	0	0	0	0	0	0	0	0	0	0	0	0	0	0	0

Bit/Field	Name	Type	Reset	Description
31:1	reserved	RO	0x0000.000	Software should not rely on the value of a reserved bit. To provide compatibility with future products, the value of a reserved bit should be preserved across a read-modify-write operation.
0	ID	R/W	0	ID Valid Detect Interrupt Mask

Value Description

- | | |
|---|--|
| 1 | The raw interrupt signal from a detected ID valid is sent to the interrupt controller. |
| 0 | A detected ID valid does not affect the interrupt status. |

Register 179: USB ID Valid Detect Interrupt Status and Clear (USBIDVISC), offset 0x44C

OTG

This 32-bit register specifies the masked interrupt status of the ID valid detect. It also provides a method to clear the interrupt state.

USB ID Valid Detect Interrupt Status and Clear (USBIDVISC)

Base 0x4005.0000
 Offset 0x44C
 Type R/W1C, reset 0x0000.0000

	31	30	29	28	27	26	25	24	23	22	21	20	19	18	17	16
	reserved															
Type	RO	RO	RO	RO	RO	RO	RO	RO	RO	RO	RO	RO	RO	RO	RO	RO
Reset	0	0	0	0	0	0	0	0	0	0	0	0	0	0	0	0
	15	14	13	12	11	10	9	8	7	6	5	4	3	2	1	0
	reserved															ID
Type	RO	RO	RO	RO	RO	RO	RO	RO	RO	RO	RO	RO	RO	RO	RO	R/W1C
Reset	0	0	0	0	0	0	0	0	0	0	0	0	0	0	0	0

Bit/Field	Name	Type	Reset	Description
31:1	reserved	RO	0x0000.000	Software should not rely on the value of a reserved bit. To provide compatibility with future products, the value of a reserved bit should be preserved across a read-modify-write operation.
0	ID	R/W1C	0	ID Valid Detect Interrupt Status and Clear

Value	Description
1	The ID bits in the USBIDVRIS and USBIDVIM registers are set, providing an interrupt to the interrupt controller.
0	No interrupt has occurred or the interrupt is masked.

This bit is cleared by writing a 1. Clearing this bit also clears the **ID** bit in the **USBIDVRIS** register.

Register 180: USB DMA Select (USBDMASEL), offset 0x450OTG A /
Host

This 32-bit register specifies which endpoints are mapped to the 6 allocated μ DMA channels, see Table 8-1 on page 561 for more information on channel assignments.

OTG B /
Device

USB DMA Select (USBDMASEL)

Base 0x4005.0000

Offset 0x450

Type R/W, reset 0x0033.2211

	31	30	29	28	27	26	25	24	23	22	21	20	19	18	17	16
	reserved								DMACTX				DMACRX			
Type	RO	RO	RO	RO	RO	RO	RO	RO	R/W	R/W	R/W	R/W	R/W	R/W	R/W	R/W
Reset	0	0	0	0	0	0	0	0	0	0	1	1	0	0	1	1
	15	14	13	12	11	10	9	8	7	6	5	4	3	2	1	0
	DMABTX				DMABRX				DMAATX				DMAARX			
Type	R/W	R/W	R/W	R/W	R/W	R/W	R/W	R/W	R/W	R/W	R/W	R/W	R/W	R/W	R/W	R/W
Reset	0	0	1	0	0	0	1	0	0	0	0	1	0	0	0	1

Bit/Field	Name	Type	Reset	Description																				
31:24	reserved	RO	0x00	Software should not rely on the value of a reserved bit. To provide compatibility with future products, the value of a reserved bit should be preserved across a read-modify-write operation.																				
23:20	DMACTX	R/W	0x3	DMA C TX Select Specifies the TX mapping of the third USB endpoint on μ DMA channel 5 (primary assignment). <table border="1"> <thead> <tr> <th>Value</th> <th>Description</th> </tr> </thead> <tbody> <tr> <td>0x0</td> <td>reserved</td> </tr> <tr> <td>0x1</td> <td>Endpoint 1 TX</td> </tr> <tr> <td>0x2</td> <td>Endpoint 2 TX</td> </tr> <tr> <td>0x3</td> <td>Endpoint 3 TX</td> </tr> <tr> <td>0x4</td> <td>Endpoint 4 TX</td> </tr> <tr> <td>0x5</td> <td>Endpoint 5 TX</td> </tr> <tr> <td>0x6</td> <td>Endpoint 6 TX</td> </tr> <tr> <td>0x7</td> <td>Endpoint 7 TX</td> </tr> <tr> <td>0x8 - 0xF</td> <td>reserved</td> </tr> </tbody> </table>	Value	Description	0x0	reserved	0x1	Endpoint 1 TX	0x2	Endpoint 2 TX	0x3	Endpoint 3 TX	0x4	Endpoint 4 TX	0x5	Endpoint 5 TX	0x6	Endpoint 6 TX	0x7	Endpoint 7 TX	0x8 - 0xF	reserved
Value	Description																							
0x0	reserved																							
0x1	Endpoint 1 TX																							
0x2	Endpoint 2 TX																							
0x3	Endpoint 3 TX																							
0x4	Endpoint 4 TX																							
0x5	Endpoint 5 TX																							
0x6	Endpoint 6 TX																							
0x7	Endpoint 7 TX																							
0x8 - 0xF	reserved																							

Bit/Field	Name	Type	Reset	Description																				
19:16	DMACRX	R/W	0x3	<p>DMA C RX Select</p> <p>Specifies the RX and TX mapping of the third USB endpoint on μDMA channel 4 (primary assignment).</p> <table border="1"> <thead> <tr> <th>Value</th> <th>Description</th> </tr> </thead> <tbody> <tr> <td>0x0</td> <td>reserved</td> </tr> <tr> <td>0x1</td> <td>Endpoint 1 RX</td> </tr> <tr> <td>0x2</td> <td>Endpoint 2 RX</td> </tr> <tr> <td>0x3</td> <td>Endpoint 3 RX</td> </tr> <tr> <td>0x4</td> <td>Endpoint 4 RX</td> </tr> <tr> <td>0x5</td> <td>Endpoint 5 RX</td> </tr> <tr> <td>0x6</td> <td>Endpoint 6 RX</td> </tr> <tr> <td>0x7</td> <td>Endpoint 7 RX</td> </tr> <tr> <td>0x8 - 0xF</td> <td>reserved</td> </tr> </tbody> </table>	Value	Description	0x0	reserved	0x1	Endpoint 1 RX	0x2	Endpoint 2 RX	0x3	Endpoint 3 RX	0x4	Endpoint 4 RX	0x5	Endpoint 5 RX	0x6	Endpoint 6 RX	0x7	Endpoint 7 RX	0x8 - 0xF	reserved
Value	Description																							
0x0	reserved																							
0x1	Endpoint 1 RX																							
0x2	Endpoint 2 RX																							
0x3	Endpoint 3 RX																							
0x4	Endpoint 4 RX																							
0x5	Endpoint 5 RX																							
0x6	Endpoint 6 RX																							
0x7	Endpoint 7 RX																							
0x8 - 0xF	reserved																							
15:12	DMABTX	R/W	0x2	<p>DMA B TX Select</p> <p>Specifies the TX mapping of the second USB endpoint on μDMA channel 3 (primary assignment).</p> <p>Same bit definitions as the <i>DMACTX</i> field.</p>																				
11:8	DMABRX	R/W	0x2	<p>DMA B RX Select</p> <p>Specifies the RX mapping of the second USB endpoint on μDMA channel 2 (primary assignment).</p> <p>Same bit definitions as the <i>DMACRX</i> field.</p>																				
7:4	DMAATX	R/W	0x1	<p>DMA A TX Select</p> <p>Specifies the TX mapping of the first USB endpoint on μDMA channel 1 (primary assignment).</p> <p>Same bit definitions as the <i>DMACTX</i> field.</p>																				
3:0	DMAARX	R/W	0x1	<p>DMA A RX Select</p> <p>Specifies the RX mapping of the first USB endpoint on μDMA channel 0 (primary assignment).</p> <p>Same bit definitions as the <i>DMACRX</i> field.</p>																				

Register 181: USB Peripheral Properties (USBPP), offset 0xFC0

The **USBPP** register provides information regarding the properties of the USB module.

USB Peripheral Properties (USBPP)

Base 0x4005.0000
Offset 0xFC0
Type RO, reset 0x0000.10D0

	31	30	29	28	27	26	25	24	23	22	21	20	19	18	17	16
	reserved															
Type	RO	RO	RO	RO	RO	RO	RO	RO	RO	RO	RO	RO	RO	RO	RO	RO
Reset	0	0	0	0	0	0	0	0	0	0	0	0	0	0	0	0
	15	14	13	12	11	10	9	8	7	6	5	4	3	2	1	0
	ECNT				USB				reserved	PHY	TYPE					
Type	RO	RO	RO	RO	RO	RO	RO	RO	RO	RO	RO	RO	RO	RO	RO	RO
Reset	0	0	0	1	0	0	0	0	1	1	0	1	0	0	0	0

Bit/Field	Name	Type	Reset	Description
31:16	reserved	RO	0x0	Software should not rely on the value of a reserved bit. To provide compatibility with future products, the value of a reserved bit should be preserved across a read-modify-write operation.
15:8	ECNT	RO	0x10	Endpoint Count This field defines the number of endpoints provided.
7:6	USB	RO	0x3	USB Capability Value Description 0x0 NA USB is not present. 0x1 DEVICE Device Only 0x2 HOST Device or Host 0x3 OTG Device, Host, or OTG
5	reserved	RO	0	Software should not rely on the value of a reserved bit. To provide compatibility with future products, the value of a reserved bit should be preserved across a read-modify-write operation.
4	PHY	RO	0x1	PHY Present Value Description 1 A PHY is integrated with the USB MAC. 0 A PHY is not integrated with the USB MAC.
3:0	TYPE	RO	0x0	Controller Type Value Description 0x0 The first-generation USB controller. 0x1 - 0xF Reserved

18 Analog Comparators

An analog comparator is a peripheral that compares two analog voltages and provides a logical output that signals the comparison result.

Note: Not all comparators have the option to drive an output pin. See “Signal Description” on page 1175 for more information.

The comparator can provide its output to a device pin, acting as a replacement for an analog comparator on the board. In addition, the comparator can signal the application via interrupts or trigger the start of a sample sequence in the ADC. The interrupt generation and ADC triggering logic is separate and independent. This flexibility means, for example, that an interrupt can be generated on a rising edge and the ADC triggered on a falling edge.

The Stellaris[®] LM4F231H5QR microcontroller provides two independent integrated analog comparators with the following functions:

- Compare external pin input to external pin input or to internal programmable voltage reference
- Compare a test voltage against any one of the following voltages:
 - An individual external reference voltage
 - A shared single external reference voltage
 - A shared internal reference voltage

18.1 Block Diagram

Figure 18-1. Analog Comparator Module Block Diagram

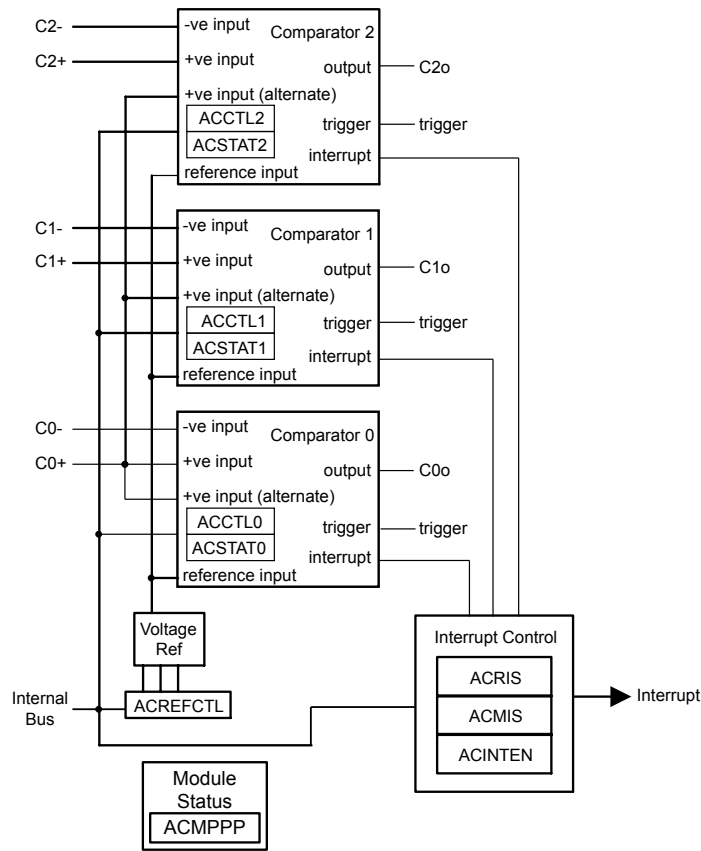

18.2 Signal Description

The following table lists the external signals of the Analog Comparators and describes the function of each. The Analog Comparator output signals are alternate functions for some GPIO signals and default to be GPIO signals at reset. The column in the table below titled "Pin Mux/Pin Assignment" lists the possible GPIO pin placements for the Analog Comparator signals. The `AFSEL` bit in the **GPIO Alternate Function Select (GPIOAFSEL)** register (page 644) should be set to choose the Analog Comparator function. The number in parentheses is the encoding that must be programmed into the `PMCn` field in the **GPIO Port Control (GPIOCTL)** register (page 661) to assign the Analog Comparator signal to the specified GPIO port pin. The positive and negative input signals are configured by clearing the `DEN` bit in the **GPIO Digital Enable (GPIODEN)** register. For more information on configuring GPIOs, see "General-Purpose Input/Outputs (GPIOs)" on page 623.

Table 18-1. Analog Comparators Signals (64LQFP)

Pin Name	Pin Number	Pin Mux / Pin Assignment	Pin Type	Buffer Type ^a	Description
C0+	14	PC6	I	Analog	Analog comparator 0 positive input.
C0-	13	PC7	I	Analog	Analog comparator 0 negative input.
C0o	28	PF0 (9)	O	TTL	Analog comparator 0 output.
C1+	15	PC5	I	Analog	Analog comparator 1 positive input.

Table 18-1. Analog Comparators Signals (64LQFP) (continued)

Pin Name	Pin Number	Pin Mux / Pin Assignment	Pin Type	Buffer Type ^a	Description
C1-	16	PC4	I	Analog	Analog comparator 1 negative input.
C1o	29	PF1 (9)	O	TTL	Analog comparator 1 output.

a. The TTL designation indicates the pin has TTL-compatible voltage levels.

18.3 Functional Description

The comparator compares the VIN- and VIN+ inputs to produce an output, VOUT.

$$VIN- < VIN+, VOUT = 1$$

$$VIN- > VIN+, VOUT = 0$$

As shown in Figure 18-2 on page 1176, the input source for VIN- is an external input, Cn-, where n is the analog comparator number. In addition to an external input, Cn+, input sources for VIN+ can be the C0+ or an internal reference, V_{IREF}.

Figure 18-2. Structure of Comparator Unit

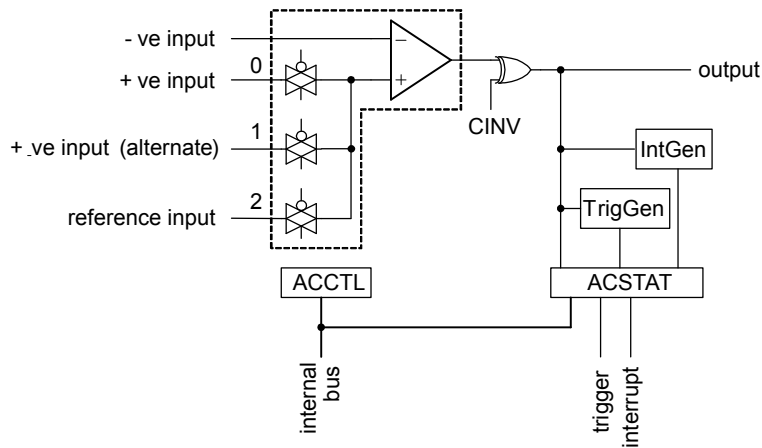

A comparator is configured through two status/control registers, **Analog Comparator Control (ACCTL)** and **Analog Comparator Status (ACSTAT)**. The internal reference is configured through one control register, **Analog Comparator Reference Voltage Control (ACREFCTL)**. Interrupt status and control are configured through three registers, **Analog Comparator Masked Interrupt Status (ACMIS)**, **Analog Comparator Raw Interrupt Status (ACRIS)**, and **Analog Comparator Interrupt Enable (ACINTEN)**.

Typically, the comparator output is used internally to generate an interrupt as controlled by the I_{SEN} bit in the **ACCTL** register. The output may also be used to drive one of the external pins (C0o, C1o, or C2o), or generate an analog-to-digital converter (ADC) trigger.

Important: The ASRCP bits in the **ACCTL** register must be set before using the analog comparators.

18.3.1 Internal Reference Programming

The structure of the internal reference is shown in Figure 18-3 on page 1177. The internal reference is controlled by a single configuration register (**ACREFCTL**).

Figure 18-3. Comparator Internal Reference Structure

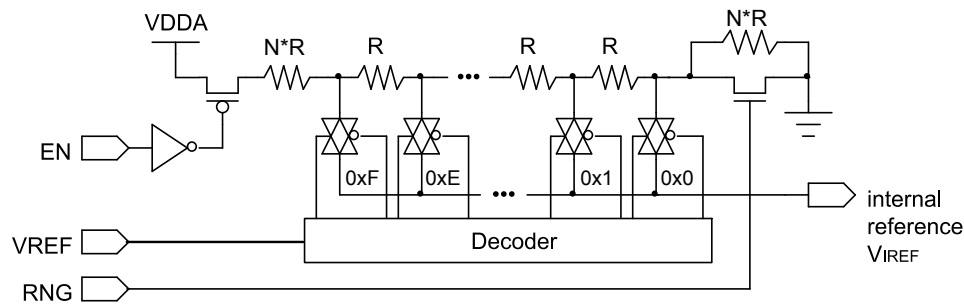

Note: In the figure above, N*R represents a multiple of the R value that produces the results specified in Table 18-2 on page 1177.

The internal reference can be programmed in one of two modes (low range or high range) depending on the **RNG** bit in the **ACREFCTL** register. When **RNG** is clear, the internal reference is in high-range mode, and when **RNG** is set the internal reference is in low-range mode.

In each range, the internal reference, V_{IREF} , has 16 pre-programmed thresholds or step values. The threshold to be used to compare the external input voltage against is selected using the **VREF** field in the **ACREFCTL** register.

In the high-range mode, the V_{IREF} threshold voltages start at the ideal high-range starting voltage of $V_{DDA}/4.2$ and increase in ideal constant voltage steps of $V_{DDA}/29.4$.

In the low-range mode, the V_{IREF} threshold voltages start at 0 V and increase in ideal constant voltage steps of $V_{DDA}/22.12$. The ideal V_{IREF} step voltages for each mode and their dependence on the **RNG** and **VREF** fields are summarized in Table 18-2.

Table 18-2. Internal Reference Voltage and ACREFCTL Field Values

ACREFCTL Register		Output Reference Voltage Based on VREF Field Value
EN Bit Value	RNG Bit Value	
EN=0	RNG=X	0 V (GND) for any value of VREF . It is recommended that RNG =1 and VREF =0 to minimize noise on the reference ground.
EN=1	RNG=0	V_{IREF} High Range: 16 voltage threshold values indexed by VREF = 0x0 .. 0xF Ideal starting voltage (VREF =0): $V_{DDA} / 4.2$ Ideal step size: $V_{DDA} / 29.4$ Ideal V_{IREF} threshold values: $V_{IREF} (VREF) = V_{DDA} / 4.2 + VREF * (V_{DDA} / 29.4)$, for VREF = 0x0 .. 0xF For minimum and maximum V_{IREF} threshold values, see Table 18-3 on page 1178.
	RNG=1	V_{IREF} Low Range: 16 voltage threshold values indexed by VREF = 0x0 .. 0xF Ideal starting voltage (VREF =0): 0 V Ideal step size: $V_{DDA} / 22.12$ Ideal V_{IREF} threshold values: $V_{IREF} (VREF) = VREF * (V_{DDA} / 22.12)$, for VREF = 0x0 .. 0xF For minimum and maximum V_{IREF} threshold values, see Table 18-4 on page 1178.

Note that the values shown in Table 18-2 are the ideal values of the V_{IREF} thresholds. These values actually vary between minimum and maximum values for each threshold step, depending on process and temperature. The minimum and maximum values for each step are given by:

- $V_{IREF}(V_{REF}) [\text{Min}] = \text{Ideal } V_{IREF}(V_{REF}) - (\text{Ideal Step size} - 2 \text{ mV}) / 2$
- $V_{IREF}(V_{REF}) [\text{Max}] = \text{Ideal } V_{IREF}(V_{REF}) + (\text{Ideal Step size} - 2 \text{ mV}) / 2$

Examples of minimum and maximum V_{IREF} values for $V_{DDA} = 3.3\text{V}$ for high and low ranges, are shown in Table 18-3 and Table 18-4. Note that these examples are only valid for $V_{DDA} = 3.3\text{V}$; values scale up and down with V_{DDA} .

Table 18-3. Analog Comparator Voltage Reference Characteristics, $V_{DDA} = 3.3\text{V}$, EN= 1, and RNG = 0

V_{REF} Value	V_{IREF} Min	Ideal V_{IREF}	V_{IREF} Max	Unit
0x0	0.731	0.786	0.841	V
0x1	0.843	0.898	0.953	V
0x2	0.955	1.010	1.065	V
0x3	1.067	1.122	1.178	V
0x4	1.180	1.235	1.290	V
0x5	1.292	1.347	1.402	V
0x6	1.404	1.459	1.514	V
0x7	1.516	1.571	1.627	V
0x8	1.629	1.684	1.739	V
0x9	1.741	1.796	1.851	V
0xA	1.853	1.908	1.963	V
0xB	1.965	2.020	2.076	V
0xC	2.078	2.133	2.188	V
0xD	2.190	2.245	2.300	V
0xE	2.302	2.357	2.412	V
0xF	2.414	2.469	2.525	V

Table 18-4. Analog Comparator Voltage Reference Characteristics, $V_{DDA} = 3.3\text{V}$, EN= 1, and RNG = 1

V_{REF} Value	V_{IREF} Min	Ideal V_{IREF}	V_{IREF} Max	Unit
0x0	0.000	0.000	0.074	V
0x1	0.076	0.149	0.223	V
0x2	0.225	0.298	0.372	V
0x3	0.374	0.448	0.521	V
0x4	0.523	0.597	0.670	V
0x5	0.672	0.746	0.820	V
0x6	0.822	0.895	0.969	V
0x7	0.971	1.044	1.118	V
0x8	1.120	1.193	1.267	V
0x9	1.269	1.343	1.416	V
0xA	1.418	1.492	1.565	V
0xB	1.567	1.641	1.715	V
0xC	1.717	1.790	1.864	V
0xD	1.866	1.939	2.013	V

Table 18-4. Analog Comparator Voltage Reference Characteristics, $V_{DDA} = 3.3V$, $EN = 1$, and $RNG = 1$ (continued)

VREF Value	V _{IREF} Min	Ideal V _{IREF}	V _{IREF} Max	Unit
0xE	2.015	2.089	2.162	V
0xF	2.164	2.238	2.311	V

18.4 Initialization and Configuration

The following example shows how to configure an analog comparator to read back its output value from an internal register.

1. Enable the analog comparator clock by writing a value of 0x0000.0001 to the **RCGCACMP** register in the System Control module (see page 331).
2. Enable the clock to the appropriate GPIO modules via the **RCGCGPIO** register (see page 319). To find out which GPIO ports to enable, refer to Table 22-5 on page 1314.
3. In the GPIO module, enable the GPIO port/pin associated with the input signals as GPIO inputs. To determine which GPIO to configure, see Table 22-4 on page 1307.
4. Configure the **PMC_n** fields in the **GPIOCTL** register to assign the analog comparator output signals to the appropriate pins (see page 661 and Table 22-5 on page 1314).
5. Configure the internal voltage reference to 1.65 V by writing the **ACREFCTL** register with the value 0x0000.030C.
6. Configure the comparator to use the internal voltage reference and to *not* invert the output by writing the **ACCTL_n** register with the value of 0x0000.040C.
7. Delay for 10 μ s.
8. Read the comparator output value by reading the **ACSTAT_n** register's **OVAL** value.

Change the level of the comparator negative input signal **C-** to see the **OVAL** value change.

18.5 Register Map

Table 18-5 on page 1179 lists the comparator registers. The offset listed is a hexadecimal increment to the register's address, relative to the Analog Comparator base address of 0x4003.C000. Note that the analog comparator clock must be enabled before the registers can be programmed (see page 331). There must be a delay of 3 system clocks after the analog comparator module clock is enabled before any analog comparator module registers are accessed.

Table 18-5. Analog Comparators Register Map

Offset	Name	Type	Reset	Description	See page
0x000	ACMIS	R/W1C	0x0000.0000	Analog Comparator Masked Interrupt Status	1181
0x004	ACRIS	RO	0x0000.0000	Analog Comparator Raw Interrupt Status	1182
0x008	ACINTEN	R/W	0x0000.0000	Analog Comparator Interrupt Enable	1183
0x010	ACREFCTL	R/W	0x0000.0000	Analog Comparator Reference Voltage Control	1184

Table 18-5. Analog Comparators Register Map (continued)

Offset	Name	Type	Reset	Description	See page
0x020	ACSTAT0	RO	0x0000.0000	Analog Comparator Status 0	1185
0x024	ACCTL0	R/W	0x0000.0000	Analog Comparator Control 0	1186
0x040	ACSTAT1	RO	0x0000.0000	Analog Comparator Status 1	1185
0x044	ACCTL1	R/W	0x0000.0000	Analog Comparator Control 1	1186
0xFC0	ACMPPP	RO	0x0003.0003	Analog Comparator Peripheral Properties	1188

18.6 Register Descriptions

The remainder of this section lists and describes the Analog Comparator registers, in numerical order by address offset.

Register 1: Analog Comparator Masked Interrupt Status (ACMIS), offset 0x000

This register provides a summary of the interrupt status (masked) of the comparators.

Analog Comparator Masked Interrupt Status (ACMIS)

Base 0x4003.C000

Offset 0x000

Type R/W1C, reset 0x0000.0000

	31	30	29	28	27	26	25	24	23	22	21	20	19	18	17	16	
	reserved																
Type	RO	RO	RO	RO	RO	RO	RO	RO	RO	RO	RO	RO	RO	RO	RO	RO	
Reset	0	0	0	0	0	0	0	0	0	0	0	0	0	0	0	0	
	15	14	13	12	11	10	9	8	7	6	5	4	3	2	1	0	
	reserved															IN1	IN0
Type	RO	RO	RO	RO	RO	RO	RO	RO	RO	RO	RO	RO	RO	RO	RO	R/W1C	R/W1C
Reset	0	0	0	0	0	0	0	0	0	0	0	0	0	0	0	0	0

Bit/Field	Name	Type	Reset	Description
31:2	reserved	RO	0x0000.000	Software should not rely on the value of a reserved bit. To provide compatibility with future products, the value of a reserved bit should be preserved across a read-modify-write operation.
1	IN1	R/W1C	0	<p>Comparator 1 Masked Interrupt Status</p> <p>Value Description</p> <p>1 The IN1 bits in the ACRIS register and the ACINTEN registers are set, providing an interrupt to the interrupt controller.</p> <p>0 No interrupt has occurred or the interrupt is masked.</p> <p>This bit is cleared by writing a 1. Clearing this bit also clears the IN1 bit in the ACRIS register.</p>
0	IN0	R/W1C	0	<p>Comparator 0 Masked Interrupt Status</p> <p>Value Description</p> <p>1 The IN0 bits in the ACRIS register and the ACINTEN registers are set, providing an interrupt to the interrupt controller.</p> <p>0 No interrupt has occurred or the interrupt is masked.</p> <p>This bit is cleared by writing a 1. Clearing this bit also clears the IN0 bit in the ACRIS register.</p>

Register 2: Analog Comparator Raw Interrupt Status (ACRIS), offset 0x004

This register provides a summary of the interrupt status (raw) of the comparators. The bits in this register must be enabled to generate interrupts using the **ACINTEN** register.

Analog Comparator Raw Interrupt Status (ACRIS)

Base 0x4003.C000

Offset 0x004

Type RO, reset 0x0000.0000

	31	30	29	28	27	26	25	24	23	22	21	20	19	18	17	16	
	reserved																
Type	RO	RO	RO	RO	RO	RO	RO	RO	RO	RO	RO	RO	RO	RO	RO	RO	
Reset	0	0	0	0	0	0	0	0	0	0	0	0	0	0	0	0	
	15	14	13	12	11	10	9	8	7	6	5	4	3	2	1	0	
	reserved															IN1	IN0
Type	RO	RO	RO	RO	RO	RO	RO	RO	RO	RO	RO	RO	RO	RO	RO	RO	RO
Reset	0	0	0	0	0	0	0	0	0	0	0	0	0	0	0	0	0

Bit/Field	Name	Type	Reset	Description
31:2	reserved	RO	0x0000.000	Software should not rely on the value of a reserved bit. To provide compatibility with future products, the value of a reserved bit should be preserved across a read-modify-write operation.
1	IN1	RO	0	<p>Comparator 1 Interrupt Status</p> <p>Value Description</p> <p>1 Comparator 1 has generated an interrupt for an event as configured by the ISEN bit in the ACCTL1 register.</p> <p>0 An interrupt has not occurred.</p> <p>This bit is cleared by writing a 1 to the IN1 bit in the ACMIS register.</p>
0	IN0	RO	0	<p>Comparator 0 Interrupt Status</p> <p>Value Description</p> <p>1 Comparator 0 has generated an interrupt for an event as configured by the ISEN bit in the ACCTL0 register.</p> <p>0 An interrupt has not occurred.</p> <p>This bit is cleared by writing a 1 to the IN0 bit in the ACMIS register.</p>

Register 3: Analog Comparator Interrupt Enable (ACINTEN), offset 0x008

This register provides the interrupt enable for the comparators.

Analog Comparator Interrupt Enable (ACINTEN)

Base 0x4003.C000

Offset 0x008

Type R/W, reset 0x0000.0000

	31	30	29	28	27	26	25	24	23	22	21	20	19	18	17	16	
	reserved																
Type	RO	RO	RO	RO	RO	RO	RO	RO	RO	RO	RO	RO	RO	RO	RO	RO	
Reset	0	0	0	0	0	0	0	0	0	0	0	0	0	0	0	0	
	15	14	13	12	11	10	9	8	7	6	5	4	3	2	1	0	
	reserved														IN1	IN0	
Type	RO	RO	RO	RO	RO	RO	RO	RO	RO	RO	RO	RO	RO	RO	RO	R/W	R/W
Reset	0	0	0	0	0	0	0	0	0	0	0	0	0	0	0	0	0

Bit/Field	Name	Type	Reset	Description
31:2	reserved	RO	0x00	Software should not rely on the value of a reserved bit. To provide compatibility with future products, the value of a reserved bit should be preserved across a read-modify-write operation.
1	IN1	R/W	0	Comparator 1 Interrupt Enable Value Description 1 The raw interrupt signal comparator 1 is sent to the interrupt controller. 0 A comparator 1 interrupt does not affect the interrupt status.
0	IN0	R/W	0	Comparator 0 Interrupt Enable Value Description 1 The raw interrupt signal comparator 0 is sent to the interrupt controller. 0 A comparator 0 interrupt does not affect the interrupt status.

Register 4: Analog Comparator Reference Voltage Control (ACREFCTL), offset 0x010

This register specifies whether the resistor ladder is powered on as well as the range and tap.

Analog Comparator Reference Voltage Control (ACREFCTL)

Base 0x4003.C000

Offset 0x010

Type R/W, reset 0x0000.0000

	31	30	29	28	27	26	25	24	23	22	21	20	19	18	17	16	
	reserved																
Type	RO	RO	RO	RO	RO	RO	RO	RO	RO	RO	RO	RO	RO	RO	RO	RO	
Reset	0	0	0	0	0	0	0	0	0	0	0	0	0	0	0	0	
	15	14	13	12	11	10	9	8	7	6	5	4	3	2	1	0	
	reserved						EN	RNG	reserved					VREF			
Type	RO	RO	RO	RO	RO	RO	R/W	R/W	RO	RO	RO	RO	R/W	R/W	R/W	R/W	
Reset	0	0	0	0	0	0	0	0	0	0	0	0	0	0	0	0	

Bit/Field	Name	Type	Reset	Description
31:10	reserved	RO	0x0000.0	Software should not rely on the value of a reserved bit. To provide compatibility with future products, the value of a reserved bit should be preserved across a read-modify-write operation.
9	EN	R/W	0	Resistor Ladder Enable Value Description 0 The resistor ladder is unpowered. 1 Powers on the resistor ladder. The resistor ladder is connected to V_{DDA} . This bit is cleared at reset so that the internal reference consumes the least amount of power if it is not used.
8	RNG	R/W	0	Resistor Ladder Range Value Description 0 The ideal step size for the internal reference is $V_{DDA} / 29.4$. 1 The ideal step size for the internal reference is $V_{DDA} / 22.12$.
7:4	reserved	RO	0x0	Software should not rely on the value of a reserved bit. To provide compatibility with future products, the value of a reserved bit should be preserved across a read-modify-write operation.
3:0	VREF	R/W	0x0	Resistor Ladder Voltage Ref The V_{REF} bit field specifies the resistor ladder tap that is passed through an analog multiplexer. The voltage corresponding to the tap position is the internal reference voltage available for comparison. See Table 18-2 on page 1177 for some output reference voltage examples.

Register 5: Analog Comparator Status 0 (ACSTAT0), offset 0x020**Register 6: Analog Comparator Status 1 (ACSTAT1), offset 0x040**

These registers specify the current output value of the comparator.

Analog Comparator Status n (ACSTATn)

Base 0x4003.C000

Offset 0x020

Type RO, reset 0x0000.0000

	31	30	29	28	27	26	25	24	23	22	21	20	19	18	17	16	
	reserved																
Type	RO	RO	RO	RO	RO	RO	RO	RO	RO	RO	RO	RO	RO	RO	RO	RO	
Reset	0	0	0	0	0	0	0	0	0	0	0	0	0	0	0	0	
	15	14	13	12	11	10	9	8	7	6	5	4	3	2	1	0	
	reserved															OVAL	reserved
Type	RO	RO	RO	RO	RO	RO	RO	RO	RO	RO	RO	RO	RO	RO	RO	RO	RO
Reset	0	0	0	0	0	0	0	0	0	0	0	0	0	0	0	0	0

Bit/Field	Name	Type	Reset	Description
31:2	reserved	RO	0x0000.000	Software should not rely on the value of a reserved bit. To provide compatibility with future products, the value of a reserved bit should be preserved across a read-modify-write operation.
1	OVAL	RO	0	Comparator Output Value Value Description 0 VIN- > VIN+ 1 VIN- < VIN+ VIN- is the voltage on the Cn- pin. VIN+ is the voltage on the Cn+ pin, the C0+ pin, or the internal voltage reference (V _{IREF}) as defined by the ASRCP bit in the ACCTL register.
0	reserved	RO	0	Software should not rely on the value of a reserved bit. To provide compatibility with future products, the value of a reserved bit should be preserved across a read-modify-write operation.

Register 7: Analog Comparator Control 0 (ACCTL0), offset 0x024

Register 8: Analog Comparator Control 1 (ACCTL1), offset 0x044

These registers configure the comparator's input and output.

Analog Comparator Control n (ACCTLn)

Base 0x4003.C000
 Offset 0x024
 Type R/W, reset 0x0000.0000

	31	30	29	28	27	26	25	24	23	22	21	20	19	18	17	16	
	reserved																
Type	RO	RO	RO	RO	RO	RO	RO	RO	RO	RO	RO	RO	RO	RO	RO	RO	
Reset	0	0	0	0	0	0	0	0	0	0	0	0	0	0	0	0	
	15	14	13	12	11	10	9	8	7	6	5	4	3	2	1	0	
	reserved				TOEN	ASRCP			reserved	TSLVAL	TSEN		ISLVAL	ISEN		CINV	reserved
Type	RO	RO	RO	RO	R/W	R/W	R/W	RO	R/W	R/W	R/W	R/W	R/W	R/W	R/W	RO	
Reset	0	0	0	0	0	0	0	0	0	0	0	0	0	0	0	0	

Bit/Field	Name	Type	Reset	Description
31:12	reserved	RO	0x0000.0	Software should not rely on the value of a reserved bit. To provide compatibility with future products, the value of a reserved bit should be preserved across a read-modify-write operation.
11	TOEN	R/W	0	Trigger Output Enable Value Description 0 ADC events are suppressed and not sent to the ADC. 1 ADC events are sent to the ADC.
10:9	ASRCP	R/W	0x0	Analog Source Positive The ASRCP field specifies the source of input voltage to the VIN+ terminal of the comparator. The encodings for this field are as follows: Value Description 0x0 Pin value of Cn+ 0x1 Pin value of C0+ 0x2 Internal voltage reference (V _{IREF}) 0x3 Reserved
8	reserved	RO	0	Software should not rely on the value of a reserved bit. To provide compatibility with future products, the value of a reserved bit should be preserved across a read-modify-write operation.
7	TSLVAL	R/W	0	Trigger Sense Level Value Value Description 0 An ADC event is generated if the comparator output is Low. 1 An ADC event is generated if the comparator output is High.

Bit/Field	Name	Type	Reset	Description										
6:5	TSEN	R/W	0x0	<p>Trigger Sense</p> <p>The TSEN field specifies the sense of the comparator output that generates an ADC event. The sense conditioning is as follows:</p> <table border="1"> <thead> <tr> <th>Value</th> <th>Description</th> </tr> </thead> <tbody> <tr> <td>0x0</td> <td>Level sense, see TSLVAL</td> </tr> <tr> <td>0x1</td> <td>Falling edge</td> </tr> <tr> <td>0x2</td> <td>Rising edge</td> </tr> <tr> <td>0x3</td> <td>Either edge</td> </tr> </tbody> </table>	Value	Description	0x0	Level sense, see TSLVAL	0x1	Falling edge	0x2	Rising edge	0x3	Either edge
Value	Description													
0x0	Level sense, see TSLVAL													
0x1	Falling edge													
0x2	Rising edge													
0x3	Either edge													
4	ISLVAL	R/W	0	<p>Interrupt Sense Level Value</p> <table border="1"> <thead> <tr> <th>Value</th> <th>Description</th> </tr> </thead> <tbody> <tr> <td>0</td> <td>An interrupt is generated if the comparator output is Low.</td> </tr> <tr> <td>1</td> <td>An interrupt is generated if the comparator output is High.</td> </tr> </tbody> </table>	Value	Description	0	An interrupt is generated if the comparator output is Low.	1	An interrupt is generated if the comparator output is High.				
Value	Description													
0	An interrupt is generated if the comparator output is Low.													
1	An interrupt is generated if the comparator output is High.													
3:2	ISEN	R/W	0x0	<p>Interrupt Sense</p> <p>The ISEN field specifies the sense of the comparator output that generates an interrupt. The sense conditioning is as follows:</p> <table border="1"> <thead> <tr> <th>Value</th> <th>Description</th> </tr> </thead> <tbody> <tr> <td>0x0</td> <td>Level sense, see ISLVAL</td> </tr> <tr> <td>0x1</td> <td>Falling edge</td> </tr> <tr> <td>0x2</td> <td>Rising edge</td> </tr> <tr> <td>0x3</td> <td>Either edge</td> </tr> </tbody> </table>	Value	Description	0x0	Level sense, see ISLVAL	0x1	Falling edge	0x2	Rising edge	0x3	Either edge
Value	Description													
0x0	Level sense, see ISLVAL													
0x1	Falling edge													
0x2	Rising edge													
0x3	Either edge													
1	CINV	R/W	0	<p>Comparator Output Invert</p> <table border="1"> <thead> <tr> <th>Value</th> <th>Description</th> </tr> </thead> <tbody> <tr> <td>0</td> <td>The output of the comparator is unchanged.</td> </tr> <tr> <td>1</td> <td>The output of the comparator is inverted prior to being processed by hardware.</td> </tr> </tbody> </table>	Value	Description	0	The output of the comparator is unchanged.	1	The output of the comparator is inverted prior to being processed by hardware.				
Value	Description													
0	The output of the comparator is unchanged.													
1	The output of the comparator is inverted prior to being processed by hardware.													
0	reserved	RO	0	Software should not rely on the value of a reserved bit. To provide compatibility with future products, the value of a reserved bit should be preserved across a read-modify-write operation.										

Register 9: Analog Comparator Peripheral Properties (ACMPPP), offset 0xFC0

The **ACMPPP** register provides information regarding the properties of the analog comparator module.

Analog Comparator Peripheral Properties (ACMPPP)

Base 0x4003.C000
 Offset 0xFC0
 Type RO, reset 0x0003.0003

	31	30	29	28	27	26	25	24	23	22	21	20	19	18	17	16
	reserved														C10	C00
Type	RO	RO	RO	RO	RO	RO	RO	RO	RO	RO	RO	RO	RO	RO	RO	RO
Reset	0	0	0	0	0	0	0	0	0	0	0	0	0	0	1	1
	15	14	13	12	11	10	9	8	7	6	5	4	3	2	1	0
	reserved														CMP1	CMP0
Type	RO	RO	RO	RO	RO	RO	RO	RO	RO	RO	RO	RO	RO	RO	RO	RO
Reset	0	0	0	0	0	0	0	0	0	0	0	0	0	0	1	1

Bit/Field	Name	Type	Reset	Description
31:18	reserved	RO	0x0	Software should not rely on the value of a reserved bit. To provide compatibility with future products, the value of a reserved bit should be preserved across a read-modify-write operation.
17	C10	RO	0x1	Comparator Output 1 Present Value Description 1 Comparator output 1 is present. 0 Comparator output 1 is not present.
16	C00	RO	0x1	Comparator Output 0 Present Value Description 1 Comparator output 0 is present. 0 Comparator output 0 is not present.
15:2	reserved	RO	0x0	Software should not rely on the value of a reserved bit. To provide compatibility with future products, the value of a reserved bit should be preserved across a read-modify-write operation.
1	CMP1	RO	0x1	Comparator 1 Present Value Description 1 Comparator 1 is present. 0 Comparator 1 is not present.
0	CMP0	RO	0x1	Comparator 0 Present Value Description 1 Comparator 0 is present. 0 Comparator 0 is not present.

19 Pulse Width Modulator (PWM)

Pulse width modulation (PWM) is a powerful technique for digitally encoding analog signal levels. High-resolution counters are used to generate a square wave, and the duty cycle of the square wave is modulated to encode an analog signal. Typical applications include switching power supplies and motor control.

The Stellaris® microcontroller contains two PWM modules, each with four PWM generator blocks and a control block, for a total of 16 PWM outputs. The control block determines the polarity of the PWM signals, and which signals are passed through to the pins.

Each PWM generator block produces two PWM signals that share the same timer and frequency and can either be programmed with independent actions or as a single pair of complementary signals with dead-band delays inserted. The output signals, `pwmA'` and `pwmB'`, of the PWM generation blocks are managed by the output control block before being passed to the device pins as `MnPWM0` and `MnPWM1` or `MnPWM2` and `MnPWM3`, and so on.

Each Stellaris PWM module provides a great deal of flexibility and can generate simple PWM signals, such as those required by a simple charge pump as well as paired PWM signals with dead-band delays, such as those required by a half-H bridge driver. Three generator blocks can also generate the full six channels of gate controls required by a 3-phase inverter bridge.

Each PWM generator block has the following features:

- Three fault-condition handling inputs to quickly provide low-latency shutdown and prevent damage to the motor being controlled, for a total of six inputs
- One 16-bit counter
 - Runs in Down or Up/Down mode
 - Output frequency controlled by a 16-bit load value
 - Load value updates can be synchronized
 - Produces output signals at zero and load value
- Two PWM comparators
 - Comparator value updates can be synchronized
 - Produces output signals on match
- PWM signal generator
 - Output PWM signal is constructed based on actions taken as a result of the counter and PWM comparator output signals
 - Produces two independent PWM signals
- Dead-band generator
 - Produces two PWM signals with programmable dead-band delays suitable for driving a half-H bridge
 - Can be bypassed, leaving input PWM signals unmodified

- Can initiate an ADC sample sequence

The control block determines the polarity of the PWM signals and which signals are passed through to the pins. The output of the PWM generation blocks are managed by the output control block before being passed to the device pins. The PWM control block has the following options:

- PWM output enable of each PWM signal
- Optional output inversion of each PWM signal (polarity control)
- Optional fault handling for each PWM signal
- Synchronization of timers in the PWM generator blocks
- Synchronization of timer/comparator updates across the PWM generator blocks
- Extended PWM synchronization of timer/comparator updates across the PWM generator blocks
- Interrupt status summary of the PWM generator blocks
- Extended PWM fault handling, with multiple fault signals, programmable polarities, and filtering
- PWM generators can be operated independently or synchronized with other generators

19.1 Block Diagram

Figure 19-1 on page 1191 provides the Stellaris PWM module diagram and Figure 19-2 on page 1191 provides a more detailed diagram of a Stellaris PWM generator. The LM4F231H5QR controller contains two PWM modules, each with four generator blocks that generate eight independent PWM signals or four paired PWM signals with dead-band delays inserted.

Figure 19-1. PWM Module Diagram

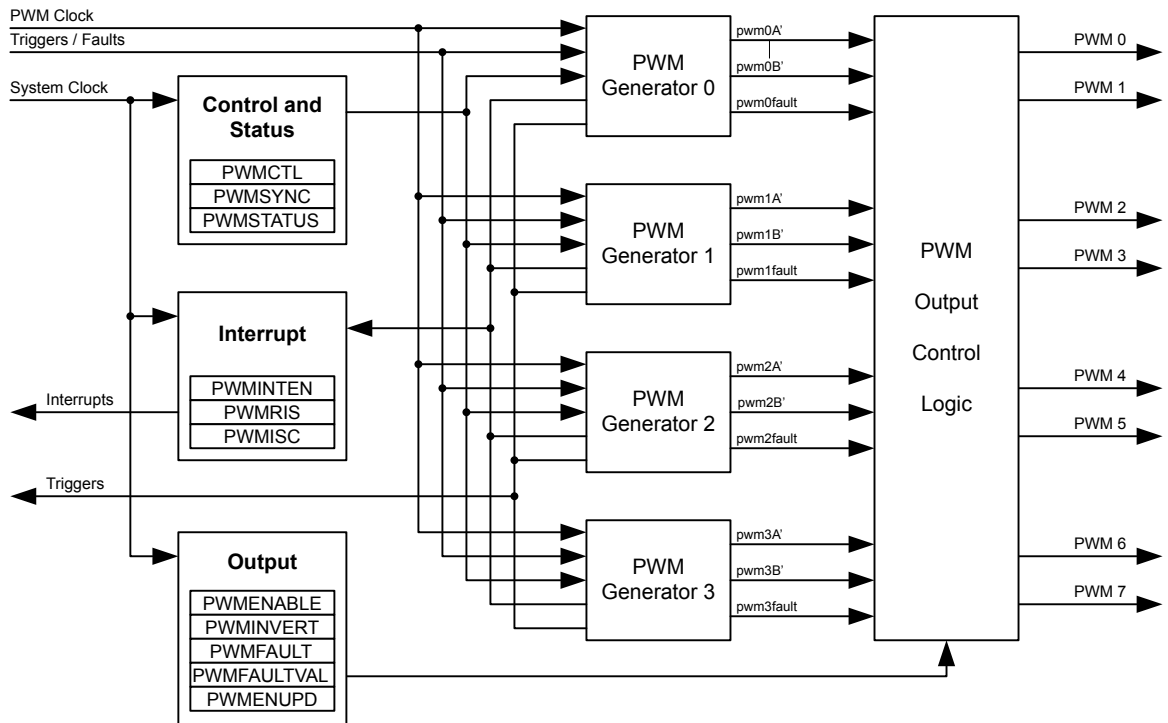
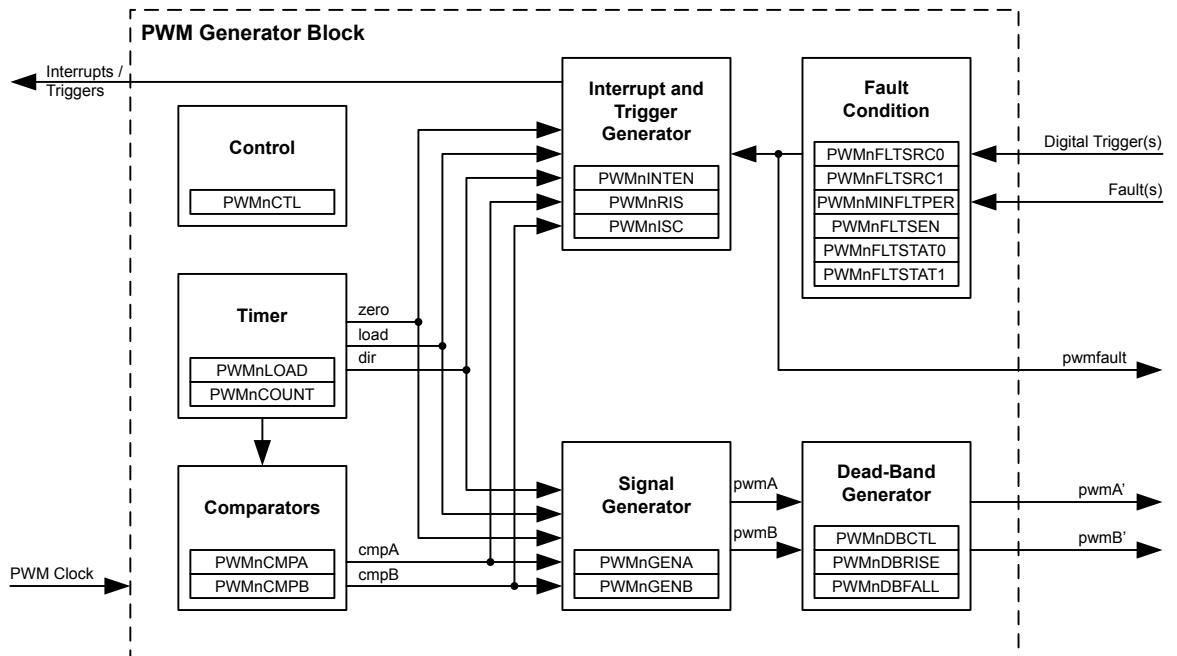

Figure 19-2. PWM Generator Block Diagram



19.2 Signal Description

The following table lists the external signals of the PWM modules and describes the function of each. The PWM controller signals are alternate functions for some GPIO signals and default to be

GPIO signals at reset. The column in the table below titled "Pin Mux/Pin Assignment" lists the possible GPIO pin placements for these PWM signals. The **AFSEL** bit in the **GPIO Alternate Function Select (GPIOAFSEL)** register (page 644) should be set to choose the PWM function. The number in parentheses is the encoding that must be programmed into the **PMC_n** field in the **GPIO Port Control (GPIOCTL)** register (page 661) to assign the PWM signal to the specified GPIO port pin. For more information on configuring GPIOs, see "General-Purpose Input/Outputs (GPIOs)" on page 623.

Table 19-1. PWM Signals (64LQFP)

Pin Name	Pin Number	Pin Mux / Pin Assignment	Pin Type	Buffer Type ^a	Description
M0FAULT0	30 53 63	PF2 (4) PD6 (4) PD2 (4)	I	TTL	Motion Control Module 0 PWM Fault 0.
M0FAULT1	10 31 35	PD7 (4) PF3 (4) PG2 (4)	I	TTL	Motion Control Module 0 PWM Fault 1.
M0FAULT2	5 34	PF4 (4) PG3 (4)	I	TTL	Motion Control Module 0 PWM Fault 2.
M0PWM0	1	PB6 (4)	O	TTL	Motion Control Module 0 PWM 0. This signal is controlled by Module 0 PWM Generator 0.
M0PWM1	4	PB7 (4)	O	TTL	Motion Control Module 0 PWM 1. This signal is controlled by Module 0 PWM Generator 0.
M0PWM2	58	PB4 (4)	O	TTL	Motion Control Module 0 PWM 2. This signal is controlled by Module 0 PWM Generator 1.
M0PWM3	57	PB5 (4)	O	TTL	Motion Control Module 0 PWM 3. This signal is controlled by Module 0 PWM Generator 1.
M0PWM4	33 59	PG4 (4) PE4 (4)	O	TTL	Motion Control Module 0 PWM 4. This signal is controlled by Module 0 PWM Generator 2.
M0PWM5	32 60	PG5 (4) PE5 (4)	O	TTL	Motion Control Module 0 PWM 5. This signal is controlled by Module 0 PWM Generator 2.
M0PWM6	16 61	PC4 (4) PD0 (4)	O	TTL	Motion Control Module 0 PWM 6. This signal is controlled by Module 0 PWM Generator 3.
M0PWM7	15 62	PC5 (4) PD1 (4)	O	TTL	Motion Control Module 0 PWM 7. This signal is controlled by Module 0 PWM Generator 3.
M1FAULT0	5	PF4 (5)	I	TTL	Motion Control Module 1 PWM Fault 0.
M1FAULT1	37	PG0 (5)	I	TTL	Motion Control Module 1 PWM Fault 1.
M1FAULT2	36	PG1 (5)	I	TTL	Motion Control Module 1 PWM Fault 2.
M1PWM0	35 61	PG2 (5) PD0 (5)	O	TTL	Motion Control Module 1 PWM 0. This signal is controlled by Module 1 PWM Generator 0.
M1PWM1	34 62	PG3 (5) PD1 (5)	O	TTL	Motion Control Module 1 PWM 1. This signal is controlled by Module 1 PWM Generator 0.
M1PWM2	23 33 59	PA6 (5) PG4 (5) PE4 (5)	O	TTL	Motion Control Module 1 PWM 2. This signal is controlled by Module 1 PWM Generator 1.
M1PWM3	24 32 60	PA7 (5) PG5 (5) PE5 (5)	O	TTL	Motion Control Module 1 PWM 3. This signal is controlled by Module 1 PWM Generator 1.
M1PWM4	28	PF0 (5)	O	TTL	Motion Control Module 1 PWM 4. This signal is controlled by Module 1 PWM Generator 2.

Table 19-1. PWM Signals (64LQFP) (continued)

Pin Name	Pin Number	Pin Mux / Pin Assignment	Pin Type	Buffer Type ^a	Description
M1PWM5	29	PF1 (5)	O	TTL	Motion Control Module 1 PWM 5. This signal is controlled by Module 1 PWM Generator 2.
M1PWM6	30	PF2 (5)	O	TTL	Motion Control Module 1 PWM 6. This signal is controlled by Module 1 PWM Generator 3.
M1PWM7	31	PF3 (5)	O	TTL	Motion Control Module 1 PWM 7. This signal is controlled by Module 1 PWM Generator 3.

a. The TTL designation indicates the pin has TTL-compatible voltage levels.

19.3 Functional Description

19.3.1 PWM Timer

The timer in each PWM generator runs in one of two modes: Count-Down mode or Count-Up/Down mode. In Count-Down mode, the timer counts from the load value to zero, goes back to the load value, and continues counting down. In Count-Up/Down mode, the timer counts from zero up to the load value, back down to zero, back up to the load value, and so on. Generally, Count-Down mode is used for generating left- or right-aligned PWM signals, while the Count-Up/Down mode is used for generating center-aligned PWM signals.

The timers output three signals that are used in the PWM generation process: the direction signal (this is always Low in Count-Down mode, but alternates between Low and High in Count-Up/Down mode), a single-clock-cycle-width High pulse when the counter is zero, and a single-clock-cycle-width High pulse when the counter is equal to the load value. Note that in Count-Down mode, the zero pulse is immediately followed by the load pulse. In the figures in this chapter, these signals are labelled "dir," "zero," and "load."

19.3.2 PWM Comparators

Each PWM generator has two comparators that monitor the value of the counter; when either comparator matches the counter, they output a single-clock-cycle-width High pulse, labelled "cmpA" and "cmpB" in the figures in this chapter. When in Count-Up/Down mode, these comparators match both when counting up and when counting down, and thus are qualified by the counter direction signal. These qualified pulses are used in the PWM generation process. If either comparator match value is greater than the counter load value, then that comparator never outputs a High pulse.

Figure 19-3 on page 1194 shows the behavior of the counter and the relationship of these pulses when the counter is in Count-Down mode. Figure 19-4 on page 1194 shows the behavior of the counter and the relationship of these pulses when the counter is in Count-Up/Down mode. In these figures, the following definitions apply:

- LOAD is the value in the **PWMnLOAD** register
- COMPA is the value in the **PWMnCMPA** register
- COMPB is the value in the **PWMnCMPB** register
- 0 is the value zero
- load is the internal signal that has a single-clock-cycle-width High pulse when the counter is equal to the load value
- zero is the internal signal that has a single-clock-cycle-width High pulse when the counter is zero

- cmpA is the internal signal that has a single-clock-cycle-width High pulse when the counter is equal to COMPA
- cmpB is the internal signal that has a single-clock-cycle-width High pulse when the counter is equal to COMPB
- dir is the internal signal that indicates the count direction

Figure 19-3. PWM Count-Down Mode

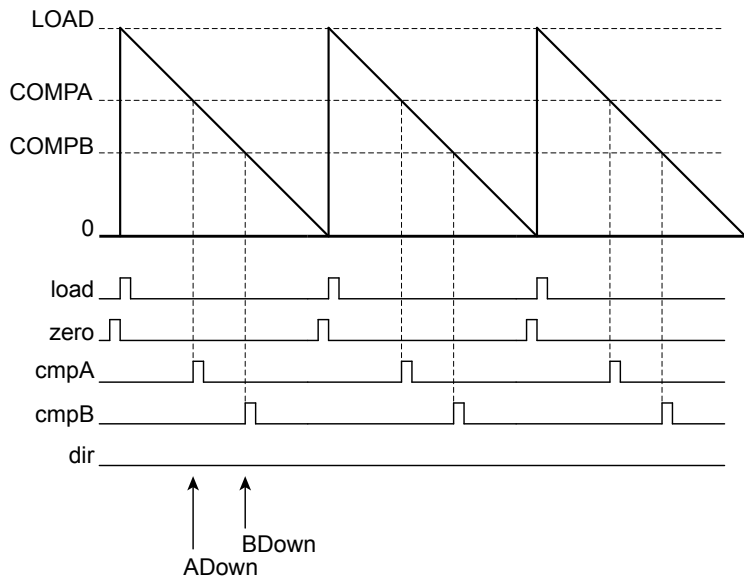
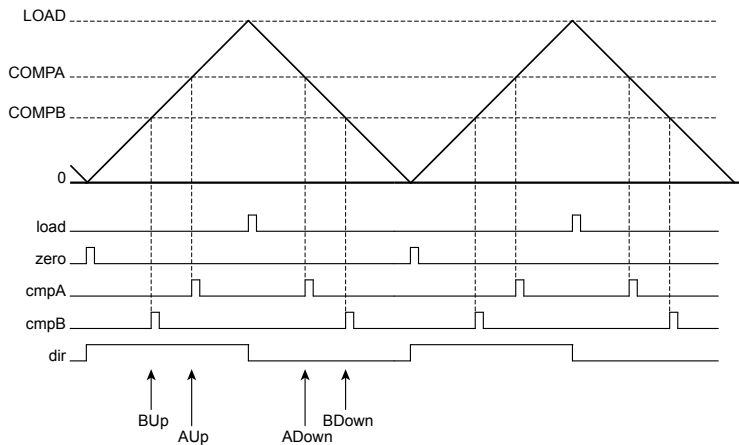

Figure 19-4. PWM Count-Up/Down Mode



19.3.3 PWM Signal Generator

Each PWM generator takes the load, zero, cmpA, and cmpB pulses (qualified by the dir signal) and generates two internal PWM signals, pwmA and pwmB. In Count-Down mode, there are four events that can affect these signals: zero, load, match A down, and match B down. In Count-Up/Down mode, there are six events that can affect these signals: zero, load, match A down, match A up, match B down, and match B up. The match A or match B events are ignored when they coincide with the zero or load events. If the match A and match B events coincide, the first signal, pwmA, is

generated based only on the match A event, and the second signal, pwmB, is generated based only on the match B event.

For each event, the effect on each output PWM signal is programmable: it can be left alone (ignoring the event), it can be toggled, it can be driven Low, or it can be driven High. These actions can be used to generate a pair of PWM signals of various positions and duty cycles, which do or do not overlap. Figure 19-5 on page 1195 shows the use of Count-Up/Down mode to generate a pair of center-aligned, overlapped PWM signals that have different duty cycles. This figure shows the pwmA and pwmB signals before they have passed through the dead-band generator.

Figure 19-5. PWM Generation Example In Count-Up/Down Mode

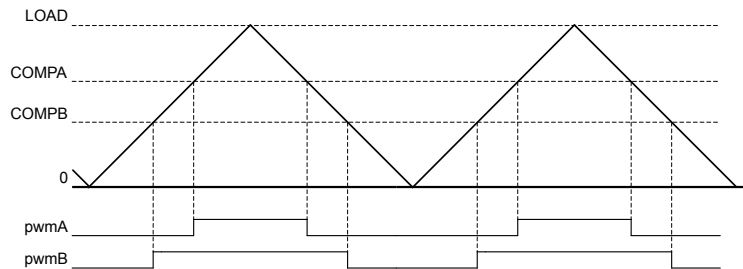

In this example, the first generator is set to drive High on match A up, drive Low on match A down, and ignore the other four events. The second generator is set to drive High on match B up, drive Low on match B down, and ignore the other four events. Changing the value of comparator A changes the duty cycle of the pwmA signal, and changing the value of comparator B changes the duty cycle of the pwmB signal.

19.3.4 Dead-Band Generator

The pwmA and pwmB signals produced by each PWM generator are passed to the dead-band generator. If the dead-band generator is disabled, the PWM signals simply pass through to the pwmA' and pwmB' signals unmodified. If the dead-band generator is enabled, the pwmB signal is lost and two PWM signals are generated based on the pwmA signal. The first output PWM signal, pwmA' is the pwmA signal with the rising edge delayed by a programmable amount. The second output PWM signal, pwmB', is the inversion of the pwmA signal with a programmable delay added between the falling edge of the pwmA signal and the rising edge of the pwmB' signal.

The resulting signals are a pair of active High signals where one is always High, except for a programmable amount of time at transitions where both are Low. These signals are therefore suitable for driving a half-H bridge, with the dead-band delays preventing shoot-through current from damaging the power electronics. Figure 19-6 on page 1195 shows the effect of the dead-band generator on the pwmA signal and the resulting pwmA' and pwmB' signals that are transmitted to the output control block.

Figure 19-6. PWM Dead-Band Generator

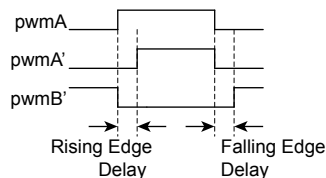

19.3.5 Interrupt/ADC-Trigger Selector

Each PWM generator also takes the same four (or six) counter events and uses them to generate an interrupt or an ADC trigger. Any of these events or a set of these events can be selected as a source for an interrupt; when any of the selected events occur, an interrupt is generated. Additionally, the same event, a different event, the same set of events, or a different set of events can be selected as a source for an ADC trigger; when any of these selected events occur, an ADC trigger pulse is generated. The selection of events allows the interrupt or ADC trigger to occur at a specific position within the pwmA or pwmB signal. Note that interrupts and ADC triggers are based on the raw events; delays in the PWM signal edges caused by the dead-band generator are not taken into account.

19.3.6 Synchronization Methods

Each PWM module provides four PWM generators, each providing two PWM outputs that may be used in a wide variety of applications. Generally speaking, the PWM is used in one of two categories of operation:

- **Unsynchronized.** The PWM generator and its two output signals are used alone, independent of other PWM generators.
- **Synchronized.** The PWM generator and its two outputs signals are used in conjunction with other PWM generators using a common, unified time base. If multiple PWM generators are configured with the same counter load value, synchronization can be used to guarantee that they also have the same count value (the PWM generators must be configured before they are synchronized). With this feature, more than two $MnPWMn$ signals can be produced with a known relationship between the edges of those signals because the counters always have the same values. Other states in the module provide mechanisms to maintain the common time base and mutual synchronization.

The counter in a PWM generator can be reset to zero by writing the **PWM Time Base Sync (PWMSYNC)** register and setting the $SYNCn$ bit associated with the generator. Multiple PWM generators can be synchronized together by setting all necessary $SYNCn$ bits in one access. For example, setting the $SYNC0$ and $SYNC1$ bits in the **PWMSYNC** register causes the counters in PWM generators 0 and 1 to reset together.

Additional synchronization can occur between multiple PWM generators by updating register contents in one of the following three ways:

- **Immediately.** The write value has immediate effect, and the hardware reacts immediately.
- **Locally Synchronized.** The write value does not affect the logic until the counter reaches the value zero at the end of the PWM cycle. In this case, the effect of the write is deferred, providing a guaranteed defined behavior and preventing overly short or overly long output PWM pulses.
- **Globally Synchronized.** The write value does not affect the logic until two sequential events have occurred: (1) the Update mode for the generator function is programmed for global synchronization in the **PWMnCTL** register, and (2) the counter reaches zero at the end of the PWM cycle. In this case, the effect of the write is deferred until the end of the PWM cycle following the end of all updates. This mode allows multiple items in multiple PWM generators to be updated simultaneously without odd effects during the update; everything runs from the old values until a point at which they all run from the new values. The Update mode of the load and comparator match values can be individually configured in each PWM generator block. It typically makes sense to use the synchronous update mechanism across PWM generator blocks when the timers in those blocks are synchronized, although this is not required in order for this mechanism to function properly.

The following registers provide either local or global synchronization based on the state of various Update mode bits and fields in the **PWMnCTL** register (LOADUPD; CMPAUPD; CMPBUPD):

- Generator Registers: **PWMnLOAD**, **PWMnCMPA**, and **PWMnCMPB**

The following registers default to immediate update, but are provided with the optional functionality of synchronously updating rather than having all updates take immediate effect:

- Module-Level Register: **PWMENABLE** (based on the state of the ENUPDn bits in the PWMENUPD register).
- Generator Register: **PWMnGENA**, **PWMnGENB**, **PWMnDBCTL**, **PWMnDBRISE**, and **PWMnDBFALL** (based on the state of various Update mode bits and fields in the **PWMnCTL** register (GENAUPD; GENBUPD; DBCTLUPD; DBRISEUPD; DBFALLUPD)).

All other registers are considered statically provisioned for the execution of an application or are used dynamically for purposes unrelated to maintaining synchronization and therefore do not need synchronous update functionality.

19.3.7 Fault Conditions

A fault condition is one in which the controller must be signaled to stop normal PWM function and then set the M_nP_{WMn} signals to a safe state. Two basic situations cause fault conditions:

- The microcontroller is stalled and cannot perform the necessary computation in the time required for motion control
- An external error or event is detected

Each PWM generator can use the following inputs to generate a fault condition, including:

- $M_nFAULTn$ pin assertion
- A stall of the controller generated by the debugger
- The trigger of an ADC digital comparator

Fault conditions are calculated on a per-PWM generator basis. Each PWM generator configures the necessary conditions to indicate a fault condition exists. This method allows the development of applications with dependent and independent control.

Six fault input pins ($M_nFAULTn$) are available. These inputs may be used with circuits that generate an active High or active Low signal to indicate an error condition. A $M_nFAULTn$ pins may be individually programmed for the appropriate logic sense using the **PWMnFLTSEN** register.

The PWM generator's mode control, including fault condition handling, is provided in the **PWMnCTL** register. The **PWMnCTL** register also selects whether the fault condition is maintained as long as the external condition lasts or if it is latched until the fault condition until cleared by software. Finally, this register also enables a counter that may be used to extend the period of a fault condition for external events to assure that the duration is a minimum length. The minimum fault period count is specified in the **PWMnMINFLTPER** register.

Status regarding the specific fault cause is provided in the **PWMnFLTSTAT0** and **PWMnFLTSTAT1** registers.

PWM generator fault conditions may be promoted to a controller interrupt using the **PWMINTEN** register.

19.3.8 Output Control Block

The output control block takes care of the final conditioning of the pwmA' and pwmB' signals before they go to the pins as the M_nPWM_n signals. Via a single register, the **PWM Output Enable (PWENABLE)** register, the set of PWM signals that are actually enabled to the pins can be modified. This function can be used, for example, to perform commutation of a brushless DC motor with a single register write (and without modifying the individual PWM generators, which are modified by the feedback control loop). In addition, the updating of the bits in the **PWMENABLE** register can be configured to be immediate or locally or globally synchronized to the next synchronous update using the **PWM Enable Update (PWMENUUPD)** register.

During fault conditions, the PWM output signals, M_nPWM_n , usually must be driven to safe values so that external equipment may be safely controlled. The **PWMFAULT** register specifies whether during a fault condition, the generated signal continues to be passed driven or to an encoding specified in the **PWMFAULTVAL** register.

A final inversion can be applied to any of the M_nPWM_n signals, making them active Low instead of the default active High using the **PWM Output Inversion (PWMINVERT)**. The inversion is applied even if a value has been enabled in the **PWMFAULT** register and specified in the **PWMFAULTVAL** register. In other words, if a bit is set in the **PWMFAULT**, **PWMFAULTVAL**, and **PWMINVERT** registers, the output on the M_nPWM_n signal is 0, not 1 as specified in the **PWMFAULTVAL** register.

19.4 Initialization and Configuration

The following example shows how to initialize PWM Generator 0 with a 25-kHz frequency, a 25% duty cycle on the M_nPWM_0 pin, and a 75% duty cycle on the M_nPWM_1 pin. This example assumes the system clock is 20 MHz.

1. Enable the PWM clock by writing a value of 0x0010.0000 to the **RCGC0** register in the System Control module (see page 463).
2. Enable the clock to the appropriate GPIO module via the **RCGC2** register in the System Control module (see page 471).
3. In the GPIO module, enable the appropriate pins for their alternate function using the **GPIOAFSEL** register. To determine which GPIOs to configure, see Table 22-4 on page 1307.
4. Configure the PMC_n fields in the **GPIOPCTL** register to assign the PWM signals to the appropriate pins (see page 661 and Table 22-5 on page 1314).
5. Configure the **Run-Mode Clock Configuration (RCC)** register in the System Control module to use the PWM divide ($USEPWMDIV$) and set the divider ($PWMDIV$) to divide by 2 (000).
6. Configure the PWM generator for countdown mode with immediate updates to the parameters.
 - Write the **PWM0CTL** register with a value of 0x0000.0000.
 - Write the **PWM0GENA** register with a value of 0x0000.008C.
 - Write the **PWM0GENB** register with a value of 0x0000.080C.
7. Set the period. For a 25-KHz frequency, the period = 1/25,000, or 40 microseconds. The PWM clock source is 10 MHz; the system clock divided by 2. Thus there are 400 clock ticks per period. Use this value to set the **PWM0LOAD** register. In Count-Down mode, set the **LOAD** field in the **PWM0LOAD** register to the requested period minus one.

- Write the **PWM0LOAD** register with a value of 0x0000.018F.
8. Set the pulse width of the M_n PWM0 pin for a 25% duty cycle.
 - Write the **PWM0CMPA** register with a value of 0x0000.012B.
 9. Set the pulse width of the M_n PWM1 pin for a 75% duty cycle.
 - Write the **PWM0CMPB** register with a value of 0x0000.0063.
 10. Start the timers in PWM generator 0.
 - Write the **PWM0CTL** register with a value of 0x0000.0001.
 11. Enable PWM outputs.
 - Write the **PWMENABLE** register with a value of 0x0000.0003.

19.5 Register Map

Table 19-2 on page 1199 lists the PWM registers. The offset listed is a hexadecimal increment to the register's address, relative to the PWM module's base address:

- PWM0: 0x4002.8000
- PWM1: 0x4002.9000

Note that the PWM module clock must be enabled before the registers can be programmed (see page 463). There must be a delay of 3 system clocks after the PWM module clock is enabled before any PWM module registers are accessed.

Table 19-2. PWM Register Map

Offset	Name	Type	Reset	Description	See page
0x000	PWMCTL	R/W	0x0000.0000	PWM Master Control	1203
0x004	PWMSYNC	R/W	0x0000.0000	PWM Time Base Sync	1205
0x008	PWMENABLE	R/W	0x0000.0000	PWM Output Enable	1206
0x00C	PWMINVERT	R/W	0x0000.0000	PWM Output Inversion	1208
0x010	PWMFAULT	R/W	0x0000.0000	PWM Output Fault	1210
0x014	PWMINTEN	R/W	0x0000.0000	PWM Interrupt Enable	1212
0x018	PWMRIS	RO	0x0000.0000	PWM Raw Interrupt Status	1214
0x01C	PWMISC	R/W1C	0x0000.0000	PWM Interrupt Status and Clear	1217
0x020	PWMSTATUS	RO	0x0000.0000	PWM Status	1220
0x024	PWMFAULTVAL	R/W	0x0000.0000	PWM Fault Condition Value	1222
0x028	PWMENUPD	R/W	0x0000.0000	PWM Enable Update	1224
0x040	PWM0CTL	R/W	0x0000.0000	PWM0 Control	1228
0x044	PWM0INTEN	R/W	0x0000.0000	PWM0 Interrupt and Trigger Enable	1233

Table 19-2. PWM Register Map (continued)

Offset	Name	Type	Reset	Description	See page
0x048	PWM0RIS	RO	0x0000.0000	PWM0 Raw Interrupt Status	1236
0x04C	PWM0ISC	R/W1C	0x0000.0000	PWM0 Interrupt Status and Clear	1238
0x050	PWM0LOAD	R/W	0x0000.0000	PWM0 Load	1240
0x054	PWM0COUNT	RO	0x0000.0000	PWM0 Counter	1241
0x058	PWM0CMPA	R/W	0x0000.0000	PWM0 Compare A	1242
0x05C	PWM0CMPB	R/W	0x0000.0000	PWM0 Compare B	1243
0x060	PWM0GENA	R/W	0x0000.0000	PWM0 Generator A Control	1244
0x064	PWM0GENB	R/W	0x0000.0000	PWM0 Generator B Control	1247
0x068	PWM0DBCTL	R/W	0x0000.0000	PWM0 Dead-Band Control	1250
0x06C	PWM0DBRISE	R/W	0x0000.0000	PWM0 Dead-Band Rising-Edge Delay	1251
0x070	PWM0DBFALL	R/W	0x0000.0000	PWM0 Dead-Band Falling-Edge-Delay	1252
0x074	PWM0FLTSRC0	R/W	0x0000.0000	PWM0 Fault Source 0	1253
0x078	PWM0FLTSRC1	R/W	0x0000.0000	PWM0 Fault Source 1	1255
0x07C	PWM0MINFLTPER	R/W	0x0000.0000	PWM0 Minimum Fault Period	1258
0x080	PWM1CTL	R/W	0x0000.0000	PWM1 Control	1228
0x084	PWM1INTEN	R/W	0x0000.0000	PWM1 Interrupt and Trigger Enable	1233
0x088	PWM1RIS	RO	0x0000.0000	PWM1 Raw Interrupt Status	1236
0x08C	PWM1ISC	R/W1C	0x0000.0000	PWM1 Interrupt Status and Clear	1238
0x090	PWM1LOAD	R/W	0x0000.0000	PWM1 Load	1240
0x094	PWM1COUNT	RO	0x0000.0000	PWM1 Counter	1241
0x098	PWM1CMPA	R/W	0x0000.0000	PWM1 Compare A	1242
0x09C	PWM1CMPB	R/W	0x0000.0000	PWM1 Compare B	1243
0x0A0	PWM1GENA	R/W	0x0000.0000	PWM1 Generator A Control	1244
0x0A4	PWM1GENB	R/W	0x0000.0000	PWM1 Generator B Control	1247
0x0A8	PWM1DBCTL	R/W	0x0000.0000	PWM1 Dead-Band Control	1250
0x0AC	PWM1DBRISE	R/W	0x0000.0000	PWM1 Dead-Band Rising-Edge Delay	1251
0x0B0	PWM1DBFALL	R/W	0x0000.0000	PWM1 Dead-Band Falling-Edge-Delay	1252
0x0B4	PWM1FLTSRC0	R/W	0x0000.0000	PWM1 Fault Source 0	1253
0x0B8	PWM1FLTSRC1	R/W	0x0000.0000	PWM1 Fault Source 1	1255
0x0BC	PWM1MINFLTPER	R/W	0x0000.0000	PWM1 Minimum Fault Period	1258
0x0C0	PWM2CTL	R/W	0x0000.0000	PWM2 Control	1228
0x0C4	PWM2INTEN	R/W	0x0000.0000	PWM2 Interrupt and Trigger Enable	1233

Table 19-2. PWM Register Map (continued)

Offset	Name	Type	Reset	Description	See page
0x0C8	PWM2RIS	RO	0x0000.0000	PWM2 Raw Interrupt Status	1236
0x0CC	PWM2ISC	R/W1C	0x0000.0000	PWM2 Interrupt Status and Clear	1238
0x0D0	PWM2LOAD	R/W	0x0000.0000	PWM2 Load	1240
0x0D4	PWM2COUNT	RO	0x0000.0000	PWM2 Counter	1241
0x0D8	PWM2CMPA	R/W	0x0000.0000	PWM2 Compare A	1242
0x0DC	PWM2CMPB	R/W	0x0000.0000	PWM2 Compare B	1243
0x0E0	PWM2GENA	R/W	0x0000.0000	PWM2 Generator A Control	1244
0x0E4	PWM2GENB	R/W	0x0000.0000	PWM2 Generator B Control	1247
0x0E8	PWM2DBCTL	R/W	0x0000.0000	PWM2 Dead-Band Control	1250
0x0EC	PWM2DBRISE	R/W	0x0000.0000	PWM2 Dead-Band Rising-Edge Delay	1251
0x0F0	PWM2DBFALL	R/W	0x0000.0000	PWM2 Dead-Band Falling-Edge-Delay	1252
0x0F4	PWM2FLTSRC0	R/W	0x0000.0000	PWM2 Fault Source 0	1253
0x0F8	PWM2FLTSRC1	R/W	0x0000.0000	PWM2 Fault Source 1	1255
0x0FC	PWM2MINFLTPER	R/W	0x0000.0000	PWM2 Minimum Fault Period	1258
0x100	PWM3CTL	R/W	0x0000.0000	PWM3 Control	1228
0x104	PWM3INTEN	R/W	0x0000.0000	PWM3 Interrupt and Trigger Enable	1233
0x108	PWM3RIS	RO	0x0000.0000	PWM3 Raw Interrupt Status	1236
0x10C	PWM3ISC	R/W1C	0x0000.0000	PWM3 Interrupt Status and Clear	1238
0x110	PWM3LOAD	R/W	0x0000.0000	PWM3 Load	1240
0x114	PWM3COUNT	RO	0x0000.0000	PWM3 Counter	1241
0x118	PWM3CMPA	R/W	0x0000.0000	PWM3 Compare A	1242
0x11C	PWM3CMPB	R/W	0x0000.0000	PWM3 Compare B	1243
0x120	PWM3GENA	R/W	0x0000.0000	PWM3 Generator A Control	1244
0x124	PWM3GENB	R/W	0x0000.0000	PWM3 Generator B Control	1247
0x128	PWM3DBCTL	R/W	0x0000.0000	PWM3 Dead-Band Control	1250
0x12C	PWM3DBRISE	R/W	0x0000.0000	PWM3 Dead-Band Rising-Edge Delay	1251
0x130	PWM3DBFALL	R/W	0x0000.0000	PWM3 Dead-Band Falling-Edge-Delay	1252
0x134	PWM3FLTSRC0	R/W	0x0000.0000	PWM3 Fault Source 0	1253
0x138	PWM3FLTSRC1	R/W	0x0000.0000	PWM3 Fault Source 1	1255
0x13C	PWM3MINFLTPER	R/W	0x0000.0000	PWM3 Minimum Fault Period	1258
0x800	PWM0FLTSEN	R/W	0x0000.0000	PWM0 Fault Pin Logic Sense	1259
0x804	PWM0FLTSTAT0	-	0x0000.0000	PWM0 Fault Status 0	1260

Table 19-2. PWM Register Map (continued)

Offset	Name	Type	Reset	Description	See page
0x808	PWM0FLTSTAT1	-	0x0000.0000	PWM0 Fault Status 1	1262
0x880	PWM1FLTSEN	R/W	0x0000.0000	PWM1 Fault Pin Logic Sense	1259
0x884	PWM1FLTSTAT0	-	0x0000.0000	PWM1 Fault Status 0	1260
0x888	PWM1FLTSTAT1	-	0x0000.0000	PWM1 Fault Status 1	1262
0x900	PWM2FLTSEN	R/W	0x0000.0000	PWM2 Fault Pin Logic Sense	1259
0x904	PWM2FLTSTAT0	-	0x0000.0000	PWM2 Fault Status 0	1260
0x908	PWM2FLTSTAT1	-	0x0000.0000	PWM2 Fault Status 1	1262
0x980	PWM3FLTSEN	R/W	0x0000.0000	PWM3 Fault Pin Logic Sense	1259
0x984	PWM3FLTSTAT0	-	0x0000.0000	PWM3 Fault Status 0	1260
0x988	PWM3FLTSTAT1	-	0x0000.0000	PWM3 Fault Status 1	1262
0xFC0	PWMPP	RO	0x0000.0334	PWM Peripheral Properties	1265
0xFC4	PWMPC	R/W	0x0000.0000	PWM Peripheral Configuration	1267

19.6 Register Descriptions

The remainder of this section lists and describes the PWM registers, in numerical order by address offset.

Register 1: PWM Master Control (PWMCTL), offset 0x000

This register provides master control over the PWM generation blocks.

PWM Master Control (PWMCTL)

PWM0 base: 0x4002.8000

PWM1 base: 0x4002.9000

Offset 0x000

Type R/W, reset 0x0000.0000

	31	30	29	28	27	26	25	24	23	22	21	20	19	18	17	16	
	reserved																
Type	RO	RO	RO	RO	RO	RO	RO	RO	RO	RO	RO	RO	RO	RO	RO	RO	
Reset	0	0	0	0	0	0	0	0	0	0	0	0	0	0	0	0	
	15	14	13	12	11	10	9	8	7	6	5	4	3	2	1	0	
	reserved												GLOBALSYNC3	GLOBALSYNC2	GLOBALSYNC1	GLOBALSYNC0	
Type	RO	RO	RO	RO	RO	RO	RO	RO	RO	RO	RO	RO	RO	R/W	R/W	R/W	R/W
Reset	0	0	0	0	0	0	0	0	0	0	0	0	0	0	0	0	0

Bit/Field	Name	Type	Reset	Description
31:4	reserved	RO	0x0000	Software should not rely on the value of a reserved bit. To provide compatibility with future products, the value of a reserved bit should be preserved across a read-modify-write operation.
3	GLOBALSYNC3	R/W	0	Update PWM Generator 3 Value Description 1 Any queued update to a load or comparator register in PWM generator 3 is applied the next time the corresponding counter becomes zero. 0 No effect. This bit automatically clears when the updates have completed; it cannot be cleared by software.
2	GLOBALSYNC2	R/W	0	Update PWM Generator 2 Value Description 1 Any queued update to a load or comparator register in PWM generator 2 is applied the next time the corresponding counter becomes zero. 0 No effect. This bit automatically clears when the updates have completed; it cannot be cleared by software.
1	GLOBALSYNC1	R/W	0	Update PWM Generator 1 Value Description 1 Any queued update to a load or comparator register in PWM generator 1 is applied the next time the corresponding counter becomes zero. 0 No effect. This bit automatically clears when the updates have completed; it cannot be cleared by software.

Bit/Field	Name	Type	Reset	Description
0	GLOBALSYNC0	R/W	0	Update PWM Generator 0
				Value Description
			1	Any queued update to a load or comparator register in PWM generator 0 is applied the next time the corresponding counter becomes zero.
			0	No effect.
				This bit automatically clears when the updates have completed; it cannot be cleared by software.

Register 2: PWM Time Base Sync (PWMSYNC), offset 0x004

This register provides a method to perform synchronization of the counters in the PWM generation blocks. Setting a bit in this register causes the specified counter to reset back to 0; setting multiple bits resets multiple counters simultaneously. The bits auto-clear after the reset has occurred; reading them back as zero indicates that the synchronization has completed.

PWM Time Base Sync (PWMSYNC)

PWM0 base: 0x4002.8000
 PWM1 base: 0x4002.9000
 Offset 0x004
 Type R/W, reset 0x0000.0000

	31	30	29	28	27	26	25	24	23	22	21	20	19	18	17	16	
	reserved																
Type	RO	RO	RO	RO	RO	RO	RO	RO	RO	RO	RO	RO	RO	RO	RO	RO	
Reset	0	0	0	0	0	0	0	0	0	0	0	0	0	0	0	0	
	15	14	13	12	11	10	9	8	7	6	5	4	3	2	1	0	
	reserved												SYNC3	SYNC2	SYNC1	SYNC0	
Type	RO	RO	RO	RO	RO	RO	RO	RO	RO	RO	RO	RO	RO	R/W	R/W	R/W	R/W
Reset	0	0	0	0	0	0	0	0	0	0	0	0	0	0	0	0	0

Bit/Field	Name	Type	Reset	Description
31:4	reserved	RO	0x0000.000	Software should not rely on the value of a reserved bit. To provide compatibility with future products, the value of a reserved bit should be preserved across a read-modify-write operation.
3	SYNC3	R/W	0	Reset Generator 3 Counter Value Description 1 Resets the PWM generator 3 counter. 0 No effect.
2	SYNC2	R/W	0	Reset Generator 2 Counter Value Description 1 Resets the PWM generator 2 counter. 0 No effect.
1	SYNC1	R/W	0	Reset Generator 1 Counter Value Description 1 Resets the PWM generator 1 counter. 0 No effect.
0	SYNC0	R/W	0	Reset Generator 0 Counter Value Description 1 Resets the PWM generator 0 counter. 0 No effect.

Register 3: PWM Output Enable (PWMENTABLE), offset 0x008

This register provides a master control of which generated pwmA' and pwmB' signals are output to the M_nPwM_n pins. By disabling a PWM output, the generation process can continue (for example, when the time bases are synchronized) without driving PWM signals to the pins. When bits in this register are set, the corresponding pwmA' or pwmB' signal is passed through to the output stage. When bits are clear, the pwmA' or pwmB' signal is replaced by a zero value which is also passed to the output stage. The **PWMINVERT** register controls the output stage, so if the corresponding bit is set in that register, the value seen on the M_nPwM_n signal is inverted from what is configured by the bits in this register. Updates to the bits in this register can be immediate or locally or globally synchronized to the next synchronous update as controlled by the $ENUPD_n$ fields in the **PWMENUPD** register.

PWM Output Enable (PWMENTABLE)

PWM0 base: 0x4002.8000
 PWM1 base: 0x4002.9000
 Offset 0x008
 Type R/W, reset 0x0000.0000

	31	30	29	28	27	26	25	24	23	22	21	20	19	18	17	16
	reserved															
Type	RO	RO	RO	RO	RO	RO	RO	RO	RO	RO	RO	RO	RO	RO	RO	RO
Reset	0	0	0	0	0	0	0	0	0	0	0	0	0	0	0	0
	15	14	13	12	11	10	9	8	7	6	5	4	3	2	1	0
	reserved								PWM7EN	PWM6EN	PWM5EN	PWM4EN	PWM3EN	PWM2EN	PWM1EN	PWM0EN
Type	RO	RO	RO	RO	RO	RO	RO	RO	R/W	R/W	R/W	R/W	R/W	R/W	R/W	R/W
Reset	0	0	0	0	0	0	0	0	0	0	0	0	0	0	0	0

Bit/Field	Name	Type	Reset	Description
31:8	reserved	RO	0x0000.00	Software should not rely on the value of a reserved bit. To provide compatibility with future products, the value of a reserved bit should be preserved across a read-modify-write operation.
7	PWM7EN	R/W	0	M_nPwM_7 Output Enable Value Description 1 The generated pwm3B' signal is passed to the M_nPwM_7 pin. 0 The M_nPwM_7 signal has a zero value.
6	PWM6EN	R/W	0	M_nPwM_6 Output Enable Value Description 1 The generated pwm3A' signal is passed to the M_nPwM_6 pin. 0 The M_nPwM_6 signal has a zero value.
5	PWM5EN	R/W	0	M_nPwM_5 Output Enable Value Description 1 The generated pwm2B' signal is passed to the M_nPwM_5 pin. 0 The M_nPwM_5 signal has a zero value.

Bit/Field	Name	Type	Reset	Description
4	PWM4EN	R/W	0	MnPWM4 Output Enable Value Description 1 The generated pwm2A' signal is passed to the MnPWM4 pin. 0 The MnPWM4 signal has a zero value.
3	PWM3EN	R/W	0	MnPWM3 Output Enable Value Description 1 The generated pwm1B' signal is passed to the MnPWM3 pin. 0 The MnPWM3 signal has a zero value.
2	PWM2EN	R/W	0	MnPWM2 Output Enable Value Description 1 The generated pwm1A' signal is passed to the MnPWM2 pin. 0 The MnPWM2 signal has a zero value.
1	PWM1EN	R/W	0	MnPWM1 Output Enable Value Description 1 The generated pwm0B' signal is passed to the MnPWM1 pin. 0 The MnPWM1 signal has a zero value.
0	PWM0EN	R/W	0	MnPWM0 Output Enable Value Description 1 The generated pwm0A' signal is passed to the MnPWM0 pin. 0 The MnPWM0 signal has a zero value.

Register 4: PWM Output Inversion (PWMINVERT), offset 0x00C

This register provides a master control of the polarity of the M_nPWM_n signals on the device pins. The $pwmA'$ and $pwmB'$ signals generated by the PWM generator are active High; but can be made active Low via this register. Disabled PWM channels are also passed through the output inverter (if so configured) so that inactive signals can be High. In addition, if the **PWMFAULT** register enables a specific value to be placed on the M_nPWM_n signals during a fault condition, that value is inverted if the corresponding bit in this register is set.

PWM Output Inversion (PWMINVERT)

PWM0 base: 0x4002.8000
 PWM1 base: 0x4002.9000
 Offset 0x00C
 Type R/W, reset 0x0000.0000

	31	30	29	28	27	26	25	24	23	22	21	20	19	18	17	16
	reserved															
Type	RO	RO	RO	RO	RO	RO	RO	RO	RO	RO	RO	RO	RO	RO	RO	RO
Reset	0	0	0	0	0	0	0	0	0	0	0	0	0	0	0	0
	15	14	13	12	11	10	9	8	7	6	5	4	3	2	1	0
	reserved								PWM7INV	PWM6INV	PWM5INV	PWM4INV	PWM3INV	PWM2INV	PWM1INV	PWM0INV
Type	RO	RO	RO	RO	RO	RO	RO	RO	R/W	R/W	R/W	R/W	R/W	R/W	R/W	R/W
Reset	0	0	0	0	0	0	0	0	0	0	0	0	0	0	0	0

Bit/Field	Name	Type	Reset	Description
31:8	reserved	RO	0x0000.00	Software should not rely on the value of a reserved bit. To provide compatibility with future products, the value of a reserved bit should be preserved across a read-modify-write operation.
7	PWM7INV	R/W	0	Invert M_nPWM_7 Signal Value Description 1 The M_nPWM_7 signal is inverted. 0 The M_nPWM_7 signal is not inverted.
6	PWM6INV	R/W	0	Invert M_nPWM_6 Signal Value Description 1 The M_nPWM_6 signal is inverted. 0 The M_nPWM_6 signal is not inverted.
5	PWM5INV	R/W	0	Invert M_nPWM_5 Signal Value Description 1 The M_nPWM_5 signal is inverted. 0 The M_nPWM_5 signal is not inverted.
4	PWM4INV	R/W	0	Invert M_nPWM_4 Signal Value Description 1 The M_nPWM_4 signal is inverted. 0 The M_nPWM_4 signal is not inverted.

Bit/Field	Name	Type	Reset	Description
3	PWM3INV	R/W	0	Invert M _n PWM3 Signal Value Description 1 The M _n PWM3 signal is inverted. 0 The M _n PWM3 signal is not inverted.
2	PWM2INV	R/W	0	Invert M _n PWM2 Signal Value Description 1 The M _n PWM2 signal is inverted. 0 The M _n PWM2 signal is not inverted.
1	PWM1INV	R/W	0	Invert M _n PWM1 Signal Value Description 1 The M _n PWM1 signal is inverted. 0 The M _n PWM1 signal is not inverted.
0	PWM0INV	R/W	0	Invert M _n PWM0 Signal Value Description 1 The M _n PWM0 signal is inverted. 0 The M _n PWM0 signal is not inverted.

Register 5: PWM Output Fault (PWMFAULT), offset 0x010

This register controls the behavior of the M_nP_{WMn} outputs in the presence of fault conditions. Both the fault inputs (M_nFAULT_n pins and digital comparator outputs) and debug events are considered fault conditions. On a fault condition, each pwmA' or pwmB' signal can be passed through unmodified or driven to the value specified by the corresponding bit in the **PWMFAULTVAL** register. For outputs that are configured for pass-through, the debug event handling on the corresponding PWM generator also determines if the pwmA' or pwmB' signal continues to be generated.

Fault condition control occurs before the output inverter, so PWM signals driven to a specified value on fault are inverted if the channel is configured for inversion (therefore, the pin is driven to the logical complement of the specified value on a fault condition).

PWM Output Fault (PWMFAULT)

PWM0 base: 0x4002.8000
 PWM1 base: 0x4002.9000
 Offset 0x010
 Type R/W, reset 0x0000.0000

	31	30	29	28	27	26	25	24	23	22	21	20	19	18	17	16
	reserved															
Type	RO	RO	RO	RO	RO	RO	RO	RO	RO	RO	RO	RO	RO	RO	RO	RO
Reset	0	0	0	0	0	0	0	0	0	0	0	0	0	0	0	0
	15	14	13	12	11	10	9	8	7	6	5	4	3	2	1	0
	reserved								FAULT7	FAULT6	FAULT5	FAULT4	FAULT3	FAULT2	FAULT1	FAULT0
Type	RO	RO	RO	RO	RO	RO	RO	RO	R/W	R/W	R/W	R/W	R/W	R/W	R/W	R/W
Reset	0	0	0	0	0	0	0	0	0	0	0	0	0	0	0	0

Bit/Field	Name	Type	Reset	Description
31:8	reserved	RO	0x0000.00	Software should not rely on the value of a reserved bit. To provide compatibility with future products, the value of a reserved bit should be preserved across a read-modify-write operation.
7	FAULT7	R/W	0	<p>M_nP_{WM7} Fault</p> <p>Value Description</p> <p>1 The M_nP_{WM7} output signal is driven to the value specified by the P_{WM7} bit in the PWMFAULTVAL register.</p> <p>0 The generated pwm3B' signal is passed to the M_nP_{WM7} pin.</p>
6	FAULT6	R/W	0	<p>M_nP_{WM6} Fault</p> <p>Value Description</p> <p>1 The M_nP_{WM6} output signal is driven to the value specified by the P_{WM6} bit in the PWMFAULTVAL register.</p> <p>0 The generated pwm3A' signal is passed to the M_nP_{WM6} pin.</p>
5	FAULT5	R/W	0	<p>M_nP_{WM5} Fault</p> <p>Value Description</p> <p>1 The M_nP_{WM5} output signal is driven to the value specified by the P_{WM5} bit in the PWMFAULTVAL register.</p> <p>0 The generated pwm2B' signal is passed to the M_nP_{WM5} pin.</p>

Bit/Field	Name	Type	Reset	Description
4	FAULT4	R/W	0	<p>MnPWM4 Fault</p> <p>Value Description</p> <p>1 The MnPWM4 output signal is driven to the value specified by the PWM4 bit in the PWMFAULTVAL register.</p> <p>0 The generated pwm2A' signal is passed to the MnPWM4 pin.</p>
3	FAULT3	R/W	0	<p>MnPWM3 Fault</p> <p>Value Description</p> <p>1 The MnPWM3 output signal is driven to the value specified by the PWM3 bit in the PWMFAULTVAL register.</p> <p>0 The generated pwm1B' signal is passed to the MnPWM3 pin.</p>
2	FAULT2	R/W	0	<p>MnPWM2 Fault</p> <p>Value Description</p> <p>1 The MnPWM2 output signal is driven to the value specified by the PWM2 bit in the PWMFAULTVAL register.</p> <p>0 The generated pwm1A' signal is passed to the MnPWM2 pin.</p>
1	FAULT1	R/W	0	<p>MnPWM1 Fault</p> <p>Value Description</p> <p>1 The MnPWM1 output signal is driven to the value specified by the PWM1 bit in the PWMFAULTVAL register.</p> <p>0 The generated pwm0B' signal is passed to the MnPWM1 pin.</p>
0	FAULT0	R/W	0	<p>MnPWM0 Fault</p> <p>Value Description</p> <p>1 The MnPWM0 output signal is driven to the value specified by the PWM0 bit in the PWMFAULTVAL register.</p> <p>0 The generated pwm0A' signal is passed to the MnPWM0 pin.</p>

Register 6: PWM Interrupt Enable (PWMINTEN), offset 0x014

This register controls the global interrupt generation capabilities of the PWM module. The events that can cause an interrupt are the fault input and the individual interrupts from the PWM generators.

Note: The "n" in the INTFAULT_n and INTPWM_n bits in this register correspond to the PWM generators, not to the FAULT_n signals.

PWM Interrupt Enable (PWMINTEN)

PWM0 base: 0x4002.8000
 PWM1 base: 0x4002.9000
 Offset 0x014
 Type R/W, reset 0x0000.0000

	31	30	29	28	27	26	25	24	23	22	21	20	19	18	17	16
	reserved												INTFAULT3	INTFAULT2	INTFAULT1	INTFAULT0
Type	RO	RO	RO	RO	RO	RO	RO	RO	RO	RO	RO	RO	R/W	R/W	R/W	R/W
Reset	0	0	0	0	0	0	0	0	0	0	0	0	0	0	0	0
	15	14	13	12	11	10	9	8	7	6	5	4	3	2	1	0
	reserved												INTPWM3	INTPWM2	INTPWM1	INTPWM0
Type	RO	RO	RO	RO	RO	RO	RO	RO	RO	RO	RO	RO	R/W	R/W	R/W	R/W
Reset	0	0	0	0	0	0	0	0	0	0	0	0	0	0	0	0

Bit/Field	Name	Type	Reset	Description
31:20	reserved	RO	0x000	Software should not rely on the value of a reserved bit. To provide compatibility with future products, the value of a reserved bit should be preserved across a read-modify-write operation.
19	INTFAULT3	R/W	0	Interrupt Fault 3 Value Description 1 An interrupt is sent to the interrupt controller when the fault condition for PWM generator 3 is asserted. 0 The fault condition for PWM generator 3 is suppressed and not sent to the interrupt controller.
18	INTFAULT2	R/W	0	Interrupt Fault 2 Value Description 1 An interrupt is sent to the interrupt controller when the fault condition for PWM generator 2 is asserted. 0 The fault condition for PWM generator 2 is suppressed and not sent to the interrupt controller.
17	INTFAULT1	R/W	0	Interrupt Fault 1 Value Description 1 An interrupt is sent to the interrupt controller when the fault condition for PWM generator 1 is asserted. 0 The fault condition for PWM generator 1 is suppressed and not sent to the interrupt controller.

Bit/Field	Name	Type	Reset	Description
16	INTFAULT0	R/W	0	<p>Interrupt Fault 0</p> <p>Value Description</p> <p>1 An interrupt is sent to the interrupt controller when the fault condition for PWM generator 0 is asserted.</p> <p>0 The fault condition for PWM generator 0 is suppressed and not sent to the interrupt controller.</p>
15:4	reserved	RO	0x000	Software should not rely on the value of a reserved bit. To provide compatibility with future products, the value of a reserved bit should be preserved across a read-modify-write operation.
3	INTPWM3	R/W	0	<p>PWM3 Interrupt Enable</p> <p>Value Description</p> <p>1 An interrupt is sent to the interrupt controller when the PWM generator 3 block asserts an interrupt.</p> <p>0 The PWM generator 3 interrupt is suppressed and not sent to the interrupt controller.</p>
2	INTPWM2	R/W	0	<p>PWM2 Interrupt Enable</p> <p>Value Description</p> <p>1 An interrupt is sent to the interrupt controller when the PWM generator 2 block asserts an interrupt.</p> <p>0 The PWM generator 2 interrupt is suppressed and not sent to the interrupt controller.</p>
1	INTPWM1	R/W	0	<p>PWM1 Interrupt Enable</p> <p>Value Description</p> <p>1 An interrupt is sent to the interrupt controller when the PWM generator 1 block asserts an interrupt.</p> <p>0 The PWM generator 1 interrupt is suppressed and not sent to the interrupt controller.</p>
0	INTPWM0	R/W	0	<p>PWM0 Interrupt Enable</p> <p>Value Description</p> <p>1 An interrupt is sent to the interrupt controller when the PWM generator 0 block asserts an interrupt.</p> <p>0 The PWM generator 0 interrupt is suppressed and not sent to the interrupt controller.</p>

Register 7: PWM Raw Interrupt Status (PWMRIS), offset 0x018

This register provides the current set of interrupt sources that are asserted, regardless of whether they are enabled to cause an interrupt to be asserted to the interrupt controller. The fault interrupt is asserted based on the fault condition source that is specified by the **PWMnCTL**, **PWMnFLTSRC0** and **PWMnFLTSRC1** registers. The fault interrupt is latched on detection and must be cleared through the **PWM Interrupt Status and Clear (PWMISC)** register. The actual value of the $M_nFAULTn$ signals can be observed using the **PWMSTATUS** register.

The PWM generator interrupts simply reflect the status of the PWM generators and are cleared via the interrupt status register in the PWM generator blocks. If a bit is set, the event is active; if a bit is clear the event is not active.

PWM Raw Interrupt Status (PWMRIS)

PWM0 base: 0x4002.8000
 PWM1 base: 0x4002.9000
 Offset 0x018
 Type RO, reset 0x0000.0000

	31	30	29	28	27	26	25	24	23	22	21	20	19	18	17	16
	reserved												INTFAULT3	INTFAULT2	INTFAULT1	INTFAULT0
Type	RO	RO	RO	RO	RO	RO	RO	RO	RO	RO	RO	RO	RO	RO	RO	RO
Reset	0	0	0	0	0	0	0	0	0	0	0	0	0	0	0	0
	15	14	13	12	11	10	9	8	7	6	5	4	3	2	1	0
	reserved												INTPWM3	INTPWM2	INTPWM1	INTPWM0
Type	RO	RO	RO	RO	RO	RO	RO	RO	RO	RO	RO	RO	RO	RO	RO	RO
Reset	0	0	0	0	0	0	0	0	0	0	0	0	0	0	0	0

Bit/Field	Name	Type	Reset	Description
31:20	reserved	RO	0x000	Software should not rely on the value of a reserved bit. To provide compatibility with future products, the value of a reserved bit should be preserved across a read-modify-write operation.
19	INTFAULT3	RO	0	Interrupt Fault PWM 3 Value Description 1 The fault condition for PWM generator 3 is asserted. 0 The fault condition for PWM generator 3 has not been asserted. This bit is cleared by writing a 1 to the INTFAULT3 bit in the PWMISC register.
18	INTFAULT2	RO	0	Interrupt Fault PWM 2 Value Description 1 The fault condition for PWM generator 2 is asserted. 0 The fault condition for PWM generator 2 has not been asserted. This bit is cleared by writing a 1 to the INTFAULT2 bit in the PWMISC register.

Bit/Field	Name	Type	Reset	Description
17	INTFAULT1	RO	0	<p>Interrupt Fault PWM 1</p> <p>Value Description</p> <p>1 The fault condition for PWM generator 1 is asserted.</p> <p>0 The fault condition for PWM generator 1 has not been asserted.</p> <p>This bit is cleared by writing a 1 to the INTFAULT1 bit in the PWMISC register.</p>
16	INTFAULT0	RO	0	<p>Interrupt Fault PWM 0</p> <p>Value Description</p> <p>1 The fault condition for PWM generator 0 is asserted.</p> <p>0 The fault condition for PWM generator 0 has not been asserted.</p> <p>This bit is cleared by writing a 1 to the INTFAULT0 bit in the PWMISC register.</p>
15:4	reserved	RO	0x000	Software should not rely on the value of a reserved bit. To provide compatibility with future products, the value of a reserved bit should be preserved across a read-modify-write operation.
3	INTPWM3	RO	0	<p>PWM3 Interrupt Asserted</p> <p>Value Description</p> <p>1 The PWM generator 3 block interrupt is asserted.</p> <p>0 The PWM generator 3 block interrupt has not been asserted.</p> <p>The PWM3RIS register shows the source of this interrupt. This bit is cleared by writing a 1 to the corresponding bit in the PWM3ISC register.</p>
2	INTPWM2	RO	0	<p>PWM2 Interrupt Asserted</p> <p>Value Description</p> <p>1 The PWM generator 2 block interrupt is asserted.</p> <p>0 The PWM generator 2 block interrupt has not been asserted.</p> <p>The PWM2RIS register shows the source of this interrupt. This bit is cleared by writing a 1 to the corresponding bit in the PWM2ISC register.</p>
1	INTPWM1	RO	0	<p>PWM1 Interrupt Asserted</p> <p>Value Description</p> <p>1 The PWM generator 1 block interrupt is asserted.</p> <p>0 The PWM generator 1 block interrupt has not been asserted.</p> <p>The PWM1RIS register shows the source of this interrupt. This bit is cleared by writing a 1 to the corresponding bit in the PWM1ISC register.</p>

Bit/Field	Name	Type	Reset	Description
0	INTPWM0	RO	0	PWM0 Interrupt Asserted

Value Description

1 The PWM generator 0 block interrupt is asserted.

0 The PWM generator 0 block interrupt has not been asserted.

The **PWM0RIS** register shows the source of this interrupt. This bit is cleared by writing a 1 to the corresponding bit in the **PWM0ISC** register.

Register 8: PWM Interrupt Status and Clear (PWMISC), offset 0x01C

This register provides a summary of the interrupt status of the individual PWM generator blocks. If a fault interrupt is set, the corresponding $M_nFAULTn$ input has caused an interrupt. For the fault interrupt, a write of 1 to that bit position clears the latched interrupt status. If an block interrupt bit is set, the corresponding generator block is asserting an interrupt. The individual interrupt status registers, **PWMnISC**, in each block must be consulted to determine the reason for the interrupt and used to clear the interrupt.

PWM Interrupt Status and Clear (PWMISC)

PWM0 base: 0x4002.8000
 PWM1 base: 0x4002.9000
 Offset 0x01C
 Type R/W1C, reset 0x0000.0000

	31	30	29	28	27	26	25	24	23	22	21	20	19	18	17	16
	reserved												INTFAULT3	INTFAULT2	INTFAULT1	INTFAULT0
Type	RO	RO	RO	RO	RO	RO	RO	RO	RO	RO	RO	RO	R/W1C	R/W1C	R/W1C	R/W1C
Reset	0	0	0	0	0	0	0	0	0	0	0	0	0	0	0	0
	15	14	13	12	11	10	9	8	7	6	5	4	3	2	1	0
	reserved												INTPWM3	INTPWM2	INTPWM1	INTPWM0
Type	RO	RO	RO	RO	RO	RO	RO	RO	RO	RO	RO	RO	RO	RO	RO	RO
Reset	0	0	0	0	0	0	0	0	0	0	0	0	0	0	0	0

Bit/Field	Name	Type	Reset	Description
31:20	reserved	RO	0x000	Software should not rely on the value of a reserved bit. To provide compatibility with future products, the value of a reserved bit should be preserved across a read-modify-write operation.
19	INTFAULT3	R/W1C	0	FAULT3 Interrupt Asserted Value Description 1 An enabled interrupt for the fault condition for PWM generator 3 is asserted or is latched. 0 The fault condition for PWM generator 3 has not been asserted or is not enabled. Writing a 1 to this bit clears it and the <code>INTFAULT3</code> bit in the PWMRIS register.
18	INTFAULT2	R/W1C	0	FAULT2 Interrupt Asserted Value Description 1 An enabled interrupt for the fault condition for PWM generator 2 is asserted or is latched. 0 The fault condition for PWM generator 2 has not been asserted or is not enabled. Writing a 1 to this bit clears it and the <code>INTFAULT2</code> bit in the PWMRIS register.

Bit/Field	Name	Type	Reset	Description
17	INTFAULT1	R/W1C	0	<p>FAULT1 Interrupt Asserted</p> <p>Value Description</p> <p>1 An enabled interrupt for the fault condition for PWM generator 1 is asserted or is latched.</p> <p>0 The fault condition for PWM generator 1 has not been asserted or is not enabled.</p> <p>Writing a 1 to this bit clears it and the INTFAULT1 bit in the PWMRIS register.</p>
16	INTFAULT0	R/W1C	0	<p>FAULT0 Interrupt Asserted</p> <p>Value Description</p> <p>1 An enabled interrupt for the fault condition for PWM generator 0 is asserted or is latched.</p> <p>0 The fault condition for PWM generator 0 has not been asserted or is not enabled.</p> <p>Writing a 1 to this bit clears it and the INTFAULT0 bit in the PWMRIS register.</p>
15:4	reserved	RO	0x000	Software should not rely on the value of a reserved bit. To provide compatibility with future products, the value of a reserved bit should be preserved across a read-modify-write operation.
3	INTPWM3	RO	0	<p>PWM3 Interrupt Status</p> <p>Value Description</p> <p>1 An enabled interrupt for the PWM generator 3 block is asserted.</p> <p>0 The PWM generator 3 block interrupt is not asserted or is not enabled.</p> <p>The PWM3RIS register shows the source of this interrupt. This bit is cleared by writing a 1 to the corresponding bit in the PWM3ISC register.</p>
2	INTPWM2	RO	0	<p>PWM2 Interrupt Status</p> <p>Value Description</p> <p>1 An enabled interrupt for the PWM generator 2 block is asserted.</p> <p>0 The PWM generator 2 block interrupt is not asserted or is not enabled.</p> <p>The PWM2RIS register shows the source of this interrupt. This bit is cleared by writing a 1 to the corresponding bit in the PWM2ISC register.</p>
1	INTPWM1	RO	0	<p>PWM1 Interrupt Status</p> <p>Value Description</p> <p>1 An enabled interrupt for the PWM generator 1 block is asserted.</p> <p>0 The PWM generator 1 block interrupt is not asserted or is not enabled.</p> <p>The PWM1RIS register shows the source of this interrupt. This bit is cleared by writing a 1 to the corresponding bit in the PWM1ISC register.</p>

Bit/Field	Name	Type	Reset	Description
0	INTPWM0	RO	0	PWM0 Interrupt Status
				Value Description
				1 An enabled interrupt for the PWM generator 0 block is asserted.
				0 The PWM generator 0 block interrupt is not asserted or is not enabled.

The **PWM0RIS** register shows the source of this interrupt. This bit is cleared by writing a 1 to the corresponding bit in the **PWM0ISC** register.

Register 9: PWM Status (PWMSTATUS), offset 0x020

This register provides the unlatched status of the PWM generator fault condition.

PWM Status (PWMSTATUS)

PWM0 base: 0x4002.8000

PWM1 base: 0x4002.9000

Offset 0x020

Type RO, reset 0x0000.0000

	31	30	29	28	27	26	25	24	23	22	21	20	19	18	17	16
	reserved															
Type	RO	RO	RO	RO	RO	RO	RO	RO	RO	RO	RO	RO	RO	RO	RO	RO
Reset	0	0	0	0	0	0	0	0	0	0	0	0	0	0	0	0
	15	14	13	12	11	10	9	8	7	6	5	4	3	2	1	0
	reserved												FAULT3	FAULT2	FAULT1	FAULT0
Type	RO	RO	RO	RO	RO	RO	RO	RO	RO	RO	RO	RO	RO	RO	RO	RO
Reset	0	0	0	0	0	0	0	0	0	0	0	0	0	0	0	0

Bit/Field	Name	Type	Reset	Description
31:4	reserved	RO	0x0000.000	Software should not rely on the value of a reserved bit. To provide compatibility with future products, the value of a reserved bit should be preserved across a read-modify-write operation.
3	FAULT3	RO	0	Generator 3 Fault Status Value Description 1 The fault condition for PWM generator 3 is asserted. If the FLTSRC bit in the PWM3CTL register is clear, the input is the source of the fault condition, and is therefore asserted. 0 The fault condition for PWM generator 3 is not asserted.
2	FAULT2	RO	0	Generator 2 Fault Status Value Description 1 The fault condition for PWM generator 2 is asserted. If the FLTSRC bit in the PWM2CTL register is clear, the input is the source of the fault condition, and is therefore asserted. 0 The fault condition for PWM generator 2 is not asserted.
1	FAULT1	RO	0	Generator 1 Fault Status Value Description 1 The fault condition for PWM generator 1 is asserted. If the FLTSRC bit in the PWM1CTL register is clear, the input is the source of the fault condition, and is therefore asserted. 0 The fault condition for PWM generator 1 is not asserted.

Bit/Field	Name	Type	Reset	Description
0	FAULT0	RO	0	Generator 0 Fault Status
				Value Description
				1 The fault condition for PWM generator 0 is asserted. If the <code>FLTSRC</code> bit in the <code>PWM0CTL</code> register is clear, the input is the source of the fault condition, and is therefore asserted.
				0 The fault condition for PWM generator 0 is not asserted.

Register 10: PWM Fault Condition Value (PWMFAULTVAL), offset 0x024

This register specifies the output value driven on the M_nPWM_n signals during a fault condition if enabled by the corresponding bit in the **PWMFAULT** register. Note that if the corresponding bit in the **PWMINVERT** register is set, the output value is driven to the logical NOT of the bit value in this register.

PWM Fault Condition Value (PWMFAULTVAL)

PWM0 base: 0x4002.8000
 PWM1 base: 0x4002.9000
 Offset 0x024
 Type R/W, reset 0x0000.0000

	31	30	29	28	27	26	25	24	23	22	21	20	19	18	17	16
	reserved															
Type	RO	RO	RO	RO	RO	RO	RO	RO	RO	RO	RO	RO	RO	RO	RO	RO
Reset	0	0	0	0	0	0	0	0	0	0	0	0	0	0	0	0
	15	14	13	12	11	10	9	8	7	6	5	4	3	2	1	0
	reserved								PWM7	PWM6	PWM5	PWM4	PWM3	PWM2	PWM1	PWM0
Type	RO	RO	RO	RO	RO	RO	RO	RO	R/W	R/W	R/W	R/W	R/W	R/W	R/W	R/W
Reset	0	0	0	0	0	0	0	0	0	0	0	0	0	0	0	0

Bit/Field	Name	Type	Reset	Description
31:8	reserved	RO	0x0000.00	Software should not rely on the value of a reserved bit. To provide compatibility with future products, the value of a reserved bit should be preserved across a read-modify-write operation.
7	PWM7	R/W	0	<p>M_nPWM_7 Fault Value</p> <p>Value Description</p> <p>1 The M_nPWM_7 output signal is driven High during fault conditions if the FAULT7 bit in the PWMFAULT register is set.</p> <p>0 The M_nPWM_7 output signal is driven Low during fault conditions if the FAULT7 bit in the PWMFAULT register is set.</p>
6	PWM6	R/W	0	<p>M_nPWM_6 Fault Value</p> <p>Value Description</p> <p>1 The M_nPWM_6 output signal is driven High during fault conditions if the FAULT6 bit in the PWMFAULT register is set.</p> <p>0 The M_nPWM_6 output signal is driven Low during fault conditions if the FAULT6 bit in the PWMFAULT register is set.</p>
5	PWM5	R/W	0	<p>M_nPWM_5 Fault Value</p> <p>Value Description</p> <p>1 The M_nPWM_5 output signal is driven High during fault conditions if the FAULT5 bit in the PWMFAULT register is set.</p> <p>0 The M_nPWM_5 output signal is driven Low during fault conditions if the FAULT5 bit in the PWMFAULT register is set.</p>

Bit/Field	Name	Type	Reset	Description
4	PWM4	R/W	0	<p>MnPWM4 Fault Value</p> <p>Value Description</p> <p>1 The MnPWM4 output signal is driven High during fault conditions if the FAULT4 bit in the PWMFAULT register is set.</p> <p>0 The MnPWM4 output signal is driven Low during fault conditions if the FAULT4 bit in the PWMFAULT register is set.</p>
3	PWM3	R/W	0	<p>MnPWM3 Fault Value</p> <p>Value Description</p> <p>1 The MnPWM3 output signal is driven High during fault conditions if the FAULT3 bit in the PWMFAULT register is set.</p> <p>0 The MnPWM3 output signal is driven Low during fault conditions if the FAULT3 bit in the PWMFAULT register is set.</p>
2	PWM2	R/W	0	<p>MnPWM2 Fault Value</p> <p>Value Description</p> <p>1 The MnPWM2 output signal is driven High during fault conditions if the FAULT2 bit in the PWMFAULT register is set.</p> <p>0 The MnPWM2 output signal is driven Low during fault conditions if the FAULT2 bit in the PWMFAULT register is set.</p>
1	PWM1	R/W	0	<p>MnPWM1 Fault Value</p> <p>Value Description</p> <p>1 The MnPWM1 output signal is driven High during fault conditions if the FAULT1 bit in the PWMFAULT register is set.</p> <p>0 The MnPWM1 output signal is driven Low during fault conditions if the FAULT1 bit in the PWMFAULT register is set.</p>
0	PWM0	R/W	0	<p>MnPWM0 Fault Value</p> <p>Value Description</p> <p>1 The MnPWM0 output signal is driven High during fault conditions if the FAULT0 bit in the PWMFAULT register is set.</p> <p>0 The MnPWM0 output signal is driven Low during fault conditions if the FAULT0 bit in the PWMFAULT register is set.</p>

Register 11: PWM Enable Update (PWMENUPD), offset 0x028

This register specifies when updates to the PWM_nEN bit in the **PWMENABLE** register are performed. The PWM_nEN bit enables the pwmA' or pwmB' output to be passed to the microcontroller's pin. Updates can be immediate or locally or globally synchronized to the next synchronous update.

PWM Enable Update (PWMENUPD)

PWM0 base: 0x4002.8000
 PWM1 base: 0x4002.9000
 Offset 0x028
 Type R/W, reset 0x0000.0000

	31	30	29	28	27	26	25	24	23	22	21	20	19	18	17	16
	reserved															
Type	RO	RO	RO	RO	RO	RO	RO	RO	RO	RO	RO	RO	RO	RO	RO	RO
Reset	0	0	0	0	0	0	0	0	0	0	0	0	0	0	0	0
	15	14	13	12	11	10	9	8	7	6	5	4	3	2	1	0
	ENUPD7		ENUPD6		ENUPD5		ENUPD4		ENUPD3		ENUPD2		ENUPD1		ENUPD0	
Type	R/W	R/W	R/W	R/W	R/W	R/W	R/W	R/W	R/W	R/W	R/W	R/W	R/W	R/W	R/W	R/W
Reset	0	0	0	0	0	0	0	0	0	0	0	0	0	0	0	0

Bit/Field	Name	Type	Reset	Description
31:16	reserved	RO	0x00	Software should not rely on the value of a reserved bit. To provide compatibility with future products, the value of a reserved bit should be preserved across a read-modify-write operation.
15:14	ENUPD7	R/W	0	<p>M_nPWM07 Enable Update Mode</p> <p>Value Description</p> <p>0x0 Immediate Writes to the $PWM7EN$ bit in the PWMENABLE register are used by the PWM generator immediately.</p> <p>0x1 Reserved</p> <p>0x2 Locally Synchronized Writes to the $PWM7EN$ bit in the PWMENABLE register are used by the PWM generator the next time the counter is 0.</p> <p>0x3 Globally Synchronized Writes to the $PWM7EN$ bit in the PWMENABLE register are used by the PWM generator the next time the counter is 0 after a synchronous update has been requested through the PWM Master Control (PWMCTL) register.</p>

Bit/Field	Name	Type	Reset	Description
13:12	ENUPD6	R/W	0	<p>MnPWM6 Enable Update Mode</p> <p>Value Description</p> <p>0x0 Immediate Writes to the <code>PWM6EN</code> bit in the PWMENABLE register are used by the PWM generator immediately.</p> <p>0x1 Reserved</p> <p>0x2 Locally Synchronized Writes to the <code>PWM6EN</code> bit in the PWMENABLE register are used by the PWM generator the next time the counter is 0.</p> <p>0x3 Globally Synchronized Writes to the <code>PWM6EN</code> bit in the PWMENABLE register are used by the PWM generator the next time the counter is 0 after a synchronous update has been requested through the PWM Master Control (PWMCTL) register.</p>
11:10	ENUPD5	R/W	0	<p>MnPWM5 Enable Update Mode</p> <p>Value Description</p> <p>0x0 Immediate Writes to the <code>PWM5EN</code> bit in the PWMENABLE register are used by the PWM generator immediately.</p> <p>0x1 Reserved</p> <p>0x2 Locally Synchronized Writes to the <code>PWM5EN</code> bit in the PWMENABLE register are used by the PWM generator the next time the counter is 0.</p> <p>0x3 Globally Synchronized Writes to the <code>PWM5EN</code> bit in the PWMENABLE register are used by the PWM generator the next time the counter is 0 after a synchronous update has been requested through the PWM Master Control (PWMCTL) register.</p>
9:8	ENUPD4	R/W	0	<p>MnPWM4 Enable Update Mode</p> <p>Value Description</p> <p>0x0 Immediate Writes to the <code>PWM4EN</code> bit in the PWMENABLE register are used by the PWM generator immediately.</p> <p>0x1 Reserved</p> <p>0x2 Locally Synchronized Writes to the <code>PWM4EN</code> bit in the PWMENABLE register are used by the PWM generator the next time the counter is 0.</p> <p>0x3 Globally Synchronized Writes to the <code>PWM4EN</code> bit in the PWMENABLE register are used by the PWM generator the next time the counter is 0 after a synchronous update has been requested through the PWM Master Control (PWMCTL) register.</p>

Bit/Field	Name	Type	Reset	Description
7:6	ENUPD3	R/W	0	<p>MnPWM3 Enable Update Mode</p> <p>Value Description</p> <p>0x0 Immediate Writes to the <code>PWM3EN</code> bit in the PWMENABLE register are used by the PWM generator immediately.</p> <p>0x1 Reserved</p> <p>0x2 Locally Synchronized Writes to the <code>PWM3EN</code> bit in the PWMENABLE register are used by the PWM generator the next time the counter is 0.</p> <p>0x3 Globally Synchronized Writes to the <code>PWM3EN</code> bit in the PWMENABLE register are used by the PWM generator the next time the counter is 0 after a synchronous update has been requested through the PWM Master Control (PWMCTL) register.</p>
5:4	ENUPD2	R/W	0	<p>MnPWM2 Enable Update Mode</p> <p>Value Description</p> <p>0x0 Immediate Writes to the <code>PWM2EN</code> bit in the PWMENABLE register are used by the PWM generator immediately.</p> <p>0x1 Reserved</p> <p>0x2 Locally Synchronized Writes to the <code>PWM2EN</code> bit in the PWMENABLE register are used by the PWM generator the next time the counter is 0.</p> <p>0x3 Globally Synchronized Writes to the <code>PWM2EN</code> bit in the PWMENABLE register are used by the PWM generator the next time the counter is 0 after a synchronous update has been requested through the PWM Master Control (PWMCTL) register.</p>
3:2	ENUPD1	R/W	0	<p>MnPWM1 Enable Update Mode</p> <p>Value Description</p> <p>0x0 Immediate Writes to the <code>PWM1EN</code> bit in the PWMENABLE register are used by the PWM generator immediately.</p> <p>0x1 Reserved</p> <p>0x2 Locally Synchronized Writes to the <code>PWM1EN</code> bit in the PWMENABLE register are used by the PWM generator the next time the counter is 0.</p> <p>0x3 Globally Synchronized Writes to the <code>PWM1EN</code> bit in the PWMENABLE register are used by the PWM generator the next time the counter is 0 after a synchronous update has been requested through the PWM Master Control (PWMCTL) register.</p>

Bit/Field	Name	Type	Reset	Description
1:0	ENUPD0	R/W	0	MnPWM0 Enable Update Mode
				Value Description
				0x0 Immediate Writes to the <code>PWM0EN</code> bit in the <code>PWMENABLE</code> register are used by the PWM generator immediately.
				0x1 Reserved
				0x2 Locally Synchronized Writes to the <code>PWM0EN</code> bit in the <code>PWMENABLE</code> register are used by the PWM generator the next time the counter is 0.
				0x3 Globally Synchronized Writes to the <code>PWM0EN</code> bit in the <code>PWMENABLE</code> register are used by the PWM generator the next time the counter is 0 after a synchronous update has been requested through the PWM Master Control (<code>PWMCTL</code>) register.

Register 12: PWM0 Control (PWM0CTL), offset 0x040

Register 13: PWM1 Control (PWM1CTL), offset 0x080

Register 14: PWM2 Control (PWM2CTL), offset 0x0C0

Register 15: PWM3 Control (PWM3CTL), offset 0x100

These registers configure the PWM signal generation blocks (PWM0CTL controls the PWM generator 0 block, and so on). The Register Update mode, Debug mode, Counting mode, and Block Enable mode are all controlled via these registers. The blocks produce the PWM signals, which can be either two independent PWM signals (from the same counter), or a paired set of PWM signals with dead-band delays added.

The PWM0 block produces the M_n PWM0 and M_n PWM1 outputs, the PWM1 block produces the M_n PWM2 and M_n PWM3 outputs, the PWM2 block produces the M_n PWM4 and M_n PWM5 outputs, and the PWM3 block produces the M_n PWM6 and M_n PWM7 outputs.

PWMn Control (PWMnCTL)

PWM0 base: 0x4002.8000
 PWM1 base: 0x4002.9000
 Offset 0x040
 Type R/W, reset 0x0000.0000

	31	30	29	28	27	26	25	24	23	22	21	20	19	18	17	16
	reserved													LATCH	MINFLTPER	FLTSRC
Type	RO	RO	RO	RO	RO	RO	RO	RO	RO	RO	RO	RO	RO	R/W	R/W	R/W
Reset	0	0	0	0	0	0	0	0	0	0	0	0	0	0	0	0
	15	14	13	12	11	10	9	8	7	6	5	4	3	2	1	0
	DBFALLUPD		DBRISEUPD		DBCTLUPD		GENBUPD		GENAUPD		CMPBUPD	CMPAUPD	LOADUPD	DEBUG	MODE	ENABLE
Type	R/W	R/W	R/W	R/W	R/W	R/W	R/W	R/W	R/W	R/W	R/W	R/W	R/W	R/W	R/W	R/W
Reset	0	0	0	0	0	0	0	0	0	0	0	0	0	0	0	0

Bit/Field	Name	Type	Reset	Description
31:19	reserved	RO	0x000	Software should not rely on the value of a reserved bit. To provide compatibility with future products, the value of a reserved bit should be preserved across a read-modify-write operation.
18	LATCH	R/W	0	Latch Fault Input
				Value Description
			0	Fault Condition Not Latched A fault condition is in effect for as long as the generating source is asserting.
			1	Fault Condition Latched A fault condition is set as the result of the assertion of the faulting source and is held (latched) while the PWMISC INTFAULTn bit is set. Clearing the INTFAULTn bit clears the fault condition.

Bit/Field	Name	Type	Reset	Description
17	MINFLTPER	R/W	0	<p>Minimum Fault Period</p> <p>This bit specifies that the PWM generator enables a one-shot counter to provide a minimum fault condition period.</p> <p>The timer begins counting on the rising edge of the fault condition to extend the condition for a minimum duration of the count value. The timer ignores the state of the fault condition while counting.</p> <p>The minimum fault delay is in effect only when the MINFLTPER bit is set. If a detected fault is in the process of being extended when the MINFLTPER bit is cleared, the fault condition extension is aborted.</p> <p>The delay time is specified by the PWMnMINFLTPER register MFP field value. The effect of this is to pulse stretch the fault condition input.</p> <p>The delay value is defined by the PWM clock period. Because the fault input is not synchronized to the PWM clock, the period of the time is $PWMClock * (MFP \text{ value} + 1)$ or $PWMClock * (MFP \text{ value} + 2)$.</p> <p>The delay function makes sense only if the fault source is unlatched. A latched fault source makes the fault condition appear asserted until cleared by software and negates the utility of the extend feature. It applies to all fault condition sources as specified in the FLTSRC field.</p> <p>Value Description</p> <p>0 The FAULT input deassertion is unaffected.</p> <p>1 The PWMnMINFLTPER one-shot counter is active and extends the period of the fault condition to a minimum period.</p>
16	FLTSRC	R/W	0	<p>Fault Condition Source</p> <p>Value Description</p> <p>0 The Fault condition is determined by the Fault0 input.</p> <p>1 The Fault condition is determined by the configuration of the PWMnFLTSRC0 and PWMnFLTSRC1 registers.</p>
15:14	DBFALLUPD	R/W	0x0	<p>PWMnDBFALL Update Mode</p> <p>Value Description</p> <p>0x0 Immediate</p> <p>The PWMnDBFALL register value is immediately updated on a write.</p> <p>0x1 Reserved</p> <p>0x2 Locally Synchronized</p> <p>Updates to the register are reflected to the generator the next time the counter is 0.</p> <p>0x3 Globally Synchronized</p> <p>Updates to the register are delayed until the next time the counter is 0 after a synchronous update has been requested through the PWMCTL register.</p>

Bit/Field	Name	Type	Reset	Description
13:12	DBRISEUPD	R/W	0x0	<p>PWMnDBRISE Update Mode</p> <p>Value Description</p> <p>0x0 Immediate The PWMnDBRISE register value is immediately updated on a write.</p> <p>0x1 Reserved</p> <p>0x2 Locally Synchronized Updates to the register are reflected to the generator the next time the counter is 0.</p> <p>0x3 Globally Synchronized Updates to the register are delayed until the next time the counter is 0 after a synchronous update has been requested through the PWMCTL register.</p>
11:10	DBCTLUPD	R/W	0x0	<p>PWMnDBCTL Update Mode</p> <p>Value Description</p> <p>0x0 Immediate The PWMnDBCTL register value is immediately updated on a write.</p> <p>0x1 Reserved</p> <p>0x2 Locally Synchronized Updates to the register are reflected to the generator the next time the counter is 0.</p> <p>0x3 Globally Synchronized Updates to the register are delayed until the next time the counter is 0 after a synchronous update has been requested through the PWMCTL register.</p>
9:8	GENBUPD	R/W	0x0	<p>PWMnGENB Update Mode</p> <p>Value Description</p> <p>0x0 Immediate The PWMnGENB register value is immediately updated on a write.</p> <p>0x1 Reserved</p> <p>0x2 Locally Synchronized Updates to the register are reflected to the generator the next time the counter is 0.</p> <p>0x3 Globally Synchronized Updates to the register are delayed until the next time the counter is 0 after a synchronous update has been requested through the PWMCTL register.</p>

Bit/Field	Name	Type	Reset	Description										
7:6	GENAUPD	R/W	0x0	<p>PWMnGENA Update Mode</p> <table border="1"> <thead> <tr> <th>Value</th> <th>Description</th> </tr> </thead> <tbody> <tr> <td>0x0</td> <td>Immediate The PWMnGENA register value is immediately updated on a write.</td> </tr> <tr> <td>0x1</td> <td>Reserved</td> </tr> <tr> <td>0x2</td> <td>Locally Synchronized Updates to the register are reflected to the generator the next time the counter is 0.</td> </tr> <tr> <td>0x3</td> <td>Globally Synchronized Updates to the register are delayed until the next time the counter is 0 after a synchronous update has been requested through the PWMCTL register.</td> </tr> </tbody> </table>	Value	Description	0x0	Immediate The PWMnGENA register value is immediately updated on a write.	0x1	Reserved	0x2	Locally Synchronized Updates to the register are reflected to the generator the next time the counter is 0.	0x3	Globally Synchronized Updates to the register are delayed until the next time the counter is 0 after a synchronous update has been requested through the PWMCTL register.
Value	Description													
0x0	Immediate The PWMnGENA register value is immediately updated on a write.													
0x1	Reserved													
0x2	Locally Synchronized Updates to the register are reflected to the generator the next time the counter is 0.													
0x3	Globally Synchronized Updates to the register are delayed until the next time the counter is 0 after a synchronous update has been requested through the PWMCTL register.													
5	CMPBUPD	R/W	0	<p>Comparator B Update Mode</p> <table border="1"> <thead> <tr> <th>Value</th> <th>Description</th> </tr> </thead> <tbody> <tr> <td>0</td> <td>Locally Synchronized Updates to the PWMnCMPB register are reflected to the generator the next time the counter is 0.</td> </tr> <tr> <td>1</td> <td>Globally Synchronized Updates to the register are delayed until the next time the counter is 0 after a synchronous update has been requested through the PWMCTL register.</td> </tr> </tbody> </table>	Value	Description	0	Locally Synchronized Updates to the PWMnCMPB register are reflected to the generator the next time the counter is 0.	1	Globally Synchronized Updates to the register are delayed until the next time the counter is 0 after a synchronous update has been requested through the PWMCTL register.				
Value	Description													
0	Locally Synchronized Updates to the PWMnCMPB register are reflected to the generator the next time the counter is 0.													
1	Globally Synchronized Updates to the register are delayed until the next time the counter is 0 after a synchronous update has been requested through the PWMCTL register.													
4	CMPAUPD	R/W	0	<p>Comparator A Update Mode</p> <table border="1"> <thead> <tr> <th>Value</th> <th>Description</th> </tr> </thead> <tbody> <tr> <td>0</td> <td>Locally Synchronized Updates to the PWMnCMPA register are reflected to the generator the next time the counter is 0.</td> </tr> <tr> <td>1</td> <td>Globally Synchronized Updates to the register are delayed until the next time the counter is 0 after a synchronous update has been requested through the PWMCTL register.</td> </tr> </tbody> </table>	Value	Description	0	Locally Synchronized Updates to the PWMnCMPA register are reflected to the generator the next time the counter is 0.	1	Globally Synchronized Updates to the register are delayed until the next time the counter is 0 after a synchronous update has been requested through the PWMCTL register.				
Value	Description													
0	Locally Synchronized Updates to the PWMnCMPA register are reflected to the generator the next time the counter is 0.													
1	Globally Synchronized Updates to the register are delayed until the next time the counter is 0 after a synchronous update has been requested through the PWMCTL register.													
3	LOADUPD	R/W	0	<p>Load Register Update Mode</p> <table border="1"> <thead> <tr> <th>Value</th> <th>Description</th> </tr> </thead> <tbody> <tr> <td>0</td> <td>Locally Synchronized Updates to the PWMnLOAD register are reflected to the generator the next time the counter is 0.</td> </tr> <tr> <td>1</td> <td>Globally Synchronized Updates to the register are delayed until the next time the counter is 0 after a synchronous update has been requested through the PWMCTL register.</td> </tr> </tbody> </table>	Value	Description	0	Locally Synchronized Updates to the PWMnLOAD register are reflected to the generator the next time the counter is 0.	1	Globally Synchronized Updates to the register are delayed until the next time the counter is 0 after a synchronous update has been requested through the PWMCTL register.				
Value	Description													
0	Locally Synchronized Updates to the PWMnLOAD register are reflected to the generator the next time the counter is 0.													
1	Globally Synchronized Updates to the register are delayed until the next time the counter is 0 after a synchronous update has been requested through the PWMCTL register.													

Bit/Field	Name	Type	Reset	Description
2	DEBUG	R/W	0	Debug Mode Value Description 0 The counter stops running when it next reaches 0 and continues running again when no longer in Debug mode. 1 The counter always runs when in Debug mode.
1	MODE	R/W	0	Counter Mode Value Description 0 The counter counts down from the load value to 0 and then wraps back to the load value (Count-Down mode). 1 The counter counts up from 0 to the load value, back down to 0, and then repeats (Count-Up/Down mode).
0	ENABLE	R/W	0	PWM Block Enable Value Description 0 The entire PWM generation block is disabled and not clocked. 1 The PWM generation block is enabled and produces PWM signals.

Register 16: PWM0 Interrupt and Trigger Enable (PWM0INTEN), offset 0x044

Register 17: PWM1 Interrupt and Trigger Enable (PWM1INTEN), offset 0x084

Register 18: PWM2 Interrupt and Trigger Enable (PWM2INTEN), offset 0x0C4

Register 19: PWM3 Interrupt and Trigger Enable (PWM3INTEN), offset 0x104

These registers control the interrupt and ADC trigger generation capabilities of the PWM generators (**PWM0INTEN** controls the PWM generator 0 block, and so on). The events that can cause an interrupt, or an ADC trigger are:

- The counter being equal to the load register
- The counter being equal to zero
- The counter being equal to the **PWMnCMPA** register while counting up
- The counter being equal to the **PWMnCMPA** register while counting down
- The counter being equal to the **PWMnCMPB** register while counting up
- The counter being equal to the **PWMnCMPB** register while counting down

Any combination of these events can generate either an interrupt or an ADC trigger, though no determination can be made as to the actual event that caused an ADC trigger if more than one is specified. The **PWMnRIS** register provides information about which events have caused raw interrupts.

PWMn Interrupt and Trigger Enable (PWMnINTEN)

PWM0 base: 0x4002.8000
 PWM1 base: 0x4002.9000
 Offset 0x044
 Type R/W, reset 0x0000.0000

	31	30	29	28	27	26	25	24	23	22	21	20	19	18	17	16
	reserved															
Type	RO	RO	RO	RO	RO	RO	RO	RO	RO	RO	RO	RO	RO	RO	RO	RO
Reset	0	0	0	0	0	0	0	0	0	0	0	0	0	0	0	0
	15	14	13	12	11	10	9	8	7	6	5	4	3	2	1	0
	reserved		TRCMPBD	TRCMPBU	TRCMPAD	TRCMPAU	TRCNTLOAD	TRCNTZERO	reserved		INTCMPBD	INTCMPBU	INTCMPAD	INTCMPAU	INTCNTLOAD	INTCNTZERO
Type	RO	RO	R/W	R/W	R/W	R/W	R/W	R/W	RO	RO	R/W	R/W	R/W	R/W	R/W	R/W
Reset	0	0	0	0	0	0	0	0	0	0	0	0	0	0	0	0

Bit/Field	Name	Type	Reset	Description
31:14	reserved	RO	0	Software should not rely on the value of a reserved bit. To provide compatibility with future products, the value of a reserved bit should be preserved across a read-modify-write operation.
13	TRCMPBD	R/W	0	Trigger for Counter= PWMnCMPB Down
				Value Description
				1 An ADC trigger pulse is output when the counter matches the value in the PWMnCMPB register value while counting down.
				0 No ADC trigger is output.

Bit/Field	Name	Type	Reset	Description
12	TRCMPBU	R/W	0	<p>Trigger for Counter=PWMnCMPB Up</p> <p>Value Description</p> <p>1 An ADC trigger pulse is output when the counter matches the value in the PWMnCMPB register value while counting up.</p> <p>0 No ADC trigger is output.</p>
11	TRCMPAD	R/W	0	<p>Trigger for Counter=PWMnCMPA Down</p> <p>Value Description</p> <p>1 An ADC trigger pulse is output when the counter matches the value in the PWMnCMPA register value while counting down.</p> <p>0 No ADC trigger is output.</p>
10	TRCMPAU	R/W	0	<p>Trigger for Counter=PWMnCMPA Up</p> <p>Value Description</p> <p>1 An ADC trigger pulse is output when the counter matches the value in the PWMnCMPA register value while counting up.</p> <p>0 No ADC trigger is output.</p>
9	TRCNTLOAD	R/W	0	<p>Trigger for Counter=PWMnLOAD</p> <p>Value Description</p> <p>1 An ADC trigger pulse is output when the counter matches the PWMnLOAD register.</p> <p>0 No ADC trigger is output.</p>
8	TRCNTZERO	R/W	0	<p>Trigger for Counter=0</p> <p>Value Description</p> <p>1 An ADC trigger pulse is output when the counter is 0.</p> <p>0 No ADC trigger is output.</p>
7:6	reserved	RO	0x0	Software should not rely on the value of a reserved bit. To provide compatibility with future products, the value of a reserved bit should be preserved across a read-modify-write operation.
5	INTCMPBD	R/W	0	<p>Interrupt for Counter=PWMnCMPB Down</p> <p>Value Description</p> <p>1 A raw interrupt occurs when the counter matches the value in the PWMnCMPB register value while counting down.</p> <p>0 No interrupt.</p>

Bit/Field	Name	Type	Reset	Description
4	INTCMPBU	R/W	0	Interrupt for Counter= PWMnCMPB Up Value Description 1 A raw interrupt occurs when the counter matches the value in the PWMnCMPB register value while counting up. 0 No interrupt.
3	INTCMPAD	R/W	0	Interrupt for Counter= PWMnCMPA Down Value Description 1 A raw interrupt occurs when the counter matches the value in the PWMnCMPA register value while counting down. 0 No interrupt.
2	INTCMPAU	R/W	0	Interrupt for Counter= PWMnCMPA Up Value Description 1 A raw interrupt occurs when the counter matches the value in the PWMnCMPA register value while counting up. 0 No interrupt.
1	INTCNTLOAD	R/W	0	Interrupt for Counter= PWMnLOAD Value Description 1 A raw interrupt occurs when the counter matches the value in the PWMnLOAD register value. 0 No interrupt.
0	INTCNTZERO	R/W	0	Interrupt for Counter=0 Value Description 1 A raw interrupt occurs when the counter is zero. 0 No interrupt.

Register 20: PWM0 Raw Interrupt Status (PWM0RIS), offset 0x048

Register 21: PWM1 Raw Interrupt Status (PWM1RIS), offset 0x088

Register 22: PWM2 Raw Interrupt Status (PWM2RIS), offset 0x0C8

Register 23: PWM3 Raw Interrupt Status (PWM3RIS), offset 0x108

These registers provide the current set of interrupt sources that are asserted, regardless of whether they cause an interrupt to be asserted to the controller (**PWM0RIS** controls the PWM generator 0 block, and so on). If a bit is set, the event has occurred; if a bit is clear, the event has not occurred. Bits in this register are cleared by writing a 1 to the corresponding bit in the **PWMnISC** register.

PWMn Raw Interrupt Status (PWMnRIS)

PWM0 base: 0x4002.8000
 PWM1 base: 0x4002.9000
 Offset 0x048
 Type RO, reset 0x0000.0000

	31	30	29	28	27	26	25	24	23	22	21	20	19	18	17	16	
	reserved																
Type	RO	RO	RO	RO	RO	RO	RO	RO	RO	RO	RO	RO	RO	RO	RO	RO	
Reset	0	0	0	0	0	0	0	0	0	0	0	0	0	0	0	0	
	15	14	13	12	11	10	9	8	7	6	5	4	3	2	1	0	
	reserved											INTCMPBD	INTCMPBU	INTCMPAD	INTCMPAU	INTCNTLOAD	INTCNTZERO
Type	RO	RO	RO	RO	RO	RO	RO	RO	RO	RO	RO	RO	RO	RO	RO	RO	
Reset	0	0	0	0	0	0	0	0	0	0	0	0	0	0	0	0	

Bit/Field	Name	Type	Reset	Description
31:6	reserved	RO	0	Software should not rely on the value of a reserved bit. To provide compatibility with future products, the value of a reserved bit should be preserved across a read-modify-write operation.
5	INTCMPBD	RO	0	Comparator B Down Interrupt Status Value Description 1 The counter has matched the value in the PWMnCMPB register while counting down. 0 An interrupt has not occurred. This bit is cleared by writing a 1 to the INTCMPBD bit in the PWMnISC register.
4	INTCMPBU	RO	0	Comparator B Up Interrupt Status Value Description 1 The counter has matched the value in the PWMnCMPB register while counting up. 0 An interrupt has not occurred. This bit is cleared by writing a 1 to the INTCMPBU bit in the PWMnISC register.

Bit/Field	Name	Type	Reset	Description
3	INTCMPAD	RO	0	<p>Comparator A Down Interrupt Status</p> <p>Value Description</p> <p>1 The counter has matched the value in the PWMnCMPA register while counting down.</p> <p>0 An interrupt has not occurred.</p> <p>This bit is cleared by writing a 1 to the INTCMPAD bit in the PWMnISC register.</p>
2	INTCMPAU	RO	0	<p>Comparator A Up Interrupt Status</p> <p>Value Description</p> <p>1 The counter has matched the value in the PWMnCMPA register while counting up.</p> <p>0 An interrupt has not occurred.</p> <p>This bit is cleared by writing a 1 to the INTCMPAU bit in the PWMnISC register.</p>
1	INTCNTLOAD	RO	0	<p>Counter=Load Interrupt Status</p> <p>Value Description</p> <p>1 The counter has matched the value in the PWMnLOAD register.</p> <p>0 An interrupt has not occurred.</p> <p>This bit is cleared by writing a 1 to the INTCNTLOAD bit in the PWMnISC register.</p>
0	INTCNTZERO	RO	0	<p>Counter=0 Interrupt Status</p> <p>Value Description</p> <p>1 The counter has matched zero.</p> <p>0 An interrupt has not occurred.</p> <p>This bit is cleared by writing a 1 to the INTCNTZERO bit in the PWMnISC register.</p>

Register 24: PWM0 Interrupt Status and Clear (PWM0ISC), offset 0x04C

Register 25: PWM1 Interrupt Status and Clear (PWM1ISC), offset 0x08C

Register 26: PWM2 Interrupt Status and Clear (PWM2ISC), offset 0x0CC

Register 27: PWM3 Interrupt Status and Clear (PWM3ISC), offset 0x10C

These registers provide the current set of interrupt sources that are asserted to the interrupt controller (**PWM0ISC** controls the PWM generator 0 block, and so on). A bit is set if the event has occurred and is enabled in the **PWMnINTEN** register; if a bit is clear, the event has not occurred or is not enabled. These are R/W1C registers; writing a 1 to a bit position clears the corresponding interrupt reason.

PWMn Interrupt Status and Clear (PWMnISC)

PWM0 base: 0x4002.8000
 PWM1 base: 0x4002.9000
 Offset 0x04C
 Type R/W1C, reset 0x0000.0000

	31	30	29	28	27	26	25	24	23	22	21	20	19	18	17	16	
	reserved																
Type	RO	RO	RO	RO	RO	RO	RO	RO	RO	RO	RO	RO	RO	RO	RO	RO	
Reset	0	0	0	0	0	0	0	0	0	0	0	0	0	0	0	0	
	15	14	13	12	11	10	9	8	7	6	5	4	3	2	1	0	
	reserved											INTCMPBD	INTCMPBU	INTCMPAD	INTCMPAU	INTCNTLOAD	INTCNTZERO
Type	RO	RO	RO	RO	RO	RO	RO	RO	RO	RO	R/W1C	R/W1C	R/W1C	R/W1C	R/W1C	R/W1C	
Reset	0	0	0	0	0	0	0	0	0	0	0	0	0	0	0	0	

Bit/Field	Name	Type	Reset	Description
31:6	reserved	RO	0	Software should not rely on the value of a reserved bit. To provide compatibility with future products, the value of a reserved bit should be preserved across a read-modify-write operation.
5	INTCMPBD	R/W1C	0	<p>Comparator B Down Interrupt</p> <p>Value Description</p> <p>1 The INTCMPBD bits in the PWMnRIS and PWMnINTEN registers are set, providing an interrupt to the interrupt controller.</p> <p>0 No interrupt has occurred or the interrupt is masked.</p> <p>This bit is cleared by writing a 1. Clearing this bit also clears the INTCMPBD bit in the PWMnRIS register.</p>
4	INTCMPBU	R/W1C	0	<p>Comparator B Up Interrupt</p> <p>Value Description</p> <p>1 The INTCMPBU bits in the PWMnRIS and PWMnINTEN registers are set, providing an interrupt to the interrupt controller.</p> <p>0 No interrupt has occurred or the interrupt is masked.</p> <p>This bit is cleared by writing a 1. Clearing this bit also clears the INTCMPBU bit in the PWMnRIS register.</p>

Bit/Field	Name	Type	Reset	Description
3	INTCMPAD	R/W1C	0	<p>Comparator A Down Interrupt</p> <p>Value Description</p> <p>1 The INTCMPAD bits in the PWMnRIS and PWMnINTEN registers are set, providing an interrupt to the interrupt controller.</p> <p>0 No interrupt has occurred or the interrupt is masked.</p> <p>This bit is cleared by writing a 1. Clearing this bit also clears the INTCMPAD bit in the PWMnRIS register.</p>
2	INTCMPAU	R/W1C	0	<p>Comparator A Up Interrupt</p> <p>Value Description</p> <p>1 The INTCMPAU bits in the PWMnRIS and PWMnINTEN registers are set, providing an interrupt to the interrupt controller.</p> <p>0 No interrupt has occurred or the interrupt is masked.</p> <p>This bit is cleared by writing a 1. Clearing this bit also clears the INTCMPAU bit in the PWMnRIS register.</p>
1	INTCNTLOAD	R/W1C	0	<p>Counter=Load Interrupt</p> <p>Value Description</p> <p>1 The INTCNTLOAD bits in the PWMnRIS and PWMnINTEN registers are set, providing an interrupt to the interrupt controller.</p> <p>0 No interrupt has occurred or the interrupt is masked.</p> <p>This bit is cleared by writing a 1. Clearing this bit also clears the INTCNTLOAD bit in the PWMnRIS register.</p>
0	INTCNTZERO	R/W1C	0	<p>Counter=0 Interrupt</p> <p>Value Description</p> <p>1 The INTCNTZERO bits in the PWMnRIS and PWMnINTEN registers are set, providing an interrupt to the interrupt controller.</p> <p>0 No interrupt has occurred or the interrupt is masked.</p> <p>This bit is cleared by writing a 1. Clearing this bit also clears the INTCNTZERO bit in the PWMnRIS register.</p>

Register 28: PWM0 Load (PWM0LOAD), offset 0x050

Register 29: PWM1 Load (PWM1LOAD), offset 0x090

Register 30: PWM2 Load (PWM2LOAD), offset 0x0D0

Register 31: PWM3 Load (PWM3LOAD), offset 0x110

These registers contain the load value for the PWM counter (**PWM0LOAD** controls the PWM generator 0 block, and so on). Based on the counter mode configured by the **MODE** bit in the **PWMnCTL** register, this value is either loaded into the counter after it reaches zero or is the limit of up-counting after which the counter decrements back to zero. When this value matches the counter, a pulse is output which can be configured to drive the generation of the pwmA and/or pwmB signal (via the **PWMnGENA/PWMnGENB** register) or drive an interruptor ADC trigger (via the **PWMnINTEN** register).

If the Load Value Update mode is locally synchronized (based on the **LOADUPD** field encoding in the **PWMnCTL** register), the 16-bit **LOAD** value is used the next time the counter reaches zero. If the update mode is globally synchronized, it is used the next time the counter reaches zero after a synchronous update has been requested through the **PWM Master Control (PWMCTL)** register (see page 1203). If this register is re-written before the actual update occurs, the previous value is never used and is lost.

PWMn Load (PWMnLOAD)

PWM0 base: 0x4002.8000
 PWM1 base: 0x4002.9000
 Offset 0x050
 Type R/W, reset 0x0000.0000

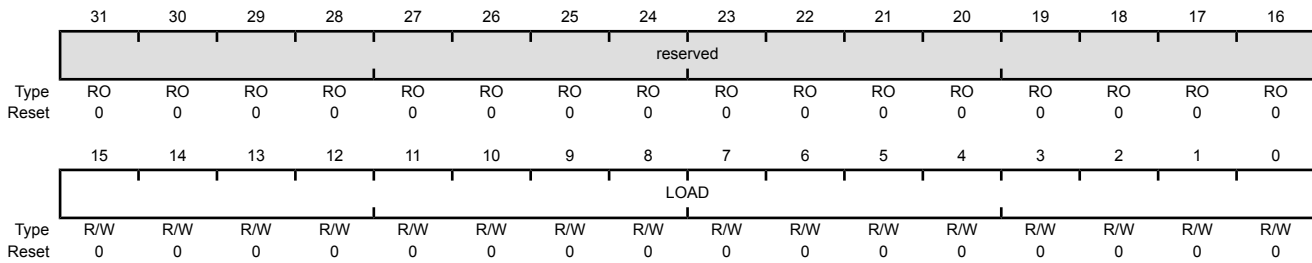

Bit/Field	Name	Type	Reset	Description
31:16	reserved	RO	0x0000	Software should not rely on the value of a reserved bit. To provide compatibility with future products, the value of a reserved bit should be preserved across a read-modify-write operation.
15:0	LOAD	R/W	0x0000	Counter Load Value The counter load value.

Register 32: PWM0 Counter (PWM0COUNT), offset 0x054**Register 33: PWM1 Counter (PWM1COUNT), offset 0x094****Register 34: PWM2 Counter (PWM2COUNT), offset 0x0D4****Register 35: PWM3 Counter (PWM3COUNT), offset 0x114**

These registers contain the current value of the PWM counter (**PWM0COUNT** is the value of the PWM generator 0 block, and so on). When this value matches zero or the value in the **PWMnLOAD**, **PWMnCMPA**, or **PWMnCMPB** registers, a pulse is output which can be configured to drive the generation of a PWM signal or drive an interrupt or ADC trigger.

PWMn Counter (PWMnCOUNT)

PWM0 base: 0x4002.8000

PWM1 base: 0x4002.9000

Offset 0x054

Type RO, reset 0x0000.0000

	31	30	29	28	27	26	25	24	23	22	21	20	19	18	17	16
	reserved															
Type	RO	RO	RO	RO	RO	RO	RO	RO	RO	RO	RO	RO	RO	RO	RO	RO
Reset	0	0	0	0	0	0	0	0	0	0	0	0	0	0	0	0
	15	14	13	12	11	10	9	8	7	6	5	4	3	2	1	0
	COUNT															
Type	RO	RO	RO	RO	RO	RO	RO	RO	RO	RO	RO	RO	RO	RO	RO	RO
Reset	0	0	0	0	0	0	0	0	0	0	0	0	0	0	0	0

Bit/Field	Name	Type	Reset	Description
31:16	reserved	RO	0x0000	Software should not rely on the value of a reserved bit. To provide compatibility with future products, the value of a reserved bit should be preserved across a read-modify-write operation.
15:0	COUNT	RO	0x0000	Counter Value The current value of the counter.

Register 36: PWM0 Compare A (PWM0CMPA), offset 0x058

Register 37: PWM1 Compare A (PWM1CMPA), offset 0x098

Register 38: PWM2 Compare A (PWM2CMPA), offset 0x0D8

Register 39: PWM3 Compare A (PWM3CMPA), offset 0x118

These registers contain a value to be compared against the counter (**PWM0CMPA** controls the PWM generator 0 block, and so on). When this value matches the counter, a pulse is output which can be configured to drive the generation of the pwmA and pwmB signals (via the **PWMnGENA** and **PWMnGENB** registers) or drive an interrupt or ADC trigger (via the **PWMnINTEN** register). If the value of this register is greater than the **PWMnLOAD** register (see page 1240), then no pulse is ever output.

If the comparator A update mode is locally synchronized (based on the **COMPAUPD** bit in the **PWMnCTL** register), the 16-bit **COMPA** value is used the next time the counter reaches zero. If the update mode is globally synchronized, it is used the next time the counter reaches zero after a synchronous update has been requested through the **PWM Master Control (PWMCTL)** register (see page 1203). If this register is rewritten before the actual update occurs, the previous value is never used and is lost.

PWMn Compare A (PWMnCMPA)

PWM0 base: 0x4002.8000
 PWM1 base: 0x4002.9000
 Offset 0x058
 Type R/W, reset 0x0000.0000

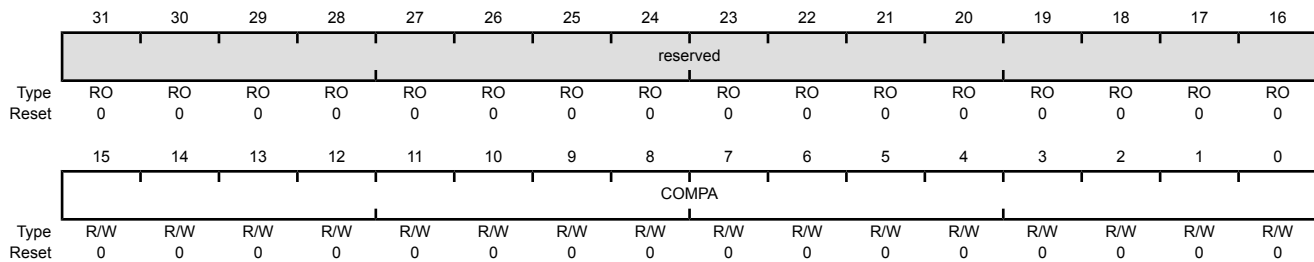

Bit/Field	Name	Type	Reset	Description
31:16	reserved	RO	0x00	Software should not rely on the value of a reserved bit. To provide compatibility with future products, the value of a reserved bit should be preserved across a read-modify-write operation.
15:0	COMPA	R/W	0x00	Comparator A Value The value to be compared against the counter.

Register 40: PWM0 Compare B (PWM0CMPB), offset 0x05C**Register 41: PWM1 Compare B (PWM1CMPB), offset 0x09C****Register 42: PWM2 Compare B (PWM2CMPB), offset 0x0DC****Register 43: PWM3 Compare B (PWM3CMPB), offset 0x11C**

These registers contain a value to be compared against the counter (**PWM0CMPB** controls the PWM generator 0 block, and so on). When this value matches the counter, a pulse is output which can be configured to drive the generation of the pwmA and pwmB signals (via the **PWMnGENA** and **PWMnGENB** registers) or drive an interrupt or ADC trigger (via the **PWMnINTEN** register). If the value of this register is greater than the **PWMnLOAD** register, no pulse is ever output.

If the comparator B update mode is locally synchronized (based on the **COMPBUPD** bit in the **PWMnCTL** register), the 16-bit **COMPB** value is used the next time the counter reaches zero. If the update mode is globally synchronized, it is used the next time the counter reaches zero after a synchronous update has been requested through the **PWM Master Control (PWMCTL)** register (see page 1203). If this register is rewritten before the actual update occurs, the previous value is never used and is lost.

PWMn Compare B (PWMnCMPB)

PWM0 base: 0x4002.8000
 PWM1 base: 0x4002.9000
 Offset 0x05C
 Type R/W, reset 0x0000.0000

	31	30	29	28	27	26	25	24	23	22	21	20	19	18	17	16
	reserved															
Type	RO	RO	RO	RO	RO	RO	RO	RO	RO	RO	RO	RO	RO	RO	RO	RO
Reset	0	0	0	0	0	0	0	0	0	0	0	0	0	0	0	0
	15	14	13	12	11	10	9	8	7	6	5	4	3	2	1	0
	COMPB															
Type	R/W	R/W	R/W	R/W	R/W	R/W	R/W	R/W	R/W	R/W	R/W	R/W	R/W	R/W	R/W	R/W
Reset	0	0	0	0	0	0	0	0	0	0	0	0	0	0	0	0

Bit/Field	Name	Type	Reset	Description
31:16	reserved	RO	0x0000	Software should not rely on the value of a reserved bit. To provide compatibility with future products, the value of a reserved bit should be preserved across a read-modify-write operation.
15:0	COMPB	R/W	0x0000	Comparator B Value The value to be compared against the counter.

Register 44: PWM0 Generator A Control (PWM0GENA), offset 0x060

Register 45: PWM1 Generator A Control (PWM1GENA), offset 0x0A0

Register 46: PWM2 Generator A Control (PWM2GENA), offset 0x0E0

Register 47: PWM3 Generator A Control (PWM3GENA), offset 0x120

These registers control the generation of the pwmA signal based on the load and zero output pulses from the counter, as well as the compare A and compare B pulses from the comparators (**PWM0GENA** controls the PWM generator 0 block, and so on). When the counter is running in Count-Down mode, only four of these events occur; when running in Count-Up/Down mode, all six occur. These events provide great flexibility in the positioning and duty cycle of the resulting PWM signal.

The **PWM0GENA** register controls generation of the pwm0A signal; **PWM1GENA**, the pwm1A signal; **PWM2GENA**, the pwm2A signal; and **PWM3GENA**, the pwm3A signal.

If a zero or load event coincides with a compare A or compare B event, the zero or load action is taken and the compare A or compare B action is ignored. If a compare A event coincides with a compare B event, the compare A action is taken and the compare B action is ignored.

If the Generator A update mode is immediate (based on the **GENAUPD** field encoding in the **PWMnCTL** register), the **ACTCMPBD**, **ACTCMPBU**, **ACTCMPAD**, **ACTCMPAU**, **ACTLOAD**, and **ACTZERO** values are used immediately. If the update mode is locally synchronized, these values are used the next time the counter reaches zero. If the update mode is globally synchronized, these values are used the next time the counter reaches zero after a synchronous update has been requested through the **PWM Master Control (PWMCTL)** register (see page 1203). If this register is rewritten before the actual update occurs, the previous value is never used and is lost.

PWMn Generator A Control (PWMnGENA)

PWM0 base: 0x4002.8000
 PWM1 base: 0x4002.9000
 Offset 0x060
 Type R/W, reset 0x0000.0000

	31	30	29	28	27	26	25	24	23	22	21	20	19	18	17	16
	reserved															
Type	RO	RO	RO	RO	RO	RO	RO	RO	RO	RO	RO	RO	RO	RO	RO	RO
Reset	0	0	0	0	0	0	0	0	0	0	0	0	0	0	0	0
	15	14	13	12	11	10	9	8	7	6	5	4	3	2	1	0
	reserved				ACTCMPBD		ACTCMPBU		ACTCMPAD		ACTCMPAU		ACTLOAD		ACTZERO	
Type	RO	RO	RO	RO	R/W	R/W	R/W	R/W	R/W	R/W	R/W	R/W	R/W	R/W	R/W	R/W
Reset	0	0	0	0	0	0	0	0	0	0	0	0	0	0	0	0

Bit/Field	Name	Type	Reset	Description
31:12	reserved	RO	0x0000.0	Software should not rely on the value of a reserved bit. To provide compatibility with future products, the value of a reserved bit should be preserved across a read-modify-write operation.

Bit/Field	Name	Type	Reset	Description
11:10	ACTCMPBD	R/W	0x0	<p>Action for Comparator B Down</p> <p>This field specifies the action to be taken when the counter matches comparator B while counting down.</p> <p>Value Description</p> <p>0x0 Do nothing.</p> <p>0x1 Invert pwmA.</p> <p>0x2 Drive pwmA Low.</p> <p>0x3 Drive pwmA High.</p>
9:8	ACTCMPBU	R/W	0x0	<p>Action for Comparator B Up</p> <p>This field specifies the action to be taken when the counter matches comparator B while counting up. This action can only occur when the MODE bit in the PWMnCTL register is set.</p> <p>Value Description</p> <p>0x0 Do nothing.</p> <p>0x1 Invert pwmA.</p> <p>0x2 Drive pwmA Low.</p> <p>0x3 Drive pwmA High.</p>
7:6	ACTCMPAD	R/W	0x0	<p>Action for Comparator A Down</p> <p>This field specifies the action to be taken when the counter matches comparator A while counting down.</p> <p>Value Description</p> <p>0x0 Do nothing.</p> <p>0x1 Invert pwmA.</p> <p>0x2 Drive pwmA Low.</p> <p>0x3 Drive pwmA High.</p>
5:4	ACTCMPAU	R/W	0x0	<p>Action for Comparator A Up</p> <p>This field specifies the action to be taken when the counter matches comparator A while counting up. This action can only occur when the MODE bit in the PWMnCTL register is set.</p> <p>Value Description</p> <p>0x0 Do nothing.</p> <p>0x1 Invert pwmA.</p> <p>0x2 Drive pwmA Low.</p> <p>0x3 Drive pwmA High.</p>

Bit/Field	Name	Type	Reset	Description
3:2	ACTLOAD	R/W	0x0	Action for Counter=LOAD This field specifies the action to be taken when the counter matches the value in the PWMnLOAD register. Value Description 0x0 Do nothing. 0x1 Invert pwmA. 0x2 Drive pwmA Low. 0x3 Drive pwmA High.
1:0	ACTZERO	R/W	0x0	Action for Counter=0 This field specifies the action to be taken when the counter is zero. Value Description 0x0 Do nothing. 0x1 Invert pwmA. 0x2 Drive pwmA Low. 0x3 Drive pwmA High.

Register 48: PWM0 Generator B Control (PWM0GENB), offset 0x064**Register 49: PWM1 Generator B Control (PWM1GENB), offset 0x0A4****Register 50: PWM2 Generator B Control (PWM2GENB), offset 0x0E4****Register 51: PWM3 Generator B Control (PWM3GENB), offset 0x124**

These registers control the generation of the pwmB signal based on the load and zero output pulses from the counter, as well as the compare A and compare B pulses from the comparators (**PWM0GENB** controls the PWM generator 0 block, and so on). When the counter is running in Count-Down mode, only four of these events occur; when running in Count-Up/Down mode, all six occur. These events provide great flexibility in the positioning and duty cycle of the resulting PWM signal.

The **PWM0GENB** register controls generation of the pwm0B signal; **PWM1GENB**, the pwm1B signal; **PWM2GENB**, the pwm2B signal; and **PWM3GENB**, the pwm3B signal.

If a zero or load event coincides with a compare A or compare B event, the zero or load action is taken and the compare A or compare B action is ignored. If a compare A event coincides with a compare B event, the compare B action is taken and the compare A action is ignored.

If the Generator B update mode is immediate (based on the GENBUPD field encoding in the **PWMnCTL** register), the ACTCMPBD, ACTCMPBU, ACTCMPAD, ACTCMPAU, ACTLOAD, and ACTZERO values are used immediately. If the update mode is locally synchronized, these values are used the next time the counter reaches zero. If the update mode is globally synchronized, these values are used the next time the counter reaches zero after a synchronous update has been requested through the **PWM Master Control (PWMCTL)** register (see page 1203). If this register is rewritten before the actual update occurs, the previous value is never used and is lost.

PWMn Generator B Control (PWMnGENB), offset 0x064

PWM0 base: 0x4002.8000
 PWM1 base: 0x4002.9000
 Offset 0x064
 Type R/W, reset 0x0000.0000

	31	30	29	28	27	26	25	24	23	22	21	20	19	18	17	16
	reserved															
Type	RO	RO	RO	RO	RO	RO	RO	RO	RO	RO	RO	RO	RO	RO	RO	RO
Reset	0	0	0	0	0	0	0	0	0	0	0	0	0	0	0	0
	15	14	13	12	11	10	9	8	7	6	5	4	3	2	1	0
	reserved				ACTCMPBD	ACTCMPBU	ACTCMPAD	ACTCMPAU	ACTLOAD	ACTZERO						
Type	RO	RO	RO	RO	R/W	R/W	R/W	R/W	R/W	R/W	R/W	R/W	R/W	R/W	R/W	R/W
Reset	0	0	0	0	0	0	0	0	0	0	0	0	0	0	0	0

Bit/Field	Name	Type	Reset	Description
31:12	reserved	RO	0x0000.0	Software should not rely on the value of a reserved bit. To provide compatibility with future products, the value of a reserved bit should be preserved across a read-modify-write operation.

Bit/Field	Name	Type	Reset	Description
11:10	ACTCMPBD	R/W	0x0	<p>Action for Comparator B Down</p> <p>This field specifies the action to be taken when the counter matches comparator B while counting down.</p> <p>Value Description</p> <p>0x0 Do nothing.</p> <p>0x1 Invert pwmB.</p> <p>0x2 Drive pwmB Low.</p> <p>0x3 Drive pwmB High.</p>
9:8	ACTCMPBU	R/W	0x0	<p>Action for Comparator B Up</p> <p>This field specifies the action to be taken when the counter matches comparator B while counting up. This action can only occur when the MODE bit in the PWMnCTL register is set.</p> <p>Value Description</p> <p>0x0 Do nothing.</p> <p>0x1 Invert pwmB.</p> <p>0x2 Drive pwmB Low.</p> <p>0x3 Drive pwmB High.</p>
7:6	ACTCMPAD	R/W	0x0	<p>Action for Comparator A Down</p> <p>This field specifies the action to be taken when the counter matches comparator A while counting down.</p> <p>Value Description</p> <p>0x0 Do nothing.</p> <p>0x1 Invert pwmB.</p> <p>0x2 Drive pwmB Low.</p> <p>0x3 Drive pwmB High.</p>
5:4	ACTCMPAU	R/W	0x0	<p>Action for Comparator A Up</p> <p>This field specifies the action to be taken when the counter matches comparator A while counting up. This action can only occur when the MODE bit in the PWMnCTL register is set.</p> <p>Value Description</p> <p>0x0 Do nothing.</p> <p>0x1 Invert pwmB.</p> <p>0x2 Drive pwmB Low.</p> <p>0x3 Drive pwmB High.</p>

Bit/Field	Name	Type	Reset	Description
3:2	ACTLOAD	R/W	0x0	Action for Counter=LOAD This field specifies the action to be taken when the counter matches the load value. Value Description 0x0 Do nothing. 0x1 Invert pwmB. 0x2 Drive pwmB Low. 0x3 Drive pwmB High.
1:0	ACTZERO	R/W	0x0	Action for Counter=0 This field specifies the action to be taken when the counter is 0. Value Description 0x0 Do nothing. 0x1 Invert pwmB. 0x2 Drive pwmB Low. 0x3 Drive pwmB High.

Register 52: PWM0 Dead-Band Control (PWM0DBCTL), offset 0x068

Register 53: PWM1 Dead-Band Control (PWM1DBCTL), offset 0x0A8

Register 54: PWM2 Dead-Band Control (PWM2DBCTL), offset 0x0E8

Register 55: PWM3 Dead-Band Control (PWM3DBCTL), offset 0x128

The **PWMnDBCTL** register controls the dead-band generator, which produces the M_nP_{WMn} signals based on the *pwmA* and *pwmB* signals. When disabled, the *pwmA* signal passes through to the *pwmA'* signal and the *pwmB* signal passes through to the *pwmB'* signal. When dead-band control is enabled, the *pwmB* signal is ignored, the *pwmA'* signal is generated by delaying the rising edge(s) of the *pwmA* signal by the value in the **PWMnDBRISE** register (see page 1251), and the *pwmB'* signal is generated by inverting the *pwmA* signal and delaying the falling edge(s) of the *pwmA* signal by the value in the **PWMnDBFALL** register (see page 1252). The Output Control block outputs the *pwm0A'* signal on the M_nP_{WM0} signal and the *pwm0B'* signal on the M_nP_{WM1} signal. In a similar manner, M_nP_{WM2} and M_nP_{WM3} are produced from the *pwm1A'* and *pwm1B'* signals, M_nP_{WM4} and M_nP_{WM5} are produced from the *pwm2A'* and *pwm2B'* signals, and M_nP_{WM6} and M_nP_{WM7} are produced from the *pwm3A'* and *pwm3B'* signals.

If the Dead-Band Control mode is immediate (based on the **DBCTLUPD** field encoding in the **PWMnCTL** register), the **ENABLE** bit value is used immediately. If the update mode is locally synchronized, this value is used the next time the counter reaches zero. If the update mode is globally synchronized, this value is used the next time the counter reaches zero after a synchronous update has been requested through the **PWM Master Control (PWMCTL)** register (see page 1203). If this register is rewritten before the actual update occurs, the previous value is never used and is lost.

PWMn Dead-Band Control (PWMnDBCTL)

PWM0 base: 0x4002.8000
 PWM1 base: 0x4002.9000
 Offset 0x068
 Type R/W, reset 0x0000.0000

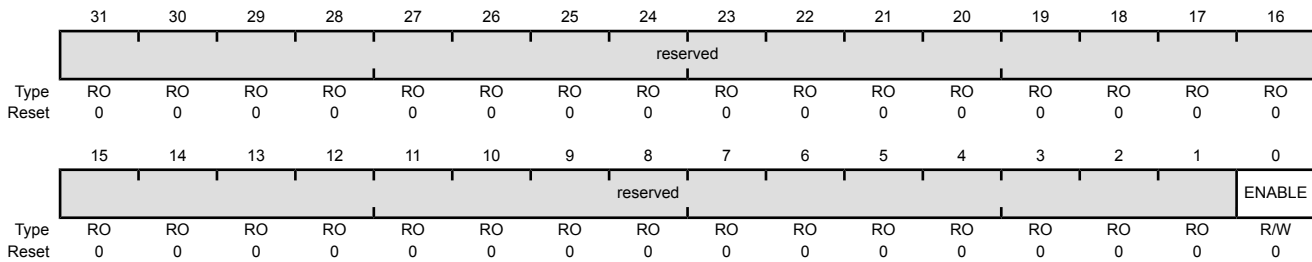

Bit/Field	Name	Type	Reset	Description
31:1	reserved	RO	0x0000.000	Software should not rely on the value of a reserved bit. To provide compatibility with future products, the value of a reserved bit should be preserved across a read-modify-write operation.
0	ENABLE	R/W	0	Dead-Band Generator Enable

Value	Description
1	The dead-band generator modifies the <i>pwmA</i> signal by inserting dead bands into the <i>pwmA'</i> and <i>pwmB'</i> signals.
0	The <i>pwmA</i> and <i>pwmB</i> signals pass through to the <i>pwmA'</i> and <i>pwmB'</i> signals unmodified.

Register 56: PWM0 Dead-Band Rising-Edge Delay (PWM0DBRISE), offset 0x06C

Register 57: PWM1 Dead-Band Rising-Edge Delay (PWM1DBRISE), offset 0x0AC

Register 58: PWM2 Dead-Band Rising-Edge Delay (PWM2DBRISE), offset 0x0EC

Register 59: PWM3 Dead-Band Rising-Edge Delay (PWM3DBRISE), offset 0x12C

The **PWMnDBRISE** register contains the number of clock cycles to delay the rising edge of the pwmA signal when generating the pwmA' signal. If the dead-band generator is disabled through the **PWMnDBCTL** register, this register is ignored. If the value of this register is larger than the width of a High pulse on the pwmA signal, the rising-edge delay consumes the entire High time of the signal, resulting in no High time on the output. Care must be taken to ensure that the pwmA High time always exceeds the rising-edge delay.

If the Dead-Band Rising-Edge Delay mode is immediate (based on the **DBRISEUPD** field encoding in the **PWMnCTL** register), the 12-bit **RISEDELAY** value is used immediately. If the update mode is locally synchronized, this value is used the next time the counter reaches zero. If the update mode is globally synchronized, this value is used the next time the counter reaches zero after a synchronous update has been requested through the **PWM Master Control (PWMCTL)** register (see page 1203). If this register is rewritten before the actual update occurs, the previous value is never used and is lost.

PWMn Dead-Band Rising-Edge Delay (PWMnDBRISE)

PWM0 base: 0x4002.8000
 PWM1 base: 0x4002.9000
 Offset 0x06C
 Type R/W, reset 0x0000.0000

	31	30	29	28	27	26	25	24	23	22	21	20	19	18	17	16
	reserved															
Type	RO	RO	RO	RO	RO	RO	RO	RO	RO	RO	RO	RO	RO	RO	RO	RO
Reset	0	0	0	0	0	0	0	0	0	0	0	0	0	0	0	0
	15	14	13	12	11	10	9	8	7	6	5	4	3	2	1	0
	reserved				RISEDELAY											
Type	RO	RO	RO	RO	R/W	R/W	R/W	R/W	R/W	R/W	R/W	R/W	R/W	R/W	R/W	R/W
Reset	0	0	0	0	0	0	0	0	0	0	0	0	0	0	0	0

Bit/Field	Name	Type	Reset	Description
31:12	reserved	RO	0x0000.0	Software should not rely on the value of a reserved bit. To provide compatibility with future products, the value of a reserved bit should be preserved across a read-modify-write operation.
11:0	RISEDELAY	R/W	0x000	Dead-Band Rise Delay The number of clock cycles to delay the rising edge of pwmA' after the rising edge of pwmA.

Register 60: PWM0 Dead-Band Falling-Edge-Delay (PWM0DBFALL), offset 0x070

Register 61: PWM1 Dead-Band Falling-Edge-Delay (PWM1DBFALL), offset 0x0B0

Register 62: PWM2 Dead-Band Falling-Edge-Delay (PWM2DBFALL), offset 0x0F0

Register 63: PWM3 Dead-Band Falling-Edge-Delay (PWM3DBFALL), offset 0x130

The **PWMnDBFALL** register contains the number of clock cycles to delay the rising edge of the pwmB' signal from the falling edge of the pwmA signal. If the dead-band generator is disabled through the **PWMnDBCTL** register, this register is ignored. If the value of this register is larger than the width of a Low pulse on the pwmA signal, the falling-edge delay consumes the entire Low time of the signal, resulting in no Low time on the output. Care must be taken to ensure that the pwmA Low time always exceeds the falling-edge delay.

If the Dead-Band Falling-Edge-Delay mode is immediate (based on the **DBFALLUP** field encoding in the **PWMnCTL** register), the 12-bit **FALLDELAY** value is used immediately. If the update mode is locally synchronized, this value is used the next time the counter reaches zero. If the update mode is globally synchronized, this value is used the next time the counter reaches zero after a synchronous update has been requested through the **PWM Master Control (PWMCTL)** register (see page 1203). If this register is rewritten before the actual update occurs, the previous value is never used and is lost.

PWMn Dead-Band Falling-Edge-Delay (PWMnDBFALL)

PWM0 base: 0x4002.8000
 PWM1 base: 0x4002.9000
 Offset 0x070
 Type R/W, reset 0x0000.0000

	31	30	29	28	27	26	25	24	23	22	21	20	19	18	17	16
	reserved															
Type	RO	RO	RO	RO	RO	RO	RO	RO	RO	RO	RO	RO	RO	RO	RO	RO
Reset	0	0	0	0	0	0	0	0	0	0	0	0	0	0	0	0
	15	14	13	12	11	10	9	8	7	6	5	4	3	2	1	0
	reserved				FALLDELAY											
Type	RO	RO	RO	RO	R/W	R/W	R/W	R/W	R/W	R/W	R/W	R/W	R/W	R/W	R/W	R/W
Reset	0	0	0	0	0	0	0	0	0	0	0	0	0	0	0	0

Bit/Field	Name	Type	Reset	Description
31:12	reserved	RO	0x0000.0	Software should not rely on the value of a reserved bit. To provide compatibility with future products, the value of a reserved bit should be preserved across a read-modify-write operation.
11:0	FALLDELAY	R/W	0x000	Dead-Band Fall Delay The number of clock cycles to delay the falling edge of pwmB' from the rising edge of pwmA.

Register 64: PWM0 Fault Source 0 (PWM0FLTSRC0), offset 0x074**Register 65: PWM1 Fault Source 0 (PWM1FLTSRC0), offset 0x0B4****Register 66: PWM2 Fault Source 0 (PWM2FLTSRC0), offset 0x0F4****Register 67: PWM3 Fault Source 0 (PWM3FLTSRC0), offset 0x134**

This register specifies which fault pin inputs are used to generate a fault condition. Each bit in the following register indicates whether the corresponding fault pin is included in the fault condition. All enabled fault pins are ORed together to form the **PWMnFLTSRC0** portion of the fault condition. The **PWMnFLTSRC0** fault condition is then ORed with the **PWMnFLTSRC1** fault condition to generate the final fault condition for the PWM generator.

If the **FLTSRC** bit in the **PWMnCTL** register (see page 1228) is clear, only the **Fault0** signal affects the fault condition generated. Otherwise, sources defined in **PWMnFLTSRC0** and **PWMnFLTSRC1** affect the fault condition generated.

PWMn Fault Source 0 (PWMnFLTSRC0)

PWM0 base: 0x4002.8000
 PWM1 base: 0x4002.9000
 Offset 0x074
 Type R/W, reset 0x0000.0000

	31	30	29	28	27	26	25	24	23	22	21	20	19	18	17	16
	reserved															
Type	RO	RO	RO	RO	RO	RO	RO	RO	RO	RO	RO	RO	RO	RO	RO	RO
Reset	0	0	0	0	0	0	0	0	0	0	0	0	0	0	0	0
	15	14	13	12	11	10	9	8	7	6	5	4	3	2	1	0
	reserved												FAULT3	FAULT2	FAULT1	FAULT0
Type	RO	RO	RO	RO	RO	RO	RO	RO	RO	RO	RO	RO	R/W	R/W	R/W	R/W
Reset	0	0	0	0	0	0	0	0	0	0	0	0	0	0	0	0

Bit/Field	Name	Type	Reset	Description
31:4	reserved	RO	0x0000	Software should not rely on the value of a reserved bit. To provide compatibility with future products, the value of a reserved bit should be preserved across a read-modify-write operation.
3	FAULT3	R/W	0	<p>Fault3 Input</p> <p>Value Description</p> <p>0 The Fault3 signal is suppressed and cannot generate a fault condition.</p> <p>1 The Fault3 signal value is ORed with all other fault condition generation inputs (Faultn signals and digital comparators).</p> <p>Note: The FLTSRC bit in the PWMnCTL register must be set for this bit to affect fault condition generation.</p>

Bit/Field	Name	Type	Reset	Description
2	FAULT2	R/W	0	<p>Fault2 Input</p> <p>Value Description</p> <p>0 The FAULT2 signal is suppressed and cannot generate a fault condition.</p> <p>1 The FAULT2 signal value is ORed with all other fault condition generation inputs (Faultn signals and digital comparators).</p> <p>Note: The FLTSRC bit in the PWMnCTL register must be set for this bit to affect fault condition generation.</p>
1	FAULT1	R/W	0	<p>Fault1 Input</p> <p>Value Description</p> <p>0 The FAULT1 signal is suppressed and cannot generate a fault condition.</p> <p>1 The FAULT1 signal value is ORed with all other fault condition generation inputs (Faultn signals and digital comparators).</p> <p>Note: The FLTSRC bit in the PWMnCTL register must be set for this bit to affect fault condition generation.</p>
0	FAULT0	R/W	0	<p>Fault0 Input</p> <p>Value Description</p> <p>0 The FAULT0 signal is suppressed and cannot generate a fault condition.</p> <p>1 The FAULT0 signal value is ORed with all other fault condition generation inputs (Faultn signals and digital comparators).</p> <p>Note: The FLTSRC bit in the PWMnCTL register must be set for this bit to affect fault condition generation.</p>

Register 68: PWM0 Fault Source 1 (PWM0FLTSRC1), offset 0x078**Register 69: PWM1 Fault Source 1 (PWM1FLTSRC1), offset 0x0B8****Register 70: PWM2 Fault Source 1 (PWM2FLTSRC1), offset 0x0F8****Register 71: PWM3 Fault Source 1 (PWM3FLTSRC1), offset 0x138**

This register specifies which digital comparator triggers from the ADC are used to generate a fault condition. Each bit in the following register indicates whether the corresponding digital comparator trigger is included in the fault condition. All enabled digital comparator triggers are ORed together to form the **PWMnFLTSRC1** portion of the fault condition. The **PWMnFLTSRC1** fault condition is then ORed with the **PWMnFLTSRC0** fault condition to generate the final fault condition for the PWM generator.

If the **FLTSRC** bit in the **PWMnCTL** register (see page 1228) is clear, only the PWM_{Fault0} pin affects the fault condition generated. Otherwise, sources defined in **PWMnFLTSRC0** and **PWMnFLTSRC1** affect the fault condition generated.

PWMn Fault Source 1 (PWMnFLTSRC1)

PWM0 base: 0x4002.8000
 PWM1 base: 0x4002.9000
 Offset 0x078
 Type R/W, reset 0x0000.0000

	31	30	29	28	27	26	25	24	23	22	21	20	19	18	17	16
	reserved															
Type	RO	RO	RO	RO	RO	RO	RO	RO	RO	RO	RO	RO	RO	RO	RO	RO
Reset	0	0	0	0	0	0	0	0	0	0	0	0	0	0	0	0
	15	14	13	12	11	10	9	8	7	6	5	4	3	2	1	0
	reserved								DCMP7	DCMP6	DCMP5	DCMP4	DCMP3	DCMP2	DCMP1	DCMP0
Type	RO	RO	RO	RO	RO	RO	RO	RO	R/W	R/W	R/W	R/W	R/W	R/W	R/W	R/W
Reset	0	0	0	0	0	0	0	0	0	0	0	0	0	0	0	0

Bit/Field	Name	Type	Reset	Description
31:8	reserved	RO	0x0000.00	Software should not rely on the value of a reserved bit. To provide compatibility with future products, the value of a reserved bit should be preserved across a read-modify-write operation.
7	DCMP7	R/W	0	Digital Comparator 7

Value	Description
0	The trigger from digital comparator 7 is suppressed and cannot generate a fault condition.
1	The trigger from digital comparator 7 is ORed with all other fault condition generation inputs (Faultn signals and digital comparators).

Note: The **FLTSRC** bit in the **PWMnCTL** register must be set for this bit to affect fault condition generation.

Bit/Field	Name	Type	Reset	Description
6	DCMP6	R/W	0	<p>Digital Comparator 6</p> <p>Value Description</p> <p>0 The trigger from digital comparator 6 is suppressed and cannot generate a fault condition.</p> <p>1 The trigger from digital comparator 6 is ORed with all other fault condition generation inputs (Faultn signals and digital comparators).</p> <p>Note: The FLTSRC bit in the PWMnCTL register must be set for this bit to affect fault condition generation.</p>
5	DCMP5	R/W	0	<p>Digital Comparator 5</p> <p>Value Description</p> <p>0 The trigger from digital comparator 5 is suppressed and cannot generate a fault condition.</p> <p>1 The trigger from digital comparator 5 is ORed with all other fault condition generation inputs (Faultn signals and digital comparators).</p> <p>Note: The FLTSRC bit in the PWMnCTL register must be set for this bit to affect fault condition generation.</p>
4	DCMP4	R/W	0	<p>Digital Comparator 4</p> <p>Value Description</p> <p>0 The trigger from digital comparator 4 is suppressed and cannot generate a fault condition.</p> <p>1 The trigger from digital comparator 4 is ORed with all other fault condition generation inputs (Faultn signals and digital comparators).</p> <p>Note: The FLTSRC bit in the PWMnCTL register must be set for this bit to affect fault condition generation.</p>
3	DCMP3	R/W	0	<p>Digital Comparator 3</p> <p>Value Description</p> <p>0 The trigger from digital comparator 3 is suppressed and cannot generate a fault condition.</p> <p>1 The trigger from digital comparator 3 is ORed with all other fault condition generation inputs (Faultn signals and digital comparators).</p> <p>Note: The FLTSRC bit in the PWMnCTL register must be set for this bit to affect fault condition generation.</p>

Bit/Field	Name	Type	Reset	Description
2	DCMP2	R/W	0	<p>Digital Comparator 2</p> <p>Value Description</p> <p>0 The trigger from digital comparator 2 is suppressed and cannot generate a fault condition.</p> <p>1 The trigger from digital comparator 2 is ORed with all other fault condition generation inputs (Faultn signals and digital comparators).</p> <p>Note: The FLTSRC bit in the PWMnCTL register must be set for this bit to affect fault condition generation.</p>
1	DCMP1	R/W	0	<p>Digital Comparator 1</p> <p>Value Description</p> <p>0 The trigger from digital comparator 1 is suppressed and cannot generate a fault condition.</p> <p>1 The trigger from digital comparator 1 is ORed with all other fault condition generation inputs (Faultn signals and digital comparators).</p> <p>Note: The FLTSRC bit in the PWMnCTL register must be set for this bit to affect fault condition generation.</p>
0	DCMP0	R/W	0	<p>Digital Comparator 0</p> <p>Value Description</p> <p>0 The trigger from digital comparator 0 is suppressed and cannot generate a fault condition.</p> <p>1 The trigger from digital comparator 0 is ORed with all other fault condition generation inputs (Faultn signals and digital comparators).</p> <p>Note: The FLTSRC bit in the PWMnCTL register must be set for this bit to affect fault condition generation.</p>

Register 72: PWM0 Minimum Fault Period (PWM0MINFLTPER), offset 0x07C

Register 73: PWM1 Minimum Fault Period (PWM1MINFLTPER), offset 0x0BC

Register 74: PWM2 Minimum Fault Period (PWM2MINFLTPER), offset 0x0FC

Register 75: PWM3 Minimum Fault Period (PWM3MINFLTPER), offset 0x13C

If the `MINFLTPER` bit in the `PWMnCTL` register is set, this register specifies the 16-bit time-extension value to be used in extending the fault condition. The value is loaded into a 16-bit down counter, and the counter value is used to extend the fault condition. The fault condition is released in the clock immediately after the counter value reaches 0. The fault condition is asynchronous to the PWM clock; and the delay value is the product of the PWM clock period and the (MFP field value + 1) or (MFP field value + 2) depending on when the fault condition asserts with respect to the PWM clock. The counter decrements at the PWM clock rate, without pause or condition.

PWMn Minimum Fault Period (PWMnMINFLTPER)

PWM0 base: 0x4002.8000
 PWM1 base: 0x4002.9000
 Offset 0x07C
 Type R/W, reset 0x0000.0000

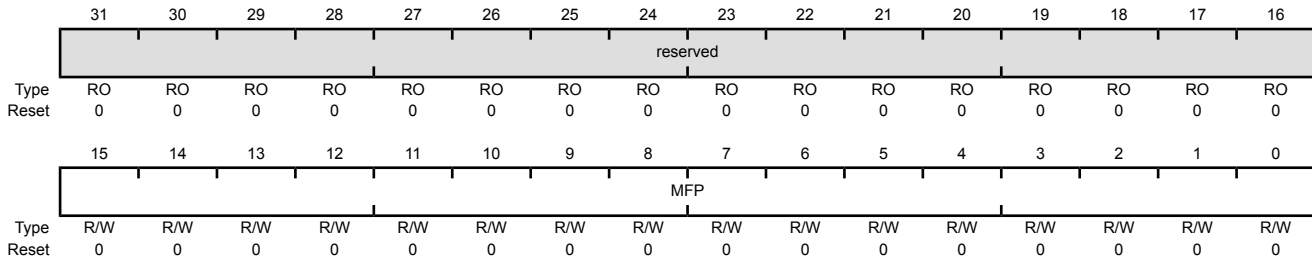

Bit/Field	Name	Type	Reset	Description
31:16	reserved	RO	0x0000	Software should not rely on the value of a reserved bit. To provide compatibility with future products, the value of a reserved bit should be preserved across a read-modify-write operation.
15:0	MFP	R/W	0x0000	Minimum Fault Period The number of PWM clocks by which a fault condition is extended when the delay is enabled by <code>PWMnCTL</code> <code>MINFLTPER</code> .

Register 76: PWM0 Fault Pin Logic Sense (PWM0FLTSEN), offset 0x800

Register 77: PWM1 Fault Pin Logic Sense (PWM1FLTSEN), offset 0x880

Register 78: PWM2 Fault Pin Logic Sense (PWM2FLTSEN), offset 0x900

Register 79: PWM3 Fault Pin Logic Sense (PWM3FLTSEN), offset 0x980

This register defines the PWM fault pin logic sense.

PWMn Fault Pin Logic Sense (PWMnFLTSEN)

PWM0 base: 0x4002.8000
 PWM1 base: 0x4002.9000
 Offset 0x800
 Type R/W, reset 0x0000.0000

	31	30	29	28	27	26	25	24	23	22	21	20	19	18	17	16	
	reserved																
Type	RO	RO	RO	RO	RO	RO	RO	RO	RO	RO	RO	RO	RO	RO	RO	RO	
Reset	0	0	0	0	0	0	0	0	0	0	0	0	0	0	0	0	
	15	14	13	12	11	10	9	8	7	6	5	4	3	2	1	0	
	reserved												FAULT3	FAULT2	FAULT1	FAULT0	
Type	RO	RO	RO	RO	RO	RO	RO	RO	RO	RO	RO	RO	RO	R/W	R/W	R/W	R/W
Reset	0	0	0	0	0	0	0	0	0	0	0	0	0	0	0	0	0

Bit/Field	Name	Type	Reset	Description
31:4	reserved	RO	0x0000.000	Software should not rely on the value of a reserved bit. To provide compatibility with future products, the value of a reserved bit should be preserved across a read-modify-write operation.
3	FAULT3	R/W	0	Fault3 Sense Value Description 0 An error is indicated if the <code>Fault3</code> signal is High. 1 An error is indicated if the <code>Fault3</code> signal is Low.
2	FAULT2	R/W	0	Fault2 Sense Value Description 0 An error is indicated if the <code>Fault2</code> signal is High. 1 An error is indicated if the <code>Fault2</code> signal is Low.
1	FAULT1	R/W	0	Fault1 Sense Value Description 0 An error is indicated if the <code>Fault1</code> signal is High. 1 An error is indicated if the <code>Fault1</code> signal is Low.
0	FAULT0	R/W	0	Fault0 Sense Value Description 0 An error is indicated if the <code>Fault0</code> signal is High. 1 An error is indicated if the <code>Fault0</code> signal is Low.

Register 80: PWM0 Fault Status 0 (PWM0FLTSTAT0), offset 0x804

Register 81: PWM1 Fault Status 0 (PWM1FLTSTAT0), offset 0x884

Register 82: PWM2 Fault Status 0 (PWM2FLTSTAT0), offset 0x904

Register 83: PWM3 Fault Status 0 (PWM3FLTSTAT0), offset 0x984

Along with the **PWMnFLTSTAT1** register, this register provides status regarding the fault condition inputs.

If the **LATCH** bit in the **PWMnCTL** register is clear, the contents of the **PWMnFLTSTAT0** register are read-only (RO) and provide the current state of the **MnFAULTn** inputs.

If the **LATCH** bit in the **PWMnCTL** register is set, the contents of the **PWMnFLTSTAT0** register are read / write 1 to clear (R/W1C) and provide a latched version of the **MnFAULTn** inputs. In this mode, the register bits are cleared by writing a 1 to a set bit. The **MnFAULTn** inputs are recorded after their sense is adjusted in the generator.

The contents of this register can only be written if the fault source extensions are enabled (the **FLTSRC** bit in the **PWMnCTL** register is set).

PWMn Fault Status 0 (PWMnFLTSTAT0)

PWM0 base: 0x4002.8000
 PWM1 base: 0x4002.9000
 Offset 0x804
 Type -, reset 0x0000.0000

	31	30	29	28	27	26	25	24	23	22	21	20	19	18	17	16	
	reserved																
Type	RO	RO	RO	RO	RO	RO	RO	RO	RO	RO	RO	RO	RO	RO	RO	RO	
Reset	0	0	0	0	0	0	0	0	0	0	0	0	0	0	0	0	
	15	14	13	12	11	10	9	8	7	6	5	4	3	2	1	0	
	reserved													FAULT3	FAULT2	FAULT1	FAULT0
Type	RO	RO	RO	RO	RO	RO	RO	RO	RO	RO	RO	RO	RO	-	-	-	-
Reset	0	0	0	0	0	0	0	0	0	0	0	0	0	0	0	0	0

Bit/Field	Name	Type	Reset	Description
31:4	reserved	RO	0x0000	Software should not rely on the value of a reserved bit. To provide compatibility with future products, the value of a reserved bit should be preserved across a read-modify-write operation.
3	FAULT3	-	0	<p>Fault Input 3</p> <p>If the PWMnCTL register LATCH bit is clear, this bit is RO and represents the current state of the MnFAULT3 input signal after the logic sense adjustment.</p> <p>If the PWMnCTL register LATCH bit is set, this bit is R/W1C and represents a sticky version of the MnFAULT3 input signal after the logic sense adjustment.</p> <ul style="list-style-type: none"> ■ If FAULT3 is set, the input transitioned to the active state previously. ■ If FAULT3 is clear, the input has not transitioned to the active state since the last time it was cleared. ■ The FAULT3 bit is cleared by writing it with the value 1.

Bit/Field	Name	Type	Reset	Description
2	FAULT2	-	0	<p>Fault Input 2</p> <p>If the PWMnCTL register LATCH bit is clear, this bit is RO and represents the current state of the MnFAULT2 input signal after the logic sense adjustment.</p> <p>If the PWMnCTL register LATCH bit is set, this bit is R/W1C and represents a sticky version of the MnFAULT2 input signal after the logic sense adjustment.</p> <ul style="list-style-type: none"> ■ If FAULT2 is set, the input transitioned to the active state previously. ■ If FAULT2 is clear, the input has not transitioned to the active state since the last time it was cleared. ■ The FAULT2 bit is cleared by writing it with the value 1.
1	FAULT1	-	0	<p>Fault Input 1</p> <p>If the PWMnCTL register LATCH bit is clear, this bit is RO and represents the current state of the MnFAULT1 input signal after the logic sense adjustment.</p> <p>If the PWMnCTL register LATCH bit is set, this bit is R/W1C and represents a sticky version of the MnFAULT1 input signal after the logic sense adjustment.</p> <ul style="list-style-type: none"> ■ If FAULT1 is set, the input transitioned to the active state previously. ■ If FAULT1 is clear, the input has not transitioned to the active state since the last time it was cleared. ■ The FAULT1 bit is cleared by writing it with the value 1.
0	FAULT0	-	0	<p>Fault Input 0</p> <p>If the PWMnCTL register LATCH bit is clear, this bit is RO and represents the current state of the input signal after the logic sense adjustment.</p> <p>If the PWMnCTL register LATCH bit is set, this bit is R/W1C and represents a sticky version of the input signal after the logic sense adjustment.</p> <ul style="list-style-type: none"> ■ If FAULT0 is set, the input transitioned to the active state previously. ■ If FAULT0 is clear, the input has not transitioned to the active state since the last time it was cleared. ■ The FAULT0 bit is cleared by writing it with the value 1.

Register 84: PWM0 Fault Status 1 (PWM0FLTSTAT1), offset 0x808

Register 85: PWM1 Fault Status 1 (PWM1FLTSTAT1), offset 0x888

Register 86: PWM2 Fault Status 1 (PWM2FLTSTAT1), offset 0x908

Register 87: PWM3 Fault Status 1 (PWM3FLTSTAT1), offset 0x988

Along with the **PWMnFLTSTAT0** register, this register provides status regarding the fault condition inputs.

If the **LATCH** bit in the **PWMnCTL** register is clear, the contents of the **PWMnFLTSTAT1** register are read-only (RO) and provide the current state of the digital comparator triggers.

If the **LATCH** bit in the **PWMnCTL** register is set, the contents of the **PWMnFLTSTAT1** register are read / write 1 to clear (R/W1C) and provide a latched version of the digital comparator triggers. In this mode, the register bits are cleared by writing a 1 to a set bit. The contents of this register can only be written if the fault source extensions are enabled (the **FLTSRC** bit in the **PWMnCTL** register is set).

PWMn Fault Status 1 (PWMnFLTSTAT1)

PWM0 base: 0x4002.8000
 PWM1 base: 0x4002.9000
 Offset 0x808
 Type -, reset 0x0000.0000

	31	30	29	28	27	26	25	24	23	22	21	20	19	18	17	16
	reserved															
Type	RO	RO	RO	RO	RO	RO	RO	RO	RO	RO	RO	RO	RO	RO	RO	RO
Reset	0	0	0	0	0	0	0	0	0	0	0	0	0	0	0	0
	15	14	13	12	11	10	9	8	7	6	5	4	3	2	1	0
	reserved								DCMP7	DCMP6	DCMP5	DCMP4	DCMP3	DCMP2	DCMP1	DCMP0
Type	RO	RO	RO	RO	RO	RO	RO	RO	-	-	-	-	-	-	-	-
Reset	0	0	0	0	0	0	0	0	0	0	0	0	0	0	0	0

Bit/Field	Name	Type	Reset	Description
31:8	reserved	RO	0x0000.00	Software should not rely on the value of a reserved bit. To provide compatibility with future products, the value of a reserved bit should be preserved across a read-modify-write operation.
7	DCMP7	-	0	Digital Comparator 7 Trigger If the PWMnCTL register LATCH bit is clear, this bit represents the current state of the Digital Comparator 7 trigger input. If the PWMnCTL register LATCH bit is set, this bit represents a sticky version of the trigger. <ul style="list-style-type: none"> ■ If DCMP7 is set, the trigger transitioned to the active state previously. ■ If DCMP7 is clear, the trigger has not transitioned to the active state since the last time it was cleared. ■ The DCMP7 bit is cleared by writing it with the value 1.

Bit/Field	Name	Type	Reset	Description
6	DCMP6	-	0	<p>Digital Comparator 6 Trigger</p> <p>If the PWMnCTL register <i>LATCH</i> bit is clear, this bit represents the current state of the Digital Comparator 6 trigger input.</p> <p>If the PWMnCTL register <i>LATCH</i> bit is set, this bit represents a sticky version of the trigger.</p> <ul style="list-style-type: none"> ■ If DCMP6 is set, the trigger transitioned to the active state previously. ■ If DCMP6 is clear, the trigger has not transitioned to the active state since the last time it was cleared. ■ The DCMP6 bit is cleared by writing it with the value 1.
5	DCMP5	-	0	<p>Digital Comparator 5 Trigger</p> <p>If the PWMnCTL register <i>LATCH</i> bit is clear, this bit represents the current state of the Digital Comparator 5 trigger input.</p> <p>If the PWMnCTL register <i>LATCH</i> bit is set, this bit represents a sticky version of the trigger.</p> <ul style="list-style-type: none"> ■ If DCMP5 is set, the trigger transitioned to the active state previously. ■ If DCMP5 is clear, the trigger has not transitioned to the active state since the last time it was cleared. ■ The DCMP5 bit is cleared by writing it with the value 1.
4	DCMP4	-	0	<p>Digital Comparator 4 Trigger</p> <p>If the PWMnCTL register <i>LATCH</i> bit is clear, this bit represents the current state of the Digital Comparator 4 trigger input.</p> <p>If the PWMnCTL register <i>LATCH</i> bit is set, this bit represents a sticky version of the trigger.</p> <ul style="list-style-type: none"> ■ If DCMP4 is set, the trigger transitioned to the active state previously. ■ If DCMP4 is clear, the trigger has not transitioned to the active state since the last time it was cleared. ■ The DCMP4 bit is cleared by writing it with the value 1.
3	DCMP3	-	0	<p>Digital Comparator 3 Trigger</p> <p>If the PWMnCTL register <i>LATCH</i> bit is clear, this bit represents the current state of the Digital Comparator 3 trigger input.</p> <p>If the PWMnCTL register <i>LATCH</i> bit is set, this bit represents a sticky version of the trigger.</p> <ul style="list-style-type: none"> ■ If DCMP3 is set, the trigger transitioned to the active state previously. ■ If DCMP3 is clear, the trigger has not transitioned to the active state since the last time it was cleared. ■ The DCMP3 bit is cleared by writing it with the value 1.

Bit/Field	Name	Type	Reset	Description
2	DCMP2	-	0	<p>Digital Comparator 2 Trigger</p> <p>If the PWMnCTL register LATCH bit is clear, this bit represents the current state of the Digital Comparator 2 trigger input.</p> <p>If the PWMnCTL register LATCH bit is set, this bit represents a sticky version of the trigger.</p> <ul style="list-style-type: none">■ If DCMP2 is set, the trigger transitioned to the active state previously.■ If DCMP2 is clear, the trigger has not transitioned to the active state since the last time it was cleared.■ The DCMP2 bit is cleared by writing it with the value 1.
1	DCMP1	-	0	<p>Digital Comparator 1 Trigger</p> <p>If the PWMnCTL register LATCH bit is clear, this bit represents the current state of the Digital Comparator 1 trigger input.</p> <p>If the PWMnCTL register LATCH bit is set, this bit represents a sticky version of the trigger.</p> <ul style="list-style-type: none">■ If DCMP1 is set, the trigger transitioned to the active state previously.■ If DCMP1 is clear, the trigger has not transitioned to the active state since the last time it was cleared.■ The DCMP1 bit is cleared by writing it with the value 1.
0	DCMP0	-	0	<p>Digital Comparator 0 Trigger</p> <p>If the PWMnCTL register LATCH bit is clear, this bit represents the current state of the Digital Comparator 0 trigger input.</p> <p>If the PWMnCTL register LATCH bit is set, this bit represents a sticky version of the trigger.</p> <ul style="list-style-type: none">■ If DCMP0 is set, the trigger transitioned to the active state previously.■ If DCMP0 is clear, the trigger has not transitioned to the active state since the last time it was cleared.■ The DCMP0 bit is cleared by writing it with the value 1.

Register 88: PWM Peripheral Properties (PWMPP), offset 0xFC0

The **PWMPP** register provides information regarding the properties of the PWM module.

PWM Peripheral Properties (PWMPP)

PWM0 base: 0x4002.8000
 PWM1 base: 0x4002.9000
 Offset 0xFC0
 Type RO, reset 0x0000.0334

	31	30	29	28	27	26	25	24	23	22	21	20	19	18	17	16
	reserved															
Type	RO	RO	RO	RO	RO	RO	RO	RO	RO	RO	RO	RO	RO	RO	RO	RO
Reset	0	0	0	0	0	0	0	0	0	0	0	0	0	0	0	0
	15	14	13	12	11	10	9	8	7	6	5	4	3	2	1	0
	reserved				ONE	EFAULT	ESYNC	FCNT				GCNT				
Type	RO	RO	RO	RO	RO	RO	RO	RO	RO	RO	RO	RO	RO	RO	RO	RO
Reset	0	0	0	0	0	0	1	1	0	0	1	1	0	1	0	0

Bit/Field	Name	Type	Reset	Description
31:11	reserved	RO	0x0	Software should not rely on the value of a reserved bit. To provide compatibility with future products, the value of a reserved bit should be preserved across a read-modify-write operation.
10	ONE	RO	0x0	One-Shot Mode Value Description 1 One-shot modes are available. 0 One-shot modes are not available.
9	EFAULT	RO	0x1	Extended Fault Value Description 1 Extended fault capabilities are available. 0 Extended fault capabilities are not available.
8	ESYNC	RO	0x1	Extended Synchronization Value Description 1 Extended synchronization is available. 0 Extended synchronization is not available.
7:4	FCNT	RO	0x3	Fault Inputs Value Description 0x0 No fault inputs. 0x1 1 fault input. 0x2 2 fault input. 0x3 3 fault input. 0x4 4 fault input. 0x5 - 0xF reserved

Bit/Field	Name	Type	Reset	Description
3:0	GCNT	RO	0x4	Generators

Value	Description
0x0	No generators.
0x1	1 generator
0x2	2 generators
0x3	3 generators
0x4	4 generators
0x5 - 0xF	reserved

The number of PWM outputs is 2 times the number of PWM generators.

Register 89: PWM Peripheral Configuration (PWMPFC), offset 0xFC4

The **PWMPFC** register provides information regarding the configuration of the PWM module..

PWM Peripheral Configuration (PWMPFC)

PWM0 base: 0x4002.8000
 PWM1 base: 0x4002.9000
 Offset 0xFC4
 Type R/W, reset 0x0000.0000

	31	30	29	28	27	26	25	24	23	22	21	20	19	18	17	16
	reserved															
Type	RO	RO	RO	RO	RO	RO	RO	RO	RO	RO	RO	RO	RO	RO	RO	RO
Reset	0	0	0	0	0	0	0	0	0	0	0	0	0	0	0	0
	15	14	13	12	11	10	9	8	7	6	5	4	3	2	1	0
	reserved							USEPWMDIV	PWMDIV							
Type	RO	RO	RO	RO	RO	RO	RO	R/W	R/W	R/W	R/W	R/W	R/W	R/W	R/W	R/W
Reset	0	0	0	0	0	0	0	0	0	0	0	0	0	1	1	1

Bit/Field	Name	Type	Reset	Description																				
31:9	reserved	RO	0x0000.0	Software should not rely on the value of a reserved bit. To provide compatibility with future products, the value of a reserved bit should be preserved across a read-modify-write operation.																				
8	USEPWMDIV	R/W	0	<p>Enable PWM Clock Divisor</p> <table border="1"> <thead> <tr> <th>Value</th> <th>Description</th> </tr> </thead> <tbody> <tr> <td>1</td> <td>The PWM clock divider is the source for the PWM clock.</td> </tr> <tr> <td>0</td> <td>The system clock is the source for the PWM clock.</td> </tr> </tbody> </table> <p>This bit has the same function as the legacy <code>USEPWMDIV</code> bit in the RCC register.</p>	Value	Description	1	The PWM clock divider is the source for the PWM clock.	0	The system clock is the source for the PWM clock.														
Value	Description																							
1	The PWM clock divider is the source for the PWM clock.																							
0	The system clock is the source for the PWM clock.																							
7:0	PWMDIV	R/W	0x7	<p>PWM Clock Divisor</p> <p>This field specifies the binary divisor used to predivide the system clock down for use as the timing reference for the PWM module. The rising edge of this clock is synchronous with the system clock.</p> <table border="1"> <thead> <tr> <th>Value</th> <th>Description</th> </tr> </thead> <tbody> <tr> <td>0x0</td> <td>/2</td> </tr> <tr> <td>0x1</td> <td>/4</td> </tr> <tr> <td>0x2</td> <td>/8</td> </tr> <tr> <td>0x3</td> <td>/16</td> </tr> <tr> <td>0x4</td> <td>/32</td> </tr> <tr> <td>0x5</td> <td>/64</td> </tr> <tr> <td>0x6</td> <td>/64</td> </tr> <tr> <td>0x7</td> <td>/64 (default)</td> </tr> <tr> <td>0x8 - 0xF</td> <td>reserved</td> </tr> </tbody> </table> <p>This bit has the same function as the legacy <code>PWMDIV</code> bit in the RCC register.</p>	Value	Description	0x0	/2	0x1	/4	0x2	/8	0x3	/16	0x4	/32	0x5	/64	0x6	/64	0x7	/64 (default)	0x8 - 0xF	reserved
Value	Description																							
0x0	/2																							
0x1	/4																							
0x2	/8																							
0x3	/16																							
0x4	/32																							
0x5	/64																							
0x6	/64																							
0x7	/64 (default)																							
0x8 - 0xF	reserved																							

20 Quadrature Encoder Interface (QEI)

A quadrature encoder, also known as a 2-channel incremental encoder, converts linear displacement into a pulse signal. By monitoring both the number of pulses and the relative phase of the two signals, you can track the position, direction of rotation, and speed. In addition, a third channel, or index signal, can be used to reset the position counter.

The LM4F231H5QR microcontroller includes two quadrature encoder interface (QEI) modules. Each QEI module interprets the code produced by a quadrature encoder wheel to integrate position over time and determine direction of rotation. In addition, it can capture a running estimate of the velocity of the encoder wheel.

The Stellaris[®] LM4F231H5QR microcontroller includes two QEI modules providing control of two motors at the same time with the following features:

- Position integrator that tracks the encoder position
- Programmable noise filter on the inputs
- Velocity capture using built-in timer
- The input frequency of the QEI inputs may be as high as 1/4 of the processor frequency (for example, 12.5 MHz for a 50-MHz system)
- Interrupt generation on:
 - Index pulse
 - Velocity-timer expiration
 - Direction change
 - Quadrature error detection

20.1 Block Diagram

Figure 20-1 on page 1269 provides a block diagram of a Stellaris QEI module.

Figure 20-1. QEI Block Diagram

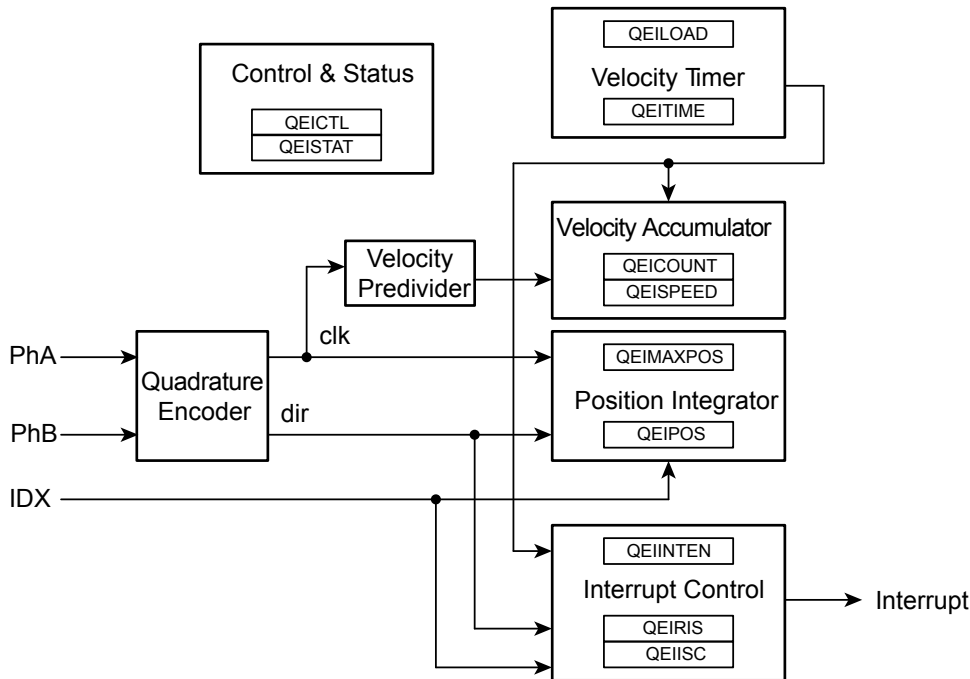

20.2 Signal Description

The following table lists the external signals of the QEI module and describes the function of each. The QEI signals are alternate functions for some GPIO signals and default to be GPIO signals at reset. The column in the table below titled "Pin Mux/Pin Assignment" lists the possible GPIO pin placements for these QEI signals. The `AFSEL` bit in the **GPIO Alternate Function Select (GPIOAFSEL)** register (page 644) should be set to choose the QEI function. The number in parentheses is the encoding that must be programmed into the `PMCn` field in the **GPIO Port Control (GPIOPCTL)** register (page 661) to assign the QEI signal to the specified GPIO port pin. For more information on configuring GPIOs, see "General-Purpose Input/Outputs (GPIOs)" on page 623.

Table 20-1. QEI Signals (64LQFP)

Pin Name	Pin Number	Pin Mux / Pin Assignment	Pin Type	Buffer Type ^a	Description
IDX0	5 64	PF4 (6) PD3 (6)	I	TTL	QEI module 0 index.
IDX1	16 32	PC4 (6) PG5 (6)	I	TTL	QEI module 1 index.
PhA0	28 53	PF0 (6) PD6 (6)	I	TTL	QEI module 0 phase A.
PhA1	15 34 37	PC5 (6) PG3 (6) PG0 (6)	I	TTL	QEI module 1 phase A.
PhB0	10 29	PD7 (6) PF1 (6)	I	TTL	QEI module 0 phase B.

Table 20-1. QEI Signals (64LQFP) (continued)

Pin Name	Pin Number	Pin Mux / Pin Assignment	Pin Type	Buffer Type ^a	Description
PhB1	14	PC6 (6)	I	TTL	QEI module 1 phase B.
	33	PG4 (6)			
	36	PG1 (6)			

a. The TTL designation indicates the pin has TTL-compatible voltage levels.

20.3 Functional Description

The QEI module interprets the two-bit gray code produced by a quadrature encoder wheel to integrate position over time and determine direction of rotation. In addition, it can capture a running estimate of the velocity of the encoder wheel.

The position integrator and velocity capture can be independently enabled, though the position integrator must be enabled before the velocity capture can be enabled. The two phase signals, PhA and PhB , can be swapped before being interpreted by the QEI module to change the meaning of forward and backward and to correct for miswiring of the system. Alternatively, the phase signals can be interpreted as a clock and direction signal as output by some encoders.

The QEI module input signals have a digital noise filter on them that can be enabled to prevent spurious operation. The noise filter requires that the inputs be stable for a specified number of consecutive clock cycles before updating the edge detector. The filter is enabled by the `FILTEN` bit in the **QEI Control (QEICTL)** register. The frequency of the input update is programmable using the `FILTCNT` bit field in the **QEICTL** register.

The QEI module supports two modes of signal operation: quadrature phase mode and clock/direction mode. In quadrature phase mode, the encoder produces two clocks that are 90 degrees out of phase; the edge relationship is used to determine the direction of rotation. In clock/direction mode, the encoder produces a clock signal to indicate steps and a direction signal to indicate the direction of rotation. This mode is determined by the `SIGMODE` bit of the **QEICTL** register (see page 1274).

When the QEI module is set to use the quadrature phase mode (`SIGMODE` bit is clear), the capture mode for the position integrator can be set to update the position counter on every edge of the PhA signal or to update on every edge of both PhA and PhB . Updating the position counter on every PhA and PhB edge provides more positional resolution at the cost of less range in the positional counter.

When edges on PhA lead edges on PhB , the position counter is incremented. When edges on PhB lead edges on PhA , the position counter is decremented. When a rising and falling edge pair is seen on one of the phases without any edges on the other, the direction of rotation has changed.

The positional counter is automatically reset on one of two conditions: sensing the index pulse or reaching the maximum position value. The reset mode is determined by the `RESMODE` bit of the **QEICTL** register.

When `RESMODE` is set, the positional counter is reset when the index pulse is sensed. This mode limits the positional counter to the values $[0:N-1]$, where N is the number of phase edges in a full revolution of the encoder wheel. The **QEI Maximum Position (QEIMAXPOS)** register must be programmed with $N-1$ so that the reverse direction from position 0 can move the position counter to $N-1$. In this mode, the position register contains the absolute position of the encoder relative to the index (or home) position once an index pulse has been seen.

When `RESMODE` is clear, the positional counter is constrained to the range $[0:M]$, where M is the programmable maximum value. The index pulse is ignored by the positional counter in this mode.

Velocity capture uses a configurable timer and a count register. The timer counts the number of phase edges (using the same configuration as for the position integrator) in a given time period. The edge count from the previous time period is available to the controller via the **QEI Velocity (QEISPEED)** register, while the edge count for the current time period is being accumulated in the **QEI Velocity Counter (QEICOUNT)** register. As soon as the current time period is complete, the total number of edges counted in that time period is made available in the **QEISPEED** register (overwriting the previous value), the **QEICOUNT** register is cleared, and counting commences on a new time period. The number of edges counted in a given time period is directly proportional to the velocity of the encoder.

Figure 20-2 on page 1271 shows how the Stellaris quadrature encoder converts the phase input signals into clock pulses, the direction signal, and how the velocity predivider operates (in Divide by 4 mode).

Figure 20-2. Quadrature Encoder and Velocity Predivider Operation

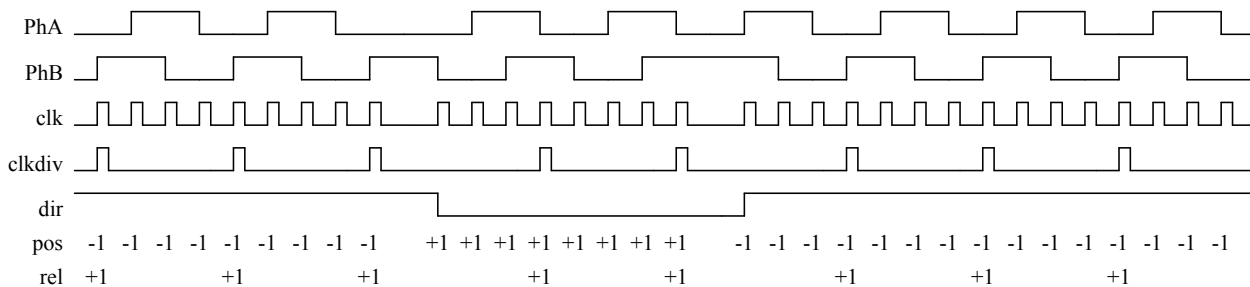

The period of the timer is configurable by specifying the load value for the timer in the **QEI Timer Load (QEILOAD)** register. When the timer reaches zero, an interrupt can be triggered, and the hardware reloads the timer with the **QEILOAD** value and continues to count down. At lower encoder speeds, a longer timer period is required to be able to capture enough edges to have a meaningful result. At higher encoder speeds, both a shorter timer period and/or the velocity predivider can be used.

The following equation converts the velocity counter value into an rpm value:

$$\text{rpm} = (\text{clock} * (2 \wedge \text{VELDIV}) * \text{SPEED} * 60) \div (\text{LOAD} * \text{ppr} * \text{edges})$$

where:

clock is the controller clock rate

ppr is the number of pulses per revolution of the physical encoder

edges is 2 or 4, based on the capture mode set in the **QEICTL** register (2 for CAPMODE clear and 4 for CAPMODE set)

For example, consider a motor running at 600 rpm. A 2048 pulse per revolution quadrature encoder is attached to the motor, producing 8192 phase edges per revolution. With a velocity predivider of ÷1 (VELDIV is clear) and clocking on both PhA and PhB edges, this results in 81,920 pulses per second (the motor turns 10 times per second). If the timer were clocked at 10,000 Hz, and the load value was 2,500 (¼ of a second), it would count 20,480 pulses per update. Using the above equation:

$$\text{rpm} = (10000 * 1 * 20480 * 60) \div (2500 * 2048 * 4) = 600 \text{ rpm}$$

Now, consider that the motor is sped up to 3000 rpm. This results in 409,600 pulses per second, or 102,400 every ¼ of a second. Again, the above equation gives:

$$\text{rpm} = (10000 * 1 * 102400 * 60) \div (2500 * 2048 * 4) = 3000 \text{ rpm}$$

Care must be taken when evaluating this equation because intermediate values may exceed the capacity of a 32-bit integer. In the above examples, the clock is 10,000 and the divider is 2,500; both could be predivided by 100 (at compile time if they are constants) and therefore be 100 and 25. In fact, if they were compile-time constants, they could also be reduced to a simple multiply by 4, cancelled by the $\div 4$ for the edge-count factor.

Important: Reducing constant factors at compile time is the best way to control the intermediate values of this equation and reduce the processing requirement of computing this equation.

The division can be avoided by selecting a timer load value such that the divisor is a power of 2; a simple shift can therefore be done in place of the division. For encoders with a power of 2 pulses per revolution, the load value can be a power of 2. For other encoders, a load value must be selected such that the product is very close to a power of 2. For example, a 100 pulse-per-revolution encoder could use a load value of 82, resulting in 32,800 as the divisor, which is 0.09% above 2^{14} . In this case a shift by 15 would be an adequate approximation of the divide in most cases. If absolute accuracy were required, the microcontroller's divide instruction could be used.

The QEI module can produce a controller interrupt on several events: phase error, direction change, reception of the index pulse, and expiration of the velocity timer. Standard masking, raw interrupt status, interrupt status, and interrupt clear capabilities are provided.

20.4 Initialization and Configuration

The following example shows how to configure the Quadrature Encoder module to read back an absolute position:

1. Enable the QEI clock using the **RCGCQEI** register in the System Control module (see page 333).
2. Enable the clock to the appropriate GPIO module via the **RCGCGPIO** register in the System Control module (see page 319).
3. In the GPIO module, enable the appropriate pins for their alternate function using the **GPIOAFSEL** register. To determine which GPIOs to configure, see Table 22-4 on page 1307.
4. Configure the **PMC_n** fields in the **GPIOPCTL** register to assign the QEI signals to the appropriate pins (see page 661 and Table 22-5 on page 1314).
5. Configure the quadrature encoder to capture edges on both signals and maintain an absolute position by resetting on index pulses. A 1000-line encoder with four edges per line, results in 4000 pulses per revolution; therefore, set the maximum position to 3999 (0xF9F) as the count is zero-based.
 - Write the **QEICTL** register with the value of 0x0000.0018.
 - Write the **QEIMAXPOS** register with the value of 0x0000.0F9F.
6. Enable the quadrature encoder by setting bit 0 of the **QEICTL** register.
7. Delay until the encoder position is required.
8. Read the encoder position by reading the **QEI Position (QEIPOS)** register value.

20.5 Register Map

Table 20-2 on page 1273 lists the QEI registers. The offset listed is a hexadecimal increment to the register's address, relative to the module's base address:

- QEI0: 0x4002.C000
- QEI1: 0x4002.D000

Note that the QEI module clock must be enabled before the registers can be programmed (see page 333). There must be a delay of 3 system clocks after the QEI module clock is enabled before any QEI module registers are accessed.

Table 20-2. QEI Register Map

Offset	Name	Type	Reset	Description	See page
0x000	QEICTL	R/W	0x0000.0000	QEI Control	1274
0x004	QEISTAT	RO	0x0000.0000	QEI Status	1277
0x008	QEIPOS	R/W	0x0000.0000	QEI Position	1278
0x00C	QEIMAXPOS	R/W	0x0000.0000	QEI Maximum Position	1279
0x010	QEILOAD	R/W	0x0000.0000	QEI Timer Load	1280
0x014	QEITIME	RO	0x0000.0000	QEI Timer	1281
0x018	QEICOUNT	RO	0x0000.0000	QEI Velocity Counter	1282
0x01C	QEISPEED	RO	0x0000.0000	QEI Velocity	1283
0x020	QEIINTEN	R/W	0x0000.0000	QEI Interrupt Enable	1284
0x024	QEIRIS	RO	0x0000.0000	QEI Raw Interrupt Status	1286
0x028	QEIISC	R/W1C	0x0000.0000	QEI Interrupt Status and Clear	1288

20.6 Register Descriptions

The remainder of this section lists and describes the QEI registers, in numerical order by address offset.

Register 1: QEI Control (QEICTL), offset 0x000

This register contains the configuration of the QEI module. Separate enables are provided for the quadrature encoder and the velocity capture blocks; the quadrature encoder must be enabled in order to capture the velocity, but the velocity does not need to be captured in applications that do not need it. The phase signal interpretation, phase swap, Position Update mode, Position Reset mode, and velocity predivider are all set via this register.

QEI Control (QEICTL)

QEI0 base: 0x4002.C000
 QEI1 base: 0x4002.D000
 Offset 0x000
 Type R/W, reset 0x0000.0000

	31	30	29	28	27	26	25	24	23	22	21	20	19	18	17	16
	reserved												FILTCNT			
Type	RO	RO	RO	RO	RO	RO	RO	RO	RO	RO	RO	RO	R/W	R/W	R/W	R/W
Reset	0	0	0	0	0	0	0	0	0	0	0	0	0	0	0	0
	15	14	13	12	11	10	9	8	7	6	5	4	3	2	1	0
	reserved		FILTEN	STALLEN	INVI	INVB	INVA	VELDIV			VELEN	RESMODE	CAPMODE	SIGMODE	SWAP	ENABLE
Type	RO	RO	R/W	R/W	R/W	R/W	R/W	R/W	R/W	R/W	R/W	R/W	R/W	R/W	R/W	R/W
Reset	0	0	0	0	0	0	0	0	0	0	0	0	0	0	0	0

Bit/Field	Name	Type	Reset	Description
31:20	reserved	RO	0x000	Software should not rely on the value of a reserved bit. To provide compatibility with future products, the value of a reserved bit should be preserved across a read-modify-write operation.
19:16	FILTCNT	R/W	0x0	Input Filter Prescale Count This field controls the frequency of the input update. When this field is clear, the input is sampled after 2 system clocks. When this field is 0x1, the input is sampled after 3 system clocks. Similarly, when this field is 0xF, the input is sampled after 17 clocks.
15:14	reserved	RO	0x0	Software should not rely on the value of a reserved bit. To provide compatibility with future products, the value of a reserved bit should be preserved across a read-modify-write operation.
13	FILTEN	R/W	0	Enable Input Filter Value Description 0 The QEI inputs are not filtered. 1 Enables the digital noise filter on the QEI input signals. Inputs must be stable for 3 consecutive clock edges before the edge detector is updated.
12	STALLEN	R/W	0	Stall QEI Value Description 0 The QEI module does not stall when the microcontroller is stopped by a debugger. 1 The QEI module stalls when the microcontroller is stopped by a debugger.

Bit/Field	Name	Type	Reset	Description
11	INVI	R/W	0	Invert Index Pulse Value Description 0 No effect. 1 Inverts the <code>IDX</code> input.
10	INVB	R/W	0	Invert PhB Value Description 0 No effect. 1 Inverts the <code>PhB</code> input.
9	INVA	R/W	0	Invert PhA Value Description 0 No effect. 1 Inverts the <code>PhA</code> input.
8:6	VELDIV	R/W	0x0	Predivide Velocity This field defines the predivider of the input quadrature pulses before being applied to the <code>QEICOUNT</code> accumulator. Value Predivider 0x0 ÷1 0x1 ÷2 0x2 ÷4 0x3 ÷8 0x4 ÷16 0x5 ÷32 0x6 ÷64 0x7 ÷128
5	VELEN	R/W	0	Capture Velocity Value Description 0 No effect. 1 Enables capture of the velocity of the quadrature encoder.
4	RESMODE	R/W	0	Reset Mode Value Description 0 The position counter is reset when it reaches the maximum as defined by the <code>MAXPOS</code> field in the <code>QEIMAXPOS</code> register. 1 The position counter is reset when the index pulse is captured.

Bit/Field	Name	Type	Reset	Description
3	CAPMODE	R/W	0	Capture Mode Value Description 0 Only the PhA edges are counted. 1 The PhA and PhB edges are counted, providing twice the positional resolution but half the range.
2	SIGMODE	R/W	0	Signal Mode Value Description 0 The PhA and PhB signals operate as quadrature phase signals. 1 The PhA and PhB signals operate as clock and direction.
1	SWAP	R/W	0	Swap Signals Value Description 0 No effect. 1 Swaps the PhA and PhB signals.
0	ENABLE	R/W	0	Enable QEI Value Description 0 No effect. 1 Enables the quadrature encoder module.

Register 2: QEI Status (QEISTAT), offset 0x004

This register provides status about the operation of the QEI module.

QEI Status (QEISTAT)

QEI0 base: 0x4002.C000

QEI1 base: 0x4002.D000

Offset 0x004

Type RO, reset 0x0000.0000

	31	30	29	28	27	26	25	24	23	22	21	20	19	18	17	16	
	reserved																
Type	RO	RO	RO	RO	RO	RO	RO	RO	RO	RO	RO	RO	RO	RO	RO	RO	
Reset	0	0	0	0	0	0	0	0	0	0	0	0	0	0	0	0	
	15	14	13	12	11	10	9	8	7	6	5	4	3	2	1	0	
	reserved															DIRECTION	ERROR
Type	RO	RO	RO	RO	RO	RO	RO	RO	RO	RO	RO	RO	RO	RO	RO	RO	RO
Reset	0	0	0	0	0	0	0	0	0	0	0	0	0	0	0	0	0

Bit/Field	Name	Type	Reset	Description
31:2	reserved	RO	0x0000.000	Software should not rely on the value of a reserved bit. To provide compatibility with future products, the value of a reserved bit should be preserved across a read-modify-write operation.
1	DIRECTION	RO	0	Direction of Rotation Indicates the direction the encoder is rotating. Value Description 0 The encoder is rotating forward. 1 The encoder is rotating in reverse.
0	ERROR	RO	0	Error Detected Value Description 0 No error. 1 An error was detected in the gray code sequence (that is, both signals changing at the same time).

Register 3: QEI Position (QEIP0S), offset 0x008

This register contains the current value of the position integrator. The value is updated by the status of the QEI phase inputs and can be set to a specific value by writing to it.

QEI Position (QEIP0S)

QEI0 base: 0x4002.C000

QEI1 base: 0x4002.D000

Offset 0x008

Type R/W, reset 0x0000.0000

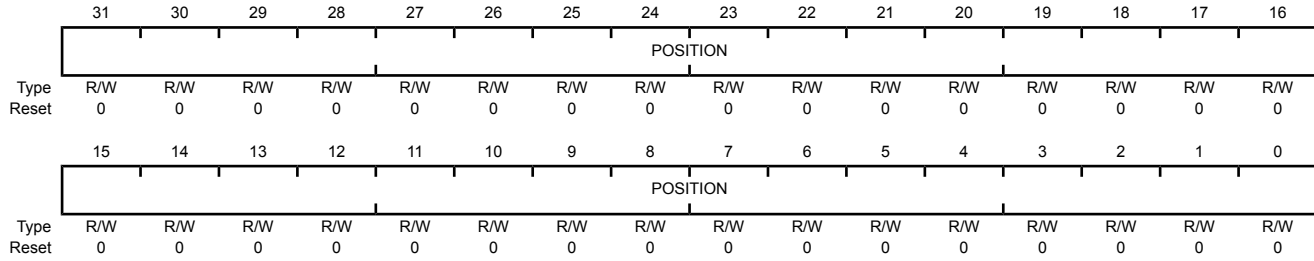

Bit/Field	Name	Type	Reset	Description
31:0	POSITION	R/W	0x0000.0000	Current Position Integrator Value The current value of the position integrator.

Register 4: QEI Maximum Position (QEIMAXPOS), offset 0x00C

This register contains the maximum value of the position integrator. When moving forward, the position register resets to zero when it increments past this value. When moving in reverse, the position register resets to this value when it decrements from zero.

QEI Maximum Position (QEIMAXPOS)

QEI0 base: 0x4002.C000

QEI1 base: 0x4002.D000

Offset 0x00C

Type R/W, reset 0x0000.0000

	31	30	29	28	27	26	25	24	23	22	21	20	19	18	17	16
	MAXPOS															
Type	R/W	R/W	R/W	R/W	R/W	R/W	R/W	R/W	R/W	R/W	R/W	R/W	R/W	R/W	R/W	R/W
Reset	0	0	0	0	0	0	0	0	0	0	0	0	0	0	0	0
	15	14	13	12	11	10	9	8	7	6	5	4	3	2	1	0
	MAXPOS															
Type	R/W	R/W	R/W	R/W	R/W	R/W	R/W	R/W	R/W	R/W	R/W	R/W	R/W	R/W	R/W	R/W
Reset	0	0	0	0	0	0	0	0	0	0	0	0	0	0	0	0

Bit/Field	Name	Type	Reset	Description
31:0	MAXPOS	R/W	0x0000.0000	Maximum Position Integrator Value The maximum value of the position integrator.

Register 5: QEI Timer Load (QEILOAD), offset 0x010

This register contains the load value for the velocity timer. Because this value is loaded into the timer on the clock cycle after the timer is zero, this value should be one less than the number of clocks in the desired period. So, for example, to have 2000 decimal clocks per timer period, this register should contain 1999 decimal.

QEI Timer Load (QEILOAD)

QEI0 base: 0x4002.C000
 QEI1 base: 0x4002.D000
 Offset 0x010
 Type R/W, reset 0x0000.0000

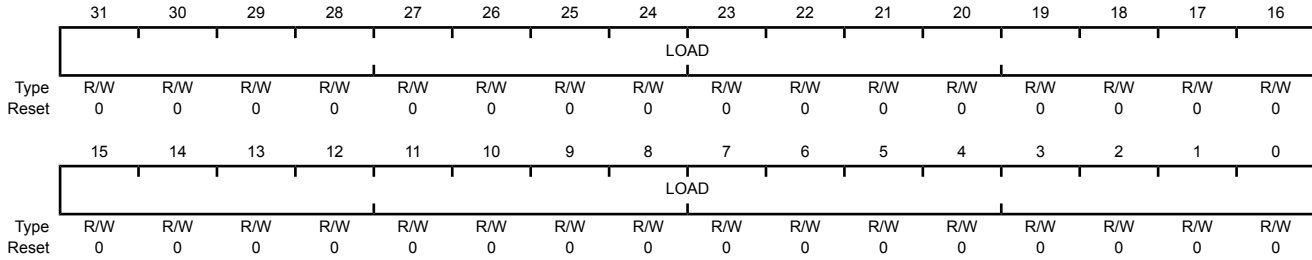

Bit/Field	Name	Type	Reset	Description
31:0	LOAD	R/W	0x0000.0000	Velocity Timer Load Value The load value for the velocity timer.

Register 6: QEI Timer (QEITIME), offset 0x014

This register contains the current value of the velocity timer. This counter does not increment when the `VELEN` bit in the `QEICTL` register is clear.

QEI Timer (QEITIME)

QEI0 base: 0x4002.C000

QEI1 base: 0x4002.D000

Offset 0x014

Type RO, reset 0x0000.0000

	31	30	29	28	27	26	25	24	23	22	21	20	19	18	17	16
	TIME															
Type	RO	RO	RO	RO	RO	RO	RO	RO	RO	RO	RO	RO	RO	RO	RO	RO
Reset	0	0	0	0	0	0	0	0	0	0	0	0	0	0	0	0
	15	14	13	12	11	10	9	8	7	6	5	4	3	2	1	0
	TIME															
Type	RO	RO	RO	RO	RO	RO	RO	RO	RO	RO	RO	RO	RO	RO	RO	RO
Reset	0	0	0	0	0	0	0	0	0	0	0	0	0	0	0	0

Bit/Field	Name	Type	Reset	Description
31:0	TIME	RO	0x0000.0000	Velocity Timer Current Value The current value of the velocity timer.

Register 7: QEI Velocity Counter (QEICOUNT), offset 0x018

This register contains the running count of velocity pulses for the current time period. Because this count is a running total, the time period to which it applies cannot be known with precision (that is, a read of this register does not necessarily correspond to the time returned by the **QEITIME** register because there is a small window of time between the two reads, during which either value may have changed). The **QEISPEED** register should be used to determine the actual encoder velocity; this register is provided for information purposes only. This counter does not increment when the **VELEN** bit in the **QEICTL** register is clear.

QEI Velocity Counter (QEICOUNT)

QEI0 base: 0x4002.C000
 QEI1 base: 0x4002.D000
 Offset 0x018
 Type RO, reset 0x0000.0000

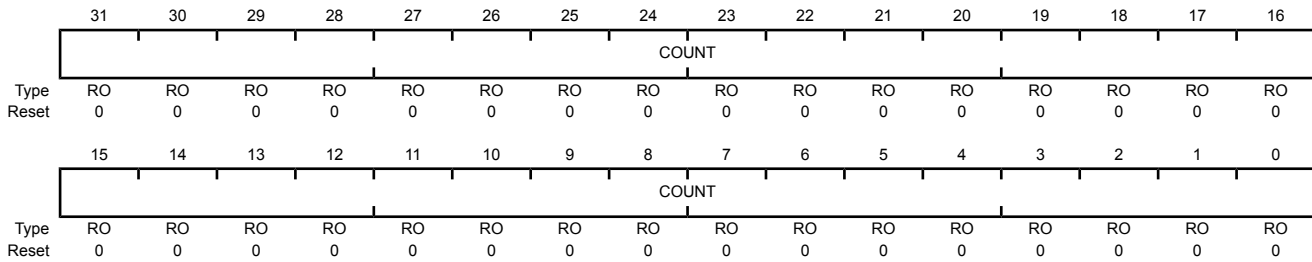

Bit/Field	Name	Type	Reset	Description
31:0	COUNT	RO	0x0000.0000	Velocity Pulse Count The running total of encoder pulses during this velocity timer period.

Register 8: QEI Velocity (QEISPEED), offset 0x01C

This register contains the most recently measured velocity of the quadrature encoder. This value corresponds to the number of velocity pulses counted in the previous velocity timer period. This register does not update when the `VELEN` bit in the `QEICTL` register is clear.

QEI Velocity (QEISPEED)

QEI0 base: 0x4002.C000

QEI1 base: 0x4002.D000

Offset 0x01C

Type RO, reset 0x0000.0000

	31	30	29	28	27	26	25	24	23	22	21	20	19	18	17	16
	SPEED															
Type	RO	RO	RO	RO	RO	RO	RO	RO	RO	RO	RO	RO	RO	RO	RO	RO
Reset	0	0	0	0	0	0	0	0	0	0	0	0	0	0	0	0
	15	14	13	12	11	10	9	8	7	6	5	4	3	2	1	0
	SPEED															
Type	RO	RO	RO	RO	RO	RO	RO	RO	RO	RO	RO	RO	RO	RO	RO	RO
Reset	0	0	0	0	0	0	0	0	0	0	0	0	0	0	0	0

Bit/Field	Name	Type	Reset	Description
31:0	SPEED	RO	0x0000.0000	Velocity The measured speed of the quadrature encoder in pulses per period.

Register 9: QEI Interrupt Enable (QEIINTEN), offset 0x020

This register contains enables for each of the QEI module interrupts. An interrupt is asserted to the interrupt controller if the corresponding bit in this register is set.

QEI Interrupt Enable (QEIINTEN)

QEI0 base: 0x4002.C000
 QEI1 base: 0x4002.D000
 Offset 0x020
 Type R/W, reset 0x0000.0000

	31	30	29	28	27	26	25	24	23	22	21	20	19	18	17	16	
	reserved																
Type	RO	RO	RO	RO	RO	RO	RO	RO	RO	RO	RO	RO	RO	RO	RO	RO	
Reset	0	0	0	0	0	0	0	0	0	0	0	0	0	0	0	0	
	15	14	13	12	11	10	9	8	7	6	5	4	3	2	1	0	
	reserved												INTERROR	INTDIR	INTTIMER	INTINDEX	
Type	RO	RO	RO	RO	RO	RO	RO	RO	RO	RO	RO	RO	RO	R/W	R/W	R/W	R/W
Reset	0	0	0	0	0	0	0	0	0	0	0	0	0	0	0	0	0

Bit/Field	Name	Type	Reset	Description
31:4	reserved	RO	0x0000.000	Software should not rely on the value of a reserved bit. To provide compatibility with future products, the value of a reserved bit should be preserved across a read-modify-write operation.
3	INTERROR	R/W	0	Phase Error Interrupt Enable Value Description 1 An interrupt is sent to the interrupt controller when the INTERROR bit in the QEIRIS register is set. 0 The INTERROR interrupt is suppressed and not sent to the interrupt controller.
2	INTDIR	R/W	0	Direction Change Interrupt Enable Value Description 1 An interrupt is sent to the interrupt controller when the INTDIR bit in the QEIRIS register is set. 0 The INTDIR interrupt is suppressed and not sent to the interrupt controller.
1	INTTIMER	R/W	0	Timer Expires Interrupt Enable Value Description 1 An interrupt is sent to the interrupt controller when the INTTIMER bit in the QEIRIS register is set. 0 The INTTIMER interrupt is suppressed and not sent to the interrupt controller.

Bit/Field	Name	Type	Reset	Description
0	INTINDEX	R/W	0	Index Pulse Detected Interrupt Enable
				Value Description
				1 An interrupt is sent to the interrupt controller when the INTINDEX bit in the QEIRIS register is set.
				0 The INTINDEX interrupt is suppressed and not sent to the interrupt controller.

Register 10: QEI Raw Interrupt Status (QEIRIS), offset 0x024

This register provides the current set of interrupt sources that are asserted, regardless of whether they cause an interrupt to be asserted to the controller (configured through the **QEIINTEN** register). If a bit is set, the latched event has occurred; if a bit is clear, the event in question has not occurred.

QEI Raw Interrupt Status (QEIRIS)

QEI0 base: 0x4002.C000
 QEI1 base: 0x4002.D000
 Offset 0x024
 Type RO, reset 0x0000.0000

	31	30	29	28	27	26	25	24	23	22	21	20	19	18	17	16
	reserved															
Type	RO	RO	RO	RO	RO	RO	RO	RO	RO	RO	RO	RO	RO	RO	RO	RO
Reset	0	0	0	0	0	0	0	0	0	0	0	0	0	0	0	0
	15	14	13	12	11	10	9	8	7	6	5	4	3	2	1	0
	reserved												INTERROR	INTDIR	INTTIMER	INTINDEX
Type	RO	RO	RO	RO	RO	RO	RO	RO	RO	RO	RO	RO	RO	RO	RO	RO
Reset	0	0	0	0	0	0	0	0	0	0	0	0	0	0	0	0

Bit/Field	Name	Type	Reset	Description
31:4	reserved	RO	0x0000.000	Software should not rely on the value of a reserved bit. To provide compatibility with future products, the value of a reserved bit should be preserved across a read-modify-write operation.
3	INTERROR	RO	0	Phase Error Detected Value Description 1 A phase error has been detected. 0 An interrupt has not occurred. This bit is cleared by writing a 1 to the <code>INTERROR</code> bit in the QEIISC register.
2	INTDIR	RO	0	Direction Change Detected Value Description 1 The rotation direction has changed 0 An interrupt has not occurred. This bit is cleared by writing a 1 to the <code>INTDIR</code> bit in the QEIISC register.
1	INTTIMER	RO	0	Velocity Timer Expired Value Description 1 The velocity timer has expired. 0 An interrupt has not occurred. This bit is cleared by writing a 1 to the <code>INTTIMER</code> bit in the QEIISC register.

Bit/Field	Name	Type	Reset	Description
0	INTINDEX	RO	0	Index Pulse Asserted
				Value Description
				1 The index pulse has occurred.
				0 An interrupt has not occurred.
				This bit is cleared by writing a 1 to the INTINDEX bit in the QEISC register.

Register 11: QEI Interrupt Status and Clear (QEIISC), offset 0x028

This register provides the current set of interrupt sources that are asserted to the controller. If a bit is set, the latched event has occurred and is enabled to generate an interrupt; if a bit is clear the event in question has not occurred or is not enabled to generate an interrupt. This register is R/W1C; writing a 1 to a bit position clears the bit and the corresponding interrupt reason.

QEI Interrupt Status and Clear (QEIISC)

QEI0 base: 0x4002.C000
 QEI1 base: 0x4002.D000
 Offset 0x028
 Type R/W1C, reset 0x0000.0000

	31	30	29	28	27	26	25	24	23	22	21	20	19	18	17	16	
	reserved																
Type	RO	RO	RO	RO	RO	RO	RO	RO	RO	RO	RO	RO	RO	RO	RO	RO	
Reset	0	0	0	0	0	0	0	0	0	0	0	0	0	0	0	0	
	15	14	13	12	11	10	9	8	7	6	5	4	3	2	1	0	
	reserved												INTERROR	INTDIR	INTTIMER	INTINDEX	
Type	RO	RO	RO	RO	RO	RO	RO	RO	RO	RO	RO	RO	RO	R/W1C	R/W1C	R/W1C	R/W1C
Reset	0	0	0	0	0	0	0	0	0	0	0	0	0	0	0	0	0

Bit/Field	Name	Type	Reset	Description
31:4	reserved	RO	0x0000.000	Software should not rely on the value of a reserved bit. To provide compatibility with future products, the value of a reserved bit should be preserved across a read-modify-write operation.
3	INTERROR	R/W1C	0	Phase Error Interrupt Value Description 1 The INTERROR bits in the QEIRIS register and the QEINTEN registers are set, providing an interrupt to the interrupt controller. 0 No interrupt has occurred or the interrupt is masked. This bit is cleared by writing a 1. Clearing this bit also clears the INTERROR bit in the QEIRIS register.
2	INTDIR	R/W1C	0	Direction Change Interrupt Value Description 1 The INTDIR bits in the QEIRIS register and the QEINTEN registers are set, providing an interrupt to the interrupt controller. 0 No interrupt has occurred or the interrupt is masked. This bit is cleared by writing a 1. Clearing this bit also clears the INTDIR bit in the QEIRIS register.
1	INTTIMER	R/W1C	0	Velocity Timer Expired Interrupt Value Description 1 The INTTIMER bits in the QEIRIS register and the QEINTEN registers are set, providing an interrupt to the interrupt controller. 0 No interrupt has occurred or the interrupt is masked. This bit is cleared by writing a 1. Clearing this bit also clears the INTTIMER bit in the QEIRIS register.

Bit/Field	Name	Type	Reset	Description
0	INTINDEX	R/W1C	0	Index Pulse Interrupt
				Value Description
				1 The INTINDEX bits in the QEIRIS register and the QEINTEN registers are set, providing an interrupt to the interrupt controller.
				0 No interrupt has occurred or the interrupt is masked.
				This bit is cleared by writing a 1. Clearing this bit also clears the INTINDEX bit in the QEIRIS register.

21 Pin Diagram

The LM4F231H5QR microcontroller pin diagram is shown below.

Each GPIO signal is identified by its GPIO port unless it defaults to an alternate function on reset. In this case, the GPIO port name is followed by the default alternate function. To see a complete list of possible functions for each pin, see Table 22-5 on page 1314.

Figure 21-1. 64-Pin LQFP Package Pin Diagram

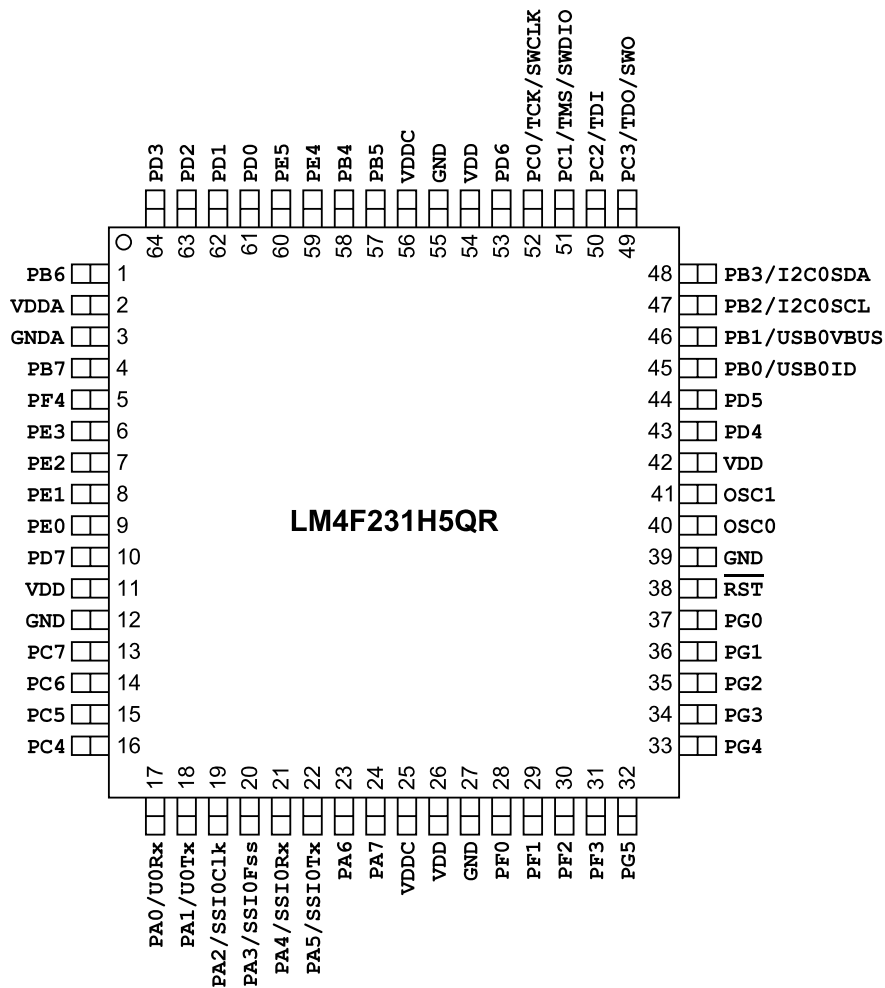

22 Signal Tables

The following tables list the signals available for each pin. Signals are configured as GPIOs on reset, except for those noted below. Use the **GPIOAMSEL** register (see page 660) to select analog mode. For a GPIO pin to be used for an alternate digital function, the corresponding bit in the **GPIOAFSEL** register (see page 644) must be set. Further pin muxing options are provided through the PMC_x bit field in the **GPIOPCTL** register (see page 661), which selects one of several available peripheral functions for that GPIO.

Important: All GPIO pins are configured as GPIOs by default with the exception of the pins shown in the table below. A Power-On-Reset (\overline{POR}) or asserting \overline{RST} puts the pins back to their default state.

Table 22-1. GPIO Pins With Default Alternate Functions

GPIO Pin	Default State	GPIOAFSEL Bit	GPIOPCTL PMC_x Bit Field
PA[1:0]	UART0	0	0x1
PA[5:2]	SSI0	0	0x1
PB[3:2]	I ² C0	0	0x1
PC[3:0]	JTAG/SWD	1	0x3

Table 22-2 on page 1292 shows the pin-to-signal-name mapping, including functional characteristics of the signals. Each possible alternate analog and digital function is listed for each pin.

Table 22-3 on page 1300 lists the signals in alphabetical order by signal name. If it is possible for a signal to be on multiple pins, each possible pin assignment is listed. The "Pin Mux" column indicates the GPIO and the encoding needed in the PMC_x bit field in the **GPIOPCTL** register.

Table 22-4 on page 1307 groups the signals by functionality, except for GPIOs. If it is possible for a signal to be on multiple pins, each possible pin assignment is listed.

Table 22-5 on page 1314 lists the GPIO pins and their analog and digital alternate functions. The A_{INx} analog signals are not 5-V tolerant and go through an isolation circuit before reaching their circuitry. These signals are configured by clearing the corresponding DEN bit in the **GPIO Digital Enable (GPIODEN)** register and setting the corresponding $AMSEL$ bit in the **GPIO Analog Mode Select (GPIOAMSEL)** register. Other analog signals are 5-V tolerant and are connected directly to their circuitry ($C0-$, $C0+$, $C1-$, $C1+$, $USB0VBUS$, $USB0ID$). These signals are configured by clearing the DEN bit in the **GPIO Digital Enable (GPIODEN)** register. The digital signals are enabled by setting the appropriate bit in the **GPIO Alternate Function Select (GPIOAFSEL)** and **GPIODEN** registers and configuring the PMC_x bit field in the **GPIO Port Control (GPIOPCTL)** register to the numeric encoding shown in the table below. Table entries that are shaded gray are the default values for the corresponding GPIO pin.

Table 22-6 on page 1316 lists the signals based on number of possible pin assignments. This table can be used to plan how to configure the pins for a particular functionality. Application Note AN01274 Configuring Stellaris® Microcontrollers with Pin Multiplexing provides an overview of the pin muxing implementation, an explanation of how a system designer defines a pin configuration, and examples of the pin configuration process.

Note: All digital inputs are Schmitt triggered.

Table 22-2. Signals by Pin Number

Pin Number	Pin Name	Pin Type	Buffer Type ^a	Description
1	PB6	I/O	TTL	GPIO port B bit 6.
	I2C5SCL	I/O	OD	I ² C module 5 clock. Note that this signal has an active pull-up. The corresponding port pin should not be configured as open drain.
	M0PWM0	O	TTL	Motion Control Module 0 PWM 0. This signal is controlled by Module 0 PWM Generator 0.
	SSI2Rx	I	TTL	SSI module 2 receive
	T0CCP0	I/O	TTL	16/32-Bit Timer 0 Capture/Compare/PWM 0.
2	VDDA	-	Power	The positive supply for the analog circuits (ADC, Analog Comparators, etc.). These are separated from VDD to minimize the electrical noise contained on VDD from affecting the analog functions. VDDA pins must be supplied with a voltage that meets the specification in Table 24-2 on page 1323, regardless of system implementation.
3	GND A	-	Power	The ground reference for the analog circuits (ADC, Analog Comparators, etc.). These are separated from GND to minimize the electrical noise contained on VDD from affecting the analog functions.
4	PB7	I/O	TTL	GPIO port B bit 7.
	I2C5SDA	I/O	OD	I ² C module 5 data.
	M0PWM1	O	TTL	Motion Control Module 0 PWM 1. This signal is controlled by Module 0 PWM Generator 0.
	SSI2Tx	O	TTL	SSI module 2 transmit
	T0CCP1	I/O	TTL	16/32-Bit Timer 0 Capture/Compare/PWM 1.
5	PF4	I/O	TTL	GPIO port F bit 4.
	IDX0	I	TTL	QEI module 0 index.
	M0FAULT2	I	TTL	Motion Control Module 0 PWM Fault 2.
	M1FAULT0	I	TTL	Motion Control Module 1 PWM Fault 0.
	T2CCP0	I/O	TTL	16/32-Bit Timer 2 Capture/Compare/PWM 0.
	USB0EPEN	O	TTL	Optionally used in Host mode to control an external power source to supply power to the USB bus.
6	PE3	I/O	TTL	GPIO port E bit 3.
	AIN0	I	Analog	Analog-to-digital converter input 0.
7	PE2	I/O	TTL	GPIO port E bit 2.
	AIN1	I	Analog	Analog-to-digital converter input 1.
8	PE1	I/O	TTL	GPIO port E bit 1.
	AIN2	I	Analog	Analog-to-digital converter input 2.
	U7Tx	O	TTL	UART module 7 transmit.
9	PE0	I/O	TTL	GPIO port E bit 0.
	AIN3	I	Analog	Analog-to-digital converter input 3.
	U7Rx	I	TTL	UART module 7 receive.

Table 22-2. Signals by Pin Number (continued)

Pin Number	Pin Name	Pin Type	Buffer Type ^a	Description
10	PD7	I/O	TTL	GPIO port D bit 7.
	M0FAULT1	I	TTL	Motion Control Module 0 PWM Fault 1.
	NMI	I	TTL	Non-maskable interrupt.
	PhB0	I	TTL	QEI module 0 phase B.
	U2Tx	O	TTL	UART module 2 transmit.
	WT5CCP1	I/O	TTL	32/64-Bit Wide Timer 5 Capture/Compare/PWM 1.
11	VDD	-	Power	Positive supply for I/O and some logic.
12	GND	-	Power	Ground reference for logic and I/O pins.
13	PC7	I/O	TTL	GPIO port C bit 7.
	C0-	I	Analog	Analog comparator 0 negative input.
	U3Tx	O	TTL	UART module 3 transmit.
	USB0PFLT	I	TTL	Optionally used in Host mode by an external power source to indicate an error state by that power source.
	WT1CCP1	I/O	TTL	32/64-Bit Wide Timer 1 Capture/Compare/PWM 1.
14	PC6	I/O	TTL	GPIO port C bit 6.
	C0+	I	Analog	Analog comparator 0 positive input.
	PhB1	I	TTL	QEI module 1 phase B.
	U3Rx	I	TTL	UART module 3 receive.
	USB0EPEN	O	TTL	Optionally used in Host mode to control an external power source to supply power to the USB bus.
	WT1CCP0	I/O	TTL	32/64-Bit Wide Timer 1 Capture/Compare/PWM 0.
15	PC5	I/O	TTL	GPIO port C bit 5.
	C1+	I	Analog	Analog comparator 1 positive input.
	M0PWM7	O	TTL	Motion Control Module 0 PWM 7. This signal is controlled by Module 0 PWM Generator 3.
	PhA1	I	TTL	QEI module 1 phase A.
	U1CTS	I	TTL	UART module 1 Clear To Send modem flow control input signal.
	U1Tx	O	TTL	UART module 1 transmit.
	U4Tx	O	TTL	UART module 4 transmit.
	WT0CCP1	I/O	TTL	32/64-Bit Wide Timer 0 Capture/Compare/PWM 1.
16	PC4	I/O	TTL	GPIO port C bit 4.
	C1-	I	Analog	Analog comparator 1 negative input.
	IDX1	I	TTL	QEI module 1 index.
	M0PWM6	O	TTL	Motion Control Module 0 PWM 6. This signal is controlled by Module 0 PWM Generator 3.
	U1RTS	O	TTL	UART module 1 Request to Send modem flow control output line.
	U1Rx	I	TTL	UART module 1 receive.
	U4Rx	I	TTL	UART module 4 receive.
	WT0CCP0	I/O	TTL	32/64-Bit Wide Timer 0 Capture/Compare/PWM 0.
17	PA0	I/O	TTL	GPIO port A bit 0.
	CAN1Rx	I	TTL	CAN module 1 receive.
	U0Rx	I	TTL	UART module 0 receive.

Table 22-2. Signals by Pin Number (continued)

Pin Number	Pin Name	Pin Type	Buffer Type ^a	Description
18	PA1	I/O	TTL	GPIO port A bit 1.
	CAN1Tx	O	TTL	CAN module 1 transmit.
	U0Tx	O	TTL	UART module 0 transmit.
19	PA2	I/O	TTL	GPIO port A bit 2.
	SSI0Clk	I/O	TTL	SSI module 0 clock
20	PA3	I/O	TTL	GPIO port A bit 3.
	SSI0Fss	I/O	TTL	SSI module 0 frame signal
21	PA4	I/O	TTL	GPIO port A bit 4.
	SSI0Rx	I	TTL	SSI module 0 receive
22	PA5	I/O	TTL	GPIO port A bit 5.
	SSI0Tx	O	TTL	SSI module 0 transmit
23	PA6	I/O	TTL	GPIO port A bit 6.
	I2C1SCL	I/O	OD	I ² C module 1 clock. Note that this signal has an active pull-up. The corresponding port pin should not be configured as open drain.
	M1PWM2	O	TTL	Motion Control Module 1 PWM 2. This signal is controlled by Module 1 PWM Generator 1.
24	PA7	I/O	TTL	GPIO port A bit 7.
	I2C1SDA	I/O	OD	I ² C module 1 data.
	M1PWM3	O	TTL	Motion Control Module 1 PWM 3. This signal is controlled by Module 1 PWM Generator 1.
25	VDDC	-	Power	Positive supply for most of the logic function, including the processor core and most peripherals. The voltage on this pin is 1.2 V and is supplied by the on-chip LDO. The VDDC pins should only be connected to each other and an external capacitor as specified in Table 24-8 on page 1328 .
26	VDD	-	Power	Positive supply for I/O and some logic.
27	GND	-	Power	Ground reference for logic and I/O pins.
28	PF0	I/O	TTL	GPIO port F bit 0.
	C0o	O	TTL	Analog comparator 0 output.
	CAN0Rx	I	TTL	CAN module 0 receive.
	M1PWM4	O	TTL	Motion Control Module 1 PWM 4. This signal is controlled by Module 1 PWM Generator 2.
	NMI	I	TTL	Non-maskable interrupt.
	PhA0	I	TTL	QEI module 0 phase A.
	SSI1Rx	I	TTL	SSI module 1 receive
	T0CCP0	I/O	TTL	16/32-Bit Timer 0 Capture/Compare/PWM 0.
	U1RTS	O	TTL	UART module 1 Request to Send modem flow control output line.

Table 22-2. Signals by Pin Number (continued)

Pin Number	Pin Name	Pin Type	Buffer Type ^a	Description
29	PF1	I/O	TTL	GPIO port F bit 1.
	C1o	O	TTL	Analog comparator 1 output.
	M1PWM5	O	TTL	Motion Control Module 1 PWM 5. This signal is controlled by Module 1 PWM Generator 2.
	PhB0	I	TTL	QEI module 0 phase B.
	SSI1Tx	O	TTL	SSI module 1 transmit
	T0CCP1	I/O	TTL	16/32-Bit Timer 0 Capture/Compare/PWM 1.
	TRD1	O	TTL	Trace data 1.
30	U1CTS	I	TTL	UART module 1 Clear To Send modem flow control input signal.
	PF2	I/O	TTL	GPIO port F bit 2.
	M0FAULT0	I	TTL	Motion Control Module 0 PWM Fault 0.
	M1PWM6	O	TTL	Motion Control Module 1 PWM 6. This signal is controlled by Module 1 PWM Generator 3.
	SSI1Clk	I/O	TTL	SSI module 1 clock
	T1CCP0	I/O	TTL	16/32-Bit Timer 1 Capture/Compare/PWM 0.
31	TRD0	O	TTL	Trace data 0.
	PF3	I/O	TTL	GPIO port F bit 3.
	CAN0Tx	O	TTL	CAN module 0 transmit.
	M0FAULT1	I	TTL	Motion Control Module 0 PWM Fault 1.
	M1PWM7	O	TTL	Motion Control Module 1 PWM 7. This signal is controlled by Module 1 PWM Generator 3.
	SSI1Fss	I/O	TTL	SSI module 1 frame signal
	T1CCP1	I/O	TTL	16/32-Bit Timer 1 Capture/Compare/PWM 1.
32	TRCLK	O	TTL	Trace clock.
	PG5	I/O	TTL	GPIO port G bit 5.
	I2C1SDA	I/O	OD	I ² C module 1 data.
	IDX1	I	TTL	QEI module 1 index.
	M0PWM5	O	TTL	Motion Control Module 0 PWM 5. This signal is controlled by Module 0 PWM Generator 2.
	M1PWM3	O	TTL	Motion Control Module 1 PWM 3. This signal is controlled by Module 1 PWM Generator 1.
	U2Tx	O	TTL	UART module 2 transmit.
32	USB0PFLT	I	TTL	Optionally used in Host mode by an external power source to indicate an error state by that power source.
	WT0CCP1	I/O	TTL	32/64-Bit Wide Timer 0 Capture/Compare/PWM 1.

Table 22-2. Signals by Pin Number (continued)

Pin Number	Pin Name	Pin Type	Buffer Type ^a	Description
33	PG4	I/O	TTL	GPIO port G bit 4.
	I2C1SCL	I/O	OD	I ² C module 1 clock. Note that this signal has an active pull-up. The corresponding port pin should not be configured as open drain.
	M0PWM4	O	TTL	Motion Control Module 0 PWM 4. This signal is controlled by Module 0 PWM Generator 2.
	M1PWM2	O	TTL	Motion Control Module 1 PWM 2. This signal is controlled by Module 1 PWM Generator 1.
	PhB1	I	TTL	QEI module 1 phase B.
	U2Rx	I	TTL	UART module 2 receive.
	USB0EPEN	O	TTL	Optionally used in Host mode to control an external power source to supply power to the USB bus.
	WT0CCP0	I/O	TTL	32/64-Bit Wide Timer 0 Capture/Compare/PWM 0.
34	PG3	I/O	TTL	GPIO port G bit 3.
	I2C4SDA	I/O	OD	I ² C module 4 data.
	M0FAULT2	I	TTL	Motion Control Module 0 PWM Fault 2.
	M1PWM1	O	TTL	Motion Control Module 1 PWM 1. This signal is controlled by Module 1 PWM Generator 0.
	PhA1	I	TTL	QEI module 1 phase A.
	T5CCP1	I/O	TTL	16/32-Bit Timer 5 Capture/Compare/PWM 1.
35	PG2	I/O	TTL	GPIO port G bit 2.
	I2C4SCL	I/O	OD	I ² C module 4 clock. Note that this signal has an active pull-up. The corresponding port pin should not be configured as open drain.
	M0FAULT1	I	TTL	Motion Control Module 0 PWM Fault 1.
	M1PWM0	O	TTL	Motion Control Module 1 PWM 0. This signal is controlled by Module 1 PWM Generator 0.
	T5CCP0	I/O	TTL	16/32-Bit Timer 5 Capture/Compare/PWM 0.
36	PG1	I/O	TTL	GPIO port G bit 1.
	I2C3SDA	I/O	OD	I ² C module 3 data.
	M1FAULT2	I	TTL	Motion Control Module 1 PWM Fault 2.
	PhB1	I	TTL	QEI module 1 phase B.
	T4CCP1	I/O	TTL	16/32-Bit Timer 4 Capture/Compare/PWM 1.
37	PG0	I/O	TTL	GPIO port G bit 0.
	I2C3SCL	I/O	OD	I ² C module 3 clock. Note that this signal has an active pull-up. The corresponding port pin should not be configured as open drain.
	M1FAULT1	I	TTL	Motion Control Module 1 PWM Fault 1.
	PhA1	I	TTL	QEI module 1 phase A.
	T4CCP0	I/O	TTL	16/32-Bit Timer 4 Capture/Compare/PWM 0.
38	RST	I	TTL	System reset input.
39	GND	-	Power	Ground reference for logic and I/O pins.
40	OSC0	I	Analog	Main oscillator crystal input or an external clock reference input.
41	OSC1	O	Analog	Main oscillator crystal output. Leave unconnected when using a single-ended clock source.
42	VDD	-	Power	Positive supply for I/O and some logic.

Table 22-2. Signals by Pin Number (continued)

Pin Number	Pin Name	Pin Type	Buffer Type ^a	Description
43	PD4	I/O	TTL	GPIO port D bit 4.
	U6Rx	I	TTL	UART module 6 receive.
	USB0DM	I/O	Analog	Bidirectional differential data pin (D- per USB specification) for USB0.
	WT4CCP0	I/O	TTL	32/64-Bit Wide Timer 4 Capture/Compare/PWM 0.
44	PD5	I/O	TTL	GPIO port D bit 5.
	U6Tx	O	TTL	UART module 6 transmit.
	USB0DP	I/O	Analog	Bidirectional differential data pin (D+ per USB specification) for USB0.
	WT4CCP1	I/O	TTL	32/64-Bit Wide Timer 4 Capture/Compare/PWM 1.
45	PB0	I/O	TTL	GPIO port B bit 0. This pin is not 5-V tolerant.
	T2CCP0	I/O	TTL	16/32-Bit Timer 2 Capture/Compare/PWM 0.
	U1Rx	I	TTL	UART module 1 receive.
	USB0ID	I	Analog	This signal senses the state of the USB ID signal. The USB PHY enables an integrated pull-up, and an external element (USB connector) indicates the initial state of the USB controller (pulled down is the A side of the cable and pulled up is the B side).
46	PB1	I/O	TTL	GPIO port B bit 1. This pin is not 5-V tolerant.
	T2CCP1	I/O	TTL	16/32-Bit Timer 2 Capture/Compare/PWM 1.
	U1Tx	O	TTL	UART module 1 transmit.
	USB0VBUS	I/O	Analog	This signal is used during the session request protocol. This signal allows the USB PHY to both sense the voltage level of VBUS, and pull up VBUS momentarily during VBUS pulsing.
47	PB2	I/O	TTL	GPIO port B bit 2.
	I2C0SCL	I/O	OD	I ² C module 0 clock. Note that this signal has an active pull-up. The corresponding port pin should not be configured as open drain.
	T3CCP0	I/O	TTL	16/32-Bit Timer 3 Capture/Compare/PWM 0.
48	PB3	I/O	TTL	GPIO port B bit 3.
	I2C0SDA	I/O	OD	I ² C module 0 data.
	T3CCP1	I/O	TTL	16/32-Bit Timer 3 Capture/Compare/PWM 1.
49	PC3	I/O	TTL	GPIO port C bit 3.
	SWO	O	TTL	JTAG TDO and SWO.
	T5CCP1	I/O	TTL	16/32-Bit Timer 5 Capture/Compare/PWM 1.
	TDO	O	TTL	JTAG TDO and SWO.
50	PC2	I/O	TTL	GPIO port C bit 2.
	T5CCP0	I/O	TTL	16/32-Bit Timer 5 Capture/Compare/PWM 0.
	TDI	I	TTL	JTAG TDI.
51	PC1	I/O	TTL	GPIO port C bit 1.
	SWDIO	I/O	TTL	JTAG TMS and SWDIO.
	T4CCP1	I/O	TTL	16/32-Bit Timer 4 Capture/Compare/PWM 1.
	TMS	I	TTL	JTAG TMS and SWDIO.

Table 22-2. Signals by Pin Number (continued)

Pin Number	Pin Name	Pin Type	Buffer Type ^a	Description
52	PC0	I/O	TTL	GPIO port C bit 0.
	SWCLK	I	TTL	JTAG/SWD CLK.
	T4CCP0	I/O	TTL	16/32-Bit Timer 4 Capture/Compare/PWM 0.
	TCK	I	TTL	JTAG/SWD CLK.
53	PD6	I/O	TTL	GPIO port D bit 6.
	M0FAULT0	I	TTL	Motion Control Module 0 PWM Fault 0.
	PhA0	I	TTL	QEI module 0 phase A.
	U2Rx	I	TTL	UART module 2 receive.
	WT5CCP0	I/O	TTL	32/64-Bit Wide Timer 5 Capture/Compare/PWM 0.
54	VDD	-	Power	Positive supply for I/O and some logic.
55	GND	-	Power	Ground reference for logic and I/O pins.
56	VDDC	-	Power	Positive supply for most of the logic function, including the processor core and most peripherals. The voltage on this pin is 1.2 V and is supplied by the on-chip LDO. The VDDC pins should only be connected to each other and an external capacitor as specified in Table 24-8 on page 1328 .
57	PB5	I/O	TTL	GPIO port B bit 5.
	AIN11	I	Analog	Analog-to-digital converter input 11.
	CAN0Tx	O	TTL	CAN module 0 transmit.
	M0PWM3	O	TTL	Motion Control Module 0 PWM 3. This signal is controlled by Module 0 PWM Generator 1.
	SSI2Fss	I/O	TTL	SSI module 2 frame signal
	T1CCP1	I/O	TTL	16/32-Bit Timer 1 Capture/Compare/PWM 1.
58	PB4	I/O	TTL	GPIO port B bit 4.
	AIN10	I	Analog	Analog-to-digital converter input 10.
	CAN0Rx	I	TTL	CAN module 0 receive.
	M0PWM2	O	TTL	Motion Control Module 0 PWM 2. This signal is controlled by Module 0 PWM Generator 1.
	SSI2Clk	I/O	TTL	SSI module 2 clock
	T1CCP0	I/O	TTL	16/32-Bit Timer 1 Capture/Compare/PWM 0.
59	PE4	I/O	TTL	GPIO port E bit 4.
	AIN9	I	Analog	Analog-to-digital converter input 9.
	CAN0Rx	I	TTL	CAN module 0 receive.
	I2C2SCL	I/O	OD	I ² C module 2 clock. Note that this signal has an active pull-up. The corresponding port pin should not be configured as open drain.
	M0PWM4	O	TTL	Motion Control Module 0 PWM 4. This signal is controlled by Module 0 PWM Generator 2.
	M1PWM2	O	TTL	Motion Control Module 1 PWM 2. This signal is controlled by Module 1 PWM Generator 1.
	U5Rx	I	TTL	UART module 5 receive.

Table 22-2. Signals by Pin Number (continued)

Pin Number	Pin Name	Pin Type	Buffer Type ^a	Description
60	PE5	I/O	TTL	GPIO port E bit 5.
	AIN8	I	Analog	Analog-to-digital converter input 8.
	CAN0Tx	O	TTL	CAN module 0 transmit.
	I2C2SDA	I/O	OD	I ² C module 2 data.
	M0PWM5	O	TTL	Motion Control Module 0 PWM 5. This signal is controlled by Module 0 PWM Generator 2.
	M1PWM3	O	TTL	Motion Control Module 1 PWM 3. This signal is controlled by Module 1 PWM Generator 1.
	U5Tx	O	TTL	UART module 5 transmit.
61	PD0	I/O	TTL	GPIO port D bit 0.
	AIN7	I	Analog	Analog-to-digital converter input 7.
	I2C3SCL	I/O	OD	I ² C module 3 clock. Note that this signal has an active pull-up. The corresponding port pin should not be configured as open drain.
	M0PWM6	O	TTL	Motion Control Module 0 PWM 6. This signal is controlled by Module 0 PWM Generator 3.
	M1PWM0	O	TTL	Motion Control Module 1 PWM 0. This signal is controlled by Module 1 PWM Generator 0.
	SSI1C1k	I/O	TTL	SSI module 1 clock
	SSI3C1k	I/O	TTL	SSI module 3 clock
	WT2CCP0	I/O	TTL	32/64-Bit Wide Timer 2 Capture/Compare/PWM 0.
62	PD1	I/O	TTL	GPIO port D bit 1.
	AIN6	I	Analog	Analog-to-digital converter input 6.
	I2C3SDA	I/O	OD	I ² C module 3 data.
	M0PWM7	O	TTL	Motion Control Module 0 PWM 7. This signal is controlled by Module 0 PWM Generator 3.
	M1PWM1	O	TTL	Motion Control Module 1 PWM 1. This signal is controlled by Module 1 PWM Generator 0.
	SSI1Fss	I/O	TTL	SSI module 1 frame signal
	SSI3Fss	I/O	TTL	SSI module 3 frame signal
	WT2CCP1	I/O	TTL	32/64-Bit Wide Timer 2 Capture/Compare/PWM 1.
63	PD2	I/O	TTL	GPIO port D bit 2.
	AIN5	I	Analog	Analog-to-digital converter input 5.
	M0FAULT0	I	TTL	Motion Control Module 0 PWM Fault 0.
	SSI1Rx	I	TTL	SSI module 1 receive
	SSI3Rx	I	TTL	SSI module 3 receive
	USB0EPEN	O	TTL	Optionally used in Host mode to control an external power source to supply power to the USB bus.
	WT3CCP0	I/O	TTL	32/64-Bit Wide Timer 3 Capture/Compare/PWM 0.

Table 22-2. Signals by Pin Number (continued)

Pin Number	Pin Name	Pin Type	Buffer Type ^a	Description
64	PD3	I/O	TTL	GPIO port D bit 3.
	AIN4	I	Analog	Analog-to-digital converter input 4.
	IDX0	I	TTL	QEI module 0 index.
	SSI1Tx	O	TTL	SSI module 1 transmit
	SSI3Tx	O	TTL	SSI module 3 transmit
	USB0PFLT	I	TTL	Optionally used in Host mode by an external power source to indicate an error state by that power source.
	WT3CCP1	I/O	TTL	32/64-Bit Wide Timer 3 Capture/Compare/PWM 1.

a. The TTL designation indicates the pin has TTL-compatible voltage levels.

Table 22-3. Signals by Signal Name

Pin Name	Pin Number	Pin Mux / Pin Assignment	Pin Type	Buffer Type ^a	Description
AIN0	6	PE3	I	Analog	Analog-to-digital converter input 0.
AIN1	7	PE2	I	Analog	Analog-to-digital converter input 1.
AIN2	8	PE1	I	Analog	Analog-to-digital converter input 2.
AIN3	9	PE0	I	Analog	Analog-to-digital converter input 3.
AIN4	64	PD3	I	Analog	Analog-to-digital converter input 4.
AIN5	63	PD2	I	Analog	Analog-to-digital converter input 5.
AIN6	62	PD1	I	Analog	Analog-to-digital converter input 6.
AIN7	61	PD0	I	Analog	Analog-to-digital converter input 7.
AIN8	60	PE5	I	Analog	Analog-to-digital converter input 8.
AIN9	59	PE4	I	Analog	Analog-to-digital converter input 9.
AIN10	58	PB4	I	Analog	Analog-to-digital converter input 10.
AIN11	57	PB5	I	Analog	Analog-to-digital converter input 11.
C0+	14	PC6	I	Analog	Analog comparator 0 positive input.
C0-	13	PC7	I	Analog	Analog comparator 0 negative input.
C0o	28	PF0 (9)	O	TTL	Analog comparator 0 output.
C1+	15	PC5	I	Analog	Analog comparator 1 positive input.
C1-	16	PC4	I	Analog	Analog comparator 1 negative input.
C1o	29	PF1 (9)	O	TTL	Analog comparator 1 output.
CAN0Rx	28 58 59	PF0 (3) PB4 (8) PE4 (8)	I	TTL	CAN module 0 receive.
CAN0Tx	31 57 60	PF3 (3) PB5 (8) PE5 (8)	O	TTL	CAN module 0 transmit.
CAN1Rx	17	PA0 (8)	I	TTL	CAN module 1 receive.
CAN1Tx	18	PA1 (8)	O	TTL	CAN module 1 transmit.
GND	12 27 39 55	fixed	-	Power	Ground reference for logic and I/O pins.

Table 22-3. Signals by Signal Name (continued)

Pin Name	Pin Number	Pin Mux / Pin Assignment	Pin Type	Buffer Type ^a	Description
GND_A	3	fixed	-	Power	The ground reference for the analog circuits (ADC, Analog Comparators, etc.). These are separated from GND to minimize the electrical noise contained on VDD from affecting the analog functions.
I2C0SCL	47	PB2 (3)	I/O	OD	I ² C module 0 clock. Note that this signal has an active pull-up. The corresponding port pin should not be configured as open drain.
I2C0SDA	48	PB3 (3)	I/O	OD	I ² C module 0 data.
I2C1SCL	23 33	PA6 (3) PG4 (3)	I/O	OD	I ² C module 1 clock. Note that this signal has an active pull-up. The corresponding port pin should not be configured as open drain.
I2C1SDA	24 32	PA7 (3) PG5 (3)	I/O	OD	I ² C module 1 data.
I2C2SCL	59	PE4 (3)	I/O	OD	I ² C module 2 clock. Note that this signal has an active pull-up. The corresponding port pin should not be configured as open drain.
I2C2SDA	60	PE5 (3)	I/O	OD	I ² C module 2 data.
I2C3SCL	37 61	PG0 (3) PD0 (3)	I/O	OD	I ² C module 3 clock. Note that this signal has an active pull-up. The corresponding port pin should not be configured as open drain.
I2C3SDA	36 62	PG1 (3) PD1 (3)	I/O	OD	I ² C module 3 data.
I2C4SCL	35	PG2 (3)	I/O	OD	I ² C module 4 clock. Note that this signal has an active pull-up. The corresponding port pin should not be configured as open drain.
I2C4SDA	34	PG3 (3)	I/O	OD	I ² C module 4 data.
I2C5SCL	1	PB6 (3)	I/O	OD	I ² C module 5 clock. Note that this signal has an active pull-up. The corresponding port pin should not be configured as open drain.
I2C5SDA	4	PB7 (3)	I/O	OD	I ² C module 5 data.
IDX0	5 64	PF4 (6) PD3 (6)	I	TTL	QE1 module 0 index.
IDX1	16 32	PC4 (6) PG5 (6)	I	TTL	QE1 module 1 index.
M0FAULT0	30 53 63	PF2 (4) PD6 (4) PD2 (4)	I	TTL	Motion Control Module 0 PWM Fault 0.
M0FAULT1	10 31 35	PD7 (4) PF3 (4) PG2 (4)	I	TTL	Motion Control Module 0 PWM Fault 1.
M0FAULT2	5 34	PF4 (4) PG3 (4)	I	TTL	Motion Control Module 0 PWM Fault 2.
M0PWM0	1	PB6 (4)	O	TTL	Motion Control Module 0 PWM 0. This signal is controlled by Module 0 PWM Generator 0.
M0PWM1	4	PB7 (4)	O	TTL	Motion Control Module 0 PWM 1. This signal is controlled by Module 0 PWM Generator 0.
M0PWM2	58	PB4 (4)	O	TTL	Motion Control Module 0 PWM 2. This signal is controlled by Module 0 PWM Generator 1.

Table 22-3. Signals by Signal Name (continued)

Pin Name	Pin Number	Pin Mux / Pin Assignment	Pin Type	Buffer Type ^a	Description
M0PWM3	57	PB5 (4)	O	TTL	Motion Control Module 0 PWM 3. This signal is controlled by Module 0 PWM Generator 1.
M0PWM4	33 59	PG4 (4) PE4 (4)	O	TTL	Motion Control Module 0 PWM 4. This signal is controlled by Module 0 PWM Generator 2.
M0PWM5	32 60	PG5 (4) PE5 (4)	O	TTL	Motion Control Module 0 PWM 5. This signal is controlled by Module 0 PWM Generator 2.
M0PWM6	16 61	PC4 (4) PD0 (4)	O	TTL	Motion Control Module 0 PWM 6. This signal is controlled by Module 0 PWM Generator 3.
M0PWM7	15 62	PC5 (4) PD1 (4)	O	TTL	Motion Control Module 0 PWM 7. This signal is controlled by Module 0 PWM Generator 3.
M1FAULT0	5	PF4 (5)	I	TTL	Motion Control Module 1 PWM Fault 0.
M1FAULT1	37	PG0 (5)	I	TTL	Motion Control Module 1 PWM Fault 1.
M1FAULT2	36	PG1 (5)	I	TTL	Motion Control Module 1 PWM Fault 2.
M1PWM0	35 61	PG2 (5) PD0 (5)	O	TTL	Motion Control Module 1 PWM 0. This signal is controlled by Module 1 PWM Generator 0.
M1PWM1	34 62	PG3 (5) PD1 (5)	O	TTL	Motion Control Module 1 PWM 1. This signal is controlled by Module 1 PWM Generator 0.
M1PWM2	23 33 59	PA6 (5) PG4 (5) PE4 (5)	O	TTL	Motion Control Module 1 PWM 2. This signal is controlled by Module 1 PWM Generator 1.
M1PWM3	24 32 60	PA7 (5) PG5 (5) PE5 (5)	O	TTL	Motion Control Module 1 PWM 3. This signal is controlled by Module 1 PWM Generator 1.
M1PWM4	28	PF0 (5)	O	TTL	Motion Control Module 1 PWM 4. This signal is controlled by Module 1 PWM Generator 2.
M1PWM5	29	PF1 (5)	O	TTL	Motion Control Module 1 PWM 5. This signal is controlled by Module 1 PWM Generator 2.
M1PWM6	30	PF2 (5)	O	TTL	Motion Control Module 1 PWM 6. This signal is controlled by Module 1 PWM Generator 3.
M1PWM7	31	PF3 (5)	O	TTL	Motion Control Module 1 PWM 7. This signal is controlled by Module 1 PWM Generator 3.
NMI	10 28	PD7 (8) PF0 (8)	I	TTL	Non-maskable interrupt.
OSC0	40	fixed	I	Analog	Main oscillator crystal input or an external clock reference input.
OSC1	41	fixed	O	Analog	Main oscillator crystal output. Leave unconnected when using a single-ended clock source.
PA0	17	-	I/O	TTL	GPIO port A bit 0.
PA1	18	-	I/O	TTL	GPIO port A bit 1.
PA2	19	-	I/O	TTL	GPIO port A bit 2.
PA3	20	-	I/O	TTL	GPIO port A bit 3.
PA4	21	-	I/O	TTL	GPIO port A bit 4.
PA5	22	-	I/O	TTL	GPIO port A bit 5.
PA6	23	-	I/O	TTL	GPIO port A bit 6.
PA7	24	-	I/O	TTL	GPIO port A bit 7.
PB0	45	-	I/O	TTL	GPIO port B bit 0. This pin is not 5-V tolerant.

Table 22-3. Signals by Signal Name (continued)

Pin Name	Pin Number	Pin Mux / Pin Assignment	Pin Type	Buffer Type ^a	Description
PB1	46	-	I/O	TTL	GPIO port B bit 1. This pin is not 5-V tolerant.
PB2	47	-	I/O	TTL	GPIO port B bit 2.
PB3	48	-	I/O	TTL	GPIO port B bit 3.
PB4	58	-	I/O	TTL	GPIO port B bit 4.
PB5	57	-	I/O	TTL	GPIO port B bit 5.
PB6	1	-	I/O	TTL	GPIO port B bit 6.
PB7	4	-	I/O	TTL	GPIO port B bit 7.
PC0	52	-	I/O	TTL	GPIO port C bit 0.
PC1	51	-	I/O	TTL	GPIO port C bit 1.
PC2	50	-	I/O	TTL	GPIO port C bit 2.
PC3	49	-	I/O	TTL	GPIO port C bit 3.
PC4	16	-	I/O	TTL	GPIO port C bit 4.
PC5	15	-	I/O	TTL	GPIO port C bit 5.
PC6	14	-	I/O	TTL	GPIO port C bit 6.
PC7	13	-	I/O	TTL	GPIO port C bit 7.
PD0	61	-	I/O	TTL	GPIO port D bit 0.
PD1	62	-	I/O	TTL	GPIO port D bit 1.
PD2	63	-	I/O	TTL	GPIO port D bit 2.
PD3	64	-	I/O	TTL	GPIO port D bit 3.
PD4	43	-	I/O	TTL	GPIO port D bit 4.
PD5	44	-	I/O	TTL	GPIO port D bit 5.
PD6	53	-	I/O	TTL	GPIO port D bit 6.
PD7	10	-	I/O	TTL	GPIO port D bit 7.
PE0	9	-	I/O	TTL	GPIO port E bit 0.
PE1	8	-	I/O	TTL	GPIO port E bit 1.
PE2	7	-	I/O	TTL	GPIO port E bit 2.
PE3	6	-	I/O	TTL	GPIO port E bit 3.
PE4	59	-	I/O	TTL	GPIO port E bit 4.
PE5	60	-	I/O	TTL	GPIO port E bit 5.
PF0	28	-	I/O	TTL	GPIO port F bit 0.
PF1	29	-	I/O	TTL	GPIO port F bit 1.
PF2	30	-	I/O	TTL	GPIO port F bit 2.
PF3	31	-	I/O	TTL	GPIO port F bit 3.
PF4	5	-	I/O	TTL	GPIO port F bit 4.
PG0	37	-	I/O	TTL	GPIO port G bit 0.
PG1	36	-	I/O	TTL	GPIO port G bit 1.
PG2	35	-	I/O	TTL	GPIO port G bit 2.
PG3	34	-	I/O	TTL	GPIO port G bit 3.
PG4	33	-	I/O	TTL	GPIO port G bit 4.
PG5	32	-	I/O	TTL	GPIO port G bit 5.

Table 22-3. Signals by Signal Name (continued)

Pin Name	Pin Number	Pin Mux / Pin Assignment	Pin Type	Buffer Type ^a	Description
PhA0	28 53	PF0 (6) PD6 (6)	I	TTL	QE1 module 0 phase A.
PhA1	15 34 37	PC5 (6) PG3 (6) PG0 (6)	I	TTL	QE1 module 1 phase A.
PhB0	10 29	PD7 (6) PF1 (6)	I	TTL	QE1 module 0 phase B.
PhB1	14 33 36	PC6 (6) PG4 (6) PG1 (6)	I	TTL	QE1 module 1 phase B.
$\overline{\text{RST}}$	38	fixed	I	TTL	System reset input.
SSI0Clk	19	PA2 (2)	I/O	TTL	SSI module 0 clock
SSI0Fss	20	PA3 (2)	I/O	TTL	SSI module 0 frame signal
SSI0Rx	21	PA4 (2)	I	TTL	SSI module 0 receive
SSI0Tx	22	PA5 (2)	O	TTL	SSI module 0 transmit
SSI1Clk	30 61	PF2 (2) PD0 (2)	I/O	TTL	SSI module 1 clock
SSI1Fss	31 62	PF3 (2) PD1 (2)	I/O	TTL	SSI module 1 frame signal
SSI1Rx	28 63	PF0 (2) PD2 (2)	I	TTL	SSI module 1 receive
SSI1Tx	29 64	PF1 (2) PD3 (2)	O	TTL	SSI module 1 transmit
SSI2Clk	58	PB4 (2)	I/O	TTL	SSI module 2 clock
SSI2Fss	57	PB5 (2)	I/O	TTL	SSI module 2 frame signal
SSI2Rx	1	PB6 (2)	I	TTL	SSI module 2 receive
SSI2Tx	4	PB7 (2)	O	TTL	SSI module 2 transmit
SSI3Clk	61	PD0 (1)	I/O	TTL	SSI module 3 clock
SSI3Fss	62	PD1 (1)	I/O	TTL	SSI module 3 frame signal
SSI3Rx	63	PD2 (1)	I	TTL	SSI module 3 receive
SSI3Tx	64	PD3 (1)	O	TTL	SSI module 3 transmit
SWCLK	52	PC0 (1)	I	TTL	JTAG/SWD CLK.
SWDIO	51	PC1 (1)	I/O	TTL	JTAG TMS and SWDIO.
SWO	49	PC3 (1)	O	TTL	JTAG TDO and SWO.
T0CCP0	1 28	PB6 (7) PF0 (7)	I/O	TTL	16/32-Bit Timer 0 Capture/Compare/PWM 0.
T0CCP1	4 29	PB7 (7) PF1 (7)	I/O	TTL	16/32-Bit Timer 0 Capture/Compare/PWM 1.
T1CCP0	30 58	PF2 (7) PB4 (7)	I/O	TTL	16/32-Bit Timer 1 Capture/Compare/PWM 0.
T1CCP1	31 57	PF3 (7) PB5 (7)	I/O	TTL	16/32-Bit Timer 1 Capture/Compare/PWM 1.
T2CCP0	5 45	PF4 (7) PB0 (7)	I/O	TTL	16/32-Bit Timer 2 Capture/Compare/PWM 0.
T2CCP1	46	PB1 (7)	I/O	TTL	16/32-Bit Timer 2 Capture/Compare/PWM 1.

Table 22-3. Signals by Signal Name (continued)

Pin Name	Pin Number	Pin Mux / Pin Assignment	Pin Type	Buffer Type ^a	Description
T3CCP0	47	PB2 (7)	I/O	TTL	16/32-Bit Timer 3 Capture/Compare/PWM 0.
T3CCP1	48	PB3 (7)	I/O	TTL	16/32-Bit Timer 3 Capture/Compare/PWM 1.
T4CCP0	37 52	PG0 (7) PC0 (7)	I/O	TTL	16/32-Bit Timer 4 Capture/Compare/PWM 0.
T4CCP1	36 51	PG1 (7) PC1 (7)	I/O	TTL	16/32-Bit Timer 4 Capture/Compare/PWM 1.
T5CCP0	35 50	PG2 (7) PC2 (7)	I/O	TTL	16/32-Bit Timer 5 Capture/Compare/PWM 0.
T5CCP1	34 49	PG3 (7) PC3 (7)	I/O	TTL	16/32-Bit Timer 5 Capture/Compare/PWM 1.
TCK	52	PC0 (1)	I	TTL	JTAG/SWD CLK.
TDI	50	PC2 (1)	I	TTL	JTAG TDI.
TDO	49	PC3 (1)	O	TTL	JTAG TDO and SWO.
TMS	51	PC1 (1)	I	TTL	JTAG TMS and SWDIO.
TRCLK	31	PF3 (14)	O	TTL	Trace clock.
TRD0	30	PF2 (14)	O	TTL	Trace data 0.
TRD1	29	PF1 (14)	O	TTL	Trace data 1.
U0Rx	17	PA0 (1)	I	TTL	UART module 0 receive.
U0Tx	18	PA1 (1)	O	TTL	UART module 0 transmit.
U1CTS	15 29	PC5 (8) PF1 (1)	I	TTL	UART module 1 Clear To Send modem flow control input signal.
U1RTS	16 28	PC4 (8) PF0 (1)	O	TTL	UART module 1 Request to Send modem flow control output line.
U1Rx	16 45	PC4 (2) PB0 (1)	I	TTL	UART module 1 receive.
U1Tx	15 46	PC5 (2) PB1 (1)	O	TTL	UART module 1 transmit.
U2Rx	33 53	PG4 (1) PD6 (1)	I	TTL	UART module 2 receive.
U2Tx	10 32	PD7 (1) PG5 (1)	O	TTL	UART module 2 transmit.
U3Rx	14	PC6 (1)	I	TTL	UART module 3 receive.
U3Tx	13	PC7 (1)	O	TTL	UART module 3 transmit.
U4Rx	16	PC4 (1)	I	TTL	UART module 4 receive.
U4Tx	15	PC5 (1)	O	TTL	UART module 4 transmit.
U5Rx	59	PE4 (1)	I	TTL	UART module 5 receive.
U5Tx	60	PE5 (1)	O	TTL	UART module 5 transmit.
U6Rx	43	PD4 (1)	I	TTL	UART module 6 receive.
U6Tx	44	PD5 (1)	O	TTL	UART module 6 transmit.
U7Rx	9	PE0 (1)	I	TTL	UART module 7 receive.
U7Tx	8	PE1 (1)	O	TTL	UART module 7 transmit.
USB0DM	43	PD4	I/O	Analog	Bidirectional differential data pin (D- per USB specification) for USB0.

Table 22-3. Signals by Signal Name (continued)

Pin Name	Pin Number	Pin Mux / Pin Assignment	Pin Type	Buffer Type ^a	Description
USB0DP	44	PD5	I/O	Analog	Bidirectional differential data pin (D+ per USB specification) for USB0.
USB0EPEN	5 14 33 63	PF4 (8) PC6 (8) PG4 (8) PD2 (8)	O	TTL	Optionally used in Host mode to control an external power source to supply power to the USB bus.
USB0ID	45	PB0	I	Analog	This signal senses the state of the USB ID signal. The USB PHY enables an integrated pull-up, and an external element (USB connector) indicates the initial state of the USB controller (pulled down is the A side of the cable and pulled up is the B side).
USB0PFLT	13 32 64	PC7 (8) PG5 (8) PD3 (8)	I	TTL	Optionally used in Host mode by an external power source to indicate an error state by that power source.
USB0VBUS	46	PB1	I/O	Analog	This signal is used during the session request protocol. This signal allows the USB PHY to both sense the voltage level of VBUS, and pull up VBUS momentarily during VBUS pulsing.
VDD	11 26 42 54	fixed	-	Power	Positive supply for I/O and some logic.
VDDA	2	fixed	-	Power	The positive supply for the analog circuits (ADC, Analog Comparators, etc.). These are separated from VDD to minimize the electrical noise contained on VDD from affecting the analog functions. VDDA pins must be supplied with a voltage that meets the specification in Table 24-2 on page 1323, regardless of system implementation.
VDDC	25 56	fixed	-	Power	Positive supply for most of the logic function, including the processor core and most peripherals. The voltage on this pin is 1.2 V and is supplied by the on-chip LDO. The VDDC pins should only be connected to each other and an external capacitor as specified in Table 24-8 on page 1328 .
WT0CCP0	16 33	PC4 (7) PG4 (7)	I/O	TTL	32/64-Bit Wide Timer 0 Capture/Compare/PWM 0.
WT0CCP1	15 32	PC5 (7) PG5 (7)	I/O	TTL	32/64-Bit Wide Timer 0 Capture/Compare/PWM 1.
WT1CCP0	14	PC6 (7)	I/O	TTL	32/64-Bit Wide Timer 1 Capture/Compare/PWM 0.
WT1CCP1	13	PC7 (7)	I/O	TTL	32/64-Bit Wide Timer 1 Capture/Compare/PWM 1.
WT2CCP0	61	PD0 (7)	I/O	TTL	32/64-Bit Wide Timer 2 Capture/Compare/PWM 0.
WT2CCP1	62	PD1 (7)	I/O	TTL	32/64-Bit Wide Timer 2 Capture/Compare/PWM 1.
WT3CCP0	63	PD2 (7)	I/O	TTL	32/64-Bit Wide Timer 3 Capture/Compare/PWM 0.
WT3CCP1	64	PD3 (7)	I/O	TTL	32/64-Bit Wide Timer 3 Capture/Compare/PWM 1.
WT4CCP0	43	PD4 (7)	I/O	TTL	32/64-Bit Wide Timer 4 Capture/Compare/PWM 0.
WT4CCP1	44	PD5 (7)	I/O	TTL	32/64-Bit Wide Timer 4 Capture/Compare/PWM 1.
WT5CCP0	53	PD6 (7)	I/O	TTL	32/64-Bit Wide Timer 5 Capture/Compare/PWM 0.
WT5CCP1	10	PD7 (7)	I/O	TTL	32/64-Bit Wide Timer 5 Capture/Compare/PWM 1.

a. The TTL designation indicates the pin has TTL-compatible voltage levels.

Table 22-4. Signals by Function, Except for GPIO

Function	Pin Name	Pin Number	Pin Type	Buffer Type ^a	Description
ADC	AIN0	6	I	Analog	Analog-to-digital converter input 0.
	AIN1	7	I	Analog	Analog-to-digital converter input 1.
	AIN2	8	I	Analog	Analog-to-digital converter input 2.
	AIN3	9	I	Analog	Analog-to-digital converter input 3.
	AIN4	64	I	Analog	Analog-to-digital converter input 4.
	AIN5	63	I	Analog	Analog-to-digital converter input 5.
	AIN6	62	I	Analog	Analog-to-digital converter input 6.
	AIN7	61	I	Analog	Analog-to-digital converter input 7.
	AIN8	60	I	Analog	Analog-to-digital converter input 8.
	AIN9	59	I	Analog	Analog-to-digital converter input 9.
	AIN10	58	I	Analog	Analog-to-digital converter input 10.
	AIN11	57	I	Analog	Analog-to-digital converter input 11.
Analog Comparators	C0+	14	I	Analog	Analog comparator 0 positive input.
	C0-	13	I	Analog	Analog comparator 0 negative input.
	C0o	28	O	TTL	Analog comparator 0 output.
	C1+	15	I	Analog	Analog comparator 1 positive input.
	C1-	16	I	Analog	Analog comparator 1 negative input.
	C1o	29	O	TTL	Analog comparator 1 output.
Controller Area Network	CAN0Rx	28 58 59	I	TTL	CAN module 0 receive.
	CAN0Tx	31 57 60	O	TTL	CAN module 0 transmit.
	CAN1Rx	17	I	TTL	CAN module 1 receive.
	CAN1Tx	18	O	TTL	CAN module 1 transmit.
Core	TRCLK	31	O	TTL	Trace clock.
	TRD0	30	O	TTL	Trace data 0.
	TRD1	29	O	TTL	Trace data 1.

Table 22-4. Signals by Function, Except for GPIO (continued)

Function	Pin Name	Pin Number	Pin Type	Buffer Type ^a	Description
General-Purpose Timers	T0CCP0	1 28	I/O	TTL	16/32-Bit Timer 0 Capture/Compare/PWM 0.
	T0CCP1	4 29	I/O	TTL	16/32-Bit Timer 0 Capture/Compare/PWM 1.
	T1CCP0	30 58	I/O	TTL	16/32-Bit Timer 1 Capture/Compare/PWM 0.
	T1CCP1	31 57	I/O	TTL	16/32-Bit Timer 1 Capture/Compare/PWM 1.
	T2CCP0	5 45	I/O	TTL	16/32-Bit Timer 2 Capture/Compare/PWM 0.
	T2CCP1	46	I/O	TTL	16/32-Bit Timer 2 Capture/Compare/PWM 1.
	T3CCP0	47	I/O	TTL	16/32-Bit Timer 3 Capture/Compare/PWM 0.
	T3CCP1	48	I/O	TTL	16/32-Bit Timer 3 Capture/Compare/PWM 1.
	T4CCP0	37 52	I/O	TTL	16/32-Bit Timer 4 Capture/Compare/PWM 0.
	T4CCP1	36 51	I/O	TTL	16/32-Bit Timer 4 Capture/Compare/PWM 1.
	T5CCP0	35 50	I/O	TTL	16/32-Bit Timer 5 Capture/Compare/PWM 0.
	T5CCP1	34 49	I/O	TTL	16/32-Bit Timer 5 Capture/Compare/PWM 1.
	WT0CCP0	16 33	I/O	TTL	32/64-Bit Wide Timer 0 Capture/Compare/PWM 0.
	WT0CCP1	15 32	I/O	TTL	32/64-Bit Wide Timer 0 Capture/Compare/PWM 1.
	WT1CCP0	14	I/O	TTL	32/64-Bit Wide Timer 1 Capture/Compare/PWM 0.
	WT1CCP1	13	I/O	TTL	32/64-Bit Wide Timer 1 Capture/Compare/PWM 1.
	WT2CCP0	61	I/O	TTL	32/64-Bit Wide Timer 2 Capture/Compare/PWM 0.
	WT2CCP1	62	I/O	TTL	32/64-Bit Wide Timer 2 Capture/Compare/PWM 1.
	WT3CCP0	63	I/O	TTL	32/64-Bit Wide Timer 3 Capture/Compare/PWM 0.
	WT3CCP1	64	I/O	TTL	32/64-Bit Wide Timer 3 Capture/Compare/PWM 1.
WT4CCP0	43	I/O	TTL	32/64-Bit Wide Timer 4 Capture/Compare/PWM 0.	
WT4CCP1	44	I/O	TTL	32/64-Bit Wide Timer 4 Capture/Compare/PWM 1.	
WT5CCP0	53	I/O	TTL	32/64-Bit Wide Timer 5 Capture/Compare/PWM 0.	
WT5CCP1	10	I/O	TTL	32/64-Bit Wide Timer 5 Capture/Compare/PWM 1.	

Table 22-4. Signals by Function, Except for GPIO (continued)

Function	Pin Name	Pin Number	Pin Type	Buffer Type ^a	Description
I2C	I2C0SCL	47	I/O	OD	I ² C module 0 clock. Note that this signal has an active pull-up. The corresponding port pin should not be configured as open drain.
	I2C0SDA	48	I/O	OD	I ² C module 0 data.
	I2C1SCL	23 33	I/O	OD	I ² C module 1 clock. Note that this signal has an active pull-up. The corresponding port pin should not be configured as open drain.
	I2C1SDA	24 32	I/O	OD	I ² C module 1 data.
	I2C2SCL	59	I/O	OD	I ² C module 2 clock. Note that this signal has an active pull-up. The corresponding port pin should not be configured as open drain.
	I2C2SDA	60	I/O	OD	I ² C module 2 data.
	I2C3SCL	37 61	I/O	OD	I ² C module 3 clock. Note that this signal has an active pull-up. The corresponding port pin should not be configured as open drain.
	I2C3SDA	36 62	I/O	OD	I ² C module 3 data.
	I2C4SCL	35	I/O	OD	I ² C module 4 clock. Note that this signal has an active pull-up. The corresponding port pin should not be configured as open drain.
	I2C4SDA	34	I/O	OD	I ² C module 4 data.
	I2C5SCL	1	I/O	OD	I ² C module 5 clock. Note that this signal has an active pull-up. The corresponding port pin should not be configured as open drain.
I2C5SDA	4	I/O	OD	I ² C module 5 data.	
JTAG/SWD/SWO	SWCLK	52	I	TTL	JTAG/SWD CLK.
	SWDIO	51	I/O	TTL	JTAG TMS and SWDIO.
	SWO	49	O	TTL	JTAG TDO and SWO.
	TCK	52	I	TTL	JTAG/SWD CLK.
	TDI	50	I	TTL	JTAG TDI.
	TDO	49	O	TTL	JTAG TDO and SWO.
	TMS	51	I	TTL	JTAG TMS and SWDIO.

Table 22-4. Signals by Function, Except for GPIO (continued)

Function	Pin Name	Pin Number	Pin Type	Buffer Type ^a	Description
PWM	MOFAULT0	30 53 63	I	TTL	Motion Control Module 0 PWM Fault 0.
	MOFAULT1	10 31 35	I	TTL	Motion Control Module 0 PWM Fault 1.
	MOFAULT2	5 34	I	TTL	Motion Control Module 0 PWM Fault 2.
	MOPWM0	1	O	TTL	Motion Control Module 0 PWM 0. This signal is controlled by Module 0 PWM Generator 0.
	MOPWM1	4	O	TTL	Motion Control Module 0 PWM 1. This signal is controlled by Module 0 PWM Generator 0.
	MOPWM2	58	O	TTL	Motion Control Module 0 PWM 2. This signal is controlled by Module 0 PWM Generator 1.
	MOPWM3	57	O	TTL	Motion Control Module 0 PWM 3. This signal is controlled by Module 0 PWM Generator 1.
	MOPWM4	33 59	O	TTL	Motion Control Module 0 PWM 4. This signal is controlled by Module 0 PWM Generator 2.
	MOPWM5	32 60	O	TTL	Motion Control Module 0 PWM 5. This signal is controlled by Module 0 PWM Generator 2.
	MOPWM6	16 61	O	TTL	Motion Control Module 0 PWM 6. This signal is controlled by Module 0 PWM Generator 3.
	MOPWM7	15 62	O	TTL	Motion Control Module 0 PWM 7. This signal is controlled by Module 0 PWM Generator 3.
	M1FAULT0	5	I	TTL	Motion Control Module 1 PWM Fault 0.
	M1FAULT1	37	I	TTL	Motion Control Module 1 PWM Fault 1.
	M1FAULT2	36	I	TTL	Motion Control Module 1 PWM Fault 2.
	M1PWM0	35 61	O	TTL	Motion Control Module 1 PWM 0. This signal is controlled by Module 1 PWM Generator 0.
	M1PWM1	34 62	O	TTL	Motion Control Module 1 PWM 1. This signal is controlled by Module 1 PWM Generator 0.
	M1PWM2	23 33 59	O	TTL	Motion Control Module 1 PWM 2. This signal is controlled by Module 1 PWM Generator 1.
	M1PWM3	24 32 60	O	TTL	Motion Control Module 1 PWM 3. This signal is controlled by Module 1 PWM Generator 1.
	M1PWM4	28	O	TTL	Motion Control Module 1 PWM 4. This signal is controlled by Module 1 PWM Generator 2.
	M1PWM5	29	O	TTL	Motion Control Module 1 PWM 5. This signal is controlled by Module 1 PWM Generator 2.
M1PWM6	30	O	TTL	Motion Control Module 1 PWM 6. This signal is controlled by Module 1 PWM Generator 3.	
M1PWM7	31	O	TTL	Motion Control Module 1 PWM 7. This signal is controlled by Module 1 PWM Generator 3.	

Table 22-4. Signals by Function, Except for GPIO (continued)

Function	Pin Name	Pin Number	Pin Type	Buffer Type ^a	Description
Power	GND	12 27 39 55	-	Power	Ground reference for logic and I/O pins.
	GNDA	3	-	Power	The ground reference for the analog circuits (ADC, Analog Comparators, etc.). These are separated from GND to minimize the electrical noise contained on VDD from affecting the analog functions.
	VDD	11 26 42 54	-	Power	Positive supply for I/O and some logic.
	VDDA	2	-	Power	The positive supply for the analog circuits (ADC, Analog Comparators, etc.). These are separated from VDD to minimize the electrical noise contained on VDD from affecting the analog functions. VDDA pins must be supplied with a voltage that meets the specification in Table 24-2 on page 1323, regardless of system implementation.
	VDDC	25 56	-	Power	Positive supply for most of the logic function, including the processor core and most peripherals. The voltage on this pin is 1.2 V and is supplied by the on-chip LDO. The VDDC pins should only be connected to each other and an external capacitor as specified in Table 24-8 on page 1328 .
QEI	IDX0	5 64	I	TTL	QEI module 0 index.
	IDX1	16 32	I	TTL	QEI module 1 index.
	PhA0	28 53	I	TTL	QEI module 0 phase A.
	PhA1	15 34 37	I	TTL	QEI module 1 phase A.
	PhB0	10 29	I	TTL	QEI module 0 phase B.
	PhB1	14 33 36	I	TTL	QEI module 1 phase B.

Table 22-4. Signals by Function, Except for GPIO (continued)

Function	Pin Name	Pin Number	Pin Type	Buffer Type ^a	Description
SSI	SSI0Clk	19	I/O	TTL	SSI module 0 clock
	SSI0Fss	20	I/O	TTL	SSI module 0 frame signal
	SSI0Rx	21	I	TTL	SSI module 0 receive
	SSI0Tx	22	O	TTL	SSI module 0 transmit
	SSI1Clk	30 61	I/O	TTL	SSI module 1 clock
	SSI1Fss	31 62	I/O	TTL	SSI module 1 frame signal
	SSI1Rx	28 63	I	TTL	SSI module 1 receive
	SSI1Tx	29 64	O	TTL	SSI module 1 transmit
	SSI2Clk	58	I/O	TTL	SSI module 2 clock
	SSI2Fss	57	I/O	TTL	SSI module 2 frame signal
	SSI2Rx	1	I	TTL	SSI module 2 receive
	SSI2Tx	4	O	TTL	SSI module 2 transmit
	SSI3Clk	61	I/O	TTL	SSI module 3 clock
	SSI3Fss	62	I/O	TTL	SSI module 3 frame signal
	SSI3Rx	63	I	TTL	SSI module 3 receive
SSI3Tx	64	O	TTL	SSI module 3 transmit	
System Control & Clocks	NMI	10 28	I	TTL	Non-maskable interrupt.
	OSC0	40	I	Analog	Main oscillator crystal input or an external clock reference input.
	OSC1	41	O	Analog	Main oscillator crystal output. Leave unconnected when using a single-ended clock source.
	RST	38	I	TTL	System reset input.

Table 22-4. Signals by Function, Except for GPIO (continued)

Function	Pin Name	Pin Number	Pin Type	Buffer Type ^a	Description
UART	U0Rx	17	I	TTL	UART module 0 receive.
	U0Tx	18	O	TTL	UART module 0 transmit.
	U1CTS	15 29	I	TTL	UART module 1 Clear To Send modem flow control input signal.
	U1RTS	16 28	O	TTL	UART module 1 Request to Send modem flow control output line.
	U1Rx	16 45	I	TTL	UART module 1 receive.
	U1Tx	15 46	O	TTL	UART module 1 transmit.
	U2Rx	33 53	I	TTL	UART module 2 receive.
	U2Tx	10 32	O	TTL	UART module 2 transmit.
	U3Rx	14	I	TTL	UART module 3 receive.
	U3Tx	13	O	TTL	UART module 3 transmit.
	U4Rx	16	I	TTL	UART module 4 receive.
	U4Tx	15	O	TTL	UART module 4 transmit.
	U5Rx	59	I	TTL	UART module 5 receive.
	U5Tx	60	O	TTL	UART module 5 transmit.
	U6Rx	43	I	TTL	UART module 6 receive.
	U6Tx	44	O	TTL	UART module 6 transmit.
	U7Rx	9	I	TTL	UART module 7 receive.
U7Tx	8	O	TTL	UART module 7 transmit.	
USB	USB0DM	43	I/O	Analog	Bidirectional differential data pin (D- per USB specification) for USB0.
	USB0DP	44	I/O	Analog	Bidirectional differential data pin (D+ per USB specification) for USB0.
	USB0EPEN	5 14 33 63	O	TTL	Optionally used in Host mode to control an external power source to supply power to the USB bus.
	USB0ID	45	I	Analog	This signal senses the state of the USB ID signal. The USB PHY enables an integrated pull-up, and an external element (USB connector) indicates the initial state of the USB controller (pulled down is the A side of the cable and pulled up is the B side).
	USB0PFLT	13 32 64	I	TTL	Optionally used in Host mode by an external power source to indicate an error state by that power source.
	USB0VBUS	46	I/O	Analog	This signal is used during the session request protocol. This signal allows the USB PHY to both sense the voltage level of VBUS, and pull up VBUS momentarily during VBUS pulsing.

a. The TTL designation indicates the pin has TTL-compatible voltage levels.

Table 22-5. GPIO Pins and Alternate Functions

IO	Pin	Analog Function	Digital Function (GPIOCTL PMCx Bit Field Encoding) ^a											
			1	2	3	4	5	6	7	8	9	14	15	
PA0	17	-	U0Rx	-	-	-	-	-	-	-	CAN1Rx	-	-	-
PA1	18	-	U0Tx	-	-	-	-	-	-	-	CAN1Tx	-	-	-
PA2	19	-	-	SSI0Clk	-	-	-	-	-	-	-	-	-	-
PA3	20	-	-	SSI0Fss	-	-	-	-	-	-	-	-	-	-
PA4	21	-	-	SSI0Rx	-	-	-	-	-	-	-	-	-	-
PA5	22	-	-	SSI0Tx	-	-	-	-	-	-	-	-	-	-
PA6	23	-	-	-	I2C1SCL	-	M1PWM2	-	-	-	-	-	-	-
PA7	24	-	-	-	I2C1SDA	-	M1PWM3	-	-	-	-	-	-	-
PB0	45	USB0ID	U1Rx	-	-	-	-	-	-	T2CCP0	-	-	-	-
PB1	46	USB0VBUS	U1Tx	-	-	-	-	-	-	T2CCP1	-	-	-	-
PB2	47	-	-	-	I2C0SCL	-	-	-	-	T3CCP0	-	-	-	-
PB3	48	-	-	-	I2C0SDA	-	-	-	-	T3CCP1	-	-	-	-
PB4	58	AIN10	-	SSI2Clk	-	M0PWM2	-	-	-	T1CCP0	CAN0Rx	-	-	-
PB5	57	AIN11	-	SSI2Fss	-	M0PWM3	-	-	-	T1CCP1	CAN0Tx	-	-	-
PB6	1	-	-	SSI2Rx	I2C5SCL	M0PWM0	-	-	-	T0CCP0	-	-	-	-
PB7	4	-	-	SSI2Tx	I2C5SDA	M0PWM1	-	-	-	T0CCP1	-	-	-	-
PC0	52	-	TCK SWCLK	-	-	-	-	-	-	T4CCP0	-	-	-	-
PC1	51	-	TMS SWDIO	-	-	-	-	-	-	T4CCP1	-	-	-	-
PC2	50	-	TDI	-	-	-	-	-	-	T5CCP0	-	-	-	-
PC3	49	-	TDO SWO	-	-	-	-	-	-	T5CCP1	-	-	-	-
PC4	16	C1-	U4Rx	U1Rx	-	M0PWM6	-	IDX1	WT0CCP0	U1RTS	-	-	-	-
PC5	15	C1+	U4Tx	U1Tx	-	M0PWM7	-	PhA1	WT0CCP1	U1CTS	-	-	-	-
PC6	14	C0+	U3Rx	-	-	-	-	PhB1	WT1CCP0	USB0EPEN	-	-	-	-
PC7	13	C0-	U3Tx	-	-	-	-	-	WT1CCP1	USB0PFLT	-	-	-	-
PD0	61	AIN7	SSI3Clk	SSI1Clk	I2C3SCL	M0PWM6	M1PWM0	-	WT2CCP0	-	-	-	-	-
PD1	62	AIN6	SSI3Fss	SSI1Fss	I2C3SDA	M0PWM7	M1PWM1	-	WT2CCP1	-	-	-	-	-
PD2	63	AIN5	SSI3Rx	SSI1Rx	-	M0FAULT0	-	-	WT3CCP0	USB0EPEN	-	-	-	-
PD3	64	AIN4	SSI3Tx	SSI1Tx	-	-	-	IDX0	WT3CCP1	USB0PFLT	-	-	-	-
PD4	43	USB0DM	U6Rx	-	-	-	-	-	WT4CCP0	-	-	-	-	-
PD5	44	USB0DP	U6Tx	-	-	-	-	-	WT4CCP1	-	-	-	-	-
PD6	53	-	U2Rx	-	-	M0FAULT0	-	PhA0	WT5CCP0	-	-	-	-	-
PD7	10	-	U2Tx	-	-	M0FAULT1	-	PhB0	WT5CCP1	NMI	-	-	-	-
PE0	9	AIN3	U7Rx	-	-	-	-	-	-	-	-	-	-	-
PE1	8	AIN2	U7Tx	-	-	-	-	-	-	-	-	-	-	-
PE2	7	AIN1	-	-	-	-	-	-	-	-	-	-	-	-
PE3	6	AIN0	-	-	-	-	-	-	-	-	-	-	-	-
PE4	59	AIN9	U5Rx	-	I2C2SCL	M0PWM4	M1PWM2	-	-	CAN0Rx	-	-	-	-
PE5	60	AIN8	U5Tx	-	I2C2SDA	M0PWM5	M1PWM3	-	-	CAN0Tx	-	-	-	-

Table 22-5. GPIO Pins and Alternate Functions (continued)

IO	Pin	Analog Function	Digital Function (GPIOCTL PMCx Bit Field Encoding) ^a										
			1	2	3	4	5	6	7	8	9	14	15
PF0	28	-	U1RTS	SSI1Rx	CAN0Rx	-	M1PWM4	PhA0	T0CCP0	NMI	C0o	-	-
PF1	29	-	U1CTS	SSI1Tx	-	-	M1PWM5	PhB0	T0CCP1	-	C1o	TRD1	-
PF2	30	-	-	SSI1Clk	-	M0FAULT0	M1PWM6	-	T1CCP0	-	-	TRD0	-
PF3	31	-	-	SSI1Fss	CAN0Tx	M0FAULT1	M1PWM7	-	T1CCP1	-	-	TRCLK	-
PF4	5	-	-	-	-	M0FAULT2	M1FAULT0	IDX0	T2CCP0	USBOEPEN	-	-	-
PG0	37	-	-	-	I2C3SCL	-	M1FAULT1	PhA1	T4CCP0	-	-	-	-
PG1	36	-	-	-	I2C3SDA	-	M1FAULT2	PhB1	T4CCP1	-	-	-	-
PG2	35	-	-	-	I2C4SCL	M0FAULT1	M1PWM0	-	T5CCP0	-	-	-	-
PG3	34	-	-	-	I2C4SDA	M0FAULT2	M1PWM1	PhA1	T5CCP1	-	-	-	-
PG4	33	-	U2Rx	-	I2C1SCL	M0PWM4	M1PWM2	PhB1	WT0CCP0	USBOEPEN	-	-	-
PG5	32	-	U2Tx	-	I2C1SDA	M0PWM5	M1PWM3	IDX1	WT0CCP1	USBOPFLT	-	-	-

a. The digital signals that are shaded gray are the power-on default values for the corresponding GPIO pin. Encodings 10-13 are not used on this device.

Table 22-6. Possible Pin Assignments for Alternate Functions

# of Possible Assignments	Alternate Function	GPIO Function
one	AIN0	PE3
	AIN1	PE2
	AIN10	PB4
	AIN11	PB5
	AIN2	PE1
	AIN3	PE0
	AIN4	PD3
	AIN5	PD2
	AIN6	PD1
	AIN7	PD0
	AIN8	PE5
	AIN9	PE4
	C0+	PC6
	C0-	PC7
	C0o	PF0
	C1+	PC5
	C1-	PC4
	C1o	PF1
	CAN1Rx	PA0
	CAN1Tx	PA1
	I2C0SCL	PB2
	I2C0SDA	PB3
	I2C2SCL	PE4
	I2C2SDA	PE5
	I2C4SCL	PG2
	I2C4SDA	PG3
	I2C5SCL	PB6
	I2C5SDA	PB7
	M0PWM0	PB6
	M0PWM1	PB7
	M0PWM2	PB4
	M0PWM3	PB5
	M1FAULT0	PF4
	M1FAULT1	PG0
	M1FAULT2	PG1
	M1PWM4	PF0
	M1PWM5	PF1
	M1PWM6	PF2
	M1PWM7	PF3
	SSI0Clk	PA2
SSI0Fss	PA3	

Table 22-6. Possible Pin Assignments for Alternate Functions (continued)

# of Possible Assignments	Alternate Function	GPIO Function
	SSI0Rx	PA4
	SSI0Tx	PA5
	SSI2C1k	PB4
	SSI2Fss	PB5
	SSI2Rx	PB6
	SSI2Tx	PB7
	SSI3C1k	PD0
	SSI3Fss	PD1
	SSI3Rx	PD2
	SSI3Tx	PD3
	SWCLK	PC0
	SWDIO	PC1
	SWO	PC3
	T2CCP1	PB1
	T3CCP0	PB2
	T3CCP1	PB3
	TCK	PC0
	TDI	PC2
	TDO	PC3
	TMS	PC1
	TRCLK	PF3
	TRD0	PF2
	TRD1	PF1
	U0Rx	PA0
	U0Tx	PA1
	U3Rx	PC6
	U3Tx	PC7
	U4Rx	PC4
	U4Tx	PC5
	U5Rx	PE4
	U5Tx	PE5
	U6Rx	PD4
	U6Tx	PD5
	U7Rx	PE0
	U7Tx	PE1
	USB0DM	PD4
	USB0DP	PD5
	USB0ID	PB0
	USB0VBUS	PB1
	WT1CCP0	PC6
	WT1CCP1	PC7

Table 22-6. Possible Pin Assignments for Alternate Functions (continued)

# of Possible Assignments	Alternate Function	GPIO Function
	WT2CCP0	PD0
	WT2CCP1	PD1
	WT3CCP0	PD2
	WT3CCP1	PD3
	WT4CCP0	PD4
	WT4CCP1	PD5
	WT5CCP0	PD6
	WT5CCP1	PD7

Table 22-6. Possible Pin Assignments for Alternate Functions (continued)

# of Possible Assignments	Alternate Function	GPIO Function
two	I2C1SCL	PA6 PG4
	I2C1SDA	PA7 PG5
	I2C3SCL	PD0 PG0
	I2C3SDA	PD1 PG1
	IDX0	PD3 PF4
	IDX1	PC4 PG5
	M0FAULT2	PF4 PG3
	M0PWM4	PE4 PG4
	M0PWM5	PE5 PG5
	M0PWM6	PC4 PD0
	M0PWM7	PC5 PD1
	M1PWM0	PD0 PG2
	M1PWM1	PD1 PG3
	NMI	PD7 PF0
	PhA0	PD6 PF0
	PhB0	PD7 PF1
	SSI1C1k	PD0 PF2
	SSI1Fss	PD1 PF3
	SSI1Rx	PD2 PF0
	SSI1Tx	PD3 PF1
	T0CCP0	PB6 PF0
	T0CCP1	PB7 PF1
	T1CCP0	PB4 PF2
	T1CCP1	PB5 PF3
	T2CCP0	PB0 PF4
	T4CCP0	PC0 PG0
	T4CCP1	PC1 PG1
	T5CCP0	PC2 PG2
	T5CCP1	PC3 PG3
	U1CTS	PC5 PF1
	U1RTS	PC4 PF0
	U1Rx	PB0 PC4
	U1Tx	PB1 PC5
	U2Rx	PD6 PG4
U2Tx	PD7 PG5	
WT0CCP0	PC4 PG4	
WT0CCP1	PC5 PG5	

Table 22-6. Possible Pin Assignments for Alternate Functions (*continued*)

# of Possible Assignments	Alternate Function	GPIO Function
three	CAN0Rx	PB4 PE4 PF0
	CAN0Tx	PB5 PE5 PF3
	M0FAULT0	PD2 PD6 PF2
	M0FAULT1	PD7 PF3 PG2
	M1PWM2	PA6 PE4 PG4
	M1PWM3	PA7 PE5 PG5
	PhA1	PC5 PG0 PG3
	PhB1	PC6 PG1 PG4
four	USB0PFLT	PC7 PD3 PG5
	USB0EPEN	PC6 PD2 PF4 PG4

22.1 Connections for Unused Signals

Table 22-7 on page 1320 shows how to handle signals for functions that are not used in a particular system implementation for devices that are in a 64-pin LQFP package. Two options are shown in the table: an acceptable practice and a preferred practice for reduced power consumption and improved EMC characteristics. If a module is not used in a system, and its inputs are grounded, it is important that the clock to the module is never enabled by setting the corresponding bit in the **RCGCx** register.

Table 22-7. Connections for Unused Signals (64-Pin LQFP)

Function	Signal Name	Pin Number	Acceptable Practice	Preferred Practice
GPIO	All unused GPIOs	-	NC	GND
No Connects	NC	-	NC	NC
System Control	OSC0	40	NC	GND
	OSC1	41	NC	NC
	$\overline{\text{RST}}$	38	Pull up as shown in Figure 5-1 on page 216	Connect through a capacitor to GND as close to pin as possible
USB	USB0DM	43	NC	GND
	USB0DP	44	NC	GND

23 Operating Characteristics

Table 23-1. Temperature Characteristics

Characteristic	Symbol	Value	Unit
Industrial operating temperature range	T_A	-40 to +85	°C
Unpowered storage temperature range	T_S	-65 to +150	°C

Table 23-2. Thermal Characteristics

Characteristic	Symbol	Value	Unit
Thermal resistance (junction to ambient) ^a	Θ_{JA}	50 ^b	°C/W
Junction temperature, -40 to +125 ^c	T_J	$T_A + (P \cdot \Theta_{JA})$	°C

a. Junction to ambient thermal resistance Θ_{JA} numbers are determined by a package simulator.

b. Preliminary.

c. Power dissipation is a function of temperature.

Table 23-3. ESD Absolute Maximum Ratings^a

Parameter Name	Min	Nom	Max	Unit
V_{ESDHBM}	-	-	2.0	kV
V_{ESDCDM}	-	-	500	V

a. All Stellaris® parts are ESD tested following the JEDEC standard.

24 Electrical Characteristics

24.1 Maximum Ratings

The maximum ratings are the limits to which the device can be subjected without permanently damaging the device. Device reliability may be adversely affected by exposure to absolute-maximum ratings for extended periods.

Note: The device is not guaranteed to operate properly at the maximum ratings.

Table 24-1. Maximum Ratings

Parameter	Parameter Name ^a	Value		Unit
		Min	Max	
V _{DD}	V _{DD} supply voltage	0	4	V
V _{DDA}	V _{DDA} supply voltage	0	4	V
V _{IN_GPIO}	Input voltage on GPIOs, regardless of whether the microcontroller is powered ^{bc}	-0.3	5.5	V
	Input voltage for PB0 and PB1 when configured as GPIO	-0.3	V _{DD} + 0.3	V
I _{GPIO MAX}	Maximum current per output pin	-	25	mA
I _{NON}	Maximum current into or out of a non-power, non-GPIO, non-XOSCn pin when the microcontroller is unpowered ^d	-	pending ^e	mA

a. Voltages are measured with respect to GND.

b. Applies to static and dynamic signals including overshoot.

c. Refer to Figure 24-1 on page 1323 for a representation of the ESD protection on GPIOs.

d. Refer to Figure 24-2 on page 1323 for a representation of the ESD protection on these pins.

e. Pending characterization.

Important: This device contains circuitry to protect the inputs against damage due to high-static voltages or electric fields; however, it is advised that normal precautions be taken to avoid application of any voltage higher than maximum-rated voltages to this high-impedance circuit. Reliability of operation is enhanced if unused inputs are connected to an appropriate logic voltage level (see “Connections for Unused Signals” on page 1320).

Figure 24-1 on page 1323 shows a diagram of the ESD protection on GPIOs.

Figure 24-1. ESD Protection on GPIOs

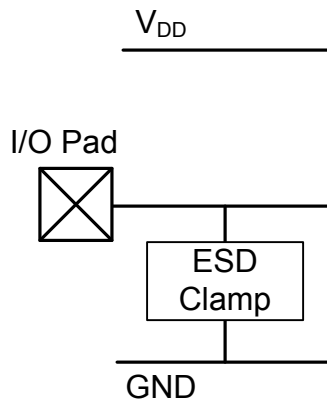
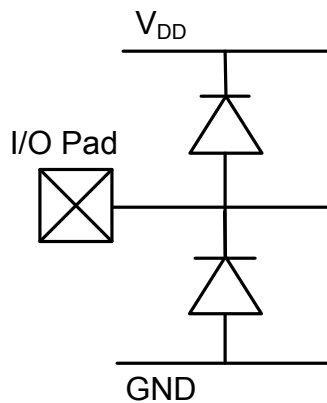

Figure 24-2 on page 1323 shows a diagram of the ESD protection on non-power, non-GPIO, and non-XOSCn pins.

Figure 24-2. ESD Protection on Non-Power, Non-GPIO, and Non-XOSCn Pins



24.2 Recommended Operating Conditions

For special high-current applications, the GPIO output buffers may be used with the following restrictions. With the GPIO pins configured as 8-mA output drivers, a total of four GPIO outputs may be used to sink current loads up to 18 mA each. At 18-mA sink current loading, the V_{OL} value is specified as 1.2 V. The high-current GPIO package pins must be selected such that there are only a maximum of two per side of the physical package with the total number of high-current GPIO outputs not exceeding four for the entire package.

Table 24-2. Recommended DC Operating Conditions

Parameter	Parameter Name	Min	Nom	Max	Unit
V_{DD}	V_{DD} supply voltage	2.97	3.3	3.63	V
V_{DDA}	V_{DDA} supply voltage	2.97	3.3	3.63	V
V_{DDC}	V_{DDC} supply voltage	1.08	1.2	1.32	V
V_{IH}	GPIO high-level input voltage	$0.65 * V_{DD}$	-	V_{DD}	V
V_{IL}	GPIO low-level input voltage	0	-	$0.35 * V_{DD}$	V

Table 24-2. Recommended DC Operating Conditions (continued)

Parameter	Parameter Name	Min	Nom	Max	Unit
V _{HYS}	GPIO Input Hysteresis	0.2	-	-	V
V _{OH}	High-level output voltage	2.4	-	-	V
V _{OL}	Low-level output voltage	-	-	0.4	V
I _{OH}	High-level source current, V _{OH} =2.4 V ^a				
	2-mA Drive	-2.0	-	-	mA
	4-mA Drive	-4.0	-	-	mA
	8-mA Drive	-8.0	-	-	mA
I _{OL}	Low-level sink current, V _{OL} =0.4 V ^a				
	2-mA Drive	2.0	-	-	mA
	4-mA Drive	4.0	-	-	mA
	8-mA Drive	8.0	-	-	mA
	8-mA Drive, V _{OL} =1.2 V	18.0	-	-	mA

a. I_O specifications reflect the maximum current where the corresponding output voltage meets the V_{OH}/V_{OL} thresholds. I_O current can exceed these limits (subject to absolute maximum ratings).

Table 24-3. GPIO Current Restrictions^a

Parameter	Parameter Name	Min	Nom	Max	Unit
I _{MAXL}	Cumulative maximum GPIO current per side, left ^b	-	-	30	mA
I _{MAXB}	Cumulative maximum GPIO current per side, bottom ^b	-	-	35	mA
I _{MAXR}	Cumulative maximum GPIO current per side, right ^b	-	-	40	mA
I _{MAXT}	Cumulative maximum GPIO current per side, top ^b	-	-	40	mA

a. Based on design simulations, not tested in production.

b. Sum of sink and source current for GPIOs as shown in Table 24-4 on page 1324.

Table 24-4. GPIO Package Side Assignments

Side	GPIOs
Left	PB[6-7], PC[4-7], PD7, PE[0-3], PF4
Bottom	PA[0-7], PF[0-3], PG5
Right	PB[0-3], PD[4-5], PG[0-4]
Top	PB[4-5], PC[0-3], PD[0-3,6], PE[4-5]

24.3 Load Conditions

Unless otherwise specified, the following conditions are true for all timing measurements.

Figure 24-3. Load Conditions

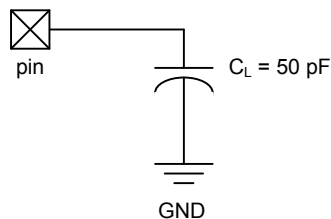

24.4 JTAG and Boundary Scan

Table 24-5. JTAG Characteristics

Parameter No.	Parameter	Parameter Name	Min	Nom	Max	Unit
J1	F_{TCK}	TCK operational clock frequency ^a	0	-	10	MHz
J2	T_{TCK}	TCK operational clock period	100	-	-	ns
J3	T_{TCK_LOW}	TCK clock Low time	-	$t_{TCK}/2$	-	ns
J4	T_{TCK_HIGH}	TCK clock High time	-	$t_{TCK}/2$	-	ns
J5	T_{TCK_R}	TCK rise time	0	-	10	ns
J6	T_{TCK_F}	TCK fall time	0	-	10	ns
J7	T_{TMS_SU}	TMS setup time to TCK rise	8	-	-	ns
J8	T_{TMS_HLD}	TMS hold time from TCK rise	4	-	-	ns
J9	T_{TDI_SU}	TDI setup time to TCK rise	18	-	-	ns
J10	T_{TDI_HLD}	TDI hold time from TCK rise	4	-	-	ns
J11	T_{TDO_ZDV}	TCK fall to Data Valid from High-Z, 2-mA drive	-	13	35	ns
		TCK fall to Data Valid from High-Z, 4-mA drive		9	26	ns
		TCK fall to Data Valid from High-Z, 8-mA drive		8	26	ns
		TCK fall to Data Valid from High-Z, 8-mA drive with slew rate control		10	29	ns
J12	T_{TDO_DV}	TCK fall to Data Valid from Data Valid, 2-mA drive	-	14	20	ns
		TCK fall to Data Valid from Data Valid, 4-mA drive		10	26	ns
		TCK fall to Data Valid from Data Valid, 8-mA drive		8	21	ns
		TCK fall to Data Valid from Data Valid, 8-mA drive with slew rate control		10	26	ns
J13	T_{TDO_DVZ}	TCK fall to High-Z from Data Valid, 2-mA drive	-	7	16	ns
		TCK fall to High-Z from Data Valid, 4-mA drive		7	16	ns
		TCK fall to High-Z from Data Valid, 8-mA drive		7	16	ns
		TCK fall to High-Z from Data Valid, 8-mA drive with slew rate control		8	19	ns

a. A ratio of at least 8:1 must be kept between the system clock and TCK.

Figure 24-4. JTAG Test Clock Input Timing

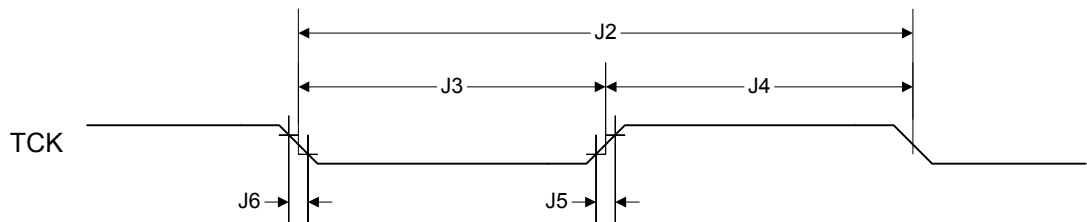
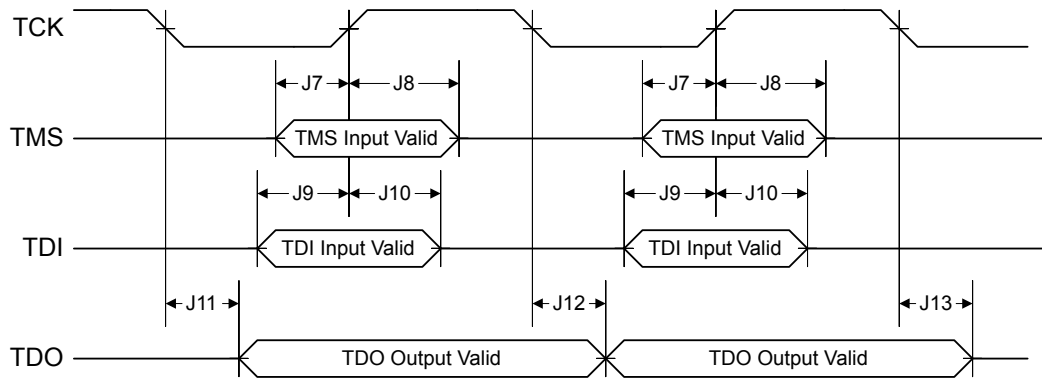

Figure 24-5. JTAG Test Access Port (TAP) Timing



24.5 Power and Brown-Out

Table 24-6. Power Characteristics

Parameter No.	Parameter	Parameter Name	Min	Nom	Max	Unit
P1	$T_{VDDRISE}$	Supply voltage (V_{DD}) rise time	-	-	∞	ms
P2	V_{TH}	Power-On Reset threshold (rising edge)	2.0	2.31	2.6	V
		Power-On Reset threshold (falling edge)	2.0	2.27	2.6	V
P3	V_{BTH}	Brown-Out Reset threshold (rising edge)	2.8	2.92	3.1	V
		Brown-Out Reset threshold (falling edge)	2.8	2.90	3.1	V
P4	T_{POR}	Power-On Reset timeout	-	-	500	μ s
P5	T_{BOR}	Brown-Out Reset timeout	1	-	^a	μ s

a. After the minimum timeout, BOR stays active as long as the power supply is below V_{BTH} . The voltage level is checked every clock cycle after the initial countdown completes. BOR is deasserted on the next clock cycle after the BOR condition goes away.

Figure 24-6. Power-On and Brown-Out Reset and Voltage Parameters

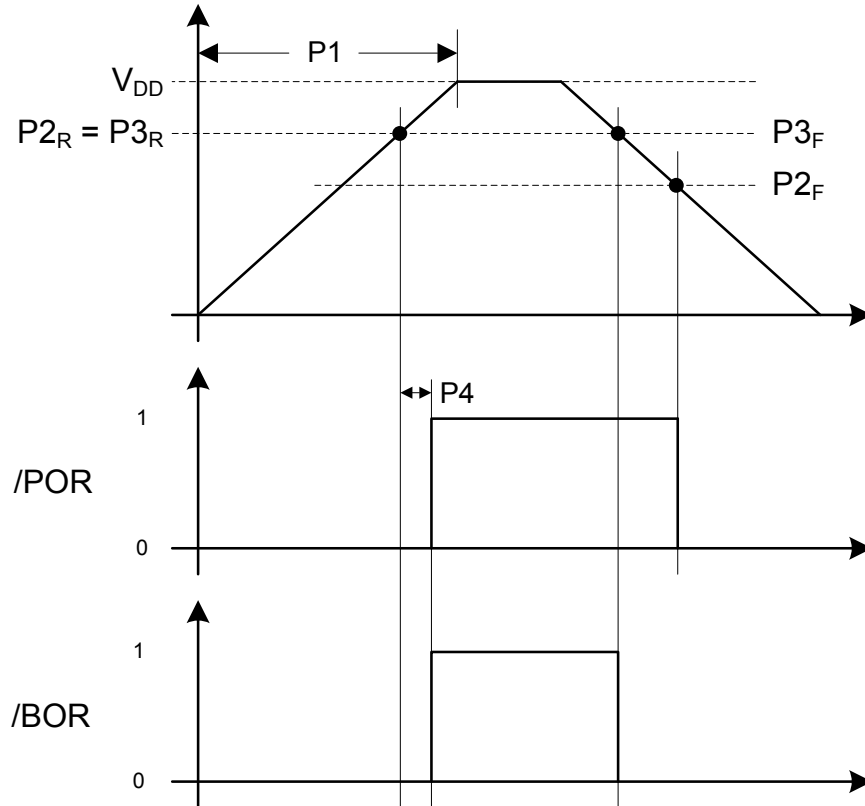
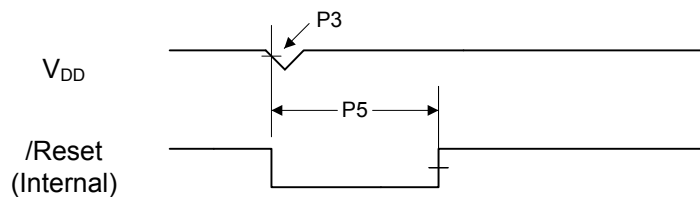

Figure 24-7. Brown-Out Reset Timing



24.6 Reset

Table 24-7. Reset Characteristics

Parameter No.	Parameter	Parameter Name	Min	Nom	Max	Unit
R1	T_{IRHWR}	Internal reset timeout after hardware reset (RST pin) ^a	20	-	- ^b	μs
R2	T_{IRSWR}	Internal reset timeout after software-initiated system reset	-	1	-	μs
R3	T_{IRWDR}	Internal reset timeout after watchdog reset	-	1	-	μs
R4	T_{IRMFR}	Internal reset timeout after MOSC failure reset	-	1	-	μs

Table 24-7. Reset Characteristics (continued)

Parameter No.	Parameter	Parameter Name	Min	Nom	Max	Unit
R5	T_{MIN}	Minimum \overline{RST} pulse width	100	-	-	ns

- a. When in Deep-Sleep mode with the IOSC as the clock source, the internal reset timeout after a hardware reset is $30 \mu s$ * the Deep-sleep clock divider ($DSDIVORIDE$).
- b. After the minimum timeout, internal reset stays active as long as the \overline{RST} pin is asserted, and is released when the \overline{RST} pin is deasserted.

Figure 24-8. External Reset Timing (\overline{RST})

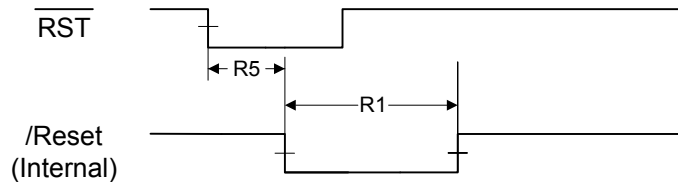

Figure 24-9. Software Reset Timing

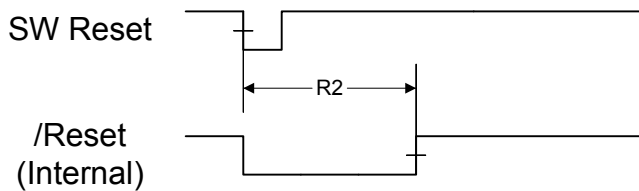

Figure 24-10. Watchdog Reset Timing

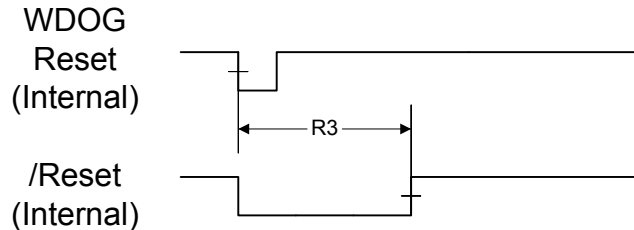
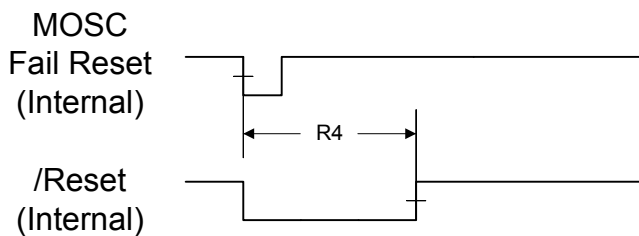

Figure 24-11. MOSC Failure Reset Timing



24.7 On-Chip Low Drop-Out (LDO) Regulator

Table 24-8. LDO Regulator Characteristics

Parameter	Parameter Name	Min	Nom	Max	Unit
C_{LDO}	External filter capacitor size for internal power supply ^a	2.5	-	4.0	μF

Table 24-8. LDO Regulator Characteristics (continued)

Parameter	Parameter Name	Min	Nom	Max	Unit
ESR	Filter capacitor equivalent series resistance	10	-	100	mΩ
ESL	Filter capacitor equivalent series inductance	-	-	0.5	nH
V _{LDO}	LDO output voltage	1.08	1.2	1.32	V
I _{INRUSH}	Inrush current	50	-	250	mA

a. The capacitor should be connected as close as possible to pin 56.

24.8 Clocks

The following sections provide specifications on the various clock sources and mode.

24.8.1 PLL Specifications

The following tables provide specifications for using the PLL.

Table 24-9. Phase Locked Loop (PLL) Characteristics

Parameter	Parameter Name	Min	Nom	Max	Unit
F _{REF_XTAL}	Crystal reference	5 ^a	-	25	MHz
F _{REF_EXT}	External clock reference ^a	5 ^a	-	25	MHz
F _{PLL}	PLL frequency ^b	-	400	-	MHz
T _{READY}	PLL lock time, enabling the PLL	-	-	512 * (N+1) ^c	reference clocks ^d
	PLL lock time, changing the XTAL field in the RCC/RCC2 register or changing the OSCSRC between MOSC and PIOSC	-	-	128 * (N+1) ^c	reference clocks ^d

a. If the PLL is not used, the minimum input frequency can be 4 MHz.

b. PLL frequency is automatically calculated by the hardware based on the XTAL field of the **RCC** register.

c. N is the value in the N field in the **PLLREQ1** register.

d. A reference clock is the clock period of the crystal being used, which can be MOSC or PIOSC. For example, a 16-MHz crystal connected to MOSC yields a reference clock of 62.5 ns.

Table 24-10 on page 1329 shows the actual frequency of the PLL based on the crystal frequency used (defined by the XTAL field in the **RCC** register).

Table 24-10. Actual PLL Frequency

XTAL	Crystal Frequency (MHz)	MINT	MFRAC	Q	N	PLL Multiplier	PLL Frequency (MHz)	Error
0x09	5.0	0x50	0x0	0x0	0x0	80	400	-
0x0A	5.12	0x9C	0x100	0x0	0x1	156.25	400	-
0x0B	6.0	0xC8	0x0	0x0	0x2	200	400	-
0x0C	6.144	0xC3	0x140	0x0	0x2	195.3125	400	-
0x0D	7.3728	0xA2	0x30A	0x0	0x2	162.7598	399.9984	0.0004%
0x0E	8.0	0x32	0x0	0x0	0x0	50	400	-
0x0F	8.192	0xC3	0x140	0x0	0x3	195.3125	400	-
0x10	10.0	0x50	0x0	0x0	0x1	80	400	-
0x11	12.0	0xC8	0x0	0x0	0x5	200	400	-
0x12	12.288	0xC3	0x140	0x0	0x5	195.3125	400	-

Table 24-10. Actual PLL Frequency (continued)

XTAL	Crystal Frequency (MHz)	MINT	MFRAC	Q	N	PLL Multiplier	PLL Frequency (MHz)	Error
0x13	13.56	0xB0	0x3F6	0x0	0x5	176.9902	399.9979	0.0005%
0x14	14.318	0xC3	0x238	0x0	0x6	195.5547	399.9982	0.0005%
0x15	16.0	0x32	0x0	0x0	0x1	50	400	-
0x16	16.384	0xC3	0x140	0x0	0x7	195.3125	400	-
0x17	18	0xC8	0x0	0x0	0x8	200	400	-
0x18	20	0x50	0x0	0x0	0x3	80	400	-
0x19	24	0x32	0x0	0x0	0x2	50	400	-
0x1A	25	0x50	0x0	0x0	0x4	80	400	-

24.8.2 PIOSC Specifications

Table 24-11. PIOSC Clock Characteristics

Parameter	Parameter Name	Min	Nom	Max	Unit
F _{PIOSC25}	Internal 16-MHz precision oscillator frequency variance, factory calibrated at 25 °C	-	±0.25%	±1%	-
F _{PIOSCT}	Internal 16-MHz precision oscillator frequency variance, factory calibrated at 25 °C, across specified temperature range	-	-	±3%	-

24.8.3 Internal 30-kHz Oscillator Specifications

Table 24-12. 30-kHz Clock Characteristics

Parameter	Parameter Name	Min	Nom	Max	Unit
F _{IOSC30KHZ}	Internal 30-KHz oscillator frequency	10	30	90	KHz

24.8.4 Main Oscillator Specifications

Table 24-13. Main Oscillator Input Characteristics

Parameter	Parameter Name	Min	Nom	Max	Unit
F _{MOSC}	Parallel resonance frequency	4 ^a	-	25	MHz
C ₁ , C ₂	External load capacitance on OSC0, OSC1 pins ^b	12	-	24	pF
C _{PKG}	Device package stray shunt capacitance ^b	-	0.5	-	pF
C _{PCB}	PCB stray shunt capacitance ^b	-	0.5	-	pF
C ₀	Crystal shunt capacitance ^{bc}	-	4	-	pF
C _{SHUNT}	Total shunt capacitance ^b	-	-	4	pF
ESR	Crystal effective series resistance, 4 MHz ^{dc}	-	-	300	Ω
	Crystal effective series resistance, 6 MHz ^{dc}	-	-	200	Ω
	Crystal effective series resistance, 8 MHz ^{dc}	-	-	130	Ω
	Crystal effective series resistance, 12 MHz ^{dc}	-	-	120	Ω
	Crystal effective series resistance, 16 MHz ^{dc}	-	-	100	Ω
	Crystal effective series resistance, 25 MHz ^{dc}	-	-	50	Ω

Table 24-13. Main Oscillator Input Characteristics (continued)

Parameter	Parameter Name	Min	Nom	Max	Unit
DL	Oscillator output drive level ^e	-	OSC _{PWR}	-	mW
T _{START}	Oscillator startup time, when using a crystal ^f	-	-	18	ms
V _{IH}	CMOS input high level, when using an external oscillator	0.65 * V _{DD}	-	V _{DD}	V
V _{IL}	CMOS input low level, when using an external oscillator	GND	-	0.35 * V _{DD}	V
V _{HYS}	CMOS input buffer hysteresis, when using an external oscillator	150	-	-	mV
DC _{HIBOSC_EXT}	External clock reference duty cycle	45	-	55	%

a. 5 MHz is the minimum when using the PLL.

b. See information below table.

c. Crystal vendors can be contacted to confirm these specifications are met for a specific crystal part number if the vendors generic crystal datasheet show limits outside of these specifications.

d. Crystal ESR specified by crystal manufacturer.

e. $OSC_{PWR} = (2 * \pi * F_P * C_L * 2.5)^2 * ESR / 2$. An estimation of the typical power delivered to the crystal is based on the C_L, F_P and ESR parameters of the crystal in the circuit as calculated by the OSC_{PWR} equation. Ensure that the value calculated for OSC_{PWR} does not exceed the crystal's drive-level maximum.

f. Oscillator startup time is specified from the time the oscillator is enabled to when it reaches a stable point of oscillation such that the internal clock is valid.

The load capacitors added on the board, C₁ and C₂, should be chosen such that the following equation is satisfied (see Table 24-13 on page 1330 for typical values and Table 24-14 on page 1331 for detailed crystal parameter information).

- C_L = load capacitance specified by crystal manufacturer
- $C_L = (C_1 * C_2) / (C_1 + C_2) + C_{SHUNT}$
- C_{SHUNT} = C₀ + C_{PKG} + C_{PCB} (total shunt capacitance seen across OSC0, OSC1 crystal inputs)
- C_{PKG}, C_{PCB} = the mutual caps as measured across the OSC0, OSC1 pins excluding the crystal.
- C₀ = Shunt capacitance of crystal specified by the crystal manufacturer

Table 24-14. Crystal Parameters

MFG	MFG Part#	Holder	PKG Size (mm x mm)	Freq (MHz)	Crystal Spec	Crystal Parameters						Recommended Component Values			WC DI (uW)
						Typical Values			Max Values			CL1 (pF)	CL2 (pF)	Rs (K Ohm)	
						C0 (pF)	C1 (fF)	L1 (mH)	ESR (Ohm)	Max DI (uW)	C1 (pf)				
NDK	NX8045GB-4.000M-STD-CJL-5	NX8045GB	8 x 4.5	4	STD-CJL-5	1.00	2.70	598.10	300	500	8	12	12	0	132
NDK	NX8045GB-5.000M-STD-CSF-4	NX8045GB	8 x 4.5	5	STD-CJL-4	1.00	2.80	356.50	250	500	8	12	12	0	164

Table 24-14. Crystal Parameters (continued)

MFG	MFG Part#	Holder	PKG Size (mm x mm)	Freq (MHz)	Crystal Spec	Crystal Parameters						Recommended Component Values			WC DI(uW)
						Typical Values			Max Values			CL1(pF)	CL2(pF)	Rs(K Ohm)	
						C0(pF)	C1(fF)	L1(mH)	ESR (Ohm)	Max DI (uW)	CI(pf)				
NDK	NX8045GB- 6.000M-STD- CSF-4	NX8045GB	8 x 4.5	6	STD-CJL-4	1.30	4.10	173.20	250	500	8	12	12	0	214
NDK	NX8045GB- 8.000M-STD- CSF-6	NX8045GB	8 x 4.5	8	STD-CSF-6	1.00	2.80	139.30	200	500	8	12	12	0	277
NDK	NX3225GA- 12.000MHZ- STD-CRG-2	NX3225GA	3.2 x2.5	12	STD-CRG-2	0.70	2.20	81.00	100	200	8	12	12	2.5	147
NDK	NX5032GA- 12.000MHZ- LN-CD-1	NX5032GA	5 x3.2	12	LN-CD-1	0.93	3.12	56.40	120	500	8	12	12	0	362
NDK	NX3225GA- 16.000MHZ- STD-CRG-2	NX3225GA	3.2 x2.5	16	STD-CRG-2	1.00	2.90	33.90	80	200	8	12	12	2	188
NDK	NX5032GA- 16.000MHZ- LN-CD-1	NX5032GA	5 x3.2	16	LN-CD-1	1.02	3.82	25.90	120	500	8	10	12	0	437
NDK	NX3225GA- 25.000MHZ- STD-CRG-2	NX3225GA	3.2 x2.5	25	STD-CRG-2	1.10	4.70	8.70	50	200	8	12	12	2	181
auris	Q-25.000M- HC3225/4- F-30-30-E-12-TR	HC3225/4	3.2 x2.5	25	HC3225	1.58	5.01	8.34	50	500	12	16	16	1	331

Table 24-15. Supported MOSC Crystal Frequencies^a

Value	Crystal Frequency (MHz) Not Using the PLL	Crystal Frequency (MHz) Using the PLL
0x00-0x5	reserved	
0x06	4 MHz	reserved
0x07	4.096 MHz	reserved
0x08	4.9152 MHz	reserved
0x09	5 MHz (USB)	
0x0A	5.12 MHz	
0x0B	6 MHz (USB)	
0x0C	6.144 MHz	
0x0D	7.3728 MHz	
0x0E	8 MHz (USB)	
0x0F	8.192 MHz	

Table 24-15. Supported MOSC Crystal Frequencies (continued)

Value	Crystal Frequency (MHz) Not Using the PLL	Crystal Frequency (MHz) Using the PLL
0x10		10.0 MHz (USB)
0x11		12.0 MHz (USB)
0x12		12.288 MHz
0x13		13.56 MHz
0x14		14.31818 MHz
0x15		16.0 MHz (reset value)(USB)
0x16		16.384 MHz
0x17		18.0 MHz (USB)
0x18		20.0 MHz (USB)
0x19		24.0 MHz (USB)
0x1A		25.0 MHz (USB)

a. Frequencies that may be used with the USB interface are indicated in the table.

24.8.5 System Clock Specification with ADC Operation

Table 24-16. System Clock Characteristics with ADC Operation

Parameter	Parameter Name	Min	Nom	Max	Unit
F _{sysadc}	System clock frequency when the ADC module is operating (when PLL is bypassed). ^a	15.9952	16	16.0048	MHz

a. Clock frequency (plus jitter) must be stable inside specified range. ADC can be clocked from the PLL, directly from an external clock source, or from the PIOSC, as long as frequency absolute precision is inside specified range.

24.8.6 System Clock Specification with USB Operation

Table 24-17. System Clock Characteristics with USB Operation

Parameter	Parameter Name	Min	Nom	Max	Unit
F _{sysusb}	System clock frequency when the USB module is operating (note that MOSC must be the clock source, either with or without using the PLL)	20	-	-	MHz

24.9 Sleep Modes

Table 24-18. Sleep Modes AC Characteristics^a

Parameter No	Parameter	Parameter Name	Min	Nom	Max	Unit
D1	T _{WAKE_S}	Time to wake from interrupt in sleep mode ^b	-	-	2	system clocks
	T _{WAKE_DS}	Time to wake from interrupt in deep-sleep mode, using PIOSC for both Run mode and Deep-sleep mode ^{b c}	-	1.25	-	µs
		Time to wake from interrupt in deep-sleep mode, using PIOSC for Run mode and IOSC for Deep-sleep mode ^{b c}	-	350	-	µs
D2	T _{WAKE_PLL_DS}	Time to wake from interrupt in deep-sleep mode when using the PLL ^b	-	-	T _{READY}	ms

a. Values in this table assume the IOSC is the clock source during sleep or deep-sleep mode.

- b. Specified from registering the interrupt to first instruction.
 c. If the main oscillator is used for run mode, add the main oscillator startup time, T_{START} .

24.10 Flash Memory and EEPROM

Table 24-19. Flash Memory Characteristics

Parameter	Parameter Name	Min	Nom	Max	Unit
PE_{CYC}	Number of guaranteed program/erase cycles before failure ^a	100,000	-	-	cycles
T_{RET}	Data retention, -40°C to +85°C	10	-	-	years
T_{PROG64}	Program time for double-word-aligned 64 bits of data ^b	30	50	300	µs
T_{ERASE}	Page erase time, <1k cycles endurance	2	25	-	ms
	Page erase time, 100k cycles endurance	-	-	900	ms
T_{ME}	Mass erase time, <1k cycles endurance	70	200	-	ms
	Mass erase time, 100k cycles endurance	-	-	900	ms

- a. A program/erase cycle is defined as switching the bits from 1-> 0 -> 1.
 b. If programming fewer than 64 bits of data, the programming time is the same. For example, if only 32 bits of data need to be programmed, the other 32 bits are masked off.

Table 24-20. EEPROM Characteristics^a

Parameter	Parameter Name	Min	Nom	Max	Unit
EPE_{CYC}	Number of guaranteed mass program/erase cycles of a single word before failure ^b	500,000	-	-	cycles
ET_{RET}	Data retention, -40°C to +85°C	10	-	-	years
ET_{PROG}	Program time for 32 bits of data - space available	-	110	600	µs
	Program time for 32 bits of data - requires a copy to the copy buffer, copy buffer has space and less than 10% of EEPROM endurance used	-	30	-	ms
	Program time for 32 bits of data - requires a copy to the copy buffer, copy buffer has space and greater than 90% of EEPROM endurance used	-	-	900	ms
	Program time for 32 bits of data - requires a copy to the copy buffer, copy buffer requires an erase and less than 10% of EEPROM endurance used	-	60	-	ms
	Program time for 32 bits of data - requires a copy to the copy buffer, copy buffer requires an erase and greater than 90% of EEPROM endurance used	-	-	1800	ms
ET_{READ}	Read access time	-	4	-	system clocks
ET_{ME}	Mass erase time, <1k cycles endurance	70	200	-	ms
	Mass erase time, 100k cycles endurance	-	-	900	ms

- a. Because the EEPROM operates as a background task and does not prevent the CPU from executing from Flash memory, the operation will complete within the maximum time specified provided the EEPROM operation is not stalled by a Flash memory program or erase operation.
 b. A program/erase cycle is defined as switching the bits from 1-> 0 -> 1.

24.11 Input/Output Characteristics

Note: All GPIOs are 5-V tolerant, except $PB0$ and $PB1$. See “Signal Description” on page 623 for more information on GPIO configuration.

Table 24-21. GPIO Module Characteristics^{ab}

Parameter	Parameter Name	Min	Nom	Max	Unit
R _{GPIOPU}	GPIO internal pull-up resistor	13	20	30	kΩ
R _{GPIOPD}	GPIO internal pull-down resistor	13	20	35	kΩ
I _{LKG+}	GPIO input leakage current, $0\text{ V} \leq V_{IN} \leq V_{DD}$ GPIO pins ^c	-	-	1.0	μA
	GPIO input leakage current, $0\text{ V} < V_{IN} \leq V_{DD}$, GPIO pins configured as ADC or analog comparator inputs	-	-	2.0	μA
	GPIO input leakage current, $V_{DD} < V_{IN} \leq 4.0\text{ V}$ ^{cd}	-	-	700	μA
	GPIO input leakage current, $4.0\text{ V} < V_{IN} \leq 5.5\text{ V}$ ^{ce}	-	-	100	μA
I _{LKG-}	GPIO input leakage current, $-0.3\text{ V} \leq V_{IN} < 0\text{ V}$ ^c	-	-	10	μA
	GPIO input leakage current, $V_{IN} < -0.3\text{ V}$ ^c	-	-	- ^f	μA
I _{INJ+}	DC injection current, $V_{DD} < V_{IN} \leq 5.5\text{ V}$ ^g	-	-	I _{LKG+}	μA
I _{INJ-}	DC injection current, $V_{IN} \leq 0\text{ V}$	-	-	0.5	mA
T _{GPIOR}	GPIO rise time, 2-mA drive ^h	-	14.2	16.1	ns
	GPIO rise time, 4-mA drive ^h		11.9	15.5	ns
	GPIO rise time, 8-mA drive ^h		8.1	11.2	ns
	GPIO rise time, 8-mA drive with slew rate control ^h		9.5	11.8	ns
T _{GPIOF}	GPIO fall time, 2-mA drive ⁱ	-	25.2	29.4	ns
	GPIO fall time, 4-mA drive ⁱ		13.3	16.8	ns
	GPIO fall time, 8-mA drive ⁱ		8.6	11.2	ns
	GPIO fall time, 8-mA drive with slew rate control ⁱ		11.3	12.9	ns

a. V_{DD} must be within the range specified in Table 24-2 on page 1323.

b. Leakage and Injection current characteristics specified in this table also apply to XOSC0 and XOSC1 inputs.

c. The leakage current is measured with V_{IN} applied to the corresponding pin(s). The leakage of digital port pins is measured individually. The port pin is configured as an input and the pullup/pulldown resistor is disabled.

d. To protect internal circuitry from over-voltage, the GPIOs have an internal voltage clamp that limits internal swings to V_{DD} without affecting swing at the I/O pad. This internal clamp starts turning on while V_{DD} < V_{IN} < 4.0 V and causes a somewhat larger (but bounded) current draw. To save power, static input voltages between V_{DD} and 4 V should be avoided.

e. Leakage current above maximum voltage (V_{IN} = 5.5V) is not guaranteed, this condition is not allowed and can result in permanent damage to the device.

f. In this case, I_{LKG-} is unbounded and must be limited to I_{INJ-} using an external resistor.

g. Current injection is internally bounded for GPIOs, and maximum current into the pin is given by I_{LKG+} for V_{DD} < V_{IN} < 5.5 V.

h. Time measured from 20% to 80% of V_{DD}.

i. Time measured from 80% to 20% of V_{DD}.

24.12 Analog-to-Digital Converter (ADC)

Table 24-22. ADC Electrical Characteristics^a

Parameter	Parameter Name	Min	Nom	Max	Unit
POWER SUPPLY REQUIREMENTS					
V _{DDA}	ADC supply voltage	2.97	3.3	3.63	V
G _{DA}	ADC ground voltage	-	0	-	V
V _{DDA} / G _{DA} VOLTAGE REFERENCE					
C _{REF}	Voltage reference decoupling capacitance	-	1.0 // 0.01 ^b	-	μF
ANALOG INPUT					

Table 24-22. ADC Electrical Characteristics (continued)

Parameter	Parameter Name	Min	Nom	Max	Unit
V _{ADCIN}	Single-ended, full-scale analog input voltage, internal reference ^{cd}	0	-	V _{DDA}	V
	Differential, full-scale analog input voltage, internal reference ^{ce}	-V _{DDA}	-	V _{DDA}	V
V _{INCM}	Input common mode voltage, differential mode ^f	-	-	(V _{REFP} + V _{REFN}) / 2 ± 25	mV
I _L	ADC input leakage current ^g	-	-	2.0	μA
R _{ADC}	ADC equivalent input resistance ^g	-	-	2.5	kΩ
C _{ADC}	ADC equivalent input capacitance ^g	-	-	10	pF
R _S	Analog source resistance ^g	-	-	500	Ω
SAMPLING DYNAMICS					
F _{ADC}	ADC conversion clock frequency ^h	-	16	-	MHz
F _{CONV}	ADC conversion rate	1			MSPS
T _S	ADC sample time	-	250	-	ns
T _C	ADC conversion time	1			μs
T _{LT}	Latency from trigger to start of conversion	-	2	-	ADC clocks
SYSTEM PERFORMANCE when using internal reference					
N	Resolution	12			bits
INL	Integral nonlinearity error, over full input range	-	±1.5	±3.0	LSB
DNL	Differential nonlinearity error, over full input range	-	±0.8	±1.0	LSB
E _O	Offset error	-	±5.0	±15.0	LSB
E _G	Gain error ⁱ	-	±10.0	±30.0	LSB
E _T	Total unadjusted error, over full input range ^j	-	±10.0	±30.0	LSB
TEMPERATURE SENSOR					
V _{TSENS}	Temperature sensor voltage, junction temperature 25 °C	-	1.633	-	V
S _{TSENS}	Temperature sensor slope, ambient temperature -40 °C to 85 °C	-	-13.3	-	mV/°C
E _{TSENS}	Temperature sensor accuracy, ambient temperature -40 °C to 85 °C ^k	-	-	±5	°C

a. At ambient temperature = -40 °C to 85 °C, V_{REF+} = 3.3V, F_{ADC} = 16 MHz unless otherwise noted.

b. Two capacitors in parallel.

c. Internal reference is connected directly between V_{DDA} and GNDA (V_{REFi} = V_{DDA} - GNDA). In this mode, E_O, E_G, E_T, and dynamic specifications are adversely affected due to internal voltage drop and noise on V_{DDA} and GNDA.

d. V_{ADCIN} = V_{INP} - V_{INN}

e. With signal common mode as V_{DDA}/2.

f. This parameter is defined as the average of the differential inputs.

g. As shown in Figure 24-12 on page 1337, R_{ADC} is the total equivalent resistance in the input line all the way up to the sampling node at the input of the ADC.

h. See "System Clock Specification with ADC Operation" on page 1333 for full ADC clock frequency specification.

i. Gain error is measured at max code after compensating for offset. Gain error is equivalent to "Full Scale Error." It can be given in % of slope error, or in LSB, as done here.

- j. Total Unadjusted Error is the maximum error at any one code versus the ideal ADC curve. It includes all other errors (offset error, gain error and INL) at any given ADC code.
- k. Note that this parameter does not include ADC error.

Figure 24-12. ADC Input Equivalency Diagram

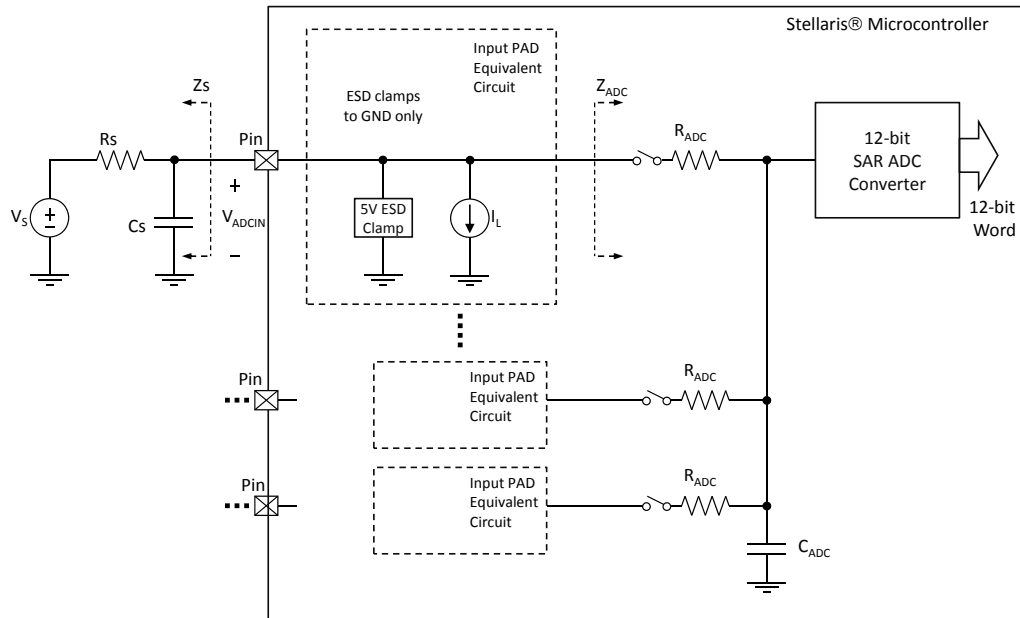

24.13 Synchronous Serial Interface (SSI)

Table 24-23. SSI Characteristics

Parameter No.	Parameter	Parameter Name	Min	Nom	Max	Unit
S1	T_{CLK_PER}	SSIClk cycle time ^a	40	-	-	ns
S2	T_{CLK_HIGH}	SSIClk high time	-	0.5	-	t clk_per
S3	T_{CLK_LOW}	SSIClk low time	-	0.5	-	t clk_per
S4	T_{CLKR}	SSIClk rise time ^b	-	8.1	11.2	ns
S5	T_{CLKF}	SSIClk fall time ^b	-	8.6	11.2	ns
S6	T_{DMD}	Data from master valid delay time	0	-	1	system clocks
S7	T_{DMS}	Data from master setup time	1	-	-	system clocks
S8	T_{DMH}	Data from master hold time	2	-	-	system clocks
S9	T_{DSS}	Data from slave setup time	1	-	-	system clocks

Table 24-23. SSI Characteristics (continued)

Parameter No.	Parameter	Parameter Name	Min	Nom	Max	Unit
S10	T _{DSH}	Data from slave hold time	2	-	-	system clocks

- a. In master mode, the system clock must be at least twice as fast as the SSIClk; in slave mode, the system clock must be at least 6 times faster than the SSIClk.
- b. Note that the delays shown are using 8-mA drive strength.

Figure 24-13. SSI Timing for TI Frame Format (FRF=01), Single Transfer Timing Measurement

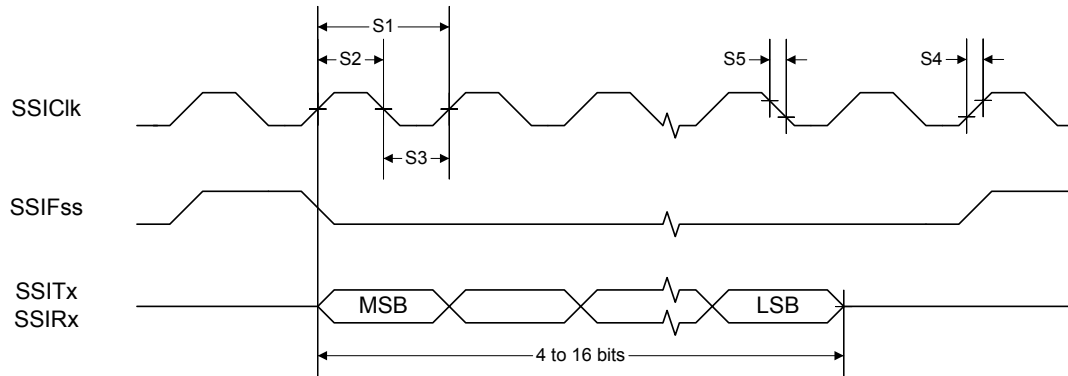

Figure 24-14. SSI Timing for MICROWIRE Frame Format (FRF=10), Single Transfer

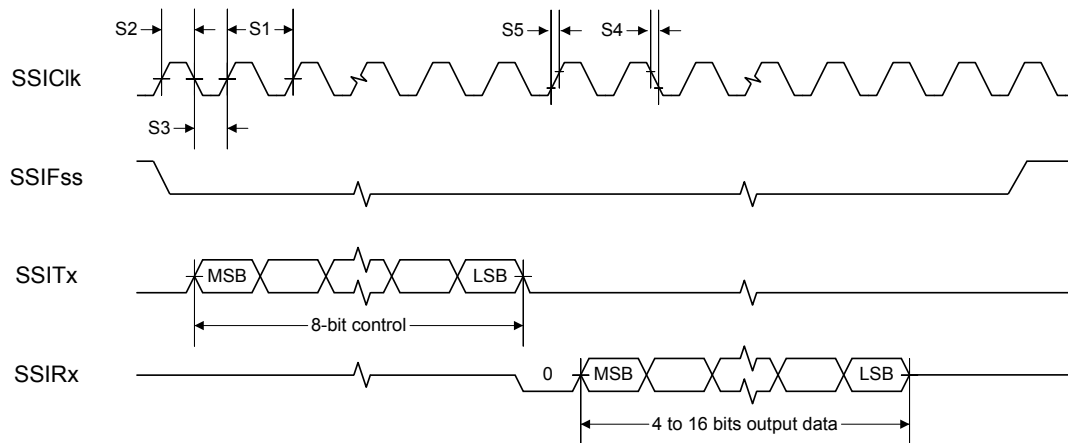
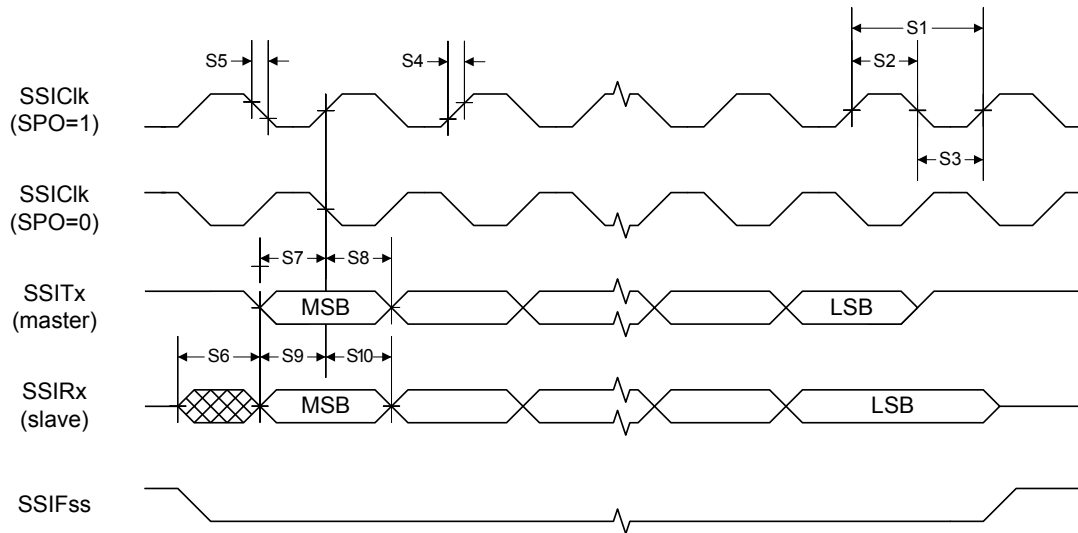

Figure 24-15. SSI Timing for SPI Frame Format (FRF=00), with SPH=1



24.14 Inter-Integrated Circuit (I²C) Interface

Table 24-24. I²C Characteristics

Parameter No.	Parameter	Parameter Name	Min	Nom	Max	Unit
11 ^a	T _{SCH}	Start condition hold time	36	-	-	system clocks
12 ^a	T _{LP}	Clock Low period	36	-	-	system clocks
13 ^b	T _{SRT}	I ² C SCL/I ² C SDA rise time (V _{IL} = 0.5 V to V _{IH} = 2.4 V)	-	-	(see note b)	ns
14 ^a	T _{DH}	Data hold time	2	-	-	system clocks
15 ^c	T _{SFT}	I ² C SCL/I ² C SDA fall time (V _{IH} = 2.4 V to V _{IL} = 0.5 V)	-	9	10	ns
16 ^a	T _{HT}	Clock High time	24	-	-	system clocks
17 ^a	T _{DS}	Data setup time	18	-	-	system clocks
18 ^a	T _{SCSR}	Start condition setup time (for repeated start condition only)	36	-	-	system clocks
19 ^a	T _{SCS}	Stop condition setup time	24	-	-	system clocks

a. Values depend on the value programmed into the TPR bit in the I²C Master Timer Period (I2CMTPR) register; a TPR programmed for the maximum I²C SCL frequency (TPR=0x2) results in a minimum output timing as shown in the table above. The I²C interface is designed to scale the actual data transition time to move it to the middle of the I²C SCL Low period. The actual position is affected by the value programmed into the TPR; however, the numbers given in the above values are minimum values.

b. Because I²C SCL and I²C SDA operate as open-drain-type signals, which the controller can only actively drive Low, the time I²C SCL or I²C SDA takes to reach a high level depends on external signal capacitance and pull-up resistor values.

c. Specified at a nominal 50 pF load.

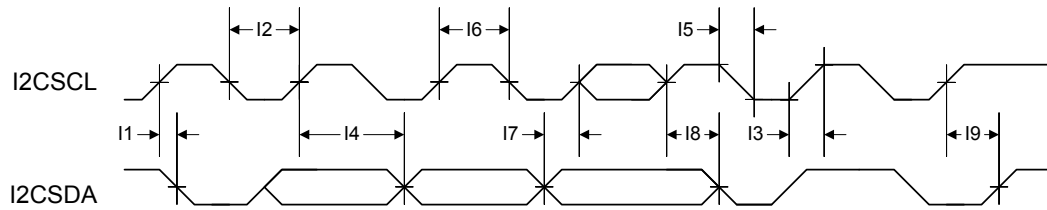
Figure 24-16. I²C Timing

24.15 Universal Serial Bus (USB) Controller

The Stellaris[®] USB controller electrical specifications are compliant with the *Universal Serial Bus Specification Rev. 2.0* (full-speed and low-speed support) and the *On-The-Go Supplement to the USB 2.0 Specification Rev. 1.0*. Some components of the USB system are integrated within the LM4F231H5QR microcontroller and specific to the Stellaris microcontroller design.

24.16 Analog Comparator

Table 24-25. Analog Comparator Characteristics

Parameter	Parameter Name	Min	Nom	Max	Unit
V_{INP}, V_{INN}	Input voltage range	GNDA	-	V_{DDA}	V
V_{CM}	Input common mode voltage range	GNDA	-	V_{DDA}	V
V_{OS}	Input offset voltage	-	± 10	$\pm 25^a$	mV
I_{INP}, I_{INN}	Input leakage current over full voltage range	-	-	2.0	μA
C_{MRR}	Common mode rejection ratio	-	50	-	dB
T_{RT}	Response time	-	-	1.0^b	μs
T_{MC}	Comparator mode change to Output Valid	-	-	10	μs

a. Measured at $V_{REF}=100$ mV.

b. Measured at external $V_{REF}=100$ mV, input signal switching from 75 mV to 125 mV.

Table 24-26. Analog Comparator Voltage Reference Characteristics

Parameter	Parameter Name	Min	Nom	Max	Unit
R_{HR}	Resolution in high range	-	$V_{DDA}/29.4$	-	V
R_{LR}	Resolution in low range	-	$V_{DDA}/22.12$	-	V
A_{HR}	Absolute accuracy high range	-	-	$\pm R_{HR}/2$	V
A_{LR}	Absolute accuracy low range	-	-	$\pm R_{LR}/2$	V

Table 24-27. Analog Comparator Voltage Reference Characteristics, $V_{DDA} = 3.3V$, $EN = 1$, and $RNG = 0$

V_{REF} Value	V_{IREF} Min	Ideal V_{IREF}	V_{IREF} Max	Unit
0x0	0.731	0.786	0.841	V
0x1	0.843	0.898	0.953	V
0x2	0.955	1.010	1.065	V
0x3	1.067	1.122	1.178	V
0x4	1.180	1.235	1.290	V
0x5	1.292	1.347	1.402	V

Table 24-27. Analog Comparator Voltage Reference Characteristics, $V_{DDA} = 3.3V$, $EN = 1$, and $RNG = 0$ (continued)

V_{REF} Value	V_{IREF} Min	Ideal V_{IREF}	V_{IREF} Max	Unit
0x6	1.404	1.459	1.514	V
0x7	1.516	1.571	1.627	V
0x8	1.629	1.684	1.739	V
0x9	1.741	1.796	1.851	V
0xA	1.853	1.908	1.963	V
0xB	1.965	2.020	2.076	V
0xC	2.078	2.133	2.188	V
0xD	2.190	2.245	2.300	V
0xE	2.302	2.357	2.412	V
0xF	2.414	2.469	2.525	V

Table 24-28. Analog Comparator Voltage Reference Characteristics, $V_{DDA} = 3.3V$, $EN = 1$, and $RNG = 1$

V_{REF} Value	V_{IREF} Min	Ideal V_{IREF}	V_{IREF} Max	Unit
0x0	0.000	0.000	0.074	V
0x1	0.076	0.149	0.223	V
0x2	0.225	0.298	0.372	V
0x3	0.374	0.448	0.521	V
0x4	0.523	0.597	0.670	V
0x5	0.672	0.746	0.820	V
0x6	0.822	0.895	0.969	V
0x7	0.971	1.044	1.118	V
0x8	1.120	1.193	1.267	V
0x9	1.269	1.343	1.416	V
0xA	1.418	1.492	1.565	V
0xB	1.567	1.641	1.715	V
0xC	1.717	1.790	1.864	V
0xD	1.866	1.939	2.013	V
0xE	2.015	2.089	2.162	V
0xF	2.164	2.238	2.311	V

24.17 Current Consumption

24.17.1 Preliminary Current Consumption

The following table provides preliminary figures for current consumption while ongoing characterization is completed.

Table 24-29. Preliminary Current Consumption

Parameter	Parameter Name	Conditions	Nom	Max	Unit
I_{DD_RUN}	Run mode 1 (Flash loop)	$V_{DD} = 3.3\text{ V}$ $V_{DDA} = 3.3\text{ V}$ Peripherals = All ON System Clock = 80 MHz (with PLL) Temp = 25°C	50	-	mA
	Run mode 1 (SRAM loop)	$V_{DD} = 3.3\text{ V}$ $V_{DDA} = 3.3\text{ V}$ Peripherals = All ON System Clock = 80 MHz (with PLL) Temp = 25°C	40	-	mA
	Run mode 2 (Flash loop)	$V_{DD} = 3.3\text{ V}$ $V_{DDA} = 3.3\text{ V}$ Peripherals = All OFF System Clock = 80 MHz (with PLL) Temp = 25°C	30	-	mA
	Run mode 2 (SRAM loop)	$V_{DD} = 3.3\text{ V}$ $V_{DDA} = 3.3\text{ V}$ Peripherals = All OFF System Clock = 80 MHz (with PLL) Temp = 25°C	20	-	mA
$I_{DDA_RUN}^a$	Run mode	$V_{DD} = 3.6\text{ V}$ $V_{DDA} = 3.6\text{ V}$ Peripherals = All ON System Clock = 80 MHz (with PLL) Temp = 25°C	-	4.5	mA
I_{DD_SLEEP}	Sleep mode	$V_{DD} = 3.3\text{ V}$ $V_{DDA} = 3.3\text{ V}$ Peripherals = All OFF System Clock = 80 MHz (with PLL) Temp = 25°C	12	-	mA
		$V_{DD} = 3.3\text{ V}$ $V_{DDA} = 3.3\text{ V}$ Peripherals = All OFF System Clock = 16 MHz (with PIOSC) ^b Temp = 25°C	4.5	-	mA
		$V_{DD} = 3.3\text{ V}$ $V_{DDA} = 3.3\text{ V}$ Peripherals = All OFF System Clock = 1 MHz (with PIOSC/16) ^b Temp = 25°C	3.8	-	mA

Table 24-29. Preliminary Current Consumption (continued)

Parameter	Parameter Name	Conditions	Nom	Max	Unit
I _{DD_DEEPSLEEP}	Deep-sleep mode	V _{DD} = 3.3 V V _{DDA} = 3.3 V Peripherals = All OFF System Clock = IOS30KHZ Temp = 25°C	1.05	-	mA

- a. The value for I_{DDA_RUN} is included in the above values for I_{DD_RUN}.
- b. Note that if the MOSC is the source of the Run-mode system clock and is powered down in Sleep mode, wake time is increased by T_{MOSC_SETTLE}.

A Register Quick Reference

31	30	29	28	27	26	25	24	23	22	21	20	19	18	17	16
15	14	13	12	11	10	9	8	7	6	5	4	3	2	1	0
The Cortex-M4F Processor															
R0, type R/W, , reset - (see page 78)															
DATA															
DATA															
R1, type R/W, , reset - (see page 78)															
DATA															
DATA															
R2, type R/W, , reset - (see page 78)															
DATA															
DATA															
R3, type R/W, , reset - (see page 78)															
DATA															
DATA															
R4, type R/W, , reset - (see page 78)															
DATA															
DATA															
R5, type R/W, , reset - (see page 78)															
DATA															
DATA															
R6, type R/W, , reset - (see page 78)															
DATA															
DATA															
R7, type R/W, , reset - (see page 78)															
DATA															
DATA															
R8, type R/W, , reset - (see page 78)															
DATA															
DATA															
R9, type R/W, , reset - (see page 78)															
DATA															
DATA															
R10, type R/W, , reset - (see page 78)															
DATA															
DATA															
R11, type R/W, , reset - (see page 78)															
DATA															
DATA															
R12, type R/W, , reset - (see page 78)															
DATA															
DATA															
SP, type R/W, , reset - (see page 79)															
SP															
SP															
LR, type R/W, , reset 0xFFFF.FFFF (see page 80)															
LINK															
LINK															
PC, type R/W, , reset - (see page 81)															
PC															
PC															

31	30	29	28	27	26	25	24	23	22	21	20	19	18	17	16	
15	14	13	12	11	10	9	8	7	6	5	4	3	2	1	0	
PSR, type R/W, , reset 0x0100.0000 (see page 82)																
N	Z	C	V	Q	ICI / IT		THUMB					GE				
ICI / IT								ISRNUM								
PRIMASK, type R/W, , reset 0x0000.0000 (see page 86)																
															PRIMASK	
FAULTMASK, type R/W, , reset 0x0000.0000 (see page 87)																
															FAULTMASK	
BASEPRI, type R/W, , reset 0x0000.0000 (see page 88)																
								BASEPRI								
CONTROL, type R/W, , reset 0x0000.0000 (see page 89)																
												FPCA	ASP	TMPL		
FPSC, type R/W, , reset - (see page 91)																
N	Z	C	V	AHP		DN	FZ	RMODE				IXC	UFC	OFC	DZC	IOC
								IDC			IXC	UFC	OFC	DZC	IOC	
Cortex-M4 Peripherals																
System Timer (SysTick) Registers																
Base 0xE000.E000																
STCTRL, type R/W, offset 0x010, reset 0x0000.0004																
												CLK_SRC	INTEN	COUNT	ENABLE	
STRELOAD, type R/W, offset 0x014, reset -																
								RELOAD								
RELOAD																
STCURRENT, type R/W, offset 0x018, reset -																
								CURRENT								
CURRENT																
Cortex-M4 Peripherals																
Nested Vectored Interrupt Controller (NVIC) Registers																
Base 0xE000.E000																
EN0, type R/W, offset 0x100, reset 0x0000.0000																
												INT				
												INT				
EN1, type R/W, offset 0x104, reset 0x0000.0000																
												INT				
												INT				
EN2, type R/W, offset 0x108, reset 0x0000.0000																
												INT				
												INT				
EN3, type R/W, offset 0x10C, reset 0x0000.0000																
												INT				
												INT				
EN4, type R/W, offset 0x110, reset 0x0000.0000																
												INT				
												INT				
DIS0, type R/W, offset 0x180, reset 0x0000.0000																
												INT				
												INT				

31	30	29	28	27	26	25	24	23	22	21	20	19	18	17	16
15	14	13	12	11	10	9	8	7	6	5	4	3	2	1	0
DIS1, type R/W, offset 0x184, reset 0x0000.0000															
INT															
INT															
DIS2, type R/W, offset 0x188, reset 0x0000.0000															
INT															
INT															
DIS3, type R/W, offset 0x18C, reset 0x0000.0000															
INT															
INT															
DIS4, type R/W, offset 0x190, reset 0x0000.0000															
INT															
PEND0, type R/W, offset 0x200, reset 0x0000.0000															
INT															
INT															
PEND1, type R/W, offset 0x204, reset 0x0000.0000															
INT															
INT															
PEND2, type R/W, offset 0x208, reset 0x0000.0000															
INT															
INT															
PEND3, type R/W, offset 0x20C, reset 0x0000.0000															
INT															
INT															
PEND4, type R/W, offset 0x210, reset 0x0000.0000															
INT															
UNPEND0, type R/W, offset 0x280, reset 0x0000.0000															
INT															
INT															
UNPEND1, type R/W, offset 0x284, reset 0x0000.0000															
INT															
INT															
UNPEND2, type R/W, offset 0x288, reset 0x0000.0000															
INT															
INT															
UNPEND3, type R/W, offset 0x28C, reset 0x0000.0000															
INT															
INT															
UNPEND4, type R/W, offset 0x290, reset 0x0000.0000															
INT															
ACTIVE0, type RO, offset 0x300, reset 0x0000.0000															
INT															
INT															
ACTIVE1, type RO, offset 0x304, reset 0x0000.0000															
INT															
INT															
ACTIVE2, type RO, offset 0x308, reset 0x0000.0000															
INT															
INT															

31	30	29	28	27	26	25	24	23	22	21	20	19	18	17	16
15	14	13	12	11	10	9	8	7	6	5	4	3	2	1	0
ACTIVE3, type RO, offset 0x30C, reset 0x0000.0000															
INT															
INT															
ACTIVE4, type RO, offset 0x310, reset 0x0000.0000															
INT															
PRI0, type R/W, offset 0x400, reset 0x0000.0000															
INTD								INTC							
INTB								INTA							
PRI1, type R/W, offset 0x404, reset 0x0000.0000															
INTD								INTC							
INTB								INTA							
PRI2, type R/W, offset 0x408, reset 0x0000.0000															
INTD								INTC							
INTB								INTA							
PRI3, type R/W, offset 0x40C, reset 0x0000.0000															
INTD								INTC							
INTB								INTA							
PRI4, type R/W, offset 0x410, reset 0x0000.0000															
INTD								INTC							
INTB								INTA							
PRI5, type R/W, offset 0x414, reset 0x0000.0000															
INTD								INTC							
INTB								INTA							
PRI6, type R/W, offset 0x418, reset 0x0000.0000															
INTD								INTC							
INTB								INTA							
PRI7, type R/W, offset 0x41C, reset 0x0000.0000															
INTD								INTC							
INTB								INTA							
PRI8, type R/W, offset 0x420, reset 0x0000.0000															
INTD								INTC							
INTB								INTA							
PRI9, type R/W, offset 0x424, reset 0x0000.0000															
INTD								INTC							
INTB								INTA							
PRI10, type R/W, offset 0x428, reset 0x0000.0000															
INTD								INTC							
INTB								INTA							
PRI11, type R/W, offset 0x42C, reset 0x0000.0000															
INTD								INTC							
INTB								INTA							
PRI12, type R/W, offset 0x430, reset 0x0000.0000															
INTD								INTC							
INTB								INTA							
PRI13, type R/W, offset 0x434, reset 0x0000.0000															
INTD								INTC							
INTB								INTA							
PRI14, type R/W, offset 0x438, reset 0x0000.0000															
INTD								INTC							
INTB								INTA							

31	30	29	28	27	26	25	24	23	22	21	20	19	18	17	16												
15	14	13	12	11	10	9	8	7	6	5	4	3	2	1	0												
PRI32, type R/W, offset 0x480, reset 0x0000.0000																											
INTD								INTC																			
INTB								INTA																			
PRI33, type R/W, offset 0x484, reset 0x0000.0000																											
INTD								INTC																			
INTB								INTA																			
PRI34, type R/W, offset 0x488, reset 0x0000.0000																											
INTD								INTC																			
INTB								INTA																			
SWTRIG, type WO, offset 0xF00, reset 0x0000.0000																											
												INTID															
Cortex-M4 Peripherals																											
System Control Block (SCB) Registers																											
Base 0xE000.E000																											
ACTLR, type R/W, offset 0x008, reset 0x0000.0000																											
				DISOFP				DISFPCA								DISFOLD				DISWBUF		DISMCYC					
CPUID, type RO, offset 0xD00, reset 0x410F.C241																											
IMP				PARTNO				VAR				CON															
												REV															
INTCTRL, type R/W, offset 0xD04, reset 0x0000.0000																											
NMISSET				PENDSV		UNPENDSV		PENDTSET		PENDTCLR		ISRPRE		ISRPEND		VECPEND											
VECPEND				RETBASE						VECACT																	
VTABLE, type R/W, offset 0xD08, reset 0x0000.0000																											
BASE				OFFSET																							
OFFSET																											
APINT, type R/W, offset 0xD0C, reset 0xFA05.0000																											
VECTKEY																											
ENDIANESS				PRIGROUP								SYSRESREQ				VECTLRRACT		VECTRESET									
SYSCTRL, type R/W, offset 0xD10, reset 0x0000.0000																											
												SEVONPEND		SLEEPDEEP		SLEEPEXIT											
CFGCTRL, type R/W, offset 0xD14, reset 0x0000.0200																											
				STKALIGN				BFHFNMIGN				DIV0				UNALIGNED		MAINPEND		BASETHR							
SYSPRI1, type R/W, offset 0xD18, reset 0x0000.0000																											
BUS								USAGE				MEM															
SYSPRI2, type R/W, offset 0xD1C, reset 0x0000.0000																											
SVC																											
SYSPRI3, type R/W, offset 0xD20, reset 0x0000.0000																											
TICK								PENDSV				DEBUG															
SYSHNDCTRL, type R/W, offset 0xD24, reset 0x0000.0000																											
SVC		BUSP		MEMP		USAGEP		TICK		PNDSV		MON		SVCA		USGA		USAGE		BUS		MEM					
																		BUSA		MEMA							
FAULTSTAT, type R/W1C, offset 0xD28, reset 0x0000.0000																											
BFARV		BLSPERR		BSTKE		BUSTKE		IMPRE		PRECISE		IBUS		MMARV		MLSPERR		MSTKE		NOCP		INVPC		INVSTAT		UNDEF	
																				MUSTKE		DERR		IERR			

31	30	29	28	27	26	25	24	23	22	21	20	19	18	17	16		
15	14	13	12	11	10	9	8	7	6	5	4	3	2	1	0		
HFAULTSTAT, type R/W1C, offset 0xD2C, reset 0x0000.0000																	
DBG		FORCED												VECT			
MMADDR, type R/W, offset 0xD34, reset -																	
												ADDR					
												ADDR					
FAULTADDR, type R/W, offset 0xD38, reset -																	
												ADDR					
												ADDR					
Cortex-M4 Peripherals																	
Memory Protection Unit (MPU) Registers																	
Base 0xE000.E000																	
MPUTYPE, type RO, offset 0xD90, reset 0x0000.0800																	
								IREGION									
DREGION								SEPARATE									
MPUCTRL, type R/W, offset 0xD94, reset 0x0000.0000																	
												PRIVDEFEN		HFNMIENA		ENABLE	
MPUNUMBER, type R/W, offset 0xD98, reset 0x0000.0000																	
												NUMBER					
MPUBASE, type R/W, offset 0xD9C, reset 0x0000.0000																	
												ADDR					
ADDR												VALID		REGION			
MPUBASE1, type R/W, offset 0xDA4, reset 0x0000.0000																	
												ADDR					
ADDR												VALID		REGION			
MPUBASE2, type R/W, offset 0xDAC, reset 0x0000.0000																	
												ADDR					
ADDR												VALID		REGION			
MPUBASE3, type R/W, offset 0xDB4, reset 0x0000.0000																	
												ADDR					
ADDR												VALID		REGION			
MPUATTR, type R/W, offset 0xDA0, reset 0x0000.0000																	
				XN		AP		TEX				S		C		B	
SRD								SIZE				ENABLE					
MPUATTR1, type R/W, offset 0xDA8, reset 0x0000.0000																	
				XN		AP		TEX				S		C		B	
SRD								SIZE				ENABLE					
MPUATTR2, type R/W, offset 0xDB0, reset 0x0000.0000																	
				XN		AP		TEX				S		C		B	
SRD								SIZE				ENABLE					
MPUATTR3, type R/W, offset 0xDB8, reset 0x0000.0000																	
				XN		AP		TEX				S		C		B	
SRD								SIZE				ENABLE					
Cortex-M4 Peripherals																	
Floating-Point Unit (FPU) Registers																	
Base 0xE000.E000																	
CPAC, type R/W, offset 0xD88, reset 0x0000.0000																	
								CP11		CP10							

31	30	29	28	27	26	25	24	23	22	21	20	19	18	17	16												
15	14	13	12	11	10	9	8	7	6	5	4	3	2	1	0												
FPCC, type R/W, offset 0xF34, reset 0xC000.0000																											
ASPEN		LSPEN						MONRDY		BFRDY		MMRDY		HFRDY		THREAD		USER		LSPACT							
FPCA, type R/W, offset 0xF38, reset -																											
ADDRESS																											
ADDRESS																											
FPDSC, type R/W, offset 0xF3C, reset 0x0000.0000																											
				AHP		DN		FZ		RMODE																	
System Control																											
System Control Registers																											
Base 0x400F.E000																											
DID0, type RO, offset 0x000, reset -																											
				VER								CLASS															
				MAJOR								MINOR															
DID1, type RO, offset 0x004, reset -																											
				VER				FAM				PARTNO															
PINCOUNT								TEMP				PKG		ROHS		QUAL											
PBORCTL, type R/W, offset 0x030, reset 0x0000.0000																											
														BORIOR													
RIS, type RO, offset 0x050, reset 0x0000.0000																											
								MOSCPUPRIS		USBPLLRIS		PLLRIS				MOFRIS		BORRIS									
IMC, type R/W, offset 0x054, reset 0x0000.0000																											
								MOSCPUPIM		USBPLLLIM		PLLLIM				MOFIM		BORIM									
MISC, type R/W1C, offset 0x058, reset 0x0000.0000																											
								MOSCPUPMS		USBPLLLMIS		PLLLMIS				MOFMIS		BORMIS									
RESC, type R/W, offset 0x05C, reset -																											
														WDT1		SW		WDT0		BOR		POR		EXT		MOSCFAIL	
RCC, type R/W, offset 0x060, reset 0x078E.3D51																											
				ACG		SYSDIV				USESYSIV		USEPWMDIV		PWMDIV													
PWRDN		BYPASS		XTAL				OSCSRC						IOSCDIS		MOSCDIS											
GPIOHCTL, type R/W, offset 0x06C, reset 0x0000.7E00																											
								PORTG		PORTF		PORTE		PORTD		PORTC		PORTB		PORTA							
RCC2, type R/W, offset 0x070, reset 0x07C0.6810																											
USERCC2		DIV400		SYSDIV2				SYSDIV2LSB																			
USBPWRDN		PWRDN2		BYPASS2						OSCSRC2																	
MOSCCTL, type R/W, offset 0x07C, reset 0x0000.0000																											
														NOXTAL		MOSCIM		CVAL									
DSLCLKCFG, type R/W, offset 0x144, reset 0x0780.0000																											
								DSDIVORIDE																			
												DSOSCSRC															
SYSPPROP, type RO, offset 0x14C, reset 0x0000.1D31																											
														FPU													

31	30	29	28	27	26	25	24	23	22	21	20	19	18	17	16		
15	14	13	12	11	10	9	8	7	6	5	4	3	2	1	0		
PIOSCCAL, type R/W, offset 0x150, reset 0x0000.0000																	
UTEN				UPDATE				UT									
PLLREQ0, type RO, offset 0x160, reset 0x0000.0032																	
MFRAC				MINT				MFRAC									
PLLREQ1, type RO, offset 0x164, reset 0x0000.0001																	
				Q								N					
PLLSTAT, type RO, offset 0x168, reset 0x0000.0000																	
															LOCK		
PPWD, type RO, offset 0x300, reset 0x0000.0003																	
														P1	P0		
PPTIMER, type RO, offset 0x304, reset 0x0000.003F																	
										P5	P4	P3	P2	P1	P0		
PPGPIO, type RO, offset 0x308, reset 0x0000.007F																	
		P14	P13	P12	P11	P10	P9	P8	P7	P6	P5	P4	P3	P2	P1	P0	
PPDMA, type RO, offset 0x30C, reset 0x0000.0001																	
															P0		
PPHIB, type RO, offset 0x314, reset 0x0000.0000																	
															P0		
PPUART, type RO, offset 0x318, reset 0x0000.00FF																	
										P7	P6	P5	P4	P3	P2	P1	P0
PPSSI, type RO, offset 0x31C, reset 0x0000.000F																	
												P3	P2	P1	P0		
PPI2C, type RO, offset 0x320, reset 0x0000.003F																	
										P5	P4	P3	P2	P1	P0		
PPUSB, type RO, offset 0x328, reset 0x0000.0001																	
															P0		
PPCAN, type RO, offset 0x334, reset 0x0000.0003																	
														P1	P0		
PPADC, type RO, offset 0x338, reset 0x0000.0003																	
														P1	P0		
PPACMP, type RO, offset 0x33C, reset 0x0000.0001																	
															P0		
PPPWM, type RO, offset 0x340, reset 0x0000.0003																	
														P1	P0		

31	30	29	28	27	26	25	24	23	22	21	20	19	18	17	16		
15	14	13	12	11	10	9	8	7	6	5	4	3	2	1	0		
PPQEI, type RO, offset 0x344, reset 0x0000.0003																	
														P1	P0		
PPEEPROM, type RO, offset 0x358, reset 0x0000.0001																	
															P0		
PPWTIMER, type RO, offset 0x35C, reset 0x0000.003F																	
										P5	P4	P3	P2	P1	P0		
SRWD, type R/W, offset 0x500, reset 0x0000.0000																	
														R1	R0		
SRTIMER, type R/W, offset 0x504, reset 0x0000.0000																	
										R5	R4	R3	R2	R1	R0		
SRGPIO, type R/W, offset 0x508, reset 0x0000.0000																	
										R6	R5	R4	R3	R2	R1	R0	
SRDMA, type R/W, offset 0x50C, reset 0x0000.0000																	
															R0		
SRUART, type R/W, offset 0x518, reset 0x0000.0000																	
										R7	R6	R5	R4	R3	R2	R1	R0
SRSSI, type R/W, offset 0x51C, reset 0x0000.0000																	
													R3	R2	R1	R0	
SRIZC, type R/W, offset 0x520, reset 0x0000.0000																	
										R5	R4	R3	R2	R1	R0		
SRUSB, type R/W, offset 0x528, reset 0x0000.0000																	
																	R0
SRCAN, type R/W, offset 0x534, reset 0x0000.0000																	
																R1	R0
SRADC, type R/W, offset 0x538, reset 0x0000.0000																	
																R1	R0
SRACMP, type R/W, offset 0x53C, reset 0x0000.0000																	
																	R0
SRPWM, type R/W, offset 0x540, reset 0x0000.0000																	
																R1	R0
SRQEI, type R/W, offset 0x544, reset 0x0000.0000																	
																R1	R0
SREEPROM, type R/W, offset 0x558, reset 0x0000.0000																	
																	R0

31	30	29	28	27	26	25	24	23	22	21	20	19	18	17	16	
15	14	13	12	11	10	9	8	7	6	5	4	3	2	1	0	
SRWTIMER, type R/W, offset 0x55C, reset 0x0000.0000																
											R5	R4	R3	R2	R1	R0
RCGCWD, type R/W, offset 0x600, reset 0x0000.0000																
															R1	R0
RCGCTIMER, type R/W, offset 0x604, reset 0x0000.0000																
											R5	R4	R3	R2	R1	R0
RCGCGPIO, type R/W, offset 0x608, reset 0x0000.0000																
									R6	R5	R4	R3	R2	R1	R0	
RCGCDMA, type R/W, offset 0x60C, reset 0x0000.0000																
																R0
RCGCUART, type R/W, offset 0x618, reset 0x0000.0000																
								R7	R6	R5	R4	R3	R2	R1	R0	
RCGCSSI, type R/W, offset 0x61C, reset 0x0000.0000																
												R3	R2	R1	R0	
RCGCI2C, type R/W, offset 0x620, reset 0x0000.0000																
										R5	R4	R3	R2	R1	R0	
RCGCUSB, type R/W, offset 0x628, reset 0x0000.0000																
																R0
RCGCCAN, type R/W, offset 0x634, reset 0x0000.0000																
															R1	R0
RCGCADC, type R/W, offset 0x638, reset 0x0000.0000																
															R1	R0
RCGCACMP, type R/W, offset 0x63C, reset 0x0000.0000																
																R0
RCGCPWM, type R/W, offset 0x640, reset 0x0000.0000																
															R1	R0
RCGCQEI, type R/W, offset 0x644, reset 0x0000.0000																
															R1	R0
RCGCEEPROM, type R/W, offset 0x658, reset 0x0000.0000																
																R0
RCGCWTIMER, type R/W, offset 0x65C, reset 0x0000.0000																
											R5	R4	R3	R2	R1	R0
SCGCWD, type R/W, offset 0x700, reset 0x0000.0000																
															S1	S0

31	30	29	28	27	26	25	24	23	22	21	20	19	18	17	16	
15	14	13	12	11	10	9	8	7	6	5	4	3	2	1	0	
SCGCTIMER, type R/W, offset 0x704, reset 0x0000.0000																
										S5	S4	S3	S2	S1	S0	
SCGCGPIO, type R/W, offset 0x708, reset 0x0000.0000																
									S6	S5	S4	S3	S2	S1	S0	
SCGCDMA, type R/W, offset 0x70C, reset 0x0000.0000																
															S0	
SCGCUART, type R/W, offset 0x718, reset 0x0000.0000																
								S7	S6	S5	S4	S3	S2	S1	S0	
SCGCSSI, type R/W, offset 0x71C, reset 0x0000.0000																
												S3	S2	S1	S0	
SCGC12C, type R/W, offset 0x720, reset 0x0000.0000																
										S5	S4	S3	S2	S1	S0	
SCGCUSB, type R/W, offset 0x728, reset 0x0000.0000																
															S0	
SCGCCAN, type R/W, offset 0x734, reset 0x0000.0000																
														S1	S0	
SCGCADC, type R/W, offset 0x738, reset 0x0000.0000																
														S1	S0	
SCGCACMP, type R/W, offset 0x73C, reset 0x0000.0000																
															S0	
SCGCPWM, type R/W, offset 0x740, reset 0x0000.0000																
														S1	S0	
SCGCQEI, type R/W, offset 0x744, reset 0x0000.0000																
														S1	S0	
SCGCEEPROM, type R/W, offset 0x758, reset 0x0000.0000																
															S0	
SCGCWTIMER, type R/W, offset 0x75C, reset 0x0000.0000																
										S5	S4	S3	S2	S1	S0	
DCGCWD, type R/W, offset 0x800, reset 0x0000.0000																
														D1	D0	
DCGCTIMER, type R/W, offset 0x804, reset 0x0000.0000																
										D5	D4	D3	D2	D1	D0	
DCGCGPIO, type R/W, offset 0x808, reset 0x0000.0000																
										D6	D5	D4	D3	D2	D1	D0

31	30	29	28	27	26	25	24	23	22	21	20	19	18	17	16		
15	14	13	12	11	10	9	8	7	6	5	4	3	2	1	0		
DCGCDMA, type R/W, offset 0x80C, reset 0x0000.0000																	
															D0		
DCGCUART, type R/W, offset 0x818, reset 0x0000.0000																	
								D7	D6	D5	D4	D3	D2	D1	D0		
DCGCSSI, type R/W, offset 0x81C, reset 0x0000.0000																	
												D3	D2	D1	D0		
DCGCI2C, type R/W, offset 0x820, reset 0x0000.0000																	
										D5	D4	D3	D2	D1	D0		
DCGCUSB, type R/W, offset 0x828, reset 0x0000.0000																	
															D0		
DCGCCAN, type R/W, offset 0x834, reset 0x0000.0000																	
														D1	D0		
DCGCADC, type R/W, offset 0x838, reset 0x0000.0000																	
														D1	D0		
DCGCACMP, type R/W, offset 0x83C, reset 0x0000.0000																	
															D0		
DCGCPWM, type R/W, offset 0x840, reset 0x0000.0000																	
														D1	D0		
DCGCQEI, type R/W, offset 0x844, reset 0x0000.0000																	
														D1	D0		
DCGCEEPROM, type R/W, offset 0x858, reset 0x0000.0000																	
															D0		
DCGCWTIMER, type R/W, offset 0x85C, reset 0x0000.0000																	
										D5	D4	D3	D2	D1	D0		
PCWD, type R/W, offset 0x900, reset 0x0000.0003																	
														P1	P0		
PCTIMER, type R/W, offset 0x904, reset 0x0000.003F																	
										P5	P4	P3	P2	P1	P0		
PCGPIO, type R/W, offset 0x908, reset 0x0000.7FFF																	
										P6	P5	P4	P3	P2	P1	P0	
PCDMA, type R/W, offset 0x90C, reset 0x0000.0001																	
															P0		
PCUART, type R/W, offset 0x918, reset 0x0000.00FF																	
										P7	P6	P5	P4	P3	P2	P1	P0

31	30	29	28	27	26	25	24	23	22	21	20	19	18	17	16		
15	14	13	12	11	10	9	8	7	6	5	4	3	2	1	0		
PCSSI, type R/W, offset 0x91C, reset 0x0000.000F																	
													P3	P2	P1	P0	
PCI2C, type R/W, offset 0x920, reset 0x0000.003F																	
										P5	P4	P3	P2	P1	P0		
PCUSB, type R/W, offset 0x928, reset 0x0000.0001																	
																P0	
PCCAN, type R/W, offset 0x934, reset 0x0000.0003																	
															P1	P0	
PCADC, type R/W, offset 0x938, reset 0x0000.0003																	
															P1	P0	
PCACMP, type R/W, offset 0x93C, reset 0x0000.0001																	
																P0	
PCPWM, type R/W, offset 0x940, reset 0x0000.0003																	
															P1	P0	
PCQEI, type R/W, offset 0x944, reset 0x0000.0003																	
															P1	P0	
PCEEPROM, type R/W, offset 0x958, reset 0x0000.0001																	
																P0	
PCWTIMER, type R/W, offset 0x95C, reset 0x0000.0000																	
										P5	P4	P3	P2	P1	P0		
PRWD, type R/W, offset 0xA00, reset 0x0000.0000																	
															R1	R0	
PRTIMER, type R/W, offset 0xA04, reset 0x0000.0000																	
										R5	R4	R3	R2	R1	R0		
PRGPIO, type R/W, offset 0xA08, reset 0x0000.0000																	
										R6	R5	R4	R3	R2	R1	R0	
PRDMA, type R/W, offset 0xA0C, reset 0x0000.0000																	
																R0	
PRUART, type R/W, offset 0xA18, reset 0x0000.0000																	
										R7	R6	R5	R4	R3	R2	R1	R0
PRSSI, type R/W, offset 0xA1C, reset 0x0000.0000																	
													R3	R2	R1	R0	
PRI2C, type R/W, offset 0xA20, reset 0x0000.0000																	
										R5	R4	R3	R2	R1	R0		

31	30	29	28	27	26	25	24	23	22	21	20	19	18	17	16			
15	14	13	12	11	10	9	8	7	6	5	4	3	2	1	0			
PRUSB, type R/W, offset 0xA28, reset 0x0000.0000																		
															R0			
PRCAN, type R/W, offset 0xA34, reset 0x0000.0000																		
														R1	R0			
PRADC, type R/W, offset 0xA38, reset 0x0000.0000																		
														R1	R0			
PRACMP, type R/W, offset 0xA3C, reset 0x0000.0000																		
															R0			
PRPWM, type R/W, offset 0xA40, reset 0x0000.0000																		
														R1	R0			
PRQEI, type R/W, offset 0xA44, reset 0x0000.0000																		
														R1	R0			
PREEPROM, type R/W, offset 0xA58, reset 0x0000.0000																		
															R0			
PRWTIMER, type R/W, offset 0xA5C, reset 0x0000.0000																		
											R5	R4	R3	R2	R1	R0		
System Control																		
System Control Legacy Registers																		
Base 0x400F.E000																		
DC0, type RO, offset 0x008, reset 0x007F.007F																		
SRAMSZ																		
FLASHSZ																		
DC1, type RO, offset 0x010, reset 0x1333.2FBF																		
				WDT1					CAN1	CAN0			PWM1	PWM0			ADC1	ADC0
MINSYSDIV				MAXADC1SPD				MAXADC0SPD		MPU	HIB	TEMPSNS	PLL	WDT0	SWO	SWD	JTAG	
DC2, type RO, offset 0x014, reset 0x030F.F337																		
		EPI0	I2S0		COMP2		COMP1	COMP0				TIMER3	TIMER2	TIMER1	TIMER0			
I2C1HS	I2C1	I2C0HS	I2C0			QE1	QE0				SSI1	SSI0	UART2	UART1	UART0			
DC3, type RO, offset 0x018, reset 0xBFFF.8FFF																		
32KHZ	CCP5		CCP4	CCP3	CCP2	CCP1	CCP0	ADC0AIN7	ADC0AIN6	ADC0AIN5	ADC0AIN4	ADC0AIN3	ADC0AIN2	ADC0AIN1	ADC0AIN0			
PWMFAULT	C20	C2PLUS	C2MINUS	C10	C1PLUS	C1MINUS	C00	C0PLUS	C0MINUS	PWM5	PWM4	PWM3	PWM2	PWM1	PWM0			
DC4, type RO, offset 0x01C, reset 0x0004.F07F																		
EPHY0		EMAC0						E1588					PICAL					
CCP7	CCP6	UDMA	ROM					GPI0J	GPI0H	GPI0G	GPI0F	GPI0E	GPI0D	GPI0C	GPI0B	GPI0A		
DC5, type RO, offset 0x020, reset 0x0730.00FF																		
				PWMFAULT3	PWMFAULT2	PWMFAULT1	PWMFAULT0				PWMEFLT	PWME SYNC						
								PWM7	PWM6	PWM5	PWM4	PWM3	PWM2	PWM1	PWM0			
DC6, type RO, offset 0x024, reset 0x0000.0013																		
															USB0PHY	USB0		
DC7, type RO, offset 0x028, reset 0xFFFF.FFFF																		
		DMACH30	DMACH29	DMACH28	DMACH27	DMACH26	DMACH25	DMACH24	DMACH23	DMACH22	DMACH21	DMACH20	DMACH19	DMACH18	DMACH17	DMACH16		
DMACH15	DMACH14	DMACH13	DMACH12	DMACH11	DMACH10	DMACH9	DMACH8	DMACH7	DMACH6	DMACH5	DMACH4	DMACH3	DMACH2	DMACH1	DMACH0			

31	30	29	28	27	26	25	24	23	22	21	20	19	18	17	16
15	14	13	12	11	10	9	8	7	6	5	4	3	2	1	0
DC8, type RO, offset 0x02C, reset 0x0FFF.0FFF															
ADC1AIN15	ADC1AIN14	ADC1AIN13	ADC1AIN12	ADC1AIN11	ADC1AIN10	ADC1AIN9	ADC1AIN8	ADC1AIN7	ADC1AIN6	ADC1AIN5	ADC1AIN4	ADC1AIN3	ADC1AIN2	ADC1AIN1	ADC1AIN0
ADC0AIN15	ADC0AIN14	ADC0AIN13	ADC0AIN12	ADC0AIN11	ADC0AIN10	ADC0AIN9	ADC0AIN8	ADC0AIN7	ADC0AIN6	ADC0AIN5	ADC0AIN4	ADC0AIN3	ADC0AIN2	ADC0AIN1	ADC0AIN0
SRCR0, type RO, offset 0x040, reset 0x0000.0000															
			WDT1			CAN1	CAN0				PWM0			ADC1	ADC0
												WDT0			
SRCR1, type RO, offset 0x044, reset 0x0000.0000															
						COMP1	COMP0					TIMER3	TIMER2	TIMER1	TIMER0
	I2C1		I2C0			QE1	QE10				SSI1	SSI0	UART2	UART1	UART0
SRCR2, type RO, offset 0x048, reset 0x0000.0000															
															USB0
		UDMA							GPIOG	GPIOF	GPIOE	GPIOD	GPIOC	GPIOB	GPIOA
RCGC0, type RO, offset 0x100, reset 0x0000.0040															
			WDT1			CAN1	CAN0				PWM0			ADC1	ADC0
					MAXADC1SPD	MAXADC0SPD						WDT0			
RCGC1, type RO, offset 0x104, reset 0x0000.0000															
						COMP1	COMP0					TIMER3	TIMER2	TIMER1	TIMER0
	I2C1		I2C0			QE1	QE10				SSI1	SSI0	UART2	UART1	UART0
RCGC2, type RO, offset 0x108, reset 0x0000.0000															
															USB0
		UDMA							GPIOG	GPIOF	GPIOE	GPIOD	GPIOC	GPIOB	GPIOA
SCGC0, type RO, offset 0x110, reset 0x0000.0040															
			WDT1			CAN1	CAN0				PWM0			ADC1	ADC0
												WDT0			
SCGC1, type RO, offset 0x114, reset 0x0000.0000															
						COMP1	COMP0					TIMER3	TIMER2	TIMER1	TIMER0
	I2C1		I2C0			QE1	QE10				SSI1	SSI0	UART2	UART1	UART0
SCGC2, type RO, offset 0x118, reset 0x0000.0000															
															USB0
		UDMA							GPIOG	GPIOF	GPIOE	GPIOD	GPIOC	GPIOB	GPIOA
DCGC0, type RO, offset 0x120, reset 0x0000.0040															
			WDT1			CAN1	CAN0				PWM0			ADC1	ADC0
												WDT0			
DCGC1, type RO, offset 0x124, reset 0x0000.0000															
						COMP1	COMP0					TIMER3	TIMER2	TIMER1	TIMER0
	I2C1		I2C0			QE1	QE10				SSI1	SSI0	UART2	UART1	UART0
DCGC2, type RO, offset 0x128, reset 0x0000.0000															
															USB0
		UDMA							GPIOG	GPIOF	GPIOE	GPIOD	GPIOC	GPIOB	GPIOA
DC9, type RO, offset 0x190, reset 0x00FF.00FF															
								ADC1DC7	ADC1DC6	ADC1DC5	ADC1DC4	ADC1DC3	ADC1DC2	ADC1DC1	ADC1DC0
								ADC0DC7	ADC0DC6	ADC0DC5	ADC0DC4	ADC0DC3	ADC0DC2	ADC0DC1	ADC0DC0
NVMSTAT, type RO, offset 0x1A0, reset 0x0000.0001															
															FWB
System Exception Module															
Base 0x400F.9000															
SYSEXCRI, type RO, offset 0x000, reset 0x0000.0000 (see page 494)															
										FPIXCRIS	FPOFCRIS	FPUFCRIS	FPIOCRIS	FPDZCRIS	FPIDCRIS
SYSEXCIM, type R/W, offset 0x004, reset 0x0000.0000 (see page 496)															
										FPIXCIM	FPOFCIM	FPUFCIM	FPIOCIM	FPDZCIM	FPIDCIM

31	30	29	28	27	26	25	24	23	22	21	20	19	18	17	16																																																							
15	14	13	12	11	10	9	8	7	6	5	4	3	2	1	0																																																							
SYSEXCMIS, type RO, offset 0x008, reset 0x0000.0000 (see page 498)																																																																						
<table border="1" style="width:100%; border-collapse: collapse;"> <tr> <td style="width:40%;"></td> <td style="width:40%;"></td> <td style="width:10%;"></td> <td style="width:10%;"></td> <td style="width:10%;"></td> <td style="width:10%;"></td> <td style="width:10%;"></td> <td style="width:10%;"></td> <td style="width:10%;"></td> <td style="width:10%;"></td> <td style="width:10%;"></td> <td style="width:10%;"></td> <td style="width:10%;"></td> <td style="width:10%;"></td> <td style="width:10%;"></td> <td style="width:10%;"></td> </tr> <tr> <td></td><td></td><td></td><td></td><td></td><td></td><td></td><td></td><td></td><td></td><td></td><td></td><td>FPIXCMIS</td><td>FPOFCMIS</td><td>FPUFCMIS</td><td>FPIOCMIS</td><td>FPDZCMIS</td><td>FPIDCMIS</td> </tr> </table>																																												FPIXCMIS	FPOFCMIS	FPUFCMIS	FPIOCMIS	FPDZCMIS	FPIDCMIS																					
												FPIXCMIS	FPOFCMIS	FPUFCMIS	FPIOCMIS	FPDZCMIS	FPIDCMIS																																																					
SYSEXCIC, type W1C, offset 0x00C, reset 0x0000.0000 (see page 500)																																																																						
<table border="1" style="width:100%; border-collapse: collapse;"> <tr> <td style="width:40%;"></td> <td style="width:40%;"></td> <td style="width:10%;"></td> <td style="width:10%;"></td> <td style="width:10%;"></td> <td style="width:10%;"></td> <td style="width:10%;"></td> <td style="width:10%;"></td> <td style="width:10%;"></td> <td style="width:10%;"></td> <td style="width:10%;"></td> <td style="width:10%;"></td> <td style="width:10%;"></td> <td style="width:10%;"></td> <td style="width:10%;"></td> <td style="width:10%;"></td> <td style="width:10%;"></td> </tr> <tr> <td></td><td></td><td></td><td></td><td></td><td></td><td></td><td></td><td></td><td></td><td></td><td></td><td>FPIXCIC</td><td>FPOFCIC</td><td>FPUFCIC</td><td>FPIOCIC</td><td>FPDZCIC</td><td>FPIDCIC</td> </tr> </table>																																													FPIXCIC	FPOFCIC	FPUFCIC	FPIOCIC	FPDZCIC	FPIDCIC																				
												FPIXCIC	FPOFCIC	FPUFCIC	FPIOCIC	FPDZCIC	FPIDCIC																																																					
Internal Memory																																																																						
Flash Memory Registers (Flash Control Offset)																																																																						
Base 0x400F.D000																																																																						
FMA, type R/W, offset 0x000, reset 0x0000.0000																																																																						
<table border="1" style="width:100%; border-collapse: collapse;"> <tr> <td style="width:40%;"></td> <td style="width:40%;"></td> <td style="width:10%;"></td> <td style="width:10%;"></td> <td style="width:10%;"></td> <td style="width:10%;"></td> <td style="width:10%;"></td> <td style="width:10%;"></td> <td style="width:10%;"></td> <td style="width:10%;"></td> <td style="width:10%;"></td> <td style="width:10%;"></td> <td style="width:10%;"></td> <td style="width:10%;"></td> <td style="width:10%;"></td> <td style="width:10%;"></td> <td style="width:10%;"></td> </tr> <tr> <td></td><td></td><td></td><td></td><td></td><td></td><td></td><td></td><td></td><td></td><td></td><td></td><td></td><td></td><td></td><td></td><td></td><td>OFFSET</td> </tr> </table>																																																		OFFSET																				
																	OFFSET																																																					
FMD, type R/W, offset 0x004, reset 0x0000.0000																																																																						
<table border="1" style="width:100%; border-collapse: collapse;"> <tr> <td style="width:40%;"></td> <td style="width:40%;"></td> <td style="width:10%;"></td> <td style="width:10%;"></td> <td style="width:10%;"></td> <td style="width:10%;"></td> <td style="width:10%;"></td> <td style="width:10%;"></td> <td style="width:10%;"></td> <td style="width:10%;"></td> <td style="width:10%;"></td> <td style="width:10%;"></td> <td style="width:10%;"></td> <td style="width:10%;"></td> <td style="width:10%;"></td> <td style="width:10%;"></td> <td style="width:10%;"></td> </tr> <tr> <td></td><td></td><td></td><td></td><td></td><td></td><td></td><td></td><td></td><td></td><td></td><td></td><td></td><td></td><td></td><td></td><td></td><td>DATA</td> </tr> <tr> <td></td><td></td><td></td><td></td><td></td><td></td><td></td><td></td><td></td><td></td><td></td><td></td><td></td><td></td><td></td><td></td><td></td><td>DATA</td> </tr> </table>																																																		DATA																		DATA		
																	DATA																																																					
																	DATA																																																					
FMC, type R/W, offset 0x008, reset 0x0000.0000																																																																						
<table border="1" style="width:100%; border-collapse: collapse;"> <tr> <td style="width:40%;"></td> <td style="width:40%;"></td> <td style="width:10%;"></td> <td style="width:10%;"></td> <td style="width:10%;"></td> <td style="width:10%;"></td> <td style="width:10%;"></td> <td style="width:10%;"></td> <td style="width:10%;"></td> <td style="width:10%;"></td> <td style="width:10%;"></td> <td style="width:10%;"></td> <td style="width:10%;"></td> <td style="width:10%;"></td> <td style="width:10%;"></td> <td style="width:10%;"></td> <td style="width:10%;"></td> </tr> <tr> <td></td><td></td><td></td><td></td><td></td><td></td><td></td><td></td><td></td><td></td><td></td><td></td><td></td><td></td><td></td><td></td><td></td><td>WRKEY</td> </tr> <tr> <td></td><td></td><td></td><td></td><td></td><td></td><td></td><td></td><td></td><td></td><td></td><td></td><td></td><td></td><td></td><td></td><td>COMT</td><td>MERASE</td><td>ERASE</td><td>WRITE</td> </tr> </table>																																																		WRKEY																	COMT	MERASE	ERASE	WRITE
																	WRKEY																																																					
																COMT	MERASE	ERASE	WRITE																																																			
FCRIS, type RO, offset 0x00C, reset 0x0000.0000																																																																						
<table border="1" style="width:100%; border-collapse: collapse;"> <tr> <td style="width:40%;"></td> <td style="width:40%;"></td> <td style="width:10%;"></td> <td style="width:10%;"></td> <td style="width:10%;"></td> <td style="width:10%;"></td> <td style="width:10%;"></td> <td style="width:10%;"></td> <td style="width:10%;"></td> <td style="width:10%;"></td> <td style="width:10%;"></td> <td style="width:10%;"></td> <td style="width:10%;"></td> <td style="width:10%;"></td> <td style="width:10%;"></td> <td style="width:10%;"></td> <td style="width:10%;"></td> </tr> <tr> <td></td><td></td><td></td><td>PROGRIS</td><td></td><td>ERRIS</td><td>INVDRIS</td><td>VOLTRIS</td><td></td><td></td><td></td><td></td><td></td><td></td><td></td><td>ERIS</td><td>PRIS</td><td>ARIS</td> </tr> </table>																																				PROGRIS		ERRIS	INVDRIS	VOLTRIS								ERIS	PRIS	ARIS																				
			PROGRIS		ERRIS	INVDRIS	VOLTRIS								ERIS	PRIS	ARIS																																																					
FCIM, type R/W, offset 0x010, reset 0x0000.0000																																																																						
<table border="1" style="width:100%; border-collapse: collapse;"> <tr> <td style="width:40%;"></td> <td style="width:40%;"></td> <td style="width:10%;"></td> <td style="width:10%;"></td> <td style="width:10%;"></td> <td style="width:10%;"></td> <td style="width:10%;"></td> <td style="width:10%;"></td> <td style="width:10%;"></td> <td style="width:10%;"></td> <td style="width:10%;"></td> <td style="width:10%;"></td> <td style="width:10%;"></td> <td style="width:10%;"></td> <td style="width:10%;"></td> <td style="width:10%;"></td> <td style="width:10%;"></td> </tr> <tr> <td></td><td></td><td></td><td>PROGMASK</td><td></td><td>ERMASK</td><td>INVDMASK</td><td>VOLTMASK</td><td></td><td></td><td></td><td></td><td></td><td></td><td></td><td>EMASK</td><td>PMASK</td><td>AMASK</td> </tr> </table>																																				PROGMASK		ERMASK	INVDMASK	VOLTMASK								EMASK	PMASK	AMASK																				
			PROGMASK		ERMASK	INVDMASK	VOLTMASK								EMASK	PMASK	AMASK																																																					
FCMISC, type R/W1C, offset 0x014, reset 0x0000.0000																																																																						
<table border="1" style="width:100%; border-collapse: collapse;"> <tr> <td style="width:40%;"></td> <td style="width:40%;"></td> <td style="width:10%;"></td> <td style="width:10%;"></td> <td style="width:10%;"></td> <td style="width:10%;"></td> <td style="width:10%;"></td> <td style="width:10%;"></td> <td style="width:10%;"></td> <td style="width:10%;"></td> <td style="width:10%;"></td> <td style="width:10%;"></td> <td style="width:10%;"></td> <td style="width:10%;"></td> <td style="width:10%;"></td> <td style="width:10%;"></td> <td style="width:10%;"></td> </tr> <tr> <td></td><td></td><td></td><td>PROGMISC</td><td></td><td>ERMISC</td><td>INVDMISC</td><td>VOLTMISC</td><td></td><td></td><td></td><td></td><td></td><td></td><td></td><td>EMISC</td><td>PMISC</td><td>AMISC</td> </tr> </table>																																				PROGMISC		ERMISC	INVDMISC	VOLTMISC								EMISC	PMISC	AMISC																				
			PROGMISC		ERMISC	INVDMISC	VOLTMISC								EMISC	PMISC	AMISC																																																					
FMC2, type R/W, offset 0x020, reset 0x0000.0000																																																																						
<table border="1" style="width:100%; border-collapse: collapse;"> <tr> <td style="width:40%;"></td> <td style="width:40%;"></td> <td style="width:10%;"></td> <td style="width:10%;"></td> <td style="width:10%;"></td> <td style="width:10%;"></td> <td style="width:10%;"></td> <td style="width:10%;"></td> <td style="width:10%;"></td> <td style="width:10%;"></td> <td style="width:10%;"></td> <td style="width:10%;"></td> <td style="width:10%;"></td> <td style="width:10%;"></td> <td style="width:10%;"></td> <td style="width:10%;"></td> <td style="width:10%;"></td> </tr> <tr> <td></td><td></td><td></td><td></td><td></td><td></td><td></td><td></td><td></td><td></td><td></td><td></td><td></td><td></td><td></td><td></td><td></td><td>WRKEY</td> </tr> <tr> <td></td><td></td><td></td><td></td><td></td><td></td><td></td><td></td><td></td><td></td><td></td><td></td><td></td><td></td><td></td><td></td><td></td><td>WRBUF</td> </tr> </table>																																																		WRKEY																		WRBUF		
																	WRKEY																																																					
																	WRBUF																																																					
FWBVAL, type R/W, offset 0x030, reset 0x0000.0000																																																																						
<table border="1" style="width:100%; border-collapse: collapse;"> <tr> <td style="width:40%;"></td> <td style="width:40%;"></td> <td style="width:10%;"></td> <td style="width:10%;"></td> <td style="width:10%;"></td> <td style="width:10%;"></td> <td style="width:10%;"></td> <td style="width:10%;"></td> <td style="width:10%;"></td> <td style="width:10%;"></td> <td style="width:10%;"></td> <td style="width:10%;"></td> <td style="width:10%;"></td> <td style="width:10%;"></td> <td style="width:10%;"></td> <td style="width:10%;"></td> <td style="width:10%;"></td> </tr> <tr> <td></td><td></td><td></td><td></td><td></td><td></td><td></td><td></td><td></td><td></td><td></td><td></td><td></td><td></td><td></td><td></td><td></td><td>FWB[n]</td> </tr> <tr> <td></td><td></td><td></td><td></td><td></td><td></td><td></td><td></td><td></td><td></td><td></td><td></td><td></td><td></td><td></td><td></td><td></td><td>FWB[n]</td> </tr> </table>																																																		FWB[n]																		FWB[n]		
																	FWB[n]																																																					
																	FWB[n]																																																					
FWBn, type R/W, offset 0x100 - 0x17C, reset 0x0000.0000																																																																						
<table border="1" style="width:100%; border-collapse: collapse;"> <tr> <td style="width:40%;"></td> <td style="width:40%;"></td> <td style="width:10%;"></td> <td style="width:10%;"></td> <td style="width:10%;"></td> <td style="width:10%;"></td> <td style="width:10%;"></td> <td style="width:10%;"></td> <td style="width:10%;"></td> <td style="width:10%;"></td> <td style="width:10%;"></td> <td style="width:10%;"></td> <td style="width:10%;"></td> <td style="width:10%;"></td> <td style="width:10%;"></td> <td style="width:10%;"></td> <td style="width:10%;"></td> </tr> <tr> <td></td><td></td><td></td><td></td><td></td><td></td><td></td><td></td><td></td><td></td><td></td><td></td><td></td><td></td><td></td><td></td><td></td><td>DATA</td> </tr> <tr> <td></td><td></td><td></td><td></td><td></td><td></td><td></td><td></td><td></td><td></td><td></td><td></td><td></td><td></td><td></td><td></td><td></td><td>DATA</td> </tr> </table>																																																		DATA																		DATA		
																	DATA																																																					
																	DATA																																																					
FSIZE, type RO, offset 0xFC0, reset 0x0000.007F																																																																						
<table border="1" style="width:100%; border-collapse: collapse;"> <tr> <td style="width:40%;"></td> <td style="width:40%;"></td> <td style="width:10%;"></td> <td style="width:10%;"></td> <td style="width:10%;"></td> <td style="width:10%;"></td> <td style="width:10%;"></td> <td style="width:10%;"></td> <td style="width:10%;"></td> <td style="width:10%;"></td> <td style="width:10%;"></td> <td style="width:10%;"></td> <td style="width:10%;"></td> <td style="width:10%;"></td> <td style="width:10%;"></td> <td style="width:10%;"></td> <td style="width:10%;"></td> </tr> <tr> <td></td><td></td><td></td><td></td><td></td><td></td><td></td><td></td><td></td><td></td><td></td><td></td><td></td><td></td><td></td><td></td><td></td><td>SIZE</td> </tr> </table>																																																		SIZE																				
																	SIZE																																																					
SSIZE, type RO, offset 0xFC4, reset 0x0000.007F																																																																						
<table border="1" style="width:100%; border-collapse: collapse;"> <tr> <td style="width:40%;"></td> <td style="width:40%;"></td> <td style="width:10%;"></td> <td style="width:10%;"></td> <td style="width:10%;"></td> <td style="width:10%;"></td> <td style="width:10%;"></td> <td style="width:10%;"></td> <td style="width:10%;"></td> <td style="width:10%;"></td> <td style="width:10%;"></td> <td style="width:10%;"></td> <td style="width:10%;"></td> <td style="width:10%;"></td> <td style="width:10%;"></td> <td style="width:10%;"></td> <td style="width:10%;"></td> </tr> <tr> <td></td><td></td><td></td><td></td><td></td><td></td><td></td><td></td><td></td><td></td><td></td><td></td><td></td><td></td><td></td><td></td><td></td><td>SIZE</td> </tr> </table>																																																		SIZE																				
																	SIZE																																																					
ROMSWMAP, type RO, offset 0xFCC, reset 0x0000.0000																																																																						
<table border="1" style="width:100%; border-collapse: collapse;"> <tr> <td style="width:40%;"></td> <td style="width:40%;"></td> <td style="width:10%;"></td> <td style="width:10%;"></td> <td style="width:10%;"></td> <td style="width:10%;"></td> <td style="width:10%;"></td> <td style="width:10%;"></td> <td style="width:10%;"></td> <td style="width:10%;"></td> <td style="width:10%;"></td> <td style="width:10%;"></td> <td style="width:10%;"></td> <td style="width:10%;"></td> <td style="width:10%;"></td> <td style="width:10%;"></td> <td style="width:10%;"></td> </tr> <tr> <td></td><td></td><td></td><td></td><td></td><td></td><td></td><td></td><td></td><td></td><td></td><td></td><td></td><td></td><td></td><td></td><td></td><td>SAFERTOS</td> </tr> </table>																																																		SAFERTOS																				
																	SAFERTOS																																																					
Internal Memory																																																																						
EEPROM Registers (EEPROM Control Offset)																																																																						
Base 0x400A.F000																																																																						
EESIZE, type RO, offset 0x000, reset 0x0020.0200																																																																						
<table border="1" style="width:100%; border-collapse: collapse;"> <tr> <td style="width:40%;"></td> <td style="width:40%;"></td> <td style="width:10%;"></td> <td style="width:10%;"></td> <td style="width:10%;"></td> <td style="width:10%;"></td> <td style="width:10%;"></td> <td style="width:10%;"></td> <td style="width:10%;"></td> <td style="width:10%;"></td> <td style="width:10%;"></td> <td style="width:10%;"></td> <td style="width:10%;"></td> <td style="width:10%;"></td> <td style="width:10%;"></td> <td style="width:10%;"></td> <td style="width:10%;"></td> </tr> <tr> <td></td><td></td><td></td><td></td><td></td><td></td><td></td><td></td><td></td><td></td><td></td><td></td><td></td><td></td><td></td><td></td><td></td><td>BLKCNT</td> </tr> <tr> <td></td><td></td><td></td><td></td><td></td><td></td><td></td><td></td><td></td><td></td><td></td><td></td><td></td><td></td><td></td><td></td><td></td><td>WORDCNT</td> </tr> </table>																																																		BLKCNT																		WORDCNT		
																	BLKCNT																																																					
																	WORDCNT																																																					

31	30	29	28	27	26	25	24	23	22	21	20	19	18	17	16
15	14	13	12	11	10	9	8	7	6	5	4	3	2	1	0
EEBLOCK, type R/W, offset 0x004, reset 0x0000.0000															
BLOCK															
EEOFFSET, type R/W, offset 0x008, reset 0x0000.0000															
OFFSET															
EERDWR, type R/W, offset 0x010, reset -															
VALUE															
VALUE															
EERDWRINC, type R/W, offset 0x014, reset -															
VALUE															
VALUE															
EEDONE, type RO, offset 0x018, reset 0x0000.0000															
INVPL WRBUSY NOPERM WKCOPY WKERASE WORKING															
EESUPP, type R/W, offset 0x01C, reset -															
PRETRY ERETRY EREQ START															
EEUNLOCK, type R/W, offset 0x020, reset -															
UNLOCK															
UNLOCK															
EEPROT, type R/W, offset 0x030, reset 0x0000.0000															
ACC PROT															
EEPASS0, type R/W, offset 0x034, reset -															
PASS															
PASS															
EEPASS1, type R/W, offset 0x038, reset -															
PASS															
PASS															
EEPASS2, type R/W, offset 0x03C, reset -															
PASS															
PASS															
EEINT, type R/W, offset 0x040, reset 0x0000.0000															
INT															
EEHIDE, type R/W, offset 0x050, reset 0x0000.0000															
Hn															
Hn															
EEDBGME, type R/W, offset 0x080, reset 0x0000.0000															
KEY															
ME															
EEPROMPP, type RO, offset 0xFC0, reset 0x0000.001F															
SIZE															
Internal Memory															
Memory Registers (System Control Offset)															
Base 0x400F.E000															
RMCTL, type R/W1C, offset 0x0F0, reset -															
BA															

31	30	29	28	27	26	25	24	23	22	21	20	19	18	17	16	
15	14	13	12	11	10	9	8	7	6	5	4	3	2	1	0	
FMPRE0, type R/W, offset 0x130 and 0x200, reset 0xFFFF.FFFF																
READ_ENABLE																
READ_ENABLE																
FMPRE1, type R/W, offset 0x204, reset 0xFFFF.FFFF																
READ_ENABLE																
READ_ENABLE																
FMPRE2, type R/W, offset 0x208, reset 0xFFFF.FFFF																
READ_ENABLE																
READ_ENABLE																
FMPRE3, type R/W, offset 0x20C, reset 0xFFFF.FFFF																
READ_ENABLE																
READ_ENABLE																
FMPPE0, type R/W, offset 0x134 and 0x400, reset 0xFFFF.FFFF																
PROG_ENABLE																
PROG_ENABLE																
FMPPE1, type R/W, offset 0x404, reset 0xFFFF.FFFF																
PROG_ENABLE																
PROG_ENABLE																
FMPPE2, type R/W, offset 0x408, reset 0xFFFF.FFFF																
PROG_ENABLE																
PROG_ENABLE																
FMPPE3, type R/W, offset 0x40C, reset 0xFFFF.FFFF																
PROG_ENABLE																
PROG_ENABLE																
BOOTCFG, type RO, offset 0x1D0, reset 0xFFFF.FFFE																
NW																
PORT				PIN				POL	EN						DBG1	DBG0
USER_REG0, type R/W, offset 0x1E0, reset 0xFFFF.FFFF																
DATA																
DATA																
USER_REG1, type R/W, offset 0x1E4, reset 0xFFFF.FFFF																
DATA																
DATA																
USER_REG2, type R/W, offset 0x1E8, reset 0xFFFF.FFFF																
DATA																
DATA																
USER_REG3, type R/W, offset 0x1EC, reset 0xFFFF.FFFF																
DATA																
DATA																
Micro Direct Memory Access (μDMA)																
μDMA Channel Control Structure (Offset from Channel Control Table Base)																
Base n/a																
DMASRCNDP, type R/W, offset 0x000, reset -																
ADDR																
ADDR																
DMADSTNDP, type R/W, offset 0x004, reset -																
ADDR																
ADDR																
DMACHCTL, type R/W, offset 0x008, reset -																
DSTINC	DSTSIZE			SRCINC	SRCSIZE									ARBSIZE		
ARBSIZE		XFERSIZE										NXTUSEBURST	XFERMODE			

31	30	29	28	27	26	25	24	23	22	21	20	19	18	17	16
15	14	13	12	11	10	9	8	7	6	5	4	3	2	1	0
Micro Direct Memory Access (μDMA)															
μDMA Registers (Offset from μDMA Base Address)															
Base 0x400F.F000															
DMASSTAT, type RO, offset 0x000, reset 0x001F.0000															
												DMACHANS			
												STATE		MASTEN	
DMACFG, type WO, offset 0x004, reset -															
														MASTEN	
DMACTLBASE, type R/W, offset 0x008, reset 0x0000.0000															
												ADDR			
ADDR															
DMAALTBASE, type RO, offset 0x00C, reset 0x0000.0200															
												ADDR			
												ADDR			
DMAWAITSTAT, type RO, offset 0x010, reset 0xFFFF.FFC0															
												WAITREQ[n]			
												WAITREQ[n]			
DMASWREQ, type WO, offset 0x014, reset -															
												SWREQ[n]			
												SWREQ[n]			
DMAUSEBURSTSET, type R/W, offset 0x018, reset 0x0000.0000															
												SET[n]			
												SET[n]			
DMAUSEBURSTCLR, type WO, offset 0x01C, reset -															
												CLR[n]			
												CLR[n]			
DMAREQMASKSET, type R/W, offset 0x020, reset 0x0000.0000															
												SET[n]			
												SET[n]			
DMAREQMASKCLR, type WO, offset 0x024, reset -															
												CLR[n]			
												CLR[n]			
DMAENASET, type R/W, offset 0x028, reset 0x0000.0000															
												SET[n]			
												SET[n]			
DMAENACLRL, type WO, offset 0x02C, reset -															
												CLR[n]			
												CLR[n]			
DMAALTSET, type R/W, offset 0x030, reset 0x0000.0000															
												SET[n]			
												SET[n]			
DMAALTCLR, type WO, offset 0x034, reset -															
												CLR[n]			
												CLR[n]			
DMAPRIOSET, type R/W, offset 0x038, reset 0x0000.0000															
												SET[n]			
												SET[n]			
DMAPRIOCLR, type WO, offset 0x03C, reset -															
												CLR[n]			
												CLR[n]			

31	30	29	28	27	26	25	24	23	22	21	20	19	18	17	16
15	14	13	12	11	10	9	8	7	6	5	4	3	2	1	0
DMAERRCLR, type R/W, offset 0x04C, reset 0x0000.0000															
															ERRCLR
DMACHASGN, type R/W, offset 0x500, reset 0x0000.0000															
															CHASGN[n]
															CHASGN[n]
DMACHIS, type R/W1C, offset 0x504, reset 0x0000.0000															
															CHIS[n]
															CHIS[n]
DMACHMAP0, type R/W, offset 0x510, reset 0x0000.0000															
CH7SEL				CH6SEL				CH5SEL				CH4SEL			
CH3SEL				CH2SEL				CH1SEL				CH0SEL			
DMACHMAP1, type R/W, offset 0x514, reset 0x0000.0000															
CH15SEL				CH14SEL				CH13SEL				CH12SEL			
CH11SEL				CH10SEL				CH9SEL				CH8SEL			
DMACHMAP2, type R/W, offset 0x518, reset 0x0000.0000															
CH23SEL				CH22SEL				CH21SEL				CH20SEL			
CH19SEL				CH18SEL				CH17SEL				CH16SEL			
DMACHMAP3, type R/W, offset 0x51C, reset 0x0000.0000															
CH31SEL				CH30SEL				CH29SEL				CH28SEL			
CH27SEL				CH26SEL				CH25SEL				CH24SEL			
DMAPeriphID0, type RO, offset 0xFE0, reset 0x0000.0030															
															PID0
DMAPeriphID1, type RO, offset 0xFE4, reset 0x0000.00B2															
															PID1
DMAPeriphID2, type RO, offset 0xFE8, reset 0x0000.000B															
															PID2
DMAPeriphID3, type RO, offset 0xFEC, reset 0x0000.0000															
															PID3
DMAPeriphID4, type RO, offset 0xFD0, reset 0x0000.0004															
															PID4
DMAPELID0, type RO, offset 0xFF0, reset 0x0000.000D															
															CID0
DMAPELID1, type RO, offset 0xFF4, reset 0x0000.00F0															
															CID1
DMAPELID2, type RO, offset 0xFF8, reset 0x0000.0005															
															CID2
DMAPELID3, type RO, offset 0xFFC, reset 0x0000.00B1															
															CID3

31	30	29	28	27	26	25	24	23	22	21	20	19	18	17	16
15	14	13	12	11	10	9	8	7	6	5	4	3	2	1	0
General-Purpose Input/Outputs (GPIOs)															
GPIO Port A (APB) base: 0x4000.4000															
GPIO Port A (AHB) base: 0x4005.8000															
GPIO Port B (APB) base: 0x4000.5000															
GPIO Port B (AHB) base: 0x4005.9000															
GPIO Port C (APB) base: 0x4000.6000															
GPIO Port C (AHB) base: 0x4005.A000															
GPIO Port D (APB) base: 0x4000.7000															
GPIO Port D (AHB) base: 0x4005.B000															
GPIO Port E (APB) base: 0x4002.4000															
GPIO Port E (AHB) base: 0x4005.C000															
GPIO Port F (APB) base: 0x4002.5000															
GPIO Port F (AHB) base: 0x4005.D000															
GPIO Port G (APB) base: 0x4002.6000															
GPIO Port G (AHB) base: 0x4005.E000															
GPIODATA, type R/W, offset 0x000, reset 0x0000.0000 (see page 635)															
DATA															
GPIODIR, type R/W, offset 0x400, reset 0x0000.0000 (see page 636)															
DIR															
GPIOIS, type R/W, offset 0x404, reset 0x0000.0000 (see page 637)															
IS															
GPIOIBE, type R/W, offset 0x408, reset 0x0000.0000 (see page 638)															
IBE															
GPIOIEV, type R/W, offset 0x40C, reset 0x0000.0000 (see page 639)															
IEV															
GPIOIM, type R/W, offset 0x410, reset 0x0000.0000 (see page 640)															
IME															
GPIORIS, type RO, offset 0x414, reset 0x0000.0000 (see page 641)															
RIS															
GPIONIS, type RO, offset 0x418, reset 0x0000.0000 (see page 642)															
MIS															
GPIOICR, type W1C, offset 0x41C, reset 0x0000.0000 (see page 643)															
IC															
GPIOAFSEL, type R/W, offset 0x420, reset - (see page 644)															
AFSEL															
GPIODR2R, type R/W, offset 0x500, reset 0x0000.00FF (see page 646)															
DRV2															
GPIODR4R, type R/W, offset 0x504, reset 0x0000.0000 (see page 647)															
DRV4															
GPIODR8R, type R/W, offset 0x508, reset 0x0000.0000 (see page 648)															
DRV8															
GPIOODR, type R/W, offset 0x50C, reset 0x0000.0000 (see page 649)															
ODE															

31	30	29	28	27	26	25	24	23	22	21	20	19	18	17	16
15	14	13	12	11	10	9	8	7	6	5	4	3	2	1	0
GPIOPUR, type R/W, offset 0x510, reset - (see page 650)															
												PUE			
GPIOPDR, type R/W, offset 0x514, reset 0x0000.0000 (see page 652)															
												PDE			
GPIOSLR, type R/W, offset 0x518, reset 0x0000.0000 (see page 654)															
												SRL			
GPIODEN, type R/W, offset 0x51C, reset - (see page 655)															
												DEN			
GPIOLOCK, type R/W, offset 0x520, reset 0x0000.0001 (see page 657)															
								LOCK							
								LOCK							
GPIOCR, type -, offset 0x524, reset - (see page 658)															
												CR			
GPIOAMSEL, type R/W, offset 0x528, reset 0x0000.0000 (see page 660)															
												GPIOAMSEL			
GPIOPTCL, type R/W, offset 0x52C, reset - (see page 661)															
PMC7				PMC6				PMC5				PMC4			
PMC3				PMC2				PMC1				PMC0			
GPIOADCCTL, type R/W, offset 0x530, reset 0x0000.0000 (see page 663)															
												ADCEN			
GPIODMACTL, type R/W, offset 0x534, reset 0x0000.0000 (see page 664)															
												DMAEN			
GPIOPeriphID4, type RO, offset 0xFD0, reset 0x0000.0000 (see page 665)															
												PID4			
GPIOPeriphID5, type RO, offset 0xFD4, reset 0x0000.0000 (see page 666)															
												PID5			
GPIOPeriphID6, type RO, offset 0xFD8, reset 0x0000.0000 (see page 667)															
												PID6			
GPIOPeriphID7, type RO, offset 0xFDC, reset 0x0000.0000 (see page 668)															
												PID7			
GPIOPeriphID0, type RO, offset 0xFE0, reset 0x0000.0061 (see page 669)															
												PID0			
GPIOPeriphID1, type RO, offset 0xFE4, reset 0x0000.0000 (see page 670)															
												PID1			
GPIOPeriphID2, type RO, offset 0xFE8, reset 0x0000.0018 (see page 671)															
												PID2			

31	30	29	28	27	26	25	24	23	22	21	20	19	18	17	16																												
15	14	13	12	11	10	9	8	7	6	5	4	3	2	1	0																												
GPIOPeriphID3, type RO, offset 0xFEC, reset 0x0000.0001 (see page 672)																																											
PID3																																											
GPIOCellID0, type RO, offset 0xFF0, reset 0x0000.000D (see page 673)																																											
CID0																																											
GPIOCellID1, type RO, offset 0xFF4, reset 0x0000.00F0 (see page 674)																																											
CID1																																											
GPIOCellID2, type RO, offset 0xFF8, reset 0x0000.0005 (see page 675)																																											
CID2																																											
GPIOCellID3, type RO, offset 0xFFC, reset 0x0000.00B1 (see page 676)																																											
CID3																																											
General-Purpose Timers																																											
16/32-bit Timer 0 base: 0x4003.0000																																											
16/32-bit Timer 1 base: 0x4003.1000																																											
16/32-bit Timer 2 base: 0x4003.2000																																											
16/32-bit Timer 3 base: 0x4003.3000																																											
16/32-bit Timer 4 base: 0x4003.4000																																											
16/32-bit Timer 5 base: 0x4003.5000																																											
32/64-bit Wide Timer 0 base: 0x4003.6000																																											
32/64-bit Wide Timer 1 base: 0x4003.7000																																											
32/64-bit Wide Timer 2 base: 0x4004.C000																																											
32/64-bit Wide Timer 3 base: 0x4004.D000																																											
32/64-bit Wide Timer 4 base: 0x4004.E000																																											
32/64-bit Wide Timer 5 base: 0x4004.F000																																											
GPTMCFG, type R/W, offset 0x000, reset 0x0000.0000 (see page 700)																																											
GPTMCFG																																											
GPTMTAMR, type R/W, offset 0x004, reset 0x0000.0000 (see page 702)																																											
TAPLO				TAMRSU				TAPWMIE				TAILD				TASNAPS				TAWOT				TAMIE				TACDIR				TAAMS				TACMR				TAMR			
GPTMTBMR, type R/W, offset 0x008, reset 0x0000.0000 (see page 706)																																											
TBPLO				TBMRSU				TBPWMIE				TBILD				TBSNAPS				TBWOT				TBMIE				TBCDIR				TBAMS				TBCMR				TBMR			
GPTMCTL, type R/W, offset 0x00C, reset 0x0000.0000 (see page 710)																																											
TBPWML				TBOTE				TBEVENT				TBSTALL				TBEN				TAPWML				TAOTE				RTCEN				TAEVENT				TASTALL				TAEN			
GPTMSYNC, type R/W, offset 0x010, reset 0x0000.0000 (see page 714)																																											
SYNCWT1				SYNCWT0				SYNCT5				SYNCT4				SYNCT3				SYNCT2				SYNCT1				SYNCT0															
GPTMIMR, type R/W, offset 0x018, reset 0x0000.0000 (see page 718)																																											
TBMIM				CBEIM				CBMIM				TBTOIM				TAMIM				RTCIM				CAEIM				CAMIM				TATOIM											
GPTMRIS, type RO, offset 0x01C, reset 0x0000.0000 (see page 721)																																											
TBMRIS				CBERIS				CBMRIS				TBTORIS				TAMRIS				RTCIRIS				CAERIS				CAMRIS				TATORIS											
GPTMMIS, type RO, offset 0x020, reset 0x0000.0000 (see page 724)																																											
TBMNIS				CBEMIS				CBMMIS				TBTOMIS				TAMNIS				RTCMIS				CAEMIS				CAMNIS				TATOMIS											
GPTMICR, type W1C, offset 0x024, reset 0x0000.0000 (see page 727)																																											
TBMNCINT				CBECINT				CBMCINT				TBTOCINT				TAMNCINT				RTCCINT				CAECINT				CAMNCINT				TATOCINT											

31	30	29	28	27	26	25	24	23	22	21	20	19	18	17	16								
15	14	13	12	11	10	9	8	7	6	5	4	3	2	1	0								
GPTMTAILR, type R/W, offset 0x028, reset 0xFFFF.FFFF (see page 729)																							
								TAILR															
								TAILR															
GPTMTBILR, type R/W, offset 0x02C, reset - (see page 730)																							
								TBILR															
								TBILR															
GPTMTAMATCHR, type R/W, offset 0x030, reset 0xFFFF.FFFF (see page 731)																							
								TAMR															
								TAMR															
GPTMTBMATCHR, type R/W, offset 0x034, reset - (see page 732)																							
								TBMR															
								TBMR															
GPTMTAPR, type R/W, offset 0x038, reset 0x0000.0000 (see page 733)																							
								TAPSRH								TAPSR							
GPTMTBPR, type R/W, offset 0x03C, reset 0x0000.0000 (see page 734)																							
								TBPSRH								TBPSR							
GPTMTAPMR, type R/W, offset 0x040, reset 0x0000.0000 (see page 735)																							
								TAPSMRH								TAPSMR							
GPTMTBPMR, type R/W, offset 0x044, reset 0x0000.0000 (see page 736)																							
								TBPSMRH								TBPSMR							
GPTMTAR, type RO, offset 0x048, reset 0xFFFF.FFFF (see page 737)																							
								TAR															
								TAR															
GPTMTBR, type RO, offset 0x04C, reset - (see page 738)																							
								TBR															
								TBR															
GPTMTAV, type RW, offset 0x050, reset 0xFFFF.FFFF (see page 739)																							
								TAV															
								TAV															
GPTMTBV, type RW, offset 0x054, reset - (see page 740)																							
								TBV															
								TBV															
GPTMRTCPD, type RO, offset 0x058, reset 0x0000.7FFF (see page 741)																							
								RTCPD															
GPTMTAPS, type RO, offset 0x05C, reset 0x0000.0000 (see page 742)																							
								PSS															
GPTMTBPS, type RO, offset 0x060, reset 0x0000.0000 (see page 743)																							
								PSS															
GPTMTAPV, type RO, offset 0x064, reset 0x0000.0000 (see page 744)																							
								PSV															
GPTMTBPV, type RO, offset 0x068, reset 0x0000.0000 (see page 745)																							
								PSV															

31	30	29	28	27	26	25	24	23	22	21	20	19	18	17	16
15	14	13	12	11	10	9	8	7	6	5	4	3	2	1	0
GPTMPP, type RO, offset 0xFC0, reset 0x0000.0000 (see page 746)															
SIZE															
Watchdog Timers															
WDT0 base: 0x4000.0000															
WDT1 base: 0x4000.1000															
WDTLOAD, type R/W, offset 0x000, reset 0xFFFF.FFFF (see page 751)															
WDTLOAD															
WDTLOAD															
WDTVALUE, type RO, offset 0x004, reset 0xFFFF.FFFF (see page 752)															
WDTVALUE															
WDTVALUE															
WDTCTL, type R/W, offset 0x008, reset 0x0000.0000 (WDT0) and 0x8000.0000 (WDT1) (see page 753)															
WRC													INTTYPE	RESEN	INTEN
WDTICR, type WO, offset 0x00C, reset - (see page 755)															
WDTINTCLR															
WDTINTCLR															
WDTRIS, type RO, offset 0x010, reset 0x0000.0000 (see page 756)															
															WDTRIS
WDTMIS, type RO, offset 0x014, reset 0x0000.0000 (see page 757)															
															WDTMIS
WDTTEST, type R/W, offset 0x418, reset 0x0000.0000 (see page 758)															
															STALL
WDTLOCK, type R/W, offset 0xC00, reset 0x0000.0000 (see page 759)															
WDTLOCK															
WDTLOCK															
WDTPeriphID4, type RO, offset 0xFD0, reset 0x0000.0000 (see page 760)															
															PID4
WDTPeriphID5, type RO, offset 0xFD4, reset 0x0000.0000 (see page 761)															
															PID5
WDTPeriphID6, type RO, offset 0xFD8, reset 0x0000.0000 (see page 762)															
															PID6
WDTPeriphID7, type RO, offset 0xFDC, reset 0x0000.0000 (see page 763)															
															PID7
WDTPeriphID0, type RO, offset 0xFE0, reset 0x0000.0005 (see page 764)															
															PID0
WDTPeriphID1, type RO, offset 0xFE4, reset 0x0000.0018 (see page 765)															
															PID1
WDTPeriphID2, type RO, offset 0xFE8, reset 0x0000.0018 (see page 766)															
															PID2

31	30	29	28	27	26	25	24	23	22	21	20	19	18	17	16
15	14	13	12	11	10	9	8	7	6	5	4	3	2	1	0
WDTPeriphID3, type RO, offset 0xFEC, reset 0x0000.0001 (see page 767)															
												PID3			
WDTPCellID0, type RO, offset 0xFF0, reset 0x0000.000D (see page 768)															
												CID0			
WDTPCellID1, type RO, offset 0xFF4, reset 0x0000.00F0 (see page 769)															
												CID1			
WDTPCellID2, type RO, offset 0xFF8, reset 0x0000.0006 (see page 770)															
												CID2			
WDTPCellID3, type RO, offset 0xFFC, reset 0x0000.00B1 (see page 771)															
												CID3			
Analog-to-Digital Converter (ADC)															
ADC0 base: 0x4003.8000															
ADC1 base: 0x4003.9000															
ADCACTSS, type R/W, offset 0x000, reset 0x0000.0000 (see page 793)															
												ASEN3	ASEN2	ASEN1	ASEN0
ADCRIS, type RO, offset 0x004, reset 0x0000.0000 (see page 794)															
												INR3	INR2	INR1	INR0
ADCIM, type R/W, offset 0x008, reset 0x0000.0000 (see page 796)															
												DCONSS3	DCONSS2	DCONSS1	DCONSS0
												MASK3	MASK2	MASK1	MASK0
ADCISC, type R/W1C, offset 0x00C, reset 0x0000.0000 (see page 798)															
												DCINSS3	DCINSS2	DCINSS1	DCINSS0
												IN3	IN2	IN1	IN0
ADCOSTAT, type R/W1C, offset 0x010, reset 0x0000.0000 (see page 801)															
												OV3	OV2	OV1	OV0
ADCEMUX, type R/W, offset 0x014, reset 0x0000.0000 (see page 803)															
EM3				EM2				EM1				EM0			
ADCUSTAT, type R/W1C, offset 0x018, reset 0x0000.0000 (see page 808)															
												UV3	UV2	UV1	UV0
ADCTSSEL, type R/W, offset 0x01C, reset 0x0000.0000 (see page 809)															
PS3				PS2				PS1				PS0			
ADCSSPRI, type R/W, offset 0x020, reset 0x0000.3210 (see page 811)															
SS3				SS2				SS1				SS0			
ADCSPC, type R/W, offset 0x024, reset 0x0000.0000 (see page 813)															
												PHASE			
ADCPSSI, type R/W, offset 0x028, reset - (see page 815)															
GSYNC				SYNCWAIT											
												SS3	SS2	SS1	SS0

31	30	29	28	27	26	25	24	23	22	21	20	19	18	17	16
15	14	13	12	11	10	9	8	7	6	5	4	3	2	1	0
ADCSSAC , type R/W, offset 0x030, reset 0x0000.0000 (see page 817)															
AVG															
ADCDCISC , type R/W1C, offset 0x034, reset 0x0000.0000 (see page 818)															
DCINT7 DCINT6 DCINT5 DCINT4 DCINT3 DCINT2 DCINT1 DCINT0															
ADCSSMUX0 , type R/W, offset 0x040, reset 0x0000.0000 (see page 820)															
MUX7				MUX6				MUX5				MUX4			
MUX3				MUX2				MUX1				MUX0			
ADCSSCTL0 , type R/W, offset 0x044, reset 0x0000.0000 (see page 822)															
TS7	IE7	END7	D7	TS6	IE6	END6	D6	TS5	IE5	END5	D5	TS4	IE4	END4	D4
TS3	IE3	END3	D3	TS2	IE2	END2	D2	TS1	IE1	END1	D1	TS0	IE0	END0	D0
ADCSSFIFO0 , type RO, offset 0x048, reset - (see page 825)															
DATA															
ADCSSFIFO1 , type RO, offset 0x068, reset - (see page 825)															
DATA															
ADCSSFIFO2 , type RO, offset 0x088, reset - (see page 825)															
DATA															
ADCSSFIFO3 , type RO, offset 0x0A8, reset - (see page 825)															
DATA															
ADCSSFSTAT0 , type RO, offset 0x04C, reset 0x0000.0100 (see page 826)															
FULL				EMPTY				HPTR				TPTR			
ADCSSFSTAT1 , type RO, offset 0x06C, reset 0x0000.0100 (see page 826)															
FULL				EMPTY				HPTR				TPTR			
ADCSSFSTAT2 , type RO, offset 0x08C, reset 0x0000.0100 (see page 826)															
FULL				EMPTY				HPTR				TPTR			
ADCSSFSTAT3 , type RO, offset 0x0AC, reset 0x0000.0100 (see page 826)															
FULL				EMPTY				HPTR				TPTR			
ADCSSOP0 , type R/W, offset 0x050, reset 0x0000.0000 (see page 828)															
S7DCOP				S6DCOP				S5DCOP				S4DCOP			
S3DCOP				S2DCOP				S1DCOP				S0DCOP			
ADCSSDC0 , type R/W, offset 0x054, reset 0x0000.0000 (see page 830)															
S7DCSEL				S6DCSEL				S5DCSEL				S4DCSEL			
S3DCSEL				S2DCSEL				S1DCSEL				S0DCSEL			
ADCSSMUX1 , type R/W, offset 0x060, reset 0x0000.0000 (see page 832)															
MUX3				MUX2				MUX1				MUX0			
ADCSSMUX2 , type R/W, offset 0x080, reset 0x0000.0000 (see page 832)															
MUX3				MUX2				MUX1				MUX0			
ADCSSCTL1 , type R/W, offset 0x064, reset 0x0000.0000 (see page 833)															
TS3	IE3	END3	D3	TS2	IE2	END2	D2	TS1	IE1	END1	D1	TS0	IE0	END0	D0

31	30	29	28	27	26	25	24	23	22	21	20	19	18	17	16	
15	14	13	12	11	10	9	8	7	6	5	4	3	2	1	0	
ADCSSCTL2, type R/W, offset 0x084, reset 0x0000.0000 (see page 833)																
	TS3	IE3	END3	D3	TS2	IE2	END2	D2	TS1	IE1	END1	D1	TS0	IE0	END0	D0
ADCSSOP1, type R/W, offset 0x070, reset 0x0000.0000 (see page 835)																
			S3DCOP				S2DCOP				S1DCOP				S0DCOP	
ADCSSOP2, type R/W, offset 0x090, reset 0x0000.0000 (see page 835)																
			S3DCOP				S2DCOP				S1DCOP				S0DCOP	
ADCSSDC1, type R/W, offset 0x074, reset 0x0000.0000 (see page 836)																
			S3DCSEL				S2DCSEL				S1DCSEL				S0DCSEL	
ADCSSDC2, type R/W, offset 0x094, reset 0x0000.0000 (see page 836)																
			S3DCSEL				S2DCSEL				S1DCSEL				S0DCSEL	
ADCSSMUX3, type R/W, offset 0x0A0, reset 0x0000.0000 (see page 838)																
															MUX0	
ADCSSCTL3, type R/W, offset 0x0A4, reset 0x0000.0000 (see page 839)																
													TS0	IE0	END0	D0
ADCSSOP3, type R/W, offset 0x0B0, reset 0x0000.0000 (see page 840)																
															S0DCOP	
ADCSSDC3, type R/W, offset 0x0B4, reset 0x0000.0000 (see page 841)																
															S0DCSEL	
ADCDCRIC, type WO, offset 0xD00, reset 0x0000.0000 (see page 842)																
								DCTRIG7	DCTRIG6	DCTRIG5	DCTRIG4	DCTRIG3	DCTRIG2	DCTRIG1	DCTRIG0	
								DCINT7	DCINT6	DCINT5	DCINT4	DCINT3	DCINT2	DCINT1	DCINT0	
ADCDCCTL0, type R/W, offset 0xE00, reset 0x0000.0000 (see page 847)																
			CTE		CTC		CTM				CIE		CIC		CIM	
ADCDCCTL1, type R/W, offset 0xE04, reset 0x0000.0000 (see page 847)																
			CTE		CTC		CTM				CIE		CIC		CIM	
ADCDCCTL2, type R/W, offset 0xE08, reset 0x0000.0000 (see page 847)																
			CTE		CTC		CTM				CIE		CIC		CIM	
ADCDCCTL3, type R/W, offset 0xE0C, reset 0x0000.0000 (see page 847)																
			CTE		CTC		CTM				CIE		CIC		CIM	
ADCDCCTL4, type R/W, offset 0xE10, reset 0x0000.0000 (see page 847)																
			CTE		CTC		CTM				CIE		CIC		CIM	
ADCDCCTL5, type R/W, offset 0xE14, reset 0x0000.0000 (see page 847)																
			CTE		CTC		CTM				CIE		CIC		CIM	
ADCDCCTL6, type R/W, offset 0xE18, reset 0x0000.0000 (see page 847)																
			CTE		CTC		CTM				CIE		CIC		CIM	

31	30	29	28	27	26	25	24	23	22	21	20	19	18	17	16								
15	14	13	12	11	10	9	8	7	6	5	4	3	2	1	0								
ADDCCTL7, type R/W, offset 0xE1C, reset 0x0000.0000 (see page 847)																							
				CTE				CTC				CTM						CIE		CIC		CIM	
ADDCCMP0, type R/W, offset 0xE40, reset 0x0000.0000 (see page 850)																							
										COMP1													
										COMP0													
ADDCCMP1, type R/W, offset 0xE44, reset 0x0000.0000 (see page 850)																							
										COMP1													
										COMP0													
ADDCCMP2, type R/W, offset 0xE48, reset 0x0000.0000 (see page 850)																							
										COMP1													
										COMP0													
ADDCCMP3, type R/W, offset 0xE4C, reset 0x0000.0000 (see page 850)																							
										COMP1													
										COMP0													
ADDCCMP4, type R/W, offset 0xE50, reset 0x0000.0000 (see page 850)																							
										COMP1													
										COMP0													
ADDCCMP5, type R/W, offset 0xE54, reset 0x0000.0000 (see page 850)																							
										COMP1													
										COMP0													
ADDCCMP6, type R/W, offset 0xE58, reset 0x0000.0000 (see page 850)																							
										COMP1													
										COMP0													
ADDCMP7, type R/W, offset 0xE5C, reset 0x0000.0000 (see page 850)																							
										COMP1													
										COMP0													
ADCPP, type RO, offset 0xFC0, reset 0x00B0.20C7 (see page 851)																							
DC								TS		RSL				TYPE									
								CH						MSR									
ADCPC, type R/W, offset 0xFC4, reset 0x0000.0007 (see page 853)																							
												SR											
ADCCC, type R/W, offset 0xFC8, reset 0x0000.0000 (see page 854)																							
												CS											
Universal Asynchronous Receivers/Transmitters (UARTs)																							
UART0 base: 0x4000.C000																							
UART1 base: 0x4000.D000																							
UART2 base: 0x4000.E000																							
UART3 base: 0x4000.F000																							
UART4 base: 0x4001.0000																							
UART5 base: 0x4001.1000																							
UART6 base: 0x4001.2000																							
UART7 base: 0x4001.3000																							
UARTDR, type R/W, offset 0x000, reset 0x0000.0000 (see page 869)																							
								OE		BE		PE		FE		DATA							
UARTSR/UARTECR, type RO, offset 0x004, reset 0x0000.0000 (Read-Only Status Register) (see page 871)																							
												OE		BE		PE		FE					
UARTSR/UARTECR, type WO, offset 0x004, reset 0x0000.0000 (Write-Only Error Clear Register) (see page 871)																							
												DATA											

31	30	29	28	27	26	25	24	23	22	21	20	19	18	17	16		
15	14	13	12	11	10	9	8	7	6	5	4	3	2	1	0		
UARTFR, type RO, offset 0x018, reset 0x0000.0090 (see page 874)																	
								TXFE	RXFF	TXFF	RXFE	BUSY		CTS			
UARTILPR, type R/W, offset 0x020, reset 0x0000.0000 (see page 876)																	
												ILPDVSR					
UARTIBRD, type R/W, offset 0x024, reset 0x0000.0000 (see page 877)																	
DIVINT																	
UARTFBRD, type R/W, offset 0x028, reset 0x0000.0000 (see page 878)																	
DIVFRAC																	
UARTLCRH, type R/W, offset 0x02C, reset 0x0000.0000 (see page 879)																	
				SPS		WLEN		FEN		STP2		EPS		BRK			
UARTCTL, type R/W, offset 0x030, reset 0x0000.0300 (see page 881)																	
				RXE		TXE		LBE		LIN		HSE		EOT			
				SMART		SIRLP		SIREN		UARTEN							
UARTIFLS, type R/W, offset 0x034, reset 0x0000.0012 (see page 885)																	
												RXIFLSEL		TXIFLSEL			
UARTIM, type R/W, offset 0x038, reset 0x0000.0000 (see page 887)																	
LME5IM		LME1IM		LMSBIM		9BITIM		OEIM		BEIM		PEIM		FEIM			
RTIM		TXIM		RXIM		CTSIM											
UARTRIS, type RO, offset 0x03C, reset 0x0000.000F (see page 890)																	
LME5RIS		LME1RIS		LMSBRIS		9BITRIS		OERIS		BERIS		PERIS		FERIS			
RTRIS		TXRIS		RXRIS		CTSRIS											
UARTMIS, type RO, offset 0x040, reset 0x0000.0000 (see page 893)																	
LME5MIS		LME1MIS		LMSBMIS		9BITMIS		OEMIS		BEMIS		PEMIS		FEMIS			
RTMIS		TXMIS		RXMIS		CTSMIS											
UARTICR, type W1C, offset 0x044, reset 0x0000.0000 (see page 896)																	
LME5IC		LME1IC		LMSBIC		9BITIC		OEIC		BEIC		PEIC		FEIC			
RTIC		TXIC		RXIC		CTSMIC											
UARTDMACTL, type R/W, offset 0x048, reset 0x0000.0000 (see page 898)																	
												DMAERR		TXDMAE		RXDMAE	
UARTLCTL, type R/W, offset 0x090, reset 0x0000.0000 (see page 899)																	
												BLEN		MASTER			
UARTLSS, type RO, offset 0x094, reset 0x0000.0000 (see page 900)																	
TSS																	
UARTLTIM, type RO, offset 0x098, reset 0x0000.0000 (see page 901)																	
TIMER																	
UART9BITADDR, type R/W, offset 0x0A4, reset 0x0000.0000 (see page 902)																	
9BITEN				ADDR													
UART9BITAMASK, type R/W, offset 0x0A8, reset 0x0000.00FF (see page 903)																	
MASK																	

31	30	29	28	27	26	25	24	23	22	21	20	19	18	17	16
15	14	13	12	11	10	9	8	7	6	5	4	3	2	1	0
UARTPP , type RO, offset 0xFC0, reset 0x0000.0003 (see page 904)															
														NB	SC
UARTCC , type R/W, offset 0xFC8, reset 0x0000.0000 (see page 905)															
														CS	
UARTPeriphID4 , type RO, offset 0xFD0, reset 0x0000.0000 (see page 906)															
														PID4	
UARTPeriphID5 , type RO, offset 0xFD4, reset 0x0000.0000 (see page 907)															
														PID5	
UARTPeriphID6 , type RO, offset 0xFD8, reset 0x0000.0000 (see page 908)															
														PID6	
UARTPeriphID7 , type RO, offset 0xFDC, reset 0x0000.0000 (see page 909)															
														PID7	
UARTPeriphID0 , type RO, offset 0xFE0, reset 0x0000.0060 (see page 910)															
														PID0	
UARTPeriphID1 , type RO, offset 0xFE4, reset 0x0000.0000 (see page 911)															
														PID1	
UARTPeriphID2 , type RO, offset 0xFE8, reset 0x0000.0018 (see page 912)															
														PID2	
UARTPeriphID3 , type RO, offset 0xFEC, reset 0x0000.0001 (see page 913)															
														PID3	
UARTPCellID0 , type RO, offset 0xFF0, reset 0x0000.000D (see page 914)															
														CID0	
UARTPCellID1 , type RO, offset 0xFF4, reset 0x0000.00F0 (see page 915)															
														CID1	
UARTPCellID2 , type RO, offset 0xFF8, reset 0x0000.0005 (see page 916)															
														CID2	
UARTPCellID3 , type RO, offset 0xFFC, reset 0x0000.00B1 (see page 917)															
														CID3	
Synchronous Serial Interface (SSI)															
SSI0 base: 0x4000.8000															
SSI1 base: 0x4000.9000															
SSI2 base: 0x4000.A000															
SSI3 base: 0x4000.B000															
SSICR0 , type R/W, offset 0x000, reset 0x0000.0000 (see page 933)															
SCR								SPH	SPO	FRF	DSS				
SSICR1 , type R/W, offset 0x004, reset 0x0000.0000 (see page 935)															
										SLBY6	EOT	SOD	MS	SSE	LBM

31	30	29	28	27	26	25	24	23	22	21	20	19	18	17	16	
15	14	13	12	11	10	9	8	7	6	5	4	3	2	1	0	
SSIDR, type R/W, offset 0x008, reset 0x0000.0000 (see page 937)																
DATA																
SSISR, type RO, offset 0x00C, reset 0x0000.0003 (see page 938)																
												BSY	RFF	RNE	TNF	TFE
SSICPSR, type R/W, offset 0x010, reset 0x0000.0000 (see page 940)																
CPSDVSR																
SSIIM, type R/W, offset 0x014, reset 0x0000.0000 (see page 941)																
												TXIM	RXIM	RTIM	RORIM	
SSIRIS, type RO, offset 0x018, reset 0x0000.0008 (see page 942)																
												TXRIS	RXRIS	RTRIS	RORRIS	
SSIMIS, type RO, offset 0x01C, reset 0x0000.0000 (see page 944)																
												TXMIS	RXMIS	RTMIS	RORMIS	
SSIIICR, type W1C, offset 0x020, reset 0x0000.0000 (see page 946)																
														RTIC	RORIC	
SSIDMACTL, type R/W, offset 0x024, reset 0x0000.0000 (see page 947)																
														TXDMAE	RXDMAE	
SSICC, type R/W, offset 0xFC8, reset 0x0000.0000 (see page 948)																
CS																
SSIPeriphID4, type RO, offset 0xFD0, reset 0x0000.0000 (see page 949)																
PID4																
SSIPeriphID5, type RO, offset 0xFD4, reset 0x0000.0000 (see page 950)																
PID5																
SSIPeriphID6, type RO, offset 0xFD8, reset 0x0000.0000 (see page 951)																
PID6																
SSIPeriphID7, type RO, offset 0xFDC, reset 0x0000.0000 (see page 952)																
PID7																
SSIPeriphID0, type RO, offset 0xFE0, reset 0x0000.0022 (see page 953)																
PID0																
SSIPeriphID1, type RO, offset 0xFE4, reset 0x0000.0000 (see page 954)																
PID1																
SSIPeriphID2, type RO, offset 0xFE8, reset 0x0000.0018 (see page 955)																
PID2																
SSIPeriphID3, type RO, offset 0xFEC, reset 0x0000.0001 (see page 956)																
PID3																

31	30	29	28	27	26	25	24	23	22	21	20	19	18	17	16
15	14	13	12	11	10	9	8	7	6	5	4	3	2	1	0
SSIPCellID0, type RO, offset 0xFF0, reset 0x0000.000D (see page 957)															
CID0															
SSIPCellID1, type RO, offset 0xFF4, reset 0x0000.00F0 (see page 958)															
CID1															
SSIPCellID2, type RO, offset 0xFF8, reset 0x0000.0005 (see page 959)															
CID2															
SSIPCellID3, type RO, offset 0xFFC, reset 0x0000.00B1 (see page 960)															
CID3															
Inter-Integrated Circuit (I²C) Interface															
I²C Master															
I2C 0 base: 0x4002.0000															
I2C 1 base: 0x4002.1000															
I2C 2 base: 0x4002.2000															
I2C 3 base: 0x4002.3000															
I2C 4 base: 0x400C.0000															
I2C 5 base: 0x400C.1000															
I2CMSA, type R/W, offset 0x000, reset 0x0000.0000															
SA R/S															
I2CMCS, type RO, offset 0x004, reset 0x0000.0020 (Read-Only Status Register)															
CLKTO BUSBSY IDLE ARBLST DATAACK ADRACK ERROR BUSY															
I2CMCS, type WO, offset 0x004, reset 0x0000.0020 (Write-Only Control Register)															
HS ACK STOP START RUN															
I2CMDR, type R/W, offset 0x008, reset 0x0000.0000															
DATA															
I2CMTPR, type R/W, offset 0x00C, reset 0x0000.0001															
HS TPR															
I2CMIMR, type R/W, offset 0x010, reset 0x0000.0000															
CLKIM IM															
I2CMRIS, type RO, offset 0x014, reset 0x0000.0000															
CLKRIS RIS															
I2CMMIS, type RO, offset 0x018, reset 0x0000.0000															
CLKMIS MIS															
I2CMICR, type WO, offset 0x01C, reset 0x0000.0000															
CLKIC IC															
I2CMCR, type R/W, offset 0x020, reset 0x0000.0000															
SFE MFE LPBK															
I2MCLKCNT, type R/W, offset 0x024, reset 0x0000.0000															
CNTL															

31	30	29	28	27	26	25	24	23	22	21	20	19	18	17	16
15	14	13	12	11	10	9	8	7	6	5	4	3	2	1	0
I2CMBMON, type RO, offset 0x02C, reset 0x0000.0003															
														SDA	SCL
Inter-Integrated Circuit (I²C) Interface															
I²C Slave															
I2C 0 base: 0x4002.0000															
I2C 1 base: 0x4002.1000															
I2C 2 base: 0x4002.2000															
I2C 3 base: 0x4002.3000															
I2C 4 base: 0x400C.0000															
I2C 5 base: 0x400C.1000															
I2CSOAR, type R/W, offset 0x800, reset 0x0000.0000															
														OAR	
I2CSCSR, type RO, offset 0x804, reset 0x0000.0000 (Read-Only Status Register)															
												OAR2SEL	FBR	TREQ	RREQ
I2CSCSR, type WO, offset 0x804, reset 0x0000.0000 (Write-Only Control Register)															
														DA	
I2CSDR, type R/W, offset 0x808, reset 0x0000.0000															
														DATA	
I2CSIMR, type R/W, offset 0x80C, reset 0x0000.0000															
												STOPIM	STARTIM	DATAIM	
I2CSRIS, type RO, offset 0x810, reset 0x0000.0000															
												STOPRIS	STARTRIS	DATARIS	
I2CSMIS, type RO, offset 0x814, reset 0x0000.0000															
												STOPMIS	STARTMIS	DATAMIS	
I2CSICR, type WO, offset 0x818, reset 0x0000.0000															
												STOPIC	STARTIC	DATAIC	
I2CSOAR2, type R/W, offset 0x81C, reset 0x0000.0000															
								OAR2EN	OAR2						
I2CSACKCTL, type R/W, offset 0x820, reset 0x0000.0000															
														ACKOVAL	ACKOEN
Inter-Integrated Circuit (I²C) Interface															
I²C Status and Control															
I2C 0 base: 0x4002.0000															
I2C 1 base: 0x4002.1000															
I2C 2 base: 0x4002.2000															
I2C 3 base: 0x4002.3000															
I2C 4 base: 0x400C.0000															
I2C 5 base: 0x400C.1000															
I2CPP, type RO, offset 0xFC0, reset 0x0000.0001															
														HS	
I2CPC, type RO, offset 0xFC4, reset 0x0000.0001															
														HS	

31	30	29	28	27	26	25	24	23	22	21	20	19	18	17	16		
15	14	13	12	11	10	9	8	7	6	5	4	3	2	1	0		
Controller Area Network (CAN) Module																	
CAN0 base: 0x4004.0000 CAN1 base: 0x4004.1000																	
CANCTL, type R/W, offset 0x000, reset 0x0000.0001 (see page 1030)																	
								TEST	CCE	DAR			EIE	SIE	IE	INIT	
CANSTS, type R/W, offset 0x004, reset 0x0000.0000 (see page 1032)																	
								BOFF	EWARN	EPASS	RXOK	TXOK	LEC				
CANERR, type RO, offset 0x008, reset 0x0000.0000 (see page 1035)																	
RP				REC				TEC									
CANBIT, type R/W, offset 0x00C, reset 0x0000.2301 (see page 1036)																	
TSEG2				TSEG1				SJW				BRP					
CANINT, type RO, offset 0x010, reset 0x0000.0000 (see page 1037)																	
								INTID									
CANTST, type R/W, offset 0x014, reset 0x0000.0000 (see page 1038)																	
								RX	TX		LBACK	SILENT	BASIC				
CANBRPE, type R/W, offset 0x018, reset 0x0000.0000 (see page 1040)																	
								BRPE									
CANIF1CRQ, type R/W, offset 0x020, reset 0x0000.0001 (see page 1041)																	
BUSY								MNUM									
CANIF2CRQ, type R/W, offset 0x080, reset 0x0000.0001 (see page 1041)																	
BUSY								MNUM									
CANIF1CMSK, type R/W, offset 0x024, reset 0x0000.0000 (see page 1042)																	
								WRNRD	MASK	ARB	CONTROL	CLRINTPND	NEWDAT / TXRQST	DATAA	DATAB		
CANIF2CMSK, type R/W, offset 0x084, reset 0x0000.0000 (see page 1042)																	
								WRNRD	MASK	ARB	CONTROL	CLRINTPND	NEWDAT / TXRQST	DATAA	DATAB		
CANIF1MSK1, type R/W, offset 0x028, reset 0x0000.FFFF (see page 1045)																	
								MSK									
CANIF2MSK1, type R/W, offset 0x088, reset 0x0000.FFFF (see page 1045)																	
								MSK									
CANIF1MSK2, type R/W, offset 0x02C, reset 0x0000.FFFF (see page 1046)																	
MXTD		MDIR										MSK					
CANIF2MSK2, type R/W, offset 0x08C, reset 0x0000.FFFF (see page 1046)																	
MXTD		MDIR										MSK					
CANIF1ARB1, type R/W, offset 0x030, reset 0x0000.0000 (see page 1048)																	
								ID									

31	30	29	28	27	26	25	24	23	22	21	20	19	18	17	16				
15	14	13	12	11	10	9	8	7	6	5	4	3	2	1	0				
CANIF2ARB1, type R/W, offset 0x090, reset 0x0000.0000 (see page 1048)																			
ID																			
CANIF1ARB2, type R/W, offset 0x034, reset 0x0000.0000 (see page 1049)																			
MSGVAL			XTD			DIR			ID										
CANIF2ARB2, type R/W, offset 0x094, reset 0x0000.0000 (see page 1049)																			
MSGVAL			XTD			DIR			ID										
CANIF1MCTL, type R/W, offset 0x038, reset 0x0000.0000 (see page 1051)																			
NEWDAT		MSGLST		INTPND		UMASK		TXIE		RXIE		RMTEN		TXRQST		EOB		DLC	
CANIF2MCTL, type R/W, offset 0x098, reset 0x0000.0000 (see page 1051)																			
NEWDAT		MSGLST		INTPND		UMASK		TXIE		RXIE		RMTEN		TXRQST		EOB		DLC	
CANIF1DA1, type R/W, offset 0x03C, reset 0x0000.0000 (see page 1054)																			
DATA																			
CANIF1DA2, type R/W, offset 0x040, reset 0x0000.0000 (see page 1054)																			
DATA																			
CANIF1DB1, type R/W, offset 0x044, reset 0x0000.0000 (see page 1054)																			
DATA																			
CANIF1DB2, type R/W, offset 0x048, reset 0x0000.0000 (see page 1054)																			
DATA																			
CANIF2DA1, type R/W, offset 0x09C, reset 0x0000.0000 (see page 1054)																			
DATA																			
CANIF2DA2, type R/W, offset 0x0A0, reset 0x0000.0000 (see page 1054)																			
DATA																			
CANIF2DB1, type R/W, offset 0x0A4, reset 0x0000.0000 (see page 1054)																			
DATA																			
CANIF2DB2, type R/W, offset 0x0A8, reset 0x0000.0000 (see page 1054)																			
DATA																			
CANTXRQ1, type RO, offset 0x100, reset 0x0000.0000 (see page 1055)																			
TXRQST																			
CANTXRQ2, type RO, offset 0x104, reset 0x0000.0000 (see page 1055)																			
TXRQST																			
CANNWDA1, type RO, offset 0x120, reset 0x0000.0000 (see page 1056)																			
NEWDAT																			
CANNWDA2, type RO, offset 0x124, reset 0x0000.0000 (see page 1056)																			
NEWDAT																			

31	30	29	28	27	26	25	24	23	22	21	20	19	18	17	16		
15	14	13	12	11	10	9	8	7	6	5	4	3	2	1	0		
CANMSG1INT, type RO, offset 0x140, reset 0x0000.0000 (see page 1057)																	
INTPND																	
CANMSG2INT, type RO, offset 0x144, reset 0x0000.0000 (see page 1057)																	
INTPND																	
CANMSG1VAL, type RO, offset 0x160, reset 0x0000.0000 (see page 1058)																	
MSGVAL																	
CANMSG2VAL, type RO, offset 0x164, reset 0x0000.0000 (see page 1058)																	
MSGVAL																	
Universal Serial Bus (USB) Controller																	
Base 0x4005.0000																	
USBFADDR, type R/W, offset 0x000, reset 0x00 (see page 1081)																	
FUNCADDR																	
USBPOWER, type R/W, offset 0x001, reset 0x20 (OTG A / Host Mode) (see page 1082)																	
												RESET	RESUME	SUSPEND	PWRDNPHY		
USBPOWER, type R/W, offset 0x001, reset 0x20 (OTG B / Device Mode) (see page 1082)																	
								ISOUP	SOFTCONN			RESET	RESUME	SUSPEND	PWRDNPHY		
USBTXIS, type RO, offset 0x002, reset 0x0000 (see page 1085)																	
				EP7	EP6	EP5	EP4	EP3	EP2	EP1	EP0						
USBRXIS, type RO, offset 0x004, reset 0x0000 (see page 1087)																	
				EP7	EP6	EP5	EP4	EP3	EP2	EP1							
USBTXIE, type R/W, offset 0x006, reset 0xFFFF (see page 1088)																	
				EP7	EP6	EP5	EP4	EP3	EP2	EP1	EP0						
USBRXIE, type R/W, offset 0x008, reset 0xFFFE (see page 1090)																	
				EP7	EP6	EP5	EP4	EP3	EP2	EP1							
USBIS, type RO, offset 0x00A, reset 0x00 (OTG A / Host Mode) (see page 1091)																	
								VBUSERR	SESREQ	DISCON	CONN	SOF	BABBLE	RESUME			
USBIS, type RO, offset 0x00A, reset 0x00 (OTG B / Device Mode) (see page 1091)																	
								DISCON			SOF	RESET	RESUME	SUSPEND			
USBIE, type R/W, offset 0x00B, reset 0x06 (OTG A / Host Mode) (see page 1094)																	
								VBUSERR	SESREQ	DISCON	CONN	SOF	BABBLE	RESUME			
USBIE, type R/W, offset 0x00B, reset 0x06 (OTG B / Device Mode) (see page 1094)																	
								DISCON			SOF	RESET	RESUME	SUSPEND			
USBFRAME, type RO, offset 0x00C, reset 0x0000 (see page 1097)																	
FRAME																	
USBEPIDX, type R/W, offset 0x00E, reset 0x00 (see page 1098)																	
EPIDX																	
USBTEST, type R/W, offset 0x00F, reset 0x00 (OTG A / Host Mode) (see page 1099)																	
								FORCEH	FIFOACC	FORCEFS							
USBTEST, type R/W, offset 0x00F, reset 0x00 (OTG B / Device Mode) (see page 1099)																	
								FIFOACC	FORCEFS								
USBFIFO0, type R/W, offset 0x020, reset 0x0000.0000 (see page 1101)																	
EPDATA																	
EPDATA																	
USBFIFO1, type R/W, offset 0x024, reset 0x0000.0000 (see page 1101)																	
EPDATA																	
EPDATA																	

31	30	29	28	27	26	25	24	23	22	21	20	19	18	17	16
15	14	13	12	11	10	9	8	7	6	5	4	3	2	1	0
USBFIFO2, type R/W, offset 0x028, reset 0x0000.0000 (see page 1101)															
EPDATA															
EPDATA															
USBFIFO3, type R/W, offset 0x02C, reset 0x0000.0000 (see page 1101)															
EPDATA															
EPDATA															
USBFIFO4, type R/W, offset 0x030, reset 0x0000.0000 (see page 1101)															
EPDATA															
EPDATA															
USBFIFO5, type R/W, offset 0x034, reset 0x0000.0000 (see page 1101)															
EPDATA															
EPDATA															
USBFIFO6, type R/W, offset 0x038, reset 0x0000.0000 (see page 1101)															
EPDATA															
EPDATA															
USBFIFO7, type R/W, offset 0x03C, reset 0x0000.0000 (see page 1101)															
EPDATA															
EPDATA															
USBDEVCTL, type R/W, offset 0x060, reset 0x80 (see page 1102)															
DEV FSDEV LSDEV VBUS HOST HOSTREQ SESSION															
USBTXFIFOSZ, type R/W, offset 0x062, reset 0x00 (see page 1104)															
DPB SIZE															
USBRXFIFOSZ, type R/W, offset 0x063, reset 0x00 (see page 1104)															
DPB SIZE															
USBTXFIFOADD, type R/W, offset 0x064, reset 0x0000 (see page 1105)															
ADDR															
USBRXFIFOADD, type R/W, offset 0x066, reset 0x0000 (see page 1105)															
ADDR															
USBCONTIM, type R/W, offset 0x07A, reset 0x5C (see page 1106)															
WTCON WTID															
USBVPLEN, type R/W, offset 0x07B, reset 0x3C (see page 1107)															
VPLEN															
USBFSEOF, type R/W, offset 0x07D, reset 0x77 (see page 1108)															
FSEOFG															
USBLSEOF, type R/W, offset 0x07E, reset 0x72 (see page 1109)															
LSEOFG															
USBTXFUNCADDR0, type R/W, offset 0x080, reset 0x00 (see page 1110)															
ADDR															
USBTXFUNCADDR1, type R/W, offset 0x088, reset 0x00 (see page 1110)															
ADDR															
USBTXFUNCADDR2, type R/W, offset 0x090, reset 0x00 (see page 1110)															
ADDR															
USBTXFUNCADDR3, type R/W, offset 0x098, reset 0x00 (see page 1110)															
ADDR															
USBTXFUNCADDR4, type R/W, offset 0x0A0, reset 0x00 (see page 1110)															
ADDR															
USBTXFUNCADDR5, type R/W, offset 0x0A8, reset 0x00 (see page 1110)															
ADDR															
USBTXFUNCADDR6, type R/W, offset 0x0B0, reset 0x00 (see page 1110)															
ADDR															
USBTXFUNCADDR7, type R/W, offset 0x0B8, reset 0x00 (see page 1110)															
ADDR															

31	30	29	28	27	26	25	24	23	22	21	20	19	18	17	16
15	14	13	12	11	10	9	8	7	6	5	4	3	2	1	0
USBTXHUBADDR0, type R/W, offset 0x082, reset 0x00 (see page 1111)															
												ADDR			
USBTXHUBADDR1, type R/W, offset 0x08A, reset 0x00 (see page 1111)															
												ADDR			
USBTXHUBADDR2, type R/W, offset 0x092, reset 0x00 (see page 1111)															
												ADDR			
USBTXHUBADDR3, type R/W, offset 0x09A, reset 0x00 (see page 1111)															
												ADDR			
USBTXHUBADDR4, type R/W, offset 0x0A2, reset 0x00 (see page 1111)															
												ADDR			
USBTXHUBADDR5, type R/W, offset 0x0AA, reset 0x00 (see page 1111)															
												ADDR			
USBTXHUBADDR6, type R/W, offset 0x0B2, reset 0x00 (see page 1111)															
												ADDR			
USBTXHUBADDR7, type R/W, offset 0x0BA, reset 0x00 (see page 1111)															
												ADDR			
USBTXHUBPORT0, type R/W, offset 0x083, reset 0x00 (see page 1112)															
												PORT			
USBTXHUBPORT1, type R/W, offset 0x08B, reset 0x00 (see page 1112)															
												PORT			
USBTXHUBPORT2, type R/W, offset 0x093, reset 0x00 (see page 1112)															
												PORT			
USBTXHUBPORT3, type R/W, offset 0x09B, reset 0x00 (see page 1112)															
												PORT			
USBTXHUBPORT4, type R/W, offset 0x0A3, reset 0x00 (see page 1112)															
												PORT			
USBTXHUBPORT5, type R/W, offset 0x0AB, reset 0x00 (see page 1112)															
												PORT			
USBTXHUBPORT6, type R/W, offset 0x0B3, reset 0x00 (see page 1112)															
												PORT			
USBTXHUBPORT7, type R/W, offset 0x0BB, reset 0x00 (see page 1112)															
												PORT			
USBRXFUNCADDR1, type R/W, offset 0x08C, reset 0x00 (see page 1113)															
												ADDR			
USBRXFUNCADDR2, type R/W, offset 0x094, reset 0x00 (see page 1113)															
												ADDR			
USBRXFUNCADDR3, type R/W, offset 0x09C, reset 0x00 (see page 1113)															
												ADDR			
USBRXFUNCADDR4, type R/W, offset 0x0A4, reset 0x00 (see page 1113)															
												ADDR			
USBRXFUNCADDR5, type R/W, offset 0x0AC, reset 0x00 (see page 1113)															
												ADDR			
USBRXFUNCADDR6, type R/W, offset 0x0B4, reset 0x00 (see page 1113)															
												ADDR			
USBRXFUNCADDR7, type R/W, offset 0x0BC, reset 0x00 (see page 1113)															
												ADDR			
USBRXHUBADDR1, type R/W, offset 0x08E, reset 0x00 (see page 1114)															
												ADDR			
USBRXHUBADDR2, type R/W, offset 0x096, reset 0x00 (see page 1114)															
												ADDR			
USBRXHUBADDR3, type R/W, offset 0x09E, reset 0x00 (see page 1114)															
												ADDR			

31	30	29	28	27	26	25	24	23	22	21	20	19	18	17	16
15	14	13	12	11	10	9	8	7	6	5	4	3	2	1	0
USBXHHUBADDR4, type R/W, offset 0x0A6, reset 0x00 (see page 1114)															
												ADDR			
USBXHHUBADDR5, type R/W, offset 0x0AE, reset 0x00 (see page 1114)															
												ADDR			
USBXHHUBADDR6, type R/W, offset 0x0B6, reset 0x00 (see page 1114)															
												ADDR			
USBXHHUBADDR7, type R/W, offset 0x0BE, reset 0x00 (see page 1114)															
												ADDR			
USBXHHUBPORT1, type R/W, offset 0x08F, reset 0x00 (see page 1115)															
												PORT			
USBXHHUBPORT2, type R/W, offset 0x097, reset 0x00 (see page 1115)															
												PORT			
USBXHHUBPORT3, type R/W, offset 0x09F, reset 0x00 (see page 1115)															
												PORT			
USBXHHUBPORT4, type R/W, offset 0x0A7, reset 0x00 (see page 1115)															
												PORT			
USBXHHUBPORT5, type R/W, offset 0x0AF, reset 0x00 (see page 1115)															
												PORT			
USBXHHUBPORT6, type R/W, offset 0x0B7, reset 0x00 (see page 1115)															
												PORT			
USBXHHUBPORT7, type R/W, offset 0x0BF, reset 0x00 (see page 1115)															
												PORT			
USBTXMAXP1, type R/W, offset 0x110, reset 0x0000 (see page 1116)															
												MAXLOAD			
USBTXMAXP2, type R/W, offset 0x120, reset 0x0000 (see page 1116)															
												MAXLOAD			
USBTXMAXP3, type R/W, offset 0x130, reset 0x0000 (see page 1116)															
												MAXLOAD			
USBTXMAXP4, type R/W, offset 0x140, reset 0x0000 (see page 1116)															
												MAXLOAD			
USBTXMAXP5, type R/W, offset 0x150, reset 0x0000 (see page 1116)															
												MAXLOAD			
USBTXMAXP6, type R/W, offset 0x160, reset 0x0000 (see page 1116)															
												MAXLOAD			
USBTXMAXP7, type R/W, offset 0x170, reset 0x0000 (see page 1116)															
												MAXLOAD			
USBCSRL0, type W1C, offset 0x102, reset 0x00 (OTG A / Host Mode) (see page 1117)															
								NAKTO	STATUS	REQPKT	ERROR	SETUP	STALLED	TXRDY	RXRDY
USBCSRL0, type W1C, offset 0x102, reset 0x00 (OTG B / Device Mode) (see page 1117)															
								SETENDC	RXRDYC	STALL	SETEND	DATAEND	STALLED	TXRDY	RXRDY
USBCSRH0, type W1C, offset 0x103, reset 0x00 (OTG A / Host Mode) (see page 1121)															
												DTWE	DT	FLUSH	
USBCSRH0, type W1C, offset 0x103, reset 0x00 (OTG B / Device Mode) (see page 1121)															
												FLUSH			
USBCOUNT0, type RO, offset 0x108, reset 0x00 (see page 1123)															
												COUNT			
USBTYP0, type R/W, offset 0x10A, reset 0x00 (see page 1124)															
												SPEED			
USBNAKLMT, type R/W, offset 0x10B, reset 0x00 (see page 1125)															
												NAKLMT			
USBTXCSRL1, type R/W, offset 0x112, reset 0x00 (OTG A / Host Mode) (see page 1126)															
								NAKTO	CLRDT	STALLED	SETUP	FLUSH	ERROR	FIFONE	TXRDY

31	30	29	28	27	26	25	24	23	22	21	20	19	18	17	16
15	14	13	12	11	10	9	8	7	6	5	4	3	2	1	0
USBTXCSRL2, type R/W, offset 0x122, reset 0x00 (OTG A / Host Mode) (see page 1126)															
								NAKTO	CLRDT	STALLED	SETUP	FLUSH	ERROR	FIFONE	TXRDY
USBTXCSRL3, type R/W, offset 0x132, reset 0x00 (OTG A / Host Mode) (see page 1126)															
								NAKTO	CLRDT	STALLED	SETUP	FLUSH	ERROR	FIFONE	TXRDY
USBTXCSRL4, type R/W, offset 0x142, reset 0x00 (OTG A / Host Mode) (see page 1126)															
								NAKTO	CLRDT	STALLED	SETUP	FLUSH	ERROR	FIFONE	TXRDY
USBTXCSRL5, type R/W, offset 0x152, reset 0x00 (OTG A / Host Mode) (see page 1126)															
								NAKTO	CLRDT	STALLED	SETUP	FLUSH	ERROR	FIFONE	TXRDY
USBTXCSRL6, type R/W, offset 0x162, reset 0x00 (OTG A / Host Mode) (see page 1126)															
								NAKTO	CLRDT	STALLED	SETUP	FLUSH	ERROR	FIFONE	TXRDY
USBTXCSRL7, type R/W, offset 0x172, reset 0x00 (OTG A / Host Mode) (see page 1126)															
								NAKTO	CLRDT	STALLED	SETUP	FLUSH	ERROR	FIFONE	TXRDY
USBTXCSR1, type R/W, offset 0x112, reset 0x00 (OTG B / Device Mode) (see page 1126)															
									CLRDT	STALLED	STALL	FLUSH	UNDRN	FIFONE	TXRDY
USBTXCSR2, type R/W, offset 0x122, reset 0x00 (OTG B / Device Mode) (see page 1126)															
									CLRDT	STALLED	STALL	FLUSH	UNDRN	FIFONE	TXRDY
USBTXCSR3, type R/W, offset 0x132, reset 0x00 (OTG B / Device Mode) (see page 1126)															
									CLRDT	STALLED	STALL	FLUSH	UNDRN	FIFONE	TXRDY
USBTXCSR4, type R/W, offset 0x142, reset 0x00 (OTG B / Device Mode) (see page 1126)															
									CLRDT	STALLED	STALL	FLUSH	UNDRN	FIFONE	TXRDY
USBTXCSR5, type R/W, offset 0x152, reset 0x00 (OTG B / Device Mode) (see page 1126)															
									CLRDT	STALLED	STALL	FLUSH	UNDRN	FIFONE	TXRDY
USBTXCSR6, type R/W, offset 0x162, reset 0x00 (OTG B / Device Mode) (see page 1126)															
									CLRDT	STALLED	STALL	FLUSH	UNDRN	FIFONE	TXRDY
USBTXCSR7, type R/W, offset 0x172, reset 0x00 (OTG B / Device Mode) (see page 1126)															
									CLRDT	STALLED	STALL	FLUSH	UNDRN	FIFONE	TXRDY
USBTXCSRH1, type R/W, offset 0x113, reset 0x00 (OTG A / Host Mode) (see page 1130)															
								AUTOSET		MODE	DMAEN	FDT	DMAMOD	DTWE	DT
USBTXCSRH2, type R/W, offset 0x123, reset 0x00 (OTG A / Host Mode) (see page 1130)															
								AUTOSET		MODE	DMAEN	FDT	DMAMOD	DTWE	DT
USBTXCSRH3, type R/W, offset 0x133, reset 0x00 (OTG A / Host Mode) (see page 1130)															
								AUTOSET		MODE	DMAEN	FDT	DMAMOD	DTWE	DT
USBTXCSRH4, type R/W, offset 0x143, reset 0x00 (OTG A / Host Mode) (see page 1130)															
								AUTOSET		MODE	DMAEN	FDT	DMAMOD	DTWE	DT
USBTXCSRH5, type R/W, offset 0x153, reset 0x00 (OTG A / Host Mode) (see page 1130)															
								AUTOSET		MODE	DMAEN	FDT	DMAMOD	DTWE	DT
USBTXCSRH6, type R/W, offset 0x163, reset 0x00 (OTG A / Host Mode) (see page 1130)															
								AUTOSET		MODE	DMAEN	FDT	DMAMOD	DTWE	DT
USBTXCSRH7, type R/W, offset 0x173, reset 0x00 (OTG A / Host Mode) (see page 1130)															
								AUTOSET		MODE	DMAEN	FDT	DMAMOD	DTWE	DT
USBTXCSRH1, type R/W, offset 0x113, reset 0x00 (OTG B / Device Mode) (see page 1130)															
								AUTOSET	ISO	MODE	DMAEN	FDT	DMAMOD		
USBTXCSRH2, type R/W, offset 0x123, reset 0x00 (OTG B / Device Mode) (see page 1130)															
								AUTOSET	ISO	MODE	DMAEN	FDT	DMAMOD		
USBTXCSRH3, type R/W, offset 0x133, reset 0x00 (OTG B / Device Mode) (see page 1130)															
								AUTOSET	ISO	MODE	DMAEN	FDT	DMAMOD		
USBTXCSRH4, type R/W, offset 0x143, reset 0x00 (OTG B / Device Mode) (see page 1130)															
								AUTOSET	ISO	MODE	DMAEN	FDT	DMAMOD		
USBTXCSRH5, type R/W, offset 0x153, reset 0x00 (OTG B / Device Mode) (see page 1130)															
								AUTOSET	ISO	MODE	DMAEN	FDT	DMAMOD		
USBTXCSRH6, type R/W, offset 0x163, reset 0x00 (OTG B / Device Mode) (see page 1130)															
								AUTOSET	ISO	MODE	DMAEN	FDT	DMAMOD		

31	30	29	28	27	26	25	24	23	22	21	20	19	18	17	16
15	14	13	12	11	10	9	8	7	6	5	4	3	2	1	0
USBTXCSRH7, type R/W, offset 0x173, reset 0x00 (OTG B / Device Mode) (see page 1130)															
								AUTOSET	ISO	MODE	DMAEN	FDT	DMAMOD		
USBRXMAXP1, type R/W, offset 0x114, reset 0x0000 (see page 1134)															
								MAXLOAD							
USBRXMAXP2, type R/W, offset 0x124, reset 0x0000 (see page 1134)															
								MAXLOAD							
USBRXMAXP3, type R/W, offset 0x134, reset 0x0000 (see page 1134)															
								MAXLOAD							
USBRXMAXP4, type R/W, offset 0x144, reset 0x0000 (see page 1134)															
								MAXLOAD							
USBRXMAXP5, type R/W, offset 0x154, reset 0x0000 (see page 1134)															
								MAXLOAD							
USBRXMAXP6, type R/W, offset 0x164, reset 0x0000 (see page 1134)															
								MAXLOAD							
USBRXMAXP7, type R/W, offset 0x174, reset 0x0000 (see page 1134)															
								MAXLOAD							
USBRXCSRL1, type R/W, offset 0x116, reset 0x00 (OTG A / Host Mode) (see page 1135)															
								CLRDT	STALLED	REQPKT	FLUSH	DATAERR / NAKTO	ERROR	FULL	RXRDY
USBRXCSRL2, type R/W, offset 0x126, reset 0x00 (OTG A / Host Mode) (see page 1135)															
								CLRDT	STALLED	REQPKT	FLUSH	DATAERR / NAKTO	ERROR	FULL	RXRDY
USBRXCSRL3, type R/W, offset 0x136, reset 0x00 (OTG A / Host Mode) (see page 1135)															
								CLRDT	STALLED	REQPKT	FLUSH	DATAERR / NAKTO	ERROR	FULL	RXRDY
USBRXCSRL4, type R/W, offset 0x146, reset 0x00 (OTG A / Host Mode) (see page 1135)															
								CLRDT	STALLED	REQPKT	FLUSH	DATAERR / NAKTO	ERROR	FULL	RXRDY
USBRXCSRL5, type R/W, offset 0x156, reset 0x00 (OTG A / Host Mode) (see page 1135)															
								CLRDT	STALLED	REQPKT	FLUSH	DATAERR / NAKTO	ERROR	FULL	RXRDY
USBRXCSRL6, type R/W, offset 0x166, reset 0x00 (OTG A / Host Mode) (see page 1135)															
								CLRDT	STALLED	REQPKT	FLUSH	DATAERR / NAKTO	ERROR	FULL	RXRDY
USBRXCSRL7, type R/W, offset 0x176, reset 0x00 (OTG A / Host Mode) (see page 1135)															
								CLRDT	STALLED	REQPKT	FLUSH	DATAERR / NAKTO	ERROR	FULL	RXRDY
USBRXCSRL1, type R/W, offset 0x116, reset 0x00 (OTG B / Device Mode) (see page 1135)															
								CLRDT	STALLED	STALL	FLUSH	DATAERR	OVER	FULL	RXRDY
USBRXCSRL2, type R/W, offset 0x126, reset 0x00 (OTG B / Device Mode) (see page 1135)															
								CLRDT	STALLED	STALL	FLUSH	DATAERR	OVER	FULL	RXRDY
USBRXCSRL3, type R/W, offset 0x136, reset 0x00 (OTG B / Device Mode) (see page 1135)															
								CLRDT	STALLED	STALL	FLUSH	DATAERR	OVER	FULL	RXRDY
USBRXCSRL4, type R/W, offset 0x146, reset 0x00 (OTG B / Device Mode) (see page 1135)															
								CLRDT	STALLED	STALL	FLUSH	DATAERR	OVER	FULL	RXRDY
USBRXCSRL5, type R/W, offset 0x156, reset 0x00 (OTG B / Device Mode) (see page 1135)															
								CLRDT	STALLED	STALL	FLUSH	DATAERR	OVER	FULL	RXRDY
USBRXCSRL6, type R/W, offset 0x166, reset 0x00 (OTG B / Device Mode) (see page 1135)															
								CLRDT	STALLED	STALL	FLUSH	DATAERR	OVER	FULL	RXRDY
USBRXCSRL7, type R/W, offset 0x176, reset 0x00 (OTG B / Device Mode) (see page 1135)															
								CLRDT	STALLED	STALL	FLUSH	DATAERR	OVER	FULL	RXRDY
USBRXCSRH1, type R/W, offset 0x117, reset 0x00 (OTG A / Host Mode) (see page 1140)															
								AUTOCL	AUTORQ	DMAEN	PIDERR	DMAMOD	DTWE	DT	
USBRXCSRH2, type R/W, offset 0x127, reset 0x00 (OTG A / Host Mode) (see page 1140)															
								AUTOCL	AUTORQ	DMAEN	PIDERR	DMAMOD	DTWE	DT	

31	30	29	28	27	26	25	24	23	22	21	20	19	18	17	16
15	14	13	12	11	10	9	8	7	6	5	4	3	2	1	0
USBRXCSRH3, type R/W, offset 0x137, reset 0x00 (OTG A / Host Mode) (see page 1140)															
								AUTOCL	AUTORQ	DMAEN	PIDERR	DMAMOD	DTWE	DT	
USBRXCSRH4, type R/W, offset 0x147, reset 0x00 (OTG A / Host Mode) (see page 1140)															
								AUTOCL	AUTORQ	DMAEN	PIDERR	DMAMOD	DTWE	DT	
USBRXCSRH5, type R/W, offset 0x157, reset 0x00 (OTG A / Host Mode) (see page 1140)															
								AUTOCL	AUTORQ	DMAEN	PIDERR	DMAMOD	DTWE	DT	
USBRXCSRH6, type R/W, offset 0x167, reset 0x00 (OTG A / Host Mode) (see page 1140)															
								AUTOCL	AUTORQ	DMAEN	PIDERR	DMAMOD	DTWE	DT	
USBRXCSRH7, type R/W, offset 0x177, reset 0x00 (OTG A / Host Mode) (see page 1140)															
								AUTOCL	AUTORQ	DMAEN	PIDERR	DMAMOD	DTWE	DT	
USBRXCSRH1, type R/W, offset 0x117, reset 0x00 (OTG B / Device Mode) (see page 1140)															
								AUTOCL	ISO	DMAEN	DISNYET / PIDERR	DMAMOD			
USBRXCSRH2, type R/W, offset 0x127, reset 0x00 (OTG B / Device Mode) (see page 1140)															
								AUTOCL	ISO	DMAEN	DISNYET / PIDERR	DMAMOD			
USBRXCSRH3, type R/W, offset 0x137, reset 0x00 (OTG B / Device Mode) (see page 1140)															
								AUTOCL	ISO	DMAEN	DISNYET / PIDERR	DMAMOD			
USBRXCSRH4, type R/W, offset 0x147, reset 0x00 (OTG B / Device Mode) (see page 1140)															
								AUTOCL	ISO	DMAEN	DISNYET / PIDERR	DMAMOD			
USBRXCSRH5, type R/W, offset 0x157, reset 0x00 (OTG B / Device Mode) (see page 1140)															
								AUTOCL	ISO	DMAEN	DISNYET / PIDERR	DMAMOD			
USBRXCSRH6, type R/W, offset 0x167, reset 0x00 (OTG B / Device Mode) (see page 1140)															
								AUTOCL	ISO	DMAEN	DISNYET / PIDERR	DMAMOD			
USBRXCSRH7, type R/W, offset 0x177, reset 0x00 (OTG B / Device Mode) (see page 1140)															
								AUTOCL	ISO	DMAEN	DISNYET / PIDERR	DMAMOD			
USBRXCOUNT1, type RO, offset 0x118, reset 0x0000 (see page 1144)															
								COUNT							
USBRXCOUNT2, type RO, offset 0x128, reset 0x0000 (see page 1144)															
								COUNT							
USBRXCOUNT3, type RO, offset 0x138, reset 0x0000 (see page 1144)															
								COUNT							
USBRXCOUNT4, type RO, offset 0x148, reset 0x0000 (see page 1144)															
								COUNT							
USBRXCOUNT5, type RO, offset 0x158, reset 0x0000 (see page 1144)															
								COUNT							
USBRXCOUNT6, type RO, offset 0x168, reset 0x0000 (see page 1144)															
								COUNT							
USBRXCOUNT7, type RO, offset 0x178, reset 0x0000 (see page 1144)															
								COUNT							
USBTXTYPE1, type R/W, offset 0x11A, reset 0x00 (see page 1145)															
								SPEED		PROTO		TEP			
USBTXTYPE2, type R/W, offset 0x12A, reset 0x00 (see page 1145)															
								SPEED		PROTO		TEP			
USBTXTYPE3, type R/W, offset 0x13A, reset 0x00 (see page 1145)															
								SPEED		PROTO		TEP			
USBTXTYPE4, type R/W, offset 0x14A, reset 0x00 (see page 1145)															
								SPEED		PROTO		TEP			
USBTXTYPE5, type R/W, offset 0x15A, reset 0x00 (see page 1145)															
								SPEED		PROTO		TEP			

31	30	29	28	27	26	25	24	23	22	21	20	19	18	17	16
15	14	13	12	11	10	9	8	7	6	5	4	3	2	1	0
USBTXTYPE6, type R/W, offset 0x16A, reset 0x00 (see page 1145)															
								SPEED		PROTO		TEP			
USBTXTYPE7, type R/W, offset 0x17A, reset 0x00 (see page 1145)															
								SPEED		PROTO		TEP			
USBTXINTERVAL1, type R/W, offset 0x11B, reset 0x00 (see page 1147)															
												TXPOLL / NAKLMT			
USBTXINTERVAL2, type R/W, offset 0x12B, reset 0x00 (see page 1147)															
												TXPOLL / NAKLMT			
USBTXINTERVAL3, type R/W, offset 0x13B, reset 0x00 (see page 1147)															
												TXPOLL / NAKLMT			
USBTXINTERVAL4, type R/W, offset 0x14B, reset 0x00 (see page 1147)															
												TXPOLL / NAKLMT			
USBTXINTERVAL5, type R/W, offset 0x15B, reset 0x00 (see page 1147)															
												TXPOLL / NAKLMT			
USBTXINTERVAL6, type R/W, offset 0x16B, reset 0x00 (see page 1147)															
												TXPOLL / NAKLMT			
USBTXINTERVAL7, type R/W, offset 0x17B, reset 0x00 (see page 1147)															
												TXPOLL / NAKLMT			
USBRXTYPE1, type R/W, offset 0x11C, reset 0x00 (see page 1148)															
								SPEED		PROTO		TEP			
USBRXTYPE2, type R/W, offset 0x12C, reset 0x00 (see page 1148)															
								SPEED		PROTO		TEP			
USBRXTYPE3, type R/W, offset 0x13C, reset 0x00 (see page 1148)															
								SPEED		PROTO		TEP			
USBRXTYPE4, type R/W, offset 0x14C, reset 0x00 (see page 1148)															
								SPEED		PROTO		TEP			
USBRXTYPE5, type R/W, offset 0x15C, reset 0x00 (see page 1148)															
								SPEED		PROTO		TEP			
USBRXTYPE6, type R/W, offset 0x16C, reset 0x00 (see page 1148)															
								SPEED		PROTO		TEP			
USBRXTYPE7, type R/W, offset 0x17C, reset 0x00 (see page 1148)															
								SPEED		PROTO		TEP			
USBRXINTERVAL1, type R/W, offset 0x11D, reset 0x00 (see page 1150)															
												TXPOLL / NAKLMT			
USBRXINTERVAL2, type R/W, offset 0x12D, reset 0x00 (see page 1150)															
												TXPOLL / NAKLMT			
USBRXINTERVAL3, type R/W, offset 0x13D, reset 0x00 (see page 1150)															
												TXPOLL / NAKLMT			
USBRXINTERVAL4, type R/W, offset 0x14D, reset 0x00 (see page 1150)															
												TXPOLL / NAKLMT			
USBRXINTERVAL5, type R/W, offset 0x15D, reset 0x00 (see page 1150)															
												TXPOLL / NAKLMT			
USBRXINTERVAL6, type R/W, offset 0x16D, reset 0x00 (see page 1150)															
												TXPOLL / NAKLMT			
USBRXINTERVAL7, type R/W, offset 0x17D, reset 0x00 (see page 1150)															
												TXPOLL / NAKLMT			
USBRQPKTCOUNT1, type R/W, offset 0x304, reset 0x0000 (see page 1151)															
												COUNT			
USBRQPKTCOUNT2, type R/W, offset 0x308, reset 0x0000 (see page 1151)															
												COUNT			
USBRQPKTCOUNT3, type R/W, offset 0x30C, reset 0x0000 (see page 1151)															
												COUNT			

31	30	29	28	27	26	25	24	23	22	21	20	19	18	17	16	
15	14	13	12	11	10	9	8	7	6	5	4	3	2	1	0	
USBQPKTCOUNT4, type R/W, offset 0x310, reset 0x0000 (see page 1151)																
COUNT																
USBQPKTCOUNT5, type R/W, offset 0x314, reset 0x0000 (see page 1151)																
COUNT																
USBQPKTCOUNT6, type R/W, offset 0x318, reset 0x0000 (see page 1151)																
COUNT																
USBQPKTCOUNT7, type R/W, offset 0x31C, reset 0x0000 (see page 1151)																
COUNT																
USBXDPKTBUFDIS, type R/W, offset 0x340, reset 0x0000 (see page 1152)																
								EP7	EP6	EP5	EP4	EP3	EP2	EP1		
USBTXDPKTBUFDIS, type R/W, offset 0x342, reset 0x0000 (see page 1153)																
								EP7	EP6	EP5	EP4	EP3	EP2	EP1		
USBEPIC, type R/W, offset 0x400, reset 0x0000.0000 (see page 1154)																
						PFLTACT				PFLTAEN	PFLTSEN	PFLTEN			EPENDE	EPEN
USBEPICRIS, type RO, offset 0x404, reset 0x0000.0000 (see page 1157)																
															PF	
USBEPICIM, type R/W, offset 0x408, reset 0x0000.0000 (see page 1158)																
															PF	
USBEPICISC, type R/W, offset 0x40C, reset 0x0000.0000 (see page 1159)																
															PF	
USBDRRIS, type RO, offset 0x410, reset 0x0000.0000 (see page 1160)																
															RESUME	
USBDRIM, type R/W, offset 0x414, reset 0x0000.0000 (see page 1161)																
															RESUME	
USBDRISC, type W1C, offset 0x418, reset 0x0000.0000 (see page 1162)																
															RESUME	
USBGPCS, type R/W, offset 0x41C, reset 0x0000.0003 (see page 1163)																
														DEVMODTG	DEVMOD	
USBVDC, type R/W, offset 0x430, reset 0x0000.0000 (see page 1164)																
															VB DEN	
USBVDCRIS, type RO, offset 0x434, reset 0x0000.0000 (see page 1165)																
															VD	
USBVDCIM, type R/W, offset 0x438, reset 0x0000.0000 (see page 1166)																
															VD	
USBVDCISC, type R/W, offset 0x43C, reset 0x0000.0000 (see page 1167)																
															VD	
USBIDVRIS, type RO, offset 0x444, reset 0x0000.0000 (see page 1168)																
															ID	

31	30	29	28	27	26	25	24	23	22	21	20	19	18	17	16
15	14	13	12	11	10	9	8	7	6	5	4	3	2	1	0
USBIDVIM, type R/W, offset 0x448, reset 0x0000.0000 (see page 1169)															
															ID
USBIDVISC, type R/W1C, offset 0x44C, reset 0x0000.0000 (see page 1170)															
															ID
USBDMASEL, type R/W, offset 0x450, reset 0x0033.2211 (see page 1171)															
DMABTX				DMABRX				DMACTX				DMACRX			
								DMAATX				DMAARX			
USBPP, type RO, offset 0xFC0, reset 0x0000.10D0 (see page 1173)															
ECNT						USB			PHY		TYPE				
Analog Comparators															
Base 0x4003.C000															
ACMIS, type R/W1C, offset 0x000, reset 0x0000.0000 (see page 1181)															
														IN1	IN0
ACRIS, type RO, offset 0x004, reset 0x0000.0000 (see page 1182)															
														IN1	IN0
ACINTEN, type R/W, offset 0x008, reset 0x0000.0000 (see page 1183)															
														IN1	IN0
ACREFCTL, type R/W, offset 0x010, reset 0x0000.0000 (see page 1184)															
						EN	RNG							VREF	
ACSTAT0, type RO, offset 0x020, reset 0x0000.0000 (see page 1185)															
														OVAL	
ACSTAT1, type RO, offset 0x040, reset 0x0000.0000 (see page 1185)															
														OVAL	
ACCTL0, type R/W, offset 0x024, reset 0x0000.0000 (see page 1186)															
				TOEN	ASRCP			TSLVAL	TSEN	ISLVAL	ISEN	CINV			
ACCTL1, type R/W, offset 0x044, reset 0x0000.0000 (see page 1186)															
				TOEN	ASRCP			TSLVAL	TSEN	ISLVAL	ISEN	CINV			
ACMPPP, type RO, offset 0xFC0, reset 0x0003.0003 (see page 1188)															
														C10	C00
														CMP1	CMP0
Pulse Width Modulator (PWM)															
PWM0 base: 0x4002.8000															
PWM1 base: 0x4002.9000															
PWMCTL, type R/W, offset 0x000, reset 0x0000.0000 (see page 1203)															
												GLOBALSYNC3	GLOBALSYNC2	GLOBALSYNC1	GLOBALSYNC0
PWMSYNC, type R/W, offset 0x004, reset 0x0000.0000 (see page 1205)															
												SYNC3	SYNC2	SYNC1	SYNC0
PWMENABLE, type R/W, offset 0x008, reset 0x0000.0000 (see page 1206)															
								PWM7EN	PWM6EN	PWM5EN	PWM4EN	PWM3EN	PWM2EN	PWM1EN	PWM0EN

31	30	29	28	27	26	25	24	23	22	21	20	19	18	17	16		
15	14	13	12	11	10	9	8	7	6	5	4	3	2	1	0		
PWMINVERT , type R/W, offset 0x00C, reset 0x0000.0000 (see page 1208)																	
										PWM7INV	PWM6INV	PWM5INV	PWM4INV	PWM3INV	PWM2INV	PWM1INV	PWM0INV
PWMFAULT , type R/W, offset 0x010, reset 0x0000.0000 (see page 1210)																	
										FAULT7	FAULT6	FAULT5	FAULT4	FAULT3	FAULT2	FAULT1	FAULT0
PWMINTEN , type R/W, offset 0x014, reset 0x0000.0000 (see page 1212)																	
														INTFAULT3	INTFAULT2	INTFAULT1	INTFAULT0
														INTPWM3	INTPWM2	INTPWM1	INTPWM0
PWMRIS , type RO, offset 0x018, reset 0x0000.0000 (see page 1214)																	
														INTFAULT3	INTFAULT2	INTFAULT1	INTFAULT0
														INTPWM3	INTPWM2	INTPWM1	INTPWM0
PWMISC , type R/W1C, offset 0x01C, reset 0x0000.0000 (see page 1217)																	
														INTFAULT3	INTFAULT2	INTFAULT1	INTFAULT0
														INTPWM3	INTPWM2	INTPWM1	INTPWM0
PWMSTATUS , type RO, offset 0x020, reset 0x0000.0000 (see page 1220)																	
														FAULT3	FAULT2	FAULT1	FAULT0
PWMFAULTVAL , type R/W, offset 0x024, reset 0x0000.0000 (see page 1222)																	
										PWM7	PWM6	PWM5	PWM4	PWM3	PWM2	PWM1	PWM0
PWMENUPD , type R/W, offset 0x028, reset 0x0000.0000 (see page 1224)																	
	ENUPD7	ENUPD6	ENUPD5	ENUPD4	ENUPD3	ENUPD2	ENUPD1	ENUPD0									
PWM0CTL , type R/W, offset 0x040, reset 0x0000.0000 (see page 1228)																	
														LATCH	MINFLTPER	FLTSRC	
	DBFALLUPD	DRISEUPD	DBCTLUPD	GENBUPD	GENAUPD	CMPBUPD	CMPAUPD	LOADUPD	DEBUG	MODE	ENABLE						
PWM1CTL , type R/W, offset 0x080, reset 0x0000.0000 (see page 1228)																	
														LATCH	MINFLTPER	FLTSRC	
	DBFALLUPD	DRISEUPD	DBCTLUPD	GENBUPD	GENAUPD	CMPBUPD	CMPAUPD	LOADUPD	DEBUG	MODE	ENABLE						
PWM2CTL , type R/W, offset 0x0C0, reset 0x0000.0000 (see page 1228)																	
														LATCH	MINFLTPER	FLTSRC	
	DBFALLUPD	DRISEUPD	DBCTLUPD	GENBUPD	GENAUPD	CMPBUPD	CMPAUPD	LOADUPD	DEBUG	MODE	ENABLE						
PWM3CTL , type R/W, offset 0x100, reset 0x0000.0000 (see page 1228)																	
														LATCH	MINFLTPER	FLTSRC	
	DBFALLUPD	DRISEUPD	DBCTLUPD	GENBUPD	GENAUPD	CMPBUPD	CMPAUPD	LOADUPD	DEBUG	MODE	ENABLE						
PWM0INTEN , type R/W, offset 0x044, reset 0x0000.0000 (see page 1233)																	
		TRCMPBD	TRCMPBU	TRCMPAD	TRCMPAU	TRCNTLOAD	TRCNTZERO			INTCMPBD	INTCMPBU	INTCMPAD	INTCMPAU	INTCNTLOAD	INTCNTZERO		
PWM1INTEN , type R/W, offset 0x084, reset 0x0000.0000 (see page 1233)																	
		TRCMPBD	TRCMPBU	TRCMPAD	TRCMPAU	TRCNTLOAD	TRCNTZERO			INTCMPBD	INTCMPBU	INTCMPAD	INTCMPAU	INTCNTLOAD	INTCNTZERO		
PWM2INTEN , type R/W, offset 0x0C4, reset 0x0000.0000 (see page 1233)																	
		TRCMPBD	TRCMPBU	TRCMPAD	TRCMPAU	TRCNTLOAD	TRCNTZERO			INTCMPBD	INTCMPBU	INTCMPAD	INTCMPAU	INTCNTLOAD	INTCNTZERO		
PWM3INTEN , type R/W, offset 0x104, reset 0x0000.0000 (see page 1233)																	
		TRCMPBD	TRCMPBU	TRCMPAD	TRCMPAU	TRCNTLOAD	TRCNTZERO			INTCMPBD	INTCMPBU	INTCMPAD	INTCMPAU	INTCNTLOAD	INTCNTZERO		
PWM0RIS , type RO, offset 0x048, reset 0x0000.0000 (see page 1236)																	
										INTCMPBD	INTCMPBU	INTCMPAD	INTCMPAU	INTCNTLOAD	INTCNTZERO		

31	30	29	28	27	26	25	24	23	22	21	20	19	18	17	16
15	14	13	12	11	10	9	8	7	6	5	4	3	2	1	0
PWM2CMPA, type R/W, offset 0x0D8, reset 0x0000.0000 (see page 1242)															
COMPA															
PWM3CMPA, type R/W, offset 0x118, reset 0x0000.0000 (see page 1242)															
COMPA															
PWM0CMPB, type R/W, offset 0x05C, reset 0x0000.0000 (see page 1243)															
COMPB															
PWM1CMPB, type R/W, offset 0x09C, reset 0x0000.0000 (see page 1243)															
COMPB															
PWM2CMPB, type R/W, offset 0x0DC, reset 0x0000.0000 (see page 1243)															
COMPB															
PWM3CMPB, type R/W, offset 0x11C, reset 0x0000.0000 (see page 1243)															
COMPB															
PWM0GENA, type R/W, offset 0x060, reset 0x0000.0000 (see page 1244)															
				ACTCMPBD		ACTCMPBU		ACTCMPAD		ACTCMPAU		ACTLOAD		ACTZERO	
PWM1GENA, type R/W, offset 0x0A0, reset 0x0000.0000 (see page 1244)															
				ACTCMPBD		ACTCMPBU		ACTCMPAD		ACTCMPAU		ACTLOAD		ACTZERO	
PWM2GENA, type R/W, offset 0x0E0, reset 0x0000.0000 (see page 1244)															
				ACTCMPBD		ACTCMPBU		ACTCMPAD		ACTCMPAU		ACTLOAD		ACTZERO	
PWM3GENA, type R/W, offset 0x120, reset 0x0000.0000 (see page 1244)															
				ACTCMPBD		ACTCMPBU		ACTCMPAD		ACTCMPAU		ACTLOAD		ACTZERO	
PWM0GENB, type R/W, offset 0x064, reset 0x0000.0000 (see page 1247)															
				ACTCMPBD		ACTCMPBU		ACTCMPAD		ACTCMPAU		ACTLOAD		ACTZERO	
PWM1GENB, type R/W, offset 0x0A4, reset 0x0000.0000 (see page 1247)															
				ACTCMPBD		ACTCMPBU		ACTCMPAD		ACTCMPAU		ACTLOAD		ACTZERO	
PWM2GENB, type R/W, offset 0x0E4, reset 0x0000.0000 (see page 1247)															
				ACTCMPBD		ACTCMPBU		ACTCMPAD		ACTCMPAU		ACTLOAD		ACTZERO	
PWM3GENB, type R/W, offset 0x124, reset 0x0000.0000 (see page 1247)															
				ACTCMPBD		ACTCMPBU		ACTCMPAD		ACTCMPAU		ACTLOAD		ACTZERO	
PWM0DBCTL, type R/W, offset 0x068, reset 0x0000.0000 (see page 1250)															
														ENABLE	
PWM1DBCTL, type R/W, offset 0x0A8, reset 0x0000.0000 (see page 1250)															
														ENABLE	
PWM2DBCTL, type R/W, offset 0x0E8, reset 0x0000.0000 (see page 1250)															
														ENABLE	

31	30	29	28	27	26	25	24	23	22	21	20	19	18	17	16	
15	14	13	12	11	10	9	8	7	6	5	4	3	2	1	0	
PWM3DBCTL, type R/W, offset 0x128, reset 0x0000.0000 (see page 1250)																
															ENABLE	
PWM0DBRISE, type R/W, offset 0x06C, reset 0x0000.0000 (see page 1251)																
															RISEDELAY	
PWM1DBRISE, type R/W, offset 0x0AC, reset 0x0000.0000 (see page 1251)																
															RISEDELAY	
PWM2DBRISE, type R/W, offset 0x0EC, reset 0x0000.0000 (see page 1251)																
															RISEDELAY	
PWM3DBRISE, type R/W, offset 0x12C, reset 0x0000.0000 (see page 1251)																
															RISEDELAY	
PWM0DBFALL, type R/W, offset 0x070, reset 0x0000.0000 (see page 1252)																
															FALLDELAY	
PWM1DBFALL, type R/W, offset 0x0B0, reset 0x0000.0000 (see page 1252)																
															FALLDELAY	
PWM2DBFALL, type R/W, offset 0x0F0, reset 0x0000.0000 (see page 1252)																
															FALLDELAY	
PWM3DBFALL, type R/W, offset 0x130, reset 0x0000.0000 (see page 1252)																
															FALLDELAY	
PWM0FLTSRC0, type R/W, offset 0x074, reset 0x0000.0000 (see page 1253)																
													FAULT3	FAULT2	FAULT1	FAULT0
PWM1FLTSRC0, type R/W, offset 0x0B4, reset 0x0000.0000 (see page 1253)																
													FAULT3	FAULT2	FAULT1	FAULT0
PWM2FLTSRC0, type R/W, offset 0x0F4, reset 0x0000.0000 (see page 1253)																
													FAULT3	FAULT2	FAULT1	FAULT0
PWM3FLTSRC0, type R/W, offset 0x134, reset 0x0000.0000 (see page 1253)																
													FAULT3	FAULT2	FAULT1	FAULT0
PWM0FLTSRC1, type R/W, offset 0x078, reset 0x0000.0000 (see page 1255)																
									DCMP7	DCMP6	DCMP5	DCMP4	DCMP3	DCMP2	DCMP1	DCMP0
PWM1FLTSRC1, type R/W, offset 0x0B8, reset 0x0000.0000 (see page 1255)																
									DCMP7	DCMP6	DCMP5	DCMP4	DCMP3	DCMP2	DCMP1	DCMP0
PWM2FLTSRC1, type R/W, offset 0x0F8, reset 0x0000.0000 (see page 1255)																
									DCMP7	DCMP6	DCMP5	DCMP4	DCMP3	DCMP2	DCMP1	DCMP0
PWM3FLTSRC1, type R/W, offset 0x138, reset 0x0000.0000 (see page 1255)																
									DCMP7	DCMP6	DCMP5	DCMP4	DCMP3	DCMP2	DCMP1	DCMP0

31	30	29	28	27	26	25	24	23	22	21	20	19	18	17	16
15	14	13	12	11	10	9	8	7	6	5	4	3	2	1	0
PWM0MINFLTPER, type R/W, offset 0x07C, reset 0x0000.0000 (see page 1258)															
MFP															
PWM1MINFLTPER, type R/W, offset 0x0BC, reset 0x0000.0000 (see page 1258)															
MFP															
PWM2MINFLTPER, type R/W, offset 0x0FC, reset 0x0000.0000 (see page 1258)															
MFP															
PWM3MINFLTPER, type R/W, offset 0x13C, reset 0x0000.0000 (see page 1258)															
MFP															
PWM0FLTSEN, type R/W, offset 0x800, reset 0x0000.0000 (see page 1259)															
												FAULT3	FAULT2	FAULT1	FAULT0
PWM1FLTSEN, type R/W, offset 0x880, reset 0x0000.0000 (see page 1259)															
												FAULT3	FAULT2	FAULT1	FAULT0
PWM2FLTSEN, type R/W, offset 0x900, reset 0x0000.0000 (see page 1259)															
												FAULT3	FAULT2	FAULT1	FAULT0
PWM3FLTSEN, type R/W, offset 0x980, reset 0x0000.0000 (see page 1259)															
												FAULT3	FAULT2	FAULT1	FAULT0
PWM0FLTSTAT0, type -, offset 0x804, reset 0x0000.0000 (see page 1260)															
												FAULT3	FAULT2	FAULT1	FAULT0
PWM1FLTSTAT0, type -, offset 0x884, reset 0x0000.0000 (see page 1260)															
												FAULT3	FAULT2	FAULT1	FAULT0
PWM2FLTSTAT0, type -, offset 0x904, reset 0x0000.0000 (see page 1260)															
												FAULT3	FAULT2	FAULT1	FAULT0
PWM3FLTSTAT0, type -, offset 0x984, reset 0x0000.0000 (see page 1260)															
												FAULT3	FAULT2	FAULT1	FAULT0
PWM0FLTSTAT1, type -, offset 0x808, reset 0x0000.0000 (see page 1262)															
								DCMP7	DCMP6	DCMP5	DCMP4	DCMP3	DCMP2	DCMP1	DCMP0
PWM1FLTSTAT1, type -, offset 0x888, reset 0x0000.0000 (see page 1262)															
								DCMP7	DCMP6	DCMP5	DCMP4	DCMP3	DCMP2	DCMP1	DCMP0
PWM2FLTSTAT1, type -, offset 0x908, reset 0x0000.0000 (see page 1262)															
								DCMP7	DCMP6	DCMP5	DCMP4	DCMP3	DCMP2	DCMP1	DCMP0
PWM3FLTSTAT1, type -, offset 0x988, reset 0x0000.0000 (see page 1262)															
								DCMP7	DCMP6	DCMP5	DCMP4	DCMP3	DCMP2	DCMP1	DCMP0
PWMPP, type RO, offset 0xFC0, reset 0x0000.0334 (see page 1265)															
				ONE	EFAULT	ESYNC	FCNT				GCNT				

31	30	29	28	27	26	25	24	23	22	21	20	19	18	17	16		
15	14	13	12	11	10	9	8	7	6	5	4	3	2	1	0		
PWMPC, type R/W, offset 0xFC4, reset 0x0000.0000 (see page 1267)																	
								USEPWMDIV	PWMDIV								
Quadrature Encoder Interface (QEI)																	
QEI0 base: 0x4002.C000																	
QEI1 base: 0x4002.D000																	
QEICTL, type R/W, offset 0x000, reset 0x0000.0000 (see page 1274)																	
												FILCNT					
FILTEN		STALLEN		INVI		INVB		INVA		VELDIV		VELEN	RESMODE	CAPMODE	SIGMODE	SWAP	ENABLE
QEISTAT, type RO, offset 0x004, reset 0x0000.0000 (see page 1277)																	
														DIRECTION		ERROR	
QEIPOS, type R/W, offset 0x008, reset 0x0000.0000 (see page 1278)																	
POSITION																	
POSITION																	
QEIMAXPOS, type R/W, offset 0x00C, reset 0x0000.0000 (see page 1279)																	
MAXPOS																	
MAXPOS																	
QEILOAD, type R/W, offset 0x010, reset 0x0000.0000 (see page 1280)																	
LOAD																	
LOAD																	
QEITIME, type RO, offset 0x014, reset 0x0000.0000 (see page 1281)																	
TIME																	
TIME																	
QEICOUNT, type RO, offset 0x018, reset 0x0000.0000 (see page 1282)																	
COUNT																	
COUNT																	
QEISPEED, type RO, offset 0x01C, reset 0x0000.0000 (see page 1283)																	
SPEED																	
SPEED																	
QEIINTEN, type R/W, offset 0x020, reset 0x0000.0000 (see page 1284)																	
												INTERROR	INTDIR	INTTIMER	INTINDEX		
QEIRIS, type RO, offset 0x024, reset 0x0000.0000 (see page 1286)																	
												INTERROR	INTDIR	INTTIMER	INTINDEX		
QEIISC, type R/W1C, offset 0x028, reset 0x0000.0000 (see page 1288)																	
												INTERROR	INTDIR	INTTIMER	INTINDEX		

B Ordering and Contact Information

B.1 Ordering Information

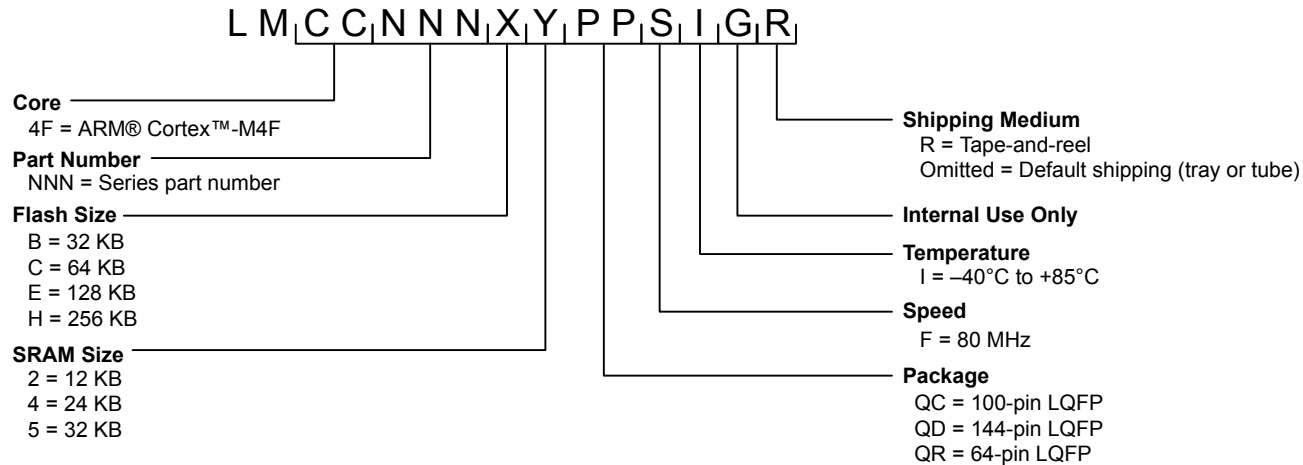

Table B-1. Part Ordering Information

Orderable Part Number	Description
LM4F231H5QRFIG	Stellaris® LM4F231H5QR Microcontroller Industrial Temperature 64-pin LQFP
LM4F231H5QRFIGR	Stellaris LM4F231H5QR Microcontroller Industrial Temperature 64-pin LQFP Tape-and-reel

B.2 Part Markings

The Stellaris microcontrollers are marked with an identifying number. This code contains the following information:

- The first and second lines indicate the part number, for example, LM4F232H5QDFIGA0. The second letter in the part number indicates the product status. An M indicates the part is fully qualified and released to production. An X, for example, LX4F232H5QDFIGA0, indicates the part is experimental and requires a waiver
- The third line contains internal tracking numbers.

B.3 Kits

The Stellaris Family provides the hardware and software tools that engineers need to begin development quickly.

- Reference Design Kits accelerate product development by providing ready-to-run hardware and comprehensive documentation including hardware design files
- Evaluation Kits provide a low-cost and effective means of evaluating Stellaris microcontrollers before purchase
- Development Kits provide you with all the tools you need to develop and prototype embedded applications right out of the box

See the website at www.ti.com/stellaris for the latest tools available, or ask your distributor.

B.4 Support Information

For support on Stellaris products, contact the TI Worldwide Product Information Center nearest you:
<http://www-k.ext.ti.com/sc/technical-support/product-information-centers.htm>.

C Package Information

C.1 64-Pin LQFP Package

C.1.1 Package Dimensions

Figure C-1. Stellaris LM4F231H5QR 64-Pin LQFP Package

MTQF008A – JANUARY 1995 – REVISED DECEMBER 1996

PM (S-PQFP-G64)

PLASTIC QUAD FLATPACK

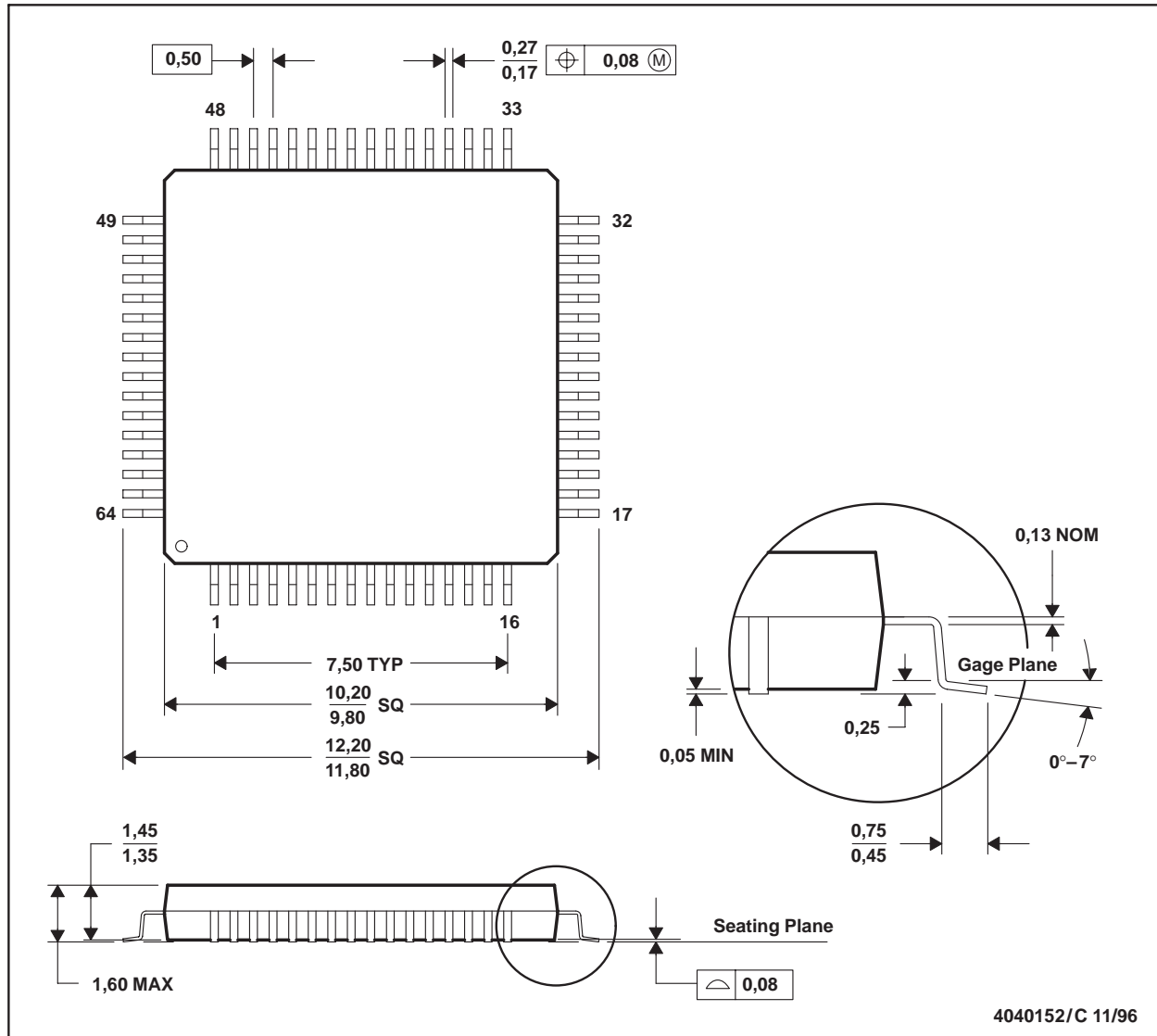

- NOTES:
- A. All linear dimensions are in millimeters.
 - B. This drawing is subject to change without notice.
 - C. Falls within JEDEC MS-026
 - D. May also be thermally enhanced plastic with leads connected to the die pads.

PACKAGING INFORMATION

Orderable Device	Status ⁽¹⁾	Package Type	Package Drawing	Pins	Package Qty	Eco Plan ⁽²⁾	Lead/ Ball Finish	MSL Peak Temp ⁽³⁾	Samples (Requires Login)
LM4F231H5QRFIG	ACTIVE	LQFP	PM	64	160	TBD	Call TI	Call TI	
LM4F231H5QRFIGR	PREVIEW	LQFP	PM	64	1500	TBD	Call TI	Call TI	
LX4F231H5QRFIGA3	ACTIVE	LQFP	PM	64	1	Green (RoHS & no Sb/Br)	CU NIPDAU	Level-3-260C-168 HR	

⁽¹⁾ The marketing status values are defined as follows:

ACTIVE: Product device recommended for new designs.

LIFEBUY: TI has announced that the device will be discontinued, and a lifetime-buy period is in effect.

NRND: Not recommended for new designs. Device is in production to support existing customers, but TI does not recommend using this part in a new design.

PREVIEW: Device has been announced but is not in production. Samples may or may not be available.

OBSELETE: TI has discontinued the production of the device.

⁽²⁾ Eco Plan - The planned eco-friendly classification: Pb-Free (RoHS), Pb-Free (RoHS Exempt), or Green (RoHS & no Sb/Br) - please check <http://www.ti.com/productcontent> for the latest availability information and additional product content details.

TBD: The Pb-Free/Green conversion plan has not been defined.

Pb-Free (RoHS): TI's terms "Lead-Free" or "Pb-Free" mean semiconductor products that are compatible with the current RoHS requirements for all 6 substances, including the requirement that lead not exceed 0.1% by weight in homogeneous materials. Where designed to be soldered at high temperatures, TI Pb-Free products are suitable for use in specified lead-free processes.

Pb-Free (RoHS Exempt): This component has a RoHS exemption for either 1) lead-based flip-chip solder bumps used between the die and package, or 2) lead-based die adhesive used between the die and leadframe. The component is otherwise considered Pb-Free (RoHS compatible) as defined above.

Green (RoHS & no Sb/Br): TI defines "Green" to mean Pb-Free (RoHS compatible), and free of Bromine (Br) and Antimony (Sb) based flame retardants (Br or Sb do not exceed 0.1% by weight in homogeneous material)

⁽³⁾ MSL, Peak Temp. -- The Moisture Sensitivity Level rating according to the JEDEC industry standard classifications, and peak solder temperature.

Important Information and Disclaimer: The information provided on this page represents TI's knowledge and belief as of the date that it is provided. TI bases its knowledge and belief on information provided by third parties, and makes no representation or warranty as to the accuracy of such information. Efforts are underway to better integrate information from third parties. TI has taken and continues to take reasonable steps to provide representative and accurate information but may not have conducted destructive testing or chemical analysis on incoming materials and chemicals. TI and TI suppliers consider certain information to be proprietary, and thus CAS numbers and other limited information may not be available for release.

In no event shall TI's liability arising out of such information exceed the total purchase price of the TI part(s) at issue in this document sold by TI to Customer on an annual basis.

IMPORTANT NOTICE

Texas Instruments Incorporated and its subsidiaries (TI) reserve the right to make corrections, enhancements, improvements and other changes to its semiconductor products and services per JESD46C and to discontinue any product or service per JESD48B. Buyers should obtain the latest relevant information before placing orders and should verify that such information is current and complete. All semiconductor products (also referred to herein as "components") are sold subject to TI's terms and conditions of sale supplied at the time of order acknowledgment.

TI warrants performance of its components to the specifications applicable at the time of sale, in accordance with the warranty in TI's terms and conditions of sale of semiconductor products. Testing and other quality control techniques are used to the extent TI deems necessary to support this warranty. Except where mandated by applicable law, testing of all parameters of each component is not necessarily performed.

TI assumes no liability for applications assistance or the design of Buyers' products. Buyers are responsible for their products and applications using TI components. To minimize the risks associated with Buyers' products and applications, Buyers should provide adequate design and operating safeguards.

TI does not warrant or represent that any license, either express or implied, is granted under any patent right, copyright, mask work right, or other intellectual property right relating to any combination, machine, or process in which TI components or services are used. Information published by TI regarding third-party products or services does not constitute a license to use such products or services or a warranty or endorsement thereof. Use of such information may require a license from a third party under the patents or other intellectual property of the third party, or a license from TI under the patents or other intellectual property of TI.

Reproduction of significant portions of TI information in TI data books or data sheets is permissible only if reproduction is without alteration and is accompanied by all associated warranties, conditions, limitations, and notices. TI is not responsible or liable for such altered documentation. Information of third parties may be subject to additional restrictions.

Resale of TI components or services with statements different from or beyond the parameters stated by TI for that component or service voids all express and any implied warranties for the associated TI component or service and is an unfair and deceptive business practice. TI is not responsible or liable for any such statements.

Buyer acknowledges and agrees that it is solely responsible for compliance with all legal, regulatory and safety-related requirements concerning its products, and any use of TI components in its applications, notwithstanding any applications-related information or support that may be provided by TI. Buyer represents and agrees that it has all the necessary expertise to create and implement safeguards which anticipate dangerous consequences of failures, monitor failures and their consequences, lessen the likelihood of failures that might cause harm and take appropriate remedial actions. Buyer will fully indemnify TI and its representatives against any damages arising out of the use of any TI components in safety-critical applications.

In some cases, TI components may be promoted specifically to facilitate safety-related applications. With such components, TI's goal is to help enable customers to design and create their own end-product solutions that meet applicable functional safety standards and requirements. Nonetheless, such components are subject to these terms.

No TI components are authorized for use in FDA Class III (or similar life-critical medical equipment) unless authorized officers of the parties have executed a special agreement specifically governing such use.

Only those TI components which TI has specifically designated as military grade or "enhanced plastic" are designed and intended for use in military/aerospace applications or environments. Buyer acknowledges and agrees that any military or aerospace use of TI components which have **not** been so designated is solely at the Buyer's risk, and that Buyer is solely responsible for compliance with all legal and regulatory requirements in connection with such use.

TI has specifically designated certain components which meet ISO/TS16949 requirements, mainly for automotive use. Components which have not been so designated are neither designed nor intended for automotive use; and TI will not be responsible for any failure of such components to meet such requirements.

Products

Audio	www.ti.com/audio
Amplifiers	amplifier.ti.com
Data Converters	dataconverter.ti.com
DLP® Products	www.dlp.com
DSP	dsp.ti.com
Clocks and Timers	www.ti.com/clocks
Interface	interface.ti.com
Logic	logic.ti.com
Power Mgmt	power.ti.com
Microcontrollers	microcontroller.ti.com
RFID	www.ti-rfid.com
OMAP Mobile Processors	www.ti.com/omap
Wireless Connectivity	www.ti.com/wirelessconnectivity

Applications

Automotive and Transportation	www.ti.com/automotive
Communications and Telecom	www.ti.com/communications
Computers and Peripherals	www.ti.com/computers
Consumer Electronics	www.ti.com/consumer-apps
Energy and Lighting	www.ti.com/energy
Industrial	www.ti.com/industrial
Medical	www.ti.com/medical
Security	www.ti.com/security
Space, Avionics and Defense	www.ti.com/space-avionics-defense
Video and Imaging	www.ti.com/video

TI E2E Community e2e.ti.com

Looking for pricing, stock, or lifecycle information?

Click below to explore more details on WIN SOURCE:

 [View LX4F231H5QRFIGA3 on WIN SOURCE](#)

 [Texas Instruments](#) Information

Optimize Your Supply Chain with WIN SOURCE Solutions

-  Global Sourcing Solution
-  Obsolete Management
-  Cost Control Management
-  Shortage Management
-  Alternative Solution
-  Excess Inventory Management