



**THE DATASHEET OF  
M28W160ECT70ZB6E**



### FEATURES SUMMARY

- SUPPLY VOLTAGE
  - $V_{DD} = 2.7V$  to  $3.6V$  Core Power Supply
  - $V_{DDQ} = 1.65V$  to  $3.6V$  for Input/Output
  - $V_{PP} = 12V$  for fast Program (optional)
- ACCESS TIME: 70, 85, 90, 100ns
- PROGRAMMING TIME:
  - $10\mu s$  typical
  - Double Word Programming Option
- COMMON FLASH INTERFACE
  - 64 bit Security Code
- MEMORY BLOCKS
  - Parameter Blocks (Top or Bottom location)
  - Main Blocks
- BLOCK LOCKING
  - All blocks locked at Power Up
  - Any combination of blocks can be locked
  - $\overline{WP}$  for Block Lock-Down
- SECURITY
  - 64 bit user Programmable OTP cells
  - 64 bit unique device identifier
  - One Parameter Block Permanently Lockable
- AUTOMATIC STAND-BY MODE
- PROGRAM and ERASE SUSPEND
- 100,000 PROGRAM/ERASE CYCLES per BLOCK
- ELECTRONIC SIGNATURE
  - Manufacturer Code: 20h
  - Top Device Code, M28W160ECT: 88CEh
  - Bottom Device Code, M28W160ECB: 88CFh
- ECOPACK PACKAGES AVAILABLE

Figure 1. Packages

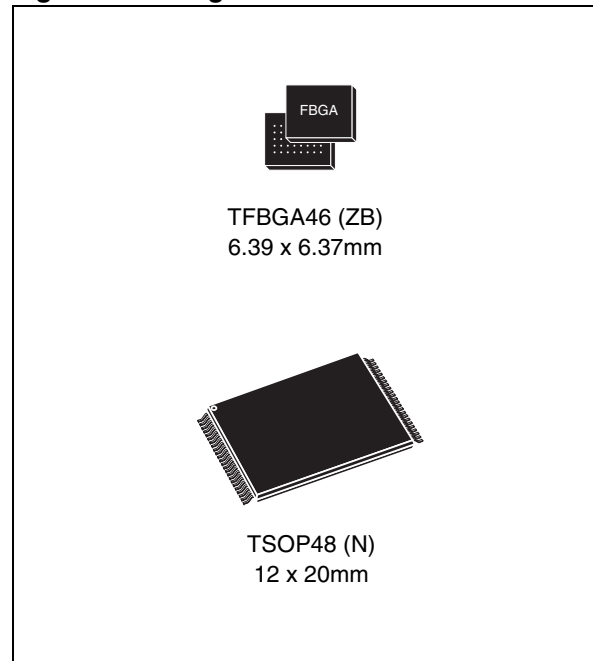

## TABLE OF CONTENTS

<b>FEATURES SUMMARY</b> .....	<b>1</b>
Figure 1. Packages.....	1
<b>SUMMARY DESCRIPTION</b> .....	<b>5</b>
Figure 2. Logic Diagram .....	6
Table 1. Signal Names .....	6
Figure 3. TSOP Connections .....	6
Figure 4. TFBGA Connections (Top view through package) .....	7
Figure 5. Block Addresses .....	7
Figure 6. Security Block and Protection Register Memory Map .....	8
<b>SIGNAL DESCRIPTIONS</b> .....	<b>9</b>
Address Inputs (A0-A19).....	9
Data Input/Output (DQ0-DQ15).....	9
Chip Enable ( $\bar{E}$ ).....	9
Output Enable ( $\bar{G}$ ).....	9
Write Enable ( $\bar{W}$ ).....	9
Write Protect ( $\bar{WP}$ ).....	9
Reset ( $\bar{RP}$ ).....	9
V <sub>DD</sub> Supply Voltage.....	9
V <sub>DDQ</sub> Supply Voltage.....	9
V <sub>PP</sub> Program Supply Voltage .....	9
V <sub>SS</sub> Ground.....	9
<b>BUS OPERATIONS</b> .....	<b>10</b>
Read.....	10
Write.....	10
Output Disable.....	10
Standby.....	10
Automatic Standby.....	10
Reset.....	10
Table 2. Bus Operations .....	10
<b>COMMAND INTERFACE</b> .....	<b>11</b>
Read Memory Array Command .....	11
Read Status Register Command .....	11
Read Electronic Signature Command.....	11
Read CFI Query Command.....	11
Block Erase Command .....	11
Program Command.....	11
Double Word Program Command .....	12
Clear Status Register Command .....	12
Program/Erase Suspend Command .....	12

<b>Program/Erase Resume Command</b> .....	<b>12</b>
<b>Protection Register Program Command</b> .....	<b>12</b>
<b>Block Lock Command</b> .....	<b>13</b>
<b>Block Unlock Command</b> .....	<b>13</b>
<b>Block Lock-Down Command</b> .....	<b>13</b>
Table 3. Commands .....	14
Table 4. Read Electronic Signature .....	14
Table 5. Read Block Lock Signature .....	15
Table 6. Read Protection Register and Lock Register .....	15
Table 7. Program, Erase Times and Program/Erase Endurance Cycles .....	15
<b>BLOCK LOCKING</b> .....	<b>16</b>
<b>Reading a Block's Lock Status</b> .....	<b>16</b>
<b>Locked State</b> .....	<b>16</b>
<b>Unlocked State</b> .....	<b>16</b>
<b>Lock-Down State</b> .....	<b>16</b>
<b>Locking Operations During Erase Suspend</b> .....	<b>16</b>
Table 8. Block Lock Status .....	17
Table 9. Protection Status .....	17
<b>STATUS REGISTER</b> .....	<b>18</b>
Program/Erase Controller Status (Bit 7) .....	18
Erase Suspend Status (Bit 6) .....	18
Erase Status (Bit 5) .....	18
Program Status (Bit 4) .....	18
V <sub>PP</sub> Status (Bit 3) .....	18
Program Suspend Status (Bit 2) .....	18
Block Protection Status (Bit 1) .....	19
Reserved (Bit 0) .....	19
Table 10. Status Register Bits .....	19
<b>MAXIMUM RATING</b> .....	<b>20</b>
Table 11. Absolute Maximum Ratings .....	20
<b>DC and AC PARAMETERS</b> .....	<b>21</b>
Table 12. Operating and AC Measurement Conditions .....	21
Figure 7. AC Measurement I/O Waveform .....	21
Figure 8. AC Measurement Load Circuit .....	21
Table 13. Capacitance .....	21
Table 14. DC Characteristics .....	22
Figure 9. Read Mode AC Waveforms .....	23
Table 15. Read AC Characteristics .....	23
Figure 10. Write AC Waveforms, Write Enable Controlled .....	24
Table 16. Write AC Characteristics, Write Enable Controlled .....	25
Figure 11. Write AC Waveforms, Chip Enable Controlled .....	26
Table 17. Write AC Characteristics, Chip Enable Controlled .....	27

## M28W160ECT, M28W160ECB

---

Figure 12. Power-Up and Reset AC Waveforms . . . . .	28
Table 18. Power-Up and Reset AC Characteristics . . . . .	28
<b>PACKAGE MECHANICAL . . . . .</b>	<b>29</b>
Figure 13. TSOP48 - 48 lead Plastic Thin Small Outline, 12 x 20mm, Package Outline . . . . .	29
Table 19. TSOP48 - 48 lead Plastic Thin Small Outline, 12 x 20mm, Package Mechanical Data . . . . .	29
Figure 14. TFBGA46 6.39x6.37mm - 8x6 ball array, 0.75mm pitch, Bottom View Package Outline . . . . .	30
Table 20. TFBGA46 6.39x6.37mm - 8x6 ball array, 0.75mm pitch, Package Mechanical Data . . . . .	30
Figure 15. TFBGA46 Daisy Chain - Package Connections (Top view through package) . . . . .	31
Figure 16. TFBGA46 Daisy Chain - PCB Connections proposal (Top view through package) . . . . .	31
<b>PART NUMBERING . . . . .</b>	<b>32</b>
Table 21. Ordering Information Scheme . . . . .	32
Table 22. Daisy Chain Ordering Scheme . . . . .	33
<b>APPENDIX A. BLOCK ADDRESS TABLES . . . . .</b>	<b>34</b>
Table 23. Top Boot Block Addresses, M28W160ECT . . . . .	34
Table 24. Bottom Boot Block Addresses, M28W160ECB . . . . .	34
<b>APPENDIX B. COMMON FLASH INTERFACE (CFI) . . . . .</b>	<b>35</b>
Table 25. Query Structure Overview . . . . .	35
Table 26. CFI Query Identification String . . . . .	35
Table 27. CFI Query System Interface Information . . . . .	36
Table 28. Device Geometry Definition . . . . .	37
Table 29. Primary Algorithm-Specific Extended Query Table . . . . .	38
Table 30. Security Code Area . . . . .	39
<b>APPENDIX C. FLOWCHARTS AND PSEUDO CODES . . . . .</b>	<b>40</b>
Figure 17. Program Flowchart and Pseudo Code . . . . .	40
Figure 18. Double Word Program Flowchart and Pseudo Code . . . . .	41
Figure 19. Program Suspend & Resume Flowchart and Pseudo Code . . . . .	42
Figure 20. Erase Flowchart and Pseudo Code . . . . .	43
Figure 21. Erase Suspend & Resume Flowchart and Pseudo Code . . . . .	44
Figure 22. Locking Operations Flowchart and Pseudo Code . . . . .	45
Figure 23. Protection Register Program Flowchart and Pseudo Code . . . . .	46
<b>APPENDIX D. COMMAND INTERFACE AND PROGRAM/ERASE CONTROLLER STATE . . . . .</b>	<b>47</b>
Table 31. Write State Machine Current/Next, sheet 1 of 2 . . . . .	47
Table 32. Write State Machine Current/Next, sheet 2 of 2 . . . . .	48
<b>REVISION HISTORY . . . . .</b>	<b>49</b>
Table 33. Document Revision History . . . . .	49

## SUMMARY DESCRIPTION

The M28W160EC is a 16 Mbit (1 Mbit x 16) non-volatile Flash memory that can be erased electrically at the block level and programmed in-system on a Word-by-Word basis. These operations can be performed using a single low voltage (2.7 to 3.6V) supply.  $V_{DDQ}$  allows to drive the I/O pin down to 1.65V. An optional 12V  $V_{PP}$  power supply is provided to speed up customer programming.

The device features an asymmetrical blocked architecture. The M28W160EC has an array of 39 blocks: 8 Parameter Blocks of 4 KWord and 31 Main Blocks of 32 KWord. M28W160ECT has the Parameter Blocks at the top of the memory address space while the M28W160ECB locates the Parameter Blocks starting from the bottom. The memory maps are shown in [Figure 5., Block Addresses](#).

The M28W160EC features an instant, individual block locking scheme that allows any block to be locked or unlocked with no latency, enabling instant code and data protection. All blocks have three levels of protection. They can be locked and locked-down individually preventing any accidental programming or erasure. There is an additional hardware protection against program and erase. When  $V_{PP} \leq V_{PPLK}$  all blocks are protected against program or erase. All blocks are locked at power-up.

Each block can be erased separately. Erase can be suspended in order to perform either read or program in any other block and then resumed. Program can be suspended to read data in any other block and then resumed. Each block can be programmed and erased over 100,000 cycles.

The device includes a 128 bit Protection Register and a Security Block to increase the protection of a system design. The Protection Register is divided into two 64 bit segments, the first one contains a unique device number written by Numonyx, while the second one is one-time-programmable by the user. The user programmable segment can be permanently protected. The Security Block, parameter block 0, can be permanently protected by the user. [Figure 6.](#), shows the Security Block and Protection Register Memory Map.

Program and Erase commands are written to the Command Interface of the memory. An on-chip Program/Erase Controller takes care of the timings necessary for program and erase operations. The end of a program or erase operation can be detected and any error conditions identified. The command set required to control the memory is consistent with JEDEC standards.

The memory is offered in TSOP48 (10 X 20mm) and TFBGA46 (6.39 x 6.37mm, 0.75mm pitch) packages.

In order to meet environmental requirements, Numonyx also offers the M28W160ECT and the M28W160ECB in ECOPACK<sup>®</sup> packages. ECOPACK packages are Lead-free. The category of second Level Interconnect is marked on the package and on the inner box label, in compliance with JEDEC Standard JESD97. The maximum ratings related to soldering conditions are also marked on the inner box label.

The memories are supplied with all the bits erased (set to '1').

## M28W160ECT, M28W160ECB

Figure 2. Logic Diagram

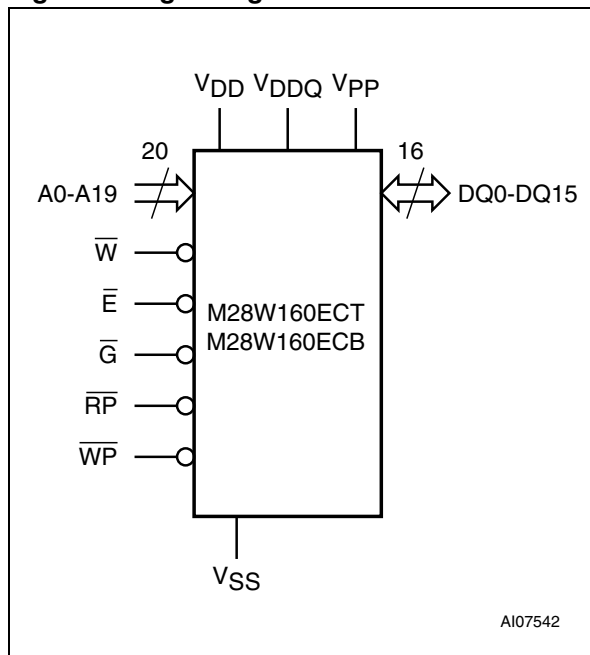

Table 1. Signal Names

A0-A19	Address Inputs
DQ0-DQ15	Data Input/Output
$\bar{E}$	Chip Enable
$\bar{G}$	Output Enable
$\bar{W}$	Write Enable
$\overline{RP}$	Reset
$\overline{WP}$	Write Protect
VDD	Core Power Supply
VDDQ	Power Supply for Input/Output
VPP	Optional Supply Voltage for Fast Program & Erase
VSS	Ground
NC	Not Connected Internally

Figure 3. TSOP Connections

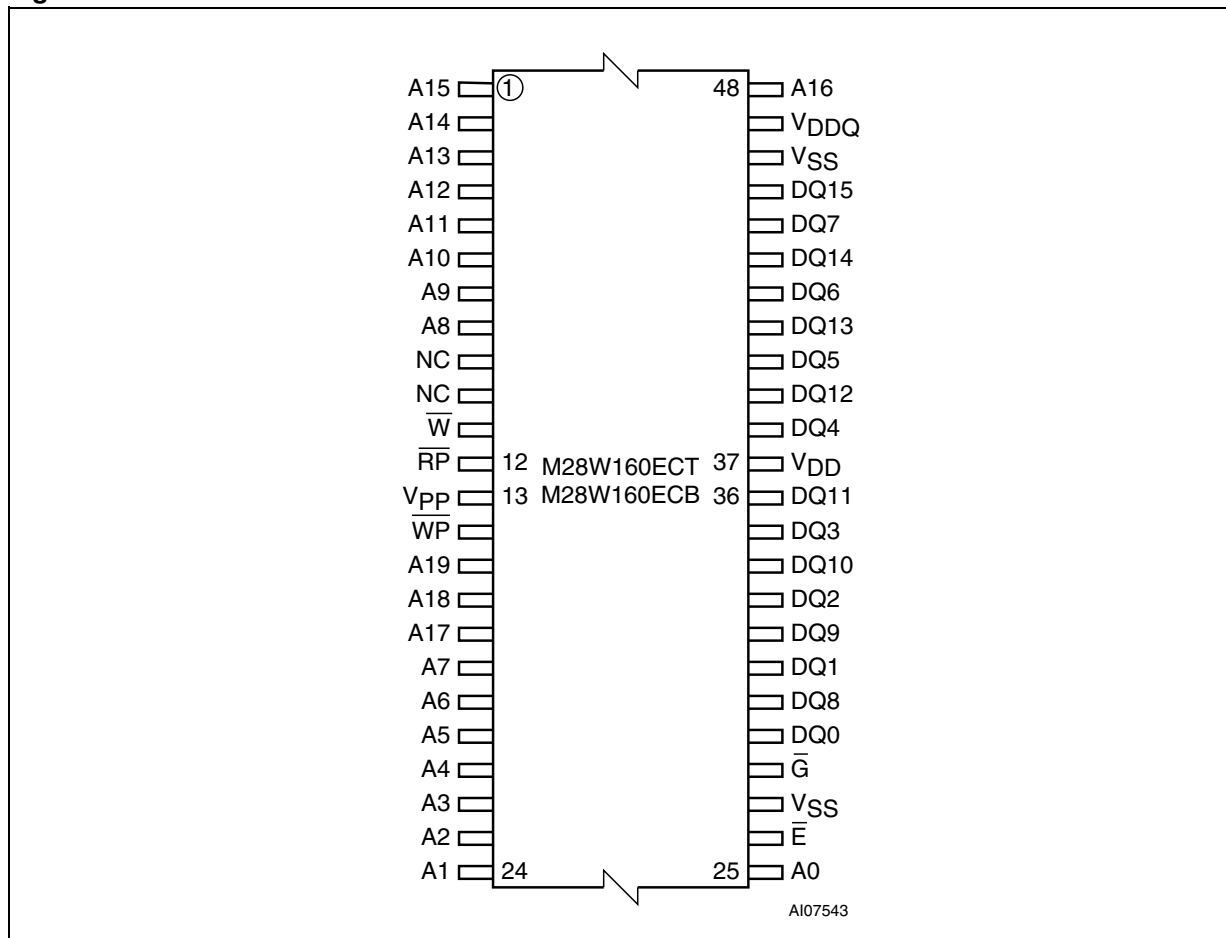

Figure 4. TFBGA Connections (Top view through package)

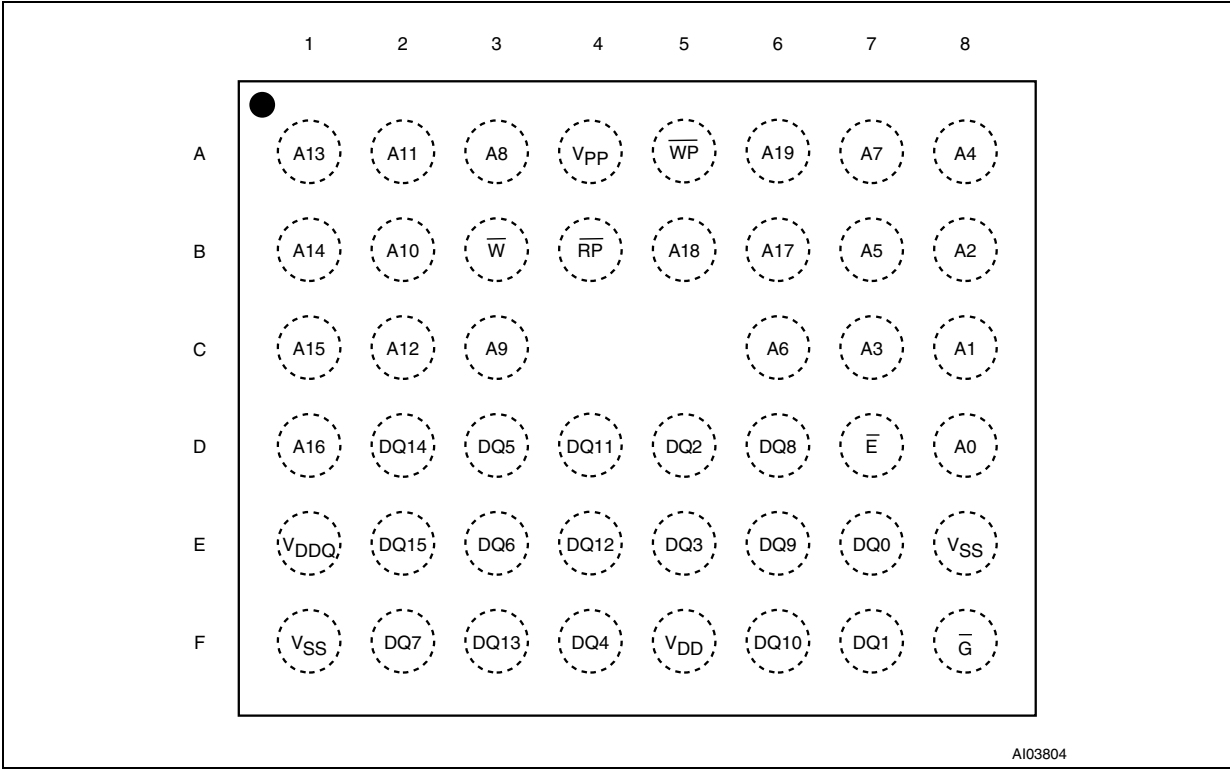
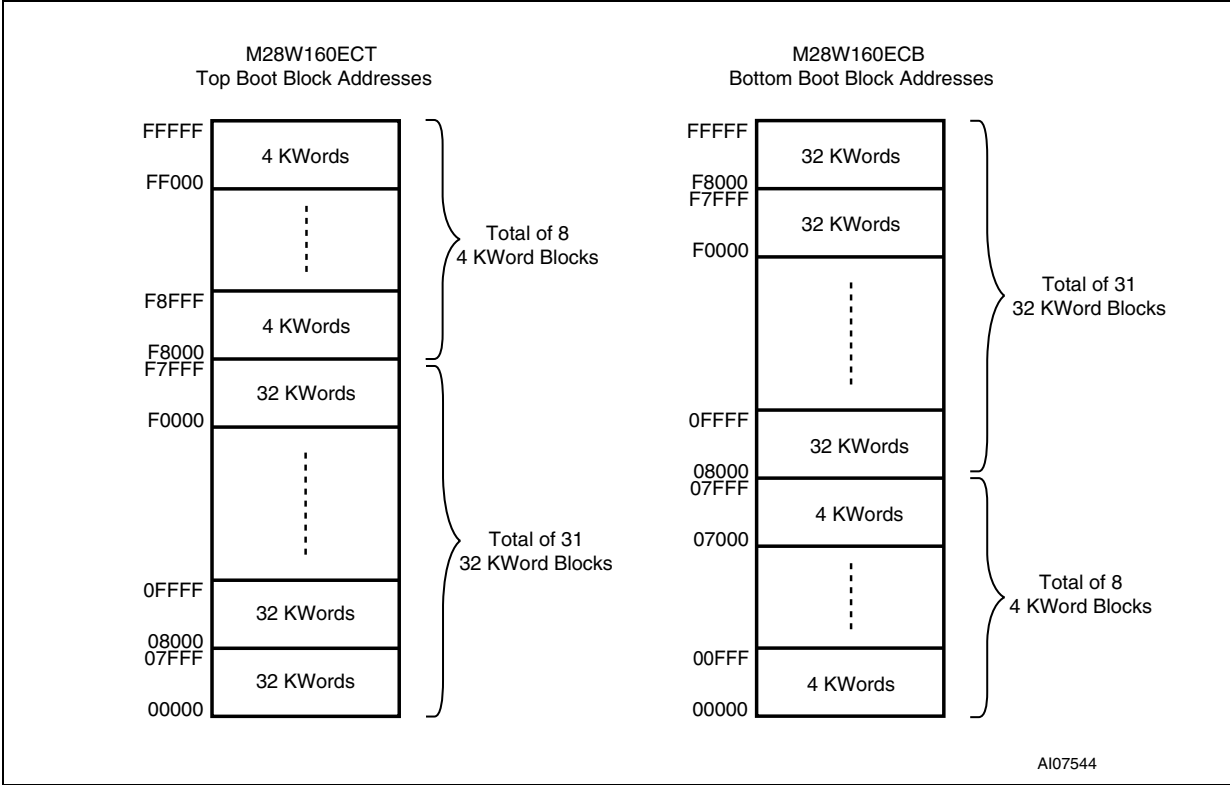
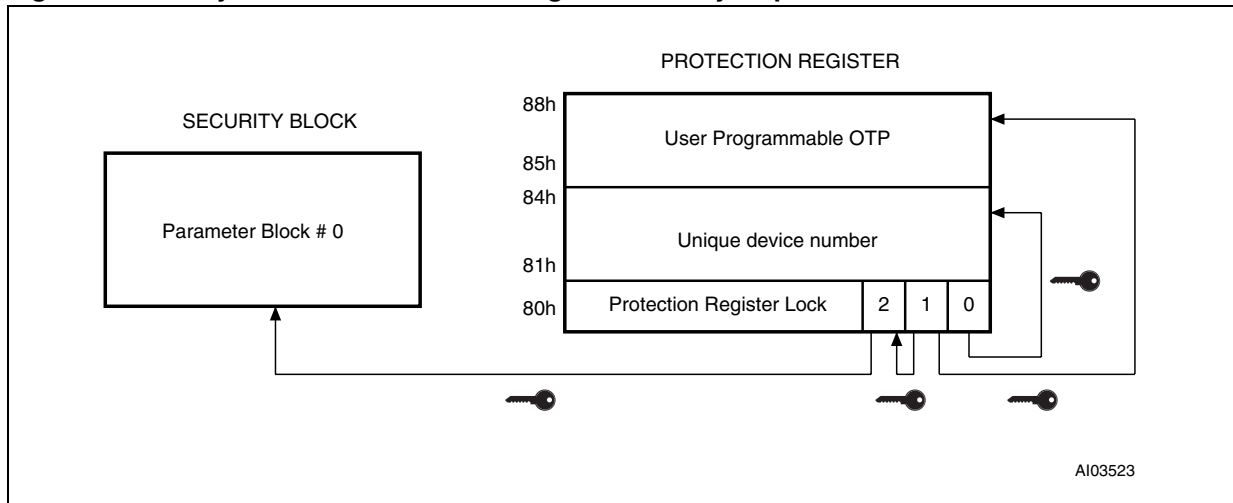

Figure 5. Block Addresses



Note: Also see APPENDIX A., Table 23. and Table 24. for a full listing of the Block Addresses.

Figure 6. Security Block and Protection Register Memory Map



## SIGNAL DESCRIPTIONS

See [Figure 2., Logic Diagram](#) and [Table 1., Signal Names](#), for a brief overview of the signals connected to this device.

**Address Inputs (A0-A19).** The Address Inputs select the cells in the memory array to access during Bus Read operations. During Bus Write operations they control the commands sent to the Command Interface of the internal state machine.

**Data Input/Output (DQ0-DQ15).** The Data I/O outputs the data stored at the selected address during a Bus Read operation or inputs a command or the data to be programmed during a Write Bus operation.

**Chip Enable ( $\bar{E}$ ).** The Chip Enable input activates the memory control logic, input buffers, decoders and sense amplifiers. When Chip Enable is at  $V_{IL}$  and Reset is at  $V_{IH}$  the device is in active mode. When Chip Enable is at  $V_{IH}$  the memory is deselected, the outputs are high impedance and the power consumption is reduced to the stand-by level.

**Output Enable ( $\bar{G}$ ).** The Output Enable controls data outputs during the Bus Read operation of the memory.

**Write Enable ( $\bar{W}$ ).** The Write Enable controls the Bus Write operation of the memory's Command Interface. The data and address inputs are latched on the rising edge of Chip Enable,  $\bar{E}$ , or Write Enable,  $\bar{W}$ , whichever occurs first.

**Write Protect ( $\bar{WP}$ ).** Write Protect is an input that gives an additional hardware protection for each block. When Write Protect is at  $V_{IL}$ , the Lock-Down is enabled and the protection status of the block cannot be changed. When Write Protect is at  $V_{IH}$ , the Lock-Down is disabled and the block can be locked or unlocked. (refer to [Table 6., Read Protection Register and Lock Register](#)).

**Reset ( $\bar{RP}$ ).** The Reset input provides a hardware reset of the memory. When Reset is at  $V_{IL}$ , the memory is in reset mode: the outputs are high impedance and the current consumption is minimized. After Reset all blocks are in the Locked

state. When Reset is at  $V_{IH}$ , the device is in normal operation. Exiting reset mode the device enters read array mode, but a negative transition of Chip Enable or a change of the address is required to ensure valid data outputs.

**$V_{DD}$  Supply Voltage.**  $V_{DD}$  provides the power supply to the internal core of the memory device. It is the main power supply for all operations (Read, Program and Erase).

**$V_{DDQ}$  Supply Voltage.**  $V_{DDQ}$  provides the power supply to the I/O pins and enables all Outputs to be powered independently from  $V_{DD}$ .  $V_{DDQ}$  can be tied to  $V_{DD}$  or can use a separate supply.

**$V_{PP}$  Program Supply Voltage.**  $V_{PP}$  is both a control input and a power supply pin. The two functions are selected by the voltage range applied to the pin. The Supply Voltage  $V_{DD}$  and the Program Supply Voltage  $V_{PP}$  can be applied in any order.

If  $V_{PP}$  is kept in a low voltage range (0V to 3.6V)  $V_{PP}$  is seen as a control input. In this case a voltage lower than  $V_{PPLK}$  gives an absolute protection against program or erase, while  $V_{PP} > V_{PP1}$  enables these functions (see [Table 14., DC Characteristics](#), for the relevant values).  $V_{PP}$  is only sampled at the beginning of a program or erase; a change in its value after the operation has started does not have any effect and program or erase operations continue.

If  $V_{PP}$  is in the range 11.4V to 12.6V it acts as a power supply pin. In this condition  $V_{PP}$  must be stable until the Program/Erase algorithm is completed (see [Table 16.](#) and [Table 17.](#)).

**$V_{SS}$  Ground.**  $V_{SS}$  is the reference for all voltage measurements.

**Note:** Each device in a system should have  $V_{DD}$ ,  $V_{DDQ}$  and  $V_{PP}$  decoupled with a 0.1 $\mu$ F capacitor close to the pin. See [Figure 8., AC Measurement Load Circuit](#). The PCB trace widths should be sufficient to carry the required  $V_{PP}$  program and erase currents.

## BUS OPERATIONS

There are six standard bus operations that control the device. These are Bus Read, Bus Write, Output Disable, Standby, Automatic Standby and Reset. See [Table 2., Bus Operations](#), for a summary.

Typically glitches of less than 5ns on Chip Enable or Write Enable are ignored by the memory and do not affect bus operations.

**Read.** Read Bus operations are used to output the contents of the Memory Array, the Electronic Signature, the Status Register and the Common Flash Interface. Both Chip Enable and Output Enable must be at  $V_{IL}$  in order to perform a read operation. The Chip Enable input should be used to enable the device. Output Enable should be used to gate data onto the output. The data read depends on the previous command written to the memory (see Command Interface section). See [Figure 9., Read Mode AC Waveforms](#), and [Table 15., Read AC Characteristics](#), for details of when the output becomes valid.

Read mode is the default state of the device when exiting Reset or after power-up.

**Write.** Bus Write operations write Commands to the memory or latch Input Data to be programmed. A write operation is initiated when Chip Enable and Write Enable are at  $V_{IL}$  with Output Enable at  $V_{IH}$ . Commands, Input Data and Addresses are latched on the rising edge of Write Enable or Chip Enable, whichever occurs first.

See [Figures 10 and 11, Write AC Waveforms](#), and [Tables 16 and 17, Write AC Characteristics](#), for details of the timing requirements.

**Output Disable.** The data outputs are high impedance when the Output Enable is at  $V_{IH}$ .

**Standby.** Standby disables most of the internal circuitry allowing a substantial reduction of the current consumption. The memory is in stand-by when Chip Enable is at  $V_{IH}$  and the device is in read mode. The power consumption is reduced to the stand-by level and the outputs are set to high impedance, independently from the Output Enable or Write Enable inputs. If Chip Enable switches to  $V_{IH}$  during a program or erase operation, the device enters Standby mode when finished.

**Automatic Standby.** Automatic Standby provides a low power consumption state during Read mode. Following a read operation, the device enters Automatic Standby after 150ns of bus inactivity even if Chip Enable is Low,  $V_{IL}$ , and the supply current is reduced to  $I_{DD1}$ . The data Inputs/Outputs will still output data if a bus Read operation is in progress.

**Reset.** During Reset mode when Output Enable is Low,  $V_{IL}$ , the memory is deselected and the outputs are high impedance. The memory is in Reset mode when Reset is at  $V_{IL}$ . The power consumption is reduced to the Standby level, independently from the Chip Enable, Output Enable or Write Enable inputs. If Reset is pulled to  $V_{SS}$  during a Program or Erase, this operation is aborted and the memory content is no longer valid.

**Table 2. Bus Operations**

Operation	$\bar{E}$	$\bar{G}$	$\bar{W}$	$\bar{RP}$	$\bar{WP}$	$V_{PP}$	DQ0-DQ15
Bus Read	$V_{IL}$	$V_{IL}$	$V_{IH}$	$V_{IH}$	X	Don't Care	Data Output
Bus Write	$V_{IL}$	$V_{IH}$	$V_{IL}$	$V_{IH}$	X	$V_{DD}$ or $V_{PPH}$	Data Input
Output Disable	$V_{IL}$	$V_{IH}$	$V_{IH}$	$V_{IH}$	X	Don't Care	Hi-Z
Standby	$V_{IH}$	X	X	$V_{IH}$	X	Don't Care	Hi-Z
Reset	X	X	X	$V_{IL}$	X	Don't Care	Hi-Z

Note: X =  $V_{IL}$  or  $V_{IH}$ ,  $V_{PPH} = 12V \pm 5\%$ .

## COMMAND INTERFACE

All Bus Write operations to the memory are interpreted by the Command Interface. Commands consist of one or more sequential Bus Write operations. An internal Program/Erase Controller handles all timings and verifies the correct execution of the Program and Erase commands. The Program/Erase Controller provides a Status Register whose output may be read at any time during, to monitor the progress of the operation, or the Program/Erase states. See [APPENDIX D., Table 31.](#), Write State Machine Current/Next, for a summary of the Command Interface.

The Command Interface is reset to Read mode when power is first applied, when exiting from Reset or whenever  $V_{DD}$  is lower than  $V_{LKO}$ . Command sequences must be followed exactly. Any invalid combination of commands will reset the device to Read mode. Refer to [Table 3., Commands](#), in conjunction with the text descriptions below.

### Read Memory Array Command

The Read command returns the memory to its Read mode. One Bus Write cycle is required to issue the Read Memory Array command and return the memory to Read mode. Subsequent read operations will read the addressed location and output the data. When a device Reset occurs, the memory defaults to Read mode.

### Read Status Register Command

The Status Register indicates when a program or erase operation is complete and the success or failure of the operation itself. Issue a Read Status Register command to read the Status Register's contents. Subsequent Bus Read operations read the Status Register at any address, until another command is issued. See [Table 10., Status Register Bits](#), for details on the definitions of the bits.

The Read Status Register command may be issued at any time, even during a Program/Erase operation. Any Read attempt during a Program/Erase operation will automatically output the content of the Status Register.

### Read Electronic Signature Command

The Read Electronic Signature command reads the Manufacturer and Device Codes and the Block Locking Status, or the Protection Register.

The Read Electronic Signature command consists of one write cycle, a subsequent read will output the Manufacturer Code, the Device Code, the Block Lock and Lock-Down Status, or the Protection and Lock Register. See [Tables 4, 5 and 6](#) for the valid address.

### Read CFI Query Command

The Read Query Command is used to read data from the Common Flash Interface (CFI) Memory Area, allowing programming equipment or appli-

cations to automatically match their interface to the characteristics of the device. One Bus Write cycle is required to issue the Read Query Command. Once the command is issued subsequent Bus Read operations read from the Common Flash Interface Memory Area. See [APPENDIX B., COMMON FLASH INTERFACE \(CFI\)](#), [Tables 25, 26, 27, 28, 29 and 30](#) for details on the information contained in the Common Flash Interface memory area.

### Block Erase Command

The Block Erase command can be used to erase a block. It sets all the bits within the selected block to '1'. All previous data in the block is lost. If the block is protected then the Erase operation will abort, the data in the block will not be changed and the Status Register will output the error.

Two Bus Write cycles are required to issue the command.

- The first bus cycle sets up the Erase command.
- The second latches the block address in the internal state machine and starts the Program/Erase Controller.

If the second bus cycle is not Write Erase Confirm (D0h), Status Register bits b4 and b5 are set and the command aborts.

Erase aborts if Reset turns to  $V_{IL}$ . As data integrity cannot be guaranteed when the Erase operation is aborted, the block must be erased again.

During Erase operations the memory will accept the Read Status Register command and the Program/Erase Suspend command, all other commands will be ignored. Typical Erase times are given in [Table 7., Program, Erase Times and Program/Erase Endurance Cycles](#).

See [APPENDIX C., Figure 20., Erase Flowchart and Pseudo Code](#), for a suggested flowchart for using the Erase command.

### Program Command

The memory array can be programmed word-by-word. Two bus write cycles are required to issue the Program Command.

- The first bus cycle sets up the Program command.
- The second latches the Address and the Data to be written and starts the Program/Erase Controller.

During Program operations the memory will accept the Read Status Register command and the Program/Erase Suspend command. Typical Program times are given in [Table 7., Program, Erase Times and Program/Erase Endurance Cycles](#).

Programming aborts if Reset goes to  $V_{IL}$ . As data integrity cannot be guaranteed when the program operation is aborted, the block containing the memory location must be erased and reprogrammed.

See [APPENDIX C., Figure 17., Program Flowchart and Pseudo Code](#), for the flowchart for using the Program command.

### Double Word Program Command

This feature is offered to improve the programming throughput, writing a page of two adjacent words in parallel. The two words must differ only for the address A0. Programming should not be attempted when  $V_{PP}$  is not at  $V_{PPH}$ . The command can be executed if  $V_{PP}$  is below  $V_{PPH}$  but the result is not guaranteed.

Three bus write cycles are necessary to issue the Double Word Program command.

- The first bus cycle sets up the Double Word Program Command.
- The second bus cycle latches the Address and the Data of the first word to be written.
- The third bus cycle latches the Address and the Data of the second word to be written and starts the Program/Erase Controller.

Read operations output the Status Register content after the programming has started. Programming aborts if Reset goes to  $V_{IL}$ . As data integrity cannot be guaranteed when the program operation is aborted, the block containing the memory location must be erased and reprogrammed.

See [APPENDIX C., Figure 18., Double Word Program Flowchart and Pseudo Code](#), for the flowchart for using the Double Word Program command.

### Clear Status Register Command

The Clear Status Register command can be used to reset bits 1, 3, 4 and 5 in the Status Register to '0'. One bus write cycle is required to issue the Clear Status Register command.

The bits in the Status Register do not automatically return to '0' when a new Program or Erase command is issued. The error bits in the Status Register should be cleared before attempting a new Program or Erase command.

### Program/Erase Suspend Command

The Program/Erase Suspend command is used to pause a Program or Erase operation. One bus write cycle is required to issue the Program/Erase command and pause the Program/Erase controller.

During Program/Erase Suspend the Command Interface will accept the Program/Erase Resume, Read Array, Read Status Register, Read Electronic Signature and Read CFI Query commands. Ad-

ditionally, if the suspend operation was Erase then the Program, Block Lock, Block Lock-Down or Protection Program commands will also be accepted. The block being erased may be protected by issuing the Block Protect, Block Lock or Protection Program commands. When the Program/Erase Resume command is issued the operation will complete. Only the blocks not being erased may be read or programmed correctly.

During a Program/Erase Suspend, the device can be placed in a pseudo-standby mode by taking Chip Enable to  $V_{IH}$ . Program/Erase is aborted if Reset turns to  $V_{IL}$ .

See [APPENDIX C., Figure 19., Program Suspend & Resume Flowchart and Pseudo Code](#), and [Figure 21., Erase Suspend & Resume Flowchart and Pseudo Code](#), for flowcharts for using the Program/Erase Suspend command.

### Program/Erase Resume Command

The Program/Erase Resume command can be used to restart the Program/Erase Controller after a Program/Erase Suspend operation has paused it. One Bus Write cycle is required to issue the command. Once the command is issued subsequent Bus Read operations read the Status Register.

See [APPENDIX C., Figure 19., Program Suspend & Resume Flowchart and Pseudo Code](#), and [Figure 21., Erase Suspend & Resume Flowchart and Pseudo Code](#), for flowcharts for using the Program/Erase Resume command.

### Protection Register Program Command

The Protection Register Program command is used to Program the 64 bit user One-Time-Programmable (OTP) segment of the Protection Register. The segment is programmed 16 bits at a time. When shipped all bits in the segment are set to '1'. The user can only program the bits to '0'.

Two write cycles are required to issue the Protection Register Program command.

- The first bus cycle sets up the Protection Register Program command.
- The second latches the Address and the Data to be written to the Protection Register and starts the Program/Erase Controller.

Read operations output the Status Register content after the programming has started.

The segment can be protected by programming bit 1 of the Protection Lock Register. Bit 1 of the Protection Lock Register protects bit 2 of the Protection Lock Register. Programming bit 2 of the Protection Lock Register will result in a permanent protection of the Security Block (see [Figure 6., Security Block and Protection Register Memory Map](#)). Attempting to program a previously protected Protection Register will result in a Status

Register error. The protection of the Protection Register and/or the Security Block is not reversible.

The Protection Register Program cannot be suspended. See [APPENDIX C., Figure 23., Protection Register Program Flowchart and Pseudo Code](#), for the flowchart for using the Protection Register Program command.

#### Block Lock Command

The Block Lock command is used to lock a block and prevent Program or Erase operations from changing the data in it. All blocks are locked at power-up or reset.

Two Bus Write cycles are required to issue the Block Lock command.

- The first bus cycle sets up the Block Lock command.
- The second Bus Write cycle latches the block address.

The lock status can be monitored for each block using the Read Electronic Signature command. [Table 9.](#) shows the protection status after issuing a Block Lock command.

The Block Lock bits are volatile, once set they remain set until a hardware reset or power-down/power-up. They are cleared by a Blocks Unlock command. Refer to the section, Block Locking, for a detailed explanation.

#### Block Unlock Command

The Blocks Unlock command is used to unlock a block, allowing the block to be programmed or

erased. Two Bus Write cycles are required to issue the Blocks Unlock command.

- The first bus cycle sets up the Block Unlock command.
- The second Bus Write cycle latches the block address.

The lock status can be monitored for each block using the Read Electronic Signature command. [Table 9.](#) shows the protection status after issuing a Block Unlock command. Refer to the section, Block Locking, for a detailed explanation.

#### Block Lock-Down Command

A locked block cannot be Programmed or Erased, or have its protection status changed when  $\overline{WP}$  is low,  $V_{IL}$ . When  $\overline{WP}$  is high,  $V_{IH}$ , the Lock-Down function is disabled and the locked blocks can be individually unlocked by the Block Unlock command.

Two Bus Write cycles are required to issue the Block Lock-Down command.

- The first bus cycle sets up the Block Lock command.
- The second Bus Write cycle latches the block address.

The lock status can be monitored for each block using the Read Electronic Signature command. Locked-Down blocks revert to the locked (and not locked-down) state when the device is reset on power-down. [Table 9.](#) shows the protection status after issuing a Block Lock-Down command. Refer to the section, Block Locking, for a detailed explanation.

## M28W160ECT, M28W160ECB

**Table 3. Commands**

Commands	No. of Cycles	Bus Write Operations								
		1st Cycle			2nd Cycle			3rd Cycle		
		Bus Op.	Addr	Data	Bus Op.	Addr	Data	Bus Op.	Addr	Data
Read Memory Array	1+	Write	X	FFh	Read	Read Addr	Data			
Read Status Register	1+	Write	X	70h	Read	X	Status Register			
Read Electronic Signature	1+	Write	X	90h	Read	Signature Addr (2)	Signature			
Read CFI Query	1+	Write	X	98h	Read	CFI Addr	Query			
Erase	2	Write	X	20h	Write	Block Addr	D0h			
Program	2	Write	X	40h or 10h	Write	Addr	Data Input			
Double Word Program <sup>(3)</sup>	3	Write	X	30h	Write	Addr 1	Data Input	Write	Addr 2	Data Input
Clear Status Register	1	Write	X	50h						
Program/Erase Suspend	1	Write	X	B0h						
Program/Erase Resume	1	Write	X	D0h						
Block Lock	2	Write	X	60h	Write	Block Address	01h			
Block Unlock	2	Write	X	60h	Write	Block Address	D0h			
Block Lock-Down	2	Write	X	60h	Write	Block Address	2Fh			
Protection Register Program	2	Write	X	C0h	Write	Address	Data Input			

Note: 1. X = Don't Care.

2. The signature addresses are listed in Tables 4, 5 and 6.

3. Addr 1 and Addr 2 must be consecutive Addresses differing only for A0.

**Table 4. Read Electronic Signature**

Code	Device	$\bar{E}$	$\bar{G}$	$\bar{W}$	A0	A1	A2-A7	A8-A19	DQ0-DQ7	DQ8-DQ15
Manufacture. Code		V <sub>IL</sub>	V <sub>IL</sub>	V <sub>IH</sub>	V <sub>IL</sub>	V <sub>IL</sub>	0	Don't Care	20h	00h
Device Code	M28W160ECT	V <sub>IL</sub>	V <sub>IL</sub>	V <sub>IH</sub>	V <sub>IH</sub>	V <sub>IL</sub>	0	Don't Care	CEh	88h
	M28W160ECB	V <sub>IL</sub>	V <sub>IL</sub>	V <sub>IH</sub>	V <sub>IH</sub>	V <sub>IL</sub>	0	Don't Care	CFh	88h

Note:  $\bar{R}P = V_{IH}$ .

**Table 5. Read Block Lock Signature**

Block Status	$\bar{E}$	$\bar{G}$	$\bar{W}$	A0	A1	A2-A7	A8-A11	A12-A19	DQ0	DQ1	DQ2-DQ15
Locked Block	V <sub>IL</sub>	V <sub>IL</sub>	V <sub>IH</sub>	V <sub>IL</sub>	V <sub>IH</sub>	0	Don't Care	Block Address	1	0	00h
Unlocked Block	V <sub>IL</sub>	V <sub>IL</sub>	V <sub>IH</sub>	V <sub>IL</sub>	V <sub>IH</sub>	0	Don't Care	Block Address	0	0	00h
Locked-Down Block	V <sub>IL</sub>	V <sub>IL</sub>	V <sub>IH</sub>	V <sub>IL</sub>	V <sub>IH</sub>	0	Don't Care	Block Address	X <sup>(1)</sup>	1	00h

Note: 1. A Locked-Down Block can be locked "DQ0 = 1" or unlocked "DQ0 = 0"; see Block Locking section.

**Table 6. Read Protection Register and Lock Register**

Word	$\bar{E}$	$\bar{G}$	$\bar{W}$	A0-A7	A8-A19	DQ0	DQ1	DQ2	DQ3-DQ7	DQ8-DQ15
Lock	V <sub>IL</sub>	V <sub>IL</sub>	V <sub>IH</sub>	80h	Don't Care	0	OTP Prot. data	Security prot. data	00h	00h
Unique ID 0	V <sub>IL</sub>	V <sub>IL</sub>	V <sub>IH</sub>	81h	Don't Care	ID data	ID data	ID data	ID data	ID data
Unique ID 1	V <sub>IL</sub>	V <sub>IL</sub>	V <sub>IH</sub>	82h	Don't Care	ID data	ID data	ID data	ID data	ID data
Unique ID 2	V <sub>IL</sub>	V <sub>IL</sub>	V <sub>IH</sub>	83h	Don't Care	ID data	ID data	ID data	ID data	ID data
Unique ID 3	V <sub>IL</sub>	V <sub>IL</sub>	V <sub>IH</sub>	84h	Don't Care	ID data	ID data	ID data	ID data	ID data
OTP 0	V <sub>IL</sub>	V <sub>IL</sub>	V <sub>IH</sub>	85h	Don't Care	OTP data	OTP data	OTP data	OTP data	OTP data
OTP 1	V <sub>IL</sub>	V <sub>IL</sub>	V <sub>IH</sub>	86h	Don't Care	OTP data	OTP data	OTP data	OTP data	OTP data
OTP 2	V <sub>IL</sub>	V <sub>IL</sub>	V <sub>IH</sub>	87h	Don't Care	OTP data	OTP data	OTP data	OTP data	OTP data
OTP 3	V <sub>IL</sub>	V <sub>IL</sub>	V <sub>IH</sub>	88h	Don't Care	OTP data	OTP data	OTP data	OTP data	OTP data

**Table 7. Program, Erase Times and Program/Erase Endurance Cycles**

Parameter <sup>(2)</sup>	Test Conditions	M28W160EC			Unit
		Min	Typ <sup>(1)</sup>	Max	
Word Program	V <sub>PP</sub> = V <sub>DD</sub>		10	200	μs
Double Word Program	V <sub>PP</sub> = 12V ±5%		10	200	μs
Main Block Program	V <sub>PP</sub> = 12V ±5%		0.16	5	s
	V <sub>PP</sub> = V <sub>DD</sub>		0.32	5	s
Parameter Block Program	V <sub>PP</sub> = 12V ±5%		0.02	4	s
	V <sub>PP</sub> = V <sub>DD</sub>		0.04	4	s
Main Block Erase	V <sub>PP</sub> = 12V ±5%		1	5	s
	V <sub>PP</sub> = V <sub>DD</sub>		1	5	s
Parameter Block Erase	V <sub>PP</sub> = 12V ±5%		0.4	4	s
	V <sub>PP</sub> = V <sub>DD</sub>		0.4	4	s
Program/Erase Cycles (per Block)		100,000			cycles

Note: 1. Typical values measured at ambient operating temperature, T<sub>A</sub>.  
 2. All the parameters have been sampled only, not 100% tested.

## BLOCK LOCKING

The M28W160EC features an instant, individual block locking scheme that allows any block to be locked or unlocked with no latency. This locking scheme has three levels of protection.

- Lock/Unlock - this first level allows software-only control of block locking.
- Lock-Down - this second level requires hardware interaction before locking can be changed.
- $V_{PP} \leq V_{PPLK}$  - the third level offers a complete hardware protection against program and erase on all blocks.

The lock status of each block can be set to Locked, Unlocked, and Lock-Down. [Table 9.](#), defines all of the possible protection states ( $\overline{WP}$ , DQ1, DQ0), and [APPENDIX C.](#), [Figure 22.](#), shows a flowchart for the locking operations.

### Reading a Block's Lock Status

The lock status of every block can be read in the Read Electronic Signature mode of the device. To enter this mode write 90h to the device. Subsequent reads at the address specified in [Table 5.](#), will output the lock status of that block. The lock status is represented by DQ0 and DQ1. DQ0 indicates the Block Lock/Unlock status and is set by the Lock command and cleared by the Unlock command. It is also automatically set when entering Lock-Down. DQ1 indicates the Lock-Down status and is set by the Lock-Down command. It cannot be cleared by software, only by a hardware reset or power-down.

The following sections explain the operation of the locking system.

### Locked State

The default status of all blocks on power-up or after a hardware reset is Locked (states (0,0,1) or (1,0,1)). Locked blocks are fully protected from any program or erase. Any program or erase operations attempted on a locked block will return an error in the Status Register. The Status of a Locked block can be changed to Unlocked or Lock-Down using the appropriate software commands. An Unlocked block can be Locked by issuing the Lock command.

### Unlocked State

Unlocked blocks (states (0,0,0), (1,0,0) (1,1,0)), can be programmed or erased. All unlocked blocks return to the Locked state after a hardware reset or when the device is powered-down. The status of an unlocked block can be changed to Locked or Locked-Down using the appropriate

software commands. A locked block can be unlocked by issuing the Unlock command.

### Lock-Down State

Blocks that are Locked-Down (state (0,1,x)) are protected from program and erase operations (as for Locked blocks) but their lock status cannot be changed using software commands alone. A Locked or Unlocked block can be Locked-Down by issuing the Lock-Down command. Locked-Down blocks revert to the Locked state when the device is reset or powered-down.

The Lock-Down function is dependent on the  $\overline{WP}$  input pin. When  $\overline{WP}=0$  ( $V_{IL}$ ), the blocks in the Lock-Down state (0,1,x) are protected from program, erase and protection status changes. When  $\overline{WP}=1$  ( $V_{IH}$ ) the Lock-Down function is disabled (1,1,1) and Locked-Down blocks can be individually unlocked to the (1,1,0) state by issuing the software command, where they can be erased and programmed. These blocks can then be locked again (1,1,1) and unlocked (1,1,0) as desired while  $\overline{WP}$  remains high. When  $\overline{WP}$  is low, blocks that were previously Locked-Down return to the Lock-Down state (0,1,x) regardless of any changes made while  $\overline{WP}$  was high. Device reset or power-down resets all blocks, including those in Lock-Down, to the Locked state.

### Locking Operations During Erase Suspend

Changes to block lock status can be performed during an erase suspend by using the standard locking command sequences to unlock, lock or lock-down a block. This is useful in the case when another block needs to be updated while an erase operation is in progress.

To change block locking during an erase operation, first write the Erase Suspend command, then check the status register until it indicates that the erase operation has been suspended. Next write the desired Lock command sequence to a block and the protection status will be changed. After completing any desired lock, read, or program operations, resume the erase operation with the Erase Resume command.

If a block is locked or locked-down during an erase suspend of the same block, the locking status bits will be changed immediately, but when the erase is resumed, the erase operation will complete.

Locking operations cannot be performed during a program suspend. Refer to [APPENDIX D.](#), [COMMAND INTERFACE AND PROGRAM/ERASE CONTROLLER STATE](#), for detailed information on which commands are valid during erase suspend.

Table 8. Block Lock Status

Item	Address	Data
Block Lock Configuration	xx002	LOCK
Block is Unlocked		DQ0=0
Block is Locked		DQ0=1
Block is Locked-Down		DQ1=1

Table 9. Protection Status

Current Protection Status <sup>(1)</sup> ( $\overline{WP}$ , DQ1, DQ0)		Next Protection Status <sup>(1)</sup> ( $\overline{WP}$ , DQ1, DQ0)			
Current State	Program/Erase Allowed	After Block Lock Command	After Block Unlock Command	After Block Lock-Down Command	After $\overline{WP}$ transition
1,0,0	yes	1,0,1	1,0,0	1,1,1	0,0,0
1,0,1 <sup>(2)</sup>	no	1,0,1	1,0,0	1,1,1	0,0,1
1,1,0	yes	1,1,1	1,1,0	1,1,1	0,1,1
1,1,1	no	1,1,1	1,1,0	1,1,1	0,1,1
0,0,0	yes	0,0,1	0,0,0	0,1,1	1,0,0
0,0,1 <sup>(2)</sup>	no	0,0,1	0,0,0	0,1,1	1,0,1
0,1,1	no	0,1,1	0,1,1	0,1,1	1,1,1 or 1,1,0 <sup>(3)</sup>

Note: 1. The protection status is defined by the write protect pin and by DQ1 ('1' for a locked-down block) and DQ0 ('1' for a locked block) as read in the Read Electronic Signature command with A1 = V<sub>IH</sub> and A0 = V<sub>IL</sub>.

2. All blocks are locked at power-up, so the default configuration is 001 or 101 according to  $\overline{WP}$  status.

3. A  $\overline{WP}$  transition to V<sub>IH</sub> on a locked block will restore the previous DQ0 value, giving a 111 or 110.

## STATUS REGISTER

The Status Register provides information on the current or previous Program or Erase operation. The various bits convey information and errors on the operation. To read the Status register the Read Status Register command can be issued, refer to Read Status Register Command section. To output the contents, the Status Register is latched on the falling edge of the Chip Enable or Output Enable signals, and can be read until Chip Enable or Output Enable returns to  $V_{IH}$ . Either Chip Enable or Output Enable must be toggled to update the latched data.

Bus Read operations from any address always read the Status Register during Program and Erase operations.

The bits in the Status Register are summarized in [Table 10., Status Register Bits](#). Refer to [Table 10.](#) in conjunction with the following text descriptions.

**Program/Erase Controller Status (Bit 7).** The Program/Erase Controller Status bit indicates whether the Program/Erase Controller is active or inactive. When the Program/Erase Controller Status bit is Low (set to '0'), the Program/Erase Controller is active; when the bit is High (set to '1'), the Program/Erase Controller is inactive, and the device is ready to process a new command.

The Program/Erase Controller Status is Low immediately after a Program/Erase Suspend command is issued until the Program/Erase Controller pauses. After the Program/Erase Controller pauses the bit is High.

During Program, Erase, operations the Program/Erase Controller Status bit can be polled to find the end of the operation. Other bits in the Status Register should not be tested until the Program/Erase Controller completes the operation and the bit is High.

After the Program/Erase Controller completes its operation the Erase Status, Program Status,  $V_{PP}$  Status and Block Lock Status bits should be tested for errors.

**Erase Suspend Status (Bit 6).** The Erase Suspend Status bit indicates that an Erase operation has been suspended or is going to be suspended. When the Erase Suspend Status bit is High (set to '1'), a Program/Erase Suspend command has been issued and the memory is waiting for a Program/Erase Resume command.

The Erase Suspend Status should only be considered valid when the Program/Erase Controller Status bit is High (Program/Erase Controller inactive). Bit 7 is set within 30 $\mu$ s of the Program/Erase Suspend command being issued therefore the memory may still complete the operation rather than entering the Suspend mode.

When a Program/Erase Resume command is issued the Erase Suspend Status bit returns Low.

**Erase Status (Bit 5).** The Erase Status bit can be used to identify if the memory has failed to verify that the block has erased correctly. When the Erase Status bit is High (set to '1'), the Program/Erase Controller has applied the maximum number of pulses to the block and still failed to verify that the block has erased correctly. The Erase Status bit should be read once the Program/Erase Controller Status bit is High (Program/Erase Controller inactive).

Once set High, the Erase Status bit can only be reset Low by a Clear Status Register command or a hardware reset. If set High it should be reset before a new Program or Erase command is issued, otherwise the new command will appear to fail.

**Program Status (Bit 4).** The Program Status bit is used to identify a Program failure. When the Program Status bit is High (set to '1'), the Program/Erase Controller has applied the maximum number of pulses to the byte and still failed to verify that it has programmed correctly. The Program Status bit should be read once the Program/Erase Controller Status bit is High (Program/Erase Controller inactive).

Once set High, the Program Status bit can only be reset Low by a Clear Status Register command or a hardware reset. If set High it should be reset before a new command is issued, otherwise the new command will appear to fail.

**$V_{PP}$  Status (Bit 3).** The  $V_{PP}$  Status bit can be used to identify an invalid voltage on the  $V_{PP}$  pin during Program and Erase operations. The  $V_{PP}$  pin is only sampled at the beginning of a Program or Erase operation. Indeterminate results can occur if  $V_{PP}$  becomes invalid during an operation.

When the  $V_{PP}$  Status bit is Low (set to '0'), the voltage on the  $V_{PP}$  pin was sampled at a valid voltage; when the  $V_{PP}$  Status bit is High (set to '1'), the  $V_{PP}$  pin has a voltage that is below the  $V_{PP}$  Lockout Voltage,  $V_{PPLK}$ , the memory is protected and Program and Erase operations cannot be performed.

Once set High, the  $V_{PP}$  Status bit can only be reset Low by a Clear Status Register command or a hardware reset. If set High it should be reset before a new Program or Erase command is issued, otherwise the new command will appear to fail.

**Program Suspend Status (Bit 2).** The Program Suspend Status bit indicates that a Program operation has been suspended. When the Program Suspend Status bit is High (set to '1'), a Program/Erase Suspend command has been issued and the memory is waiting for a Program/Erase Resume command. The Program Suspend Status should only be considered valid when the Pro-

gram/Erase Controller Status bit is High (Program/Erase Controller inactive). Bit 2 is set within 5 $\mu$ s of the Program/Erase Suspend command being issued therefore the memory may still complete the operation rather than entering the Suspend mode. When a Program/Erase Resume command is issued the Program Suspend Status bit returns Low.

**Block Protection Status (Bit 1).** The Block Protection Status bit can be used to identify if a Program or Erase operation has tried to modify the contents of a locked block.

When the Block Protection Status bit is High (set to '1'), a Program or Erase operation has been attempted on a locked block.

Once set High, the Block Protection Status bit can only be reset Low by a Clear Status Register command or a hardware reset. If set High it should be reset before a new command is issued, otherwise the new command will appear to fail.

**Reserved (Bit 0).** Bit 0 of the Status Register is reserved. Its value must be masked.

**Note:** Refer to [APPENDIX C.](#), Flowcharts and Pseudo Codes, for using the Status Register.

**Table 10. Status Register Bits**

Bit	Name	Logic Level	Definition
7	P/E.C. Status	'1'	Ready
		'0'	Busy
6	Erase Suspend Status	'1'	Suspended
		'0'	In progress or Completed
5	Erase Status	'1'	Erase Error
		'0'	Erase Success
4	Program Status	'1'	Program Error
		'0'	Program Success
3	V <sub>PP</sub> Status	'1'	V <sub>PP</sub> Invalid, Abort
		'0'	V <sub>PP</sub> OK
2	Program Suspend Status	'1'	Suspended
		'0'	In Progress or Completed
1	Block Protection Status	'1'	Program/Erase on protected Block, Abort
		'0'	No operation to protected blocks
0	Reserved		

Note: Logic level '1' is High, '0' is Low.

**MAXIMUM RATING**

Stressing the device above the rating listed in the Absolute Maximum Ratings table may cause permanent damage to the device. These are stress ratings only and operation of the device at these or any other conditions above those indicated in the

Operating sections of this specification is not implied. Exposure to Absolute Maximum Rating conditions for extended periods may affect device reliability. Refer also to the Numonyx SURE Program and other relevant quality documents.

**Table 11. Absolute Maximum Ratings**

Symbol	Parameter	Value		Unit
		Min	Max	
T <sub>A</sub>	Ambient Operating Temperature <sup>(1)</sup>	- 40	85	°C
T <sub>BIAS</sub>	Temperature Under Bias	- 40	125	°C
T <sub>STG</sub>	Storage Temperature	- 55	155	°C
V <sub>IO</sub>	Input or Output Voltage	- 0.6	V <sub>DDQ</sub> +0.6	V
V <sub>DD</sub> , V <sub>DDQ</sub>	Supply Voltage	- 0.6	4.1	V
V <sub>PP</sub>	Program Voltage	- 0.6	13	V

Note: 1. Depending on range.

### DC AND AC PARAMETERS

This section summarizes the operating and measurement conditions, and the DC and AC characteristics of the device. The parameters in the DC and AC characteristics Tables that follow, are derived from tests performed under the Measure-

ment Conditions summarized in [Table 12., Operating and AC Measurement Conditions](#). Designers should check that the operating conditions in their circuit match the measurement conditions when relying on the quoted parameters.

**Table 12. Operating and AC Measurement Conditions**

Parameter	M28W160ECT, M28W160ECB								Units
	70		85		90		100		
	Min	Max	Min	Max	Min	Max	Min	Max	
V <sub>DD</sub> Supply Voltage	2.7	3.6	2.7	3.6	2.7	3.6	2.7	3.6	V
V <sub>DDQ</sub> Supply Voltage (V <sub>DDQ</sub> ≤ V <sub>DD</sub> )	2.7	3.6	2.7	3.6	2.7	3.6	1.65	3.6	V
Ambient Operating Temperature	- 40	85	- 40	85	- 40	85	- 40	85	°C
Load Capacitance (C <sub>L</sub> )	50		50		50		50		pF
Input Rise and Fall Times		5		5		5		5	ns
Input Pulse Voltages	0 to V <sub>DDQ</sub>		0 to V <sub>DDQ</sub>		0 to V <sub>DDQ</sub>		0 to V <sub>DDQ</sub>		V
Input and Output Timing Ref. Voltages	V <sub>DDQ</sub> /2		V <sub>DDQ</sub> /2		V <sub>DDQ</sub> /2		V <sub>DDQ</sub> /2		V

**Figure 7. AC Measurement I/O Waveform**

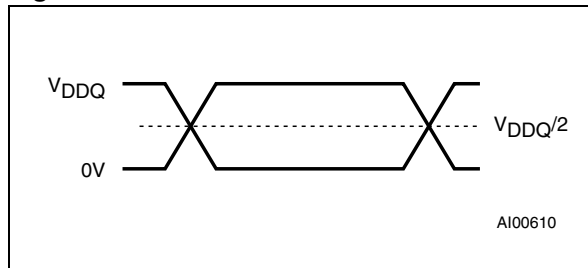

**Figure 8. AC Measurement Load Circuit**

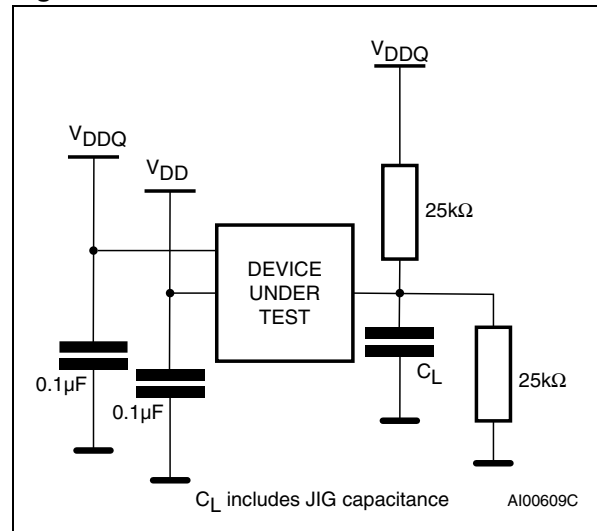

**Table 13. Capacitance**

Symbol	Parameter	Test Condition	Min	Max	Unit
C <sub>IN</sub>	Input Capacitance	V <sub>IN</sub> = 0V		6	pF
C <sub>OUT</sub>	Output Capacitance	V <sub>OUT</sub> = 0V		12	pF

Note: Sampled only, not 100% tested.

**Table 14. DC Characteristics**

Symbol	Parameter	Test Condition	Min	Typ	Max	Unit
I <sub>LI</sub>	Input Leakage Current	0V ≤ V <sub>IN</sub> ≤ V <sub>DDQ</sub>			±1	μA
I <sub>LO</sub>	Output Leakage Current	0V ≤ V <sub>OUT</sub> ≤ V <sub>DDQ</sub>			±10	μA
I <sub>DD</sub>	Supply Current (Read)	$\bar{E} = V_{SS}, \bar{G} = V_{IH}, f = 5\text{MHz}$		9	18	mA
I <sub>DD1</sub>	Supply Current (Stand-by or Automatic Stand-by)	$\bar{E} = V_{DDQ} \pm 0.2\text{V},$ $\bar{R}\bar{P} = V_{DDQ} \pm 0.2\text{V}$		15	50	μA
I <sub>DD2</sub>	Supply Current (Reset)	$\bar{R}\bar{P} = V_{SS} \pm 0.2\text{V}$		15	50	μA
I <sub>DD3</sub>	Supply Current (Program)	Program in progress V <sub>PP</sub> = 12V ± 5%		5	10	mA
		Program in progress V <sub>PP</sub> = V <sub>DD</sub>		10	20	mA
I <sub>DD4</sub>	Supply Current (Erase)	Erase in progress V <sub>PP</sub> = 12V ± 5%		5	20	mA
		Erase in progress V <sub>PP</sub> = V <sub>DD</sub>		10	20	mA
I <sub>DD5</sub>	Supply Current (Program/Erase Suspend)	$\bar{E} = V_{DDQ} \pm 0.2\text{V},$ Erase suspended		15	50	μA
I <sub>PP</sub>	Program Current (Read or Stand-by)	V <sub>PP</sub> > V <sub>DD</sub>			400	μA
I <sub>PP1</sub>	Program Current (Read or Stand-by)	V <sub>PP</sub> ≤ V <sub>DD</sub>		1	5	μA
I <sub>PP2</sub>	Program Current (Reset)	$\bar{R}\bar{P} = V_{SS} \pm 0.2\text{V}$		1	5	μA
I <sub>PP3</sub>	Program Current (Program)	Program in progress V <sub>PP</sub> = 12V ± 5%		1	10	mA
		Program in progress V <sub>PP</sub> = V <sub>DD</sub>		1	5	μA
I <sub>PP4</sub>	Program Current (Erase)	Erase in progress V <sub>PP</sub> = 12V ± 5%		3	10	mA
		Erase in progress V <sub>PP</sub> = V <sub>DD</sub>		1	5	μA
V <sub>IL</sub>	Input Low Voltage		-0.5		0.4	V
		V <sub>DDQ</sub> ≥ 2.7V	-0.5		0.8	V
V <sub>IH</sub>	Input High Voltage		V <sub>DDQ</sub> - 0.4		V <sub>DDQ</sub> + 0.4	V
		V <sub>DDQ</sub> ≥ 2.7V	0.7 V <sub>DDQ</sub>		V <sub>DDQ</sub> + 0.4	V
V <sub>OL</sub>	Output Low Voltage	I <sub>OL</sub> = 100μA, V <sub>DD</sub> = V <sub>DD</sub> min, V <sub>DDQ</sub> = V <sub>DDQ</sub> min			0.1	V
V <sub>OH</sub>	Output High Voltage	I <sub>OH</sub> = -100μA, V <sub>DD</sub> = V <sub>DD</sub> min, V <sub>DDQ</sub> = V <sub>DDQ</sub> min	V <sub>DDQ</sub> - 0.1			V
V <sub>PP1</sub>	Program Voltage (Program or Erase operations)		1.65		3.6	V
V <sub>PPH</sub>	Program Voltage (Program or Erase operations)		11.4		12.6	V
V <sub>PPLK</sub>	Program Voltage (Program and Erase lock-out)				1	V
V <sub>LKO</sub>	V <sub>DD</sub> Supply Voltage (Program and Erase lock-out)				2	V

Figure 9. Read Mode AC Waveforms

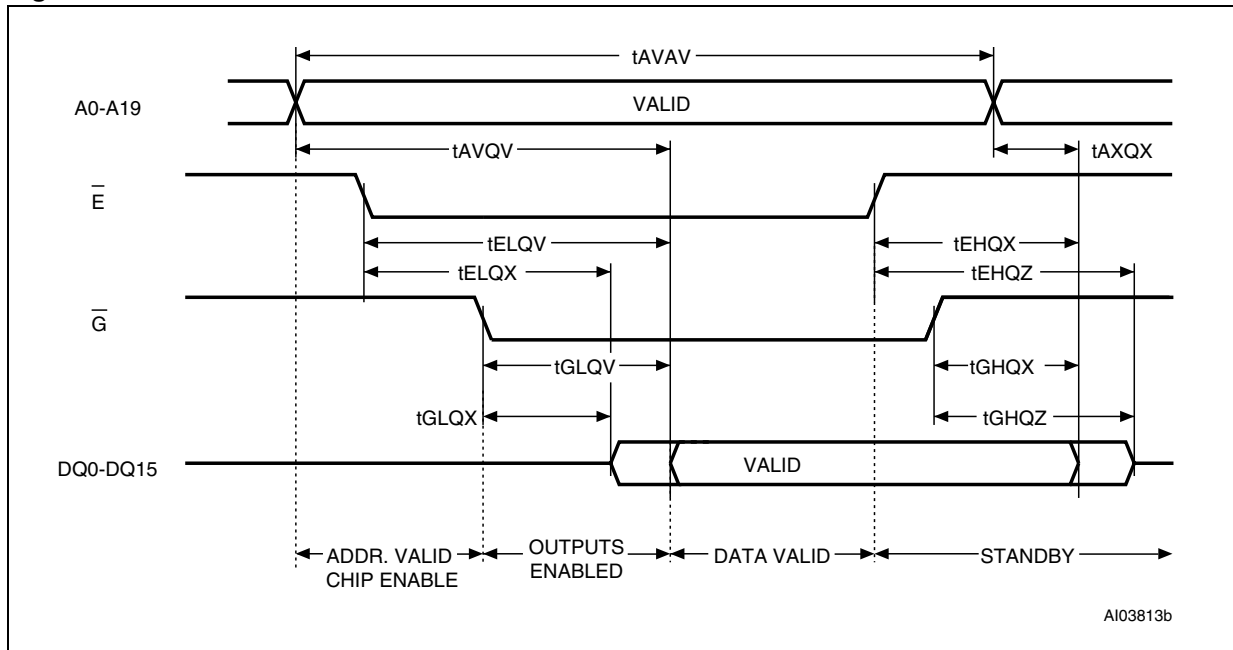

Table 15. Read AC Characteristics

Symbol	Alt	Parameter		M28W160EC				Unit
				70	85	90	100	
$t_{AVAV}$	$t_{RC}$	Address Valid to Next Address Valid	Min	70	85	90	100	ns
$t_{AVQV}$	$t_{ACC}$	Address Valid to Output Valid	Max	70	85	90	100	ns
$t_{AXQX}^{(1)}$	$t_{OH}$	Address Transition to Output Transition	Min	0	0	0	0	ns
$t_{EHQX}^{(1)}$	$t_{OH}$	Chip Enable High to Output Transition	Min	0	0	0	0	ns
$t_{EHQZ}^{(1)}$	$t_{HZ}$	Chip Enable High to Output Hi-Z	Max	20	20	25	30	ns
$t_{ELQV}^{(2)}$	$t_{CE}$	Chip Enable Low to Output Valid	Max	70	85	90	100	ns
$t_{ELQX}^{(1)}$	$t_{LZ}$	Chip Enable Low to Output Transition	Min	0	0	0	0	ns
$t_{GHQX}^{(1)}$	$t_{OH}$	Output Enable High to Output Transition	Min	0	0	0	0	ns
$t_{GHQZ}^{(1)}$	$t_{DF}$	Output Enable High to Output Hi-Z	Max	20	20	25	30	ns
$t_{GLQV}^{(2)}$	$t_{OE}$	Output Enable Low to Output Valid	Max	20	20	30	35	ns
$t_{GLQX}^{(1)}$	$t_{OLZ}$	Output Enable Low to Output Transition	Min	0	0	0	0	ns

Note: 1. Sampled only, not 100% tested.

2.  $\bar{G}$  may be delayed by up to  $t_{ELQV} - t_{GLQV}$  after the falling edge of  $\bar{E}$  without increasing  $t_{ELQV}$ .

Figure 10. Write AC Waveforms, Write Enable Controlled

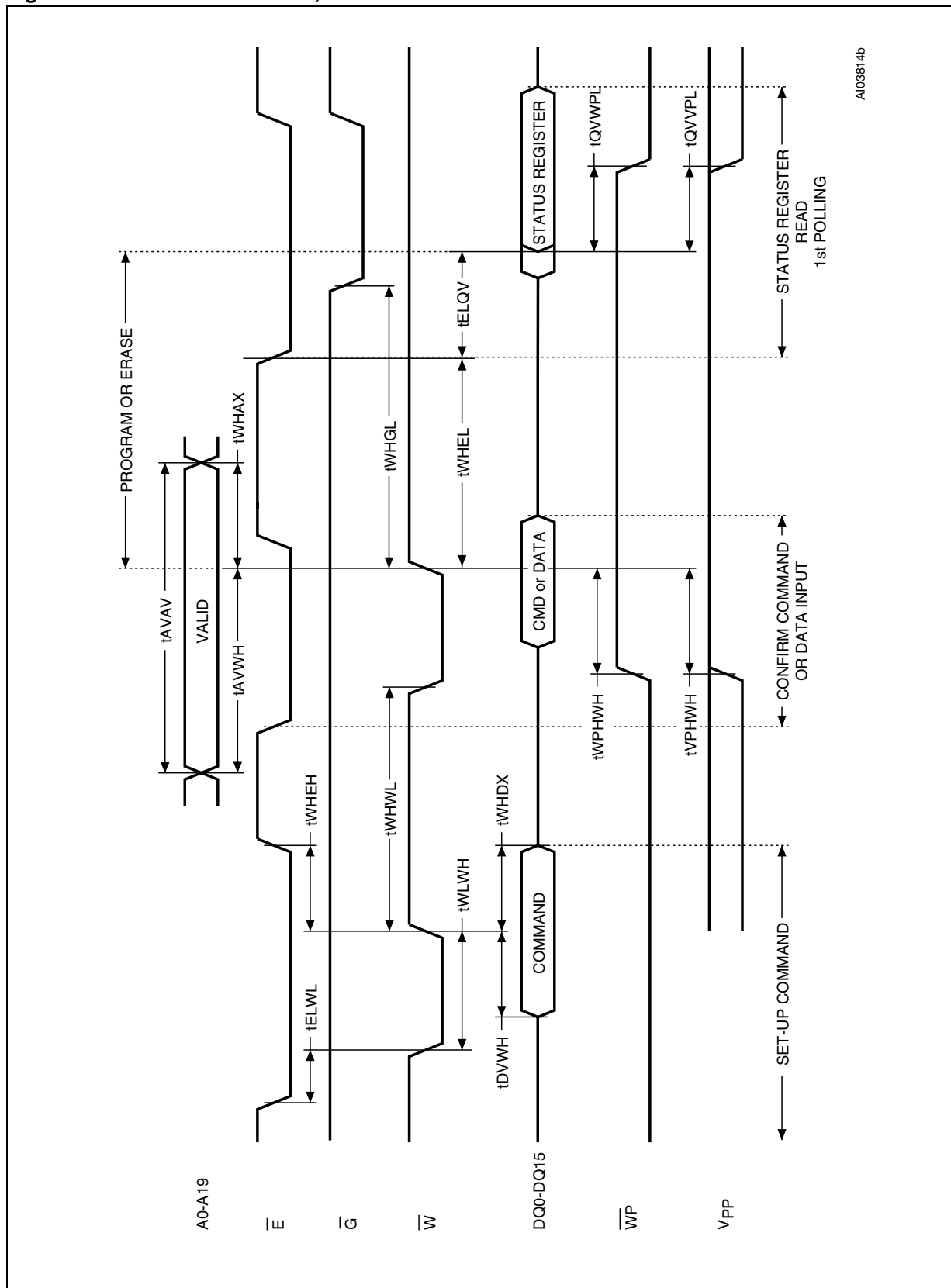

Table 16. Write AC Characteristics, Write Enable Controlled

Symbol	Alt	Parameter		M28W160EC				Unit
				70	85	90	100	
t <sub>AVAV</sub>	t <sub>WC</sub>	Write Cycle Time	Min	70	85	90	100	ns
t <sub>AVWH</sub>	t <sub>AS</sub>	Address Valid to Write Enable High	Min	45	45	50	50	ns
t <sub>DVWH</sub>	t <sub>DS</sub>	Data Valid to Write Enable High	Min	45	45	50	50	ns
t <sub>ELWL</sub>	t <sub>CS</sub>	Chip Enable Low to Write Enable Low	Min	0	0	0	0	ns
t <sub>ELQV</sub>		Chip Enable Low to Output Valid	Min	70	85	90	100	ns
t <sub>QVVPL</sub> <sup>(1,2)</sup>		Output Valid to V <sub>PP</sub> Low	Min	0	0	0	0	ns
t <sub>QVWPL</sub>		Output Valid to Write Protect Low	Min	0	0	0	0	ns
t <sub>VPHWH</sub> <sup>(1)</sup>	t <sub>VPS</sub>	V <sub>PP</sub> High to Write Enable High	Min	200	200	200	200	ns
t <sub>WHAX</sub>	t <sub>AH</sub>	Write Enable High to Address Transition	Min	0	0	0	0	ns
t <sub>WHDX</sub>	t <sub>DH</sub>	Write Enable High to Data Transition	Min	0	0	0	0	ns
t <sub>WHEH</sub>	t <sub>CH</sub>	Write Enable High to Chip Enable High	Min	0	0	0	0	ns
t <sub>WHEL</sub>		Write Enable High to Chip Enable Low	Min	25	25	30	30	ns
t <sub>WHGL</sub>		Write Enable High to Output Enable Low	Min	20	20	30	30	ns
t <sub>WHWL</sub>	t <sub>WPH</sub>	Write Enable High to Write Enable Low	Min	25	25	30	30	ns
t <sub>WLWH</sub>	t <sub>WP</sub>	Write Enable Low to Write Enable High	Min	45	45	50	50	ns
t <sub>WPHWH</sub>		Write Protect High to Write Enable High	Min	45	45	50	50	ns

Note: 1. Sampled only, not 100% tested.

2. Applicable if V<sub>PP</sub> is seen as a logic input (V<sub>PP</sub> < 3.6V).

Figure 11. Write AC Waveforms, Chip Enable Controlled

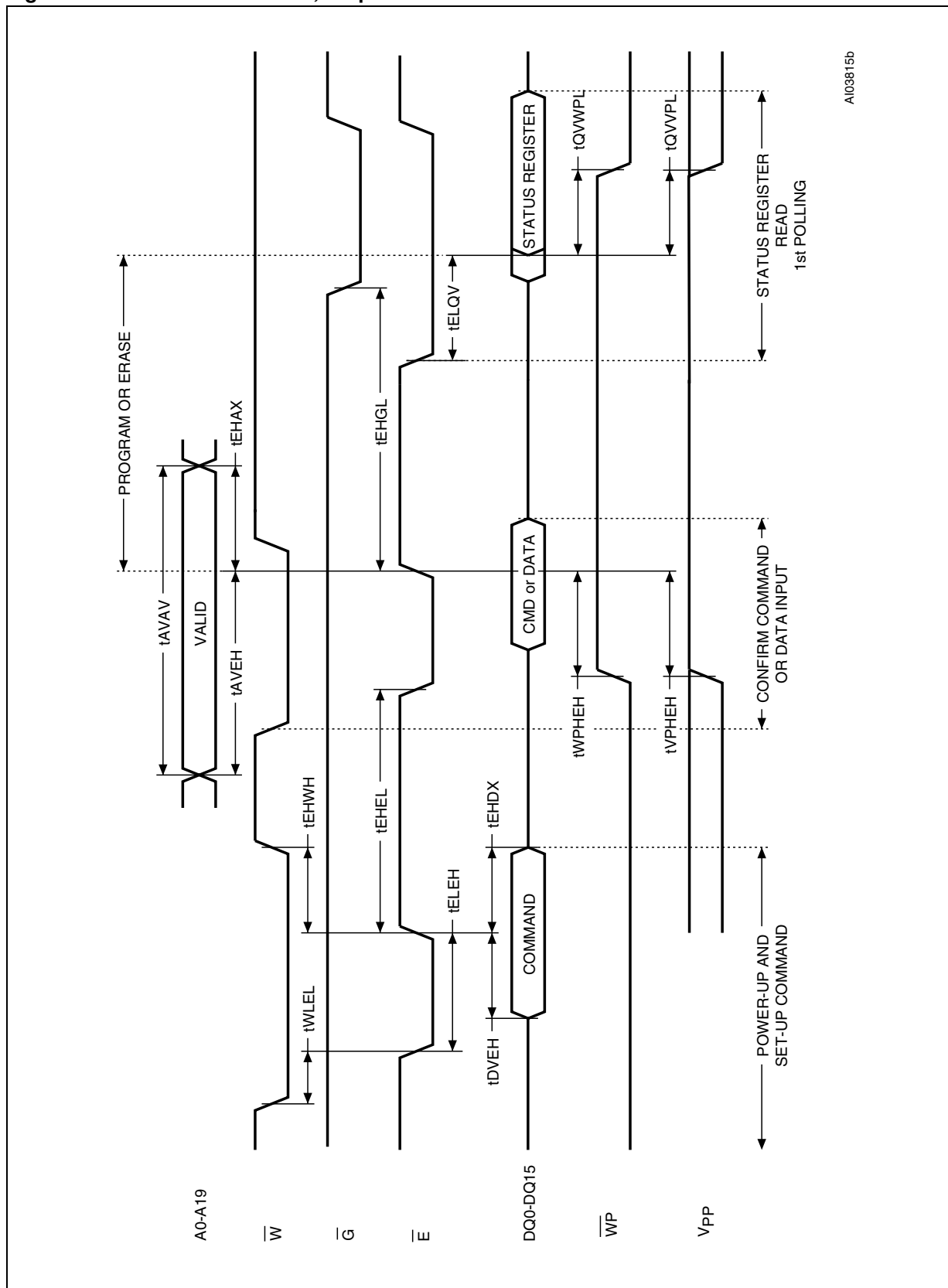

A103815b

Table 17. Write AC Characteristics, Chip Enable Controlled

Symbol	Alt	Parameter		M28W160EC				Unit
				70	85	90	100	
t <sub>AVAV</sub>	t <sub>WC</sub>	Write Cycle Time	Min	70	85	90	100	ns
t <sub>AVEH</sub>	t <sub>AS</sub>	Address Valid to Chip Enable High	Min	45	45	50	50	ns
t <sub>DVEH</sub>	t <sub>DS</sub>	Data Valid to Chip Enable High	Min	45	45	50	50	ns
t <sub>EHAX</sub>	t <sub>AH</sub>	Chip Enable High to Address Transition	Min	0	0	0	0	ns
t <sub>EHDX</sub>	t <sub>DH</sub>	Chip Enable High to Data Transition	Min	0	0	0	0	ns
t <sub>EHEL</sub>	t <sub>CPH</sub>	Chip Enable High to Chip Enable Low	Min	25	25	30	30	ns
t <sub>EHGL</sub>		Chip Enable High to Output Enable Low	Min	25	25	30	30	ns
t <sub>EHWH</sub>	t <sub>WH</sub>	Chip Enable High to Write Enable High	Min	0	0	0	0	ns
t <sub>ELEH</sub>	t <sub>CP</sub>	Chip Enable Low to Chip Enable High	Min	45	45	50	50	ns
t <sub>ELQV</sub>		Chip Enable Low to Output Valid	Min	70	85	90	100	ns
t <sub>QVVP L</sub> <sup>(1,2)</sup>		Output Valid to V <sub>PP</sub> Low	Min	0	0	0	0	ns
t <sub>QVWPL</sub>		Data Valid to Write Protect Low	Min	0	0	0	0	ns
t <sub>VPHEH</sub> <sup>(1)</sup>	t <sub>VPS</sub>	V <sub>PP</sub> High to Chip Enable High	Min	200	200	200	200	ns
t <sub>WLEL</sub>	t <sub>CS</sub>	Write Enable Low to Chip Enable Low	Min	0	0	0	0	ns
t <sub>WPHEH</sub>		Write Protect High to Chip Enable High	Min	45	45	50	50	ns

Note: 1. Sampled only, not 100% tested.

2. Applicable if V<sub>PP</sub> is seen as a logic input (V<sub>PP</sub> < 3.6V).

Figure 12. Power-Up and Reset AC Waveforms

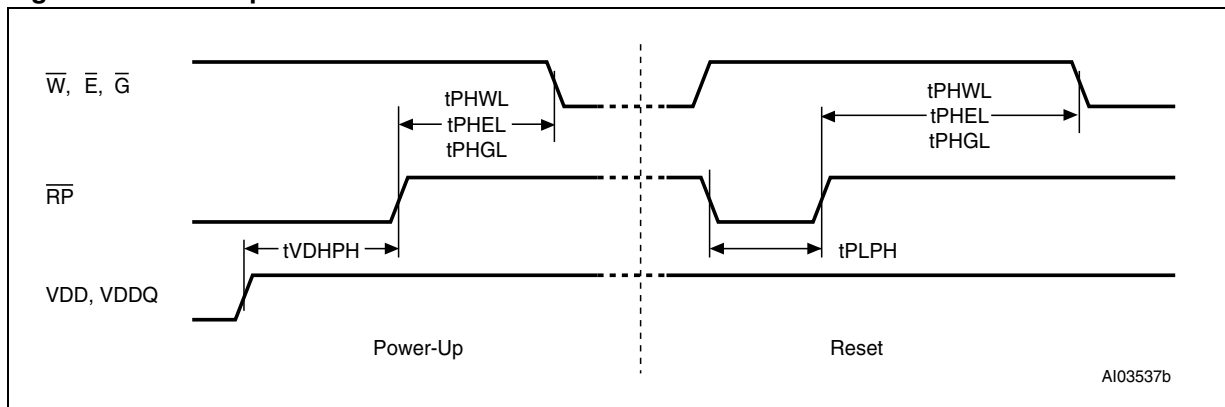

Table 18. Power-Up and Reset AC Characteristics

Symbol	Parameter	Test Condition		M28W160EC				Unit
				70	85	90	100	
t <sub>PHWL</sub> t <sub>PHEL</sub> t <sub>PHGL</sub>	Reset High to Write Enable Low, Chip Enable Low, Output Enable Low	During Program and Erase	Min	50	50	50	50	μs
		others	Min	30	30	30	30	ns
t <sub>PLPH</sub> <sup>(1,2)</sup>	Reset Low to Reset High		Min	100	100	100	100	ns
t <sub>VDHPH</sub> <sup>(3)</sup>	Supply Voltages High to Reset High		Min	50	50	50	50	μs

Note: 1. The device Reset is possible but not guaranteed if t<sub>PLPH</sub> < 100ns.

2. Sampled only, not 100% tested.

3. It is important to assert  $\overline{RP}$  in order to allow proper CPU initialization during power up or reset.

PACKAGE MECHANICAL

Figure 13. TSOP48 - 48 lead Plastic Thin Small Outline, 12 x 20mm, Package Outline

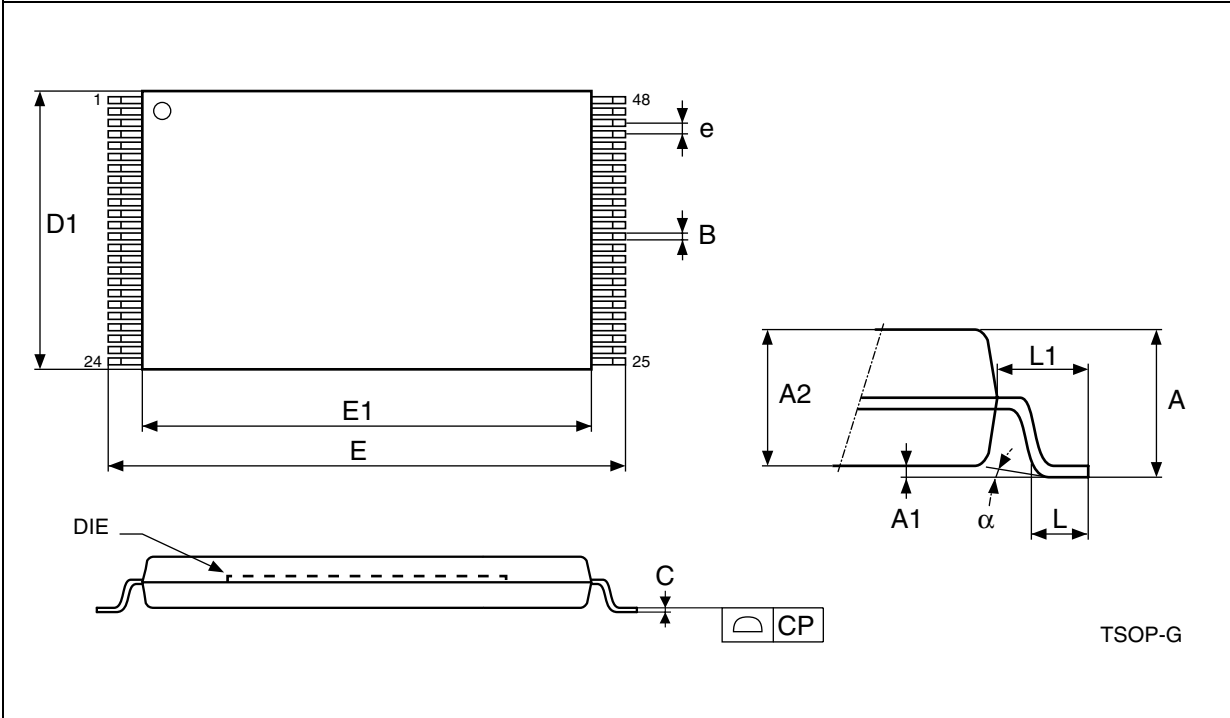

Note: Drawing is not to scale.

Table 19. TSOP48 - 48 lead Plastic Thin Small Outline, 12 x 20mm, Package Mechanical Data

Symbol	millimeters			inches		
	Typ	Min	Max	Typ	Min	Max
A			1.200			0.0472
A1	0.100	0.050	0.150	0.0039	0.0020	0.0059
A2	1.000	0.950	1.050	0.0394	0.0374	0.0413
B	0.220	0.170	0.270	0.0087	0.0067	0.0106
C		0.100	0.210		0.0039	0.0083
CP			0.100			0.0039
D1	12.000	11.900	12.100	0.4724	0.4685	0.4764
E	20.000	19.800	20.200	0.7874	0.7795	0.7953
E1	18.400	18.300	18.500	0.7244	0.7205	0.7283
e	0.500	-	-	0.0197	-	-
L	0.600	0.500	0.700	0.0236	0.0197	0.0276
L1	0.800			0.0315		
a	3	0	5	3	0	5

**M28W160ECT, M28W160ECB**

**Figure 14. TFBGA46 6.39x6.37mm - 8x6 ball array, 0.75mm pitch, Bottom View Package Outline**

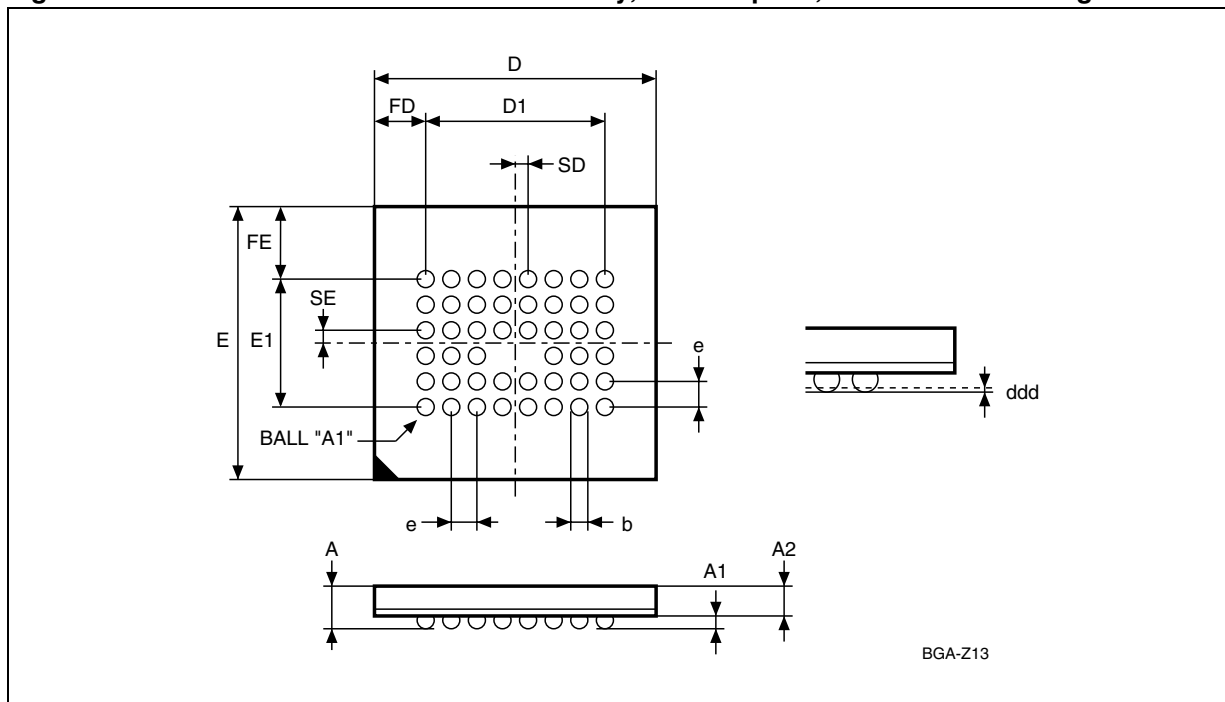

Drawing is not to scale.

**Table 20. TFBGA46 6.39x6.37mm - 8x6 ball array, 0.75mm pitch, Package Mechanical Data**

Symbol	millimeters			inches		
	Typ	Min	Max	Typ	Min	Max
A			1.200			0.0472
A1		0.200			0.0079	
A2			1.000			0.0394
b	0.400	0.350	0.450	0.0157	0.0138	0.0177
D	6.390	6.290	6.490	0.2516	0.2476	0.2555
D1	5.250	-	-	0.2067	-	-
ddd			0.100			0.0039
E	6.370	6.270	6.470	0.2508	0.2469	0.2547
e	0.750	-	-	0.0295	-	-
E1	3.750	-	-	0.1476	-	-
FD	0.570	-	-	0.0224	-	-
FE	1.310	-	-	0.0516	-	-
SD	0.375	-	-	0.0148	-	-
SE	0.375	-	-	0.0148	-	-

Figure 15. TFBGA46 Daisy Chain - Package Connections (Top view through package)

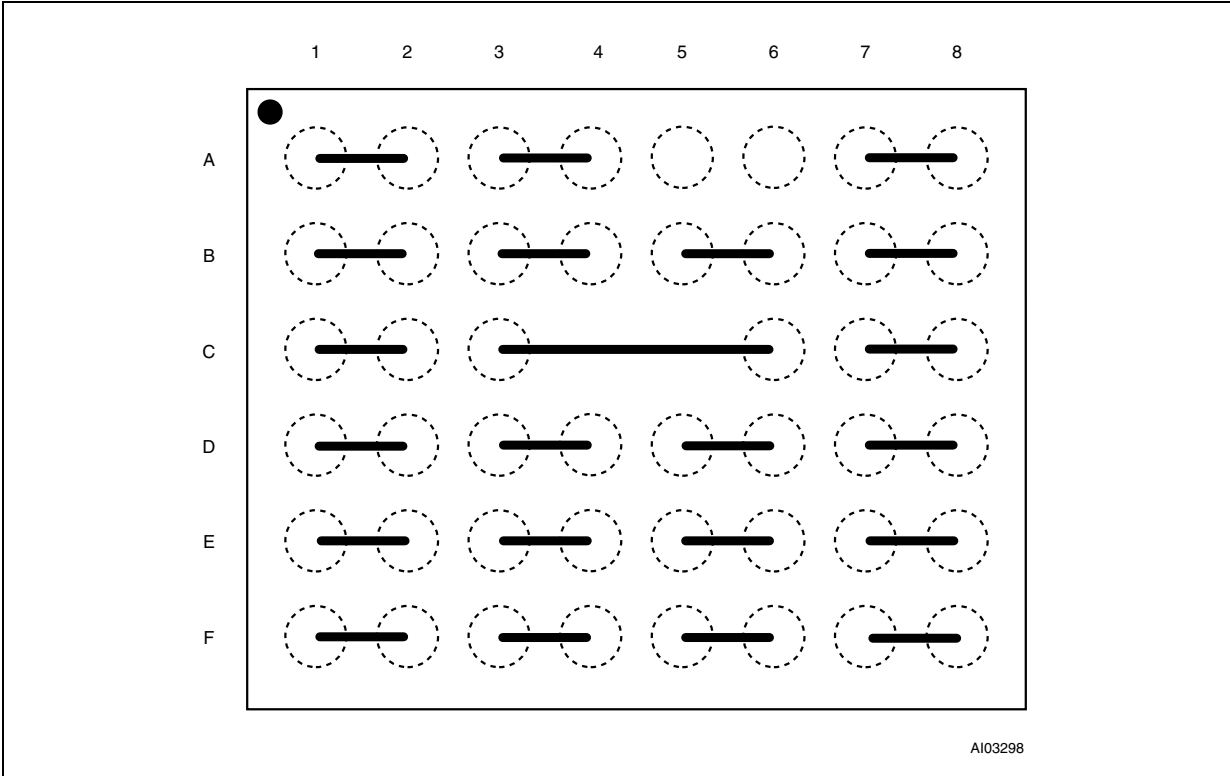
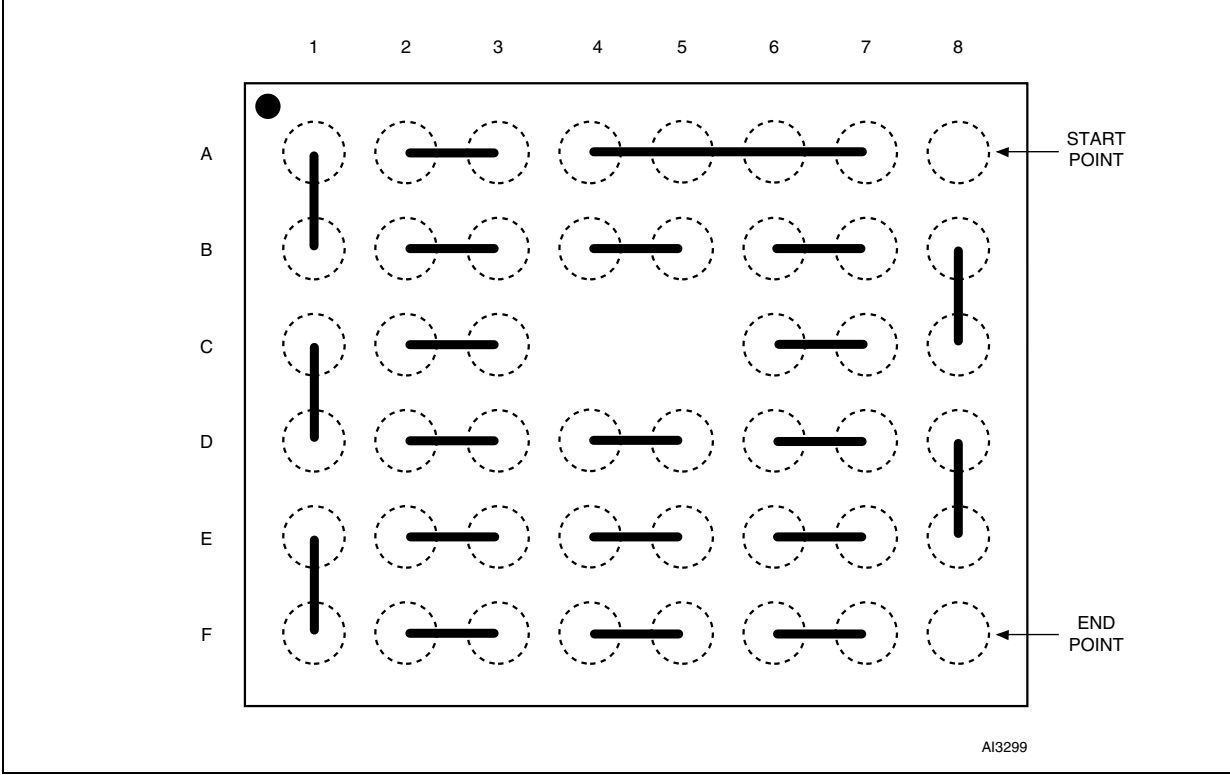

Figure 16. TFBGA46 Daisy Chain - PCB Connections proposal (Top view through package)



**PART NUMBERING**

**Table 21. Ordering Information Scheme**

Example:	M28W160ECT	90	N	6	T
<b>Device Type</b> M28					
<b>Operating Voltage</b> W = V <sub>DD</sub> = 2.7V to 3.6V; V <sub>DDQ</sub> = 1.65V to 3.6V					
<b>Device Function</b> 160EC = 16 Mbit (1 Mb x16), Boot Block					
<b>Array Matrix</b> T = Top Boot B = Bottom Boot					
<b>Speed</b> 70 = 70 ns 85 = 85 ns 90 = 90 ns 100 = 100 ns					
<b>Package</b> N = TSOP48: 12 x 20 mm ZB = TFBGA46: 6.39 x 6.37mm, 0.75 mm pitch					
<b>Temperature Range</b> 1 = 0 to 70 °C 6 = -40 to 85 °C					
<b>Option</b> Blank = Standard Packing T = Tape & Reel Packing S = Tape & Reel Packing, 16mm (BGA only) E = ECOPACK Package, Standard Packing F = ECOPACK Package, Tape & Reel Packing U = ECOPACK Package, 16mm Tape & Reel Packing (BGA only)					

Table 22. Daisy Chain Ordering Scheme

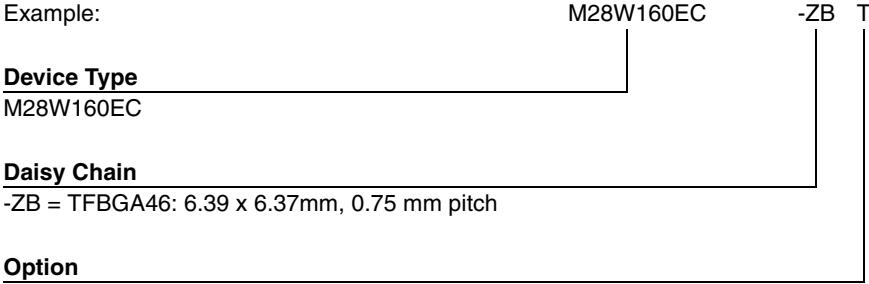

**Device Type**

M28W160EC

**Daisy Chain**

-ZB = TFBGA46: 6.39 x 6.37mm, 0.75 mm pitch

**Option**

T = Tape & Reel Packing

S = Tape & Reel Packing, 16mm (BGA only)

Devices are shipped from the factory with the memory content bits erased to '1'. For a list of available options (Speed, Package, etc.) or for further information on any aspect of this device, please contact the Numonyx Sales Office nearest to you.

**APPENDIX A. BLOCK ADDRESS TABLES**

**Table 23. Top Boot Block Addresses, M28W160ECT**

#	Size (KWord)	Address Range
0	4	FF000-FFFFF
1	4	FE000-FEFFF
2	4	FD000-FDFFF
3	4	FC000-FCFFF
4	4	FB000-FBFFF
5	4	FA000-FAFFF
6	4	F9000-F9FFF
7	4	F8000-F8FFF
8	32	F0000-F7FFF
99	32	E8000-EFFFF
10	32	E0000-E7FFF
11	32	D8000-D7FFF
12	32	D0000-D7FFF
13	32	C8000-CFFFF
14	32	C0000-C7FFF
15	32	B8000-BFFFF
16	32	B0000-B7FFF
17	32	A8000-AFFFF
18	32	A0000-A7FFF
19	32	98000-9FFFF
20	32	90000-97FFF
21	32	88000-8FFFF
22	32	80000-87FFF
23	32	78000-7FFFF
24	32	70000-77FFF
25	32	68000-6FFFF
26	32	60000-67FFF
27	32	58000-5FFFF
28	32	50000-57FFF
29	32	48000-4FFFF
30	32	40000-47FFF
31	32	38000-3FFFF
32	32	30000-37FFF
33	32	28000-2FFFF
34	32	20000-27FFF
35	32	18000-1FFFF
36	32	10000-17FFF
37	32	08000-0FFFF
38	32	00000-07FFF

**Table 24. Bottom Boot Block Addresses, M28W160ECB**

#	Size (KWord)	Address Range
38	32	F8000-FFFFF
37	32	F0000-F7FFF
36	32	E8000-EFFFF
35	32	E0000-E7FFF
34	32	D8000-D7FFF
33	32	D0000-D7FFF
32	32	C8000-CFFFF
31	32	C0000-C7FFF
30	32	B8000-BFFFF
29	32	B0000-B7FFF
28	32	A8000-AFFFF
27	32	A0000-A7FFF
26	32	98000-9FFFF
25	32	90000-97FFF
24	32	88000-8FFFF
23	32	80000-87FFF
22	32	78000-7FFFF
21	32	70000-77FFF
20	32	68000-6FFFF
19	32	60000-67FFF
18	32	58000-5FFFF
17	32	50000-57FFF
16	32	48000-4FFFF
15	32	40000-47FFF
14	32	38000-3FFFF
13	32	30000-37FFF
12	32	28000-2FFFF
11	32	20000-27FFF
10	32	18000-1FFFF
9	32	10000-17FFF
8	32	08000-0FFFF
7	4	07000-07FFF
6	4	06000-06FFF
5	4	05000-05FFF
4	4	04000-04FFF
3	4	03000-03FFF
2	4	02000-02FFF
1	4	01000-01FFF
0	4	00000-00FFF

## APPENDIX B. COMMON FLASH INTERFACE (CFI)

The Common Flash Interface is a JEDEC approved, standardized data structure that can be read from the Flash memory device. It allows a system software to query the device to determine various electrical and timing parameters, density information and functions supported by the memory. The system can interface easily with the device, enabling the software to upgrade itself when necessary.

When the CFI Query Command (RCFI) is issued the device enters CFI Query mode and the data

structure is read from the memory. Tables 25, 26, 27, 28, 29 and 30 show the addresses used to retrieve the data.

The CFI data structure also contains a security area where a 64 bit unique security number is written (see Table 30., Security Code Area). This area can be accessed only in Read mode by the final user. It is impossible to change the security number after it has been written by Numonyx. Issue a Read command to return to Read mode.

**Table 25. Query Structure Overview**

Offset	Sub-section Name	Description
00h	Reserved	Reserved for algorithm-specific information
10h	CFI Query Identification String	Command set ID and algorithm data offset
1Bh	System Interface Information	Device timing & voltage information
27h	Device Geometry Definition	Flash device layout
P	Primary Algorithm-specific Extended Query table	Additional information specific to the Primary Algorithm (optional)
A	Alternate Algorithm-specific Extended Query table	Additional information specific to the Alternate Algorithm (optional)

Note: Query data are always presented on the lowest order data outputs.

**Table 26. CFI Query Identification String**

Offset	Data	Description	Value
00h	0020h	Manufacturer Code	Numonyx
01h	88CEh 88CFh	Device Code	Top Bottom
02h-0Fh	reserved	Reserved	
10h	0051h	Query Unique ASCII String "QRY"	"Q"
11h	0052h		"R"
12h	0059h		"Y"
13h	0003h	Primary Algorithm Command Set and Control Interface ID code 16 bit ID code defining a specific algorithm	Intel compatible
14h	0000h		
15h	0035h	Address for Primary Algorithm extended Query table (see Table 28.)	P = 35h
16h	0000h		
17h	0000h	Alternate Vendor Command Set and Control Interface ID Code second vendor - specified algorithm supported (0000h means none exists)	NA
18h	0000h		
19h	0000h	Address for Alternate Algorithm extended Query table (0000h means none exists)	NA
1Ah	0000h		

Note: Query data are always presented on the lowest order data outputs (DQ7-DQ0) only. DQ8-DQ15 are '0'.

**Table 27. CFI Query System Interface Information**

Offset	Data	Description	Value
1Bh	0027h	V <sub>DD</sub> Logic Supply Minimum Program/Erase or Write voltage bit 7 to 4BCD value in volts bit 3 to 0BCD value in 100 mV	2.7V
1Ch	0036h	V <sub>DD</sub> Logic Supply Maximum Program/Erase or Write voltage bit 7 to 4BCD value in volts bit 3 to 0BCD value in 100 mV	3.6V
1Dh	00B4h	V <sub>PP</sub> [Programming] Supply Minimum Program/Erase voltage bit 7 to 4HEX value in volts bit 3 to 0BCD value in 100 mV	11.4V
1Eh	00C6h	V <sub>PP</sub> [Programming] Supply Maximum Program/Erase voltage bit 7 to 4HEX value in volts bit 3 to 0BCD value in 100 mV	12.6V
1Fh	0004h	Typical time-out per single word program = 2 <sup>n</sup> μs	16μs
20h	0004h	Typical time-out for Double Word Program = 2 <sup>n</sup> μs	16μs
21h	000Ah	Typical time-out per individual block erase = 2 <sup>n</sup> ms	1s
22h	0000h	Typical time-out for full chip erase = 2 <sup>n</sup> ms	NA
23h	0005h	Maximum time-out for word program = 2 <sup>n</sup> times typical	512μs
24h	0005h	Maximum time-out for Double Word Program = 2 <sup>n</sup> times typical	512μs
25h	0003h	Maximum time-out per individual block erase = 2 <sup>n</sup> times typical	8s
26h	0000h	Maximum time-out for chip erase = 2 <sup>n</sup> times typical	NA

Table 28. Device Geometry Definition

Offset Word Mode	Data	Description	Value
27h	0015h	Device Size = $2^n$ in number of bytes	2 MByte
28h 29h	0001h 0000h	Flash Device Interface Code description	x16 Async.
2Ah 2Bh	0002h 0000h	Maximum number of bytes in multi-byte program or page = $2^n$	4
2Ch	0002h	Number of Erase Block Regions within the device. It specifies the number of regions within the device containing contiguous Erase Blocks of the same size.	2
M28W160ECT	2Dh 2Eh	Region 1 Information Number of identical-size erase block = 001Eh+1	31
	2Fh 30h	Region 1 Information Block size in Region 1 = 0100h * 256 byte	64 KByte
	31h 32h	Region 2 Information Number of identical-size erase block = 0007h+1	8
	33h 34h	Region 2 Information Block size in Region 2 = 0020h * 256 byte	8 KByte
M28W160ECB	2Dh 2Eh	Region 1 Information Number of identical-size erase block = 0007h+1	8
	2Fh 30h	Region 1 Information Block size in Region 1 = 0020h * 256 byte	8 KByte
	31h 32h	Region 2 Information Number of identical-size erase block = 001Eh+1	31
	33h 34h	Region 2 Information Block size in Region 2 = 0100h * 256 byte	64 KByte

**Table 29. Primary Algorithm-Specific Extended Query Table**

Offset P = 35h (1)	Data	Description	Value
(P+0)h = 35h	0050h	Primary Algorithm extended Query table unique ASCII string "PRI"	"P"
(P+1)h = 36h	0052h		"R"
(P+2)h = 37h	0049h		"I"
(P+3)h = 38h	0031h	Major version number, ASCII	"1"
(P+4)h = 39h	0030h	Minor version number, ASCII	"0"
(P+5)h = 3Ah	0066h	Extended Query table contents for Primary Algorithm. Address (P+5)h contains less significant byte. bit 0Chip Erase supported(1 = Yes, 0 = No) bit 1Suspend Erase supported(1 = Yes, 0 = No) bit 2Suspend Program supported(1 = Yes, 0 = No) bit 3Legacy Lock/Unlock supported(1 = Yes, 0 = No) bit 4Queued Erase supported(1 = Yes, 0 = No) bit 5Instant individual block locking supported(1 = Yes, 0 = No) bit 6Protection bits supported(1 = Yes, 0 = No) bit 7Page mode read supported(1 = Yes, 0 = No) bit 8Synchronous read supported(1 = Yes, 0 = No) bit 31 to 9Reserved; undefined bits are '0'	No
(P+6)h = 3Bh	0000h		Yes
(P+7)h = 3Ch	0000h		Yes
(P+8)h = 3Dh	0000h		No
(P+9)h = 3Eh	0001h	Supported Functions after Suspend Read Array, Read Status Register and CFI Query are always supported during Erase or Program operation bit 0Program supported after Erase Suspend (1 = Yes, 0 = No) bit 7 to 1Reserved; undefined bits are '0'	Yes
(P+A)h = 3Fh	0003h	Block Lock Status Defines which bits in the Block Status Register section of the Query are implemented. Address (P+A)h contains less significant byte bit 0Block Lock Status Register Lock/Unlock bit active(1 = Yes, 0 = No) bit 1Block Lock Status Register Lock-Down bit active (1 = Yes, 0 = No) bit 15 to 2Reserved for future use; undefined bits are '0'	Yes
(P+B)h = 40h	0000h		Yes
(P+C)h = 41h	0030h	V <sub>DD</sub> Logic Supply Optimum Program/Erase voltage (highest performance) bit 7 to 4HEX value in volts bit 3 to 0BCD value in 100 mV	3V
(P+D)h = 42h	00C0h	V <sub>PP</sub> Supply Optimum Program/Erase voltage bit 7 to 4HEX value in volts bit 3 to 0BCD value in 100 mV	12V
(P+E)h = 43h	0001h	Number of Protection register fields in JEDEC ID space. "00h," indicates that 256 protection bytes are available	01
(P+F)h = 44h	0080h	Protection Field 1: Protection Description This field describes user-available. One Time Programmable (OTP) Protection register bytes. Some are pre-programmed with device unique serial numbers. Others are user programmable. Bits 0–15 point to the Protection register Lock byte, the section's first byte. The following bytes are factory pre-programmed and user-programmable. bit 0 to 7 Lock/bytes JEDEC-plane physical low address bit 8 to 15Lock/bytes JEDEC-plane physical high address bit 16 to 23 "n" such that 2 <sup>n</sup> = factory pre-programmed bytes bit 24 to 31 "n" such that 2 <sup>n</sup> = user programmable bytes	80h
(P+10)h = 45h	0000h		00h
(P+11)h = 46h	0003h		8 Byte
(P+12)h = 47h	0003h		8 Byte
(P+13)h = 48h		Reserved	

Note: 1. See Table 26., offset 15 for P pointer definition.

**Table 30. Security Code Area**

Offset	Data	Description
80h	00XX	Protection Register Lock
81h	XXXX	64 bits: unique device number
82h	XXXX	
83h	XXXX	
84h	XXXX	
85h	XXXX	64 bits: User Programmable OTP
86h	XXXX	
87h	XXXX	
88h	XXXX	

APPENDIX C. FLOWCHARTS AND PSEUDO CODES

Figure 17. Program Flowchart and Pseudo Code

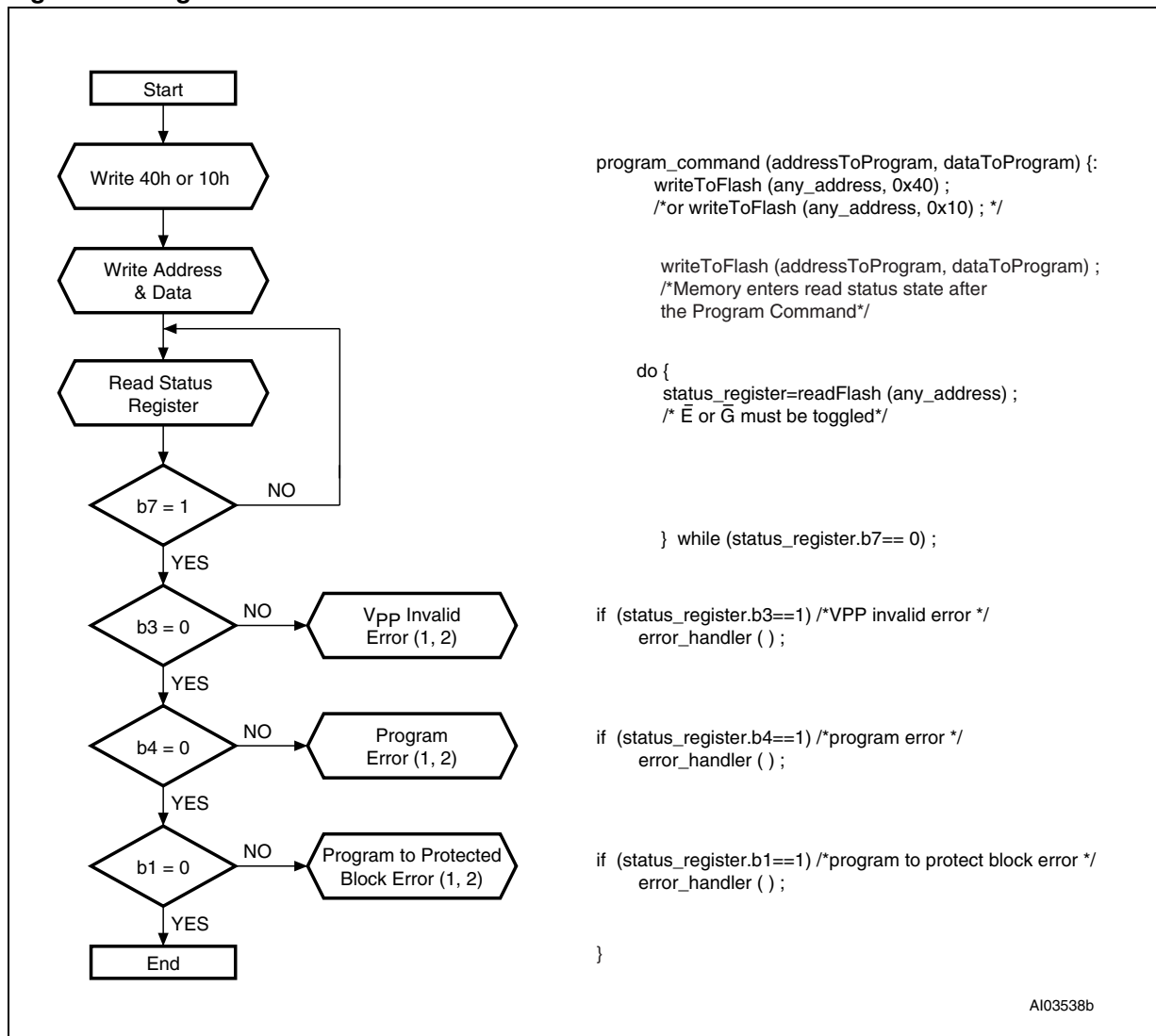

Note: 1. Status check of b1 (Protected Block), b3 (VPP Invalid) and b4 (Program Error) can be made after each program operation or after a sequence.  
 2. If an error is found, the Status Register must be cleared before further Program/Erase Controller operations.

Figure 18. Double Word Program Flowchart and Pseudo Code

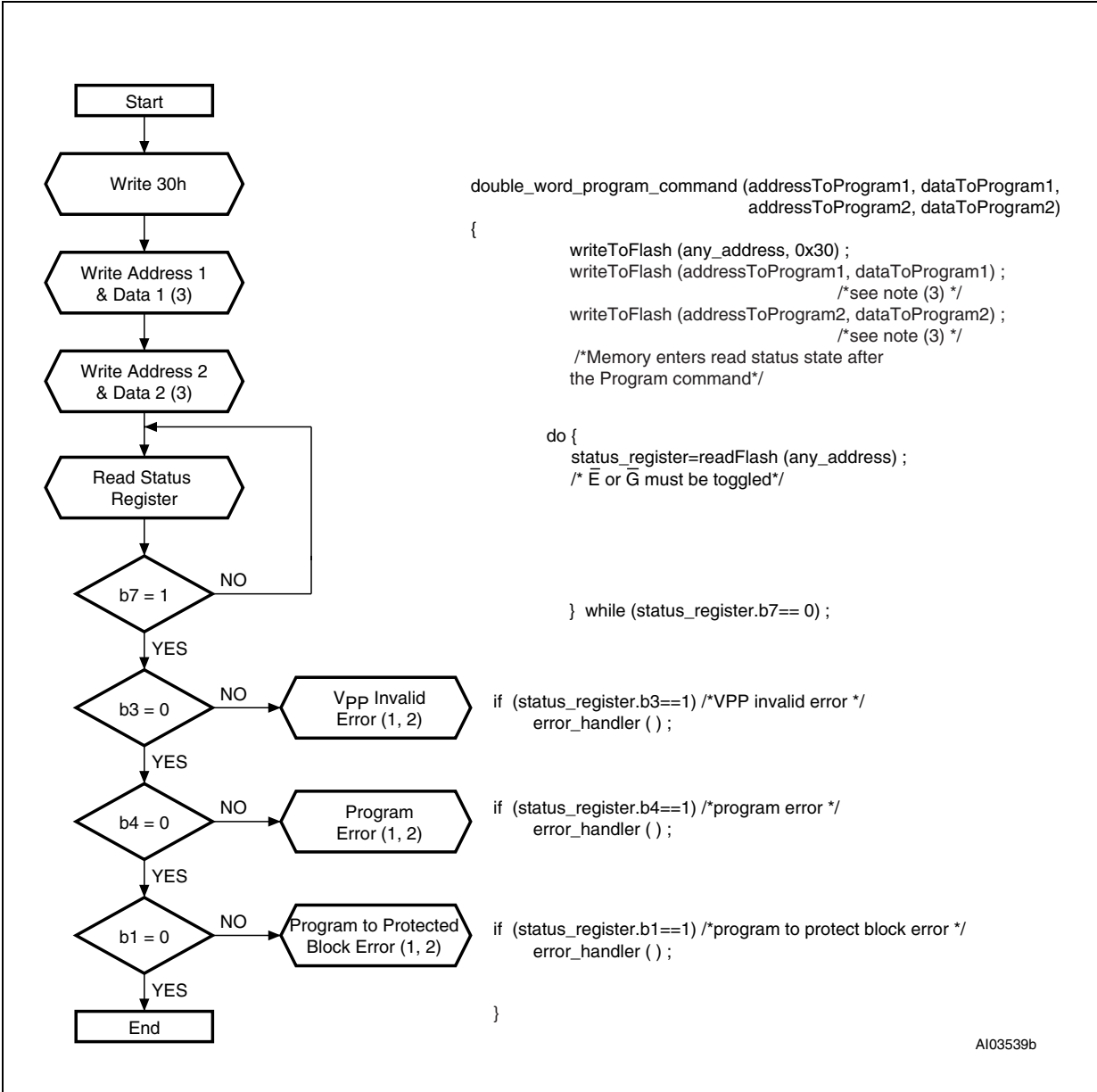

Note: 1. Status check of b1 (Protected Block), b3 (VPP Invalid) and b4 (Program Error) can be made after each program operation or after a sequence.  
 2. If an error is found, the Status Register must be cleared before further Program/Erase operations.  
 3. Address 1 and Address 2 must be consecutive addresses differing only for bit A0.

Figure 19. Program Suspend & Resume Flowchart and Pseudo Code

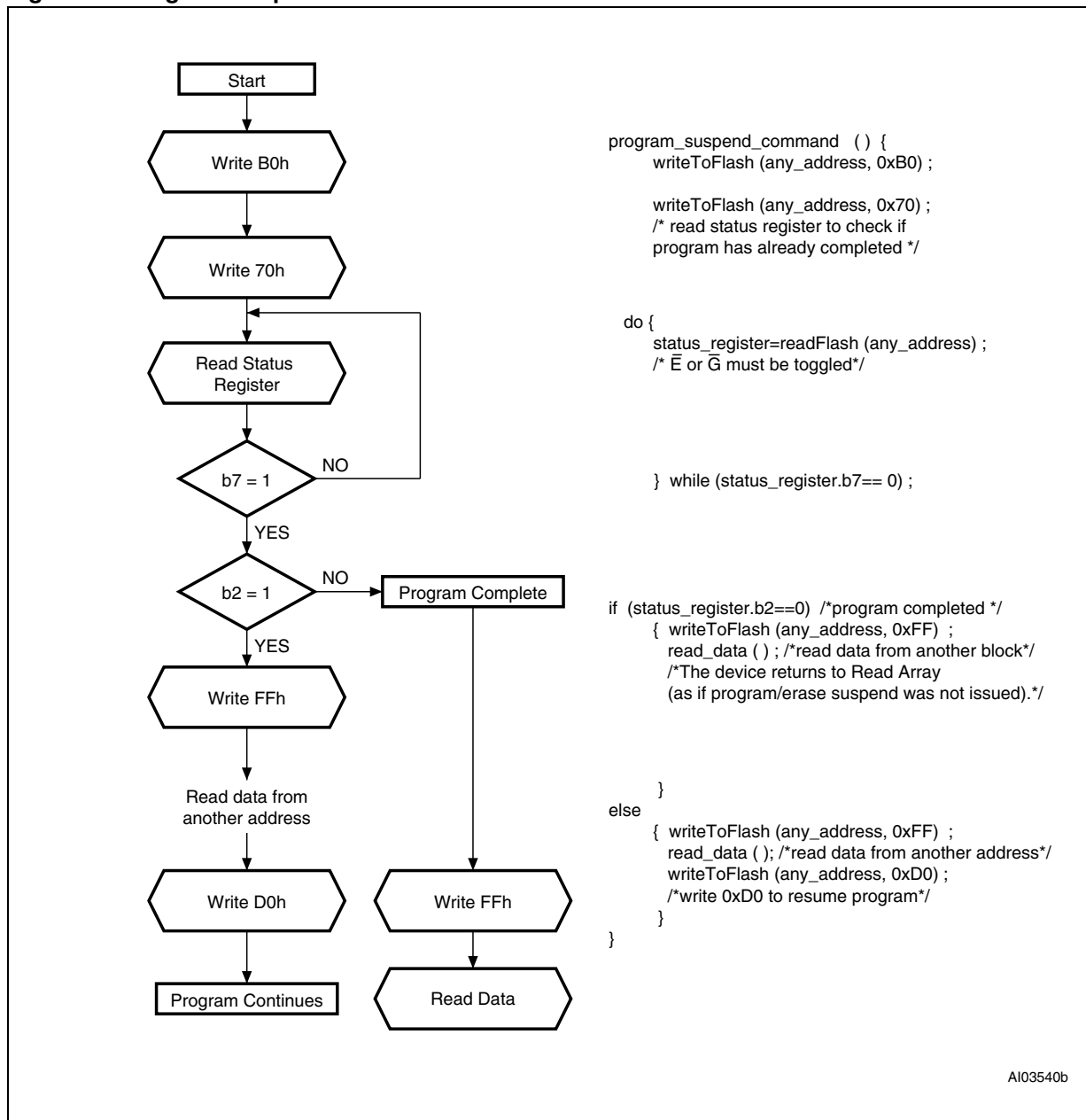
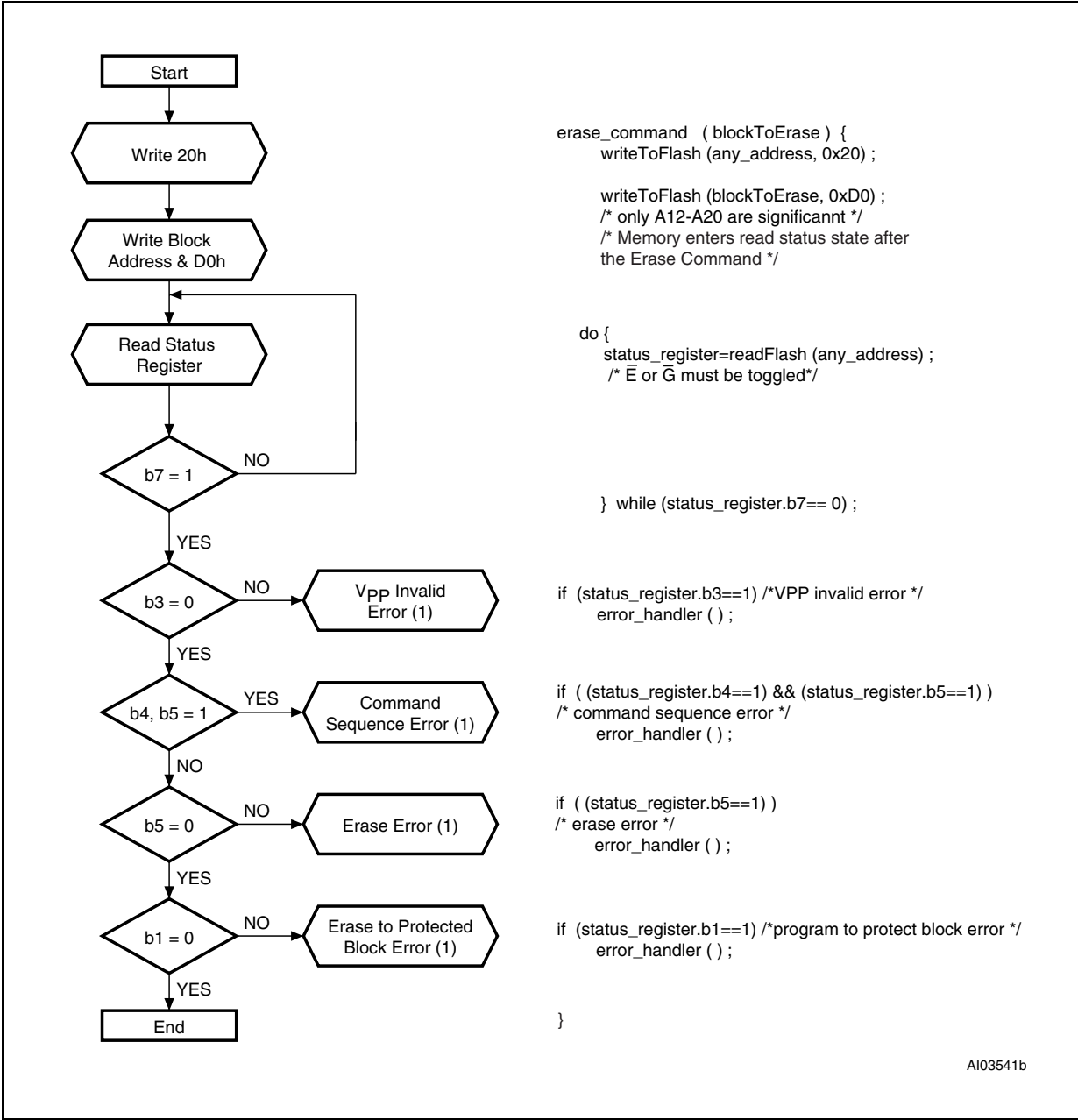

Figure 20. Erase Flowchart and Pseudo Code



Note: If an error is found, the Status Register must be cleared before further Program/Erase operations.

Figure 21. Erase Suspend & Resume Flowchart and Pseudo Code

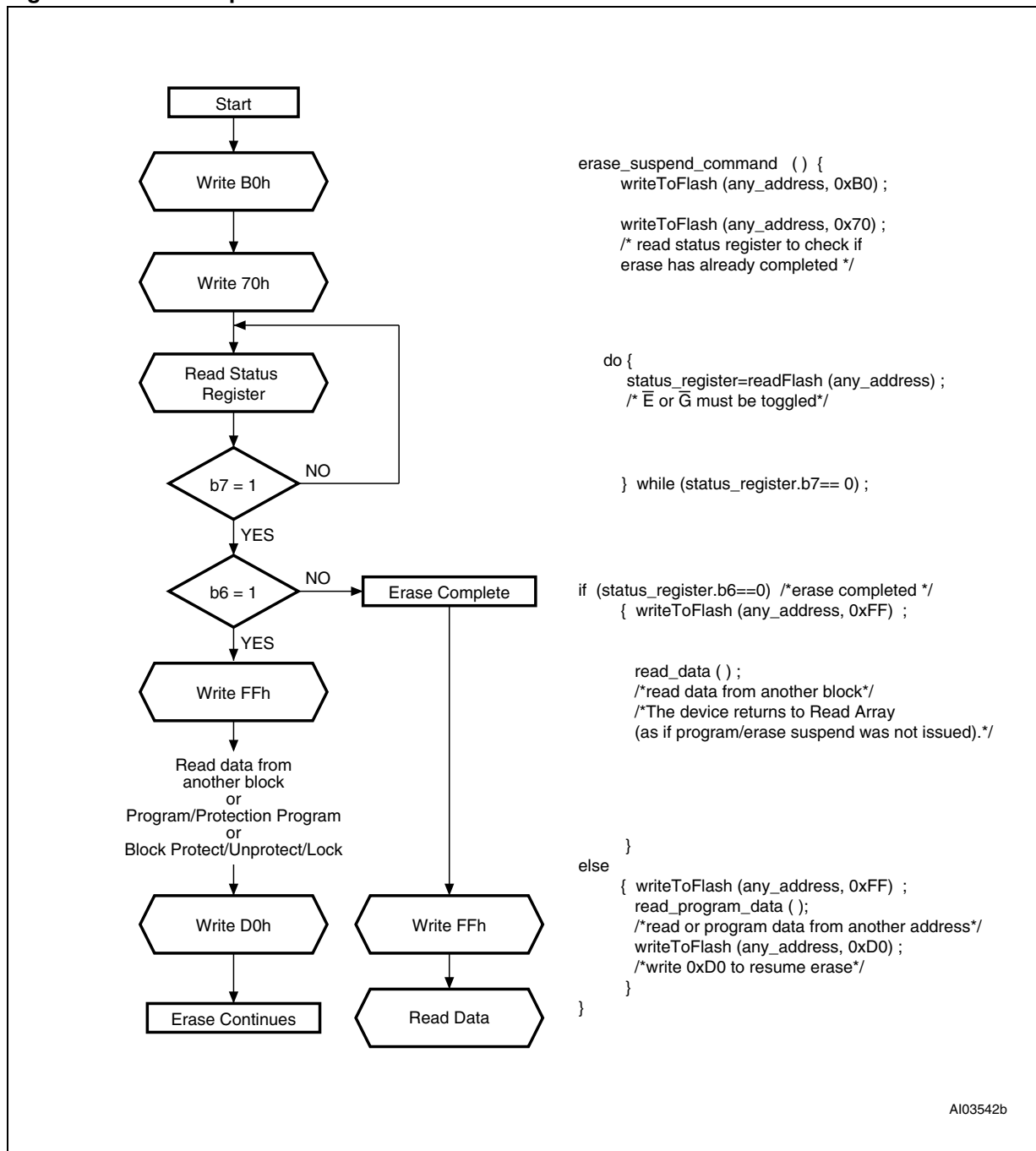
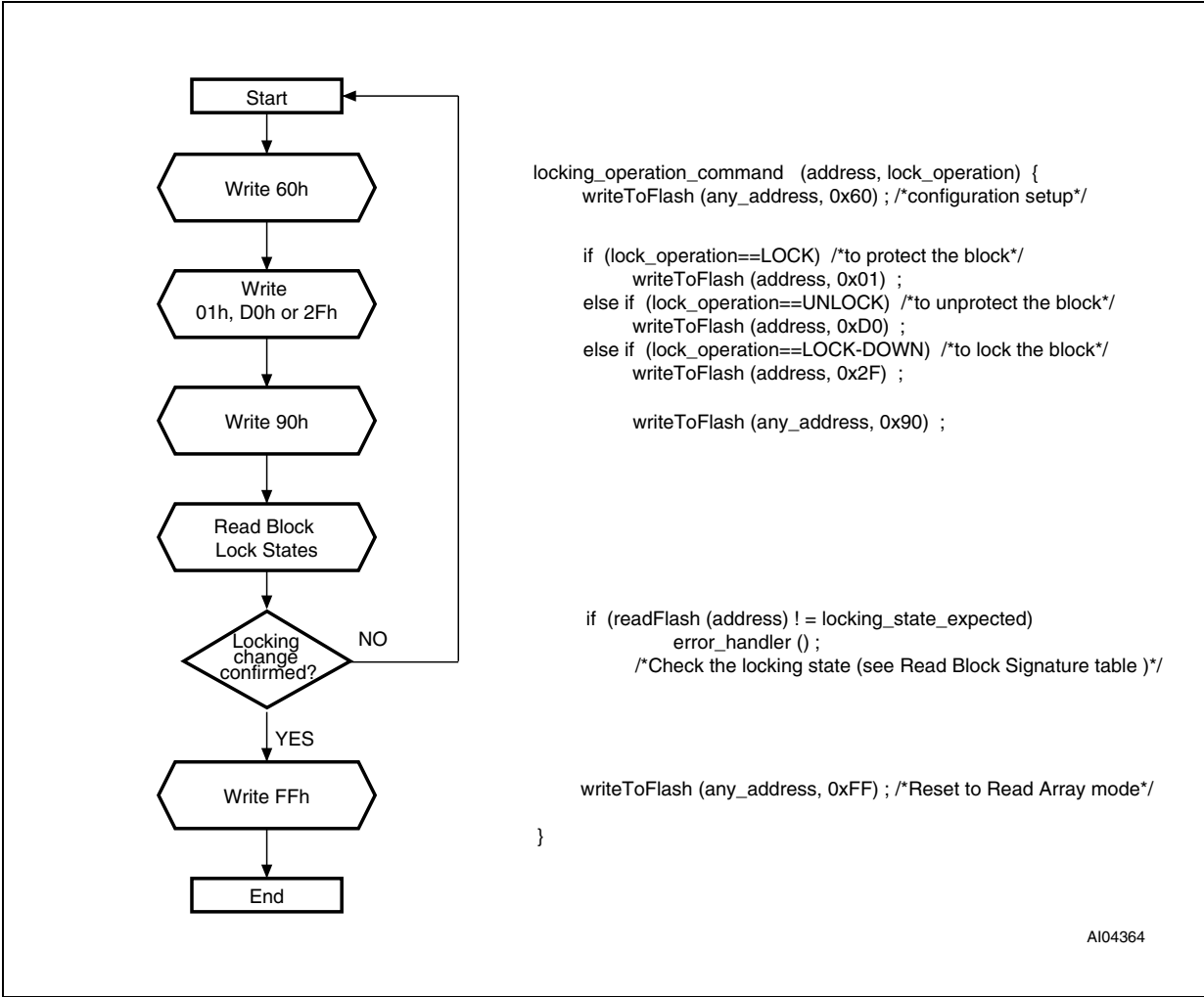
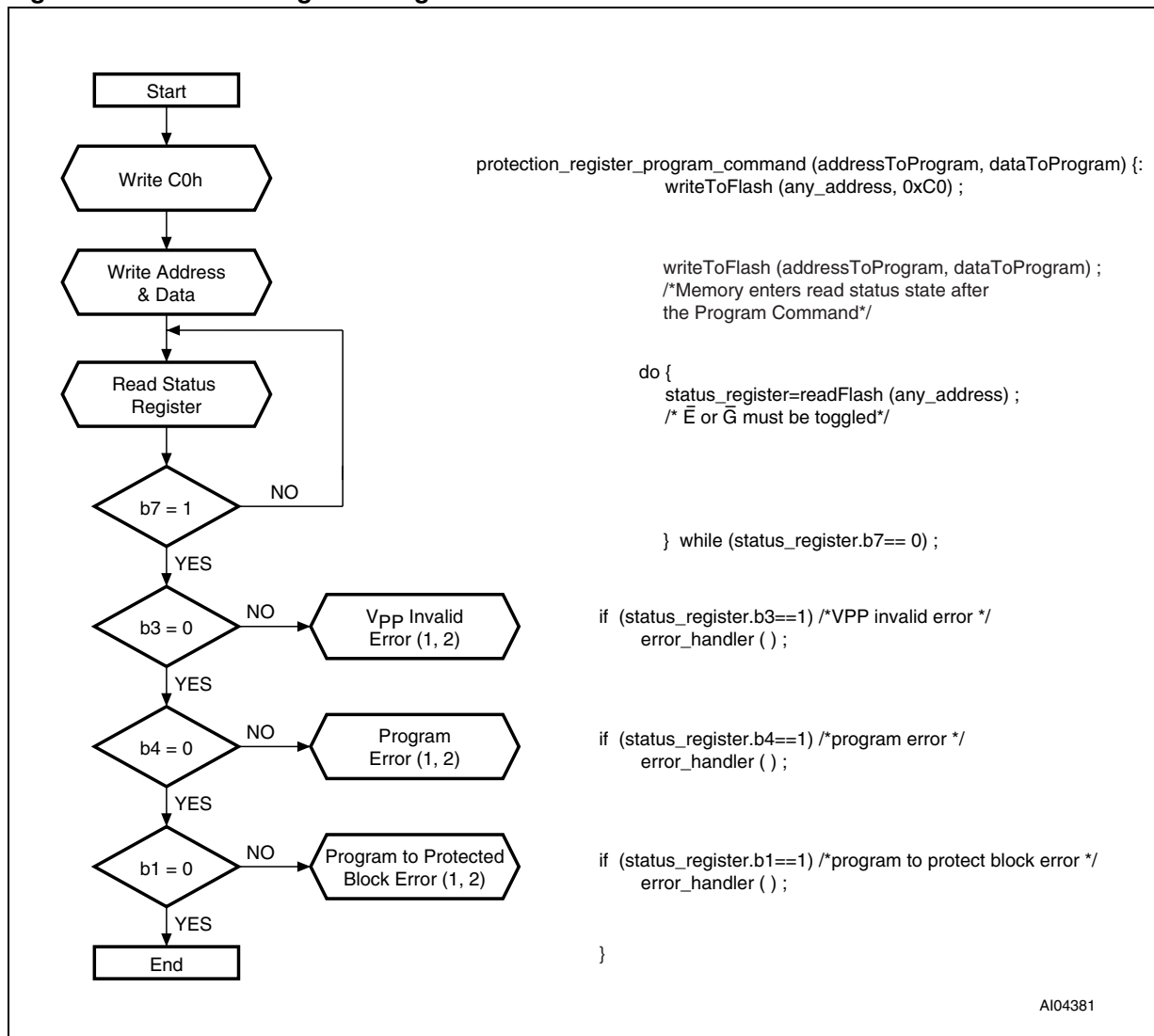

Figure 22. Locking Operations Flowchart and Pseudo Code



AI04364

Figure 23. Protection Register Program Flowchart and Pseudo Code



Note: 1. Status check of b1 (Protected Block), b3 (VPP Invalid) and b4 (Program Error) can be made after each program operation or after a sequence.  
 2. If an error is found, the Status Register must be cleared before further Program/Erase Controller operations.

## APPENDIX D. COMMAND INTERFACE AND PROGRAM/ERASE CONTROLLER STATE

Table 31. Write State Machine Current/Next, sheet 1 of 2.

Current State	SR bit 7	Data When Read	Command Input (and Next State)								
			Read Array (FFh)	Program Setup (10/40h)	Erase Setup (20h)	Erase Confirm (D0h)	Prog/Ers Suspend (B0h)	Prog/Ers Resume (D0h)	Read Status (70h)	Clear Status (50h)	
Read Array	"1"	Array	Read Array	Prog.Setup	Ers. Setup	Read Array			Read Sts.	Read Array	
Read Status	"1"	Status	Read Array	Program Setup	Erase Setup	Read Array			Read Status	Read Array	
Read Elect.Sg.	"1"	Electronic Signature	Read Array	Program Setup	Erase Setup	Read Array			Read Status	Read Array	
Read CFI Query	"1"	CFI	Read Array	Program Setup	Erase Setup	Read Array			Read Status	Read Array	
Lock Setup	"1"	Status	Lock Command Error			Lock (complete)	Lock Cmd Error	Lock (complete)	Lock Command Error		
Lock Cmd Error	"1"	Status	Read Array	Program Setup	Erase Setup	Read Array			Read Status	Read Array	
Lock (complete)	"1"	Status	Read Array	Program Setup	Erase Setup	Read Array			Read Status	Read Array	
Prot. Prog. Setup	"1"	Status	Protection Register Program								
Prot. Prog. (continue)	"0"	Status	Protection Register Program continue								
Prot. Prog. (complete)	"1"	Status	Read Array	Program Setup	Erase Setup	Read Array			Read Status	Read Array	
Prog. Setup	"1"	Status	Program								
Program (continue)	"0"	Status	Program (continue)				Prog. Sus Read Sts	Program (continue)			
Prog. Sus Status	"1"	Status	Prog. Sus Read Array	Program Suspend to Read Array		Program (continue)	Prog. Sus Read Array	Program (continue)	Prog. Sus Read Sts	Prog. Sus Read Array	
Prog. Sus Read Array	"1"	Array	Prog. Sus Read Array	Program Suspend to Read Array		Program (continue)	Prog. Sus Read Array	Program (continue)	Prog. Sus Read Sts	Prog. Sus Read Array	
Prog. Sus Read Elect.Sg.	"1"	Electronic Signature	Prog. Sus Read Array	Program Suspend to Read Array		Program (continue)	Prog. Sus Read Array	Program (continue)	Prog. Sus Read Sts	Prog. Sus Read Array	
Prog. Sus Read CFI	"1"	CFI	Prog. Sus Read Array	Program Suspend to Read Array		Program (continue)	Prog. Sus Read Array	Program (continue)	Prog. Sus Read Sts	Prog. Sus Read Array	
Program (complete)	"1"	Status	Read Array	Program Setup	Erase Setup	Read Array			Read Status	Read Array	
Erase Setup	"1"	Status	Erase Command Error			Erase (continue)	Erase CmdError	Erase (continue)	Erase Command Error		
Erase Cmd.Error	"1"	Status	Read Array	Program Setup	Erase Setup	Read Array			Read Status	Read Array	
Erase (continue)	"0"	Status	Erase (continue)				Erase Sus Read Sts	Erase (continue)			
Erase Sus Read Sts	"1"	Status	Erase Sus Read Array	Program Setup	Erase Sus Read Array	Erase (continue)	Erase Sus Read Array	Erase (continue)	Erase Sus Read Sts	Erase Sus Read Array	
Erase Sus Read Array	"1"	Array	Erase Sus Read Array	Program Setup	Erase Sus Read Array	Erase (continue)	Erase Sus Read Array	Erase (continue)	Erase Sus Read Sts	Erase Sus Read Array	
Erase Sus Read Elect.Sg.	"1"	Electronic Signature	Erase Sus Read Array	Program Setup	Erase Sus Read Array	Erase (continue)	Erase Sus Read Array	Erase (continue)	Erase Sus Read Sts	Erase Sus Read Array	
Erase Sus Read CFI	"1"	CFI	Erase Sus Read Array	Program Setup	Erase Sus Read Array	Erase (continue)	Erase Sus Read Array	Erase (continue)	Erase Sus Read Sts	Erase Sus Read Array	
Erase (complete)	"1"	Status	Read Array	Program Setup	Erase Setup	Read Array			Read Status	Read Array	

Note: Cmd = Command, Elect.Sg. = Electronic Signature, Ers = Erase, Prog. = Program, Prot = Protection, Sus = Suspend.

## M28W160ECT, M28W160ECB

**Table 32. Write State Machine Current/Next, sheet 2 of 2.**

Current State	Command Input (and Next State)						
	Read Elect.Sg. (90h)	Read CFI Query (98h)	Lock Setup (60h)	Prot. Prog. Setup (C0h)	Lock Confirm (01h)	Lock Down Confirm (2Fh)	Unlock Confirm (D0h)
Read Array	Read Elect.Sg.	Read CFI Query	Lock Setup	Prot. Prog. Setup	Read Array		
Read Status	Read Elect.Sg.	Read CFI Query	Lock Setup	Prot. Prog. Setup	Read Array		
Read Elect.Sg.	Read Elect.Sg.	Read CFI Query	Lock Setup	Prot. Prog. Setup	Read Array		
Read CFI Query	Read Elect.Sg.	Read CFI Query	Lock Setup	Prot. Prog. Setup	Read Array		
Lock Setup	Lock Command Error				Lock (complete)		
Lock Cmd Error	Read Elect.Sg.	Read CFI Query	Lock Setup	Prot. Prog. Setup	Read Array		
Lock (complete)	Read Elect.Sg.	Read CFI Query	Lock Setup	Prot. Prog. Setup	Read Array		
Prot. Prog. Setup	Protection Register Program						
Prot. Prog. (continue)	Protection Register Program (continue)						
Prot. Prog. (complete)	Read Elect.Sg.	Read CFI Query	Lock Setup	Prot. Prog. Setup	Read Array		
Prog. Setup	Program						
Program (continue)	Program (continue)						
Prog. Suspend Read Status	Prog. Suspend Read Elect.Sg.	Prog. Suspend Read CFI Query	Program Suspend Read Array			Program (continue)	
Prog. Suspend Read Array	Prog. Suspend Read Elect.Sg.	Prog. Suspend Read CFI Query	Program Suspend Read Array			Program (continue)	
Prog. Suspend Read Elect.Sg.	Prog. Suspend Read Elect.Sg.	Prog. Suspend Read CFI Query	Program Suspend Read Array			Program (continue)	
Prog. Suspend Read CFI	Prog. Suspend Read Elect.Sg.	Prog. Suspend Read CFI Query	Program Suspend Read Array			Program (continue)	
Program (complete)	Read Elect.Sg.	Read CFI Query	Lock Setup	Prot. Prog. Setup	Read Array		
Erase Setup	Erase Command Error					Erase (continue)	
Erase Cmd.Error	Read Elect.Sg.	Read CFI Query	Lock Setup	Prot. Prog. Setup	Read Array		
Erase (continue)	Erase (continue)						
Erase Suspend Read Status	Erase Suspend Read Elect.Sg.	Erase Suspend Read CFI Query	Lock Setup	Erase Suspend Read Array		Erase (continue)	
Erase Suspend Read Array	Erase Suspend Read Elect.Sg.	Erase Suspend Read CFI Query	Lock Setup	Erase Suspend Read Array		Erase (continue)	
Erase Suspend Read Elect.Sg.	Erase Suspend Read Elect.Sg.	Erase Suspend Read CFI Query	Lock Setup	Erase Suspend Read Array		Erase (continue)	
Erase Suspend Read CFI Query	Erase Suspend Read Elect.Sg.	Erase Suspend Read CFI Query	Lock Setup	Erase Suspend Read Array		Erase (continue)	
Erase (complete)	Read Elect.Sg.	Read CFI Query	Lock Setup	Prot. Prog. Setup	Read Array		

Note: Cmd = Command, Elect.Sg. = Electronic Signature, Prog. = Program, Prot = Protection.

## REVISION HISTORY

**Table 33. Document Revision History**

Date	Version	Revision Details
21-Nov-2002	1.0	First Issue
18-Feb-2004	2.0	S packing option added to <a href="#">Table 21., Ordering Information Scheme</a> and <a href="#">Table 22., Daisy Chain Ordering Scheme</a> . Document Status promoted from Target Specification to Preliminary Data.
1-July-2004	3.0	Datasheet status updated to "Full Datasheet". Lead-free package options added in <a href="#">FEATURES SUMMARY</a> , <a href="#">SIGNAL DESCRIPTIONS</a> , <a href="#">Table 11., Absolute Maximum Ratings</a> and <a href="#">PART NUMBERING</a> sections. Tape & Reel Packing options updated in <a href="#">Table 21., Ordering Information Scheme</a> and <a href="#">Table 22., Daisy Chain Ordering Scheme</a>
5-Aug-2004	4.0	<a href="#">Table 21., Ordering Information Scheme</a> and <a href="#">Table 22., Daisy Chain Ordering Scheme</a> updated.
16-Nov-2004	5.0	U packing option added in <a href="#">Table 21., Ordering Information Scheme</a> .
01-Dec-2005	6	ECOPACK text updated. Main Block Erase time and Parameter Block Erase time updated in <a href="#">Table 7., Program, Erase Times and Program/Erase Endurance Cycles. Note: 1. and 2.</a> added. <a href="#">Figure 13., TSOP48 - 48 lead Plastic Thin Small Outline, 12 x 20mm, Package Outline</a> and <a href="#">Table 19., TSOP48 - 48 lead Plastic Thin Small Outline, 12 x 20mm, Package Mechanical Data</a> updated.
26-Mar-2008	7	Applied Numonyx branding.

**Please Read Carefully:**

INFORMATION IN THIS DOCUMENT IS PROVIDED IN CONNECTION WITH NUMONYX™ PRODUCTS. NO LICENSE, EXPRESS OR IMPLIED, BY ESTOPPEL OR OTHERWISE, TO ANY INTELLECTUAL PROPERTY RIGHTS IS GRANTED BY THIS DOCUMENT. EXCEPT AS PROVIDED IN NUMONYX'S TERMS AND CONDITIONS OF SALE FOR SUCH PRODUCTS, NUMONYX ASSUMES NO LIABILITY WHATSOEVER, AND NUMONYX DISCLAIMS ANY EXPRESS OR IMPLIED WARRANTY, RELATING TO SALE AND/OR USE OF NUMONYX PRODUCTS INCLUDING LIABILITY OR WARRANTIES RELATING TO FITNESS FOR A PARTICULAR PURPOSE, MERCHANTABILITY, OR INFRINGEMENT OF ANY PATENT, COPYRIGHT OR OTHER INTELLECTUAL PROPERTY RIGHT.

Numonyx products are not intended for use in medical, life saving, life sustaining, critical control or safety systems, or in nuclear facility applications.

Numonyx may make changes to specifications and product descriptions at any time, without notice.

Numonyx, B.V. may have patents or pending patent applications, trademarks, copyrights, or other intellectual property rights that relate to the presented subject matter. The furnishing of documents and other materials and information does not provide any license, express or implied, by estoppel or otherwise, to any such patents, trademarks, copyrights, or other intellectual property rights.

Designers must not rely on the absence or characteristics of any features or instructions marked "reserved" or "undefined." Numonyx reserves these for future definition and shall have no responsibility whatsoever for conflicts or incompatibilities arising from future changes to them.

Contact your local Numonyx sales office or your distributor to obtain the latest specifications and before placing your product order.

Copies of documents which have an order number and are referenced in this document, or other Numonyx literature may be obtained by visiting Numonyx's website at <http://www.numonyx.com>.

Numonyx StrataFlash is a trademark or registered trademark of Numonyx or its subsidiaries in the United States and other countries.

\*Other names and brands may be claimed as the property of others.

Copyright © 11/5/7, Numonyx, B.V., All Rights Reserved.

## Looking for pricing, stock, or lifecycle information?

Click below to explore more details on WIN SOURCE:

- ⊖ [View M28W160ECT70ZB6E on WIN SOURCE](#)
- ⊖ [Micron Technology Inc. Information](#)

## Optimize Your Supply Chain with WIN SOURCE Solutions

- ✓ Global Sourcing Solution
- ✓ Obsolete Management
- ✓ Cost Control Management
- ✓ Shortage Management
- ✓ Alternative Solution
- ✓ Excess Inventory Management