

To our customers,

Old Company Name in Catalogs and Other Documents

On April 1st, 2010, NEC Electronics Corporation merged with Renesas Technology Corporation, and Renesas Electronics Corporation took over all the business of both companies. Therefore, although the old company name remains in this document, it is a valid Renesas Electronics document. We appreciate your understanding.

Renesas Electronics website: <http://www.renesas.com>

April 1st, 2010
Renesas Electronics Corporation

Issued by: Renesas Electronics Corporation (<http://www.renesas.com>)

Send any inquiries to <http://www.renesas.com/inquiry>.

Notice

1. All information included in this document is current as of the date this document is issued. Such information, however, is subject to change without any prior notice. Before purchasing or using any Renesas Electronics products listed herein, please confirm the latest product information with a Renesas Electronics sales office. Also, please pay regular and careful attention to additional and different information to be disclosed by Renesas Electronics such as that disclosed through our website.
2. Renesas Electronics does not assume any liability for infringement of patents, copyrights, or other intellectual property rights of third parties by or arising from the use of Renesas Electronics products or technical information described in this document. No license, express, implied or otherwise, is granted hereby under any patents, copyrights or other intellectual property rights of Renesas Electronics or others.
3. You should not alter, modify, copy, or otherwise misappropriate any Renesas Electronics product, whether in whole or in part.
4. Descriptions of circuits, software and other related information in this document are provided only to illustrate the operation of semiconductor products and application examples. You are fully responsible for the incorporation of these circuits, software, and information in the design of your equipment. Renesas Electronics assumes no responsibility for any losses incurred by you or third parties arising from the use of these circuits, software, or information.
5. When exporting the products or technology described in this document, you should comply with the applicable export control laws and regulations and follow the procedures required by such laws and regulations. You should not use Renesas Electronics products or the technology described in this document for any purpose relating to military applications or use by the military, including but not limited to the development of weapons of mass destruction. Renesas Electronics products and technology may not be used for or incorporated into any products or systems whose manufacture, use, or sale is prohibited under any applicable domestic or foreign laws or regulations.
6. Renesas Electronics has used reasonable care in preparing the information included in this document, but Renesas Electronics does not warrant that such information is error free. Renesas Electronics assumes no liability whatsoever for any damages incurred by you resulting from errors in or omissions from the information included herein.
7. Renesas Electronics products are classified according to the following three quality grades: “Standard”, “High Quality”, and “Specific”. The recommended applications for each Renesas Electronics product depends on the product’s quality grade, as indicated below. You must check the quality grade of each Renesas Electronics product before using it in a particular application. You may not use any Renesas Electronics product for any application categorized as “Specific” without the prior written consent of Renesas Electronics. Further, you may not use any Renesas Electronics product for any application for which it is not intended without the prior written consent of Renesas Electronics. Renesas Electronics shall not be in any way liable for any damages or losses incurred by you or third parties arising from the use of any Renesas Electronics product for an application categorized as “Specific” or for which the product is not intended where you have failed to obtain the prior written consent of Renesas Electronics. The quality grade of each Renesas Electronics product is “Standard” unless otherwise expressly specified in a Renesas Electronics data sheets or data books, etc.
 - “Standard”: Computers; office equipment; communications equipment; test and measurement equipment; audio and visual equipment; home electronic appliances; machine tools; personal electronic equipment; and industrial robots.
 - “High Quality”: Transportation equipment (automobiles, trains, ships, etc.); traffic control systems; anti-disaster systems; anti-crime systems; safety equipment; and medical equipment not specifically designed for life support.
 - “Specific”: Aircraft; aerospace equipment; submersible repeaters; nuclear reactor control systems; medical equipment or systems for life support (e.g. artificial life support devices or systems), surgical implantations, or healthcare intervention (e.g. excision, etc.), and any other applications or purposes that pose a direct threat to human life.
8. You should use the Renesas Electronics products described in this document within the range specified by Renesas Electronics, especially with respect to the maximum rating, operating supply voltage range, movement power voltage range, heat radiation characteristics, installation and other product characteristics. Renesas Electronics shall have no liability for malfunctions or damages arising out of the use of Renesas Electronics products beyond such specified ranges.
9. Although Renesas Electronics endeavors to improve the quality and reliability of its products, semiconductor products have specific characteristics such as the occurrence of failure at a certain rate and malfunctions under certain use conditions. Further, Renesas Electronics products are not subject to radiation resistance design. Please be sure to implement safety measures to guard them against the possibility of physical injury, and injury or damage caused by fire in the event of the failure of a Renesas Electronics product, such as safety design for hardware and software including but not limited to redundancy, fire control and malfunction prevention, appropriate treatment for aging degradation or any other appropriate measures. Because the evaluation of microcomputer software alone is very difficult, please evaluate the safety of the final products or system manufactured by you.
10. Please contact a Renesas Electronics sales office for details as to environmental matters such as the environmental compatibility of each Renesas Electronics product. Please use Renesas Electronics products in compliance with all applicable laws and regulations that regulate the inclusion or use of controlled substances, including without limitation, the EU RoHS Directive. Renesas Electronics assumes no liability for damages or losses occurring as a result of your noncompliance with applicable laws and regulations.
11. This document may not be reproduced or duplicated, in any form, in whole or in part, without prior written consent of Renesas Electronics.
12. Please contact a Renesas Electronics sales office if you have any questions regarding the information contained in this document or Renesas Electronics products, or if you have any other inquiries.

(Note 1) “Renesas Electronics” as used in this document means Renesas Electronics Corporation and also includes its majority-owned subsidiaries.

(Note 2) “Renesas Electronics product(s)” means any product developed or manufactured by or for Renesas Electronics.

1. Overview

The M16C/62P Group (M16C/62P, M16C/62PT) of single-chip microcomputers are built using the high performance silicon gate CMOS process using a M16C/60 Series CPU core and are packaged in a 80-pin, 100-pin and 128-pin plastic molded QFP. These single-chip microcomputers operate using sophisticated instructions featuring a high level of instruction efficiency. With 1M bytes of address space, they are capable of executing instructions at high speed. In addition, this microcomputer contains a multiplier and DMAC which combined with fast instruction processing capability, makes it suitable for control of various OA, communication, and industrial equipment which requires high-speed arithmetic/logic operations.

1.1 Applications

Audio, cameras, television, home appliance, office/communications/portable/industrial equipment, automobile, etc.

Specifications written in this manual are believed to be accurate, but are not guaranteed to be entirely free of error. Specifications in this manual may be changed for functional or performance improvements. Please make sure your manual is the latest edition.

1.2 Performance Outline

Table 1.1 to 1.3 list Performance Outline of M16C/62P Group (M16C/62P, M16C/62PT)(128-pin version).

Table 1.1 Performance Outline of M16C/62P Group (M16C/62P, M16C/62PT)(128-pin version)

	Item	Performance
		M16C/62P
CPU	Number of Basic Instructions	91 instructions
	Minimum Instruction Execution Time	41.7ns(f(BCLK)=24MHz, VCC1=3.3 to 5.5V) 100ns(f(BCLK)=10MHz, VCC1=2.7 to 5.5V)
	Operating Mode	Single-chip, memory expansion and microprocessor mode
	Address Space	1 Mbyte (Available to 4 Mbytes by memory space expansion function)
	Memory Capacity	See Table 1.4 to 1.5 Product List
Peripheral Function	Port	Input/Output : 113 pins, Input : 1 pin
	Multifunction Timer	Timer A : 16 bits x 5 channels, Timer B : 16 bits x 6 channels, Three phase motor control circuit
	Serial Interface	3 channels Clock synchronous, UART, I ² C bus ⁽¹⁾ , IEBus ⁽²⁾ 2 channels Clock synchronous
	A/D Converter	10-bit A/D converter: 1 circuit, 26 channels
	D/A Converter	8 bits x 2 channels
	DMAC	2 channels
	CRC Calculation Circuit	CCITT-CRC
	Watchdog Timer	15 bits x 1 channel (with prescaler)
	Interrupt	Internal: 29 sources, External: 8 sources, Software: 4 sources, Priority level: 7 levels
	Clock Generation Circuit	4 circuits Main clock generation circuit (*), Subclock generation circuit (*), On-chip oscillator, PLL synthesizer (*)Equipped with a built-in feedback resistor.
	Oscillation Stop Detection Function	Stop detection of main clock oscillation, re-oscillation detection function
	Voltage Detection Circuit	Available (option ⁽⁴⁾)
Electric Characteristics	Supply Voltage	VCC1=3.0 to 5.5 V, VCC2=2.7V to VCC1 (f(BCLK)=24MHz) VCC1=2.7 to 5.5 V, VCC2=2.7V to VCC1 (f(BCLK)=10MHz)
	Power Consumption	14 mA (VCC1=VCC2=5V, f(BCLK)=24MHz) 8 mA (VCC1=VCC2=3V, f(BCLK)=10MHz) 1.8μA (VCC1=VCC2=3V, f(XCIN)=32kHz, wait mode) 0.7μA (VCC1=VCC2=3V, stop mode)
Flash memory version	Program/Erase Supply Voltage	3.3±0.3 V or 5.0±0.5 V
	Program and Erase Endurance	100 times (all area) or 1,000 times (user ROM area without block A and block 1) / 10,000 times (block A, block 1) ⁽³⁾
Operating Ambient Temperature	-20 to 85°C, -40 to 85°C ⁽³⁾	
Package	128-pin plastic mold LQFP	

NOTES:

- I²C bus is a registered trademark of Koninklijke Philips Electronics N. V.
- IEBus is a registered trademark of NEC Electronics Corporation.
- See **Table 1.8 Product Code** for the program and erase endurance, and operating ambient temperature. In addition 1,000 times/10,000 times are under development as of Jul., 2005. Please inquire about a release schedule.
- All options are on request basis.

Table 1.2 Performance Outline of M16C/62P Group (M16C/62P, M16C/62PT)(100-pin version)

	Item	Performance	
		M16C/62P	M16C/62PT ⁽⁴⁾
CPU	Number of Basic Instructions	91 instructions	
	Minimum Instruction Execution Time	41.7ns(f(BCLK)=24MHz, VCC1=3.3 to 5.5V) 100ns(f(BCLK)=10MHz, VCC1=2.7 to 5.5V)	41.7ns(f(BCLK)=24MHz, VCC1=4.0 to 5.5V)
	Operating Mode	Single-chip, memory expansion and microprocessor mode	Single-chip
	Address Space	1 Mbyte (Available to 4 Mbytes by memory space expansion function)	1 Mbyte
	Memory Capacity	See Table 1.4 to 1.7 Product List	
Peripheral Function	Port	Input/Output : 87 pins, Input : 1 pin	
	Multifunction Timer	Timer A : 16 bits x 5 channels, Timer B : 16 bits x 6 channels, Three phase motor control circuit	
	Serial Interface	3 channels Clock synchronous, UART, I ² C bus ⁽¹⁾ , IEBus ⁽²⁾ 2 channels Clock synchronous	
	A/D Converter	10-bit A/D converter: 1 circuit, 26 channels	
	D/A Converter	8 bits x 2 channels	
	DMAC	2 channels	
	CRC Calculation Circuit	CCITT-CRC	
	Watchdog Timer	15 bits x 1 channel (with prescaler)	
	Interrupt	Internal: 29 sources, External: 8 sources, Software: 4 sources, Priority level: 7 levels	
	Clock Generation Circuit	4 circuits Main clock generation circuit (*), Subclock generation circuit (*), On-chip oscillator, PLL synthesizer (*)Equipped with a built-in feedback resistor.	
	Oscillation Stop Detection Function	Stop detection of main clock oscillation, re-oscillation detection function	
	Voltage Detection Circuit	Available (option ⁽⁵⁾)	Absent
Electric Characteristics	Supply Voltage	VCC1=3.0 to 5.5 V, VCC2=2.7V to VCC1 (f(BCLK)=24MHz) VCC1=2.7 to 5.5 V, VCC2=2.7V to VCC1 (f(BCLK)=10MHz)	VCC1=VCC2=4.0 to 5.5V (f(BCLK)=24MHz)
	Power Consumption	14 mA (VCC1=VCC2=5V, f(BCLK)=24MHz) 8 mA (VCC1=VCC2=3V, f(BCLK)=10MHz) 1.8μA (VCC1=VCC2=3V, f(XCIN)=32kHz, wait mode) 0.7μA (VCC1=VCC2=3V, stop mode)	14 mA (VCC1=VCC2=5V, f(BCLK)=24MHz) 2.0μA (VCC1=VCC2=5V, f(XCIN)=32kHz, wait mode) 0.8μA (VCC1=VCC2=5V, stop mode)
Flash memory version	Program/Erase Supply Voltage	3.3±0.3 V or 5.0±0.5 V	
	Program and Erase Endurance	100 times (all area) or 1,000 times (user ROM area without block A and block 1) / 10,000 times (block A, block 1) ⁽³⁾	
Operating Ambient Temperature	-20 to 85°C, -40 to 85°C ⁽³⁾		T version : -40 to 85°C V version : -40 to 125°C
Package	100-pin plastic mold QFP, LQFP		

NOTES:

- I²C bus is a registered trademark of Koninklijke Philips Electronics N. V.
- IEBus is a registered trademark of NEC Electronics Corporation.
- See **Table 1.8 and 1.9 Product Code** for the program and erase endurance, and operating ambient temperature.
In addition 1,000 times/10,000 times are under development as of Jul., 2005. Please inquire about a release schedule.
- Use the M16C/62PT on VCC1=VCC2
- All options are on request basis.

Table 1.3 Performance Outline of M16C/62P Group (M16C/62P, M16C/62PT)(80-pin version)

	Item	Performance	
		M16C/62P	M16C/62PT ⁽⁴⁾
CPU	Number of Basic Instructions	91 instructions	
	Minimum Instruction Execution Time	41.7ns(f(BCLK)=24MHz, VCC1=3.3 to 5.5V) 100ns(f(BCLK)=10MHz, VCC1=2.7 to 5.5V)	41.7ns(f(BCLK)=24MHz, VCC1=4.0 to 5.5V)
	Operating Mode	Single-chip mode	
	Address Space	1 Mbyte	
	Memory Capacity	See Table 1.4 to 1.7 Product List	
Peripheral Function	Port	Input/Output : 70 pins, Input : 1 pin	
	Multifunction Timer	Timer A : 16 bits x 5 channels (Timer A1 and A2 are internal timer), Timer B : 16 bits x 6 channels (Timer B1 is internal timer)	
	Serial Interface	2 channels Clock synchronous, UART, I ² C bus ⁽¹⁾ , IEBus ⁽²⁾ 1 channel Clock synchronous, I ² C bus ⁽¹⁾ , IEBus ⁽²⁾ 2 channels Clock synchronous (1 channel is only transmission)	
	A/D Converter	10-bit A/D converter: 1 circuit, 26 channels	
	D/A Converter	8 bits x 2 channels	
	DMAC	2 channels	
	CRC Calculation Circuit	CCITT-CRC	
	Watchdog Timer	15 bits x 1 channel (with prescaler)	
	Interrupt	Internal: 29 sources, External: 5 sources, Software: 4 sources, Priority level: 7 levels	
	Clock Generation Circuit	4 circuits Main clock generation circuit (*), Subclock generation circuit (*), On-chip oscillator, PLL synthesizer (*)Equipped with a built-in feedback resistor.	
	Oscillation Stop Detection Function	Stop detection of main clock oscillation, re-oscillation detection function	
	Voltage Detection Circuit	Available (option ⁽⁴⁾)	Absent
	Electric Characteristics	Supply Voltage	VCC1=3.0 to 5.5 V, (f(BCLK)=24MHz) VCC1=2.7 to 5.5 V, (f(BCLK)=10MHz)
Power Consumption		14 mA (VCC1=5V, f(BCLK)=24MHz) 8 mA (VCC1=3V, f(BCLK)=10MHz) 1.8μA (VCC1=3V, f(XCIN)=32kHz, wait mode) 0.7μA (VCC1=3V, stop mode)	14 mA (VCC1=5V, f(BCLK)=24MHz) 2.0μA (VCC1=5V, f(XCIN)=32kHz, wait mode) 0.8μA (VCC1=5V, stop mode)
Flash memory version	Program/Erase Supply Voltage	3.3 ± 0.3V or 5.0 ± 0.5V	5.0 ± 0.5V
	Program and Erase Endurance	100 times (all area) or 1,000 times (user ROM area without block A and block 1) / 10,000 times (block A, block 1) ⁽³⁾	
Operating Ambient Temperature	-20 to 85°C, -40 to 85°C ⁽³⁾	T version : -40 to 85°C V version : -40 to 125°C	
Package	80-pin plastic mold QFP		

NOTES:

- I²C bus is a registered trademark of Koninklijke Philips Electronics N. V.
- IEBus is a registered trademark of NEC Electronics Corporation.
- See **Table 1.8 and 1.9 Product Code** for the program and erase endurance, and operating ambient temperature.
In addition 1,000 times/10,000 times are under development as of Jul., 2005. Please inquire about a release schedule.
- All options are on request basis.

1.3 Block Diagram

Figure 1.1 is a M16C/62P Group (M16C/62P, M16C/62PT) 128-pin and 100-pin version Block Diagram, Figure 1.2 is a M16C/62P Group (M16C/62P, M16C/62PT) 80-pin version Block Diagram.

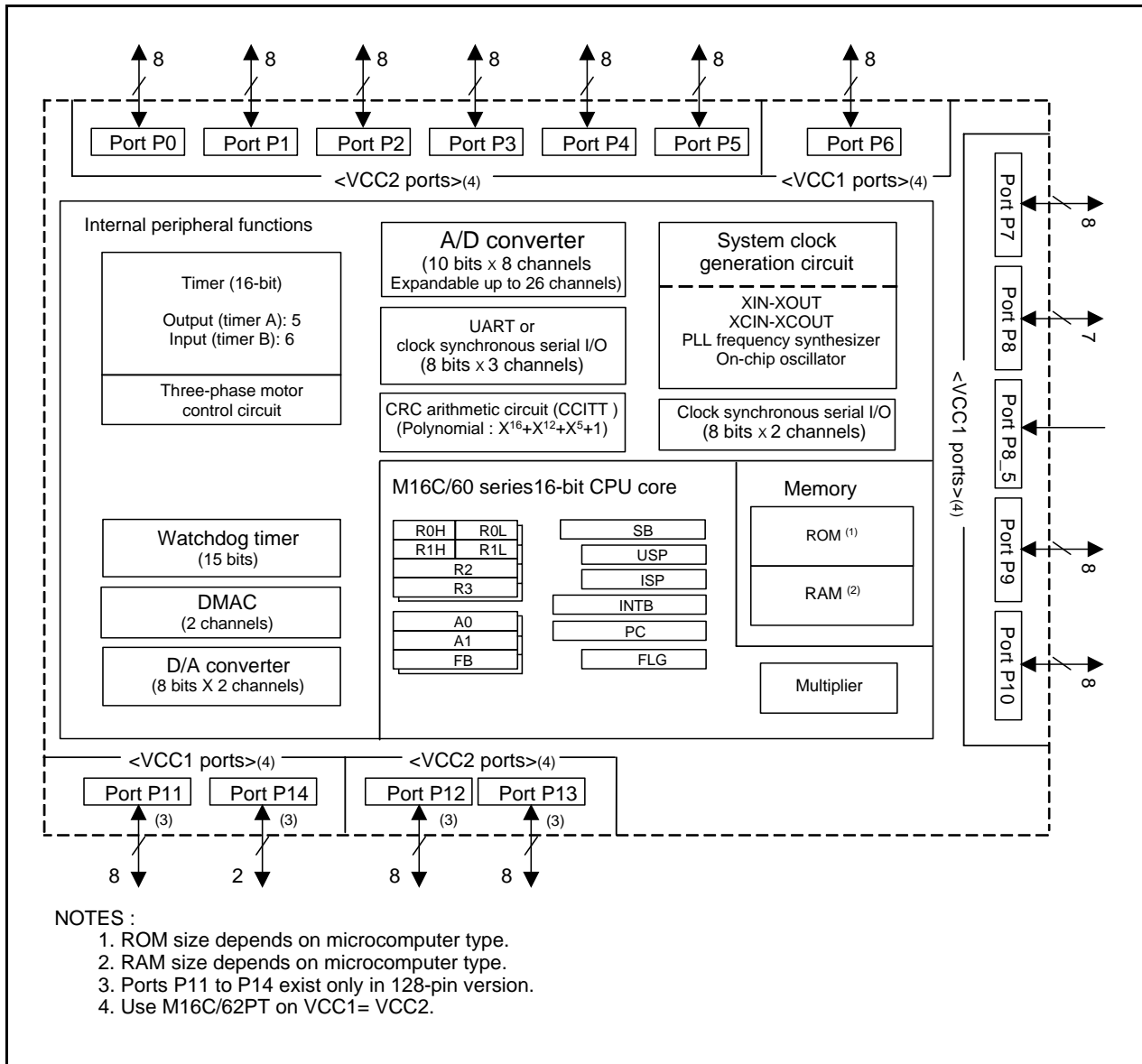


Figure 1.1 M16C/62P Group (M16C/62P, M16C/62PT) 128-pin and 100-pin version Block Diagram

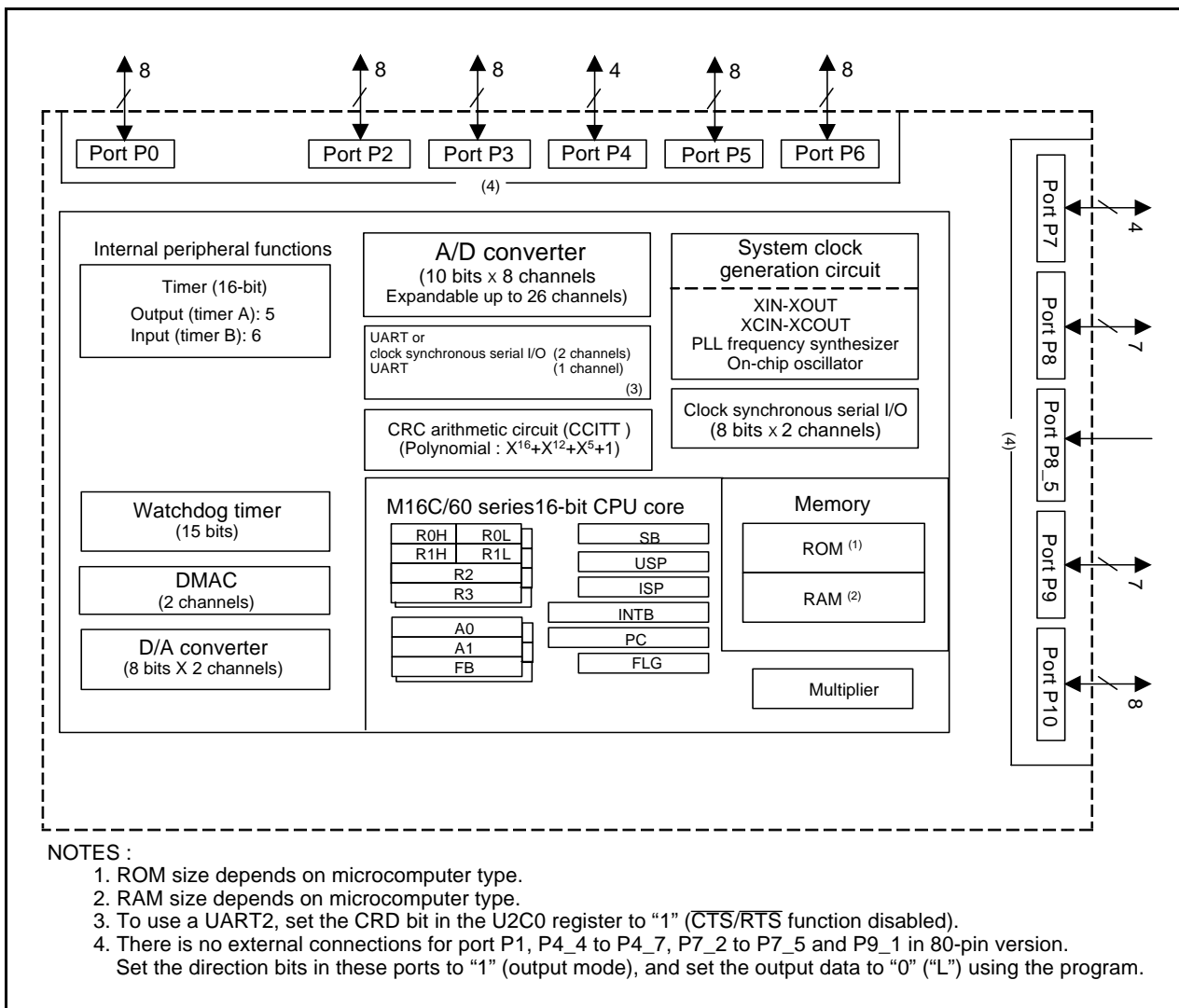


Figure 1.2 M16C/62P Group (M16C/62P, M16C/62PT) 80-pin version Block Diagram

1.4 Product List

Table 1.4 to 1.7 list the product list, Figure 1.3 shows the Type No., Memory Size, and Package, Table 1.8 lists the Product Code of Flash Memory version and ROMless version for M16C/62P, and Table 1.9 lists the Product Code of Flash Memory version for M16C/62PT. Figure 1.4 shows the Marking Diagram of Flash Memory version and ROM-less version for M16C/62P (Top View), and Figure 1.5 shows the Marking Diagram of Flash Memory version for M16C/62PT (Top View) at the time of ROM order.

Table 1.4 Product List (1) (M16C/62P)

As of Dec. 2005

Type No.	ROM Capacity	RAM Capacity	Package Type ⁽¹⁾	Remarks
M30622M6P-XXXFP	48 Kbytes	4 Kbytes	PRQP0100JB-A	Mask ROM version
M30622M6P-XXXGP			PLQP0100KB-A	
M30622M8P-XXXFP	64 Kbytes	4 Kbytes	PRQP0100JB-A	
M30622M8P-XXXGP			PLQP0100KB-A	
M30623M8P-XXXGP			PRQP0080JA-A	
M30622MAP-XXXFP	96 Kbytes	5 Kbytes	PRQP0100JB-A	
M30622MAP-XXXGP			PLQP0100KB-A	
M30623MAP-XXXGP			PRQP0080JA-A	
M30620MCP-XXXFP	128 Kbytes	10 Kbytes	PRQP0100JB-A	
M30620MCP-XXXGP			PLQP0100KB-A	
M30621MCP-XXXGP			PRQP0080JA-A	
M30622MEP-XXXFP	192 Kbytes	12 Kbytes	PRQP0100JB-A	
M30622MEP-XXXGP			PLQP0100KB-A	
M30623MEP-XXXGP			PLQP0128KB-A	
M30622MGP-XXXFP	256 Kbytes	12 Kbytes	PRQP0100JB-A	
M30622MGP-XXXGP			PLQP0100KB-A	
M30623MGP-XXXGP			PLQP0128KB-A	
M30624MGP-XXXFP		20 Kbytes	PRQP0100JB-A	
M30624MGP-XXXGP			PLQP0100KB-A	
M30625MGP-XXXGP			PLQP0128KB-A	
M30622MWP-XXXFP	320 Kbytes	16 Kbytes	PRQP0100JB-A	
M30622MWP-XXXGP			PLQP0100KB-A	
M30623MWP-XXXGP			PLQP0128KB-A	
M30624MWP-XXXFP		24 Kbytes	PRQP0100JB-A	
M30624MWP-XXXGP			PLQP0100KB-A	
M30625MWP-XXXGP			PLQP0128KB-A	
M30626MWP-XXXFP		31 Kbytes	PRQP0100JB-A	
M30626MWP-XXXGP			PLQP0100KB-A	
M30627MWP-XXXGP			PLQP0128KB-A	

(D): Under development

NOTES:

- The old package type numbers of each package type are as follows.
 PLQP0128KB-A : 128P6Q-A,
 PRQP0100JB-A : 100P6S-A,
 PLQP0100KB-A : 100P6Q-A,
 PRQP0080JA-A : 80P6S-A

Table 1.5 Product List (2) (M16C/62P)

As of Dec. 2005

Type No.	ROM Capacity	RAM Capacity	Package Type (1)	Remarks	
M30622MHP-XXXFP	384 Kbytes	16 Kbytes	PRQP0100JB-A	Mask ROM version	
M30622MHP-XXXGP			PLQP0100KB-A		
M30623MHP-XXXGP			PLQP0128KB-A		
M30624MHP-XXXFP		24 Kbytes	PRQP0100JB-A		
M30624MHP-XXXGP			PLQP0100KB-A		
M30625MHP-XXXGP			PLQP0128KB-A		
M30626MHP-XXXFP		31 Kbytes	PRQP0100JB-A		
M30626MHP-XXXGP			PLQP0100KB-A		
M30627MHP-XXXGP			PLQP0128KB-A		
M30626MJP-XXXFP (D)	512 Kbytes	31 Kbytes	PRQP0100JB-A		
M30626MJP-XXXGP (D)			PLQP0100KB-A		
M30627MJP-XXXGP (D)			PLQP0128KB-A		
M30622F8PFP	64K+4 Kbytes	4 Kbytes	PRQP0100JB-A	Flash memory version (2)	
M30622F8PGP			PLQP0100KB-A		
M30623F8PGP			PRQP0080JA-A		
M30620FCPFP	128K+4 Kbytes	10 Kbytes	PRQP0100JB-A		
M30620FCPGP			PLQP0100KB-A		
M30621FCPGP			PRQP0080JA-A		
M3062LFGPFP(3) (D)	256K+4 Kbytes	20 Kbytes	PRQP0100JB-A		
M3062LFGPGP(3) (D)			PLQP0100KB-A		
M30625FGPGP			PLQP0128KB-A		
M30626FHPFP	384K+4 Kbytes	31 Kbytes	PRQP0100JB-A		
M30626FHPGP			PLQP0100KB-A		
M30627FHPGP			PLQP0128KB-A		
M30626FJPFP	512K+4 Kbytes	31 Kbytes	PRQP0100JB-A		
M30626FJPGP			PLQP0100KB-A		
M30627FJPGP			PLQP0128KB-A		
M30622SPFP	-	4 Kbytes	PRQP0100JB-A	ROM-less version	
M30622SPGP			PLQP0100KB-A		
M30620SPFP		10 Kbytes	PRQP0100JB-A		
M30620SPGP			PLQP0100KB-A		
M30624SPFP (D)	-	20 Kbytes	PRQP0100JB-A		
M30624SPGP (D)			PLQP0100KB-A		
M30626SPFP (D)	-	31 Kbytes	PRQP0100JB-A		
M30626SPGP (D)			PLQP0100KB-A		

(D): Under development

NOTES:

- The old package type numbers of each package type are as follows.
 PLQP0128KB-A : 128P6Q-A,
 PRQP0100JB-A : 100P6S-A,
 PLQP0100KB-A : 100P6Q-A,
 PRQP0080JA-A : 80P6S-A
- In the flash memory version, there is 4K bytes area (block A).
- Please use M3062LFGPFP and M3062LFGPGP for your new system instead of M30624FGPFP and M30624FGPGP. The M16C/62P Group (M16C/62P, M16C/62PT) hardware manual is still good for M30624FGPFP and M30624FGPGP.

M30624FGPFP	256K+4 Kbytes	20 Kbytes	PRQP0100JB-A	Flash memory version
M30624FGPGP			PLQP0100KB-A	

Table 1.6 Product List (3) (T version (M16C/62PT)) As of Dec. 2005

Type No.	ROM Capacity	RAM Capacity	Package Type (1)	Remarks		
M3062CM6T-XXXFP (D)	48 Kbytes	4 Kbytes	PRQP0100JB-A	Mask ROM version	T Version (High reliability 85°C version)	
M3062CM6T-XXXGP (D)			PLQP0100KB-A			
M3062EM6T-XXXGP (P)			PRQP0080JA-A			
M3062CM8T-XXXFP (D)	64 Kbytes	4 Kbytes	PRQP0100JB-A			
M3062CM8T-XXXGP (D)			PLQP0100KB-A			
M3062EM8T-XXXGP (P)			PRQP0080JA-A			
M3062CMAT-XXXFP (D)	96 Kbytes	5 Kbytes	PRQP0100JB-A			
M3062CMAT-XXXGP (D)			PLQP0100KB-A			
M3062EMAT-XXXGP (P)			PRQP0080JA-A			
M3062AMCT-XXXFP (D)	128 Kbytes	10 Kbytes	PRQP0100JB-A			
M3062AMCT-XXXGP (D)			PLQP0100KB-A			
M3062BMCT-XXXGP (P)			PRQP0080JA-A			
M3062CF8TFP (D)	64 K+4 Kbytes	4 Kbytes	PRQP0100JB-A			Flash memory version (2)
M3062CF8TGP			PLQP0100KB-A			
M3062AFCTFP (D)	128K+4 Kbytes	10 Kbytes	PRQP0100JB-A			
M3062AFCTGP (D)			PLQP0100KB-A			
M3062BFCTGP (P)			PRQP0080JA-A			
M3062JFHTFP (D)	384K+4 Kbytes	31 Kbytes	PRQP0100JB-A			
M3062JFHTGP (D)			PLQP0100KB-A			

(D): Under development

(P): Under planning

NOTES:

- The old package type numbers of each package type are as follows.
PRQP0100JB-A : 100P6S-A,
PLQP0100KB-A : 100P6Q-A,
PRQP0080JA-A : 80P6S-A
- In the flash memory version, there is 4K bytes area (block A).

Table 1.7 Product List (4) (V version (M16C/62PT)) As of Dec. 2005

Type No.	ROM Capacity	RAM Capacity	Package Type ⁽¹⁾	Remarks		
M3062CM6V-XXXFP (P)	48 Kbytes	4 Kbytes	PRQP0100JB-A	Mask ROM version	V Version (High reliability 125°C version)	
M3062CM6V-XXXGP (P)			PLQP0100KB-A			
M3062EM6V-XXXGP (P)			PRQP0080JA-A			
M3062CM8V-XXXFP (P)	64 Kbytes	4 Kbytes	PRQP0100JB-A			
M3062CM8V-XXXGP (P)			PLQP0100KB-A			
M3062EM8V-XXXGP (P)			PRQP0080JA-A			
M3062CMAV-XXXFP (P)	96 Kbytes	5 Kbytes	PRQP0100JB-A			
M3062CMAV-XXXGP (P)			PLQP0100KB-A			
M3062EMAV-XXXGP (P)			PRQP0080JA-A			
M3062AMCV-XXXFP (D)	128 Kbytes	10 Kbytes	PRQP0100JB-A			Flash memory version ⁽²⁾
M3062AMCV-XXXGP (D)			PLQP0100KB-A			
M3062BMCV-XXXGP (P)			PRQP0080JA-A			
M3062AFCVFP (D)	128K+4 Kbytes	10 Kbytes	PRQP0100JB-A			
M3062AFCVGP (D)			PLQP0100KB-A			
M3062BFCVGP (P)			PRQP0080JA-A			
M3062JFHVFP (P)	384K+4 Kbytes	31 Kbytes	PRQP0100JB-A			
M3062JFHVGP (P)			PLQP0100KB-A			

(D): Under development

(P): Under planning

NOTES:

- The old package type numbers of each package type are as follows.
 PLQP0128KB-A : 128P6Q-A,
 PRQP0100JB-A : 100P6S-A,
 PLQP0100KB-A : 100P6Q-A,
 PRQP0080JA-A : 80P6S-A
- In the flash memory version, there is 4K bytes area (block A).

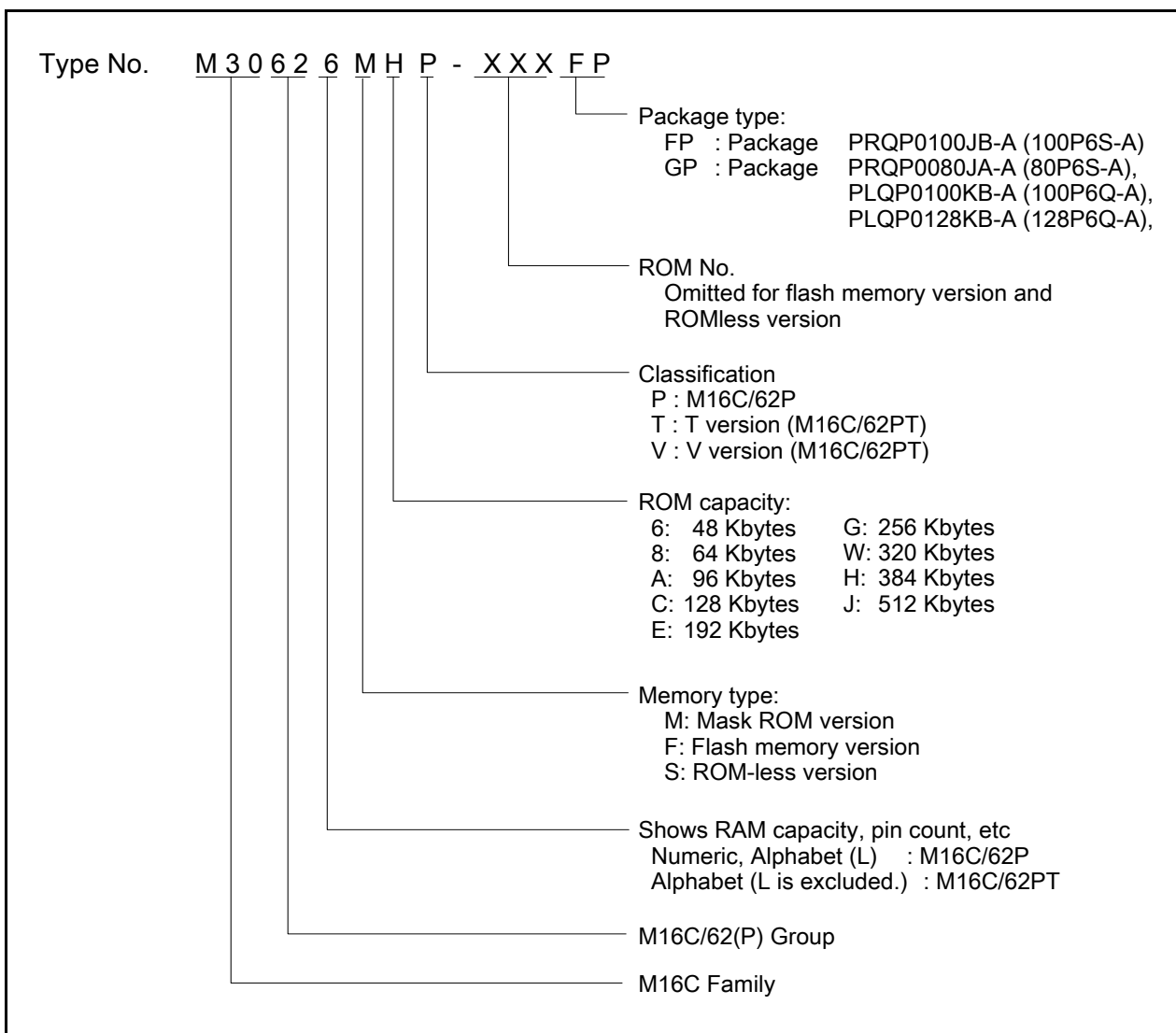


Figure 1.3 Type No., Memory Size, and Package

Table 1.8 Product Code of Flash Memory version and ROMless version for M16C/62P

	Product Code	Package	Internal ROM (User ROM Area Without Block A, Block 1)		Internal ROM (Block A, Block 1)		Operating Ambient Temperature
			Program and Erase Endurance	Temperature Range	Program and Erase Endurance	Temperature Range	
Flash memory Version	D3	Lead-included	100	0°C to 60°C	100	0°C to 60°C	-40°C to 85°C
	D5						-20°C to 85°C
	D7		1,000		10,000	-40°C to 85°C	
	D9					-20°C to 85°C	
	U3	Lead-free	100		100	0°C to 60°C	-40°C to 85°C
	U5						-20°C to 85°C
	U7		1,000		10,000	-40°C to 85°C	-40°C to 85°C
	U9						-20°C to 85°C
ROM-less version	D3	Lead-included	-	-	-	-	-40°C to 85°C
	D5		-	-	-	-	-20°C to 85°C
	U3	Lead-free	-	-	-	-	-40°C to 85°C
	U5		-	-	-	-	-20°C to 85°C



Figure 1.4 Marking Diagram of Flash Memory version and ROM-less version for M16C/62P (Top View)

Table 1.9 Product Code of Flash Memory version for M16C/62PT

	Product Code	Package	Internal ROM (User ROM Area Without Block A, Block 1)		Internal ROM (Block A, Block 1)		Operating Ambient Temperature	
			Program and Erase Endurance	Temperature Range	Program and Erase Endurance	Temperature Range		
Flash memory Version	T Version	B	Lead- included	100	0°C to 60°C	100	0°C to 60°C	-40°C to 85°C
	V Version							-40°C to 125°C
	T Version	B7	Lead-free	1,000	10,000	-40°C to 85°C	-40°C to 125°C	-40°C to 85°C
	V Version							-40°C to 125°C
	T Version	U	Lead-free	100	100	0°C to 60°C	-40°C to 85°C	-40°C to 85°C
	V Version							-40°C to 125°C
	T Version	U7	Lead-free	1,000	10,000	-40°C to 85°C	-40°C to 85°C	-40°C to 85°C
	V Version							-40°C to 125°C

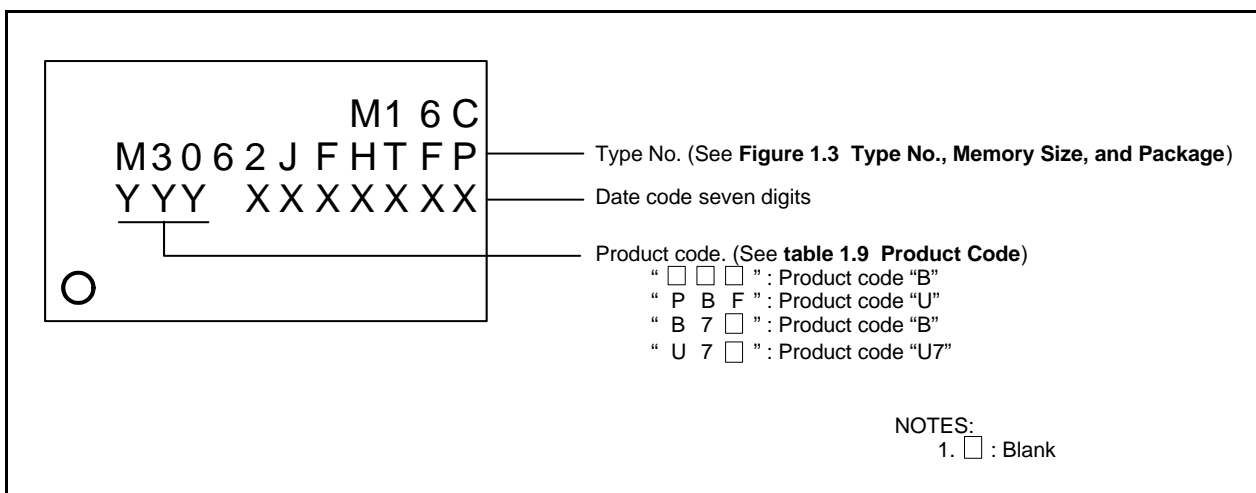


Figure 1.5 Marking Diagram of Flash Memory version for M16C/62PT (Top View)

1.5 Pin Configuration

Figures 1.6 to 1.9 show the Pin Configuration (Top View).

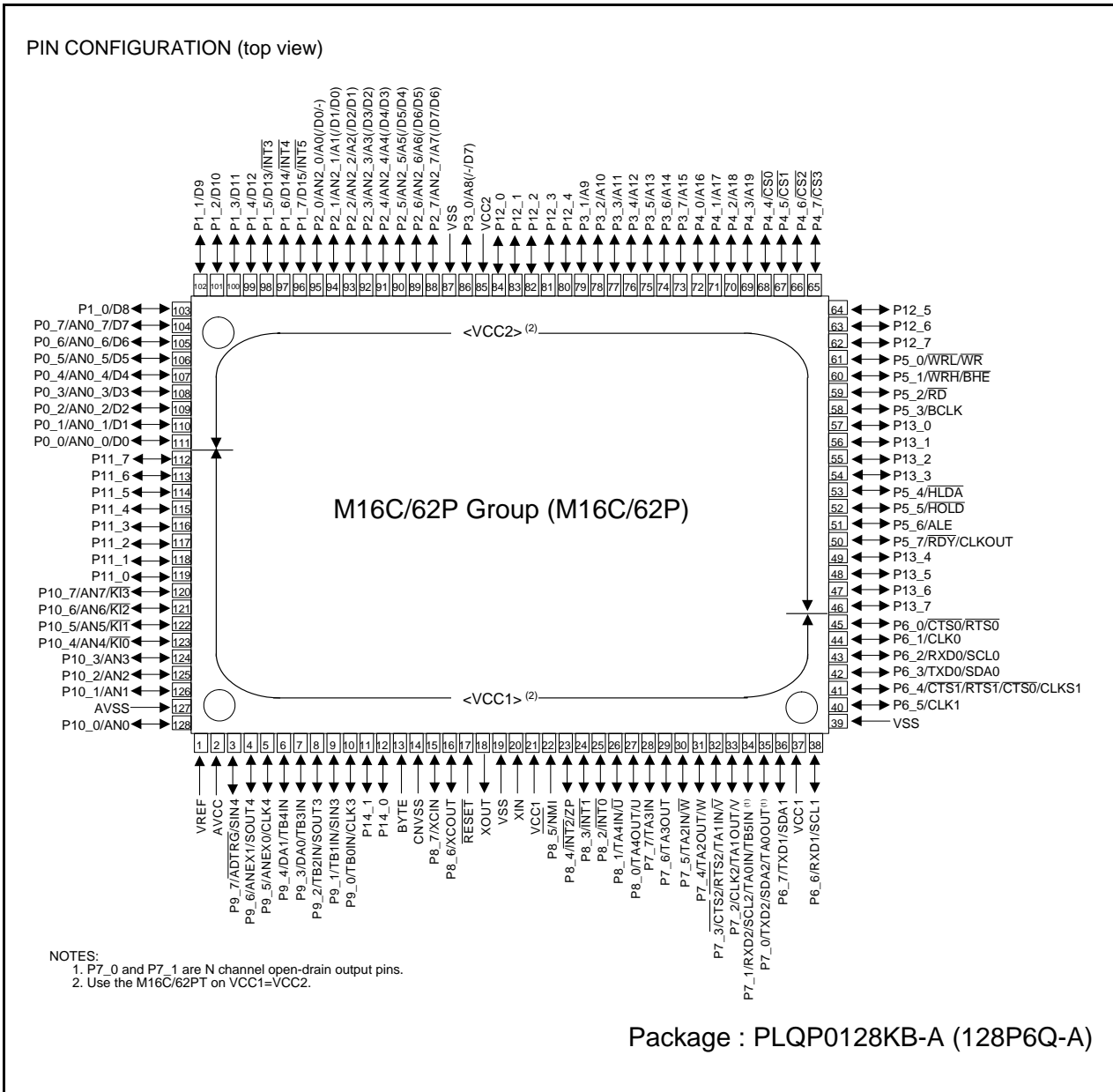


Figure 1.6 Pin Configuration (Top View)

Table 1.10 Pin Characteristics for 128-Pin Package (1)

Pin No.	Control Pin	Port	Interrupt Pin	Timer Pin	UART Pin	Analog Pin	Bus Control Pin
1	VREF						
2	AVCC						
3		P9_7			SIN4	ADTRG	
4		P9_6			SOUT4	ANEX1	
5		P9_5			CLK4	ANEX0	
6		P9_4		TB4IN		DA1	
7		P9_3		TB3IN		DA0	
8		P9_2		TB2IN	SOUT3		
9		P9_1		TB1IN	SIN3		
10		P9_0		TB0IN	CLK3		
11		P14_1					
12		P14_0					
13	BYTE						
14	CNVSS						
15	XCIN	P8_7					
16	XCOU	P8_6					
17	RESET						
18	XOUT						
19	VSS						
20	XIN						
21	VCC1						
22		P8_5	NMI				
23		P8_4	INT2	ZP			
24		P8_3	INT1				
25		P8_2	INT0				
26		P8_1		TA4IN/U			
27		P8_0		TA4OUT/U			
28		P7_7		TA3IN			
29		P7_6		TA3OUT			
30		P7_5		TA2IN/W			
31		P7_4		TA2OUT/W			
32		P7_3		TA1IN/V	CTS2/RTS2		
33		P7_2		TA1OUT/V	CLK2		
34		P7_1		TA0IN/TB5IN	RXD2/SCL2		
35		P7_0		TA0OUT	TXD2/SDA2		
36		P6_7			TXD1/SDA1		
37	VCC1						
38		P6_6			RXD1/SCL1		
39	VSS						
40		P6_5			CLK1		
41		P6_4			CTS1/RTS1/CTS0/CLKS1		
42		P6_3			TXD0/SDA0		
43		P6_2			RXD0/SCL0		
44		P6_1			CLK0		
45		P6_0			CTS0/RTS0		
46		P13_7					
47		P13_6					
48		P13_5					
49		P13_4					
50		P5_7					RDY/CLKOUT

Table 1.11 Pin Characteristics for 128-Pin Package (2)

Pin No.	Control Pin	Port	Interrupt Pin	Timer Pin	UART Pin	Analog Pin	Bus Control Pin
51		P5_6					ALE
52		P5_5					$\overline{\text{HOLD}}$
53		P5_4					$\overline{\text{HLDA}}$
54		P13_3					
55		P13_2					
56		P13_1					
57		P13_0					
58		P5_3					BCLK
59		P5_2					$\overline{\text{RD}}$
60		P5_1					$\overline{\text{WRH/BHE}}$
61		P5_0					$\overline{\text{WRL/WR}}$
62		P12_7					
63		P12_6					
64		P12_5					
65		P4_7					$\overline{\text{CS3}}$
66		P4_6					$\overline{\text{CS2}}$
67		P4_5					$\overline{\text{CS1}}$
68		P4_4					$\overline{\text{CS0}}$
69		P4_3					A19
70		P4_2					A18
71		P4_1					A17
72		P4_0					A16
73		P3_7					A15
74		P3_6					A14
75		P3_5					A13
76		P3_4					A12
77		P3_3					A11
78		P3_2					A10
79		P3_1					A9
80		P12_4					
81		P12_3					
82		P12_2					
83		P12_1					
84		P12_0					
85	VCC2						
86		P3_0					A8(/-D7)
87	VSS						
88		P2_7				AN2_7	A7(/D7/D6)
89		P2_6				AN2_6	A6(/D6/D5)
90		P2_5				AN2_5	A5(/D5/D4)
91		P2_4				AN2_4	A4(/D4/D3)
92		P2_3				AN2_3	A3(/D3/D2)
93		P2_2				AN2_2	A2(/D2/D1)
94		P2_1				AN2_1	A1(/D1/D0)
95		P2_0				AN2_0	A0(/D0/-)
96		P1_7	$\overline{\text{INT5}}$				D15
97		P1_6	$\overline{\text{INT4}}$				D14
98		P1_5	$\overline{\text{INT3}}$				D13
99		P1_4					D12
100		P1_3					D11

Table 1.12 Pin Characteristics for 128-Pin Package (3)

Pin No.	Control Pin	Port	Interrupt Pin	Timer Pin	UART Pin	Analog Pin	Bus Control Pin
101		P1_2					D10
102		P1_1					D9
103		P1_0					D8
104		P0_7				AN0_7	D7
105		P0_6				AN0_6	D6
106		P0_5				AN0_5	D5
107		P0_4				AN0_4	D4
108		P0_3				AN0_3	D3
109		P0_2				AN0_2	D2
110		P0_1				AN0_1	D1
111		P0_0				AN0_0	D0
112		P11_7					
113		P11_6					
114		P11_5					
115		P11_4					
116		P11_3					
117		P11_2					
118		P11_1					
119		P11_0					
120		P10_7	$\overline{KI3}$			AN7	
121		P10_6	$\overline{KI2}$			AN6	
122		P10_5	$\overline{KI1}$			AN5	
123		P10_4	$\overline{KI0}$			AN4	
124		P10_3				AN3	
125		P10_2				AN2	
126		P10_1				AN1	
127	AVSS						
128		P10_0				AN0	

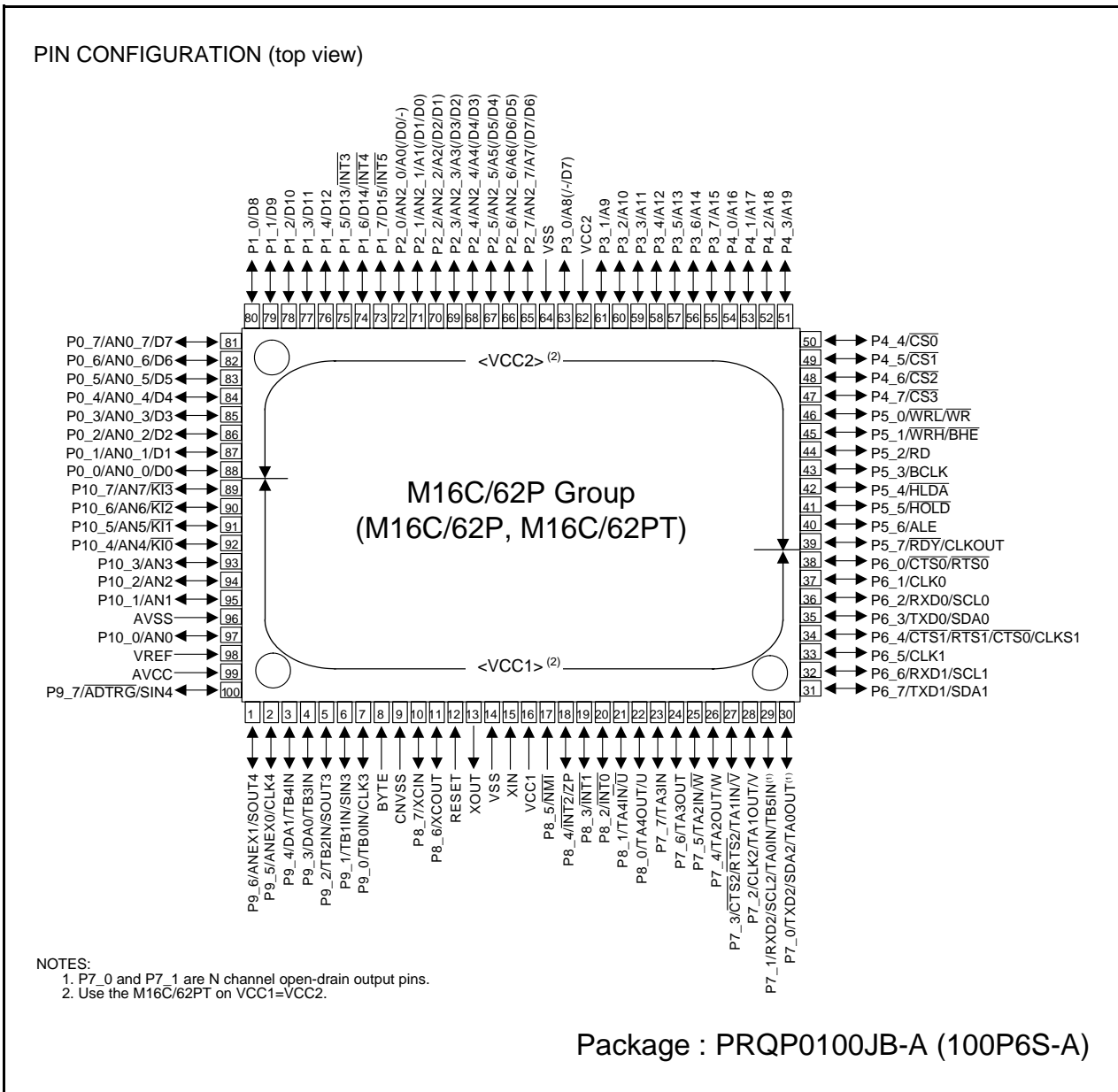


Figure 1.7 Pin Configuration (Top View)

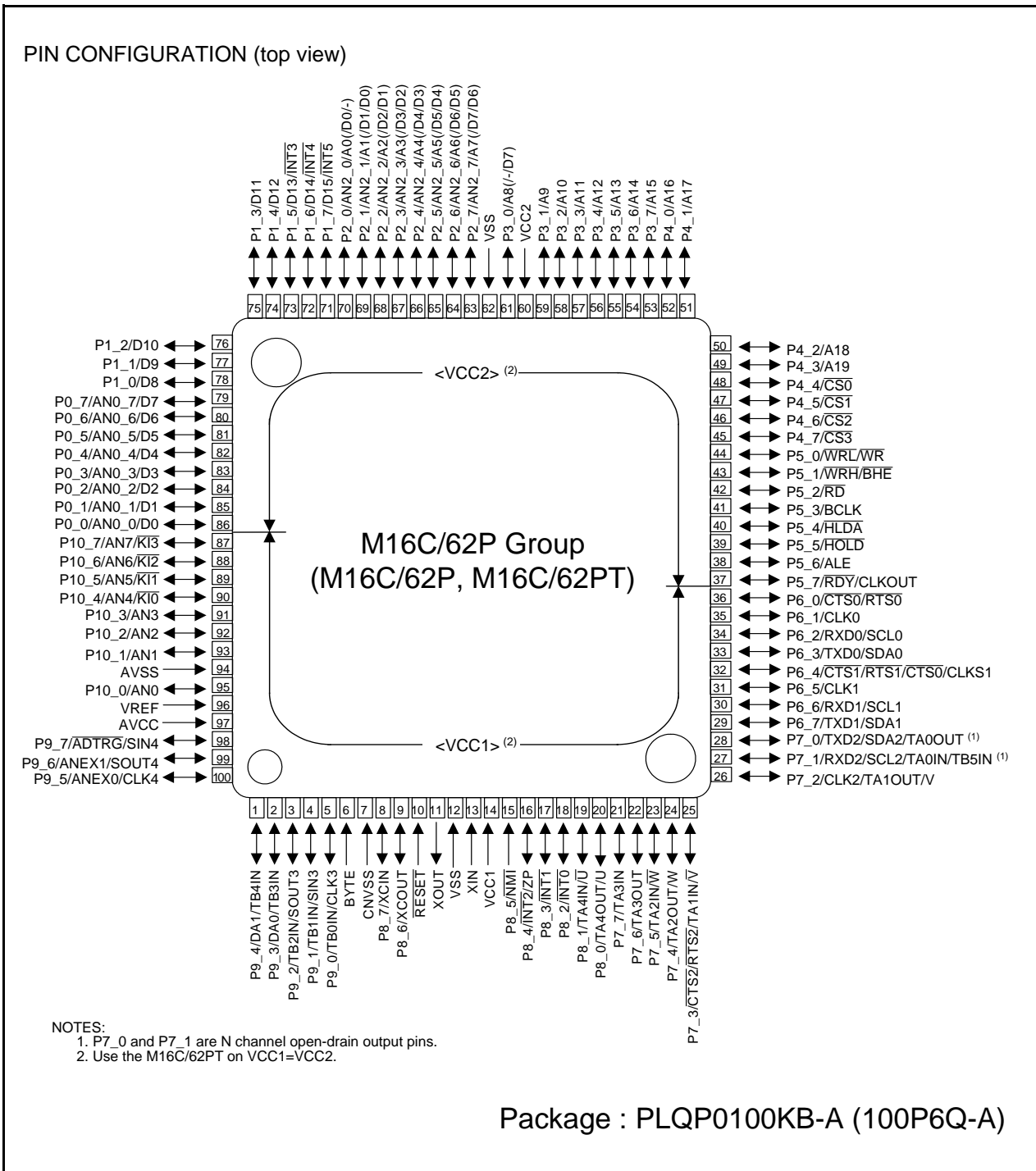


Figure 1.8 Pin Configuration (Top View)

Table 1.13 Pin Characteristics for 100-Pin Package (1)

Pin No.		Control Pin	Port	Interrupt Pin	Timer Pin	UART Pin	Analog Pin	Bus Control Pin
FP	GP							
1	99		P9_6			SOUT4	ANEX1	
2	100		P9_5			CLK4	ANEX0	
3	1		P9_4		TB4IN		DA1	
4	2		P9_3		TB3IN		DA0	
5	3		P9_2		TB2IN	SOUT3		
6	4		P9_1		TB1IN	SIN3		
7	5		P9_0		TB0IN	CLK3		
8	6	BYTE						
9	7	CNVSS						
10	8	XCIN	P8_7					
11	9	XCOUT	P8_6					
12	10	RESET						
13	11	XOUT						
14	12	VSS						
15	13	XIN						
16	14	VCC1						
17	15		P8_5	NMI				
18	16		P8_4	INT2	ZP			
19	17		P8_3	INT1				
20	18		P8_2	INT0				
21	19		P8_1		TA4IN/U			
22	20		P8_0		TA4OUT/U			
23	21		P7_7		TA3IN			
24	22		P7_6		TA3OUT			
25	23		P7_5		TA2IN/W			
26	24		P7_4		TA2OUT/W			
27	25		P7_3		TA1IN/V	CTS2/RTS2		
28	26		P7_2		TA1OUT/V	CLK2		
29	27		P7_1		TA0IN/TB5IN	RXD2/SCL2		
30	28		P7_0		TA0OUT	TXD2/SDA2		
31	29		P6_7			TXD1/SDA1		
32	30		P6_6			RXD1/SCL1		
33	31		P6_5			CLK1		
34	32		P6_4			CTS1/RTS1/CTS0/CLKS1		
35	33		P6_3			TXD0/SDA0		
36	34		P6_2			RXD0/SCL0		
37	35		P6_1			CLK0		
38	36		P6_0			CTS0/RTS0		
39	37		P5_7					RDY/CLKOUT
40	38		P5_6					ALE
41	39		P5_5					HOLD
42	40		P5_4					HLAD
43	41		P5_3					BCLK
44	42		P5_2					RD
45	43		P5_1					WRH/BHE
46	44		P5_0					WRL/WR
47	45		P4_7					CS3
48	46		P4_6					CS2
49	47		P4_5					CS1
50	48		P4_4					CS0

Table 1.14 Pin Characteristics for 100-Pin Package (2)

Pin No.		Control Pin	Port	Interrupt Pin	Timer Pin	UART Pin	Analog Pin	Bus Control Pin
FP	GP							
51	49		P4_3					A19
52	50		P4_2					A18
53	51		P4_1					A17
54	52		P4_0					A16
55	53		P3_7					A15
56	54		P3_6					A14
57	55		P3_5					A13
58	56		P3_4					A12
59	57		P3_3					A11
60	58		P3_2					A10
61	59		P3_1					A9
62	60	VCC2						
63	61		P3_0					A8(/-D7)
64	62	VSS						
65	63		P2_7				AN2_7	A7(/D7/D6)
66	64		P2_6				AN2_6	A6(/D6/D5)
67	65		P2_5				AN2_5	A5(/D5/D4)
68	66		P2_4				AN2_4	A4(/D4/D3)
69	67		P2_3				AN2_3	A3(/D3/D2)
70	68		P2_2				AN2_2	A2(/D2/D1)
71	69		P2_1				AN2_1	A1(/D1/D0)
72	70		P2_0				AN2_0	A0(/D0/-)
73	71		P1_7	$\overline{\text{INT5}}$				D15
74	72		P1_6	$\overline{\text{INT4}}$				D14
75	73		P1_5	$\overline{\text{INT3}}$				D13
76	74		P1_4					D12
77	75		P1_3					D11
78	76		P1_2					D10
79	77		P1_1					D9
80	78		P1_0					D8
81	79		P0_7				AN0_7	D7
82	80		P0_6				AN0_6	D6
83	81		P0_5				AN0_5	D5
84	82		P0_4				AN0_4	D4
85	83		P0_3				AN0_3	D3
86	84		P0_2				AN0_2	D2
87	85		P0_1				AN0_1	D1
88	86		P0_0				AN0_0	D0
89	87		P10_7	$\overline{\text{KI3}}$			AN7	
90	88		P10_6	$\overline{\text{KI2}}$			AN6	
91	89		P10_5	$\overline{\text{KI1}}$			AN5	
92	90		P10_4	$\overline{\text{KI0}}$			AN4	
93	91		P10_3				AN3	
94	92		P10_2				AN2	
95	93		P10_1				AN1	
96	94	AVSS						
97	95		P10_0				AN0	
98	96	VREF						
99	97	AVCC						
100	98		P9_7			SIN4	$\overline{\text{ADTRG}}$	

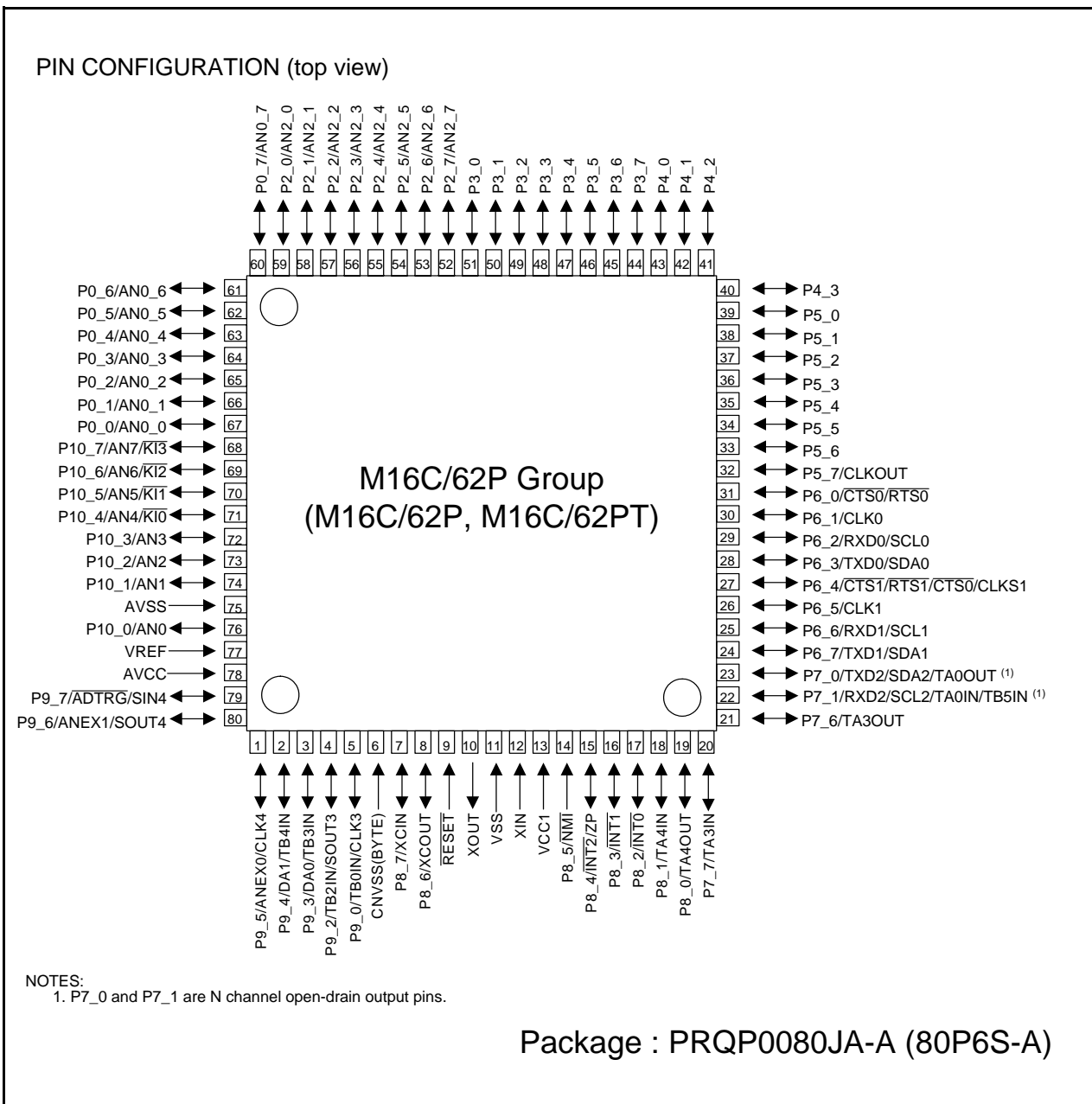


Figure 1.9 Pin Configuration (Top View)

Table 1.15 Pin Characteristics for 80-Pin Package (1)

Pin No.	Control Pin	Port	Interrupt Pin	Timer Pin	UART Pin	Analog Pin	Bus Control Pin
1		P9_5			CLK4	ANEX0	
2		P9_4		TB4IN		DA1	
3		P9_3		TB3IN		DA0	
4		P9_2		TB2IN	SOUT3		
5		P9_0		TB0IN	CLK3		
6	CNVSS (BYTE)						
7	XCIN	P8_7					
8	XCOUT	P8_6					
9	RESET						
10	XOUT						
11	VSS						
12	XIN						
13	VCC1						
14		P8_5	NMI				
15		P8_4	INT2	ZP			
16		P8_3	INT1				
17		P8_2	INT0				
18		P8_1		TA4IN			
19		P8_0		TA4OUT			
20		P7_7		TA3IN			
21		P7_6		TA3OUT			
22		P7_1		TA0IN/TB5IN	RXD2/SDA2		
23		P7_0		TA0OUT	TXD2/SDA2		
24		P6_7			TXD1/SDA1		
25		P6_6			RXD1/SCL1		
26		P6_5			CLK1		
27		P6_4			CTS1/RTS1/CTS0/CLKS1		
28		P6_3			TXD0/SDA0		
29		P6_2			RXD0/SCL0		
30		P6_1			CLK0		
31		P6_0			CTS0/RTS0		
32		P5_7					CLKOUT
33		P5_6					
34		P5_5					
35		P5_4					
36		P5_3					
37		P5_2					
38		P5_1					
39		P5_0					
40		P4_3					
41		P4_2					
42		P4_1					
43		P4_0					
44		P3_7					
45		P3_6					
46		P3_5					
47		P3_4					
48		P3_3					
49		P3_2					
50		P3_1					

Table 1.16 Pin Characteristics for 80-Pin Package (2)

Pin No.	Control Pin	Port	Interrupt Pin	Timer Pin	UART Pin	Analog Pin	Bus Control Pin
51		P3_0					
52		P2_7				AN2_7	
53		P2_6				AN2_6	
54		P2_5				AN2_5	
55		P2_4				AN2_4	
56		P2_3				AN2_3	
57		P2_2				AN2_2	
58		P2_1				AN2_1	
59		P2_0				AN2_0	
60		P0_7				AN0_7	
61		P0_6				AN0_6	
62		P0_5				AN0_5	
63		P0_4				AN0_4	
64		P0_3				AN0_3	
65		P0_2				AN0_2	
66		P0_1				AN0_1	
67		P0_0				AN0_0	
68		P10_7	$\overline{KI3}$			AN7	
69		P10_6	$\overline{KI2}$			AN6	
70		P10_5	$\overline{KI1}$			AN5	
71		P10_4	$\overline{KI0}$			AN4	
72		P10_3				AN3	
73		P10_2				AN2	
74		P10_1				AN1	
75	AVSS						
76		P10_0				AN0	
77	VREF						
78	AVCC						
79		P9_7			SIN4	\overline{ADTRG}	
80		P9_6			SOUT4	ANEX1	

1.6 Pin Description

Table 1.17 Pin Description (100-pin and 128-pin Version) (1)

Signal Name	Pin Name	I/O Type	Power Supply ⁽³⁾	Description
Power supply input	VCC1,VCC2 VSS	I	–	Apply 2.7 to 5.5 V to the VCC1 and VCC2 pins and 0 V to the VSS pin. The VCC apply condition is that $VCC1 \geq VCC2$. (1, 2)
Analog power supply input	AVCC AVSS	I	VCC1	Applies the power supply for the A/D converter. Connect the AVCC pin to VCC1. Connect the AVSS pin to VSS.
Reset input	RESET	I	VCC1	The microcomputer is in a reset state when applying "L" to the this pin.
CNVSS	CNVSS	I	VCC1	Switches processor mode. Connect this pin to VSS to when after a reset to start up in single-chip mode. Connect this pin to VCC1 to start up in microprocessor mode.
External data bus width select input	BYTE	I	VCC1	Switches the data bus in external memory space. The data bus is 16 bits long when the this pin is held "L" and 8 bits long when the this pin is held "H". Set it to either one. Connect this pin to VSS when an single-chip mode.
Bus control pins ⁽⁴⁾	D0 to D7	I/O	VCC2	Inputs and outputs data (D0 to D7) when these pins are set as the separate bus.
	D8 to D15	I/O	VCC2	Inputs and outputs data (D8 to D15) when external 16-bit data bus is set as the separate bus.
	A0 to A19	O	VCC2	Output address bits (A0 to A19).
	A0/D0 to A7/D7	I/O	VCC2	Input and output data (D0 to D7) and output address bits (A0 to A7) by timesharing when external 8-bit data bus are set as the multiplexed bus.
	A1/D0 to A8/D7	I/O	VCC2	Input and output data (D0 to D7) and output address bits (A1 to A8) by timesharing when external 16-bit data bus are set as the multiplexed bus.
	CS0 to CS3	O	VCC2	Output CS0 to CS3 signals. CS0 to CS3 are chip-select signals to specify an external space.
	WRL/WR WRH/BHE RD	O	VCC2	Output WRL, WRH, (WR, BHE), RD signals. WRL and WRH or BHE and WR can be switched by program. <ul style="list-style-type: none"> WRL, WRH and RD are selected The WRL signal becomes "L" by writing data to an even address in an external memory space. The WRH signal becomes "L" by writing data to an odd address in an external memory space. The RD pin signal becomes "L" by reading data in an external memory space. WR, BHE and RD are selected The WR signal becomes "L" by writing data in an external memory space. The RD signal becomes "L" by reading data in an external memory space. The BHE signal becomes "L" by accessing an odd address. Select WR, BHE and RD for an external 8-bit data bus.
	ALE	O	VCC2	ALE is a signal to latch the address.
	HOLD	I	VCC2	While the HOLD pin is held "L", the microcomputer is placed in a hold state.
	HLDA	O	VCC2	In a hold state, HLDA outputs a "L" signal.
RDY	I	VCC2	While applying a "L" signal to the RDY pin, the microcomputer is placed in a wait state.	

I : Input O : Output I/O : Input and output

Power Supply : Power supplies which relate to the external bus pins are separated as VCC2, thus they can be interfaced using the different voltage as VCC1.

NOTES:

1. In this manual, hereafter, VCC refers to VCC1 unless otherwise noted.
2. In M16C/62PT, apply 4.0 to 5.5 V to the VCC1 and VCC2 pins. Also the apply condition is that $VCC1 = VCC2$.
3. When use $VCC1 > VCC2$, contacts due to some points or restrictions to be checked.
4. Bus control pins in M16C/62PT cannot be used.

Table 1.18 Pin Description (100-pin and 128-pin Version) (2)

Signal Name	Pin Name	I/O Type	Power Supply ⁽¹⁾	Description
Main clock input	XIN	I	VCC1	I/O pins for the main clock generation circuit. Connect a ceramic resonator or crystal oscillator between XIN and XOUT ⁽³⁾ . To use the external clock, input the clock from XIN and leave XOUT open.
Main clock output	XOUT	O	VCC1	
Sub clock input	XCIN	I	VCC1	I/O pins for a sub clock oscillation circuit. Connect a crystal oscillator between XCIN and XCOU ⁽³⁾ . To use the external clock, input the clock from XCIN and leave XCOU open.
Sub clock output	XCOU	O	VCC1	
BCLK output ⁽²⁾	BCLK	O	VCC2	Outputs the BCLK signal.
Clock output	CLKOUT	O	VCC2	The clock of the same cycle as f _C , f ₈ , or f ₃₂ is outputted.
$\overline{\text{INT}}$ interrupt input	$\overline{\text{INT}}_0$ to $\overline{\text{INT}}_2$	I	VCC1	Input pins for the $\overline{\text{INT}}$ interrupt.
	$\overline{\text{INT}}_3$ to $\overline{\text{INT}}_5$	I	VCC2	
$\overline{\text{NMI}}$ interrupt input	$\overline{\text{NMI}}$	I	VCC1	Input pin for the $\overline{\text{NMI}}$ interrupt. Pin states can be read by the P8_5 bit in the P8 register.
Key input interrupt input	$\overline{\text{KI}}_0$ to $\overline{\text{KI}}_3$	I	VCC1	Input pins for the key input interrupt.
Timer A	TA0OUT to TA4OUT	I/O	VCC1	These are timer A0 to timer A4 I/O pins. (however, output of TA0OUT for the N-channel open drain output.)
	TA0IN to TA4IN	I	VCC1	These are timer A0 to timer A4 input pins.
	ZP	I	VCC1	Input pin for the Z-phase.
Timer B	TB0IN to TB5IN	I	VCC1	These are timer B0 to timer B5 input pins.
Three-phase motor control output	U, $\overline{\text{U}}$, V, $\overline{\text{V}}$, W, $\overline{\text{W}}$	O	VCC1	These are Three-phase motor control output pins.
Serial interface	$\overline{\text{CTS}}_0$ to $\overline{\text{CTS}}_2$	I	VCC1	These are send control input pins.
	$\overline{\text{RTS}}_0$ to $\overline{\text{RTS}}_2$	O	VCC1	These are receive control output pins.
	CLK0 to CLK4	I/O	VCC1	These are transfer clock I/O pins.
	RXD0 to RXD2	I	VCC1	These are serial data input pins.
	SIN3, SIN4	I	VCC1	These are serial data input pins.
	TXD0 to TXD2	O	VCC1	These are serial data output pins. (however, output of TXD2 for the N-channel open drain output.)
	SOUT3, SOUT4	O	VCC1	These are serial data output pins.
	CLKS1	O	VCC1	This is output pin for transfer clock output from multiple pins function.
I ² C mode	SDA0 to SDA2	I/O	VCC1	These are serial data I/O pins. (however, output of SDA2 for the N-channel open drain output.)
	SCL0 to SCL2	I/O	VCC1	These are transfer clock I/O pins. (however, output of SCL2 for the N-channel open drain output.)

I : Input O : Output I/O : Input and output

NOTES:

1. When use VCC1 > VCC2, contacts due to some points or restrictions to be checked.
2. This pin function in M16C/62PT cannot be used.
3. Ask the oscillator maker the oscillation characteristic.

Table 1.19 Pin Description (100-pin and 128-pin Version) (3)

Signal Name	Pin Name	I/O Type	Power Supply ⁽¹⁾	Description
Reference voltage input	VREF	I	VCC1	Applies the reference voltage for the A/D converter and D/A converter.
A/D converter	AN0 to AN7, AN0_0 to AN0_7, AN2_0 to AN2_7	I	VCC1	Analog input pins for the A/D converter.
	$\overline{\text{ADTRG}}$	I	VCC1	This is an A/D trigger input pin.
	ANEX0	I/O	VCC1	This is the extended analog input pin for the A/D converter, and is the output in external op-amp connection mode.
	ANEX1	I	VCC1	This is the extended analog input pin for the A/D converter.
D/A converter	DA0, DA1	O	VCC1	This is the output pin for the D/A converter.
I/O port	P0_0 to P0_7, P1_0 to P1_7, P2_0 to P2_7, P3_0 to P3_7, P4_0 to P4_7, P5_0 to P5_7, P12_0 to P12_7 (2), P13_0 to P13_7 (2)	I/O	VCC2	8-bit I/O ports in CMOS, having a direction register to select an input or output. Each pin is set as an input port or output port. An input port can be set for a pull-up or for no pull-up in 4-bit unit by program.
	P6_0 to P6_7, P7_0 to P7_7, P9_0 to P9_7, P10_0 to P10_7, P11_0 to P11_7 (2)	I/O	VCC1	8-bit I/O ports having equivalent functions to P0. (however, output of P7_0 and P7_1 for the N-channel open drain output.)
	P8_0 to P8_4, P8_6, P8_7, P14_0, P14_1(2)	I/O	VCC1	I/O ports having equivalent functions to P0.
Input port	P8_5	I	VCC1	Input pin for the $\overline{\text{NMI}}$ interrupt. Pin states can be read by the P8_5 bit in the P8 register.

I : Input O : Output I/O : Input and output

NOTES:

1. When use VCC1 > VCC2, contacts due to some points or restrictions to be checked.
2. Ports P11 to P14 in M16C/62P (100-pin version) and M16C/62PT (100-pin version) cannot be used.

Table 1.20 Pin Description (80-pin Version) (1) (1)

Signal Name	Pin Name	I/O Type	Power Supply	Description
Power supply input	VCC1, VSS	I	–	Apply 2.7 to 5.5 V to the VCC1 pin and 0 V to the VSS pin. (1, 2)
Analog power supply input	AVCC AVSS	I	VCC1	Applies the power supply for the A/D converter. Connect the AVCC pin to VCC1. Connect the AVSS pin to VSS.
Reset input	$\overline{\text{RESET}}$	I	VCC1	The microcomputer is in a reset state when applying “L” to the this pin.
CNVSS	CNVSS (BYTE)	I	VCC1	Switches processor mode. Connect this pin to VSS to when after a reset to start up in single-chip mode. Connect this pin to VCC1 to start up in microprocessor mode. As for the BYTE pin of the 80-pin versions, pull-up processing is performed within the microcomputer.
Main clock input	XIN	I	VCC1	I/O pins for the main clock generation circuit. Connect a ceramic resonator or crystal oscillator between XIN and XOUT (3). To use the external clock, input the clock from XIN and leave XOUT open.
Main clock output	XOUT	O	VCC1	
Sub clock input	XCIN	I	VCC1	I/O pins for a sub clock oscillation circuit. Connect a crystal oscillator between XCIN and XCOU (3). To use the external clock, input the clock from XCIN and leave XCOU open.
Sub clock output	XCOU	O	VCC1	
Clock output	CLKOUT	O	VCC2	The clock of the same cycle as fC, f8, or f32 is outputted.
$\overline{\text{INT}}$ interrupt input	$\overline{\text{INT0}}$ to $\overline{\text{INT2}}$	I	VCC1	Input pins for the $\overline{\text{INT}}$ interrupt.
$\overline{\text{NMI}}$ interrupt input	$\overline{\text{NMI}}$	I	VCC1	Input pin for the $\overline{\text{NMI}}$ interrupt.
Key input interrupt input	$\overline{\text{KI0}}$ to $\overline{\text{KI3}}$	I	VCC1	Input pins for the key input interrupt.
Timer A	TA0OUT, TA3OUT, TA4OUT	I/O	VCC1	These are Timer A0, Timer A3 and Timer A4 I/O pins. (however, output of TA0OUT for the N-channel open drain output.)
	TA0IN, TA3IN, TA4IN	I	VCC1	These are Timer A0, Timer A3 and Timer A4 input pins.
	ZP	I	VCC1	Input pin for the Z-phase.
Timer B	TB0IN, TB2IN to TB5IN	I	VCC1	These are Timer B0, Timer B2 to Timer B5 input pins.
Serial interface	$\overline{\text{CTS0}}$ to $\overline{\text{CTS1}}$	I	VCC1	These are send control input pins.
	$\overline{\text{RTS0}}$ to $\overline{\text{RTS1}}$	O	VCC1	These are receive control output pins.
	CLK0, CLK1, CLK3, CLK4	I/O	VCC1	These are transfer clock I/O pins.
	RXD0 to RXD2	I	VCC1	These are serial data input pins.
	SIN4	I	VCC1	This is serial data input pin.
	TXD0 to TXD2	O	VCC1	These are serial data output pins. (however, output of TXD2 for the N-channel open drain output.)
	SOUT3, SOUT4	O	VCC1	These are serial data output pins.
	CLKS1	O	VCC1	This is output pin for transfer clock output from multiple pins function.
I ² C mode	SDA0 to SDA2	I/O	VCC1	These are serial data I/O pins. (however, output of SDA2 for the N-channel open drain output.)
	SCL0 to SCL2	I/O	VCC1	These are transfer clock I/O pins. (however, output of SCL2 for the N-channel open drain output.)

I : Input O : Output I/O : Input and output

NOTES:

1. In this manual, hereafter, VCC refers to VCC1 unless otherwise noted.
2. In M16C/62PT, apply 4.0 to 5.5 V to the VCC1 pin.
3. Ask the oscillator maker the oscillation characteristic.

Table 1.21 Pin Description (80-pin Version) (2)

Signal Name	Pin Name	I/O Type	Power Supply ⁽¹⁾	Description
Reference voltage input	VREF	I	VCC1	Applies the reference voltage for the A/D converter and D/A converter.
A/D converter	AN0 to AN7, AN0_0 to AN0_7, AN2_0 to AN2_7	I	VCC1	Analog input pins for the A/D converter.
	$\overline{\text{ADTRG}}$	I	VCC1	This is an A/D trigger input pin.
	ANEX0	I/O	VCC1	This is the extended analog input pin for the A/D converter, and is the output in external op-amp connection mode.
	ANEX1	I	VCC1	This is the extended analog input pin for the A/D converter.
D/A converter	DA0, DA1	O	VCC1	This is the output pin for the D/A converter.
I/O port ⁽¹⁾	P0_0 to P0_7, P2_0 to P2_7, P3_0 to P3_7, P5_0 to P5_7, P6_0 to P6_7, P10_0 to P10_7	I/O	VCC1	8-bit I/O ports in CMOS, having a direction register to select an input or output. Each pin is set as an input port or output port. An input port can be set for a pull-up or for no pull-up in 4-bit unit by program.
	P8_0 to P8_4, P8_6, P8_7, P9_0, P9_2 to P9_7	I/O	VCC1	I/O ports having equivalent functions to P0.
	P4_0 to P4_3, P7_0, P7_1, P7_6, P7_7	I/O	VCC1	I/O ports having equivalent functions to P0. (however, output of P7_0 and P7_1 for the N-channel open drain output.)
Input port	P8_5	I	VCC1	Input pin for the $\overline{\text{NMI}}$ interrupt. Pin states can be read by the P8_5 bit in the P8 register.

I : Input O : Output I/O : Input and output

NOTES:

1. There is no external connections for port P1, P4_4 to P4_7, P7_2 to P7_5 and P9_1 in 80-pin version. Set the direction bits in these ports to "1" (output mode), and set the output data to "0" ("L") using the program.

2. Central Processing Unit (CPU)

Figure 2.1 shows the CPU registers. The CPU has 13 registers. Of these, R0, R1, R2, R3, A0, A1 and FB comprise a register bank. There are two register banks.

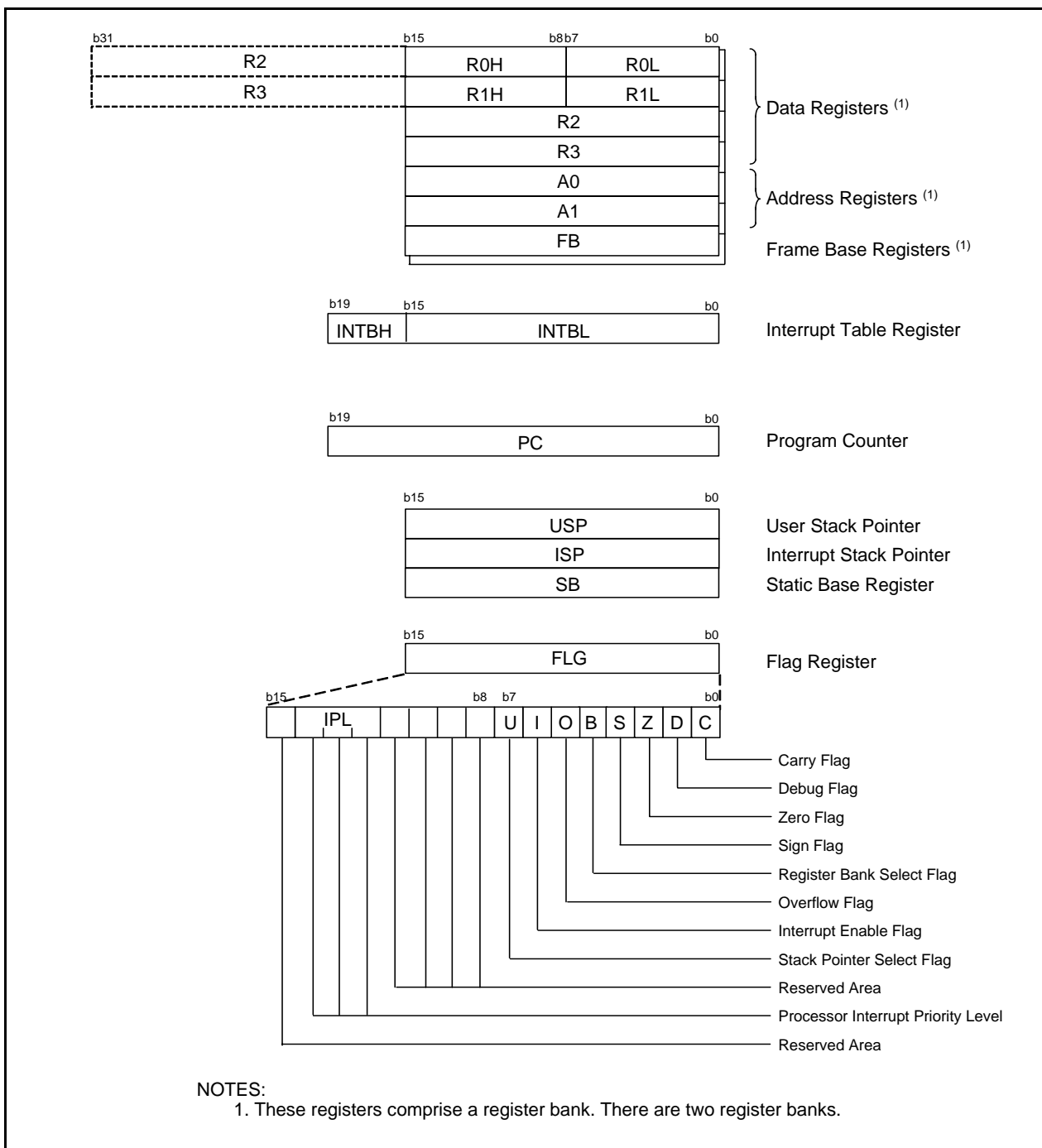


Figure 2.1 Central Processing Unit Register

2.1 Data Registers (R0, R1, R2 and R3)

The R0 register consists of 16 bits, and is used mainly for transfers and arithmetic/logic operations. R1 to R3 are the same as R0.

The R0 register can be separated between high (R0H) and low (R0L) for use as two 8-bit data registers.

R1H and R1L are the same as R0H and R0L. Conversely, R2 and R0 can be combined for use as a 32-bit data register (R2R0). R3R1 is the same as R2R0.

2.2 Address Registers (A0 and A1)

The register A0 consists of 16 bits, and is used for address register indirect addressing and address register relative addressing. They also are used for transfers and logic/logic operations. A1 is the same as A0.

In some instructions, registers A1 and A0 can be combined for use as a 32-bit address register (A1A0).

2.3 Frame Base Register (FB)

FB is configured with 16 bits, and is used for FB relative addressing.

2.4 Interrupt Table Register (INTB)

INTB is configured with 20 bits, indicating the start address of an interrupt vector table.

2.5 Program Counter (PC)

PC is configured with 20 bits, indicating the address of an instruction to be executed.

2.6 User Stack Pointer (USP) and Interrupt Stack Pointer (ISP)

Stack pointer (SP) comes in two types: USP and ISP, each configured with 16 bits.

Your desired type of stack pointer (USP or ISP) can be selected by the U flag of FLG.

2.7 Static Base Register (SB)

SB is configured with 16 bits, and is used for SB relative addressing.

2.8 Flag Register (FLG)

FLG consists of 11 bits, indicating the CPU status.

2.8.1 Carry Flag (C Flag)

This flag retains a carry, borrow, or shift-out bit that has occurred in the arithmetic/logic unit.

2.8.2 Debug Flag (D Flag)

The D flag is used exclusively for debugging purpose. During normal use, it must be set to "0".

2.8.3 Zero Flag (Z Flag)

This flag is set to "1" when an arithmetic operation resulted in 0; otherwise, it is "0".

2.8.4 Sign Flag (S Flag)

This flag is set to "1" when an arithmetic operation resulted in a negative value; otherwise, it is "0".

2.8.5 Register Bank Select Flag (B Flag)

Register bank 0 is selected when this flag is "0"; register bank 1 is selected when this flag is "1".

2.8.6 Overflow Flag (O Flag)

This flag is set to "1" when the operation resulted in an overflow; otherwise, it is "0".

2.8.7 Interrupt Enable Flag (I Flag)

This flag enables a maskable interrupt.

Maskable interrupts are disabled when the I flag is "0", and are enabled when the I flag is "1". The I flag is cleared to "0" when the interrupt request is accepted.

2.8.8 Stack Pointer Select Flag (U Flag)

ISP is selected when the U flag is “0”; USP is selected when the U flag is “1”.

The U flag is cleared to “0” when a hardware interrupt request is accepted or an INT instruction for software interrupt Nos. 0 to 31 is executed.

2.8.9 Processor Interrupt Priority Level (IPL)

IPL is configured with three bits, for specification of up to eight processor interrupt priority levels from level 0 to level 7.

If a requested interrupt has priority greater than IPL, the interrupt is enabled.

2.8.10 Reserved Area

When write to this bit, write “0”. When read, its content is indeterminate.

3. Memory

Figure 3.1 is a Memory Map of the M16C/62P group. The address space extends the 1M bytes from address 00000h to FFFFFh.

The internal ROM is allocated in a lower address direction beginning with address FFFFFh. For example, a 64-Kbyte internal ROM is allocated to the addresses from F0000h to FFFFFh.

As for the flash memory version, 4-Kbyte space (block A) exists in 0F000h to 0FFFFh. 4-Kbyte space is mainly for storing data. In addition to storing data, 4-Kbyte space also can store programs.

The fixed interrupt vector table is allocated to the addresses from FFFDCh to FFFFFh. Therefore, store the start address of each interrupt routine here.

The internal RAM is allocated in an upper address direction beginning with address 00400h. For example, a 10-Kbyte internal RAM is allocated to the addresses from 00400h to 02BFFh. In addition to storing data, the internal RAM also stores the stack used when calling subroutines and when interrupts are generated.

The SRF is allocated to the addresses from 00000h to 003FFh. Peripheral function control registers are located here. Of the SFR, any area which has no functions allocated is reserved for future use and cannot be used by users.

The special page vector table is allocated to the addresses from FFE00h to FFFDBh. This vector is used by the JMPS or JSRS instruction. For details, refer to the **M16C/60 and M16C/20 Series Software Manual**.

In memory expansion and microprocessor modes, some areas are reserved for future use and cannot be used by users. Use M16C/62P (80-pin version) and M16C/62PT in single-chip mode. The memory expansion and microprocessor modes cannot be used



Figure 3.1 Memory Map

4. Special Function Register (SFR)

SFR(Special Function Register) is the control register of peripheral functions. Tables 4.1 to 4.6 list the SFR information.

Table 4.1 SFR Information (1) (1)

Address	Register	Symbol	After Reset
0000h			
0001h			
0002h			
0003h			
0004h	Processor Mode Register 0 (2)	PM0	0000000b(CNVSS pin is "L") 0000011b(CNVSS pin is "H")
0005h	Processor Mode Register 1	PM1	00001000b
0006h	System Clock Control Register 0	CM0	01001000b
0007h	System Clock Control Register 1	CM1	00100000b
0008h	Chip Select Control Register (6)	CSR	00000001b
0009h	Address Match Interrupt Enable Register	AIER	XXXXXX00b
000Ah	Protect Register	PRCR	XX000000b
000Bh	Data Bank Register (6)	DBR	00h
000Ch	Oscillation Stop Detection Register (3)	CM2	0X000000b
000Dh			
000Eh	Watchdog Timer Start Register	WDTS	XXh
000Fh	Watchdog Timer Control Register	WDC	00XXXXXXb (4)
0010h	Address Match Interrupt Register 0	RMAD0	00h
0011h			00h
0012h			X0h
0013h			
0014h	Address Match Interrupt Register 1	RMAD1	00h
0015h			00h
0016h			X0h
0017h			
0018h			
0019h	Voltage Detection Register 1 (5, 6)	VCR1	00001000b
001Ah	Voltage Detection Register 2 (5, 6)	VCR2	00h
001Bh	Chip Select Expansion Control Register (6)	CSE	00h
001Ch	PLL Control Register 0	PLC0	0001X010b
001Dh			
001Eh	Processor Mode Register 2	PM2	XXX00000b
001Fh	Low Voltage Detection Interrupt Register (6)	D4INT	00h
0020h	DMA0 Source Pointer	SAR0	XXh
0021h			XXh
0022h			XXh
0023h			
0024h	DMA0 Destination Pointer	DAR0	XXh
0025h			XXh
0026h			XXh
0027h			
0028h	DMA0 Transfer Counter	TCR0	XXh
0029h			XXh
002Ah			
002Bh			
002Ch	DMA0 Control Register	DM0CON	00000X00b
002Dh			
002Eh			
002Fh			
0030h	DMA1 Source Pointer	SAR1	XXh
0031h			XXh
0032h			XXh
0033h			
0034h	DMA1 Destination Pointer	DAR1	XXh
0035h			XXh
0036h			XXh
0037h			
0038h	DMA1 Transfer Counter	TCR1	XXh
0039h			XXh
003Ah			
003Bh			
003Ch	DMA1 Control Register	DM1CON	00000X00b
003Dh			
003Eh			
003Fh			

NOTES:

1. The blank areas are reserved and cannot be accessed by users.
2. The PM00 and PM01 bits do not change at software reset, watchdog timer reset and oscillation stop detection reset.
3. The CM20, CM21, and CM27 bits do not change at oscillation stop detection reset.
4. The WDC5 bit is "0" (cold start) immediately after power-on. It can only be set to "1" in a program.
5. This register does not change at software reset, watchdog timer reset and oscillation stop detection reset.
6. This register in M16C/62PT cannot be used.

X : Nothing is mapped to this bit

Table 4.2 SFR Information (2) (1)

Address	Register	Symbol	After Reset
0040h			
0041h			
0042h			
0043h			
0044h	INT3 Interrupt Control Register	INT3IC	XX00X000b
0045h	Timer B5 Interrupt Control Register	TB5IC	XXXXX000b
0046h	Timer B4 Interrupt Control Register, UART1 BUS Collision Detection Interrupt Control Register	TB4IC, U1BCNIC	XXXXX000b
0047h	Timer B3 Interrupt Control Register, UART0 BUS Collision Detection Interrupt Control Register	TB3IC, U0BCNIC	XXXXX000b
0048h	SI/O4 Interrupt Control Register, INT5 Interrupt Control Register	S4IC, INT5IC	XX00X000b
0049h	SI/O3 Interrupt Control Register, INT4 Interrupt Control Register	S3IC, INT4IC	XX00X000b
004Ah	UART2 Bus Collision Detection Interrupt Control Register	BCNIC	XXXXX000b
004Bh	DMA0 Interrupt Control Register	DM0IC	XXXXX000b
004Ch	DMA1 Interrupt Control Register	DM1IC	XXXXX000b
004Dh	Key Input Interrupt Control Register	KUPIC	XXXXX000b
004Eh	A/D Conversion Interrupt Control Register	ADIC	XXXXX000b
004Fh	UART2 Transmit Interrupt Control Register	S2TIC	XXXXX000b
0050h	UART2 Receive Interrupt Control Register	S2RIC	XXXXX000b
0051h	UART0 Transmit Interrupt Control Register	S0TIC	XXXXX000b
0052h	UART0 Receive Interrupt Control Register	S0RIC	XXXXX000b
0053h	UART1 Transmit Interrupt Control Register	S1TIC	XXXXX000b
0054h	UART1 Receive Interrupt Control Register	S1RIC	XXXXX000b
0055h	Timer A0 Interrupt Control Register	TA0IC	XXXXX000b
0056h	Timer A1 Interrupt Control Register	TA1IC	XXXXX000b
0057h	Timer A2 Interrupt Control Register	TA2IC	XXXXX000b
0058h	Timer A3 Interrupt Control Register	TA3IC	XXXXX000b
0059h	Timer A4 Interrupt Control Register	TA4IC	XXXXX000b
005Ah	Timer B0 Interrupt Control Register	TB0IC	XXXXX000b
005Bh	Timer B1 Interrupt Control Register	TB1IC	XXXXX000b
005Ch	Timer B2 Interrupt Control Register	TB2IC	XXXXX000b
005Dh	INT0 Interrupt Control Register	INT0IC	XX00X000b
005Eh	INT1 Interrupt Control Register	INT1IC	XX00X000b
005Fh	INT2 Interrupt Control Register	INT2IC	XX00X000b
0060h			
0061h			
0062h			
0063h			
0064h			
0065h			
0066h			
0067h			
0068h			
0069h			
006Ah			
006Bh			
006Ch			
006Dh			
006Eh			
006Fh			
0070h			
0071h			
0072h			
0073h			
0074h			
0075h			
0076h			
0077h			
0078h			
0079h			
007Ah			
007Bh			
007Ch			
007Dh			
007Eh			
007Fh			

NOTES:

- The blank areas are reserved and cannot be accessed by users.

X : Nothing is mapped to this bit

Table 4.3 SFR Information (3) (1)

Address	Register	Symbol	After Reset
0080h			
0081h			
0082h			
0083h			
0084h			
0085h			
0086h			
0087h to 01AFh			
01B0h			
01B1h			
01B2h			
01B3h			
01B4h	Flash Identification Register (2)	FIDR	XXXXXX00b
01B5h	Flash Memory Control Register 1 (2)	FMR1	0X00XX0Xb
01B6h			
01B7h	Flash Memory Control Register 0 (2)	FMR0	00000001b
01B8h	Address Match Interrupt Register 2	RMAD2	00h 00h XXh
01B9h			
01BAh			
01BBh			
01BCh	Address Match Interrupt Enable Register 2	AIER2	XXXXXX00b
01BDh			
01BEh			
01BFh			
01C0h	Address Match Interrupt Register 3	RMAD3	00h 00h XXh
01C1h			
01C2h			
01C3h			
01C4h			
01C5h			
01C6h			
01C7h			
01C8h			
01C9h			
01CAh			
01CBh			
01CCh			
01CDh			
01CEh			
01CFh			
01D0h			
01D1h			
01D2h			
01D3h			
01D4h			
01D5h			
01D6h			
01D7h			
01D8h			
01D9h			
01DAh			
01DBh			
01DCh			
01DDh			
01DEh			
01DFh			
01E0h			
01E1h			
01E2h			
01E3h			
01E4h			
01E5h			
01E6h			
01E7h			
01E8h			
01E9h			
01EAh			
01EBh			
01ECh			
01EDh			
01EEh			
01EFh			
01F0h			
01F1h			
01F2h			
01F3h			
01F4h			
01F5h			
01F6h			
01F7h			
01F8h			
01F9h			
01FAh			
01FBh			
01FCh			
01FDh			
01FEh			
01FFh			
0200h			
0201h			
0202h			
0203h			
0204h			
0205h			
0206h			
0207h			
0208h			
0209h			
020Ah			
020Bh			
020Ch			
020Dh			
020Eh			
020Fh			
0210h			
0211h			
0212h			
0213h			
0214h			
0215h			
0216h			
0217h			
0218h			
0219h			
021Ah			
021Bh			
021Ch			
021Dh			
021Eh			
021Fh			
0220h			
0221h			
0222h			
0223h			
0224h			
0225h			
0226h			
0227h			
0228h			
0229h			
022Ah			
022Bh			
022Ch			
022Dh			
022Eh			
022Fh			
0230h			
0231h			
0232h			
0233h			
0234h			
0235h			
0236h			
0237h			
0238h			
0239h			
023Ah			
023Bh			
023Ch			
023Dh			
023Eh			
023Fh			
0240h			
0241h			
0242h			
0243h			
0244h			
0245h			
0246h			
0247h			
0248h			
0249h			
024Ah			
024Bh			
024Ch			
024Dh			
024Eh			
024Fh			
0250h			
0251h			
0252h			
0253h			
0254h			
0255h			
0256h			
0257h			
0258h			
0259h			
025Ah			
025Bh			
025Ch			
025Dh			
025Eh	Peripheral Clock Select Register	PCLKR	00000011b
025Fh			
0260h			
0261h			
0262h			
0263h			
0264h			
0265h			
0266h			
0267h			
0268h			
0269h			
026Ah			
026Bh			
026Ch			
026Dh			
026Eh			
026Fh			
0270h			
0271h			
0272h			
0273h			
0274h			
0275h			
0276h			
0277h			
0278h			
0279h			
027Ah			
027Bh			
027Ch			
027Dh			
027Eh			
027Fh			
0280h			
0281h			
0282h			
0283h			
0284h			
0285h			
0286h			
0287h			
0288h			
0289h			
028Ah			
028Bh			
028Ch			
028Dh			
028Eh			
028Fh			
0290h			
0291h			
0292h			
0293h			
0294h			
0295h			
0296h			
0297h			
0298h			
0299h			
029Ah			
029Bh			
029Ch			
029Dh			
029Eh			
029Fh			
02A0h			
02A1h			
02A2h			
02A3h			
02A4h			
02A5h			
02A6h			
02A7h			
02A8h			
02A9h			
02AAh			
02ABh			
02ACh			
02ADh			
02AEh			
02AFh			
02B0h			
02B1h			
02B2h			
02B3h			
02B4h			
02B5h			
02B6h			
02B7h			
02B8h			
02B9h			
02BAh			
02Bbh			
02BCh			
02BDh			
02BEh			
02BFh			
02C0h			
02C1h			
02C2h			
02C3h			
02C4h			
02C5h			
02C6h			
02C7h			
02C8h			
02C9h			
02CAh			
02CBh			
02CCh			
02CDh			
02CEh			
02CFh			
02D0h			
02D1h			
02D2h			
02D3h			
02D4h			
02D5h			
02D6h			
02D7h			
02D8h			
02D9h			
02DAh			
02DBh			
02DCh			
02Ddh			
02DEh			
02DFh			
02E0h			
02E1h			
02E2h			
02E3h			
02E4h			
02E5h			
02E6h			
02E7h			
02E8h			
02E9h			
02EAh			
02EBh			
02ECh			
02EDh			
02EEh			
02EFh			
02F0h			
02F1h			
02F2h			
02F3h			
02F4h			
02F5h			
02F6h			
02F7h			
02F8h			
02F9h			
02FAh			
02FBh			
02FCh			
02FDh			
02FEh			
02FFh			

NOTES:

1. The blank areas are reserved and cannot be accessed by users.
2. This register is included in the flash memory version.

X : Nothing is mapped to this bit

Table 4.4 SFR Information (4) (1)

Address	Register	Symbol	After Reset
0340h	Timer B3, 4, 5 Count Start Flag	TBSR	000XXXXXb
0341h			
0342h	Timer A1-1 Register	TA11	XXh
0343h			XXh
0344h	Timer A2-1 Register	TA21	XXh
0345h			XXh
0346h	Timer A4-1 Register	TA41	XXh
0347h			XXh
0348h	Three-Phase PWM Control Register 0	INVC0	00h
0349h	Three-Phase PWM Control Register 1	INVC1	00h
034Ah	Three-Phase Output Buffer Register 0	IDB0	00h
034Bh	Three-Phase Output Buffer Register 1	IDB1	00h
034Ch	Dead Time Timer	DTT	XXh
034Dh	Timer B2 Interrupt Occurrence Frequency Set Counter	ICTB2	XXh
034Eh			
034Fh			
0350h	Timer B3 Register	TB3	XXh
0351h			XXh
0352h	Timer B4 Register	TB4	XXh
0353h			XXh
0354h	Timer B5 Register	TB5	XXh
0355h			XXh
0356h			
0357h			
0358h			
0359h			
035Ah			
035Bh	Timer B3 Mode Register	TB3MR	00XX0000b
035Ch	Timer B4 Mode Register	TB4MR	00XX0000b
035Dh	Timer B5 Mode Register	TB5MR	00XX0000b
035Eh	Interrupt Factor Select Register 2	IFSR2A	00XXXXXXb
035Fh	Interrupt Factor Select Register	IFSR	00h
0360h	SI/O3 Transmit/Receive Register	S3TRR	XXh
0361h			
0362h	SI/O3 Control Register	S3C	01000000b
0363h	SI/O3 Bit Rate Generator	S3BRG	XXh
0364h	SI/O4 Transmit/Receive Register	S4TRR	XXh
0365h			
0366h	SI/O4 Control Register	S4C	01000000b
0367h	SI/O4 Bit Rate Generator	S4BRG	XXh
0368h			
0369h			
036Ah			
036Bh			
036Ch	UART0 Special Mode Register 4	U0SMR4	00h
036Dh	UART0 Special Mode Register 3	U0SMR3	000X0X0Xb
036Eh	UART0 Special Mode Register 2	U0SMR2	X0000000b
036Fh	UART0 Special Mode Register	U0SMR	X0000000b
0370h	UART1 Special Mode Register 4	U1SMR4	00h
0371h	UART1 Special Mode Register 3	U1SMR3	000X0X0Xb
0372h	UART1 Special Mode Register 2	U1SMR2	X0000000b
0373h	UART1 Special Mode Register	U1SMR	X0000000b
0374h	UART2 Special Mode Register 4	U2SMR4	00h
0375h	UART2 Special Mode Register 3	U2SMR3	000X0X0Xb
0376h	UART2 Special Mode Register 2	U2SMR2	X0000000b
0377h	UART2 Special Mode Register	U2SMR	X0000000b
0378h	UART2 Transmit/Receive Mode Register	U2MR	00h
0379h	UART2 Bit Rate Generator	U2BRG	XXh
037Ah	UART2 Transmit Buffer Register	U2TB	XXh
037Bh			XXh
037Ch	UART2 Transmit/Receive Control Register 0	U2C0	00001000b
037Dh	UART2 Transmit/Receive Control Register 1	U2C1	00000010b
037Eh	UART2 Receive Buffer Register	U2RB	XXh
037Fh			XXh

NOTES:

- The blank areas are reserved and cannot be accessed by users.

X : Nothing is mapped to this bit

Table 4.5 SFR Information (5) (1)

Address	Register	Symbol	After Reset
0380h	Count Start Flag	TABSR	00h
0381h	Clock Prescaler Reset Fag	CPSRF	0XXXXXXb
0382h	One-Shot Start Flag	ONSF	00h
0383h	Trigger Select Register	TRGSR	00h
0384h	Up-Down Flag	UDF	00h (2)
0385h			
0386h	Timer A0 Register	TA0	XXh
0387h			XXh
0388h	Timer A1 Register	TA1	XXh
0389h			XXh
038Ah	Timer A2 Register	TA2	XXh
038Bh			XXh
038Ch	Timer A3 Register	TA3	XXh
038Dh			XXh
038Eh	Timer A4 Register	TA4	XXh
038Fh			XXh
0390h	Timer B0 Register	TB0	XXh
0391h			XXh
0392h	Timer B1 Register	TB1	XXh
0393h			XXh
0394h	Timer B2 Register	TB2	XXh
0395h			XXh
0396h	Timer A0 Mode Register	TA0MR	00h
0397h	Timer A1 Mode Register	TA1MR	00h
0398h	Timer A2 Mode Register	TA2MR	00h
0399h	Timer A3 Mode Register	TA3MR	00h
039Ah	Timer A4 Mode Register	TA4MR	00h
039Bh	Timer B0 Mode Register	TB0MR	00XX0000b
039Ch	Timer B1 Mode Register	TB1MR	00XX0000b
039Dh	Timer B2 Mode Register	TB2MR	00XX0000b
039Eh	Timer B2 Special Mode Register	TB2SC	XXXXXX00b
039Fh			
03A0h	UART0 Transmit/Receive Mode Register	U0MR	00h
03A1h	UART0 Bit Rate Generator	U0BRG	XXh
03A2h	UART0 Transmit Buffer Register	U0TB	XXh
03A3h			XXh
03A4h	UART0 Transmit/Receive Control Register 0	U0C0	00001000b
03A5h	UART0 Transmit/Receive Control Register 1	U0C1	00XX0010b
03A6h	UART0 Receive Buffer Register	U0RB	XXh
03A7h			XXh
03A8h	UART1 Transmit/Receive Mode Register	U1MR	00h
03A9h	UART1 Bit Rate Generator	U1BRG	XXh
03AAh	UART1 Transmit Buffer Register	U1TB	XXh
03ABh			XXh
03ACh	UART1 Transmit/Receive Control Register 0	U1C0	00001000b
03ADh	UART1 Transmit/Receive Control Register 1	U1C1	00XX0010b
03AEh	UART1 Receive Buffer Register	U1RB	XXh
03AFh			XXh
03B0h	UART Transmit/Receive Control Register 2	UCON	X0000000b
03B1h			
03B2h			
03B3h			
03B4h			
03B5h			
03B6h			
03B7h			
03B8h	DMA0 Request Factor Select Register	DM0SL	00h
03B9h			
03BAh	DMA1 Request Factor Select Register	DM1SL	00h
03BBh			
03BCh	CRC Data Register	CRCD	XXh
03BDh			XXh
03BEh	CRC Input Register	CRCIN	XXh
03BFh			

NOTES:

1. The blank areas are reserved and cannot be accessed by users.
2. Bit 5 in the Up-down flag is "0" by reset. However, The values in these bits when read are indeterminate.

X : Nothing is mapped to this bit

Table 4.6 SFR Information (6) (1)

Address	Register	Symbol	After Reset
03C0h 03C1h	A/D Register 0	AD0	XXh XXh
03C2h 03C3h	A/D Register 1	AD1	XXh XXh
03C4h 03C5h	A/D Register 2	AD2	XXh XXh
03C6h 03C7h	A/D Register 3	AD3	XXh XXh
03C8h 03C9h	A/D Register 4	AD4	XXh XXh
03CAh 03CBh	A/D Register 5	AD5	XXh XXh
03CCh 03CDh	A/D Register 6	AD6	XXh XXh
03CEh 03CFh	A/D Register 7	AD7	XXh XXh
03D0h			
03D1h			
03D2h			
03D3h			
03D4h 03D5h	A/D Control Register 2	ADCON2	00h
03D6h	A/D Control Register 0	ADCON0	00000XXXb
03D7h	A/D Control Register 1	ADCON1	00h
03D8h 03D9h	D/A Register 0	DA0	00h
03DAh 03DBh	D/A Register 1	DA1	00h
03DCh 03DDh	D/A Control Register	DACON	00h
03DEh	Port P14 Control Register ⁽³⁾	PC14	XX00XXXb
03DFh	Pull-Up Control Register 3 ⁽³⁾	PUR3	00h
03E0h	Port P0 Register	P0	XXh
03E1h	Port P1 Register	P1	XXh
03E2h	Port P0 Direction Register	PD0	00h
03E3h	Port P1 Direction Register	PD1	00h
03E4h	Port P2 Register	P2	XXh
03E5h	Port P3 Register	P3	XXh
03E6h	Port P2 Direction Register	PD2	00h
03E7h	Port P3 Direction Register	PD3	00h
03E8h	Port P4 Register	P4	XXh
03E9h	Port P5 Register	P5	XXh
03EAh	Port P4 Direction Register	PD4	00h
03EBh	Port P5 Direction Register	PD5	00h
03ECh	Port P6 Register	P6	XXh
03EDh	Port P7 Register	P7	XXh
03EEh	Port P6 Direction Register	PD6	00h
03EFh	Port P7 Direction Register	PD7	00h
03F0h	Port P8 Register	P8	XXh
03F1h	Port P9 Register	P9	XXh
03F2h	Port P8 Direction Register	PD8	00X00000b
03F3h	Port P9 Direction Register	PD9	00h
03F4h	Port P10 Register	P10	XXh
03F5h	Port P11 Register ⁽³⁾	P11	XXh
03F6h	Port P10 Direction Register	PD10	00h
03F7h	Port P11 Direction Register ⁽³⁾	PD11	00h
03F8h	Port P12 Register ⁽³⁾	P12	XXh
03F9h	Port P13 Register ⁽³⁾	P13	XXh
03FAh	Port P12 Direction Register ⁽³⁾	PD12	00h
03FBh	Port P13 Direction Register ⁽³⁾	PD13	00h
03FCh	Pull-Up Control Register 0	PUR0	00h
03FDh	Pull-Up Control Register 1	PUR1	00000000b ⁽²⁾ 00000010b ⁽²⁾
03FEh	Pull-Up Control Register 2	PUR2	00h
03FFh	Port Control Register	PCR	00h

NOTES:

- The blank areas are reserved and cannot be accessed by users.
- At hardware reset 1 or hardware reset 2, the register is as follows:
 - "00000000b" where "L" is inputted to the CNVSS pin
 - "00000010b" where "H" is inputted to the CNVSS pin
At software reset, watchdog timer reset and oscillation stop detection reset, the register is as follows:
 - "00000000b" where the PM01 to PM00 bits in the PM0 register are "00b" (single-chip mode).
 - "00000010b" where the PM01 to PM00 bits in the PM0 register are "01b" (memory expansion mode) or "11b" (microprocessor mode).
- These registers do not exist in M16C/62P (80-pin version), and M16C/62PT (80-pin version).

X : Nothing is mapped to this bit

5. Electrical Characteristics

5.1 Electrical Characteristics (M16C/62P)

Table 5.1 Absolute Maximum Ratings

Symbol	Parameter		Condition	Rated Value	Unit
V _{cc1} , V _{cc2}	Supply Voltage		V _{cc1} =AV _{cc}	-0.3 to 6.5	V
V _{cc2}	Supply Voltage		V _{cc2}	-0.3 to V _{cc1} +0.1	V
AV _{cc}	Analog Supply Voltage		V _{cc1} =AV _{cc}	-0.3 to 6.5	V
V _i	Input Voltage	RESET, CNVSS, BYTE, P6_0 to P6_7, P7_2 to P7_7, P8_0 to P8_7, P9_0 to P9_7, P10_0 to P10_7, P11_0 to P11_7, P14_0, P14_1, VREF, XIN		-0.3 to V _{cc1} +0.3 ⁽¹⁾	V
		P0_0 to P0_7, P1_0 to P1_7, P2_0 to P2_7, P3_0 to P3_7, P4_0 to P4_7, P5_0 to P5_7, P12_0 to P12_7, P13_0 to P13_7		-0.3 to V _{cc2} +0.3 ⁽¹⁾	V
		P7_0, P7_1		-0.3 to 6.5	V
V _o	Output Voltage	P6_0 to P6_7, P7_2 to P7_7, P8_0 to P8_4, P8_6, P8_7, P9_0 to P9_7, P10_0 to P10_7, P11_0 to P11_7, P14_0, P14_1, XOUT		-0.3 to V _{cc1} +0.3 ⁽¹⁾	V
		P0_0 to P0_7, P1_0 to P1_7, P2_0 to P2_7, P3_0 to P3_7, P4_0 to P4_7, P5_0 to P5_7, P12_0 to P12_7, P13_0 to P13_7		-0.3 to V _{cc2} +0.3 ⁽¹⁾	V
		P7_0, P7_1		-0.3 to 6.5	V
P _d	Power Dissipation		-40°C < T _{opr} ≤ 85°C	300	mW
T _{opr}	Operating Ambient Temperature	When the Microcomputer is Operating		-20 to 85 / -40 to 85	°C
		Flash Program Erase		0 to 60	
T _{stg}	Storage Temperature			-65 to 150	°C

NOTES:

1. There is no external connections for port P1_0 to P1_7, P4_4 to P4_7, P7_2 to P7_5 and P9_1 in 80-pin version.

Table 5.2 Recommended Operating Conditions (1) (1)

Symbol	Parameter		Standard			Unit
			Min.	Typ.	Max.	
V _{CC1} , V _{CC2}	Supply Voltage (V _{CC1} ≥ V _{CC2})		2.7	5.0	5.5	V
AV _{CC}	Analog Supply Voltage			V _{CC1}		V
V _{SS}	Supply Voltage			0		V
AV _{SS}	Analog Supply Voltage			0		V
V _{IH}	HIGH Input Voltage	P3_1 to P3_7, P4_0 to P4_7, P5_0 to P5_7, P12_0 to P12_7, P13_0 to P13_7	0.8V _{CC2}		V _{CC2}	V
		P0_0 to P0_7, P1_0 to P1_7, P2_0 to P2_7, P3_0 (during single-chip mode)	0.8V _{CC2}		V _{CC2}	V
		P0_0 to P0_7, P1_0 to P1_7, P2_0 to P2_7, P3_0 (data input during memory expansion and microprocessor mode)	0.5V _{CC2}		V _{CC2}	V
		P6_0 to P6_7, P7_2 to P7_7, P8_0 to P8_7, P9_0 to P9_7, P10_0 to P10_7, P11_0 to P11_7, P14_0, P14_1, XIN, $\overline{\text{RESET}}$, CNVSS, BYTE	0.8V _{CC1}		V _{CC1}	V
		P7_0, P7_1	0.8V _{CC1}		6.5	V
V _{IL}	LOW Input Voltage	P3_1 to P3_7, P4_0 to P4_7, P5_0 to P5_7, P12_0 to P12_7, P13_0 to P13_7	0		0.2V _{CC2}	V
		P0_0 to P0_7, P1_0 to P1_7, P2_0 to P2_7, P3_0 (during single-chip mode)	0		0.2V _{CC2}	V
		P0_0 to P0_7, P1_0 to P1_7, P2_0 to P2_7, P3_0 (data input during memory expansion and microprocessor mode)	0		0.16V _{CC2}	V
		P6_0 to P6_7, P7_0 to P7_7, P8_0 to P8_7, P9_0 to P9_7, P10_0 to P10_7, P11_0 to P11_7, P14_0, P14_1, XIN, $\overline{\text{RESET}}$, CNVSS, BYTE	0		0.2V _{CC}	V
I _{OH(peak)}	HIGH Peak Output Current	P0_0 to P0_7, P1_0 to P1_7, P2_0 to P2_7, P3_0 to P3_7, P4_0 to P4_7, P5_0 to P5_7, P6_0 to P6_7, P7_2 to P7_7, P8_0 to P8_4, P8_6, P8_7, P9_0 to P9_7, P10_0 to P10_7, P11_0 to P11_7, P12_0 to P12_7, P13_0 to P13_7, P14_0, P14_1			-10.0	mA
I _{OH(avg)}	HIGH Average Output Current	P0_0 to P0_7, P1_0 to P1_7, P2_0 to P2_7, P3_0 to P3_7, P4_0 to P4_7, P5_0 to P5_7, P6_0 to P6_7, P7_2 to P7_7, P8_0 to P8_4, P8_6, P8_7, P9_0 to P9_7, P10_0 to P10_7, P11_0 to P11_7, P12_0 to P12_7, P13_0 to P13_7, P14_0, P14_1			-5.0	mA
I _{OL(peak)}	LOW Peak Output Current	P0_0 to P0_7, P1_0 to P1_7, P2_0 to P2_7, P3_0 to P3_7, P4_0 to P4_7, P5_0 to P5_7, P6_0 to P6_7, P7_0 to P7_7, P8_0 to P8_4, P8_6, P8_7, P9_0 to P9_7, P10_0 to P10_7, P11_0 to P11_7, P12_0 to P12_7, P13_0 to P13_7, P14_0, P14_1			10.0	mA
I _{OL(avg)}	LOW Average Output Current	P0_0 to P0_7, P1_0 to P1_7, P2_0 to P2_7, P3_0 to P3_7, P4_0 to P4_7, P5_0 to P5_7, P6_0 to P6_7, P7_0 to P7_7, P8_0 to P8_4, P8_6, P8_7, P9_0 to P9_7, P10_0 to P10_7, P11_0 to P11_7, P12_0 to P12_7, P13_0 to P13_7, P14_0, P14_1			5.0	mA

NOTES:

1. Referenced to V_{CC1} = V_{CC2} = 2.7 to 5.5V at T_{opr} = -20 to 85°C / -40 to 85°C unless otherwise specified.
2. The Average Output Current is the mean value within 100ms.
3. The total I_{OL(peak)} for ports P0, P1, P2, P8_6, P8_7, P9, P10, P11, P14_0, and P14_1 must be 80mA max. The total I_{OL(peak)} for ports P3, P4, P5, P6, P7, P8_0 to P8_4, P12, and P13 must be 80mA max. The total I_{OH(peak)} for ports P0, P1, and P2 must be -40mA max. The total I_{OH(peak)} for ports P3, P4, P5, P12, and P13 must be -40mA max. The total I_{OH(peak)} for ports P6, P7, and P8_0 to P8_4 must be -40mA max. The total I_{OH(peak)} for ports P8_6, P8_7, P9, P10, P14_0, and P14_1 must be -40mA max. Set Average Output Current to 1/2 of peak. The total I_{OH(peak)} for ports P8_6, P8_7, P9, P10, P11, P14_0, and P14_1 must be -40mA max.
As for 80-pin version, the total I_{OL(peak)} for all ports and I_{OH(peak)} must be 80mA. max. due to one V_{CC} and one V_{SS}.
4. There is no external connections for port P1_0 to P1_7, P4_4 to P4_7, P7_2 to P7_5 and P9_1 in 80-pin version.

Table 5.3 Recommended Operating Conditions (2) (1)

Symbol	Parameter		Standard			Unit
			Min.	Typ.	Max.	
f(XIN)	Main Clock Input Oscillation Frequency (2)	VCC1=3.0V to 5.5V	0		16	MHz
		VCC1=2.7V to 3.0V	0		20×VCC1 -44	MHz
f(XCIN)	Sub-Clock Oscillation Frequency			32.768	50	kHz
f(Ring)	On-chip Oscillation Frequency		0.5	1	2	MHz
f(PLL)	PLL Clock Oscillation Frequency (2)	VCC1=3.0V to 5.5V	10		24	MHz
		VCC1=2.7V to 3.0V	10		46.67×VCC1 -116	MHz
f(BCLK)	CPU Operation Clock		0		24	MHz
tsu(PLL)	PLL Frequency Synthesizer Stabilization Wait Time	VCC1=5.5V			20	ms
		VCC1=3.0V			50	ms

NOTES:

1. Referenced to VCC1 = VCC2 = 2.7 to 5.5V at Topr = -20 to 85°C / -40 to 85°C unless otherwise specified.
2. Relationship between main clock oscillation frequency, and supply voltage.

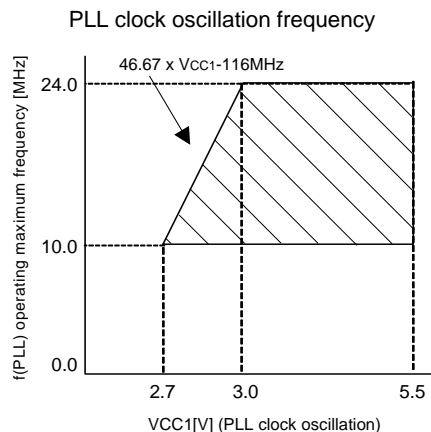
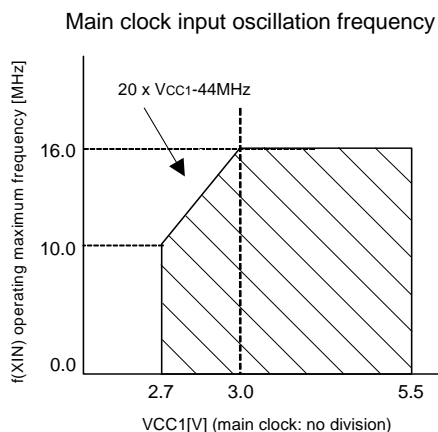


Table 5.4 A/D Conversion Characteristics (1)

Symbol	Parameter		Measuring Condition	Standard			Unit
				Min.	Typ.	Max.	
–	Resolution		$V_{REF}=V_{CC1}$			10	Bits
INL	Integral Non-Linearity Error	10bit	$V_{REF}=V_{CC1}=5V$ AN0 to AN7 input, AN0_0 to AN0_7 input, AN2_0 to AN2_7 input, ANEX0, ANEX1 input			± 3	LSB
			External operation amp connection mode			± 7	LSB
		$V_{REF}=V_{CC1}=3.3V$ AN0 to AN7 input, AN0_0 to AN0_7 input, AN2_0 to AN2_7 input, ANEX0, ANEX1 input			± 5	LSB	
		External operation amp connection mode			± 7	LSB	
		8bit	$V_{REF}=V_{CC1}=5V, 3.3V$			± 2	LSB
–	Absolute Accuracy	10bit	$V_{REF}=V_{CC1}=5V$ AN0 to AN7 input, AN0_0 to AN0_7 input, AN2_0 to AN2_7 input, ANEX0, ANEX1 input			± 3	LSB
			External operation amp connection mode			± 7	LSB
		$V_{REF}=V_{CC1}=3.3V$ AN0 to AN7 input, AN0_0 to AN0_7 input, AN2_0 to AN2_7 input, ANEX0, ANEX1 input			± 5	LSB	
		External operation amp connection mode			± 7	LSB	
		8bit	$V_{REF}=V_{CC1}=5V, 3.3V$			± 2	LSB
–	Tolerance Level Impedance				3		$k\Omega$
DNL	Differential Non-Linearity Error					± 1	LSB
–	Offset Error					± 3	LSB
–	Gain Error					± 3	LSB
RLADDER	Ladder Resistance		$V_{REF}=V_{CC1}$	10		40	$k\Omega$
tCONV	10-bit Conversion Time, Sample & Hold Available		$V_{REF}=V_{CC1}=5V, \phi_{AD}=12MHz$	2.75			μs
tCONV	8-bit Conversion Time, Sample & Hold Available		$V_{REF}=V_{CC1}=5V, \phi_{AD}=12MHz$	2.33			μs
tsAMP	Sampling Time			0.25			μs
VREF	Reference Voltage			2.0		V_{CC1}	V
VIA	Analog Input Voltage			0		V_{REF}	V

NOTES:

1. Referenced to $V_{CC1}=AV_{CC}=V_{REF}=3.3$ to $5.5V$, $V_{SS}=AV_{SS}=0V$ at $T_{opr} = -20$ to $85^{\circ}C / -40$ to $85^{\circ}C$ unless otherwise specified.
2. If $V_{CC1} > V_{CC2}$, do not use AN0_0 to AN0_7 and AN2_0 to AN2_7 as analog input pins.
3. ϕ_{AD} frequency must be 12 MHz or less. And divide the fAD if V_{CC1} is less than 4.0V, and ϕ_{AD} frequency into 10 MHz or less.
4. When sample & hold is disabled, ϕ_{AD} frequency must be 250 kHz or more, in addition to the limitation in Note 3.
When sample & hold is enabled, ϕ_{AD} frequency must be 1MHz or more, in addition to the limitation in Note 3.

Table 5.5 D/A Conversion Characteristics (1)

Symbol	Parameter	Measuring Condition	Standard			Unit
			Min.	Typ.	Max.	
–	Resolution				8	Bits
–	Absolute Accuracy				1.0	%
tsu	Setup Time				3	μs
Ro	Output Resistance		4	10	20	kΩ
IvREF	Reference Power Supply Input Current	(NOTE 2)			1.5	mA

NOTES:

1. Referenced to $V_{CC1}=V_{REF}=3.3$ to $5.5V$, $V_{SS}=AV_{SS}=0V$ at $T_{opr} = -20$ to $85^{\circ}C / -40$ to $85^{\circ}C$ unless otherwise specified.
2. This applies when using one D/A converter, with the D/A register for the unused D/A converter set to "00h". The resistor ladder of the A/D converter is not included. Also, when D/A register contents are not "00h", the IvREF will flow even if Vref id disconnected by the A/D control register.

Table 5.6 Flash Memory Version Electrical Characteristics ⁽¹⁾ for 100 cycle products (D3, D5, U3, U5)

Symbol	Parameter		Standard			Unit
			Min.	Typ.	Max.	
–	Program and Erase Endurance ⁽³⁾		100			cycle
–	Word Program Time (V _{CC1} =5.0V)			25	200	μs
–	Lock Bit Program Time			25	200	μs
–	Block Erase Time (V _{CC1} =5.0V)	4-Kbyte block		0.3	4	s
–		8-Kbyte block		0.3	4	s
–		32-Kbyte block		0.5	4	s
–		64-Kbyte block		0.8	4	s
–	Erase All Unlocked Blocks Time ⁽²⁾				4xn	s
tps	Flash Memory Circuit Stabilization Wait Time				15	μs
–	Data Hold Time ⁽⁵⁾		10			year

Table 5.7 Flash Memory Version Electrical Characteristics ⁽⁶⁾ for 10,000 cycle products (D7, D9, U7, U9) (Block A and Block 1 ⁽⁷⁾)

Symbol	Parameter		Standard			Unit
			Min.	Typ.	Max.	
–	Program and Erase Endurance ^(3, 8, 9)		10,000 ⁽⁴⁾			cycle
–	Word Program Time (V _{CC1} =5.0V)			25		μs
–	Lock Bit Program Time			25		μs
–	Block Erase Time (V _{CC1} =5.0V)	4-Kbyte block		0.3		s
tps		Flash Memory Circuit Stabilization Wait Time				15
–	Data Hold Time ⁽⁵⁾		10			year

NOTES:

1. Referenced to V_{CC1}=4.5 to 5.5V, 3.0 to 3.6V at T_{opr} = 0 to 60 °C (D3, D5, U3, U5) unless otherwise specified.
2. n denotes the number of block erases.
3. Program and Erase Endurance refers to the number of times a block erase can be performed.
If the program and erase endurance is n (n=100, 1,000, or 10,000), each block can be erased n times.
For example, if a 4 Kbytes block A is erased after writing 1 word data 2,048 times, each to a different address, this counts as one program and erase endurance. Data cannot be written to the same address more than once without erasing the block. (Rewrite prohibited)
4. Maximum number of E/W cycles for which operation is guaranteed.
5. T_{opr} = -40 to 85 °C (D3, D7, U3, U7) / -20 to 85 °C (D5, D9, U5, U9).
6. Referenced to V_{CC1} = 4.5 to 5.5V, 3.0 to 3.6V at T_{opr} = -40 to 85 °C (D7, U7) / -20 to 85 °C (D9, U9) unless otherwise specified.
7. Table 5.7 applies for block A or block 1 program and erase endurance > 1,000. Otherwise, use Table 5.6.
8. To reduce the number of program and erase endurance when working with systems requiring numerous rewrites, write to unused word addresses within the block instead of rewrite. Erase block only after all possible addresses are used. For example, an 8-word program can be written 256 times maximum before erase becomes necessary.
Maintaining an equal number of erasure between block A and block 1 will also improve efficiency. It is important to track the total number of times erasure is used.
9. Should erase error occur during block erase, attempt to execute clear status register command, then block erase command at least three times until erase error disappears.
10. Set the PM17 bit in the PM1 register to "1" (wait state) when executing more than 100 times rewrites (D7, D9, U7 and U9).
11. Customers desiring E/W failure rate information should contact their Renesas technical support representative.

Table 5.8 Flash Memory Version Program / Erase Voltage and Read Operation Voltage Characteristics (at T_{opr} = 0 to 60 °C(D3, D5, U3, U5), T_{opr} = -40 to 85 °C(D7, U7) / T_{opr} = -20 to 85 °C(D9, U9))

Flash Program, Erase Voltage	Flash Read Operation Voltage
V _{CC1} = 3.3 V ± 0.3 V or 5.0 V ± 0.5 V	V _{CC1} =2.7 to 5.5 V

Table 5.9 Low Voltage Detection Circuit Electrical Characteristics

Symbol	Parameter	Measuring Condition	Standard			Unit
			Min.	Typ.	Max.	
V _{det4}	Low Voltage Detection Voltage ⁽¹⁾	V _{CC1} =0.8V to 5.5V	3.3	3.8	4.4	V
V _{det3}	Reset Level Detection Voltage ^(1, 2)		2.2	2.8	3.6	V
V _{det4} -V _{det3}	Electric potential difference of Low Voltage Detection and Reset Level Detection		0.3			V
V _{det3s}	Low Voltage Reset Retention Voltage				0.8	V
V _{det3r}	Low Voltage Reset Release Voltage ⁽³⁾		2.2	2.9	4.0	V

NOTES:

1. V_{det4} > V_{det3}.
2. Where reset level detection voltage is less than 2.7 V, if the supply power voltage is greater than the reset level detection voltage, the microcomputer operates with f(BCLK) ≤ 10MHz.
3. V_{det3r} > V_{det3} is not guaranteed.
4. The voltage detection circuit is designed to use when V_{CC1} is set to 5V.

Table 5.10 Power Supply Circuit Timing Characteristics

Symbol	Parameter	Measuring Condition	Standard			Unit
			Min.	Typ.	Max.	
t _d (P-R)	Time for Internal Power Supply Stabilization During Powering-On	V _{CC1} =2.7V to 5.5V			2	ms
t _d (R-S)	STOP Release Time				150	μs
t _d (W-S)	Low Power Dissipation Mode Wait Mode Release Time				150	μs
t _d (S-R)	Brown-out Detection Reset (Hardware Reset 2) Release Wait Time	V _{CC1} =V _{det3r} to 5.5V		6 ⁽¹⁾	20	ms
t _d (E-A)	Low Voltage Detection Circuit Operation Start Time	V _{CC1} =2.7V to 5.5V			20	μs

NOTES:

1. When V_{CC1} = 5V.



Figure 5.1 Power Supply Circuit Timing Diagram

$$V_{CC1}=V_{CC2}=5V$$

Table 5.11 Electrical Characteristics (1) (1)

Symbol	Parameter		Measuring Condition	Standard			Unit
				Min.	Typ.	Max.	
VOH	HIGH Output Voltage (3)	P6_0 to P6_7, P7_2 to P7_7, P8_0 to P8_4, P8_6, P8_7, P9_0 to P9_7, P10_0 to P10_7, P11_0 to P11_7, P14_0, P14_1	IOH=-5mA	VCC1-2.0		VCC1	V
		P0_0 to P0_7, P1_0 to P1_7, P2_0 to P2_7, P3_0 to P3_7, P4_0 to P4_7, P5_0 to P5_7, P12_0 to P12_7, P13_0 to P13_7	IOH=-5mA (2)	VCC2-2.0		VCC2	
VOH	HIGH Output Voltage (3)	P6_0 to P6_7, P7_2 to P7_7, P8_0 to P8_4, P8_6, P8_7, P9_0 to P9_7, P10_0 to P10_7, P11_0 to P11_7, P14_0, P14_1	OH=-200μA	VCC1-0.3		VCC1	V
		P0_0 to P0_7, P1_0 to P1_7, P2_0 to P2_7, P3_0 to P3_7, P4_0 to P4_7, P5_0 to P5_7, P12_0 to P12_7, P13_0 to P13_7	IOH=-200μA (2)	VCC2-0.3		VCC2	
VOH	HIGH Output Voltage XOUT	HIGHPOWER	IOH=-1mA	VCC1-2.0		VCC1	V
			LOWPOWER	IOH=-0.5mA	VCC1-2.0		
	HIGH Output Voltage XCOUT	HIGHPOWER	With no load applied		2.5		V
			LOWPOWER	With no load applied		1.6	
VOL	LOW Output Voltage (3)	P6_0 to P6_7, P7_0 to P7_7, P8_0 to P8_4, P8_6, P8_7, P9_0 to P9_7, P10_0 to P10_7, P11_0 to P11_7, P14_0, P14_1	IOL=5mA			2.0	V
		P0_0 to P0_7, P1_0 to P1_7, P2_0 to P2_7, P3_0 to P3_7, P4_0 to P4_7, P5_0 to P5_7, P12_0 to P12_7, P13_0 to P13_7	IOL=5mA (2)			2.0	
VOL	LOW Output Voltage (3)	P6_0 to P6_7, P7_0 to P7_7, P8_0 to P8_4, P8_6, P8_7, P9_0 to P9_7, P10_0 to P10_7, P11_0 to P11_7, P14_0, P14_1	IOL=200μA			0.45	V
		P0_0 to P0_7, P1_0 to P1_7, P2_0 to P2_7, P3_0 to P3_7, P4_0 to P4_7, P5_0 to P5_7, P12_0 to P12_7, P13_0 to P13_7	IOL=200μA (2)			0.45	
VOL	LOW Output Voltage XOUT	HIGHPOWER	IOL=1mA			2.0	V
			LOWPOWER	IOL=0.5mA			
	LOW Output Voltage XCOUT	HIGHPOWER	With no load applied		0		V
			LOWPOWER	With no load applied		0	
VT+-VT-	Hysteresis	HOLD, RDY, TA0IN to TA4IN, TB0IN to TB5IN, INT0 to INT5, NMI, ADTRG, CTS0 to CTS2, CLK0 to CLK4, TA0OUT to TA4OUT, KI0 to KI3, RXD0 to RXD2, SCL0 to SCL2, SDA0 to SDA2, SIN3, SIN4		0.2		1.0	V
VT+-VT-	Hysteresis	RESET		0.2		2.5	V
I _{IH}	HIGH Input Current (3)	P0_0 to P0_7, P1_0 to P1_7, P2_0 to P2_7, P3_0 to P3_7, P4_0 to P4_7, P5_0 to P5_7, P6_0 to P6_7, P7_0 to P7_7, P8_0 to P8_7, P9_0 to P9_7, P10_0 to P10_7, P11_0 to P11_7, P12_0 to P12_7, P13_0 to P13_7, P14_0, P14_1, XIN, RESET, CNVSS, BYTE	Vi=5V			5.0	μA
I _{IL}	LOW Input Current (3)	P0_0 to P0_7, P1_0 to P1_7, P2_0 to P2_7, P3_0 to P3_7, P4_0 to P4_7, P5_0 to P5_7, P6_0 to P6_7, P7_0 to P7_7, P8_0 to P8_7, P9_0 to P9_7, P10_0 to P10_7, P11_0 to P11_7, P12_0 to P12_7, P13_0 to P13_7, P14_0, P14_1, XIN, RESET, CNVSS, BYTE	Vi=0V			-5.0	μA
RPULLUP	Pull-Up Resistance (3)	P0_0 to P0_7, P1_0 to P1_7, P2_0 to P2_7, P3_0 to P3_7, P4_0 to P4_7, P5_0 to P5_7, P6_0 to P6_7, P7_2 to P7_7, P8_0 to P8_4, P8_6, P8_7, P9_0 to P9_7, P10_0 to P10_7, P11_0 to P11_7, P12_0 to P12_7, P13_0 to P13_7, P14_0, P14_1	Vi=0V	30	50	170	kΩ
R _{XIN}	Feedback Resistance	XIN			1.5		MΩ
R _{XCIN}	Feedback Resistance	XCIN			15		MΩ
V _{RAM}	RAM Retention Voltage		At stop mode	2.0			V

NOTES:

1. Referenced to VCC1=VCC2=4.2 to 5.5V, VSS = 0V at T_{opr} = -20 to 85°C / -40 to 85°C, f(BCLK)=24MHz unless otherwise specified.
2. Where the product is used at VCC1 = 5 V and VCC2 = 3 V, refer to the 3 V version value for the pin specified value on VCC2 port side.
3. There is no external connections for port P1_0 to P1_7, P4_4 to P4_7, P7_2 to P7_5 and P9_1 in 80-pin version.

Table 5.12 Electrical Characteristics (2) (1)

Symbol	Parameter		Measuring Condition		Standard			Unit
					Min.	Typ.	Max.	
I _{cc}	Power Supply Current (V _{CC1} =V _{CC2} =4.0V to 5.5V)	In single-chip mode, the output pins are open and other pins are V _{SS}	Mask ROM	f(BCLK)=24MHz No division, PLL operation		14	20	mA
				No division, On-chip oscillation		1		mA
			Flash Memory	f(BCLK)=24MHz, No division, PLL operation		18	27	mA
				No division, On-chip oscillation		1.8		mA
			Flash Memory Program	f(BCLK)=10MHz, VCC1=5.0V		15		mA
			Flash Memory Erase	f(BCLK)=10MHz, VCC1=5.0V		25		mA
			Mask ROM	f(XCIN)=32kHz Low power dissipation mode, ROM (3)		25		μA
			Flash Memory	f(BCLK)=32kHz Low power dissipation mode, RAM (3)		25		μA
				f(BCLK)=32kHz Low power dissipation mode, Flash Memory (3)		420		μA
				On-chip oscillation, Wait mode		50		μA
			Mask ROM Flash Memory	f(BCLK)=32kHz Wait mode (2), Oscillation capability High		7.5		μA
f(BCLK)=32kHz Wait mode (2), Oscillation capability Low		2.0			μA			
Stop mode T _{opr} =25°C		0.8		3.0	μA			
I _{det4}	Low Voltage Detection Dissipation Current (4)				0.7	4	μA	
I _{det3}	Reset Area Detection Dissipation Current (4)				1.2	8	μA	

NOTES:

1. Referenced to V_{CC1}=V_{CC2}=4.2 to 5.5V, V_{SS} = 0V at T_{opr} = -20 to 85°C / -40 to 85°C, f(BCLK)=24MHz unless otherwise specified.
2. With one timer operated using fC32.
3. This indicates the memory in which the program to be executed exists.
4. I_{det} is dissipation current when the following bit is set to "1" (detection circuit enabled).
I_{det4}: VC27 bit in the VCR2 register
I_{det3}: VC26 bit in the VCR2 register

$$V_{CC1}=V_{CC2}=5V$$

Timing Requirements

($V_{CC1} = V_{CC2} = 5V$, $V_{SS} = 0V$, at $T_{opr} = -20$ to $85^{\circ}C$ / -40 to $85^{\circ}C$ unless otherwise specified)

Table 5.13 External Clock Input (XIN input) (1)

Symbol	Parameter	Standard		Unit
		Min.	Max.	
t_c	External Clock Input Cycle Time	62.5		ns
$t_{w(H)}$	External Clock Input HIGH Pulse Width	25		ns
$t_{w(L)}$	External Clock Input LOW Pulse Width	25		ns
t_r	External Clock Rise Time		15	ns
t_f	External Clock Fall Time		15	ns

NOTES:

1. The condition is $V_{CC1}=V_{CC2}=3.0$ to $5.0V$.

Table 5.14 Memory Expansion Mode and Microprocessor Mode

Symbol	Parameter	Standard		Unit
		Min.	Max.	
$t_{ac1(RD-DB)}$	Data Input Access Time (for setting with no wait)		(NOTE 1)	ns
$t_{ac2(RD-DB)}$	Data Input Access Time (for setting with wait)		(NOTE 2)	ns
$t_{ac3(RD-DB)}$	Data Input Access Time (when accessing multiplex bus area)		(NOTE 3)	ns
$t_{su(DB-RD)}$	Data Input Setup Time	40		ns
$t_{su(RDY-BCLK)}$	RDY Input Setup Time	30		ns
$t_{su(HOLD-BCLK)}$	HOLD Input Setup Time	40		ns
$t_h(RD-DB)$	Data Input Hold Time	0		ns
$t_h(BCLK-RDY)$	RDY Input Hold Time	0		ns
$t_h(BCLK-HOLD)$	HOLD Input Hold Time	0		ns

NOTES:

1. Calculated according to the BCLK frequency as follows:

$$\frac{0.5 \times 10^9}{f(BCLK)} - 45 [ns]$$

2. Calculated according to the BCLK frequency as follows:

$$\frac{(n-0.5) \times 10^9}{f(BCLK)} - 45 [ns] \quad n \text{ is "2" for 1-wait setting, "3" for 2-wait setting and "4" for 3-wait setting.}$$

3. Calculated according to the BCLK frequency as follows:

$$\frac{(n-0.5) \times 10^9}{f(BCLK)} - 45 [ns] \quad n \text{ is "2" for 2-wait setting, "3" for 3-wait setting.}$$

$$V_{CC1}=V_{CC2}=5V$$

Timing Requirements(V_{CC1} = V_{CC2} = 5V, V_{SS} = 0V, at T_{opr} = -20 to 85°C / -40 to 85°C unless otherwise specified)**Table 5.15 Timer A Input (Counter Input in Event Counter Mode)**

Symbol	Parameter	Standard		Unit
		Min.	Max.	
t _{c(TA)}	TAiIN Input Cycle Time	100		ns
t _{w(TAH)}	TAiIN Input HIGH Pulse Width	40		ns
t _{w(TAL)}	TAiIN Input LOW Pulse Width	40		ns

Table 5.16 Timer A Input (Gating Input in Timer Mode)

Symbol	Parameter	Standard		Unit
		Min.	Max.	
t _{c(TA)}	TAiIN Input Cycle Time	400		ns
t _{w(TAH)}	TAiIN Input HIGH Pulse Width	200		ns
t _{w(TAL)}	TAiIN Input LOW Pulse Width	200		ns

Table 5.17 Timer A Input (External Trigger Input in One-shot Timer Mode)

Symbol	Parameter	Standard		Unit
		Min.	Max.	
t _{c(TA)}	TAiIN Input Cycle Time	200		ns
t _{w(TAH)}	TAiIN Input HIGH Pulse Width	100		ns
t _{w(TAL)}	TAiIN Input LOW Pulse Width	100		ns

Table 5.18 Timer A Input (External Trigger Input in Pulse Width Modulation Mode)

Symbol	Parameter	Standard		Unit
		Min.	Max.	
t _{w(TAH)}	TAiIN Input HIGH Pulse Width	100		ns
t _{w(TAL)}	TAiIN Input LOW Pulse Width	100		ns

Table 5.19 Timer A Input (Counter Increment/Decrement Input in Event Counter Mode)

Symbol	Parameter	Standard		Unit
		Min.	Max.	
t _{c(UP)}	TAiOUT Input Cycle Time	2000		ns
t _{w(UPH)}	TAiOUT Input HIGH Pulse Width	1000		ns
t _{w(UPL)}	TAiOUT Input LOW Pulse Width	1000		ns
t _{su(UP-TIN)}	TAiOUT Input Setup Time	400		ns
t _{h(TIN-UP)}	TAiOUT Input Hold Time	400		ns

Table 5.20 Timer A Input (Two-phase Pulse Input in Event Counter Mode)

Symbol	Parameter	Standard		Unit
		Min.	Max.	
t _{c(TA)}	TAiIN Input Cycle Time	800		ns
t _{su(TAIN-TAOUT)}	TAiOUT Input Setup Time	200		ns
t _{su(TAOUT-TAIN)}	TAiIN Input Setup Time	200		ns

$$V_{CC1}=V_{CC2}=5V$$

Timing Requirements

($V_{CC1} = V_{CC2} = 5V$, $V_{SS} = 0V$, at $T_{opr} = -20$ to $85^{\circ}C$ / -40 to $85^{\circ}C$ unless otherwise specified)

Table 5.21 Timer B Input (Counter Input in Event Counter Mode)

Symbol	Parameter	Standard		Unit
		Min.	Max.	
$t_{c(TB)}$	TBiIN Input Cycle Time (counted on one edge)	100		ns
$t_{w(TBH)}$	TBiIN Input HIGH Pulse Width (counted on one edge)	40		ns
$t_{w(TBL)}$	TBiIN Input LOW Pulse Width (counted on one edge)	40		ns
$t_{c(TB)}$	TBiIN Input Cycle Time (counted on both edges)	200		ns
$t_{w(TBH)}$	TBiIN Input HIGH Pulse Width (counted on both edges)	80		ns
$t_{w(TBL)}$	TBiIN Input LOW Pulse Width (counted on both edges)	80		ns

Table 5.22 Timer B Input (Pulse Period Measurement Mode)

Symbol	Parameter	Standard		Unit
		Min.	Max.	
$t_{c(TB)}$	TBiIN Input Cycle Time	400		ns
$t_{w(TBH)}$	TBiIN Input HIGH Pulse Width	200		ns
$t_{w(TBL)}$	TBiIN Input LOW Pulse Width	200		ns

Table 5.23 Timer B Input (Pulse Width Measurement Mode)

Symbol	Parameter	Standard		Unit
		Min.	Max.	
$t_{c(TB)}$	TBiIN Input Cycle Time	400		ns
$t_{w(TBH)}$	TBiIN Input HIGH Pulse Width	200		ns
$t_{w(TBL)}$	TBiIN Input LOW Pulse Width	200		ns

Table 5.24 A/D Trigger Input

Symbol	Parameter	Standard		Unit
		Min.	Max.	
$t_{c(AD)}$	\overline{ADTRG} Input Cycle Time	1000		ns
$t_{w(ADL)}$	\overline{ADTRG} input LOW Pulse Width	125		ns

Table 5.25 Serial Interface

Symbol	Parameter	Standard		Unit
		Min.	Max.	
$t_{c(CK)}$	CLKi Input Cycle Time	200		ns
$t_{w(CKH)}$	CLKi Input HIGH Pulse Width	100		ns
$t_{w(CKL)}$	CLKi Input LOW Pulse Width	100		ns
$t_{d(C-Q)}$	TXDi Output Delay Time		80	ns
$t_{h(C-Q)}$	TXDi Hold Time	0		ns
$t_{su(D-C)}$	RXD _i Input Setup Time	70		ns
$t_{h(C-D)}$	RXD _i Input Hold Time	90		ns

Table 5.26 External Interrupt \overline{INTi} Input

Symbol	Parameter	Standard		Unit
		Min.	Max.	
$t_{w(INH)}$	\overline{INTi} Input HIGH Pulse Width	250		ns
$t_{w(INL)}$	\overline{INTi} Input LOW Pulse Width	250		ns

$$V_{CC1} = V_{CC2} = 5V$$

Switching Characteristics

(V_{CC1} = V_{CC2} = 5V, V_{SS} = 0V, at T_{opr} = -20 to 85°C / -40 to 85°C unless otherwise specified)

Table 5.27 Memory Expansion and Microprocessor Modes (for setting with no wait)

Symbol	Parameter	Standard		Unit
		Min.	Max.	
t _d (BCLK-AD)	Address Output Delay Time		25	ns
t _h (BCLK-AD)	Address Output Hold Time (in relation to BCLK)	4		ns
t _h (RD-AD)	Address Output Hold Time (in relation to RD)	0		ns
t _h (WR-AD)	Address Output Hold Time (in relation to WR)	(NOTE 2)		ns
t _d (BCLK-CS)	Chip Select Output Delay Time		25	ns
t _h (BCLK-CS)	Chip Select Output Hold Time (in relation to BCLK)	4		ns
t _d (BCLK-ALE)	ALE Signal Output Delay Time		15	ns
t _h (BCLK-ALE)	ALE Signal Output Hold Time	-4		ns
t _d (BCLK-RD)	RD Signal Output Delay Time		25	ns
t _h (BCLK-RD)	RD Signal Output Hold Time	0		ns
t _d (BCLK-WR)	WR Signal Output Delay Time		25	ns
t _h (BCLK-WR)	WR Signal Output Hold Time	0		ns
t _d (BCLK-DB)	Data Output Delay Time (in relation to BCLK)		40	ns
t _h (BCLK-DB)	Data Output Hold Time (in relation to BCLK) ⁽³⁾	4		ns
t _d (DB-WR)	Data Output Delay Time (in relation to WR)	(NOTE 1)		ns
t _h (WR-DB)	Data Output Hold Time (in relation to WR) ⁽³⁾	(NOTE 2)		ns
t _d (BCLK-HLDA)	HLDA Output Delay Time		40	ns

See Figure 5.2

NOTES:

1. Calculated according to the BCLK frequency as follows:

$$\frac{0.5 \times 10^9}{f(\text{BCLK})} - 40[\text{ns}] \quad f(\text{BCLK}) \text{ is } 12.5\text{MHz or less.}$$

2. Calculated according to the BCLK frequency as follows:

$$\frac{0.5 \times 10^9}{f(\text{BCLK})} - 10[\text{ns}]$$

3. This standard value shows the timing when the output is off, and does not show hold time of data bus.

Hold time of data bus varies with capacitor volume and pull-up (pull-down) resistance value.

Hold time of data bus is expressed in

$$t = -CR \times \ln(1 - V_{OL} / V_{CC2})$$

by a circuit of the right figure.

For example, when V_{OL} = 0.2V_{CC2}, C = 30pF, R = 1kΩ, hold time of output "L" level is

$$t = -30\text{pF} \times 1\text{k}\Omega \times \ln(1 - 0.2V_{CC2} / V_{CC2}) = 6.7\text{ns.}$$

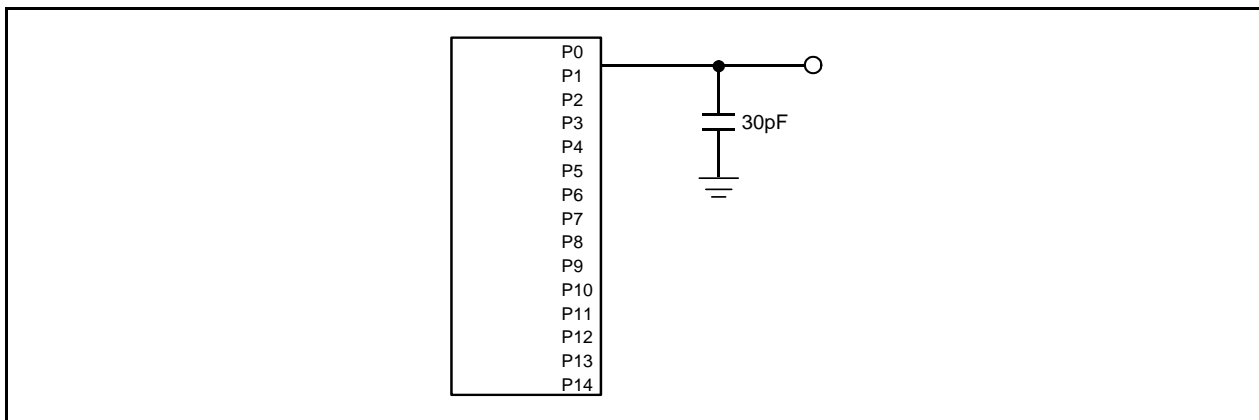
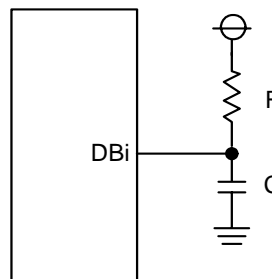


Figure 5.2 Ports P0 to P14 Measurement Circuit

$$V_{CC1}=V_{CC2}=5V$$

Switching Characteristics

($V_{CC1} = V_{CC2} = 5V$, $V_{SS} = 0V$, at $T_{opr} = -20$ to $85^{\circ}C$ / -40 to $85^{\circ}C$ unless otherwise specified)

Table 5.28 Memory Expansion and Microprocessor Modes (for 1- to 3-wait setting and external area access)

Symbol	Parameter		Standard		Unit
			Min.	Max.	
$t_{d(BCLK-AD)}$	Address Output Delay Time	See Figure 5.2		25	ns
$t_{h(BCLK-AD)}$	Address Output Hold Time (in relation to BCLK)		4		ns
$t_{h(RD-AD)}$	Address Output Hold Time (in relation to RD)		0		ns
$t_{h(WR-AD)}$	Address Output Hold Time (in relation to WR)		(NOTE 2)		ns
$t_{d(BCLK-CS)}$	Chip Select Output Delay Time			25	ns
$t_{h(BCLK-CS)}$	Chip Select Output Hold Time (in relation to BCLK)		4		ns
$t_{d(BCLK-ALE)}$	ALE Signal Output Delay Time			15	ns
$t_{h(BCLK-ALE)}$	ALE Signal Output Hold Time		-4		ns
$t_{d(BCLK-RD)}$	RD Signal Output Delay Time			25	ns
$t_{h(BCLK-RD)}$	RD Signal Output Hold Time		0		ns
$t_{d(BCLK-WR)}$	WR Signal Output Delay Time			25	ns
$t_{h(BCLK-WR)}$	WR Signal Output Hold Time		0		ns
$t_{d(BCLK-DB)}$	Data Output Delay Time (in relation to BCLK)			40	ns
$t_{h(BCLK-DB)}$	Data Output Hold Time (in relation to BCLK) ⁽³⁾		4		ns
$t_{d(DB-WR)}$	Data Output Delay Time (in relation to WR)		(NOTE 1)		ns
$t_{h(WR-DB)}$	Data Output Hold Time (in relation to WR) ⁽³⁾		(NOTE 2)		ns
$t_{d(BCLK-HLDA)}$	HLDA Output Delay Time		40	ns	

NOTES:

1. Calculated according to the BCLK frequency as follows:

$$\frac{(n-0.5) \times 10^9}{f(\text{BCLK})} - 40[\text{ns}]$$

n is "1" for 1-wait setting, "2" for 2-wait setting and "3" for 3-wait setting.
(BCLK) is 12.5MHz or less.

2. Calculated according to the BCLK frequency as follows:

$$\frac{0.5 \times 10^9}{f(\text{BCLK})} - 10[\text{ns}]$$

3. This standard value shows the timing when the output is off, and does not show hold time of data bus.

Hold time of data bus varies with capacitor volume and pull-up (pull-down) resistance value.

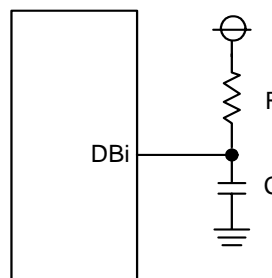
Hold time of data bus is expressed in

$$t = -CR \times \ln(1 - V_{OL} / V_{CC2})$$

by a circuit of the right figure.

For example, when $V_{OL} = 0.2V_{CC2}$, $C = 30\text{pF}$, $R = 1\text{k}\Omega$, hold time of output "L" level is

$$t = -30\text{pF} \times 1\text{k}\Omega \times \ln(1 - 0.2V_{CC2} / V_{CC2}) = 6.7\text{ns}.$$



$$V_{CC1}=V_{CC2}=5V$$

Switching Characteristics

($V_{CC1} = V_{CC2} = 5V$, $V_{SS} = 0V$, at $T_{opr} = -20$ to $85^{\circ}C$ / -40 to $85^{\circ}C$ unless otherwise specified)

Table 5.29 Memory Expansion and Microprocessor Modes (for 2- to 3-wait setting, external area access and multiplex bus selection)

Symbol	Parameter		Standard		Unit
			Min.	Max.	
$t_d(\text{BCLK-AD})$	Address Output Delay Time	See Figure 5.2		25	ns
$t_h(\text{BCLK-AD})$	Address Output Hold Time (in relation to BCLK)		4		ns
$t_h(\text{RD-AD})$	Address Output Hold Time (in relation to RD)		(NOTE 1)		ns
$t_h(\text{WR-AD})$	Address Output Hold Time (in relation to WR)		(NOTE 1)		ns
$t_d(\text{BCLK-CS})$	Chip Select Output Delay Time			25	ns
$t_h(\text{BCLK-CS})$	Chip Select Output Hold Time (in relation to BCLK)		4		ns
$t_h(\text{RD-CS})$	Chip Select Output Hold Time (in relation to RD)		(NOTE 1)		ns
$t_h(\text{WR-CS})$	Chip Select Output Hold Time (in relation to WR)		(NOTE 1)		ns
$t_d(\text{BCLK-RD})$	RD Signal Output Delay Time			25	ns
$t_h(\text{BCLK-RD})$	RD Signal Output Hold Time		0		ns
$t_d(\text{BCLK-WR})$	WR Signal Output Delay Time			25	ns
$t_h(\text{BCLK-WR})$	WR Signal Output Hold Time		0		ns
$t_d(\text{BCLK-DB})$	Data Output Delay Time (in relation to BCLK)			40	ns
$t_h(\text{BCLK-DB})$	Data Output Hold Time (in relation to BCLK)		4		ns
$t_d(\text{DB-WR})$	Data Output Delay Time (in relation to WR)		(NOTE 2)		ns
$t_h(\text{WR-DB})$	Data Output Hold Time (in relation to WR)		(NOTE 1)		ns
$t_d(\text{BCLK-HLDA})$	HLDA Output Delay Time			40	ns
$t_d(\text{BCLK-ALE})$	ALE Signal Output Delay Time (in relation to BCLK)			15	ns
$t_h(\text{BCLK-ALE})$	ALE Signal Output Hold Time (in relation to BCLK)		-4		ns
$t_d(\text{AD-ALE})$	ALE Signal Output Delay Time (in relation to Address)		(NOTE 3)		ns
$t_h(\text{AD-ALE})$	ALE Signal Output Hold Time (in relation to Address)		(NOTE 4)		ns
$t_d(\text{AD-RD})$	RD Signal Output Delay From the End of Address		0		ns
$t_d(\text{AD-WR})$	WR Signal Output Delay From the End of Address		0		ns
$t_{dz}(\text{RD-AD})$	Address Output Floating Start Time			8	ns

NOTES:

1. Calculated according to the BCLK frequency as follows:

$$\frac{0.5 \times 10^9}{f(\text{BCLK})} - 10 [\text{ns}]$$

2. Calculated according to the BCLK frequency as follows:

$$\frac{(n-0.5) \times 10^9}{f(\text{BCLK})} - 40 [\text{ns}] \quad n \text{ is "2" for 2-wait setting, "3" for 3-wait setting.}$$

3. Calculated according to the BCLK frequency as follows:

$$\frac{0.5 \times 10^9}{f(\text{BCLK})} - 25 [\text{ns}]$$

4. Calculated according to the BCLK frequency as follows:

$$\frac{0.5 \times 10^9}{f(\text{BCLK})} - 15 [\text{ns}]$$



Figure 5.3 Timing Diagram (1)

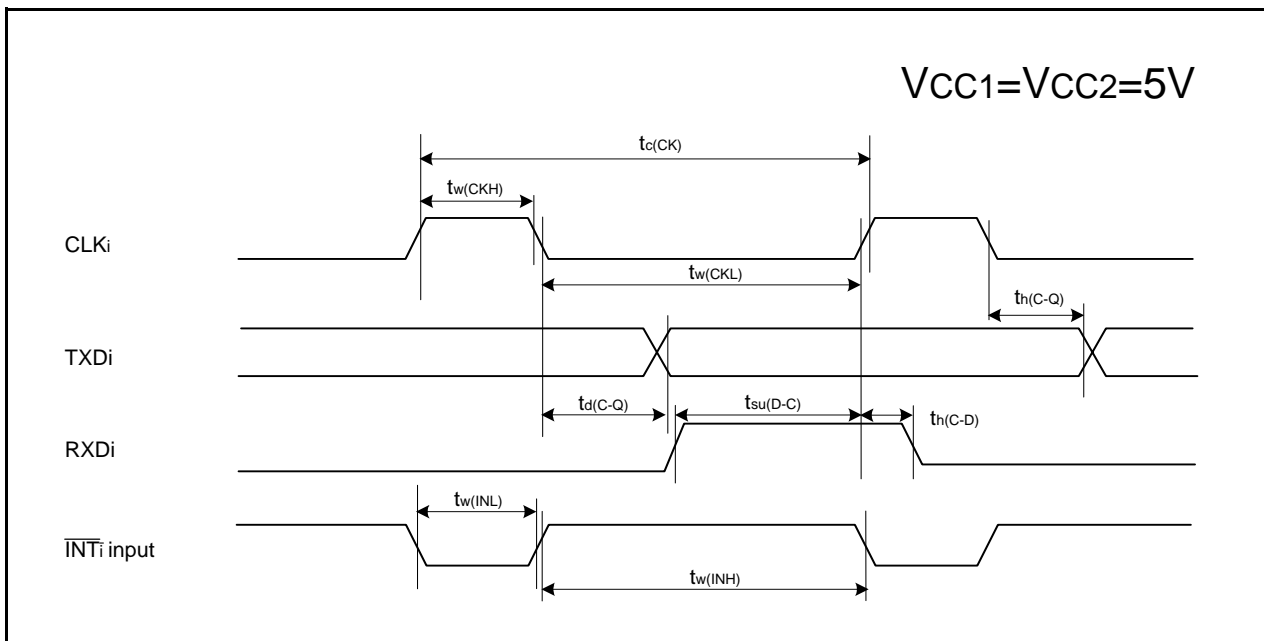
**Figure 5.4** Timing Diagram (2)



Figure 5.5 Timing Diagram (3)

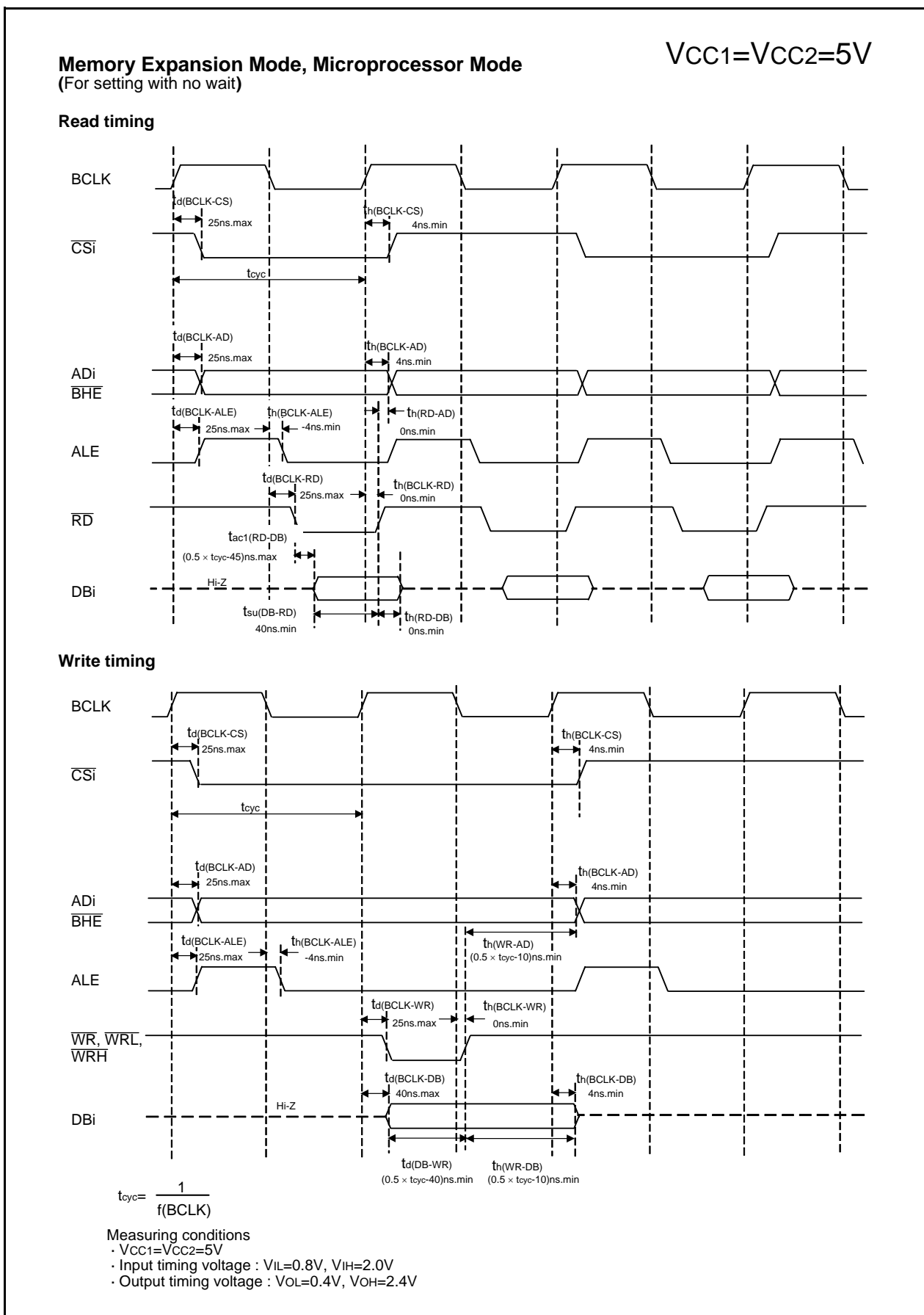


Figure 5.6 Timing Diagram (4)

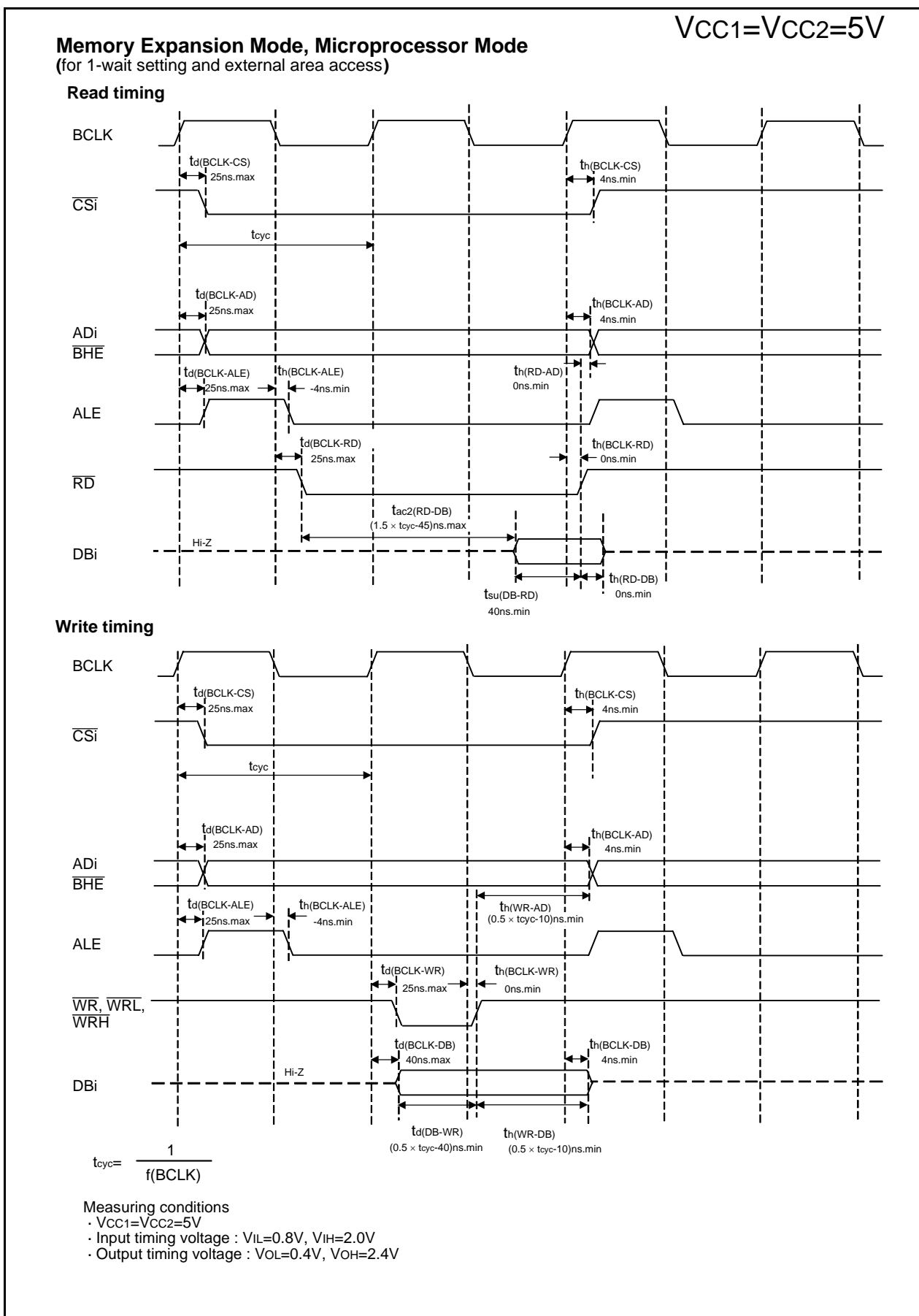


Figure 5.7 Timing Diagram (5)

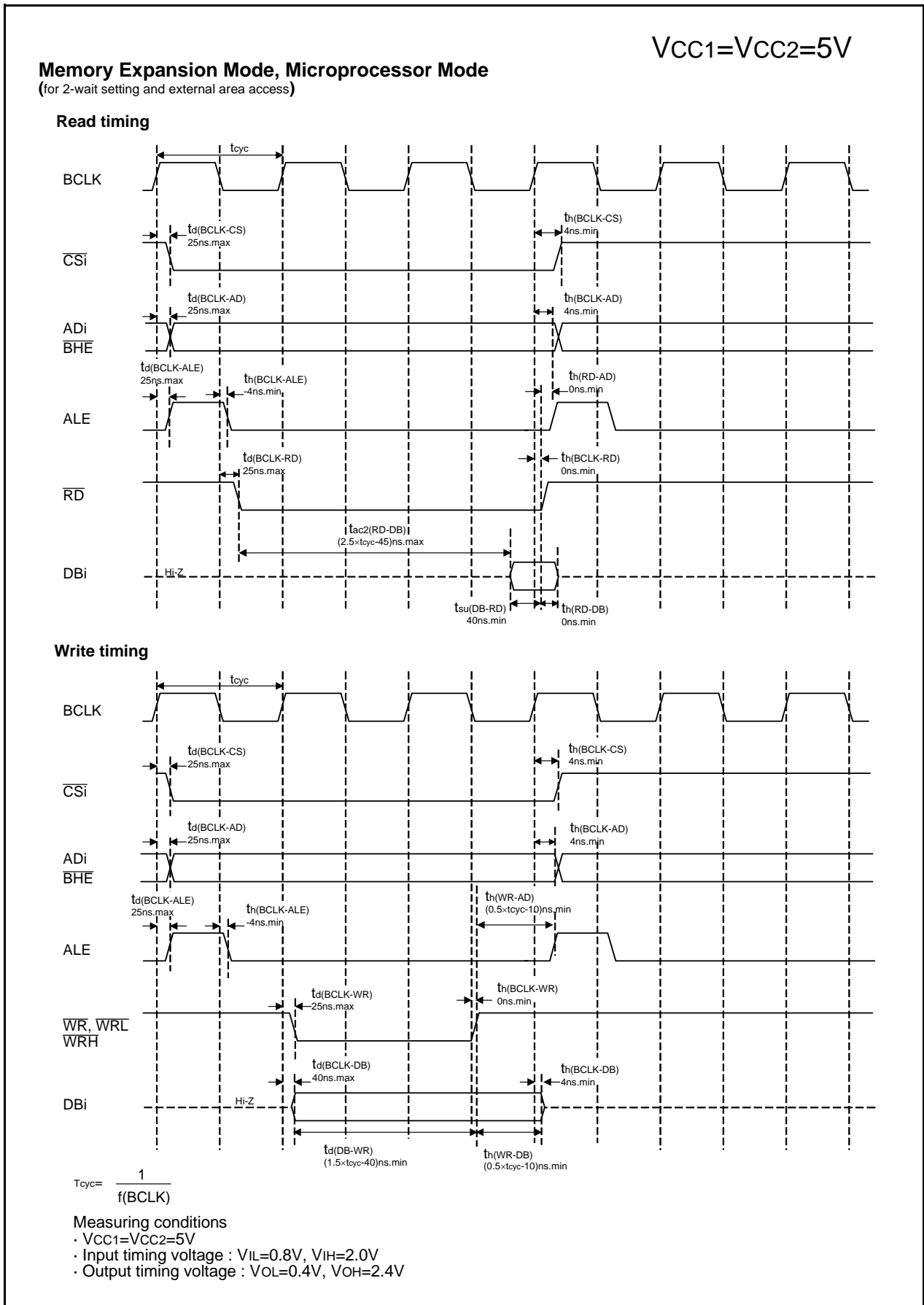


Figure 5.8 Timing Diagram (6)

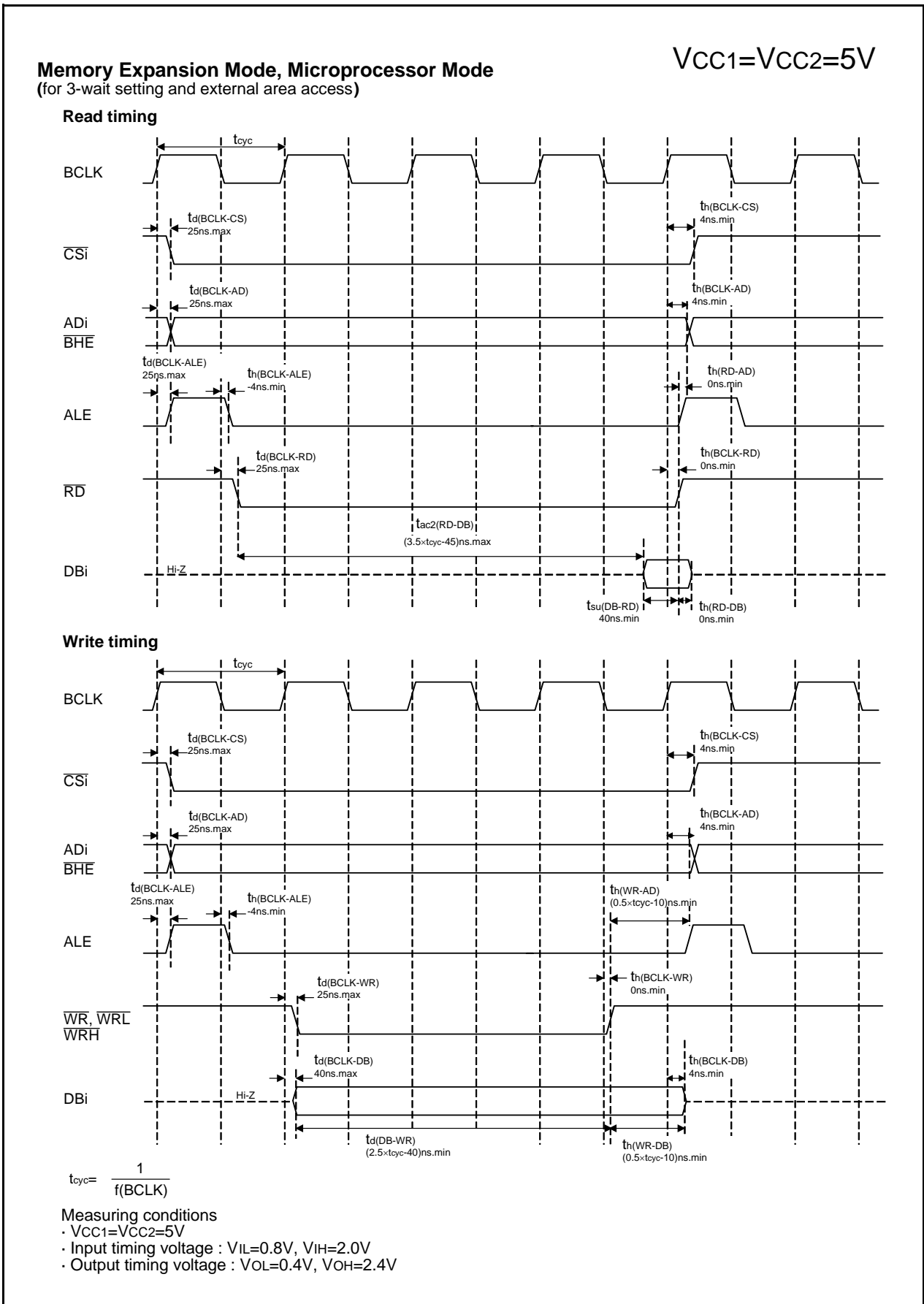


Figure 5.9 Timing Diagram (7)

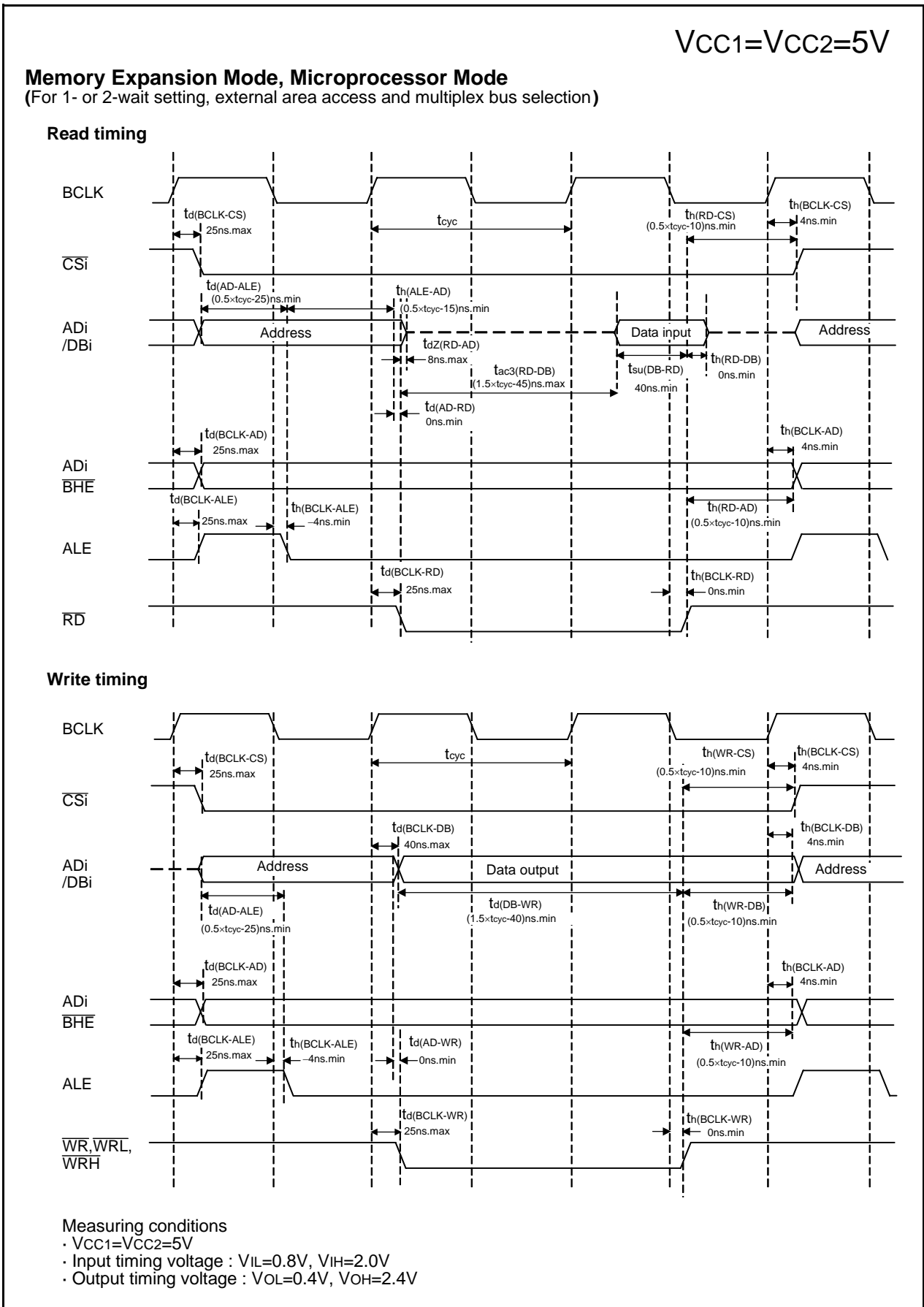


Figure 5.10 Timing Diagram (8)

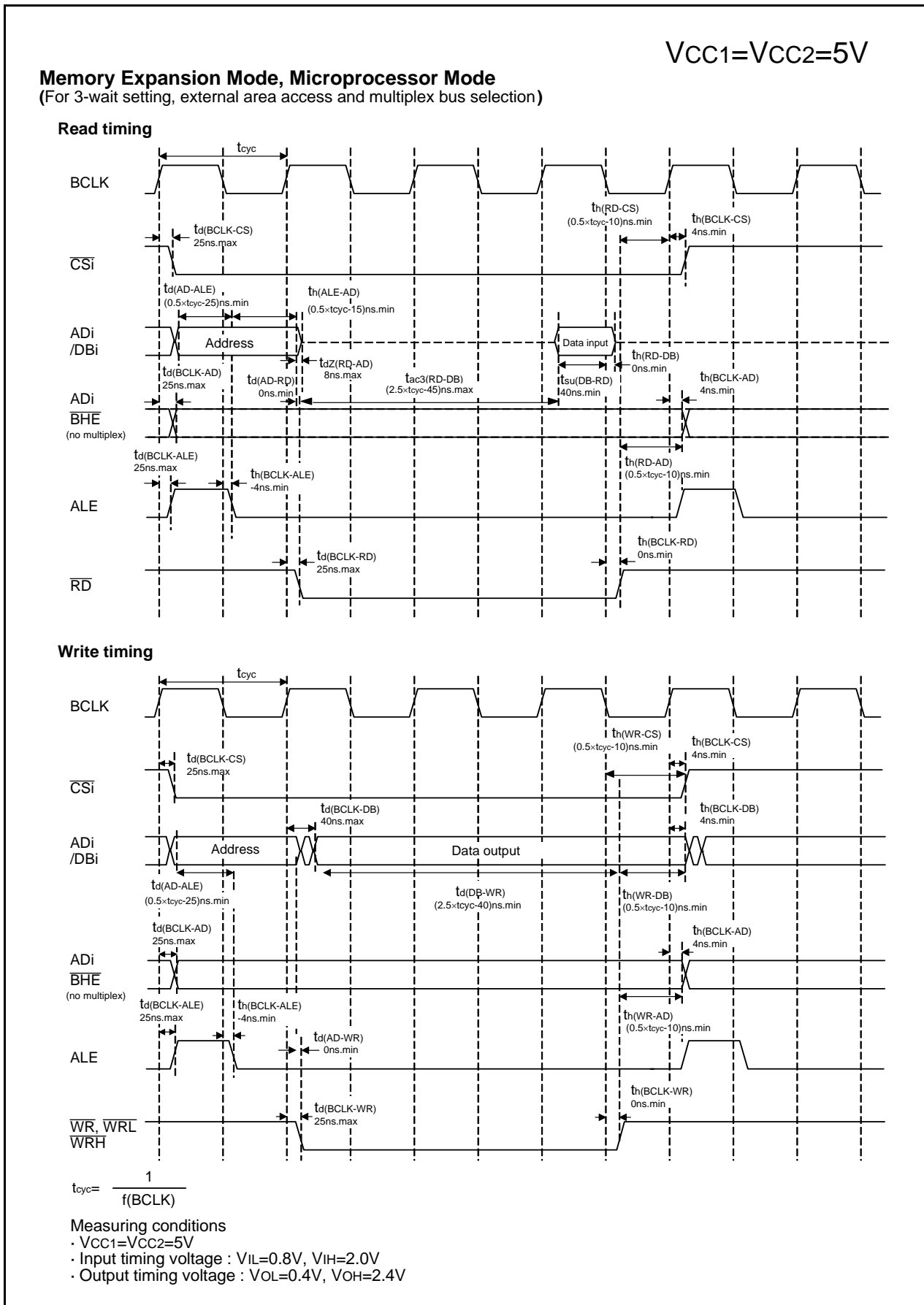


Figure 5.11 Timing Diagram (9)

$$V_{CC1}=V_{CC2}=3V$$

Table 5.30 Electrical Characteristics (1) (1)

Symbol	Parameter		Measuring Condition	Standard			Unit
				Min.	Typ.	Max.	
VOH	HIGH Output Voltage (3)	P6_0 to P6_7, P7_2 to P7_7, P8_0 to P8_4, P8_6, P8_7, P9_0 to P9_7, P10_0 to P10_7, P11_0 to P11_7, P14_0, P14_1	IOH=-1mA	VCC1-0.5		VCC1	V
		P0_0 to P0_7, P1_0 to P1_7, P2_0 to P2_7, P3_0 to P3_7, P4_0 to P4_7, P5_0 to P5_7, P12_0 to P12_7, P13_0 to P13_7	IOH=-1mA (2)	VCC2-0.5		VCC2	
VOH	HIGH Output Voltage XOUT	HIGHPOWER	IOH=-0.1mA	VCC1-0.5		VCC1	V
		LOWPOWER	IOH=-50μA	VCC1-0.5		VCC1	
	HIGH Output Voltage XCOUT	HIGHPOWER	With no load applied		2.5		V
		LOWPOWER	With no load applied		1.6		
VOL	LOW Output Voltage (3)	P6_0 to P6_7, P7_0 to P7_7, P8_0 to P8_4, P8_6, P8_7, P9_0 to P9_7, P10_0 to P10_7, P11_0 to P11_7, P14_0, P14_1	IOL=1mA			0.5	V
		P0_0 to P0_7, P1_0 to P1_7, P2_0 to P2_7, P3_0 to P3_7, P4_0 to P4_7, P5_0 to P5_7, P12_0 to P12_7, P13_0 to P13_7	IOL=1mA (2)			0.5	
VOL	LOW Output Voltage XOUT	HIGHPOWER	IOL=0.1mA			0.5	V
		LOWPOWER	IOL=50μA			0.5	
	LOW Output Voltage XCOUT	HIGHPOWER	With no load applied		0		V
		LOWPOWER	With no load applied		0		
VT+-VT-	Hysteresis	HOLD, RDY, TA0IN to TA4IN, TB0IN to TB5IN, INT0 to INT5, NMI, ADTRG, CTS0 to CTS2, CLK0 to CLK4, TAOOUT to TA4OUT, K10 to K13, RXD0 to RXD2, SCL0 to SCL2, SDA0 to SDA2, SIN3, SIN4		0.2		0.8	V
VT+-VT-	Hysteresis	RESET		0.2	(0.7)	1.8	V
IiH	HIGH Input Current (3)	P0_0 to P0_7, P1_0 to P1_7, P2_0 to P2_7, P3_0 to P3_7, P4_0 to P4_7, P5_0 to P5_7, P6_0 to P6_7, P7_0 to P7_7, P8_0 to P8_7, P9_0 to P9_7, P10_0 to P10_7, P11_0 to P11_7, P12_0 to P12_7, P13_0 to P13_7, P14_0, P14_1, XIN, RESET, CNVSS, BYTE	VI=3V			4.0	μA
IiL	LOW Input Current (3)	P0_0 to P0_7, P1_0 to P1_7, P2_0 to P2_7, P3_0 to P3_7, P4_0 to P4_7, P5_0 to P5_7, P6_0 to P6_7, P7_0 to P7_7, P8_0 to P8_7, P9_0 to P9_7, P10_0 to P10_7, P11_0 to P11_7, P12_0 to P12_7, P13_0 to P13_7, P14_0, P14_1, XIN, RESET, CNVSS, BYTE	VI=0V			-4.0	μA
RPULLUP	Pull-Up Resistance (3)	P0_0 to P0_7, P1_0 to P1_7, P2_0 to P2_7, P3_0 to P3_7, P4_0 to P4_7, P5_0 to P5_7, P6_0 to P6_7, P7_2 to P7_7, P8_0 to P8_4, P8_6, P8_7, P9_0 to P9_7, P10_0 to P10_7, P11_0 to P11_7, P12_0 to P12_7, P13_0 to P13_7, P14_0, P14_1	VI=0V	50	100	500	kΩ
RfXIN	Feedback Resistance	XIN			3.0		MΩ
RfXCIN	Feedback Resistance	XCIN			25		MΩ
V _{RAM}	RAM Retention Voltage		At stop mode	2.0			V

NOTES:

1. Referenced to VCC1 = VCC2 = 2.7 to 3.3V, VSS = 0V at Topr = -20 to 85°C / -40 to 85°C, f(XIN)=10MHz no wait unless otherwise specified.
2. VCC1 for the port P6 to P11 and P14, and VCC2 for the port P0 to P5 and P12 to P13
3. There is no external connections for port P1_0 to P1_7, P4_4 to P4_7, P7_2 to P7_5 and P9_1 in 80-pin version.

Table 5.31 Electrical Characteristics (2) (1)

Symbol	Parameter		Measuring Condition		Standard			Unit
					Min.	Typ.	Max.	
I _{cc}	Power Supply Current (V _{CC1} =V _{CC2} =2.7V to 3.6V)	In single-chip mode, the output pins are open and other pins are V _{SS}	Mask ROM	f(BCLK)=10MHz No division		8	11	mA
				No division, On-chip oscillation		1		mA
			Flash Memory	f(BCLK)=10MHz, No division		8	13	mA
				No division, On-chip oscillation		1.8		mA
			Flash Memory Program	f(BCLK)=10MHz, V _{CC1} =3.0V		12		mA
			Flash Memory Erase	f(BCLK)=10MHz, V _{CC1} =3.0V		22		mA
			Mask ROM	f(XCIN)=32kHz Low power dissipation mode, ROM (3)		25		μA
			Flash Memory	f(BCLK)=32kHz Low power dissipation mode, RAM (3)		25		μA
				f(BCLK)=32kHz Low power dissipation mode, Flash Memory (3)		420		μA
				On-chip oscillation, Wait mode		45		μA
			Mask ROM Flash Memory	f(BCLK)=32kHz Wait mode (2), Oscillation capability High		6.0		μA
				f(BCLK)=32kHz Wait mode (2), Oscillation capability Low		1.8		μA
Stop mode T _{opr} =25°C		0.7		3.0	μA			
I _{det4}	Low Voltage Detection Dissipation Current (4)				0.6	4	μA	
I _{det3}	Reset Area Detection Dissipation Current (4)				0.4	2	μA	

NOTES:

1. Referenced to V_{CC1}=V_{CC2}=2.7 to 3.3V, V_{SS} = 0V at T_{opr} = -20 to 85°C / -40 to 85°C, f(BCLK)=10MHz unless otherwise specified.
2. With one timer operated using fC32.
3. This indicates the memory in which the program to be executed exists.
4. I_{det} is dissipation current when the following bit is set to "1" (detection circuit enabled).
I_{det4}: VC27 bit in the VCR2 register
I_{det3}: VC26 bit in the VCR2 register

$$V_{CC1}=V_{CC2}=3V$$

Timing Requirements

($V_{CC1} = V_{CC2} = 3V$, $V_{SS} = 0V$, at $T_{opr} = -20$ to $85^{\circ}C$ / -40 to $85^{\circ}C$ unless otherwise specified)

Table 5.32 External Clock Input (XIN input)⁽¹⁾

Symbol	Parameter	Standard		Unit
		Min.	Max.	
t_c	External Clock Input Cycle Time	(NOTE 2)		ns
$t_{w(H)}$	External Clock Input HIGH Pulse Width	(NOTE 3)		ns
$t_{w(L)}$	External Clock Input LOW Pulse Width	(NOTE 3)		ns
t_r	External Clock Rise Time		(NOTE 4)	ns
t_f	External Clock Fall Time		(NOTE 4)	ns

NOTES:

1. The condition is $V_{CC1}=V_{CC2}=2.7$ to $3.0V$.
2. Calculated according to the V_{CC1} voltage as follows:

$$\frac{10^{-6}}{20 \times V_{CC2} - 44} \text{ [ns]}$$

3. Calculated according to the V_{CC1} voltage as follows:

$$\frac{10^{-6}}{20 \times V_{CC1} - 44} \times 0.4 \text{ [ns]}$$

4. Calculated according to the V_{CC1} voltage as follows:

$$-10 \times V_{CC1} + 45 \text{ [ns]}$$

Table 5.33 Memory Expansion Mode and Microprocessor Mode

Symbol	Parameter	Standard		Unit
		Min.	Max.	
$t_{ac1(RD-DB)}$	Data Input Access Time (for setting with no wait)		(NOTE 1)	ns
$t_{ac2(RD-DB)}$	Data Input Access Time (for setting with wait)		(NOTE 2)	ns
$t_{ac3(RD-DB)}$	Data Input Access Time (when accessing multiplex bus area)		(NOTE 3)	ns
$t_{su(DB-RD)}$	Data Input Setup Time	50		ns
$t_{su(RDY-BCLK)}$	RDY Input Setup Time	40		ns
$t_{su(HOLD-BCLK)}$	HOLD Input Setup Time	50		ns
$t_h(RD-DB)$	Data Input Hold Time	0		ns
$t_h(BCLK-RDY)$	RDY Input Hold Time	0		ns
$t_h(BCLK-HOLD)$	HOLD Input Hold Time	0		ns

NOTES:

1. Calculated according to the BCLK frequency as follows:

$$\frac{0.5 \times 10^9}{f(BCLK)} - 60 \text{ [ns]}$$

2. Calculated according to the BCLK frequency as follows:

$$\frac{(n-0.5) \times 10^9}{f(BCLK)} - 60 \text{ [ns]} \quad n \text{ is "2" for 1-wait setting, "3" for 2-wait setting and "4" for 3-wait setting.}$$

3. Calculated according to the BCLK frequency as follows:

$$\frac{(n-0.5) \times 10^9}{f(BCLK)} - 60 \text{ [ns]} \quad n \text{ is "2" for 2-wait setting, "3" for 3-wait setting.}$$

$$V_{CC1}=V_{CC2}=3V$$

Timing Requirements

($V_{CC1} = V_{CC2} = 3V$, $V_{SS} = 0V$, at $T_{opr} = -20$ to $85^{\circ}C$ / -40 to $85^{\circ}C$ unless otherwise specified)

Table 5.34 Timer A Input (Counter Input in Event Counter Mode)

Symbol	Parameter	Standard		Unit
		Min.	Max.	
$t_{c(TA)}$	TAiIN Input Cycle Time	150		ns
$t_{w(TAH)}$	TAiIN Input HIGH Pulse Width	60		ns
$t_{w(TAL)}$	TAiIN Input LOW Pulse Width	60		ns

Table 5.35 Timer A Input (Gating Input in Timer Mode)

Symbol	Parameter	Standard		Unit
		Min.	Max.	
$t_{c(TA)}$	TAiIN Input Cycle Time	600		ns
$t_{w(TAH)}$	TAiIN Input HIGH Pulse Width	300		ns
$t_{w(TAL)}$	TAiIN Input LOW Pulse Width	300		ns

Table 5.36 Timer A Input (External Trigger Input in One-shot Timer Mode)

Symbol	Parameter	Standard		Unit
		Min.	Max.	
$t_{c(TA)}$	TAiIN Input Cycle Time	300		ns
$t_{w(TAH)}$	TAiIN Input HIGH Pulse Width	150		ns
$t_{w(TAL)}$	TAiIN Input LOW Pulse Width	150		ns

Table 5.37 Timer A Input (External Trigger Input in Pulse Width Modulation Mode)

Symbol	Parameter	Standard		Unit
		Min.	Max.	
$t_{w(TAH)}$	TAiIN Input HIGH Pulse Width	150		ns
$t_{w(TAL)}$	TAiIN Input LOW Pulse Width	150		ns

Table 5.38 Timer A Input (Counter Increment/Decrement Input in Event Counter Mode)

Symbol	Parameter	Standard		Unit
		Min.	Max.	
$t_{c(UP)}$	TAiOUT Input Cycle Time	3000		ns
$t_{w(UPH)}$	TAiOUT Input HIGH Pulse Width	1500		ns
$t_{w(UPL)}$	TAiOUT Input LOW Pulse Width	1500		ns
$t_{su(UP-TIN)}$	TAiOUT Input Setup Time	600		ns
$t_{h(TIN-UP)}$	TAiOUT Input Hold Time	600		ns

Table 5.39 Timer A Input (Two-phase Pulse Input in Event Counter Mode)

Symbol	Parameter	Standard		Unit
		Min.	Max.	
$t_{c(TA)}$	TAiIN Input Cycle Time	2		μs
$t_{su(TAIN-TAOUT)}$	TAiOUT Input Setup Time	500		ns
$t_{su(TAOUT-TAIN)}$	TAiIN Input Setup Time	500		ns

$$V_{CC1}=V_{CC2}=3V$$

Timing Requirements

($V_{CC1} = V_{CC2} = 3V$, $V_{SS} = 0V$, at $T_{opr} = -20$ to $85^{\circ}C$ / -40 to $85^{\circ}C$ unless otherwise specified)

Table 5.40 Timer B Input (Counter Input in Event Counter Mode)

Symbol	Parameter	Standard		Unit
		Min.	Max.	
$t_{c(TB)}$	TBiIN Input Cycle Time (counted on one edge)	150		ns
$t_{w(TBH)}$	TBiIN Input HIGH Pulse Width (counted on one edge)	60		ns
$t_{w(TBL)}$	TBiIN Input LOW Pulse Width (counted on one edge)	60		ns
$t_{c(TB)}$	TBiIN Input Cycle Time (counted on both edges)	300		ns
$t_{w(TBH)}$	TBiIN Input HIGH Pulse Width (counted on both edges)	120		ns
$t_{w(TBL)}$	TBiIN Input LOW Pulse Width (counted on both edges)	120		ns

Table 5.41 Timer B Input (Pulse Period Measurement Mode)

Symbol	Parameter	Standard		Unit
		Min.	Max.	
$t_{c(TB)}$	TBiIN Input Cycle Time	600		ns
$t_{w(TBH)}$	TBiIN Input HIGH Pulse Width	300		ns
$t_{w(TBL)}$	TBiIN Input LOW Pulse Width	300		ns

Table 5.42 Timer B Input (Pulse Width Measurement Mode)

Symbol	Parameter	Standard		Unit
		Min.	Max.	
$t_{c(TB)}$	TBiIN Input Cycle Time	600		ns
$t_{w(TBH)}$	TBiIN Input HIGH Pulse Width	300		ns
$t_{w(TBL)}$	TBiIN Input LOW Pulse Width	300		ns

Table 5.43 A/D Trigger Input

Symbol	Parameter	Standard		Unit
		Min.	Max.	
$t_{c(AD)}$	\overline{ADTRG} Input Cycle Time	1500		ns
$t_{w(ADL)}$	\overline{ADTRG} Input LOW Pulse Width	200		ns

Table 5.44 Serial Interface

Symbol	Parameter	Standard		Unit
		Min.	Max.	
$t_{c(CK)}$	CLKi Input Cycle Time	300		ns
$t_{w(CKH)}$	CLKi Input HIGH Pulse Width	150		ns
$t_{w(CKL)}$	CLKi Input LOW Pulse Width	150		ns
$t_d(C-Q)$	TXDi Output Delay Time		160	ns
$t_h(C-Q)$	TXDi Hold Time	0		ns
$t_{su}(D-C)$	RXDi Input Setup Time	100		ns
$t_h(C-D)$	RXDi Input Hold Time	90		ns

Table 5.45 External Interrupt \overline{INTi} Input

Symbol	Parameter	Standard		Unit
		Min.	Max.	
$t_{w(INH)}$	\overline{INTi} Input HIGH Pulse Width	380		ns
$t_{w(INL)}$	\overline{INTi} Input LOW Pulse Width	380		ns

$$V_{CC1} = V_{CC2} = 3V$$

Switching Characteristics

(V_{CC1} = V_{CC2} = 3V, V_{SS} = 0V, at T_{opr} = -20 to 85°C / -40 to 85°C unless otherwise specified)

Table 5.46 Memory Expansion and Microprocessor Modes (for setting with no wait)

Symbol	Parameter		Standard		Unit
			Min.	Max.	
t _d (BCLK-AD)	Address Output Delay Time	See Figure 5.12		30	ns
t _h (BCLK-AD)	Address Output Hold Time (in relation to BCLK)		4		ns
t _h (RD-AD)	Address Output Hold Time (in relation to RD)		0		ns
t _h (WR-AD)	Address Output Hold Time (in relation to WR)		(NOTE 2)		ns
t _d (BCLK-CS)	Chip Select Output Delay Time			30	ns
t _h (BCLK-CS)	Chip Select Output Hold Time (in relation to BCLK)		4		ns
t _d (BCLK-ALE)	ALE Signal Output Delay Time			25	ns
t _h (BCLK-ALE)	ALE Signal Output Hold Time		-4		ns
t _d (BCLK-RD)	RD Signal Output Delay Time			30	ns
t _h (BCLK-RD)	RD Signal Output Hold Time		0		ns
t _d (BCLK-WR)	WR Signal Output Delay Time			30	ns
t _h (BCLK-WR)	WR Signal Output Hold Time		0		ns
t _d (BCLK-DB)	Data Output Delay Time (in relation to BCLK)			40	ns
t _h (BCLK-DB)	Data Output Hold Time (in relation to BCLK) ⁽³⁾		4		ns
t _d (DB-WR)	Data Output Delay Time (in relation to WR)		(NOTE 1)		ns
t _h (WR-DB)	Data Output Hold Time (in relation to WR) ⁽³⁾		(NOTE 2)		ns
t _d (BCLK-HLDA)	HLDA Output Delay Time		40	ns	

NOTES:

1. Calculated according to the BCLK frequency as follows:

$$\frac{0.5 \times 10^9}{f(\text{BCLK})} - 40[\text{ns}] \quad f(\text{BCLK}) \text{ is } 12.5\text{MHz or less.}$$

2. Calculated according to the BCLK frequency as follows:

$$\frac{0.5 \times 10^9}{f(\text{BCLK})} - 10[\text{ns}]$$

3. This standard value shows the timing when the output is off, and does not show hold time of data bus.

Hold time of data bus varies with capacitor volume and pull-up (pull-down) resistance value.

Hold time of data bus is expressed in

$$t = -CR \times \ln(1 - V_{OL} / V_{CC2})$$

by a circuit of the right figure.

For example, when V_{OL} = 0.2V_{CC2}, C = 30pF, R = 1kΩ, hold time of output "L" level is

$$t = -30\text{pF} \times 1\text{k}\Omega \times \ln(1 - 0.2V_{CC2} / V_{CC2}) = 6.7\text{ns.}$$

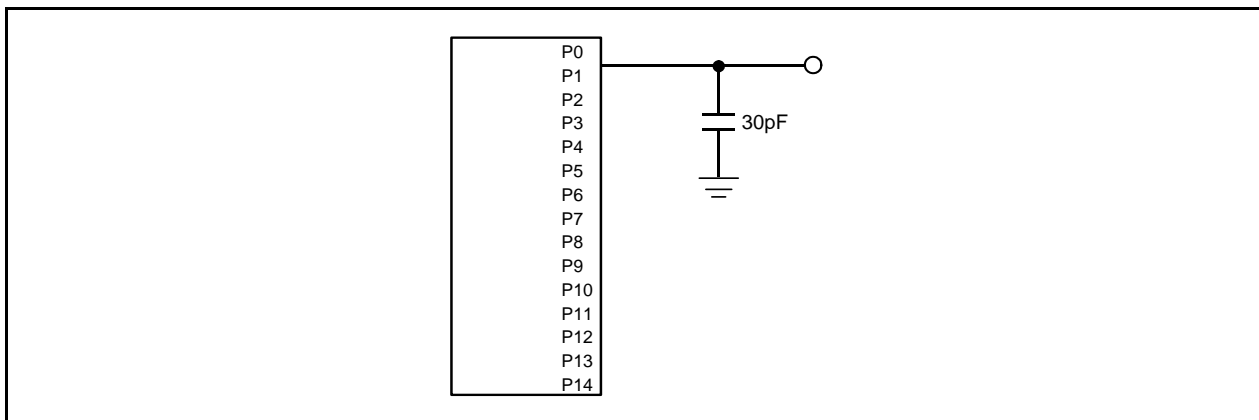
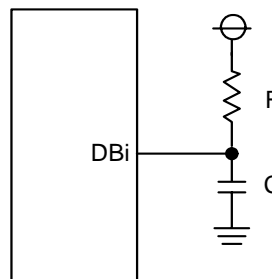


Figure 5.12 Ports P0 to P14 Measurement Circuit

$$V_{CC1}=V_{CC2}=3V$$

Switching Characteristics

($V_{CC1} = V_{CC2} = 5V$, $V_{SS} = 0V$, at $T_{opr} = -20$ to $85^{\circ}C$ / -40 to $85^{\circ}C$ unless otherwise specified)

Table 5.47 Memory Expansion and Microprocessor Modes (for 1- to 3-wait setting and external area access)

Symbol	Parameter		Standard		Unit
			Min.	Max.	
$t_{d(BCLK-AD)}$	Address Output Delay Time	See Figure 5.12		30	ns
$t_{h(BCLK-AD)}$	Address Output Hold Time (in relation to BCLK)		4		ns
$t_{h(RD-AD)}$	Address Output Hold Time (in relation to RD)		0		ns
$t_{h(WR-AD)}$	Address Output Hold Time (in relation to WR)		(NOTE 2)		ns
$t_{d(BCLK-CS)}$	Chip Select Output Delay Time			30	ns
$t_{h(BCLK-CS)}$	Chip Select Output Hold Time (in relation to BCLK)		4		ns
$t_{d(BCLK-ALE)}$	ALE Signal Output Delay Time			25	ns
$t_{h(BCLK-ALE)}$	ALE Signal Output Hold Time		-4		ns
$t_{d(BCLK-RD)}$	RD Signal Output Delay Time			30	ns
$t_{h(BCLK-RD)}$	RD Signal Output Hold Time		0		ns
$t_{d(BCLK-WR)}$	WR Signal Output Delay Time			30	ns
$t_{h(BCLK-WR)}$	WR Signal Output Hold Time		0		ns
$t_{d(BCLK-DB)}$	Data Output Delay Time (in relation to BCLK)			40	ns
$t_{h(BCLK-DB)}$	Data Output Hold Time (in relation to BCLK) ⁽³⁾		4		ns
$t_{d(DB-WR)}$	Data Output Delay Time (in relation to WR)		(NOTE 1)		ns
$t_{h(WR-DB)}$	Data Output Hold Time (in relation to WR) ⁽³⁾		(NOTE 2)		ns
$t_{d(BCLK-HLDA)}$	HLDA Output Delay Time		40	ns	

NOTES:

1. Calculated according to the BCLK frequency as follows:

$$\frac{(n-0.5) \times 10^9}{f(\text{BCLK})} - 40[\text{ns}]$$

n is "1" for 1-wait setting, "2" for 2-wait setting and "3" for 3-wait setting.
(BCLK) is 12.5MHz or less.

2. Calculated according to the BCLK frequency as follows:

$$\frac{0.5 \times 10^9}{f(\text{BCLK})} - 10[\text{ns}]$$

3. This standard value shows the timing when the output is off, and does not show hold time of data bus.

Hold time of data bus varies with capacitor volume and pull-up (pull-down) resistance value.

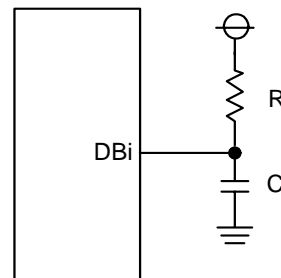
Hold time of data bus is expressed in

$$t = -CR \times \ln(1 - V_{OL} / V_{CC2})$$

by a circuit of the right figure.

For example, when $V_{OL} = 0.2V_{CC2}$, $C = 30\text{pF}$, $R = 1\text{k}\Omega$, hold time of output "L" level is

$$t = -30\text{pF} \times 1\text{k}\Omega \times \ln(1 - 0.2V_{CC2} / V_{CC2}) = 6.7\text{ns}.$$



$$V_{CC1}=V_{CC2}=3V$$

Switching Characteristics

(V_{CC1} = V_{CC2} = 5V, V_{SS} = 0V, at T_{opr} = –20 to 85°C / –40 to 85°C unless otherwise specified)

Table 5.48 Memory Expansion and Microprocessor Modes (for 2- to 3-wait setting, external area access and multiplex bus selection)

Symbol	Parameter		Standard		Unit
			Min.	Max.	
t _d (BCLK-AD)	Address Output Delay Time	See Figure 5.12		50	ns
t _h (BCLK-AD)	Address Output Hold Time (in relation to BCLK)		4		ns
t _h (RD-AD)	Address Output Hold Time (in relation to RD)		(NOTE 1)		ns
t _h (WR-AD)	Address Output Hold Time (in relation to WR)		(NOTE 1)		ns
t _d (BCLK-CS)	Chip Select Output Delay Time			50	ns
t _h (BCLK-CS)	Chip Select Output Hold Time (in relation to BCLK)		4		ns
t _h (RD-CS)	Chip Select Output Hold Time (in relation to RD)		(NOTE 1)		ns
t _h (WR-CS)	Chip Select Output Hold Time (in relation to WR)		(NOTE 1)		ns
t _d (BCLK-RD)	RD Signal Output Delay Time			40	ns
t _h (BCLK-RD)	RD Signal Output Hold Time		0		ns
t _d (BCLK-WR)	WR Signal Output Delay Time			40	ns
t _h (BCLK-WR)	WR Signal Output Hold Time		0		ns
t _d (BCLK-DB)	Data Output Delay Time (in relation to BCLK)			50	ns
t _h (BCLK-DB)	Data Output Hold Time (in relation to BCLK)		4		ns
t _d (DB-WR)	Data Output Delay Time (in relation to WR)		(NOTE 2)		ns
t _h (WR-DB)	Data Output Hold Time (in relation to WR)		(NOTE 1)		ns
t _d (BCLK-HLDA)	HLDA Output Delay Time			40	ns
t _d (BCLK-ALE)	ALE Signal Output Delay Time (in relation to BCLK)			25	ns
t _h (BCLK-ALE)	ALE Signal Output Hold Time (in relation to BCLK)		–4		ns
t _d (AD-ALE)	ALE Signal Output Delay Time (in relation to Address)		(NOTE 3)		ns
t _h (AD-ALE)	ALE Signal Output Hold Time (in relation to Address)		(NOTE 4)		ns
t _d (AD-RD)	RD Signal Output Delay From the End of Address		0		ns
t _d (AD-WR)	WR Signal Output Delay From the End of Address		0		ns
t _{dz} (RD-AD)	Address Output Floating Start Time			8	ns

NOTES:

1. Calculated according to the BCLK frequency as follows:

$$\frac{0.5 \times 10^9}{f(\text{BCLK})} - 10[\text{ns}]$$

2. Calculated according to the BCLK frequency as follows:

$$\frac{0.5 \times 10^9}{f(\text{BCLK})} - 50[\text{ns}] \quad \text{n is "2" for 2-wait setting, "3" for 3-wait setting.}$$

3. Calculated according to the BCLK frequency as follows:

$$\frac{0.5 \times 10^9}{f(\text{BCLK})} - 40[\text{ns}]$$

4. Calculated according to the BCLK frequency as follows:

$$\frac{0.5 \times 10^9}{f(\text{BCLK})} - 15[\text{ns}]$$



Figure 5.13 Timing Diagram (1)



Figure 5.14 Timing Diagram (2)

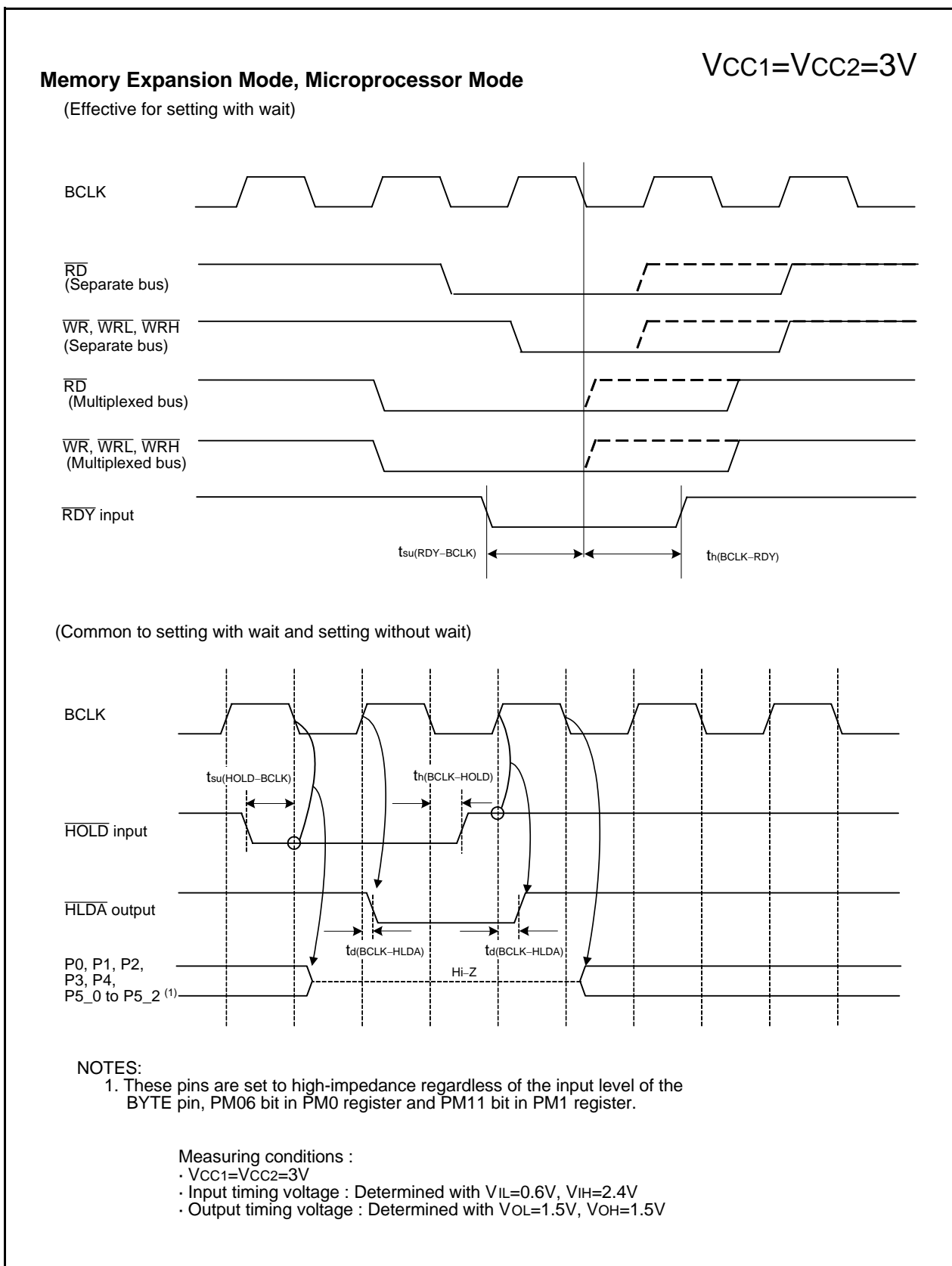


Figure 5.15 Timing Diagram (3)

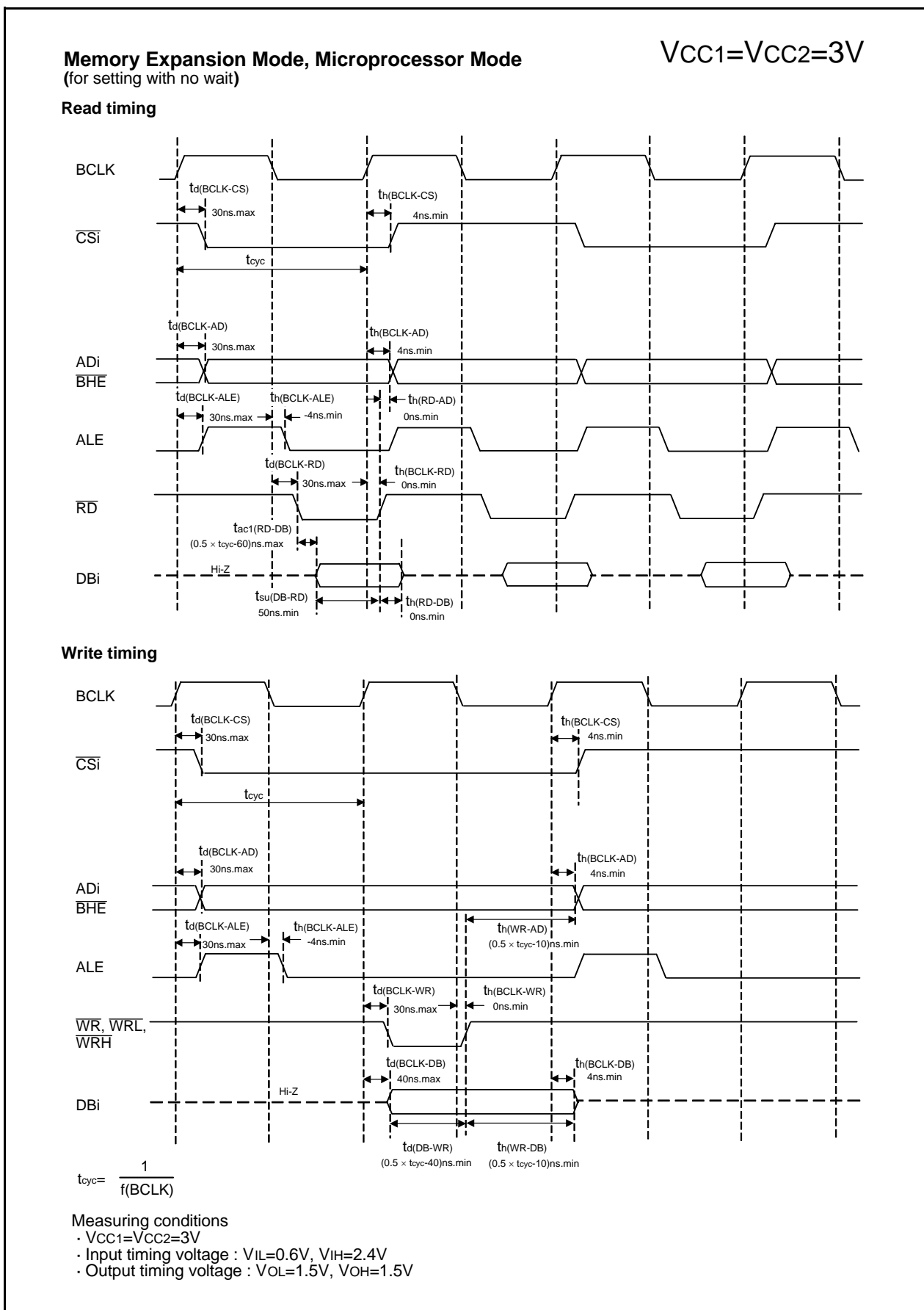


Figure 5.16 Timing Diagram (4)

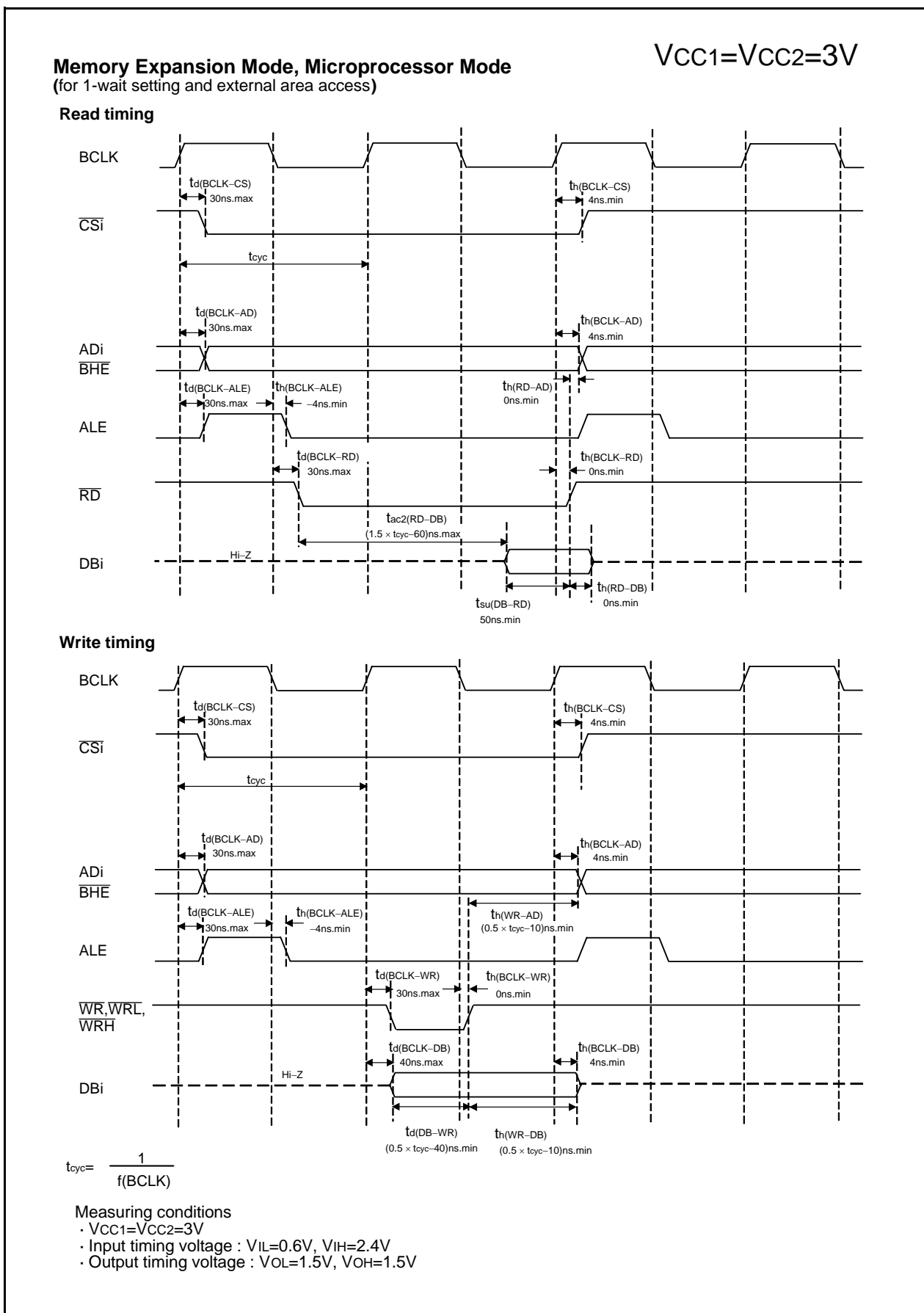


Figure 5.17 Timing Diagram (5)

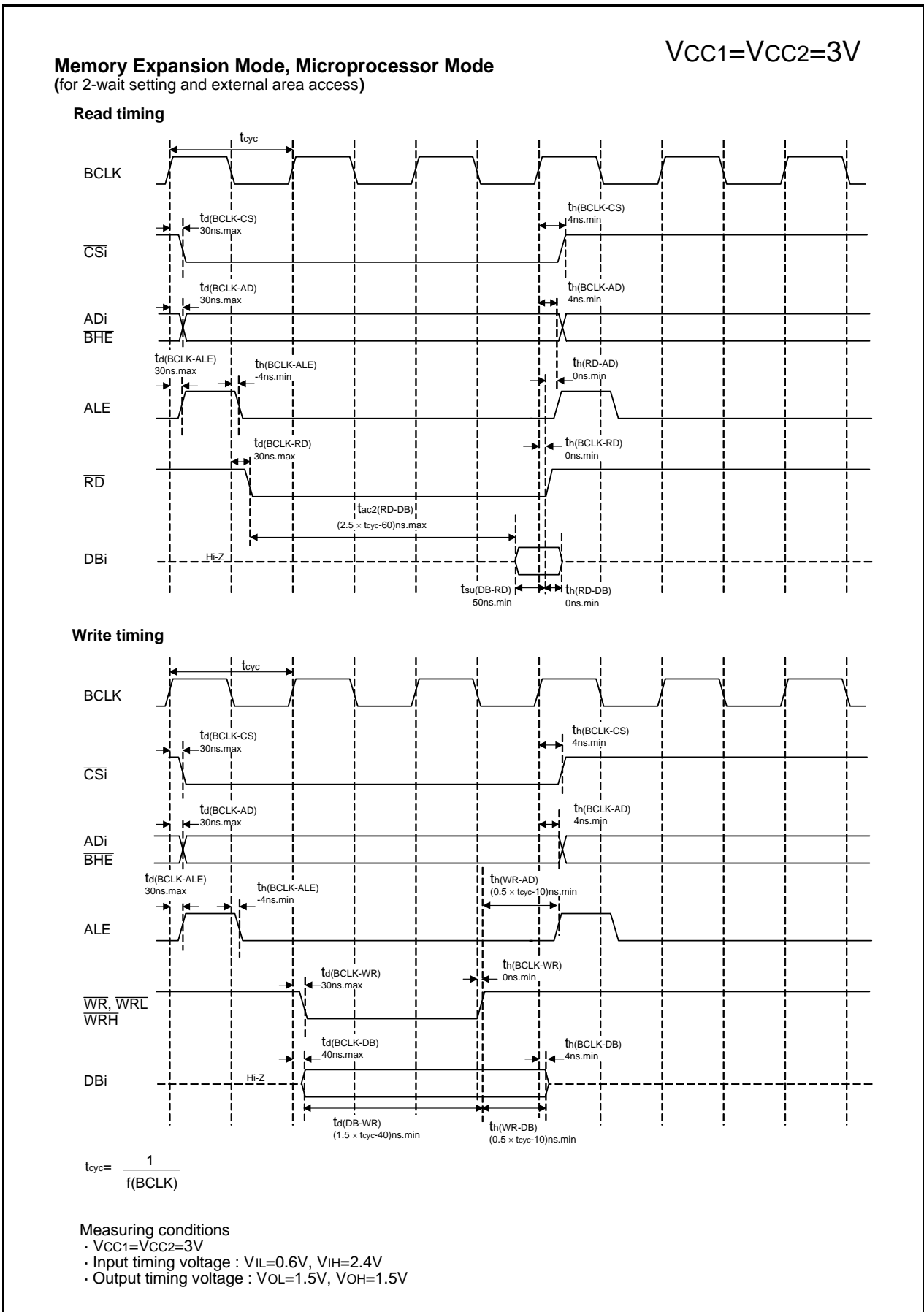


Figure 5.18 Timing Diagram (6)

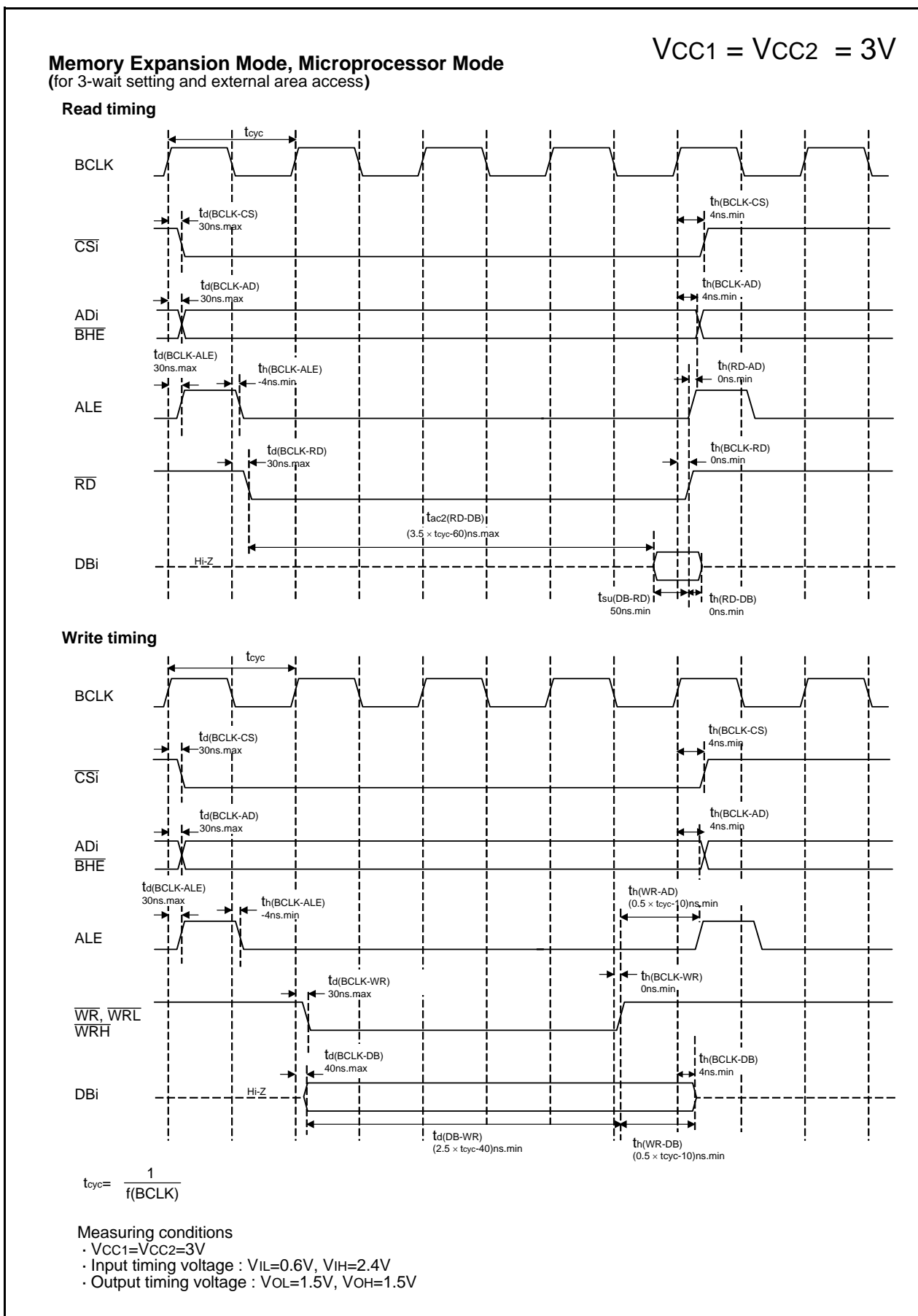


Figure 5.19 Timing Diagram (7)



Figure 5.20 Timing Diagram (8)

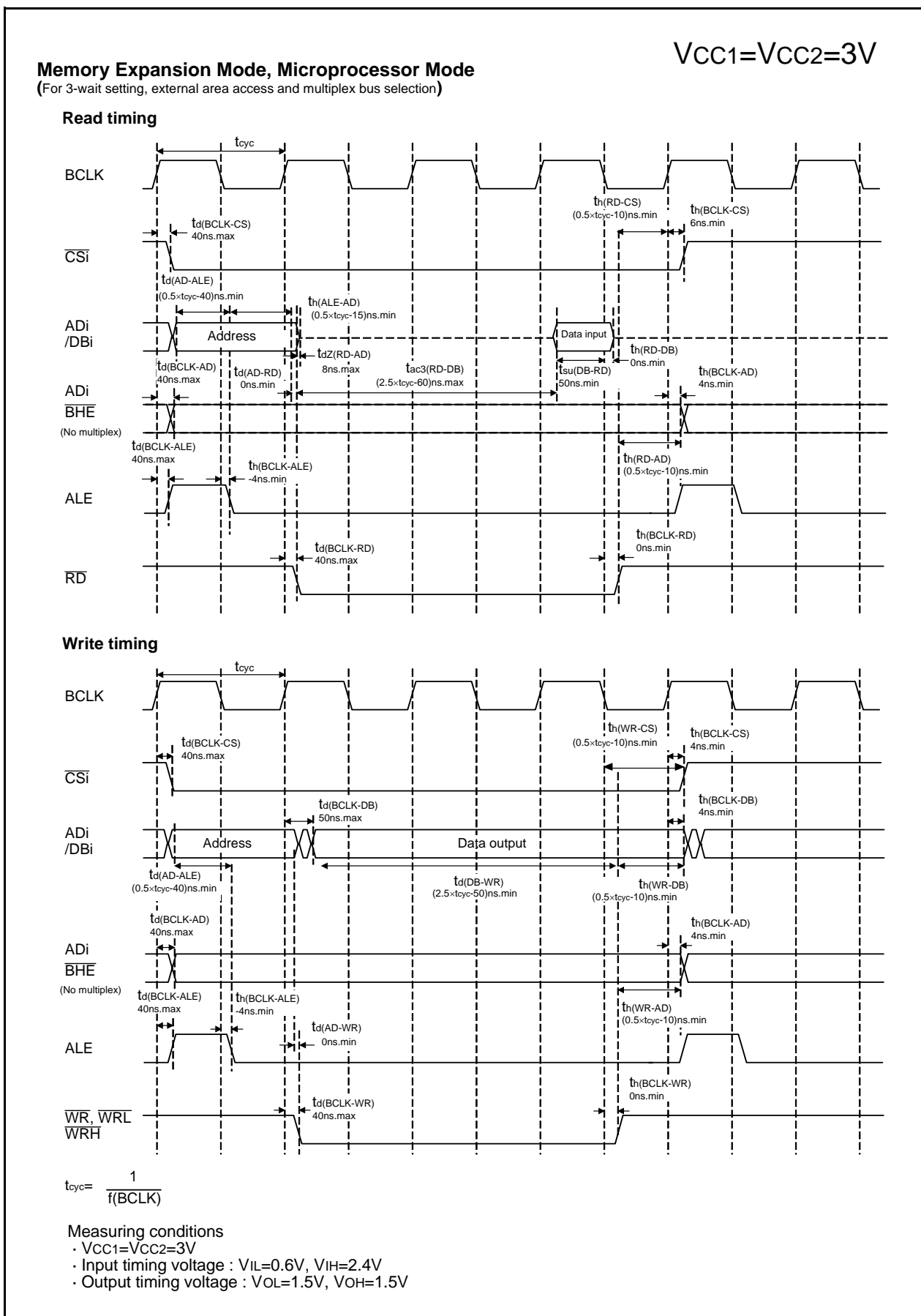


Figure 5.21 Timing Diagram (9)

5.2 Electrical Characteristics (M16C/62PT)

Table 5.49 Absolute Maximum Ratings

Symbol	Parameter		Condition	Rated Value	Unit
V _{CC1} , V _{CC2}	Supply Voltage		V _{CC1} =V _{CC2} =AV _{CC}	-0.3 to 6.5	V
AV _{CC}	Analog Supply Voltage		V _{CC1} =V _{CC2} =AV _{CC}	-0.3 to 6.5	V
V _i	Input Voltage	RESET, CNVSS, BYTE, P6_0 to P6_7, P7_2 to P7_7, P8_0 to P8_7, P9_0 to P9_7, P10_0 to P10_7, P11_0 to P11_7, P14_0, P14_1, VREF, XIN		-0.3 to V _{CC1} +0.3 (1)	V
		P0_0 to P0_7, P1_0 to P1_7, P2_0 to P2_7, P3_0 to P3_7, P4_0 to P4_7, P5_0 to P5_7, P12_0 to P12_7, P13_0 to P13_7		-0.3 to V _{CC2} +0.3 (1)	V
		P7_0, P7_1		-0.3 to 6.5	V
V _o	Output Voltage	P6_0 to P6_7, P7_2 to P7_7, P8_0 to P8_4, P8_6, P8_7, P9_0 to P9_7, P10_0 to P10_7, P11_0 to P11_7, P14_0, P14_1, XOUT		-0.3 to V _{CC1} +0.3 (1)	V
		P0_0 to P0_7, P1_0 to P1_7, P2_0 to P2_7, P3_0 to P3_7, P4_0 to P4_7, P5_0 to P5_7, P12_0 to P12_7, P13_0 to P13_7		-0.3 to V _{CC2} +0.3 (1)	V
		P7_0, P7_1		-0.3 to 6.5	V
P _d	Power Dissipation		-40°C < T _{opr} ≤ 85°C	300	mW
			85°C < T _{opr} ≤ 125°C	200	
T _{opr}	Operating Ambient Temperature	When the Microcomputer is Operating		-40 to 85 / -40 to 125 (2)	°C
		Flash Program Erase		0 to 60	
T _{stg}	Storage Temperature			-65 to 150	°C

NOTES:

1. There is no external connections for port P1_0 to P1_7, P4_4 to P4_7, P7_2 to P7_5 and P9_1 in 80-pin version.
2. T version = -40 to 85 °C, V version = -40 to 125 °C.

Table 5.50 Recommended Operating Conditions (1) (1)

Symbol	Parameter		Standard			Unit
			Min.	Typ.	Max.	
V _{CC1} , V _{CC2}	Supply Voltage (V _{CC1} = V _{CC2})		4.0	5.0	5.5	V
AV _{CC}	Analog Supply Voltage			V _{CC1}		V
V _{SS}	Supply Voltage			0		V
AV _{SS}	Analog Supply Voltage			0		V
V _{IH}	HIGH Input Voltage (4)	P3_1 to P3_7, P4_0 to P4_7, P5_0 to P5_7, P12_0 to P12_7, P13_0 to P13_7	0.8V _{CC2}		V _{CC2}	V
		P0_0 to P0_7, P1_0 to P1_7, P2_0 to P2_7, P3_0 (during single-chip mode)	0.8V _{CC2}		V _{CC2}	V
		P6_0 to P6_7, P7_2 to P7_7, P8_0 to P8_7, P9_0 to P9_7, P10_0 to P10_7, P11_0 to P11_7, P14_0, P14_1, XIN, RESET, CNVSS, BYTE	0.8V _{CC1}		V _{CC1}	V
		P7_0, P7_1	0.8V _{CC1}		6.5	V
V _{IL}	LOW Input Voltage (4)	P3_1 to P3_7, P4_0 to P4_7, P5_0 to P5_7, P12_0 to P12_7, P13_0 to P13_7	0		0.2V _{CC2}	V
		P0_0 to P0_7, P1_0 to P1_7, P2_0 to P2_7, P3_0 (during single-chip mode)	0		0.2V _{CC2}	V
		P6_0 to P6_7, P7_0 to P7_7, P8_0 to P8_7, P9_0 to P9_7, P10_0 to P10_7, P11_0 to P11_7, P14_0, P14_1, XIN, RESET, CNVSS, BYTE	0		0.2V _{CC}	V
I _{OH(peak)}	HIGH Peak Output Current (4)	P0_0 to P0_7, P1_0 to P1_7, P2_0 to P2_7, P3_0 to P3_7, P4_0 to P4_7, P5_0 to P5_7, P6_0 to P6_7, P7_2 to P7_7, P8_0 to P8_4, P8_6, P8_7, P9_0 to P9_7, P10_0 to P10_7, P11_0 to P11_7, P12_0 to P12_7, P13_0 to P13_7, P14_0, P14_1			-10.0	mA
I _{OH(avg)}	HIGH Average Output Current (4)	P0_0 to P0_7, P1_0 to P1_7, P2_0 to P2_7, P3_0 to P3_7, P4_0 to P4_7, P5_0 to P5_7, P6_0 to P6_7, P7_2 to P7_7, P8_0 to P8_4, P8_6, P8_7, P9_0 to P9_7, P10_0 to P10_7, P11_0 to P11_7, P12_0 to P12_7, P13_0 to P13_7, P14_0, P14_1			-5.0	mA
I _{OL(peak)}	LOW Peak Output Current (4)	P0_0 to P0_7, P1_0 to P1_7, P2_0 to P2_7, P3_0 to P3_7, P4_0 to P4_7, P5_0 to P5_7, P6_0 to P6_7, P7_0 to P7_7, P8_0 to P8_4, P8_6, P8_7, P9_0 to P9_7, P10_0 to P10_7, P11_0 to P11_7, P12_0 to P12_7, P13_0 to P13_7, P14_0, P14_1			10.0	mA
I _{OL(avg)}	LOW Average Output Current (4)	P0_0 to P0_7, P1_0 to P1_7, P2_0 to P2_7, P3_0 to P3_7, P4_0 to P4_7, P5_0 to P5_7, P6_0 to P6_7, P7_0 to P7_7, P8_0 to P8_4, P8_6, P8_7, P9_0 to P9_7, P10_0 to P10_7, P11_0 to P11_7, P12_0 to P12_7, P13_0 to P13_7, P14_0, P14_1			5.0	mA
f(XIN)	Main Clock Input Oscillation Frequency	V _{CC1} =4.0V to 5.5V	0		16	MHz
f(XCIN)	Sub-Clock Oscillation Frequency			32.768	50	kHz
f(Ring)	On-chip Oscillation Frequency		0.5	1	2	MHz
f(PLL)	PLL Clock Oscillation Frequency	V _{CC1} =4.0V to 5.5V	10		24	MHz
f(BCLK)	CPU Operation Clock		0		24	MHz
tsu(PLL)	PLL Frequency Synthesizer Stabilization Wait Time	V _{CC1} =5.5V			20	ms

NOTES:

1. Referenced to V_{CC1} = V_{CC2} = 4.7 to 5.5V at T_{opr} = -40 to 85°C / -40 to 125°C unless otherwise specified.
T version = -40 to 85 °C, V version = -40 to 125 °C.
2. The Average Output Current is the mean value within 100ms.
3. The total I_{OL(peak)} for ports P0, P1, P2, P8_6, P8_7, P9, P10 P1, P14_0 and P14_1 must be 80mA max. The total I_{OL(peak)} for ports P3, P4, P5, P6, P7, P8_0 to P8_4, P12, and P13 must be 80mA max. The total I_{OH(peak)} for ports P0, P1, and P2 must be -40mA max. The total I_{OH(peak)} for ports P3, P4, P5, P12, and P13 must be -40mA max. The total I_{OH(peak)} for ports P6, P7, and P8_0 to P8_4 must be -40mA max. The total I_{OH(peak)} for ports P8_6, P8_7, P9, P10, P11, P14_0, and P14_1 must be -40mA max.
As for 80-pin version, the total I_{OL(peak)} for all ports and I_{OH(peak)} must be 80mA. max. due to one V_{CC} and one V_{SS}.
4. There is no external connections for port P1_0 to P1_7, P4_4 to P4_7, P7_2 to P7_5 and P9_1 in 80-pin version.

Table 5.51 A/D Conversion Characteristics (1)

Symbol	Parameter		Measuring Condition	Standard			Unit
				Min.	Typ.	Max.	
–	Resolution		$V_{REF}=V_{CC1}$			10	Bits
INL	Integral Non-Linearity Error	10bit	$V_{REF}=V_{CC1}=5V$ AN0 to AN7 input, AN0_0 to AN0_7 input, AN2_0 to AN2_7 input, ANEX0, ANEX1 input			± 3	LSB
			External operation amp connection mode			± 7	LSB
		8bit	$V_{REF}=V_{CC1}=5V$			± 2	LSB
–	Absolute Accuracy	10bit	$V_{REF}=V_{CC1}=5V$ AN0 to AN7 input, AN0_0 to AN0_7 input, AN2_0 to AN2_7 input, ANEX0, ANEX1 input			± 3	LSB
			External operation amp connection mode			± 7	LSB
		8bit	$V_{REF}=V_{CC1}=5V$			± 2	LSB
–	Tolerance Level Impedance				3		$k\Omega$
DNL	Differential Non-Linearity Error					± 1	LSB
–	Offset Error					± 3	LSB
–	Gain Error					± 3	LSB
RLADDER	Ladder Resistance		$V_{REF}=V_{CC1}$	10		40	$k\Omega$
tCONV	10-bit Conversion Time, Sample & Hold Function Available		$V_{REF}=V_{CC1}=5V, \phi_{AD}=12MHz$	2.75			μs
tCONV	8-bit Conversion Time, Sample & Hold Function Available		$V_{REF}=V_{CC1}=5V, \phi_{AD}=12MHz$	2.33			μs
tsAMP	Sampling Time			0.25			μs
VREF	Reference Voltage			2.0		V_{CC1}	V
VIA	Analog Input Voltage			0		V_{REF}	V

NOTES:

1. Referenced to $V_{CC1}=AV_{CC}=V_{REF}=4.0$ to $5.5V$, $V_{SS}=AV_{SS}=0V$ at $T_{opr} = -40$ to $85^\circ C / -40$ to $125^\circ C$ unless otherwise specified. T version = -40 to $85^\circ C$, V version = -40 to $125^\circ C$
2. ϕ_{AD} frequency must be 12 MHz or less.
3. When sample & hold is disabled, ϕ_{AD} frequency must be 250 kHz or more, in addition to the limitation in Note 2. When sample & hold is enabled, ϕ_{AD} frequency must be 1MHz or more, in addition to the limitation in Note 2.

Table 5.52 D/A Conversion Characteristics (1)

Symbol	Parameter	Measuring Condition	Standard			Unit
			Min.	Typ.	Max.	
–	Resolution				8	Bits
–	Absolute Accuracy				1.0	%
tsU	Setup Time				3	μs
RO	Output Resistance		4	10	20	$k\Omega$
I _{VREF}	Reference Power Supply Input Current	(NOTE 2)			1.5	mA

NOTES:

1. Referenced to $V_{CC1}=V_{REF}=4.0$ to $5.5V$, $V_{SS}=AV_{SS}=0V$ at $T_{opr} = -40$ to $85^\circ C / -40$ to $125^\circ C$ unless otherwise specified. T version = -40 to $85^\circ C$, V version = -40 to $125^\circ C$
2. This applies when using one D/A converter, with the D/A register for the unused D/A converter set to "00h". The resistor ladder of the A/D converter is not included. Also, when D/A register contents are not "00h", the I_{VREF} will flow even if V_{ref} is disconnected by the A/D control register.

Table 5.53 Flash Memory Version Electrical Characteristics ⁽¹⁾ for 100 cycle products (B, U)

Symbol	Parameter		Standard			Unit
			Min.	Typ.	Max.	
–	Program and Erase Endurance ⁽³⁾		100			cycle
–	Word Program Time (V _{CC1} =5.0V)			25	200	μs
–	Lock Bit Program Time			25	200	μs
–	Block Erase Time (V _{CC1} =5.0V)	4-Kbyte block	4	0.3	4	s
–		8-Kbyte block		0.3	4	s
–		32-Kbyte block		0.5	4	s
–		64-Kbyte block		0.8	4	s
–	Erase All Unlocked Blocks Time ⁽²⁾				4xn	s
tps	Flash Memory Circuit Stabilization Wait Time				15	μs
–	Data Hold Time ⁽⁵⁾		20			year

Table 5.54 Flash Memory Version Electrical Characteristics ⁽⁶⁾ for 10,000 cycle products (B7, U7) (Block A and Block 1 ⁽⁷⁾)

Symbol	Parameter		Standard			Unit
			Min.	Typ.	Max.	
–	Program and Erase Endurance ^(3, 8, 9)		10,000 ⁽⁴⁾			cycle
–	Word Program Time (V _{CC1} =5.0V)			25		μs
–	Lock Bit Program Time			25		μs
–	Block Erase Time (V _{CC1} =5.0V)	4-Kbyte block	4	0.3		s
tps		Flash Memory Circuit Stabilization Wait Time				15
–	Data Hold Time ⁽⁵⁾		20			year

NOTES:

1. Referenced to V_{CC1}=4.5 to 5.5V at T_{opr} = 0 to 60 °C unless otherwise specified.
2. n denotes the number of block erases.
3. Program and Erase Endurance refers to the number of times a block erase can be performed.
If the program and erase endurance is n (n=100, 1,000, or 10,000), each block can be erased n times.
For example, if a 4 Kbytes block A is erased after writing 1 word data 2,048 times, each to a different address, this counts as one program and erase endurance. Data cannot be written to the same address more than once without erasing the block. (Rewrite prohibited)
4. Maximum number of E/W cycles for which operation is guaranteed.
5. T_a (ambient temperature)=55 °C. As to the data hold time except T_a=55 °C, please contact Renesas Technology Corp. or an authorized Renesas Technology Corp. product distributor.
6. Referenced to V_{CC1} = 4.5 to 5.5V at T_{opr} = –40 to 85 °C (B7, U7 (T version)) / –40 to 125 °C (B7, U7 (V version)) unless otherwise specified.
7. Table 5.54 applies for block A or block 1 program and erase endurance > 1,000. Otherwise, use Table 5.53.
8. To reduce the number of program and erase endurance when working with systems requiring numerous rewrites, write to unused word addresses within the block instead of rewrite. Erase block only after all possible addresses are used. For example, an 8-word program can be written 256 times maximum before erase becomes necessary.
Maintaining an equal number of erasure between block A and block 1 will also improve efficiency. It is important to track the total number of times erasure is used.
9. Should erase error occur during block erase, attempt to execute clear status register command, then block erase command at least three times until erase error disappears.
10. Set the PM17 bit in the PM1 register to “1” (wait state) when executing more than 100 times rewrites (B7 and U7).
11. Customers desiring E/W failure rate information should contact their Renesas technical support representative.

Table 5.55 Flash Memory Version Program/Erase Voltage and Read Operation Voltage Characteristics (at T_{opr} = 0 to 60 °C(B, U), T_{opr} = –40 to 85 °C (B7, U7 (T version)) / –40 to 125 °C (B7, U7 (V version))

Flash Program, Erase Voltage V _{CC1} = 5.0 V ± 0.5 V	Flash Read Operation Voltage V _{CC1} =4.0 to 5.5 V
--	--

Table 5.56 Power Supply Circuit Timing Characteristics

Symbol	Parameter	Measuring Condition	Standard			Unit
			Min.	Typ.	Max.	
td(P-R)	Time for Internal Power Supply Stabilization During Powering-On	Vcc1=4.0V to 5.5V			2	ms
td(R-S)	STOP Release Time				150	μs
td(W-S)	Low Power Dissipation Mode Wait Mode Release Time				150	μs

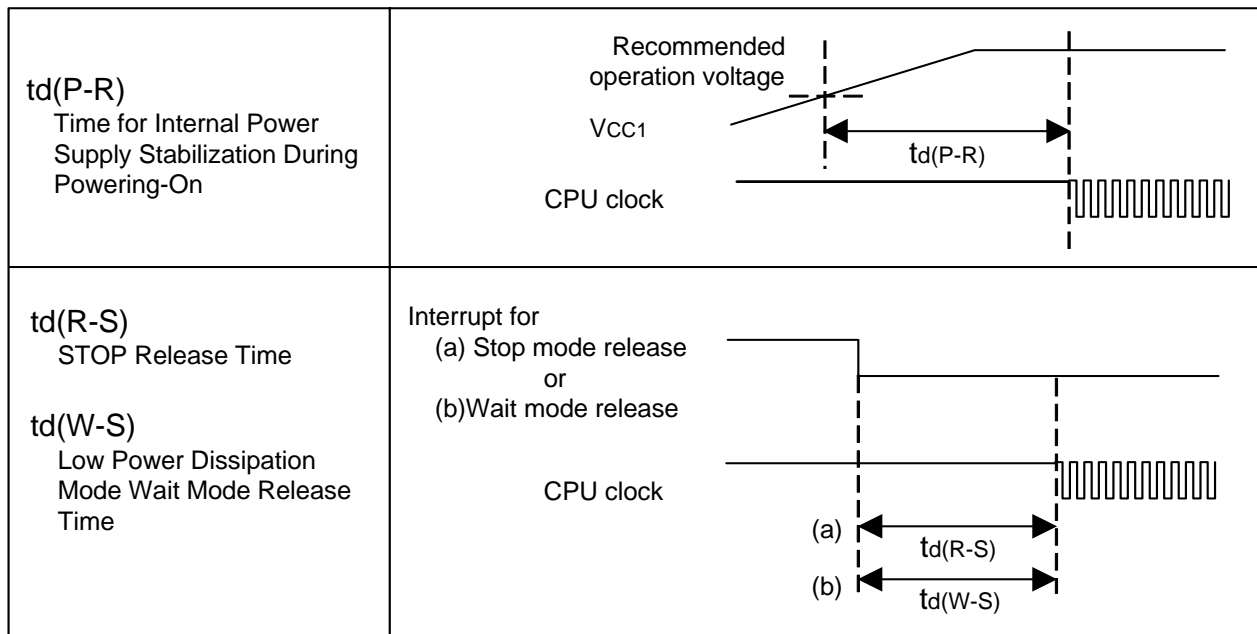


Figure 5.22 Power Supply Circuit Timing Diagram

$$V_{CC1}=V_{CC2}=5V$$

Table 5.57 Electrical Characteristics (1) (1)

Symbol	Parameter		Measuring Condition	Standard			Unit
				Min.	Typ.	Max.	
VOH	HIGH Output Voltage (2)	P6_0 to P6_7, P7_2 to P7_7, P8_0 to P8_4, P8_6, P8_7, P9_0 to P9_7, P10_0 to P10_7, P11_0 to P11_7, P14_0, P14_1	IOH=-5mA	VCC1-2.0		VCC1	V
		P0_0 to P0_7, P1_0 to P1_7, P2_0 to P2_7, P3_0 to P3_7, P4_0 to P4_7, P5_0 to P5_7, P12_0 to P12_7, P13_0 to P13_7	IOH=-5mA	VCC2-2.0		VCC2	
VOH	HIGH Output Voltage (2)	P6_0 to P6_7, P7_2 to P7_7, P8_0 to P8_4, P8_6, P8_7, P9_0 to P9_7, P10_0 to P10_7, P11_0 to P11_7, P14_0, P14_1	OH=-200μA	VCC1-0.3		VCC1	V
		P0_0 to P0_7, P1_0 to P1_7, P2_0 to P2_7, P3_0 to P3_7, P4_0 to P4_7, P5_0 to P5_7, P12_0 to P12_7, P13_0 to P13_7	IOH=-200μA	VCC2-0.3		VCC2	
VOH	HIGH Output Voltage XOUT	HIGHPOWER	IOH=-1mA	VCC1-2.0		VCC1	V
			LOWPOWER	IOH=-0.5mA	VCC1-2.0		
	HIGH Output Voltage XCOUT	HIGHPOWER	With no load applied		2.5		V
			LOWPOWER	With no load applied		1.6	
VOL	LOW Output Voltage (2)	P6_0 to P6_7, P7_0 to P7_7, P8_0 to P8_4, P8_6, P8_7, P9_0 to P9_7, P10_0 to P10_7, P11_0 to P11_7, P14_0, P14_1	IOI=5mA			2.0	V
		P0_0 to P0_7, P1_0 to P1_7, P2_0 to P2_7, P3_0 to P3_7, P4_0 to P4_7, P5_0 to P5_7, P12_0 to P12_7, P13_0 to P13_7	IOI=5mA			2.0	
VOL	LOW Output Voltage (2)	P6_0 to P6_7, P7_0 to P7_7, P8_0 to P8_4, P8_6, P8_7, P9_0 to P9_7, P10_0 to P10_7, P11_0 to P11_7, P14_0, P14_1	IOI=200μA			0.45	V
		P0_0 to P0_7, P1_0 to P1_7, P2_0 to P2_7, P3_0 to P3_7, P4_0 to P4_7, P5_0 to P5_7, P12_0 to P12_7, P13_0 to P13_7	IOI=200μA			0.45	
VOL	LOW Output Voltage XOUT	HIGHPOWER	IOI=1mA			2.0	V
			LOWPOWER	IOI=0.5mA			
	LOW Output Voltage XCOUT	HIGHPOWER	With no load applied		0		V
			LOWPOWER	With no load applied		0	
V _{T+} -V _{T-}	Hysteresis	HOLD, RDY, TA0IN to TA4IN, TB0IN to TB5IN, INT0 to INT5, NMI, ADTRG, CTS0 to CTS2, CLK0 to CLK4, TA0OUT to TA4OUT, KI0 to KI3, RXD0 to RXD2, SCL0 to SCL2, SDA0 to SDA2, SIN3, SIN4		0.2		1.0	V
V _{T+} -V _{T-}	Hysteresis	RESET		0.2		2.5	V
I _{IH}	HIGH Input Current (2)	P0_0 to P0_7, P1_0 to P1_7, P2_0 to P2_7, P3_0 to P3_7, P4_0 to P4_7, P5_0 to P5_7, P6_0 to P6_7, P7_0 to P7_7, P8_0 to P8_7, P9_0 to P9_7, P10_0 to P10_7, P11_0 to P11_7, P12_0 to P12_7, P13_0 to P13_7, P14_0, P14_1, XIN, RESET, CNVSS, BYTE	V _I =5V			5.0	μA
I _{IL}	LOW Input Current (2)	P0_0 to P0_7, P1_0 to P1_7, P2_0 to P2_7, P3_0 to P3_7, P4_0 to P4_7, P5_0 to P5_7, P6_0 to P6_7, P7_0 to P7_7, P8_0 to P8_7, P9_0 to P9_7, P10_0 to P10_7, P11_0 to P11_7, P12_0 to P12_7, P13_0 to P13_7, P14_0, P14_1, XIN, RESET, CNVSS, BYTE	V _I =0V			-5.0	μA
R _{PULLUP}	Pull-Up Resistance (2)	P0_0 to P0_7, P1_0 to P1_7, P2_0 to P2_7, P3_0 to P3_7, P4_0 to P4_7, P5_0 to P5_7, P6_0 to P6_7, P7_2 to P7_7, P8_0 to P8_4, P8_6, P8_7, P9_0 to P9_7, P10_0 to P10_7, P11_0 to P11_7, P12_0 to P12_7, P13_0 to P13_7, P14_0, P14_1	V _I =0V	30	50	170	kΩ
R _{fXIN}	Feedback Resistance XIN				1.5		MΩ
R _{fXCIN}	Feedback Resistance XCIN				15		MΩ
V _{RAM}	RAM Retention Voltage		At stop mode	2.0			V

NOTES:

1. Referenced to V_{CC1}=V_{CC2}=4.0 to 5.5V, V_{SS} = 0V at T_{opr} = -40 to 85°C / -40 to 125°C, f(BCLK)=24MHz unless otherwise specified. T version = -40 to 85°C, V version = -40 to 125°C.
2. There is no external connections for port P1_0 to P1_7, P4_4 to P4_7, P7_2 to P7_5 and P9_1 in 80-pin version.

Table 5.58 Electrical Characteristics (2) (1)

Symbol	Parameter		Measuring Condition		Standard			Unit
					Min.	Typ.	Max.	
I _{cc}	Power Supply Current (V _{cc1} =V _{cc2} =4.0V to 5.5V)	In single-chip mode, the output pins are open and other pins are V _{ss}	Mask ROM	f(BCLK)=24MHz No division, PLL operation		14	20	mA
				No division, On-chip oscillation		1		mA
			Flash Memory	f(BCLK)=24MHz, No division, PLL operation		18	27	mA
				No division, On-chip oscillation		1.8		mA
			Flash Memory Program	f(BCLK)=10MHz, V _{cc1} =5.0V		15		mA
			Flash Memory Erase	f(BCLK)=10MHz, V _{cc1} =5.0V		25		mA
			Mask ROM	f(XCIN)=32kHz Low power dissipation mode, ROM (3)		25		μA
			Flash Memory	f(BCLK)=32kHz Low power dissipation mode, RAM (3)		25		μA
				f(BCLK)=32kHz Low power dissipation mode, Flash Memory (3)		420		μA
				On-chip oscillation, Wait mode		50		μA
			Mask ROM Flash Memory	f(BCLK)=32kHz Wait mode (2), Oscillation capability High		7.5		μA
				f(BCLK)=32kHz Wait mode (2), Oscillation capability Low		2.0		μA
				Stop mode T _{opr} =25°C		2.0	6.0	μA
				Stop mode T _{opr} =85°C			20	μA
Stop mode T _{opr} =125°C				TBD	μA			

NOTES:

1. Referenced to V_{cc1}=V_{cc2}=4.0 to 5.5V, V_{ss} = 0V at T_{opr} = -40 to 85°C / -40 to 125°C, f(BCLK)=24MHz unless otherwise specified. T version = -40 to 85°C, V version = -40 to 125°C.
2. With one timer operated using fC32.
3. This indicates the memory in which the program to be executed exists.

$$V_{CC1}=V_{CC2}=5V$$

Timing Requirements

($V_{CC1} = V_{CC2} = 5V$, $V_{SS} = 0V$, at $T_{opr} = -40$ to $85^{\circ}C$ (T version) / -40 to $125^{\circ}C$ (V version) unless otherwise specified)

Table 5.59 External Clock Input (XIN input)

Symbol	Parameter	Standard		Unit
		Min.	Max.	
t_c	External Clock Input Cycle Time	62.5		ns
$t_{w(H)}$	External Clock Input HIGH Pulse Width	25		ns
$t_{w(L)}$	External Clock Input LOW Pulse Width	25		ns
t_r	External Clock Rise Time		15	ns
t_f	External Clock Fall Time		15	ns

$$V_{CC1}=V_{CC2}=5V$$

Timing Requirements

($V_{CC1} = V_{CC2} = 5V$, $V_{SS} = 0V$, at $T_{opr} = -40$ to $85^{\circ}C$ (T version) / -40 to $125^{\circ}C$ (V version) unless otherwise specified)

Table 5.60 Timer A Input (Counter Input in Event Counter Mode)

Symbol	Parameter	Standard		Unit
		Min.	Max.	
$t_{c(TA)}$	TAiIN Input Cycle Time	100		ns
$t_{w(TAH)}$	TAiIN Input HIGH Pulse Width	40		ns
$t_{w(TAL)}$	TAiIN Input LOW Pulse Width	40		ns

Table 5.61 Timer A Input (Gating Input in Timer Mode)

Symbol	Parameter	Standard		Unit
		Min.	Max.	
$t_{c(TA)}$	TAiIN Input Cycle Time	400		ns
$t_{w(TAH)}$	TAiIN Input HIGH Pulse Width	200		ns
$t_{w(TAL)}$	TAiIN Input LOW Pulse Width	200		ns

Table 5.62 Timer A Input (External Trigger Input in One-shot Timer Mode)

Symbol	Parameter	Standard		Unit
		Min.	Max.	
$t_{c(TA)}$	TAiIN Input Cycle Time	200		ns
$t_{w(TAH)}$	TAiIN Input HIGH Pulse Width	100		ns
$t_{w(TAL)}$	TAiIN Input LOW Pulse Width	100		ns

Table 5.63 Timer A Input (External Trigger Input in Pulse Width Modulation Mode)

Symbol	Parameter	Standard		Unit
		Min.	Max.	
$t_{w(TAH)}$	TAiIN Input HIGH Pulse Width	100		ns
$t_{w(TAL)}$	TAiIN Input LOW Pulse Width	100		ns

Table 5.64 Timer A Input (Counter Increment/Decrement Input in Event Counter Mode)

Symbol	Parameter	Standard		Unit
		Min.	Max.	
$t_{c(UP)}$	TAiOUT Input Cycle Time	2000		ns
$t_{w(UPH)}$	TAiOUT Input HIGH Pulse Width	1000		ns
$t_{w(UPL)}$	TAiOUT Input LOW Pulse Width	1000		ns
$t_{su(UP-TIN)}$	TAiOUT Input Setup Time	400		ns
$t_{h(TIN-UP)}$	TAiOUT Input Hold Time	400		ns

Table 5.65 Timer A Input (Two-phase Pulse Input in Event Counter Mode)

Symbol	Parameter	Standard		Unit
		Min.	Max.	
$t_{c(TA)}$	TAiIN Input Cycle Time	800		ns
$t_{su(TAIN-TAOUT)}$	TAiOUT Input Setup Time	200		ns
$t_{su(TAOUT-TAIN)}$	TAiIN Input Setup Time	200		ns

$$V_{CC1}=V_{CC2}=5V$$

Timing Requirements

($V_{CC1} = V_{CC2} = 5V$, $V_{SS} = 0V$, at $T_{opr} = -40$ to $85^{\circ}C$ (T version) / -40 to $125^{\circ}C$ (V version) unless otherwise specified)

Table 5.66 Timer B Input (Counter Input in Event Counter Mode)

Symbol	Parameter	Standard		Unit
		Min.	Max.	
$t_{c(TB)}$	TBiIN Input Cycle Time (counted on one edge)	100		ns
$t_{w(TBH)}$	TBiIN Input HIGH Pulse Width (counted on one edge)	40		ns
$t_{w(TBL)}$	TBiIN Input LOW Pulse Width (counted on one edge)	40		ns
$t_{c(TB)}$	TBiIN Input Cycle Time (counted on both edges)	200		ns
$t_{w(TBH)}$	TBiIN Input HIGH Pulse Width (counted on both edges)	80		ns
$t_{w(TBL)}$	TBiIN Input LOW Pulse Width (counted on both edges)	80		ns

Table 5.67 Timer B Input (Pulse Period Measurement Mode)

Symbol	Parameter	Standard		Unit
		Min.	Max.	
$t_{c(TB)}$	TBiIN Input Cycle Time	400		ns
$t_{w(TBH)}$	TBiIN Input HIGH Pulse Width	200		ns
$t_{w(TBL)}$	TBiIN Input LOW Pulse Width	200		ns

Table 5.68 Timer B Input (Pulse Width Measurement Mode)

Symbol	Parameter	Standard		Unit
		Min.	Max.	
$t_{c(TB)}$	TBiIN Input Cycle Time	400		ns
$t_{w(TBH)}$	TBiIN Input HIGH Pulse Width	200		ns
$t_{w(TBL)}$	TBiIN Input LOW Pulse Width	200		ns

Table 5.69 A/D Trigger Input

Symbol	Parameter	Standard		Unit
		Min.	Max.	
$t_{c(AD)}$	\overline{ADTRG} Input Cycle Time	1000		ns
$t_{w(ADL)}$	\overline{ADTRG} input LOW Pulse Width	125		ns

Table 5.70 Serial Interface

Symbol	Parameter	Standard		Unit
		Min.	Max.	
$t_{c(CK)}$	CLKi Input Cycle Time	200		ns
$t_{w(CKH)}$	CLKi Input HIGH Pulse Width	100		ns
$t_{w(CKL)}$	CLKi Input LOW Pulse Width	100		ns
$t_{d(C-Q)}$	TXDi Output Delay Time		80	ns
$t_h(C-Q)$	TXDi Hold Time	0		ns
$t_{su(D-C)}$	RXD _i Input Setup Time	70		ns
$t_h(C-D)$	RXD _i Input Hold Time	90		ns

Table 5.71 External Interrupt \overline{INT}_i Input

Symbol	Parameter	Standard		Unit
		Min.	Max.	
$t_{w(INH)}$	\overline{INT}_i Input HIGH Pulse Width	250		ns
$t_{w(INL)}$	\overline{INT}_i Input LOW Pulse Width	250		ns

$$V_{CC1}=V_{CC2}=5V$$

Switching Characteristics

($V_{CC1} = V_{CC2} = 5V$, $V_{SS} = 0V$, at $T_{opr} = -40$ to $85^{\circ}C$ (T version) / -40 to $125^{\circ}C$ (V version) unless otherwise specified)

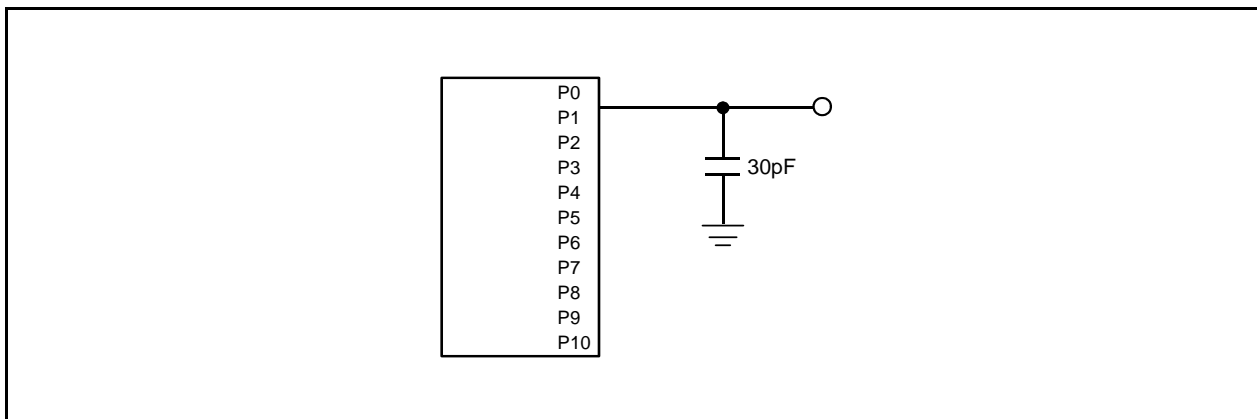


Figure 5.23 Ports P0 to P10 Measurement Circuit

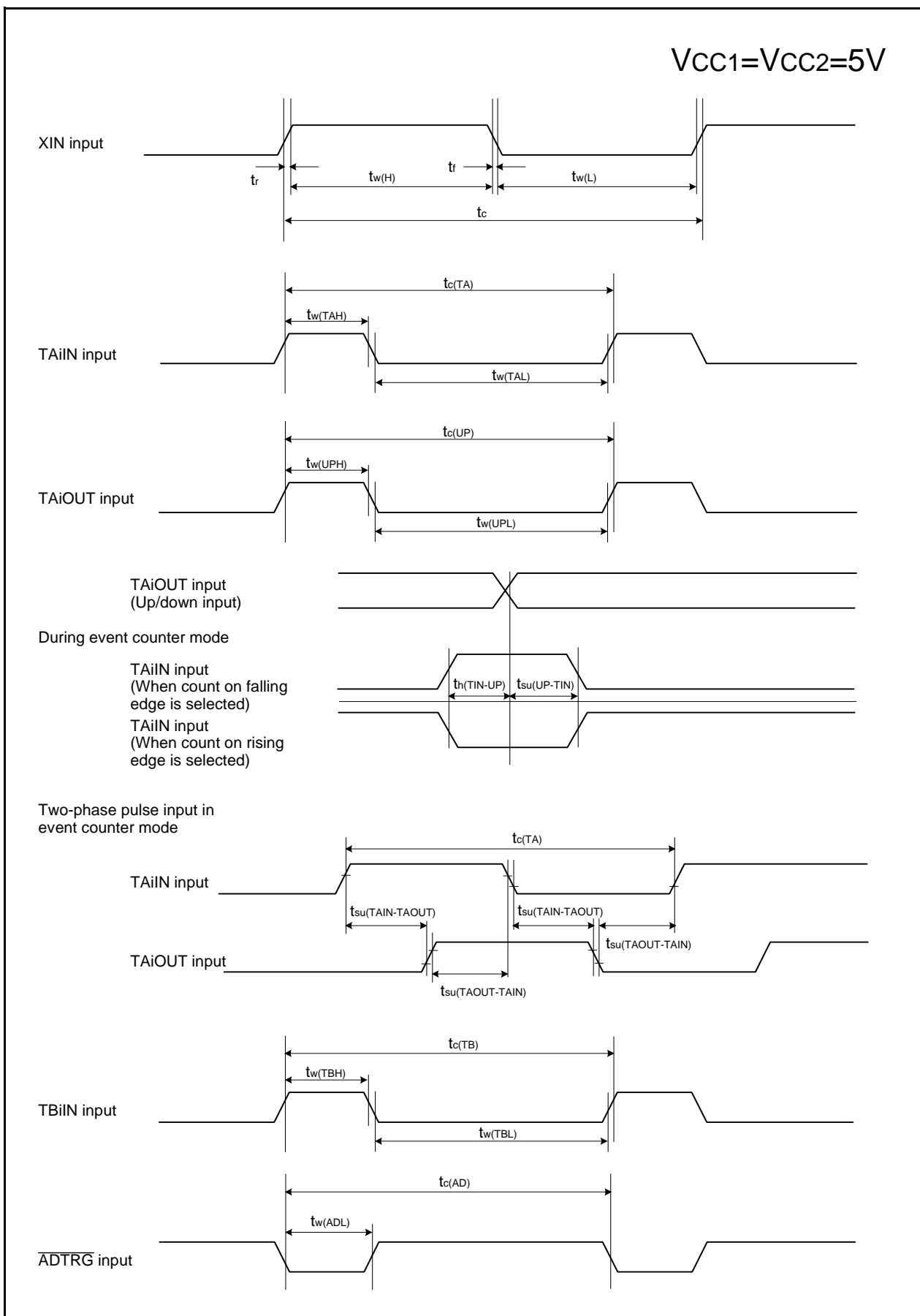
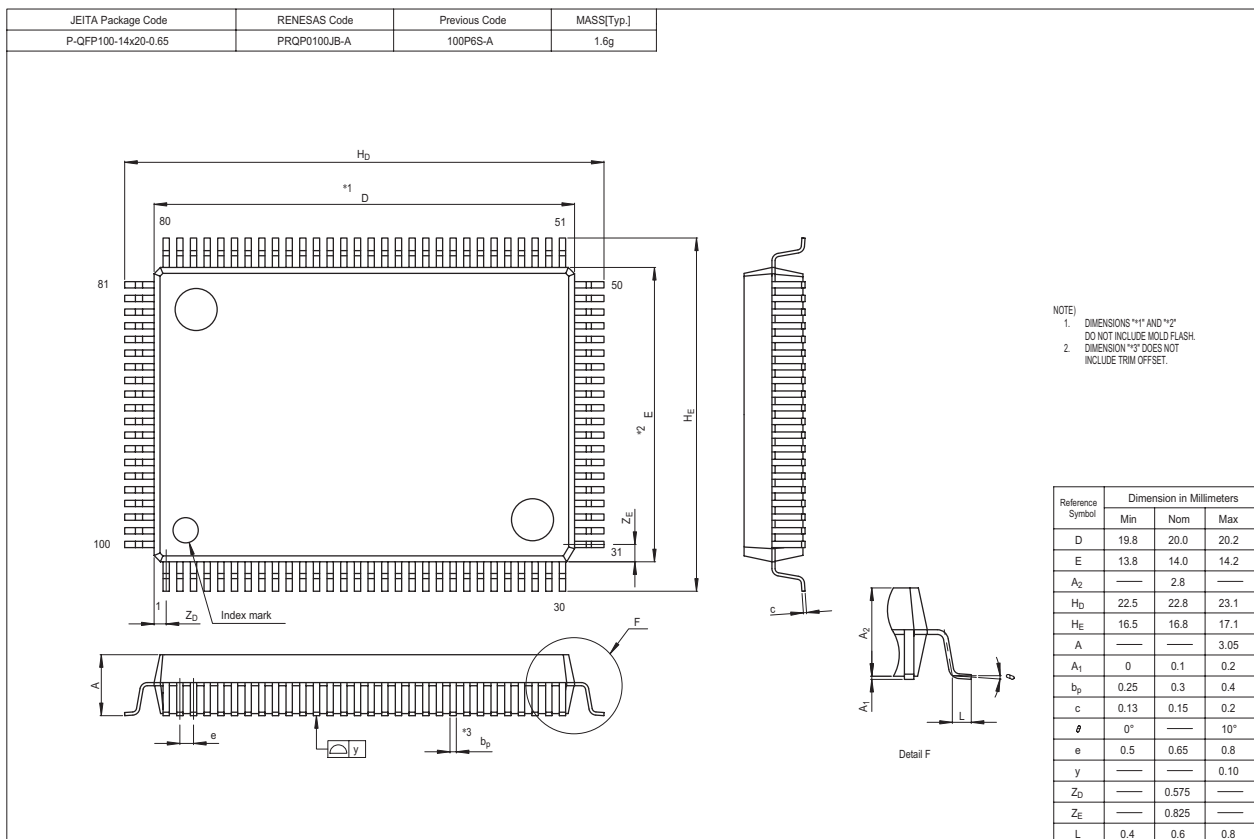
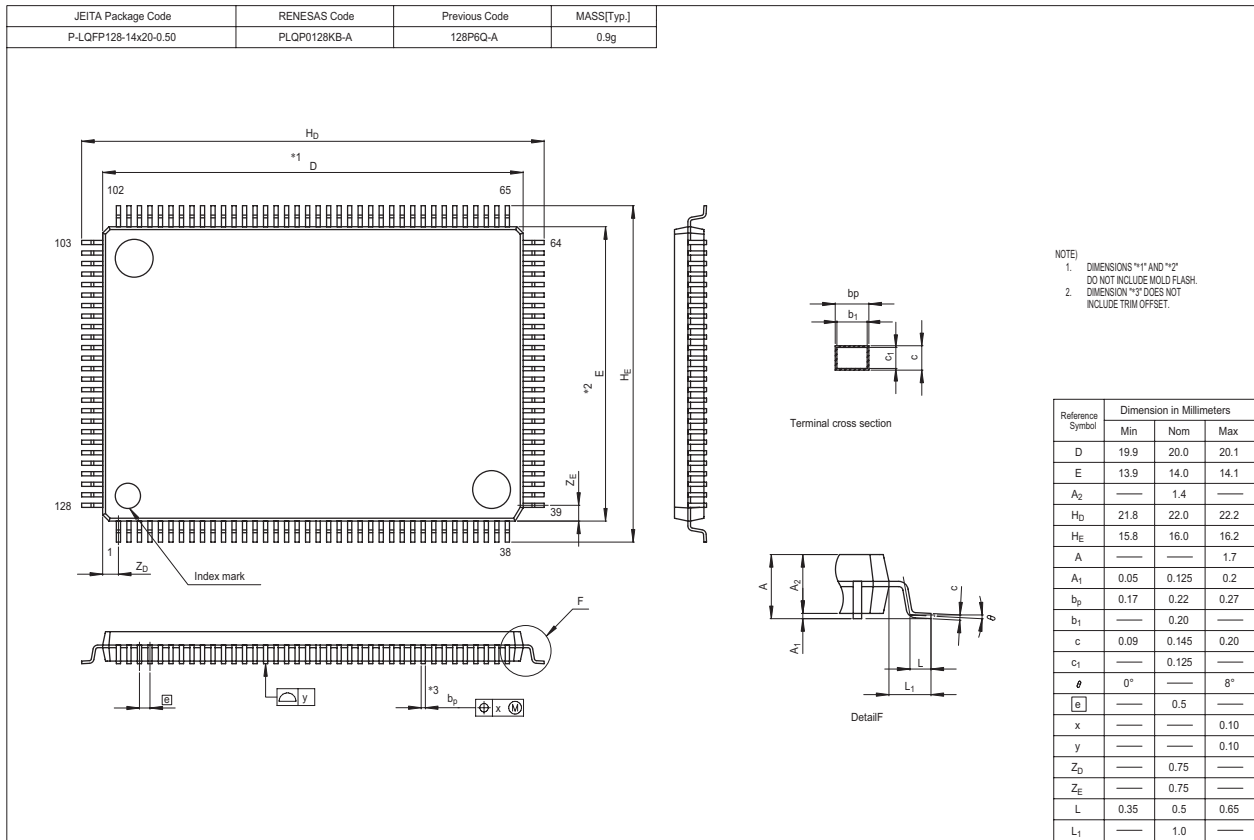


Figure 5.24 Timing Diagram (1)



Figure 5.25 Timing Diagram (2)

Appendix 1. Package Dimensions





REVISION HISTORY

M16C/62P Group (M16C/62P, M16C/62PT) Hardware Manual

Rev.	Date	Description	
		Page	Summary
1.10	May 28, 2003	1	Applications are partly revised.
		2	Table 1.1.1 is partly revised.
		4-5	Table 1.1.2 and 1.1.3 is partly revised. "Note 1" is partly revised.
		22	Table 1.5.3 is partly revised.
		23	Table 1.5.5 is partly revised. Table 1.5.6 is added.
		24	Table 1.5.9 is partly revised.
		30	Notes 1 and 2 in Table 1.5.26 is partly revised.
		31	Notes 1 in Table 1.5.27 is partly revised.
		30-31	Note 3 is added to "Data output hold time (refers to BCLK)" in Table 1.5.26 and 1.5.27.
		32	Note 4 is added to "th(ALE-AD)" in Table 1.5.28.
		30-32	Switching Characteristics is partly revised.
		36-39	th(WR-AD) and th(WR-DB) in Figure 1.5.5 to 1.5.8 is partly revised.
		40-41	th(ALE-AD), th(WR-CS), th(WR-DB) and th(WR-AD) in Figure 1.5.9 to 1.5.10 is partly revised.
		42	Note 2 is added to Table 1.5.29.
		47	Notes 1 and 2 in Table 1.5.45 is partly revised.
		48	Notes 1 in Table 1.5.46 is partly revised.
		47-48	Note 3 is added to "Data output hold time (refers to BCLK)" in Table 1.5.45 and 1.5.46.
		49	Note 4 is added to "th(ALE-AD)" in Table 1.5.47.
		47-48	Switching Characteristics is partly revised.
53-56	th(WR-AD) and th(WR-DB) in Figure 1.5.15 to 1.5.18 is partly revised.		
57-58	th(ALE-AD), th(WR-CS), th(WR-DB) and th(WR-AD) in Figure 1.5.19 to 1.5.20 is partly revised.		
2.00	Oct 29, 2003	-	Since high reliability version is added, a group name is revised. M16C/62 Group (M16C/62P) → M16C/62 Group (M16C/62P, M16C/62PT)
		2-4	Table 1.1 to 1.3 are revised. Note 3 is partly revised.
		2-4	Table 1.1 to 1.3 are revised. Note 3 is partly revised.
		6	Figure 1.2 Note5 is deleted.
		7-9	Table 1.4 to 1.7 Product List is partly revised.
		11	Table 1.8 and Figure 1.4 are added.
		12-15	Figure 1.5 to 1.9 ZP is added.
		17,19	Table 1.10 and 1.12 ZP is added to timer A.
		18,20	Table 1.11 and 1.13 VCC1 is added to VREF.
		30	Table 5.1 is revised.
31-32	Table 5.2 and 5.3 are revised.		

REVISION HISTORY

M16C/62P Group (M16C/62P, M16C/62PT) Hardware Manual

Rev.	Date	Description	
		Page	Summary
		33 34,74 36 38,55 41 41-43, 58-60 44 47-48 49-50 52 53 58 61 64-65 66-67 69 70-85	Table 5.4 A-D Conversion Characteristics is revised. Table 5.5 D-A Conversion Characteristics revised. Table 5.6 to 5.7 and table 5.54 to 5.55 are revised. Table 5.11 is revised. Table 5.14 and 5.33 HLDA output deley time is deleted. Figure 5.1 is partly revised. Table 5.27 to 5.29 and table 5.46 to 48 HLDA output deley time is added. Figure 5.2 Timing Diagram (1) XIN input is added. Figure 5.5 to 5.6 Read timing DB → DBi Figure 5.7 to 5.8 Write timing DB → DBi Figure 5.10 DB → DBi Table 5.30 is revised. Figure 5.11 is partly revised. Figure 5.12 Timing Diagram (1) XIN input is added. Figure 5.15 to 5.16 Read timing DB → DBi Figure 5.17 to 5.18 Write timing DB → DBi Figure 5.20 DB → DBi Electrical Characteristics (M16C/62PT) is added.
2.10	Nov 07, 2003	8-9 23 71 72	Table 1.5 to 1.7 Product List is partly revised. Note 1 is deleted. Table 3.1 is revised. Table 5.50 is revised. Table 5.51 is deleted.
2.11	Jan 06, 2004	16 17-18 31	Table 1.9 NOTE 3 VCC1 VCC2 → VCC1 > VCC2 Table 1.10 to 1.11 NOTE 1 VCC1 VCC2 → VCC1 > VCC2 Table 5.2 Power Supply Ripple Allowable Frequency Unit MHz → kHz
2.30	Sep 01, 2004	12 18, 20 19,21 24 25 33 34 35 37	Table 1.9 and Figure 1.5 are added. Table 1.11 to 1.13 are revised. Table 1.12 to 1.14 are revised. Figure 3.1 is partly revised. Note 3 is added. Note 6 is added. Table 5.3 is revised. Note 2 in Table 5.4 is added. Table 5.5 to 5.6 is partly revised. Table 5.8 is revised. Table 5.9 is revised. Table 5.11 is revised.

REVISION HISTORY

M16C/62P Group (M16C/62P, M16C/62PT) Hardware Manual

Rev.	Date	Description	
		Page	Summary
		40	Table 5.24 is partly revised.
		57	Table 5.43 is partly revised.
		70	Table 5.48 is partly revised.
		72	Table 5.50 is partly revised.
		73	Table 5.53 is partly revised.
		74	Table 5.55 is revised.
		76	Table 5.57 is partly revised.
		79	Table 5.69 is partly revised.
2.41	Jan 01, 2006	-	voltage down detection reset -> brown-out detection Reset
		2-4	Tables 1.1 to 1.3 Performance outline of M16C/62P group are partly revised.
		7	Table 1.4 Product List (1) is partly revised. Note 1 is added.
		8	Table 1.5 Product List (2) is partly revised. Note 1, 2 and 3 are added.
		9	Table 1.6 Product List (3) is partly revised. Note 1 and 2 are added.
		10	Table 1.7 Product List (4) is partly revised. Note 1 and 2 are added.
		11	Figure 1.3 Type No., Memory Size, Shows RAM capacity, and Package is partly revised
		12	Table 1.8 Product Code of Flash Memory version and ROMless version for M16C/62P is partly revised.
		13	Table 1.9 Product Code of Flash Memory version for M16C/62P is partly revised.
		14	Figure 1.6 Pin Configuration (Top View) is partly revised.
		15-17	Tables 1.10 to 1.12 Pin Characteristics for 128-Pin Package are added.
		18-19	Figure 1.7 and 1.8 Pin Configuration (Top View) are partly revised.
		20-21	Tables 1.13 to 1.14 Pin Characteristics for 100-Pin Package are added.
		22	Figure 1.9 Pin Configuration (Top View) is partly revised.
		23-24	Tables 1.15 to 1.16 Pin Characteristics for 80-Pin Package are added.
		25-29	Tables 1.17 to 1.21 are partly revised.
		34	Note 4 of Table 4.1 SFR Information is partly revised.
		43	Table 5.4 A/D Conversion Characteristics is partly revised.
		45	Table 5.6 Flash Memory Version Electrical Characteristics for 100 cycle products is partly revised. Table 5.7 Flash Memory Version Electrical Characteristics for 10,000 cycle products is partly revised.
		46	Table 5.8 Flash Memory Version Program / Erase Voltage and Read Operation Voltage Characteristics is partly revised. Table 5.9 Low Voltage Detection Circuit Electrical Characteristics is partly revised.

REVISION HISTORY

M16C/62P Group (M16C/62P, M16C/62PT) Hardware Manual

Rev.	Date	Description	
		Page	Summary
		47	Figure 5.1 Power Supply Circuit Timing Diagram is partly revised.
		48	Table 5.11 Electrical Characteristics (1) is partly deleted.
		49	Table 5.12 Electrical Characteristics (2) is partly revised.
		50	Note 1 of Table 5.13 External Clock Input (XIN input) is added.
		67	Notes 1 to 4 of Table 5.32 External Clock Input (XIN input) are added.
		85	Table 5.53 Flash Memory Version Electrical Characteristics for 100 cycle products is partly revised. Standard (Min.) is partly revised. Table 5.54 Flash Memory Version Electrical Characteristics for 10,000 cycle products is partly revised. Standard (Min.) is partly revised. Note 5 is revised. Table 23.55 Flash Memory Version Program / Erase Voltage and Read Operation Voltage Characteristics is partly revised.
		87	Table 5.57 Electrical Characteristics (1) is partly deleted.
		88	Table 5.58 Electrical Characteristics is partly revised.

Renesas Technology Corp. Sales Strategic Planning Div. Nippon Bldg., 2-6-2, Ohte-machi, Chiyoda-ku, Tokyo 100-0004, Japan

Keep safety first in your circuit designs!

1. Renesas Technology Corp. puts the maximum effort into making semiconductor products better and more reliable, but there is always the possibility that trouble may occur with them. Trouble with semiconductors may lead to personal injury, fire or property damage. Remember to give due consideration to safety when making your circuit designs, with appropriate measures such as (i) placement of substitutive, auxiliary circuits, (ii) use of nonflammable material or (iii) prevention against any malfunction or mishap.

Notes regarding these materials

1. These materials are intended as a reference to assist our customers in the selection of the Renesas Technology Corp. product best suited to the customer's application; they do not convey any license under any intellectual property rights, or any other rights, belonging to Renesas Technology Corp. or a third party.
2. Renesas Technology Corp. assumes no responsibility for any damage, or infringement of any third-party's rights, originating in the use of any product data, diagrams, charts, programs, algorithms, or circuit application examples contained in these materials.
3. All information contained in these materials, including product data, diagrams, charts, programs and algorithms represents information on products at the time of publication of these materials, and are subject to change by Renesas Technology Corp. without notice due to product improvements or other reasons. It is therefore recommended that customers contact Renesas Technology Corp. or an authorized Renesas Technology Corp. product distributor for the latest product information before purchasing a product listed herein.
The information described here may contain technical inaccuracies or typographical errors.
Renesas Technology Corp. assumes no responsibility for any damage, liability, or other loss rising from these inaccuracies or errors.
Please also pay attention to information published by Renesas Technology Corp. by various means, including the Renesas Technology Corp. Semiconductor home page (<http://www.renesas.com>).
4. When using any or all of the information contained in these materials, including product data, diagrams, charts, programs, and algorithms, please be sure to evaluate all information as a total system before making a final decision on the applicability of the information and products. Renesas Technology Corp. assumes no responsibility for any damage, liability or other loss resulting from the information contained herein.
5. Renesas Technology Corp. semiconductors are not designed or manufactured for use in a device or system that is used under circumstances in which human life is potentially at stake. Please contact Renesas Technology Corp. or an authorized Renesas Technology Corp. product distributor when considering the use of a product contained herein for any specific purposes, such as apparatus or systems for transportation, vehicular, medical, aerospace, nuclear, or undersea repeater use.
6. The prior written approval of Renesas Technology Corp. is necessary to reprint or reproduce in whole or in part these materials.
7. If these products or technologies are subject to the Japanese export control restrictions, they must be exported under a license from the Japanese government and cannot be imported into a country other than the approved destination.
Any diversion or reexport contrary to the export control laws and regulations of Japan and/or the country of destination is prohibited.
8. Please contact Renesas Technology Corp. for further details on these materials or the products contained therein.



RENESAS SALES OFFICES

<http://www.renesas.com>

Refer to "<http://www.renesas.com/en/network>" for the latest and detailed information.

Renesas Technology America, Inc.

450 Holger Way, San Jose, CA 95134-1368, U.S.A
Tel: <1> (408) 382-7500, Fax: <1> (408) 382-7501

Renesas Technology Europe Limited

Dukes Meadow, Millboard Road, Bourne End, Buckinghamshire, SL8 5FH, U.K.
Tel: <44> (1628) 585-100, Fax: <44> (1628) 585-900

Renesas Technology Hong Kong Ltd.

7th Floor, North Tower, World Finance Centre, Harbour City, 1 Canton Road, Tsimshatsui, Kowloon, Hong Kong
Tel: <852> 2265-6688, Fax: <852> 2730-6071

Renesas Technology Taiwan Co., Ltd.

10th Floor, No.99, Fushing North Road, Taipei, Taiwan
Tel: <886> (2) 2715-2888, Fax: <886> (2) 2713-2999

Renesas Technology (Shanghai) Co., Ltd.

Unit2607 Ruijing Building, No.205 Maoming Road (S), Shanghai 200020, China
Tel: <86> (21) 6472-1001, Fax: <86> (21) 6415-2952

Renesas Technology Singapore Pte. Ltd.

1 Harbour Front Avenue, #06-10, Keppel Bay Tower, Singapore 098632
Tel: <65> 6213-0200, Fax: <65> 6278-8001

Renesas Technology Korea Co., Ltd.

Kukje Center Bldg. 18th Fl., 191, 2-ka, Hangang-ro, Yongsan-ku, Seoul 140-702, Korea
Tel: <82> 2-796-3115, Fax: <82> 2-796-2145

Renesas Technology Malaysia Sdn. Bhd.


Unit 906, Block B, Menara Amcorp, Amcorp Trade Centre, No.18, Jalan Persiaran Barat, 46050 Petaling Jaya, Selangor Darul Ehsan, Malaysia
Tel: <603> 7955-9390, Fax: <603> 7955-9510

Looking for pricing, stock, or lifecycle information?

Click below to explore more details on WIN SOURCE:

-  [View M30622F8PGP#U3C on WIN SOURCE](#)
-  [Renesas Electronics America Information](#)

Optimize Your Supply Chain with WIN SOURCE Solutions

-  Global Sourcing Solution
-  Obsolete Management
-  Cost Control Management
-  Shortage Management
-  Alternative Solution
-  Excess Inventory Management