





## NPN SILICON HIGH FREQUENCY TRANSISTOR

### FEATURES

- **HIGH GAIN BANDWIDTH PRODUCT:**  $f_T = 8 \text{ GHz}$
- **LOW NOISE FIGURE:**  
1.2 dB at 1 GHz  
1.6 dB at 2 GHz
- **HIGH ASSOCIATED GAIN:**  
15 dB at 1 GHz  
12 dB at 2 GHz
- **LOW COST**

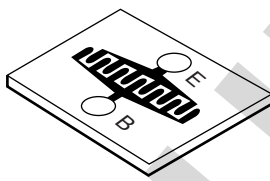
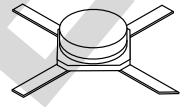
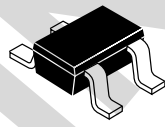
### DESCRIPTION

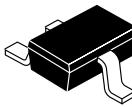
The NE681 series of NPN epitaxial silicon transistors are designed for low noise, high gain, low cost amplifier applications. Both the chip and micro-x versions are suitable for amplifier applications up to 4 GHz. The NE681 die is also available in six different low cost plastic surface mount package styles. NE681's unique device characteristics allow you to use a single matching point to simultaneously achieve both low noise and high gain.

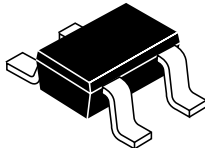
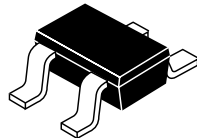
 00 (CHIP)	 35 (MICRO-X)
 18 (SOT 343 STYLE)	 19 (3 PIN ULTRA SUPER MINI MOLD)
 30 (SOT 323 STYLE)	 33 (SOT 23 STYLE)
 39 (SOT 143 STYLE)	 39R (SOT 143R STYLE)

**NOISE FIGURE, GAIN MSG  
AND MAG vs. FREQUENCY**

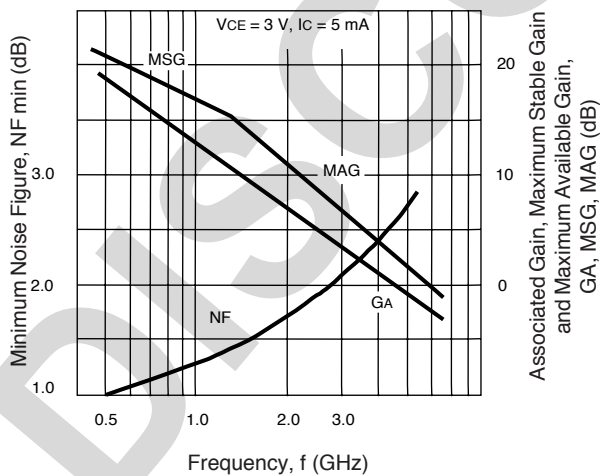

The information in this document is subject to change without notice. Before using this document, please confirm that this is the latest version.

**ELECTRICAL CHARACTERISTICS** (T<sub>A</sub> = 25°C)

PART NUMBER EIAJ <sup>1</sup> REGISTERED NUMBER PACKAGE OUTLINE			NE68100 00 (CHIP)			NE68118 2SC5012 18			NE68119 2SC5007 19			NE68130 2SC4227 30		
SYMBOLS	PARAMETERS AND CONDITIONS	UNITS	MIN	TYP	MAX	MIN	TYP	MAX	MIN	TYP	MAX	MIN	TYP	MAX
f <sub>T</sub>	Gain Bandwidth Product at V <sub>CE</sub> = 8 V, I <sub>C</sub> = 20 mA V <sub>CE</sub> = 3 V, I <sub>C</sub> = 7 mA	GHz GHz		9.0			9.0			7.0			7.0	
NF	Noise Figure at V <sub>CE</sub> = 8 V, I <sub>C</sub> = 7 mA, f = 1 GHz f = 2 GHz	dB dB		1.6	2.3		1.2	2.5		1.4 1.8			1.5 1.6	
GNF	Associated Gain at V <sub>CE</sub> = 8 V, I <sub>C</sub> = 7 mA, f = 1 GHz f = 2 GHz	dB dB		12			14			14 10			13.5 9	
IS <sub>21E</sub> <sup>2</sup>	Insertion Power Gain at V <sub>CE</sub> = 8 V, I <sub>C</sub> = 20 mA, f = 1 GHz f = 2 GHz	dB dB	9	17 11		13	15 9			14 8			13 7.5	
h <sub>FE</sub>	Forward Current Gain <sup>2</sup> at V <sub>CE</sub> = 8 V, I <sub>C</sub> = 20 mA V <sub>CE</sub> = 3 V, I <sub>C</sub> = 7 mA		50	100	250	50	100	250	80		160	40		240
I <sub>CBO</sub>	Collector Cutoff Current at V <sub>CB</sub> = 10 V, I <sub>E</sub> = 0 mA	μA			1.0			1.0			1.0			1.0
I <sub>EBO</sub>	Emitter Cutoff Current at V <sub>EB</sub> = 1 V, I <sub>C</sub> = 0 mA	μA			1.0			1.0			1.0			1.0
CRE <sup>3</sup>	Feedback Capacitance at V <sub>CB</sub> = 3 V, I <sub>E</sub> = 0 mA, f = 1 MHz V <sub>CB</sub> = 10 V, I <sub>E</sub> = 0 mA, f = 1 MHz	pF pF		0.2	0.7		0.25	0.8		0.45	0.9		0.45	0.9
R <sub>TH</sub> (J-A)	Thermal Resistance (Junction to Ambient)	°C/W			80			833			1000			833
P <sub>T</sub>	Total Power Dissipation	mW			600			150			100			150

**ELECTRICAL CHARACTERISTICS** (T<sub>A</sub> = 25°C)

PART NUMBER EIAJ <sup>1</sup> REGISTERED NUMBER PACKAGE OUTLINE			NE68133 2SC3583 33			NE68135 2SC3604 35			NE68139/39R 2SC4094 39			
SYMBOLS	PARAMETERS AND CONDITIONS	UNITS	MIN	TYP	MAX	MIN	TYP	MAX	MIN	TYP	MAX	
f <sub>T</sub>	Gain Bandwidth Product at V <sub>CE</sub> = 8 V, I <sub>C</sub> = 20 mA V <sub>CE</sub> = 3 V, I <sub>C</sub> = 7 mA	GHz GHz		9.0			9.0			9.0		
NF	Noise Figure at V <sub>CE</sub> = 8 V, I <sub>C</sub> = 7 mA, f = 1 GHz f = 2 GHz	dB dB		1.2	2					1.2	2	
GNF	Associated Gain at V <sub>CE</sub> = 8 V, I <sub>C</sub> = 7 mA, f = 1 GHz f = 2 GHz	dB dB		13						12		13.5
IS <sub>21E</sub> <sup>2</sup>	Insertion Power Gain at V <sub>CE</sub> = 8 V, I <sub>C</sub> = 20 mA, f = 1 GHz f = 2 GHz	dB dB		11	12.5 7		9	11				15 8.5
h <sub>FE</sub>	Forward Current Gain <sup>2</sup> at V <sub>CE</sub> = 8 V, I <sub>C</sub> = 20 mA V <sub>CE</sub> = 3 V, I <sub>C</sub> = 7 mA		50	100	250	50	100	250	50	100	200	
I <sub>CBO</sub>	Collector Cutoff Current at V <sub>CB</sub> = 10 V, I <sub>E</sub> = 0 mA	μA			1.0			1.0			1.0	
I <sub>EBO</sub>	Emitter Cutoff Current at V <sub>EB</sub> = 1 V, I <sub>C</sub> = 0 mA	μA			1.0			1.0			1.0	
CRE <sup>3</sup>	Feedback Capacitance at V <sub>CB</sub> = 10 V, I <sub>E</sub> = 0 mA, f = 1 MHz	pF		0.35	0.9			0.2	0.7		0.25	0.8
R <sub>TH</sub> (J-A)	Thermal Resistance (Junction to Ambient)	°C/W			625			590			625	
P <sub>T</sub>	Total Power Dissipation	mW			200			295			200	

Notes:

1. Electronic Industrial Association of Japan.
2. Pulsed (PW ≤ 350 ms, duty cycle ≤ 2 %).
3. The emitter terminal should be connected to the ground terminal of the 3 terminal capacitance bridge.

**ABSOLUTE MAXIMUM RATINGS<sup>1</sup>** (T<sub>A</sub> = 25°C)

SYMBOLS	PARAMETERS	UNITS	RATINGS
V <sub>CB0</sub>	Collector to Base Voltage	V	20
V <sub>CE0</sub>	Collector to Emitter Voltage	V	10
V <sub>EB0</sub>	Emitter to Base Voltage	V	1.5
I <sub>c</sub>	Collector Current	mA	65
T <sub>J</sub>	Operating Junction Temperature	°C	150 <sup>2</sup>
T <sub>STG</sub>	Storage Temperature	°C	-55 to +150 <sup>3</sup>

Notes:

1. Operation in excess of any one of these parameters may result in permanent damage.
2. T<sub>J</sub> for NE68135 and NE68100 is 200°C.
3. Maximum storage temperature for the NE68135 is -65 to +150°C.

**NE68119**

**TYPICAL NOISE PARAMETERS** (T<sub>A</sub> = 25°C)

FREQ. (MHz)	NF <sub>OPT</sub> (dB)	G <sub>A</sub> (dB)	Γ <sub>OPT</sub>		Rn/50
			MAG	ANG	
<b>V<sub>CE</sub> = 2.5 V, I<sub>c</sub> = 0.3 mA</b>					
500	1.24	9.26	0.73	42	1.70
800	1.67	6.95	0.74	72	1.01
1000	2.18	6.02	0.70	90	0.78
<b>V<sub>CE</sub> = 2.5 V, I<sub>c</sub> = 1 mA</b>					
500	0.97	13.86	0.66	43	0.46
800	1.19	9.12	0.59	48	0.35
1000	1.31	10.09	0.56	89	0.30
1500	1.71	7.99	0.50	131	0.16
<b>V<sub>CE</sub> = 2.5 V, I<sub>c</sub> = 3 mA</b>					
500	0.92	17.19	0.49	39	0.28
800	1.02	14.23	0.40	68	0.17
1000	1.11	12.78	0.38	87	0.14
1500	1.42	10.30	0.39	134	0.08
2000	1.82	8.24	0.36	165	0.11
<b>V<sub>CE</sub> = 3 V, I<sub>c</sub> = 5 mA</b>					
500	1.00	19.00	0.37	43	0.20
800	1.10	15.57	0.31	71	0.15
1000	1.19	13.91	0.30	89	0.13
1500	1.40	11.25	0.33	139	0.09
2000	1.70	9.08	0.32	166	0.11
2500	2.05	7.62	0.36	-163	0.13
<b>V<sub>CE</sub> = 8 V, I<sub>c</sub> = 7 mA</b>					
500	1.10	20.30	0.36	39	0.22
800	1.20	16.82	0.28	64	0.16
1000	1.30	15.10	0.28	81	0.14
1500	1.50	12.35	0.28	130	0.11
2000	1.77	10.21	0.28	158	0.12
2500	2.10	8.85	0.33	-166	0.14
3000	2.40	7.86	0.44	-141	0.16

**NE68100**

**TYPICAL NOISE PARAMETERS** (T<sub>A</sub> = 25°C)

FREQ. (MHz)	NF <sub>OPT</sub> (dB)	G <sub>A</sub> (dB)	Γ <sub>OPT</sub>		Rn/50
			MAG	ANG	
<b>V<sub>CE</sub> = 8 V, I<sub>c</sub> = 7 mA</b>					
500	1.3	26.42	0.20	91	0.20
1000	1.45	20.54	0.20	148	0.21
2000	2.1	14.41	0.22	178	0.51
4000	3.25	7.76	0.42	-115	0.85

**NE68130**

**TYPICAL NOISE PARAMETERS** (T<sub>A</sub> = 25°C)

FREQ. (MHz)	NF <sub>OPT</sub> (dB)	G <sub>A</sub> (dB)	Γ <sub>OPT</sub>		Rn/50
			MAG	ANG	
<b>V<sub>CE</sub> = 2.5 V, I<sub>c</sub> = 0.3 mA</b>					
500	1.48	10.23	0.74	43	1.35
800	1.90	10.15	0.72	79	0.92
1000	2.15	9.00	0.69	99	0.60
1500	2.70	4.46	0.66	126	0.38
<b>V<sub>CE</sub> = 2.5 V, I<sub>c</sub> = 1 mA</b>					
500	1.10	14.69	0.65	45	0.42
800	1.26	12.73	0.60	80	0.30
1000	1.40	11.29	0.56	99	0.24
1500	1.80	7.40	0.53	123	0.17
2000	2.22	6.14	0.47	166	0.12
2500	2.75	4.89	0.49	-166	0.08
<b>V<sub>CE</sub> = 2.5 V, I<sub>c</sub> = 3 mA</b>					
500	1.00	17.28	0.47	44	0.25
800	1.06	14.35	0.44	83	0.21
1000	1.16	12.69	0.43	100	0.17
1500	1.46	9.50	0.39	130	0.12
2000	1.80	7.70	0.35	177	0.11
2500	2.15	6.03	0.35	-177	0.09
<b>V<sub>CE</sub> = 8 V, I<sub>c</sub> = 7mA</b>					
500	1.30	20.34	0.29	50	0.27
1000	1.40	13.96	0.25	84	0.18
2000	1.80	8.56	0.25	155	0.16
3000	2.50	5.64	0.48	-167	0.10
4000	3.60	4.50	0.67	-135	0.20

**NE68135**

**TYPICAL NOISE PARAMETERS** (T<sub>A</sub> = 25°C)

FREQ. (MHz)	NF <sub>OPT</sub> (dB)	G <sub>A</sub> (dB)	Γ <sub>OPT</sub>		Rn/50
			MAG	ANG	
<b>V<sub>CE</sub> = 8 V, I<sub>c</sub> = 7 mA</b>					
1000	1.1	17.33	0.28	71	0.22
2000	1.6	13.60	0.37	160	0.15
4000	3.4	9.25	0.51	-139	0.27

NE68133

TYPICAL NOISE PARAMETERS (T<sub>A</sub> = 25°C)

FREQ. (MHz)	NF <sub>OPT</sub> (dB)	G <sub>A</sub> (dB)	Γ <sub>OPT</sub>		Rn/50
			MAG	ANG	
<b>V<sub>CE</sub> = 2.5 V, I<sub>C</sub> = 0.3 mA</b>					
500	1.21	12.45	0.75	47	1.15
800	1.69	7.72	0.74	72	0.97
1000	1.95	5.96	0.68	88	0.71
1500	2.52	3.12	0.63	122	0.34
<b>V<sub>CE</sub> = 2.5 V, I<sub>C</sub> = 1.0 mA</b>					
500	.92	14.52	0.68	47	0.42
800	1.20	10.57	0.63	70	0.34
1000	1.35	9.29	0.57	87	0.30
1500	1.71	6.53	0.50	120	0.17
2000	2.00	5.53	0.44	168	0.11
<b>V<sub>CE</sub> = 2.5 V, I<sub>C</sub> = 3 mA</b>					
500	0.86	16.37	0.54	47	0.24
800	1.00	12.41	0.51	67	0.20
1000	1.08	11.07	0.46	86	0.18
1500	1.25	8.61	0.36	128	0.12
2000	1.40	6.99	0.35	172	0.10

NE68139

TYPICAL NOISE PARAMETERS (T<sub>A</sub> = 25°C)

FREQ. (MHz)	NF <sub>OPT</sub> (dB)	G <sub>A</sub> (dB)	Γ <sub>OPT</sub>		Rn/50
			MAG	ANG	
<b>V<sub>CE</sub> = 2.5 V, I<sub>C</sub> = 0.3 mA</b>					
500	1.20	14.10	0.78	47	1.28
800	1.45	8.42	0.75	72	0.84
1000	1.67	8.37	0.68	95	0.56
<b>V<sub>CE</sub> = 2.5 V, I<sub>C</sub> = 1 mA</b>					
500	0.90	15.71	0.63	44	0.43
800	1.10	12.30	0.56	72	0.26
1000	1.26	11.66	0.53	98	0.20
1500	1.70	8.85	0.49	145	0.12
2000	2.20	7.12	0.57	178	0.07
<b>V<sub>CE</sub> = 2.5 V, I<sub>C</sub> = 3 mA</b>					
500	0.88	18.20	0.45	44	0.25
800	1.00	14.62	0.39	73	0.19
1000	1.08	13.29	0.37	99	0.16
1500	1.30	10.54	0.35	151	0.09
2000	1.80	8.60	0.43	-177	0.07
<b>V<sub>CE</sub> = 8 V, I<sub>C</sub> = 7 mA</b>					
500	1.15	20.50	0.26	42	0.17
1000	1.25	15.62	0.16	133	0.14
1500	1.4	12.49	0.20	176	0.09
2000	1.6	10.48	0.31	-165	0.14
3000	2.15	8.00	0.53	-123	0.48
4000	3.0	6.81	0.71	-101	0.90

TYPICAL PERFORMANCE CURVES (T<sub>A</sub> = 25°C)

FORWARD INSERTION GAIN AND MAXIMUM AVAILABLE GAIN vs. FREQUENCY

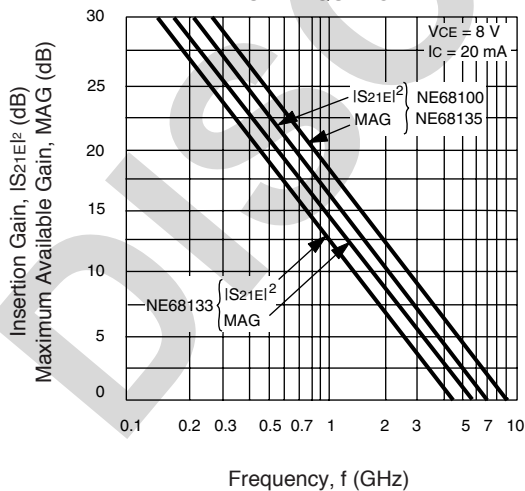

NE68100 & NE68135 INSERTION GAIN vs. COLLECTOR CURRENT

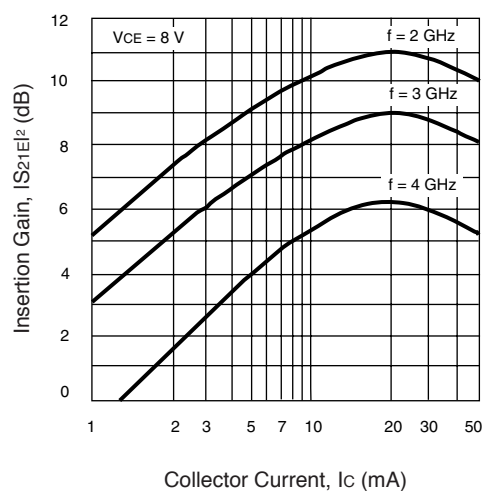

TYPICAL PERFORMANCE CURVES (TA = 25°C)

DC POWER DERATING CURVES

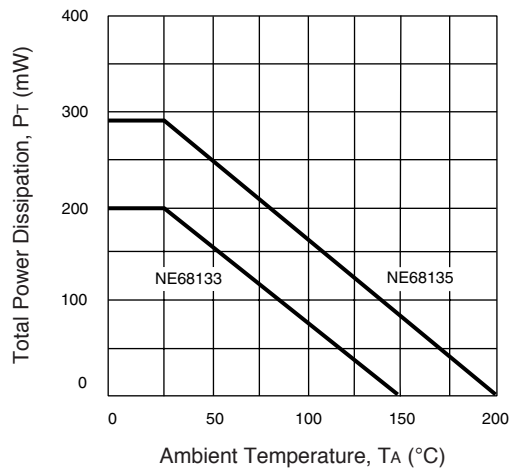

COLLECTOR TO BASE CAPACITANCE vs. COLLECTOR TO BASE VOLTAGE

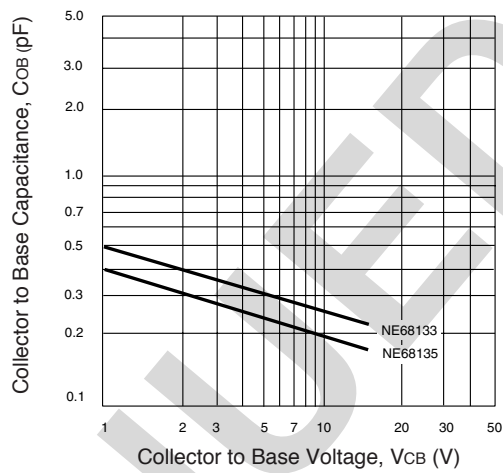

FORWARD CURRENT GAIN vs. COLLECTOR CURRENT

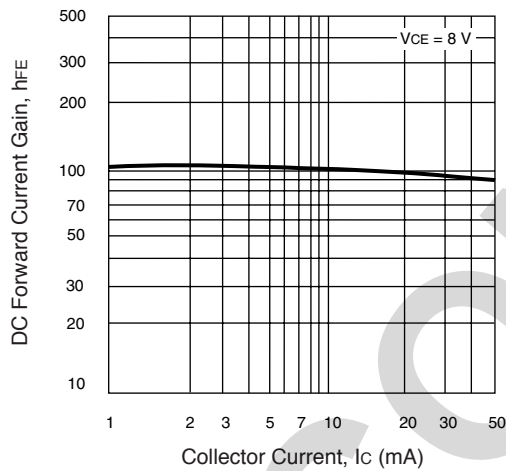

GAIN BANDWIDTH PRODUCT vs. COLLECTOR CURRENT

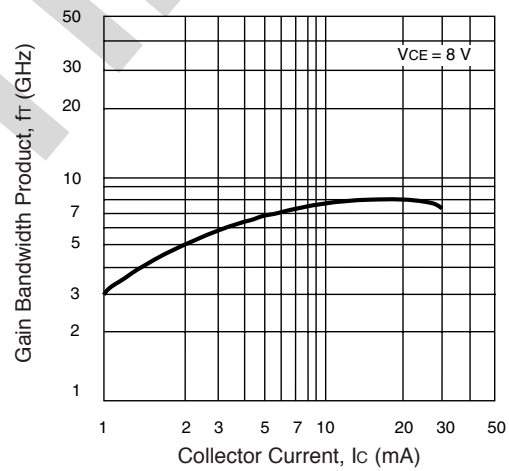

NE68133 NOISE FIGURE vs. COLLECTOR CURRENT

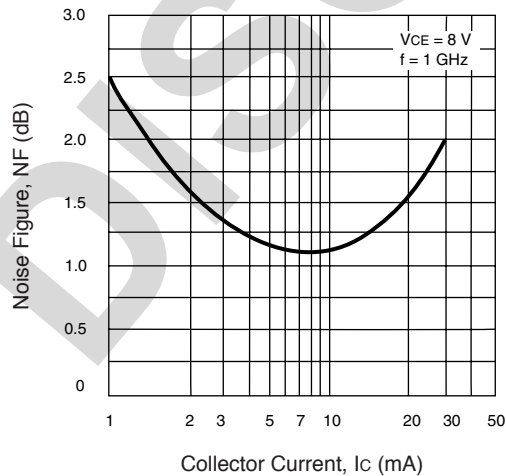

NE68100 & NE68135 NOISE FIGURE vs. COLLECTOR CURRENT

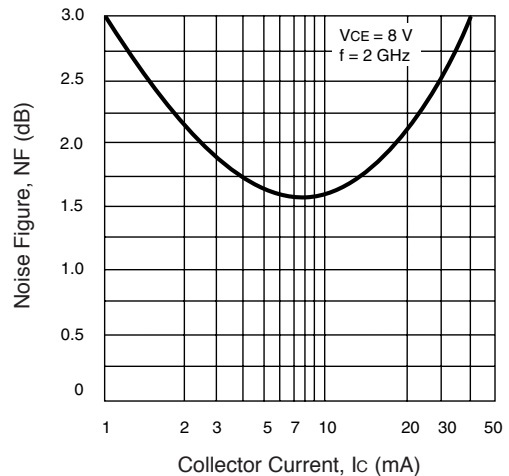

TYPICAL COMMON EMITTER SCATTERING PARAMETERS

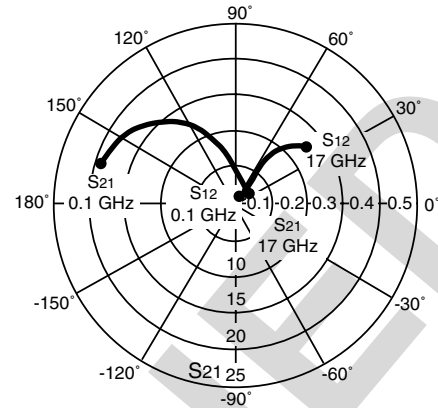
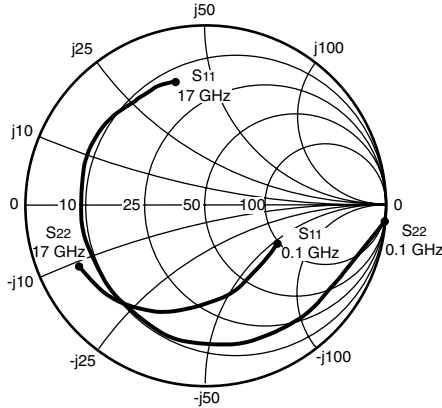

Coordinates in Ohms  
Frequency in GHz  
(VCE = 8 V, IC = 7 mA)

NE68100

VCE = 8 V, IC = 7 mA

FREQUENCY (MHz)	S11		S21		S12		S22		K	MAG <sup>1</sup> (dB)
	MAG	ANG	MAG	ANG	MAG	ANG	MAG	ANG		
100	0.827	-20.8	19.513	163.9	0.012	88.3	0.964	-7.0	0.03	32.1
200	0.809	-49.5	17.981	151.0	0.022	65.5	0.894	-16.8	0.13	29.1
500	0.742	-101.1	12.631	123.0	0.038	42.2	0.691	-27.4	0.28	25.2
1000	0.701	-139.2	7.498	101.5	0.047	36.7	0.536	-29.0	0.47	22.0
1500	0.689	-156.6	5.182	90.4	0.049	33.0	0.483	-28.6	0.71	20.2
2000	0.686	-167.2	3.959	82.0	0.053	35.0	0.461	-29.2	0.88	18.7
3000	0.687	179.8	2.687	69.7	0.061	45.9	0.447	-33.6	1.11	14.4
4000	0.693	172.2	2.048	59.1	0.071	48.7	0.449	-40.6	1.21	11.8
5000	0.699	166.6	1.662	49.8	0.081	53.2	0.454	-48.0	1.27	10.0
6000	0.708	162.1	1.431	41.1	0.096	57.0	0.473	-57.1	1.15	9.4
7000	0.717	157.0	1.250	31.7	0.116	56.6	0.490	-66.8	0.99	10.3
8000	0.721	151.7	1.105	23.3	0.125	56.9	0.519	-76.0	0.97	9.5
9000	0.725	145.5	0.989	14.2	0.146	55.9	0.549	-86.4	0.83	8.3
10000	0.726	137.6	0.868	5.9	0.169	54.9	0.582	-96.0	0.74	7.1
11000	0.724	131.2	0.773	-2.0	0.179	51.9	0.621	-104.8	0.71	6.4
12000	0.722	123.6	0.673	-9.7	0.192	49.0	0.663	-114.1	0.69	5.4

VCE = 8 V, IC = 20 mA

100	0.665	-47.0	38.130	154.1	0.011	90.0	0.885	-15.0	0.01	35.4
200	0.664	-85.3	31.089	135.9	0.017	70.3	0.753	-26.0	0.12	32.6
500	0.663	-135.8	16.975	108.9	0.025	45.4	0.504	-30.8	0.45	28.3
1000	0.663	-161.1	9.066	93.2	0.028	49.5	0.404	-27.0	0.82	25.1
1500	0.667	-171.7	6.113	84.9	0.036	49.6	0.377	-26.3	0.97	22.3
2000	0.669	-178.4	4.627	78.3	0.042	53.2	0.369	-26.6	1.10	18.5
3000	0.676	172.7	3.112	67.9	0.054	59.2	0.361	-31.6	1.25	14.6
4000	0.686	167.3	2.361	58.6	0.071	62.6	0.362	-38.5	1.21	12.5
5000	0.693	162.6	1.913	50.1	0.086	63.5	0.372	-45.8	1.19	10.8
6000	0.705	159.0	1.643	42.2	0.103	65.1	0.386	-55.5	1.08	10.3
7000	0.719	154.5	1.433	33.3	0.123	63.2	0.405	-65.0	0.94	10.7
8000	0.727	149.4	1.266	25.4	0.133	60.6	0.433	-74.2	0.91	9.8
9000	0.726	143.5	1.134	16.7	0.153	60.4	0.464	-84.5	0.84	8.7
10000	0.733	135.9	1.001	8.4	0.171	57.3	0.500	-94.4	0.76	7.7
11000	0.732	129.4	0.897	0.5	0.185	53.9	0.546	-103.2	0.71	6.9
12000	0.728	122.1	0.787	-7.1	0.197	51.8	0.587	-112.6	0.72	6.0

S-Parameters include bond wires.

BASE: Total 1 wire (s), 1 per bond pad, 0.0122" (309 μm) long each wire.

COLLECTOR: Total 1 wire (s), 1 per bond pad, 0.008" (203 μm) long each wire.

EMITTER: Total 2 wire (s), 1 per side, 0.0194" (494 μm) long each wire.

WIRE: 0.0007" (17.7 μm) dia., gold.

Note:

1. Gain Calculations:

$$MAG = \frac{|S_{21}|}{|S_{12}|} (K \pm \sqrt{K^2 - 1})$$

When  $K \leq 1$ , MAG is undefined and MSG values are used.  $MSG = \frac{|S_{21}|}{|S_{12}|}$ ,  $K = \frac{1 + |\Delta|^2 - |S_{11}|^2 - |S_{22}|^2}{2 |S_{12}| |S_{21}|}$ ,  $\Delta = S_{11} S_{22} - S_{21} S_{12}$

MAG = Maximum Available Gain

MSG = Maximum Stable Gain

TYPICAL COMMON EMITTER SCATTERING PARAMETERS

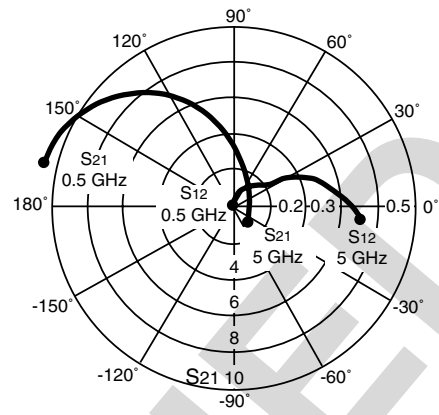
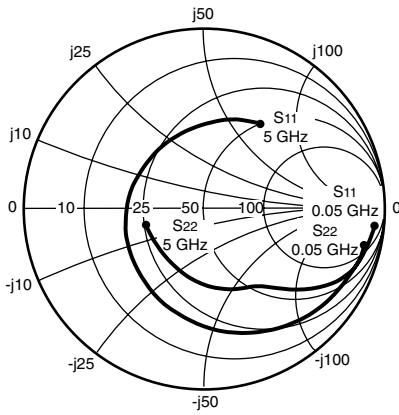

Coordinates in Ohms  
Frequency in GHz  
(V<sub>CE</sub> = 2.5 V, I<sub>C</sub> = 3 mA)

NE68119

V<sub>CE</sub> = 2.5 V, I<sub>C</sub> = 0.3 mA

FREQUENCY (MHz)	S <sub>11</sub>		S <sub>21</sub>		S <sub>12</sub>		S <sub>22</sub>		K	MAG <sup>1</sup> (dB)
	MAG	ANG	MAG	ANG	MAG	ANG	MAG	ANG		
50	0.995	-6.1	1.283	174.1	0.017	88.1	0.997	-1.1	0.02	18.8
100	0.992	-11.9	1.081	170.4	0.027	80.9	0.995	-4.5	0.06	16.0
200	0.981	-23.5	1.038	158.4	0.052	74.0	0.991	-9.3	0.11	13.0
300	0.967	-35.3	1.021	149.2	0.078	65.0	0.989	-14.3	0.15	11.2
400	0.950	-46.1	0.985	139.2	0.096	58.4	0.979	-18.2	0.20	10.1
500	0.929	-57.0	0.952	130.0	0.114	52.4	0.962	-22.5	0.23	9.2
600	0.915	-67.0	0.936	121.0	0.130	44.5	0.948	-26.4	0.30	8.6
700	0.892	-77.0	0.888	112.7	0.144	38.5	0.937	-30.1	0.33	7.9
800	0.874	-86.0	0.869	105.0	0.153	32.7	0.928	-33.9	0.36	7.5
900	0.853	-94.5	0.808	97.2	0.160	27.3	0.916	-37.1	0.42	7.0
1000	0.838	-102.9	0.784	90.6	0.165	21.8	0.908	-40.5	0.45	6.8
1500	0.770	-139.2	0.652	61.2	0.169	1.6	0.869	-54.5	0.66	5.9
2000	0.723	-170.6	0.564	39.0	0.146	-12.7	0.842	-66.5	0.95	5.9
3000	0.693	132.2	0.441	9.0	0.085	6.0	0.803	-91.2	1.98	1.5

V<sub>CE</sub> = 2.5 V, I<sub>C</sub> = 1.0 mA

50	0.979	-8.4	4.317	172.8	0.016	87.7	0.990	-1.3	0.04	24.3
100	0.965	-15.9	3.510	166.3	0.026	77.4	0.986	-7.5	0.10	21.3
200	0.944	-30.0	3.384	155.6	0.049	71.9	0.971	-13.0	0.09	18.4
300	0.915	-44.6	3.234	145.3	0.069	60.3	0.949	-19.4	0.15	16.7
400	0.877	-57.8	3.069	134.8	0.090	54.9	0.918	-24.6	0.17	15.3
500	0.836	-70.1	2.855	125.6	0.104	45.7	0.883	-29.1	0.25	14.4
600	0.802	-81.8	2.671	116.9	0.115	40.8	0.850	-33.4	0.28	13.7
700	0.770	-92.3	2.502	109.0	0.122	34.6	0.822	-37.2	0.33	13.1
800	0.741	-102.0	2.341	102.0	0.127	29.9	0.798	-40.6	0.38	12.7
900	0.714	-110.7	2.195	95.1	0.133	25.9	0.778	-43.4	0.43	12.2
1000	0.694	-118.7	2.041	89.4	0.135	21.6	0.762	-46.4	0.48	11.8
1500	0.616	-153.7	1.547	63.8	0.132	9.1	0.706	-58.1	0.75	10.7
2000	0.572	177.3	1.255	43.4	0.124	6.7	0.672	-68.2	1.07	8.4
3000	0.555	125.5	0.940	10.4	0.132	20.2	0.627	-89.7	1.41	4.7

V<sub>CE</sub> = 2.5 V, I<sub>C</sub> = 3 mA

50	0.937	-13.0	10.816	167.8	0.014	85.2	0.970	-5.3	0.08	28.9
100	0.904	-22.9	9.618	161.4	0.023	76.5	0.955	-12.0	0.10	26.2
200	0.839	-44.6	8.856	145.9	0.044	65.5	0.907	-21.5	0.16	23.0
300	0.771	-63.4	7.858	133.0	0.061	55.3	0.830	-29.5	0.25	21.1
400	0.699	-79.9	6.982	121.6	0.071	48.3	0.761	-35.9	0.32	19.9
500	0.642	-93.8	6.172	112.2	0.080	42.4	0.699	-39.7	0.41	18.9
600	0.598	-106.0	5.458	104.1	0.086	38.7	0.651	-43.3	0.48	18.0
700	0.564	-116.4	4.898	97.3	0.089	36.7	0.613	-46.0	0.55	17.4
800	0.534	-125.9	4.429	91.1	0.093	34.0	0.587	-48.2	0.62	16.8
900	0.511	-134.1	4.032	85.5	0.095	33.3	0.565	-50.1	0.69	16.3
1000	0.494	-141.6	3.696	80.6	0.099	32.1	0.549	-52.3	0.74	15.7
1500	0.438	-172.6	2.618	59.5	0.113	29.1	0.508	-59.9	0.99	13.6
2000	0.409	162.4	2.042	41.8	0.130	28.7	0.485	-67.6	1.15	9.6
3000	0.410	117.0	1.474	11.1	0.187	24.2	0.448	-85.5	1.16	6.5

See note on next page.

TYPICAL COMMON EMITTER SCATTERING PARAMETERS

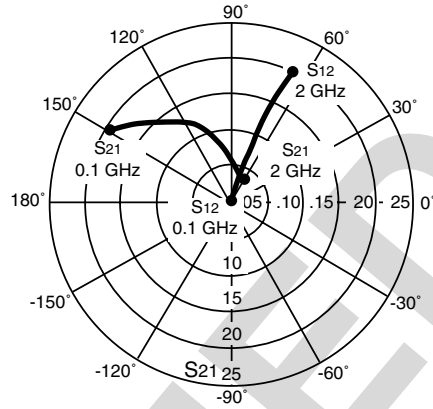
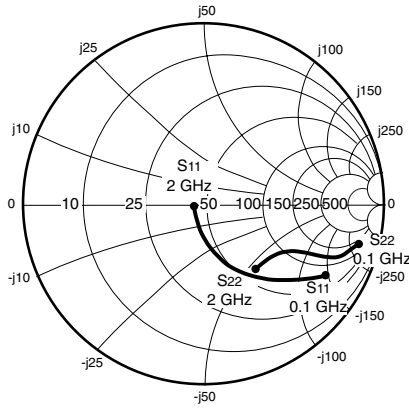

Coordinates in Ohms  
Frequency in GHz  
(V<sub>CE</sub> = 8 V, I<sub>c</sub> = 10 mA)

NE68133

V<sub>CE</sub> = 8 V, I<sub>c</sub> = 7 mA

FREQUENCY (MHz)	S <sub>11</sub>		S <sub>21</sub>		S <sub>12</sub>		S <sub>22</sub>		K	MAG <sup>1</sup> (dB)
	MAG	ANG	MAG	ANG	MAG	ANG	MAG	ANG		
100	0.802	-27.1	17.578	153.8	0.023	68.7	0.918	-12.7	0.37	28.8
200	0.639	-49.2	14.213	134.2	0.039	69.8	0.783	-19.9	0.46	25.6
500	0.344	-83.3	7.671	105.5	0.065	67.8	0.579	-21.5	0.81	20.7
1000	0.170	-113.4	4.126	86.7	0.109	73.5	0.491	-17.7	1.01	15.2
1500	0.115	-144.1	2.870	75.3	0.160	74.8	0.454	-17.8	1.05	11.2
2000	0.098	-176.3	2.254	66.2	0.212	74.7	0.438	-16.9	1.04	9.0
3000	0.137	137.6	1.669	53.2	0.313	73.2	0.409	-21.0	0.99	7.3

V<sub>CE</sub> = 8 V, I<sub>c</sub> = 10 mA

100	0.744	-31.7	21.212	148.4	0.017	57.9	0.896	-14.6	0.50	31.0
200	0.553	-54.5	16.031	127.9	0.037	69.0	0.737	-21.7	0.54	26.4
500	0.277	-87.1	8.093	102.0	0.061	72.6	0.540	-20.9	0.88	21.2
1000	0.134	-115.8	4.284	85.3	0.109	76.3	0.461	-17.0	1.04	14.7
1500	0.092	-146.2	2.981	75.2	0.165	75.9	0.430	-16.5	1.04	11.3
2000	0.079	180.0	2.350	66.5	0.217	75.2	0.413	-16.8	1.03	9.3
3000	0.122	134.2	1.736	53.9	0.320	73.7	0.380	-21.3	0.99	7.3

V<sub>CE</sub> = 8 V, I<sub>c</sub> = 20 mA

100	0.594	-43.3	29.285	138.1	0.013	61.2	0.792	-19.4	0.57	33.5
200	0.389	-66.3	19.280	117.5	0.035	73.1	0.614	-22.6	0.69	27.4
500	0.175	-95.5	8.683	96.1	0.057	74.0	0.481	-16.5	0.98	21.8
1000	0.089	-127.5	4.512	82.3	0.110	79.6	0.440	-13.2	1.03	15.1
1500	0.064	-160.8	3.078	73.3	0.167	78.9	0.416	-13.9	1.04	11.4
2000	0.070	167.0	2.406	64.9	0.221	74.9	0.404	-13.8	1.02	9.5
3000	0.120	132.5	1.774	53.1	0.322	72.4	0.379	-19.4	0.98	7.4

V<sub>CE</sub> = 8 V, I<sub>c</sub> = 30 mA

100	0.557	-46.9	30.197	135.2	0.017	65.9	0.836	-17.4	0.50	32.5
200	0.354	-70.7	19.196	115.1	0.029	73.4	0.664	-22.2	0.67	28.2
500	0.158	-100.5	8.499	94.8	0.059	77.7	0.503	-17.7	0.95	21.6
1000	0.080	-136.1	4.363	81.7	0.111	80.7	0.455	-14.3	1.03	14.9
1500	0.065	-175.0	3.009	72.7	0.167	80.1	0.428	-14.2	1.03	11.5
2000	0.076	156.0	2.348	65.0	0.219	77.1	0.415	-14.2	1.03	9.2
3000	0.127	128.4	1.742	53.0	0.325	74.2	0.387	-19.7	0.98	7.3

Note:

1. Gain Calculations:

$$MAG = \frac{|S_{21}|}{|S_{12}|} \left( K \pm \sqrt{K^2 - 1} \right). \text{ When } K \leq 1, \text{ MAG is undefined and MSG values are used. } MSG = \frac{|S_{21}|}{|S_{12}|}, K = \frac{1 + |\Delta|^2 - |S_{11}|^2 - |S_{22}|^2}{2 |S_{12}| |S_{21}|}, \Delta = S_{11} S_{22} - S_{21} S_{12}$$

MAG = Maximum Available Gain  
MSG = Maximum Stable Gain

TYPICAL COMMON EMITTER SCATTERING PARAMETERS

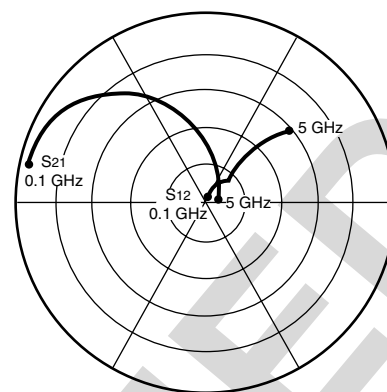
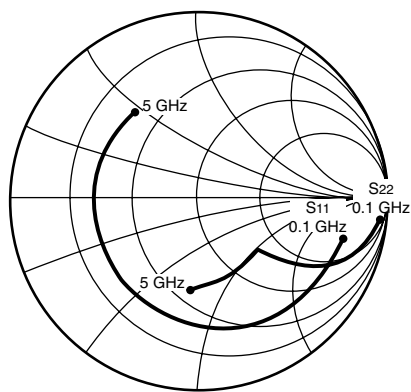

Coordinates in Ohms  
Frequency in GHz  
(VCE = 8 V, Ic = 10 mA)

NE68135

VCE = 8 V, Ic = 7 mA

FREQUENCY (MHz)	S11		S21		S12		S22		K	MAG <sup>1</sup> (dB)
	MAG	ANG	MAG	ANG	MAG	ANG	MAG	ANG		
100	.836	-26.1	18.427	160.4	.014	73.6	.959	-11.3	0.16	31.1
500	.659	-105.0	11.481	114.7	.041	44.3	.654	-33.2	0.38	24.4
1000	.585	-146.1	6.625	90.3	.051	38.3	.512	-38.5	0.68	21.1
1500	.557	-167.0	4.555	75.5	.058	39.3	.472	-43.1	0.93	18.9
2000	.562	-180.0	3.507	63.9	.068	41.3	.462	-49.4	1.02	16.4
3000	.561	159.6	2.413	43.4	.088	43.1	.468	-64.3	1.11	12.4
4000	.562	142.8	1.854	25.1	.113	41.9	.490	-80.4	1.07	10.6
5000	.563	127.0	1.516	8.0	.142	38.7	.522	-96.0	0.98	10.3

VCE = 8 V, Ic = 10 mA

100	.781	-32.1	24.097	157.2	.013	73.4	.937	-13.9	0.15	32.6
500	.609	-117.6	13.015	109.6	.036	44.6	.582	-35.2	0.47	25.6
1000	.558	-154.7	7.233	87.5	.045	43.2	.457	-38.5	0.79	22.0
1500	.540	-173.1	4.925	73.9	.055	45.8	.425	-42.6	1.00	19.4
2000	.547	175.3	3.778	62.9	.067	47.6	.420	-48.8	1.05	16.1
3000	.549	156.5	2.590	43.3	.091	47.4	.428	-63.7	1.09	12.7
4000	.551	140.6	1.990	25.5	.119	44.2	.452	-79.7	1.05	10.9
5000	.551	125.2	1.629	8.7	.149	39.4	.486	-95.2	0.96	10.4

VCE = 8 V, Ic = 20 mA

100	.654	-49.9	36.807	149.3	.012	67.4	.877	-19.2	0.21	35.0
500	.547	-139.7	14.980	101.5	.027	49.0	.475	-34.9	0.66	27.5
1000	.535	-168.1	7.916	83.2	.038	53.7	.392	-35.7	0.95	23.2
1500	.527	-177.7	5.328	71.3	.051	56.2	.375	-39.9	1.08	18.4
2000	.534	168.5	4.072	61.1	.065	56.6	.376	-46.5	1.09	16.2
3000	.541	151.9	2.780	42.7	.094	53.4	.389	-61.9	1.07	13.1
4000	.544	137.2	2.131	25.5	.124	47.8	.415	-78.1	1.01	11.6
5000	.544	122.7	1.745	9.0	.156	41.3	.451	-93.7	0.94	10.5

VCE = 8 V, Ic = 30 mA

100	.575	-64.1	43.452	144.0	.010	64.1	.831	-21.9	0.26	36.3
500	.539	-150.2	15.238	97.9	.023	52.7	.441	-32.3	0.77	28.2
1000	.537	-173.7	7.926	81.2	.036	58.9	.381	-32.9	1.01	22.7
1500	.532	173.7	5.318	69.9	.049	60.7	.370	-37.8	1.11	18.3
2000	.541	165.5	4.058	60.1	.064	60.2	.374	-44.9	1.09	16.1
3000	.549	149.8	2.767	41.9	.094	55.9	.390	-60.9	1.06	13.2
4000	.552	135.7	2.118	24.9	.125	49.8	.416	-77.4	1.00	12.1
5000	.553	121.2	1.731	8.5	.157	42.9	.453	-93.3	0.92	10.4

Note:

1. Gain Calculations:

$$MAG = \frac{|S_{21}|}{|S_{12}|} \left( K \pm \sqrt{K^2 - 1} \right). \text{ When } K \leq 1, \text{ MAG is undefined and MSG values are used. } MSG = \frac{|S_{21}|}{|S_{12}|}, K = \frac{1 + |\Delta|^2 - |S_{11}|^2 - |S_{22}|^2}{2 |S_{12}| |S_{21}|}, \Delta = S_{11} S_{22} - S_{21} S_{12}$$

MAG = Maximum Available Gain

MSG = Maximum Stable Gain

TYPICAL COMMON EMITTER SCATTERING PARAMETERS (TA = 25°C)

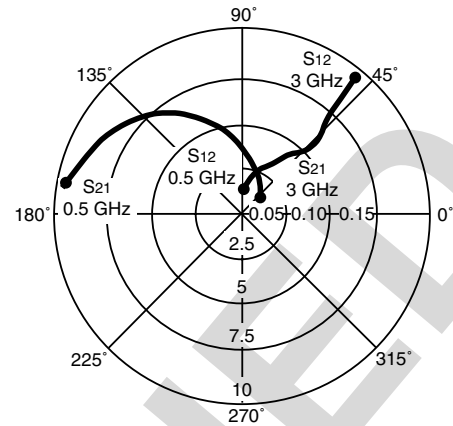
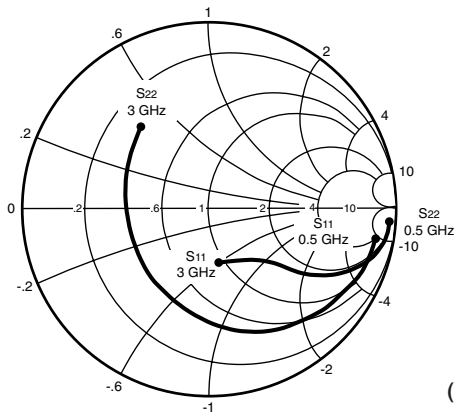

Coordinates in Ohms  
Frequency in GHz  
(VCE = 2.5 V, IC = 3 mA)

NE68139

VCE = 2.5 V, IC = 0.3 mA

FREQUENCY (MHz)	S11		S21		S12		S22		K	MAG <sup>1</sup> (dB)
	MAG	ANG	MAG	ANG	MAG	ANG	MAG	ANG		
50	0.996	-3.4	1.089	175.2	0.014	83.2	0.995	-1.1	0.13	18.9
100	0.995	-11.4	1.079	173.1	0.027	80.3	0.993	-2.7	0.06	16.0
200	0.990	-20.3	1.071	161.9	0.050	74.5	0.989	-5.7	0.16	13.3
300	0.973	-30.7	1.032	153.6	0.075	68.7	0.985	-8.7	0.19	11.4
400	0.953	-41.2	0.993	145.9	0.098	64.3	0.976	-11.4	0.19	10.1
500	0.931	-50.3	0.991	137.2	0.122	59.3	0.965	-13.8	0.25	9.1
600	0.909	-60.5	1.008	129.9	0.138	53.5	0.949	-16.4	0.28	8.6
800	0.862	-79.9	0.908	114.3	0.167	42.7	0.918	-21.0	0.37	7.4
1000	0.819	-98.5	0.871	101.2	0.184	33.4	0.888	-25.0	0.45	6.8
1500	0.744	-140.0	0.729	72.2	0.192	14.1	0.828	-35.2	0.66	5.8
2000	0.732	-173.0	0.632	51.7	0.155	3.4	0.802	-46.3	0.85	5.0
3000	0.762	142.1	0.438	28.5	0.089	8.4	0.770	-76.7	1.62	2.3

VCE = 2.5 V, IC = 1.0 mA

50	0.985	-6.8	3.763	175.3	0.016	86.4	0.989	-2.8	0.01	23.7
100	0.971	-14.8	3.648	171.0	0.029	82.4	0.980	-4.8	0.01	21.0
200	0.942	-27.5	3.497	159.1	0.050	74.3	0.963	-9.5	0.10	18.4
300	0.914	-40.4	3.346	149.4	0.070	65.4	0.946	-13.9	0.17	16.8
400	0.876	-53.8	3.184	140.6	0.092	58.7	0.916	-17.8	0.20	15.4
500	0.828	-65.2	3.043	131.8	0.106	53.8	0.884	-20.9	0.25	14.6
600	0.790	-76.9	2.880	124.1	0.119	47.7	0.845	-24.1	0.30	13.8
800	0.715	-98.4	2.516	109.8	0.137	38.9	0.778	-28.6	0.40	12.6
1000	0.663	-117.6	2.237	98.4	0.145	32.3	0.726	-31.9	0.49	11.9
1500	0.596	-157.8	1.686	74.8	0.145	23.5	0.631	-39.8	0.75	10.7
2000	0.600	173.8	1.346	56.9	0.130	24.6	0.583	-48.9	1.04	8.9
3000	0.660	136.9	0.941	30.9	0.144	47.4	0.538	-75.9	1.21	5.4

VCE = 2.5 V, IC = 3 mA

50	0.916	-10.7	10.426	172.1	0.015	84.7	0.975	-4.6	0.07	28.4
100	0.895	-23.5	9.954	164.8	0.027	79.0	0.972	-9.6	0.05	25.7
200	0.829	-42.0	9.011	148.6	0.046	67.6	0.910	-18.1	0.19	22.9
300	0.755	-60.3	8.067	136.2	0.061	57.7	0.826	-24.5	0.29	21.2
400	0.694	-76.4	7.165	125.8	0.074	52.4	0.754	-29.3	0.35	19.9
500	0.619	-90.0	6.329	117.1	0.083	49.8	0.690	-32.3	0.43	18.8
600	0.574	-103.0	5.660	109.8	0.089	46.7	0.634	-34.4	0.50	18.0
800	0.500	-125.0	4.558	97.8	0.099	43.3	0.552	-37.1	0.65	16.6
1000	0.470	-143.4	3.815	88.7	0.106	42.0	0.496	-38.6	0.77	15.6
1500	0.453	-178.4	2.684	70.7	0.123	43.6	0.412	-43.3	0.99	13.4
2000	0.481	159.4	2.078	56.4	0.141	47.3	0.362	-51.3	1.11	9.7
3000	0.567	130.6	1.442	34.1	0.197	49.7	0.302	-78.6	1.08	6.9

Note:

1. Gain Calculations:

$$MAG = \frac{|S_{21}|}{|S_{12}|} (K \pm \sqrt{K^2 - 1})$$

When  $K \leq 1$ , MAG is undefined and MSG values are used.  $MSG = \frac{|S_{21}|}{|S_{12}|}$ ,  $K = \frac{1 + |\Delta|^2 - |S_{11}|^2 - |S_{22}|^2}{2 |S_{12}| |S_{21}|}$ ,  $\Delta = S_{11} S_{22} - S_{21} S_{12}$

MAG = Maximum Available Gain

MSG = Maximum Stable Gain

TYPICAL COMMON EMITTER SCATTERING PARAMETERS (TA = 25°C)

NE68139

VCE = 8 V, IC = 7 mA

FREQUENCY (MHz)	S11		S21		S12		S22		K	MAG <sup>1</sup> (dB)
	MAG	ANG	MAG	ANG	MAG	ANG	MAG	ANG		
100	0.764	-28	17.806	156	0.002	53	0.944	-12	0.91	39.5
200	0.675	-55	15.233	138	0.008	70	0.855	-19	0.54	32.8
300	0.569	-76	12.659	126	0.018	61	0.734	-22	0.69	28.5
400	0.481	-94	10.620	116	0.025	59	0.698	-25	0.74	26.3
500	0.432	-110	8.886	107	0.035	59	0.602	-24	0.86	24.0
600	0.398	-120	7.696	102	0.043	58	0.589	-24	0.86	22.5
700	0.374	-133	6.888	97	0.046	59	0.530	-26	0.99	21.8
800	0.354	-141	6.073	93	0.056	59	0.522	-25	0.97	20.4
900	0.339	-152	5.422	88	0.055	60	0.493	-28	1.13	17.7
1000	0.332	-159	4.963	85	0.066	61	0.493	-25	1.05	17.4
1100	0.333	-166	4.576	81	0.069	62	0.488	-28	1.08	16.5
1200	0.343	-174	4.264	78	0.076	62	0.457	-27	1.09	15.7
1300	0.332	180	3.912	76	0.080	63	0.467	-29	1.12	14.8
1400	0.343	173	3.656	73	0.089	63	0.449	-29	1.09	14.3
1500	0.348	171	3.433	71	0.098	66	0.447	-29	1.06	13.9
2000	0.414	150	2.656	56	0.129	60	0.388	-40	1.04	11.9
3000	0.502	126	1.829	38	0.192	60	0.323	-63	1.00	9.8
4000	0.595	110	1.426	17	0.256	50	0.302	-95	0.88	7.5
5000	0.650	97	1.119	1	0.317	44	0.343	-126	0.83	5.5

Note:

1. Gain Calculations:

$$MAG = \frac{|S_{21}|}{|S_{12}|} (K \pm \sqrt{K^2 - 1})$$

. When  $K \leq 1$ , MAG is undefined and MSG values are used.  $MSG = \frac{|S_{21}|}{|S_{12}|}$ ,  $K = \frac{1 + |\Delta|^2 - |S_{11}|^2 - |S_{22}|^2}{2 |S_{12}| |S_{21}|}$ ,  $\Delta = S_{11} S_{22} - S_{21} S_{12}$

MAG = Maximum Available Gain

MSG = Maximum Stable Gain

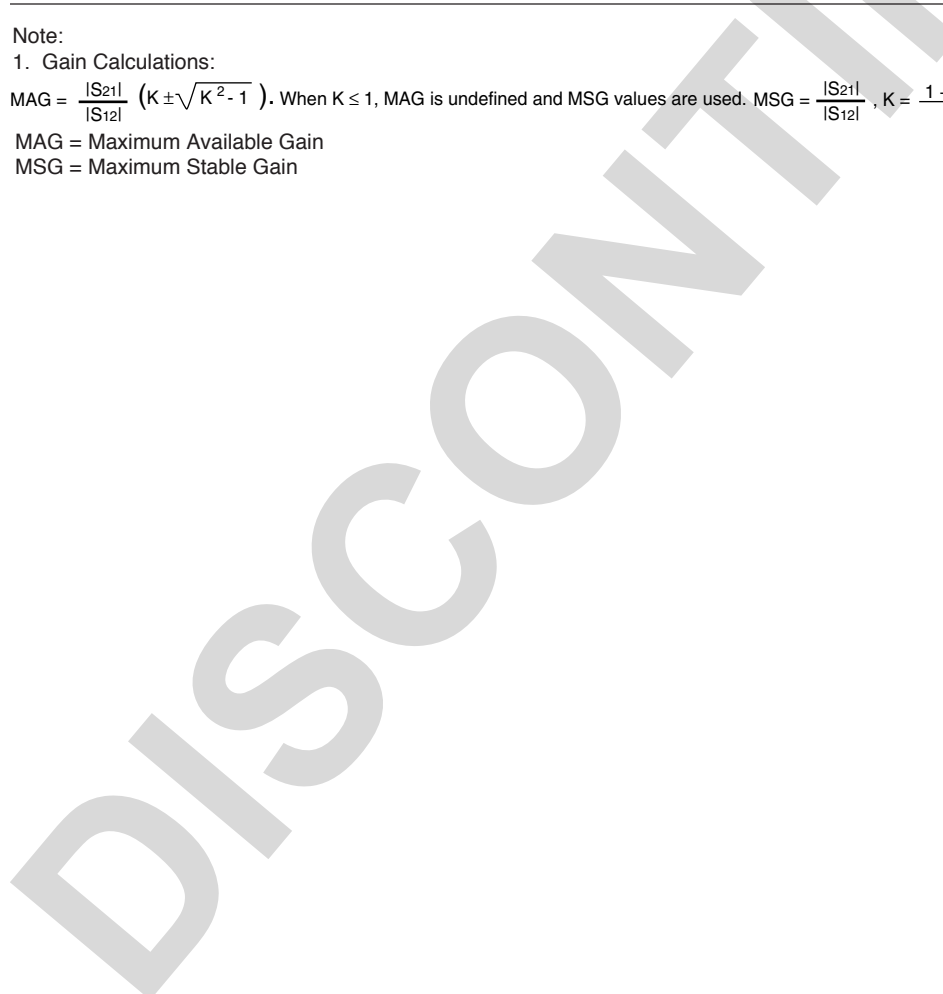

NE68118 NONLINEAR MODEL

SCHEMATIC

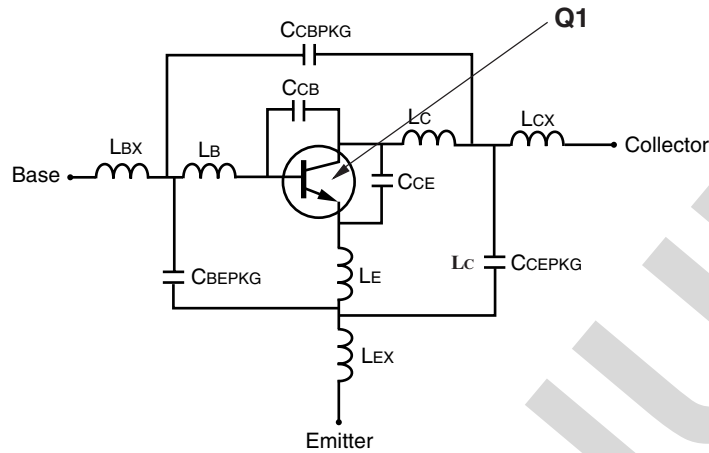

BJT NONLINEAR MODEL PARAMETERS(1)

Parameters	Q1	Parameters	Q1
IS	2.7e-16	MJC	0.56
BF	185	XCJC	0
NF	1.02	CJS	0
VAF	15	VJS	0.75
IKF	0.055	MJS	0
ISE	1.77e-11	FC	0.5
NE	2.1	TF	14e-12
BR	1	XTF	3
NR	1	VTF	25
VAR	Infinity	ITF	0.1
IKR	Infinity	PTF	0
ISC	0	TR	0.3e-9
NC	2	EG	1.11
RE	0.6	XTB	0
RB	12	XTI	3
RBM	3.7	KF	0
IRB	1.2e-5	AF	1
RC	8		
CJE	1.2e-12		
VJE	0.77		
MJE	0.5		
CJC	0.8e-12		
VJC	0.27		

(1) Gummel-Poon Model

UNITS

Parameter	Units
time	seconds
capacitance	farads
inductance	henries
resistance	ohms
voltage	volts
current	amps

ADDITIONAL PARAMETERS

Parameters	68118
CGB	0.07e-12
CCE	0.01e-12
LB	1.16e-9
LC	1.54e-9
LE	0.83e-9
CGBPKG	0.09e-12
CCEPKG	0.51e-12
CBEPKG	0.25e-12
LBX	0.18e-9
LCX	0.8e-9
LEX	0.09e-9

MODEL RANGE

Frequency: 0.05 to 5.0 GHz  
 Bias: V<sub>CE</sub> = 2.5 V to 8.0 V, I<sub>c</sub> = 3 mA to 10 mA  
 Date: 5/29/96

Note:

1. This nonlinear model utilized the latest data available. See our Design Parameter Library at [www.cel.com](http://www.cel.com) for this data.

NE68119 NONLINEAR MODEL

SCHEMATIC

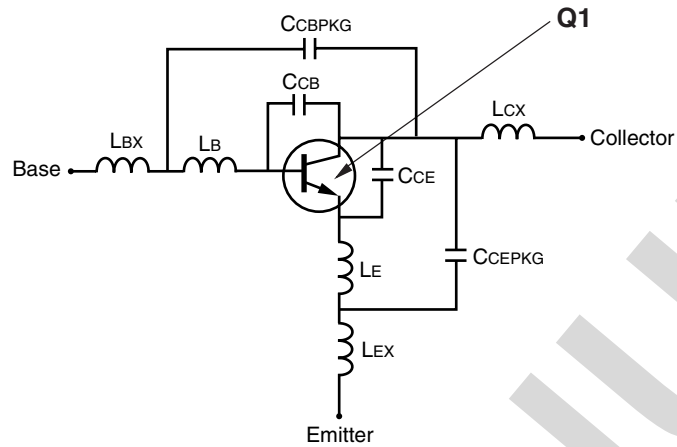

BJT NONLINEAR MODEL PARAMETERS<sup>(1)</sup>

Parameters	Q1	Parameters	Q1
IS	2.7e-16	MJC	0.56
BF	185.0	XCJC	0
NF	1.02	CJS	0
VAF	15.0	VJS	0.75
IKF	0.055	MJS	0
ISE	1.77e-11	FC	0.5
NE	2.1	TF	14.0e-12
BR	1	XTF	3
NR	1	VTF	25
VAR	Infinity	ITF	0.1
IKR	Infinity	PTF	0
ISC	0	TR	0.3e-9
NC	2	EG	1.11
RE	0.6	XTB	0
RB	12	XTI	3
RBM	3.7	KF	0
IRB	1.2e-5	AF	1
RC	8		
CJE	1.2e-12		
VJE	0.77		
MJE	0.5		
CJC	0.8e-12		
VJC	0.27		

UNITS

Parameter	Units
time	seconds
capacitance	farads
inductance	henries
resistance	ohms
voltage	volts
current	amps

ADDITIONAL PARAMETERS

Parameters	68119
CCB	0.07e-12
CCE	0.01e-12
LB	1.13e-9
LE	0.85e-9
CCEPKG	0.18e-12
CCEPKG	0.21e-12
LBX	0.19e-9
LCX	0.19e-9
LEX	0.19e-9

MODEL RANGE

Frequency: 0.05 to 3.0 GHz  
 Bias: VCE = 2.5 V to 8.0 V, IC = 0.3 mA to 10 mA

(1) Gummel-Poon Model

NE68130 NONLINEAR MODEL

SCHEMATIC

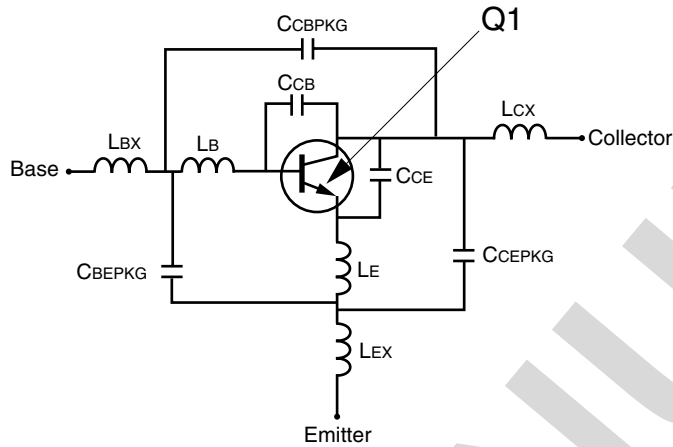

BJT NONLINEAR MODEL PARAMETERS <sup>(1)</sup>

Parameters	Q1	Parameters	Q1
IS	2.7e-16	MJC	0.56
BF	185	XCJC	0
NF	1.02	CJS	0
VAF	15	VJS	0.75
IKF	0.055	MJS	0
ISE	1.77e-11	FC	0.5
NE	2.1	TF	14e-12
BR	1	XTF	3
NR	1	VTF	25
VAR	Infinity	ITF	0.1
IKR	Infinity	PTF	0
ISC	0	TR	0.3e-9
NC	2	EG	1.11
RE	0.6	XTB	0
RB	12	XTI	3
RBM	3.7	KF	0
IRB	1.2e-5	AF	1
RC	8		
CJE	1.2e-12		
VJE	0.77		
MJE	0.5		
CJC	0.8e-12		
VJC	0.27		

(1) Gummel-Poon Model

UNITS

Parameter	Units
time	seconds
capacitance	farads
inductance	henries
resistance	ohms
voltage	volts
current	amps

ADDITIONAL PARAMETERS

Parameters	68130
CCB	0.07e-12
CCE	0.01e-12
LB	0.52e-9
LE	1.18e-9
CCBPKG	0.12e-12
CCEPKG	0.16e-12
CBEPKG	0.04e-12
LBX	0.2e-9
LCX	0.8e-9
LEX	0.2e-9

MODEL RANGE

Frequency: 0.05 to 3.0 GHz  
 Bias:  $V_{CE} = 2.5 \text{ V to } 8 \text{ V}$ ,  $I_c = 0.3 \text{ mA to } 10 \text{ mA}$   
 Date: 10/11/96

Note:

This nonlinear model utilized the latest data available. See our Design Parameter Library at [www.cel.com](http://www.cel.com) for this data.

NE68133 NONLINEAR MODEL

SCHEMATIC

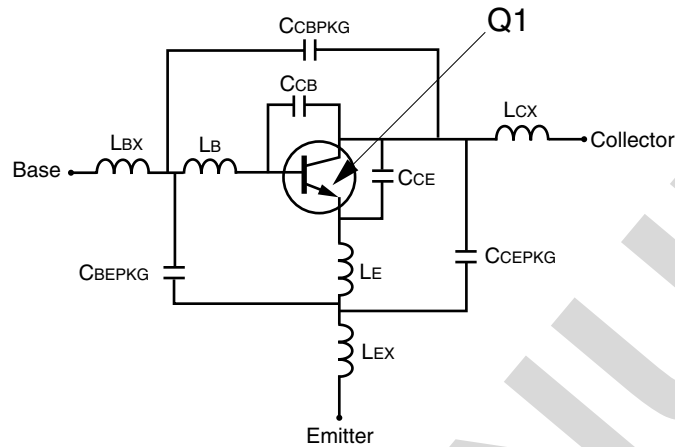

BJT NONLINEAR MODEL PARAMETERS (1)

Parameters	Q1	Parameters	Q1
IS	2.7e-16	MJC	0.56
BF	185	XCJC	0
NF	1.02	CJS	0
VAF	15	VJS	0.75
IKF	0.055	MJS	0
ISE	1.77e-11	FC	0.5
NE	2.1	TF	14e-12
BR	1	XTF	3
NR	1	VTF	25
VAR	Infinity	ITF	0.1
IKR	Infinity	PTF	0
ISC	0	TR	0.3e-9
NC	2	EG	1.11
RE	0.6	XTB	0
RB	12	XTI	3
RBM	3.7	KF	0
IRB	1.2e-5	AF	1
RC	8		
CJE	1.2e-12		
VJE	0.77		
MJE	0.5		
CJC	0.8e-12		
VJC	0.27		

(1) Gummel-Poon Model

UNITS

Parameter	Units
time	seconds
capacitance	farads
inductance	henries
resistance	ohms
voltage	volts
current	amps

ADDITIONAL PARAMETERS

Parameters	68133
CCB	0.07e-12
CCE	0.01e-12
LB	0.9e-9
LE	1.2e-9
CCBPKG	0.2e-12
CCEPKG	0.2e-12
CBEPKG	0.01e-12
LBX	0.3e-9
LCX	0.6e-9
LEX	0.3e-9

MODEL RANGE

Frequency: 0.1 to 8.0 GHz  
 Bias: VCE = 1 V to 8 V, IC = 1 mA to 30 mA  
 Date: 7/97

Note:

This nonlinear model utilized the latest data available. See our Design Parameter Library at [www.cel.com](http://www.cel.com) for this data.

NE68135 NONLINEAR MODEL

SCHEMATIC

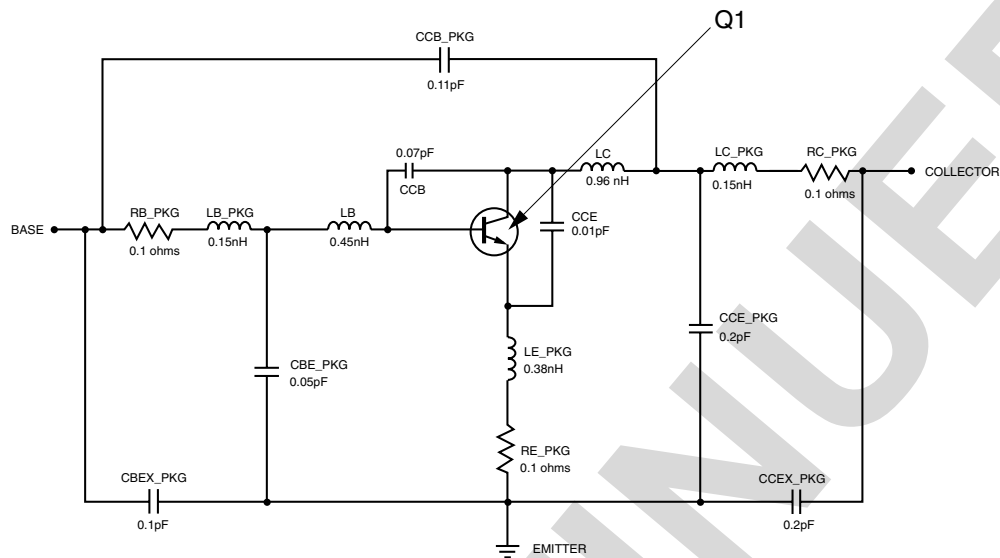

BJT NONLINEAR MODEL PARAMETERS (1)

Parameters	Q1	Parameters	Q1
IS	2.7e-16	MJC	0.56
BF	185.0	XCJC	0
NF	1.02	CJS	0
VAF	15.0	VJS	0.75
IKF	0.055	MJS	0
ISE	1.77e-11	FC	0.5
NE	2.1	TF	14e-12
BR	1	XTF	3
NR	1	VTF	25
VAR	Infinity	ITF	0.1
IKR	Infinity	PTF	0
ISC	0	TR	0.3e-9
NC	2	EG	1.11
RE	0.6	XTB	0
RB	12	XTI	3
RBM	3.7	KF	0
IRB	1.2e-5	AF	1
RC	8		
CJE	1.2e-12		
VJE	0.77		
MJE	0.5		
CJC	0.8e-12		
VJC	0.27		

UNITS

Parameter	Units
time	seconds
capacitance	farads
inductance	henries
resistance	ohms
voltage	volts
current	amps

MODEL RANGE

Frequency: 0.05 to 5.0 GHz  
 Bias: V<sub>CE</sub> = 8.0 V, I<sub>c</sub> = 7 mA to 30 mA  
 Date: 11/1/96

(1) Gummel-Poon Model

NE68139 NONLINEAR MODEL

SCHEMATIC

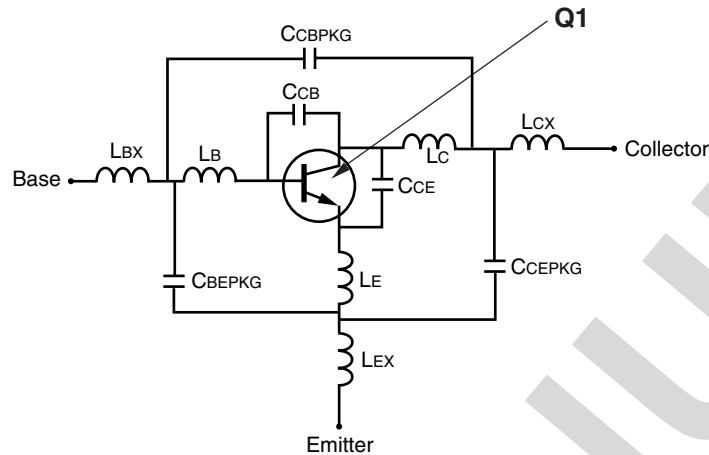

BJT NONLINEAR MODEL PARAMETERS(1)

Parameters	Q1	Parameters	Q1
IS	2.7e-16	MJC	0.56
BF	185.0	XCJC	0
NF	1.02	CJS	0
VAF	15.0	VJS	0.750
IKF	0.055	MJS	0
ISE	1.77e-11	FC	0.50
NE	2.1	TF	14.0e-12
BR	1.0	XTF	3.0
NR	1.0	VTF	25.0
VAR	Infinity	ITF	0.1
IKR	Infinity	PTF	0
ISC	0	TR	0.3e-9
NC	2.0	EG	1.11
RE	0.6	XTB	0
RB	12.0	XTI	3.0
RBM	3.7	KF	0
IRB	1.2e-5	AF	1.0
RC	8.0		
CJE	1.2e-12		
VJE	0.77		
MJE	0.50		
CJC	0.8e-12		
VJC	0.27		

(1) Gummel-Poon Model

UNITS

Parameter	Units
time	seconds
capacitance	farads
inductance	henries
resistance	ohms
voltage	volts
current	amps

ADDITIONAL PARAMETERS

Parameters	68139
CCB	0.07e-12
CCE	0.01e-12
LB	0.88e-9
LC	0.79e-9
LE	0.7e-9
CCBPKG	0.165e-12
CCEPKG	0.165e-12
CBEPKG	0.01e-12
LBX	0.39e-9
LCX	0.39e-9
LEX	0.2e-9

MODEL RANGE

Frequency: 0.1 to 3.0 GHz  
 Bias: VCE = 2.5 V to 8.0 V, IC = 0.3 mA to 7 mA  
 Date: 6/17/96

**OUTLINE DIMENSIONS** (Units in mm)

**NE68100 (CHIP)**  
(Chip Thickness: 160 μm)

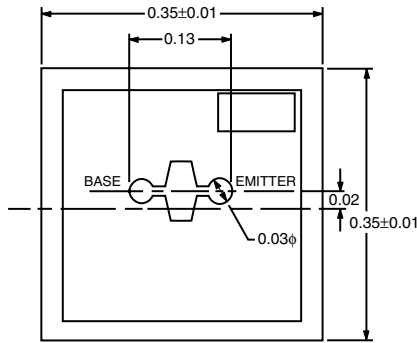

**PACKAGE OUTLINE 18**

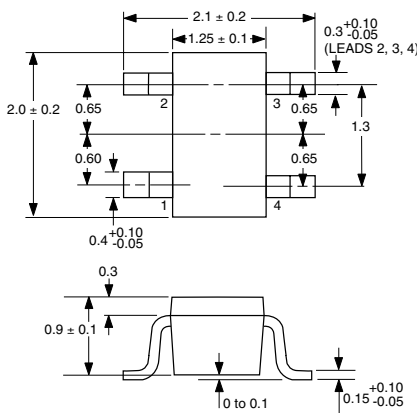

**PIN CONNECTIONS**

- 1. Collector
- 2. Emitter
- 3. Base
- 4. Emitter

**PACKAGE OUTLINE 18**  
**RECOMMENDED P.C.B. LAYOUT**

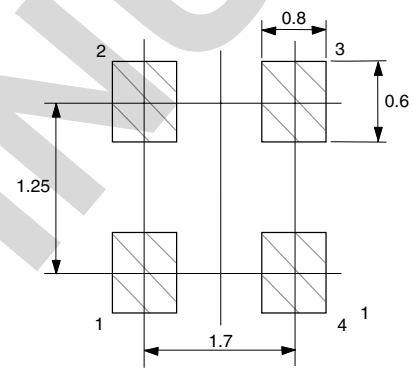

**PACKAGE OUTLINE 19**

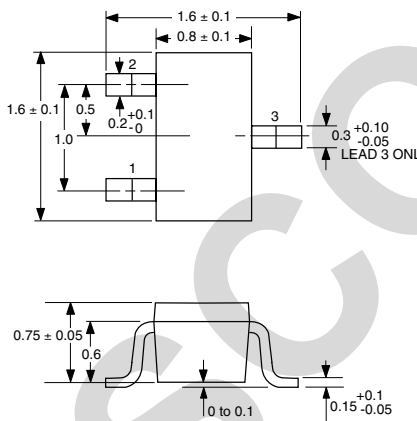

**PIN CONNECTIONS**

- 1. Emitter
- 2. Base
- 3. Collector

**PACKAGE OUTLINE 19**  
**RECOMMENDED P.C.B. LAYOUT**

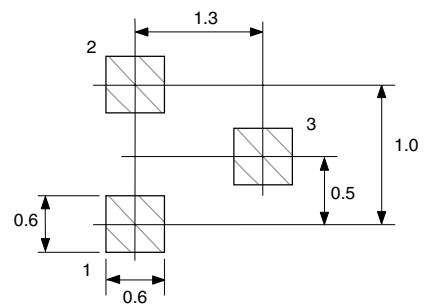

**PACKAGE OUTLINE 30**

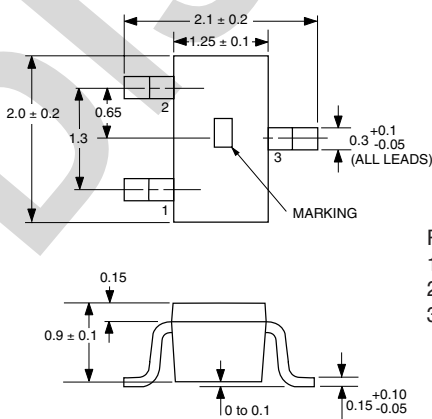

**PIN CONNECTIONS**

- 1. Emitter
- 2. Base
- 3. Collector

**PACKAGE OUTLINE 30**  
**RECOMMENDED P.C.B. LAYOUT**

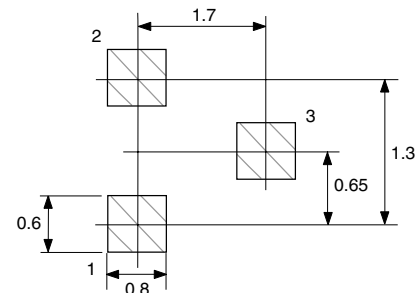

**OUTLINE DIMENSIONS** (Units in mm)

**PACKAGE OUTLINE 33**  
(SOT-23)

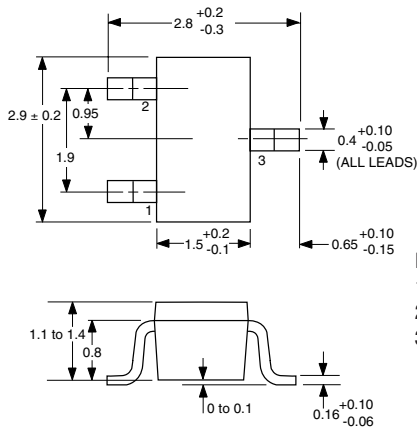

**PIN CONNECTIONS**  
1. Emitter  
2. Base  
3. Collector

**PACKAGE OUTLINE 33**  
**RECOMMENDED P.C.B. LAYOUT**

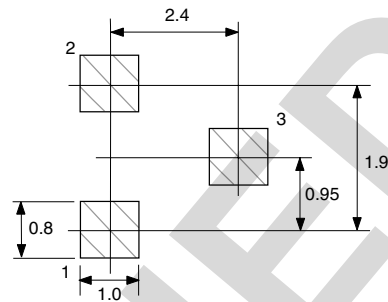

**PACKAGE OUTLINE 35**  
(MICRO-X)

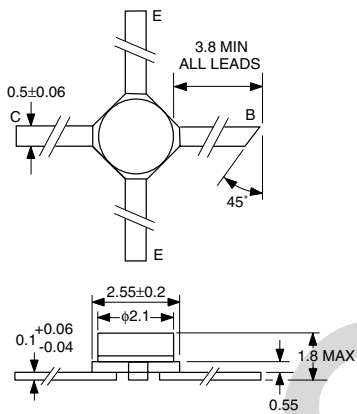

**PIN CONNECTIONS**  
1. Collector  
2. Emitter  
3. Base  
4. Emitter

**PACKAGE OUTLINE 39**  
**RECOMMENDED P.C.B. LAYOUT**

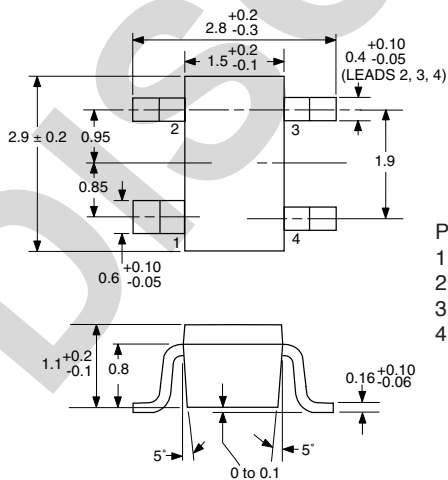

**PIN CONNECTIONS**  
1. Collector  
2. Emitter  
3. Base  
4. Emitter

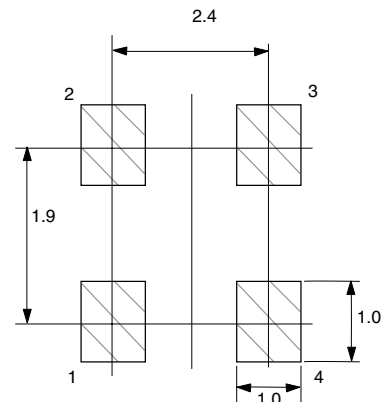

**OUTLINE DIMENSIONS** (Units in mm)

**PACKAGE OUTLINE 39R**

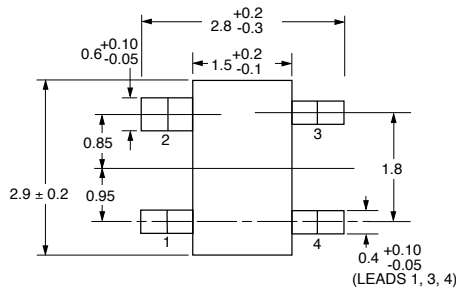

**PIN CONNECTIONS**

- 1. Emitter
- 2. Collector
- 3. Emitter
- 4. Base

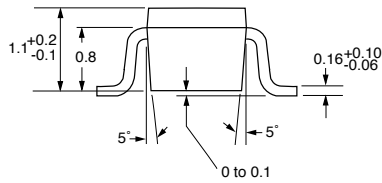

**PACKAGE OUTLINE 39R  
RECOMMENDED P.C.B. LAYOUT**

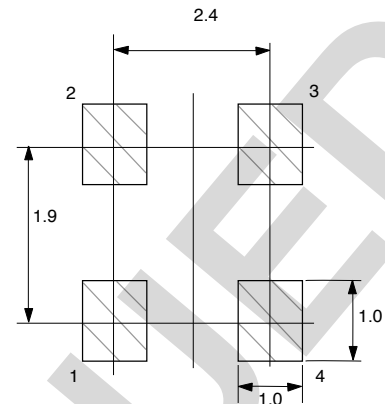

**ORDERING INFORMATION (Solder Contains Lead)**

PART NUMBER	QUANTITY	PACKAGING
NE68100	100	Waffle Pack
NE68118-T1	3000	Tape & Reel
NE68119-T1	3000	Tape & Reel
NE68130-T1	3000	Tape & Reel
NE68133-T1B	3000	Tape & Reel
NE68135	1	ESD Bag
NE68139-T1	3000	Tape & Reel
NE68139R-T1	3000	Tape & Reel

**ORDERING INFORMATION (Pb-Free)**

PART NUMBER	QUANTITY	PACKAGING
NE68100	100	Waffle Pack
NE68118-T1-A	3000	Tape & Reel
NE68119-T1-A	3000	Tape & Reel
NE68130-T1-A	3000	Tape & Reel
NE68133-T1B-A	3000	Tape & Reel
NE68135	1	ESD Bag
NE68139-T1-A	3000	Tape & Reel
NE68139R-T1	3000	Tape & Reel

## Looking for pricing, stock, or lifecycle information?

Click below to explore more details on WIN SOURCE:

 [View 2SC4094-T1-A on WIN SOURCE](#)

 [CEL Information](#)

## Optimize Your Supply Chain with WIN SOURCE Solutions

-  Global Sourcing Solution
-  Obsolete Management
-  Cost Control Management
-  Shortage Management
-  Alternative Solution
-  Excess Inventory Management