



**THE DATASHEET OF  
2SC4140**



# 2SC4140

Silicon NPN Triple Diffused Planar Transistor (High Voltage and High Speed Switching Transistor)

Application : Switching Regulator and General Purpose

### Absolute maximum ratings (Ta=25°C)

Symbol	Ratings	Unit
V <sub>CB0</sub>	500	V
V <sub>CE0</sub>	400	V
V <sub>EB0</sub>	10	V
I <sub>c</sub>	18(Pulse36)	A
I <sub>B</sub>	6	A
P <sub>c</sub>	130(T <sub>c</sub> =25°C)	W
T <sub>j</sub>	150	°C
T <sub>stg</sub>	-55 to +150	°C

### Electrical Characteristics (Ta=25°C)

Symbol	Conditions	Ratings	Unit
I <sub>CB0</sub>	V <sub>CB</sub> =500V	100max	μA
I <sub>EB0</sub>	V <sub>EB</sub> =10V	100max	μA
V <sub>(BR)CEO</sub>	I <sub>c</sub> =25mA	400min	V
h <sub>FE</sub>	V <sub>CE</sub> =4V, I <sub>c</sub> =10A	10 to 30	
V <sub>CE(sat)</sub>	I <sub>c</sub> =10A, I <sub>B</sub> =2A	0.5max	V
V <sub>BE(sat)</sub>	I <sub>c</sub> =10A, I <sub>B</sub> =2A	1.3max	V
f <sub>r</sub>	V <sub>CE</sub> =12V, I <sub>E</sub> =-2.0A	10typ	MHz
COB	V <sub>CB</sub> =10V, f=1MHz	165typ	pF

### External Dimensions MT-100(TO3P)

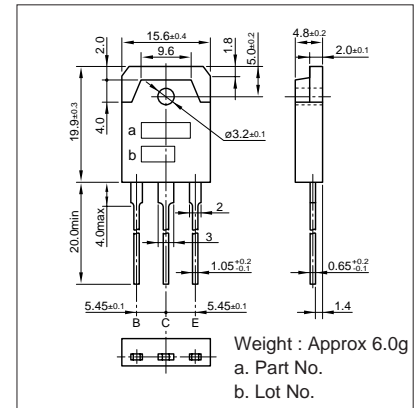

### Typical Switching Characteristics (Common Emitter)

V <sub>CC</sub> (V)	R <sub>L</sub> (Ω)	I <sub>c</sub> (A)	V <sub>BB1</sub> (V)	V <sub>BB2</sub> (V)	I <sub>B1</sub> (A)	I <sub>B2</sub> (A)	t <sub>on</sub> (μs)	t <sub>stg</sub> (μs)	t <sub>f</sub> (μs)
200	20	10	10	-5	1	-2	1max	3max	0.5max

I<sub>c</sub>-V<sub>CE</sub> Characteristics (Typical)

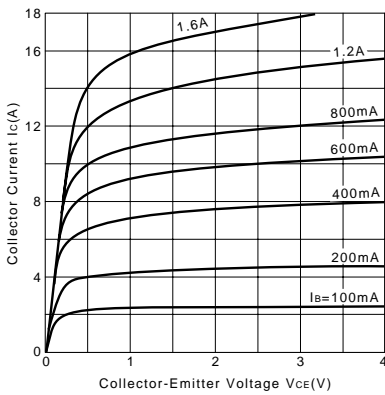

V<sub>CE(sat)</sub>, V<sub>BE(sat)</sub>-I<sub>c</sub> Temperature Characteristics (Typical)

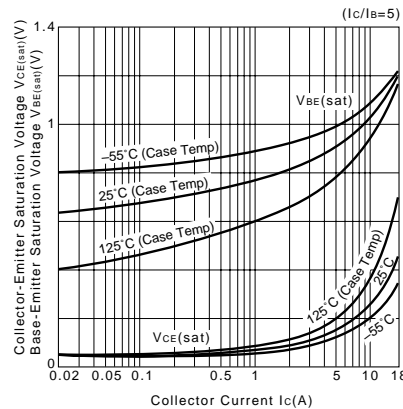

I<sub>c</sub>-V<sub>BE</sub> Temperature Characteristics (Typical)

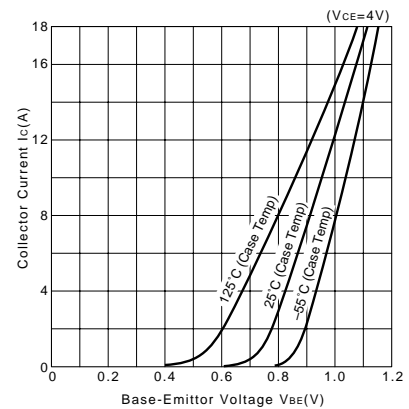

h<sub>FE</sub>-I<sub>c</sub> Characteristics (Typical)

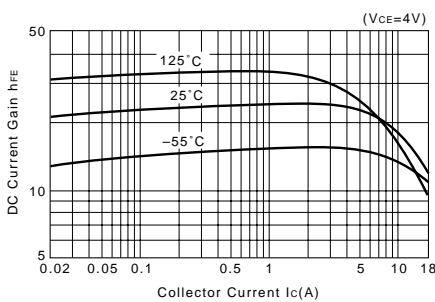

t<sub>on</sub>\*t<sub>stg</sub>\*t<sub>f</sub>-I<sub>c</sub> Characteristics (Typical)

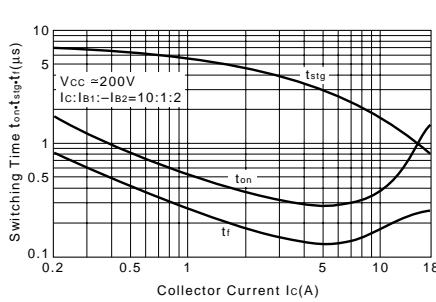

θ<sub>j-a</sub>-t Characteristics

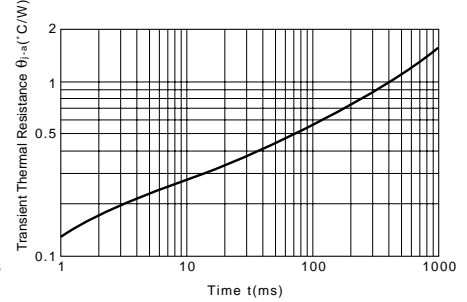

Safe Operating Area (Single Pulse)

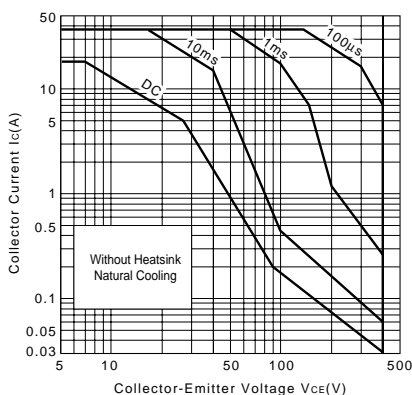

Reverse Bias Safe Operating Area

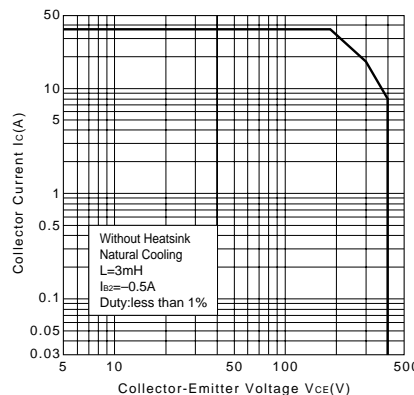

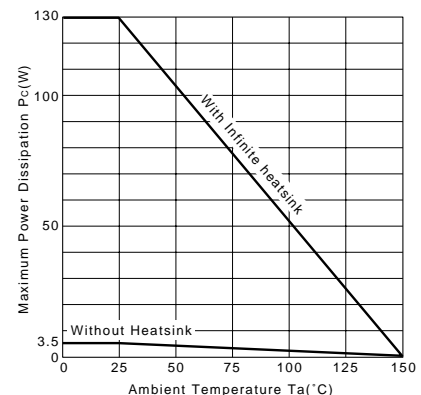

P<sub>c</sub>-T<sub>a</sub> Derating



## Looking for pricing, stock, or lifecycle information?

Click below to explore more details on WIN SOURCE:

-  [View 2SC4140 on WIN SOURCE](#)
-  [Sanken Information](#)

## Optimize Your Supply Chain with WIN SOURCE Solutions

-  Global Sourcing Solution
-  Obsolete Management
-  Cost Control Management
-  Shortage Management
-  Alternative Solution
-  Excess Inventory Management