



# High-Efficiency, 4A, 1MHz, Step-Down Regulators with Integrated Switches in 2mm x 2mm Package

## General Description

The MAX15050/MAX15051 high-efficiency switching regulators deliver up to 4A load current at output voltages from 0.6V to  $(0.9 \times V_{IN})$ . The devices operate from 2.9V to 5.5V, making them ideal for on-board point-of-load and postregulation applications. Total output-voltage accuracy is within  $\pm 1\%$  over load, line, and temperature.

The MAX15050/MAX15051 feature 1MHz fixed-frequency PWM operation. The MAX15050 features pulse-skip mode to improve light-load efficiency. The MAX15050 soft-starts in a monotonic mode and then operates in the forced PWM mode or pulse-skip mode depending on the output load current condition. The MAX15051 soft-starts in the monotonic mode and operates in the forced PWM mode. The high operating frequency allows for small-size external components.

The low-resistance on-chip nMOS switches ensure high efficiency at heavy loads while minimizing critical parasitic inductances, making the layout a much simpler task with respect to discrete solutions. Following a simple layout and footprint ensures first-pass success in new designs.

The MAX15050/MAX15051 incorporate a high-bandwidth ( $> 26\text{MHz}$ ) voltage-error amplifier. The voltage-mode control architecture and the voltage-error amplifier permit a type III compensation scheme to achieve maximum loop bandwidth, up to 200kHz. High loop bandwidth provides fast transient response, resulting in less required output capacitance and allowing for all-ceramic capacitor designs.

The MAX15050/MAX15051 feature an output overload hiccup protection and peak current limit on both high-side and low-side MOSFETs. These features provide for ultra-safe operation in the cases of short-circuit conditions, severe overloads, or in converters with bulk electrolytic capacitors.

The MAX15050/MAX15051 feature an adjustable output voltage. The output voltage is adjustable by using two external resistors at the feedback or by applying an external reference voltage to the REFIN/SS input. The MAX15050/MAX15051 offer programmable soft-start time using one capacitor to reduce input inrush current. A built-in thermal shutdown protection assures safe operation under all conditions. The MAX15050/MAX15051 are available in a 2mm x 2mm, 16-bump (4 x 4 array), 0.5mm pitch WLP package.

## Applications

Server Power Supplies	Telecom and
Point-of-Load	Networking Power
ASIC/CPU/DSP Core	Supplies
and I/O Voltages	RAID Control Power
DDR Power Supplies	Supplies
Base-Station Power	Portable Applications
Supplies	

## Features

- ◆ Internal  $18\text{m}\Omega$   $R_{DS(ON)}$  MOSFETs
- ◆ Pulse-Skip Mode for High-Efficiency Light Load (MAX15050)
- ◆ Continuous 4A Output Current
- ◆  $\pm 1\%$  Output-Voltage Accuracy Over Load, Line, and Temperature
- ◆ Operates from 2.9V to 5.5V Supply
- ◆ Adjustable Output from 0.6V to  $(0.9 \times V_{IN})$
- ◆ Adjustable Soft-Start Reduces Inrush Supply Current
- ◆ Factory-Trimmed 1MHz Switching Frequency
- ◆ Compatible with Ceramic, Polymer, and Electrolytic Output Capacitors
- ◆ Safe Startup Into Prebias Output
- ◆ Enable Input/Power-Good Output
- ◆ Fully Protected Against Overcurrent and Overtemperature
- ◆ Overload Hiccup Protection
- ◆ Sink/Source Current for DDR Applications
- ◆ 2mm x 2mm, 16-Bump (4 x 4 Array), 0.5mm Pitch WLP Package

## Ordering Information

PART	TEMP RANGE	PIN-PACKAGE	SKIP MODE
MAX15050EWE+	-40°C to +85°C	16 WLP	Yes
MAX15051EWE+	-40°C to +85°C	16 WLP	No

+Denotes a lead(Pb)-free/RoHS-compliant package.

## Typical Operating Circuit

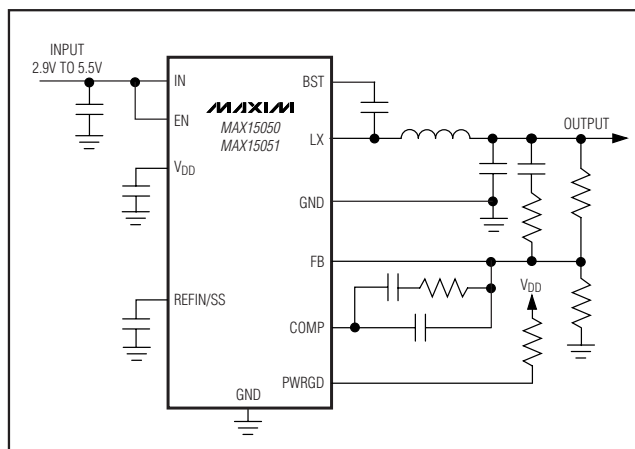

Pin Configuration appears at end of data sheet.

# High-Efficiency, 4A, 1MHz, Step-Down Regulators with Integrated Switches in 2mm x 2mm Package

## ABSOLUTE MAXIMUM RATINGS

IN, PWRGD to GND	-0.3V to +6V
V <sub>DD</sub> to GND	-0.3V to the lower of +4V or (V <sub>IN</sub> + 0.3V)
COMP, FB, REFIN/SS to GND	-0.3V to (V <sub>DD</sub> + 0.3V)
EN to GND	-0.3V to +6V
BST to LX	-0.3V to +6V
BST to GND	-0.3V to +12V
LX to GND	-0.3V to the lower of +6V or (V <sub>IN</sub> + 0.3V)
LX to GND (Note 1)	-1V to the lower of +6V or (V <sub>IN</sub> + 1V) for 50ns
I <sub>LX(RMS)</sub>	6A
V <sub>DD</sub> Output Short-Circuit Duration	Continuous
Converter Output Short-Circuit Duration	Continuous

Continuous Power Dissipation (T <sub>A</sub> = +70°C)	16-Bump (4 x 4 Array), 0.5mm Pitch WLP (derate 20.4mW/°C above +70°C)	1000mW
Thermal Resistance (Note 2)		
θ <sub>JA</sub>		49°C/W
θ <sub>JC</sub>		9°C/W
Operating Temperature Range		-40°C to +85°C
Junction Temperature		+150°C
Operating Junction Temperature at Maximum Current (Note 3)		+105°C
Storage Temperature Range		-65°C to +150°C
Soldering Temperature (soldering, 10s)		+260°C

**Note 1:** LX has internal clamp diodes to GND and IN. Applications that forward bias these diodes should take care not to exceed the IC's power dissipation limit of the device.

**Note 2:** Package thermal resistances were obtained using the method described in JEDEC specification JESD51-7, using a four-layer board. For detailed information on package thermal considerations, refer to [www.maxim-ic.com/thermal-tutorial](http://www.maxim-ic.com/thermal-tutorial).

**Note 3:** Operating the junction temperature above +105°C will degrade the life of the device.

Stresses beyond those listed under "Absolute Maximum Ratings" may cause permanent damage to the device. These are stress ratings only, and functional operation of the device at these or any other conditions beyond those indicated in the operational sections of the specifications is not implied. Exposure to absolute maximum rating conditions for extended periods may affect device reliability.

## ELECTRICAL CHARACTERISTICS

(V<sub>IN</sub> = V<sub>EN</sub> = 5V, C<sub>VDD</sub> = 2.2μF, T<sub>A</sub> = -40°C to +85°C, typical values are at T<sub>A</sub> = +25°C, unless otherwise noted.) (Note 4)

PARAMETER	CONDITIONS	MIN	TYP	MAX	UNITS
IN Voltage Range		2.9		5.5	V
IN Supply Current	No load, no switching	V <sub>IN</sub> = 3.3V	4.8	8	mA
		V <sub>IN</sub> = 5V	5.3	8.5	
Total Shutdown Current from IN	V <sub>IN</sub> = V <sub>BST</sub> - V <sub>LX</sub> = 5V, V <sub>EN</sub> = 0V		10	20	μA
V <sub>DD</sub> Undervoltage Lockout Threshold	LX starts/stops switching, no load	V <sub>DD</sub> rising	2.6	2.8	V
		V <sub>DD</sub> falling	2.35	2.55	
V <sub>DD</sub> Undervoltage Deglitching			10		μs
V <sub>DD</sub> Output Voltage	I <sub>VDD</sub> = 0 to 10mA	3.1	3.3	3.5	V
V <sub>DD</sub> Dropout	V <sub>IN</sub> = 2.9V, I <sub>VDD</sub> = 10mA			0.09	V
V <sub>DD</sub> Current Limit	V <sub>DD</sub> = 0V	20	37		mA
<b>BST</b>					
BST Supply Current	MAX15050, V <sub>BST</sub> = 5V, V <sub>LX</sub> = 0V, no switching		10		μA
	MAX15051, V <sub>IN</sub> = V <sub>LX</sub> = 3.3V, V <sub>BST</sub> = 6.6V, no switching		250		
IN to BST On-Resistance	V <sub>IN</sub> = 3.3V, I <sub>IN</sub> = 0.16A		4		Ω
<b>PWM COMPARATOR</b>					
PWM Comparator Propagation Delay	10mV overdrive		20		ns
PWM Peak-to-Peak Ramp Amplitude			1		V
PWM Valley Amplitude			0.76		V

# High-Efficiency, 4A, 1MHz, Step-Down Regulators with Integrated Switches in 2mm x 2mm Package

MAX15050/MAX15051

## ELECTRICAL CHARACTERISTICS (continued)

( $V_{IN} = V_{EN} = 5V$ ,  $C_{VDD} = 2.2\mu F$ ,  $T_A = -40^\circ C$  to  $+85^\circ C$ , typical values are at  $T_A = +25^\circ C$ , unless otherwise noted.) (Note 4)

PARAMETER	CONDITIONS		MIN	TYP	MAX	UNITS
<b>COMP</b>						
COMP Clamp Voltage High	$V_{DD} = 2.9V$ to $5V$ , $V_{FB} = 0.5V$ , $V_{REFIN/SS} = 0.6V$		2			V
COMP Clamp Voltage Low	$V_{DD} = 2.9V$ to $5V$ , $V_{FB} = 0.7V$ , $V_{REFIN/SS} = 0.6V$		0.68			V
COMP Slew Rate	$V_{FB} = 0.7V$ to $0.5V$ , $V_{REFIN/SS} = 0.6V$		1.4			V/ $\mu s$
COMP Shutdown Resistance	From COMP to GND, $V_{IN} = 3.3V$ , $V_{COMP} = 100mV$ , $V_{EN} = V_{REFIN/SS} = 0V$		6			$\Omega$
<b>ERROR AMPLIFIER</b>						
FB Regulation Accuracy Using External Resistors			0.594	0.6	0.606	V
Open-Loop Voltage Gain			115			dB
Error-Amplifier Unity-Gain Bandwidth			26			MHz
Error-Amplifier Common-Mode Input Range	$V_{DD} = 2.9V$ to $3.5V$		0		$V_{DD} - 2$	V
Error-Amplifier Maximum Output Current	$V_{COMP} = 1V$ , no switching, $V_{REFIN/SS} = 0.6V$	$V_{FB} = 0.7V$ , sink	1			mA
		$V_{FB} = 0.5V$ , source	-1			
FB Input Bias Current	$V_{FB} = 0.7V$		70			nA
<b>REFIN/SS</b>						
REFIN/SS Common-Mode Range	$V_{DD} = 2.9V$ to $3.5V$		0		$V_{DD} - 2$	V
REFIN/SS Charging Current	$V_{REFIN/SS} = 0.45V$		6	8	10	$\mu A$
REFIN/SS Offset Voltage	$V_{REFIN/SS} = 0.9V$ , FB shorted to COMP		-4.5		+4.5	mV
REFIN/SS Pulldown Resistance	$V_{IN} = V_{DD} = 3.3V$ , $V_{REFIN/SS} = 0.1V$		300			$\Omega$
<b>LX (ALL BUMPS COMBINED)</b>						
LX On-Resistance, High Side	$I_{LX} = -500mA$	$V_{IN} = V_{BST} - V_{LX} = 3.3V$		24	54	$m\Omega$
LX On-Resistance, Low Side	$I_{LX} = 500mA$	$V_{IN} = 3.3V$		18	50	$m\Omega$
LX Current-Limit Thresholds	$V_{IN} = 3.3V$	High-side sourcing	5.4	8		A
		Low-side sourcing	7			
		Low-side sinking	7			
		Zero-crossing current threshold	0.2			
		Skip high-side sourcing	0.58			
		Sink current-limit DAC steps	4			Steps
LX Leakage Current	$V_{EN} = 0V$	$V_{LX} = 0V$	-10			$\mu A$
		$V_{LX} = 5V$	10			
LX Switching Frequency	$V_{IN} = 3.3V$		0.9	1	1.1	MHz
LX Maximum Duty Cycle	$V_{IN} = 3.3V$		90	96		%
LX Minimum On-Time	$V_{IN} = 3.3V$		80			ns
RMS LX Output Current			4			A
<b>ENABLE</b>						
EN Input Logic-Low Threshold (Falling)					0.7	V

# High-Efficiency, 4A, 1MHz, Step-Down Regulators with Integrated Switches in 2mm x 2mm Package

## ELECTRICAL CHARACTERISTICS (continued)

( $V_{IN} = V_{EN} = 5V$ ,  $C_{VDD} = 2.2\mu F$ ,  $T_A = -40^\circ C$  to  $+85^\circ C$ , typical values are at  $T_A = +25^\circ C$ , unless otherwise noted.) (Note 4)

PARAMETER	CONDITIONS	MIN	TYP	MAX	UNITS
EN Input Logic-High Threshold (Rising)		1.5			V
EN Input Current	$V_{EN} = 0$ or $5V$		0.01	1	$\mu A$
<b>THERMAL SHUTDOWN</b>					
Thermal-Shutdown Threshold			+165		$^\circ C$
Thermal-Shutdown Hysteresis			20		$^\circ C$
<b>POWER-GOOD (PWRGD)</b>					
Power-Good Threshold Voltage	$V_{FB}$ falling, $V_{REFIN/SS} = 0.6V$	87	90	93	% of $V_{REFIN/SS}$
	$V_{FB}$ rising, $V_{REFIN/SS} = 0.6V$		92.5		
Power-Good Edge Deglitch	$V_{FB}$ falling or rising		48		Clock cycles
PWRGD Output-Voltage Low	$I_{PWRGD} = 4mA$		0.03	0.15	V
PWRGD Leakage Current	$V_{PWRGD} = 5V$ , $V_{FB} = 0.9V$ , $V_{REFIN/SS} = 0.6V$		0.1	1	$\mu A$
<b>OVERCURRENT LIMIT (HICCUP MODE)</b>					
Current-Limit Startup Blanking			112		Clock cycles
Autoretry Restart Time			896		Clock cycles
FB Hiccup Threshold	$V_{FB}$ falling		70		% of $V_{REFIN/SS}$
Hiccup Threshold Blanking Time	$V_{FB}$ falling		36		$\mu s$

**Note 4:** Specifications are 100% production tested at  $T_A = +25^\circ C$ . Limits over the operating temperature range are guaranteed by design and characterization.

## Typical Operating Characteristics

( $V_{IN} = 5V$ , output voltage = 1.8V,  $I_{LOAD} = 4A$ , and  $T_A = +25^\circ C$ , circuit of Figure 1, unless otherwise noted.)

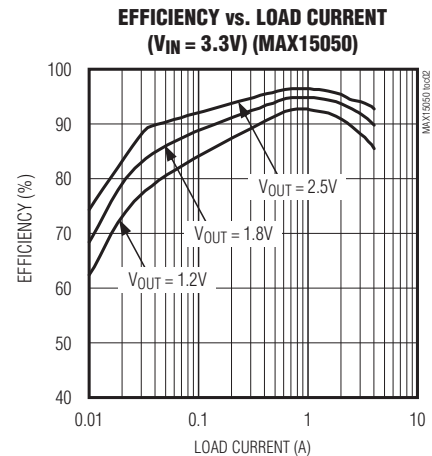
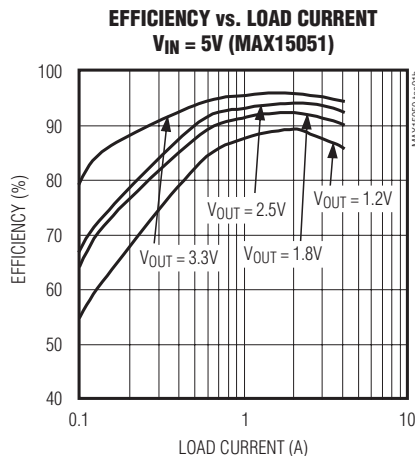
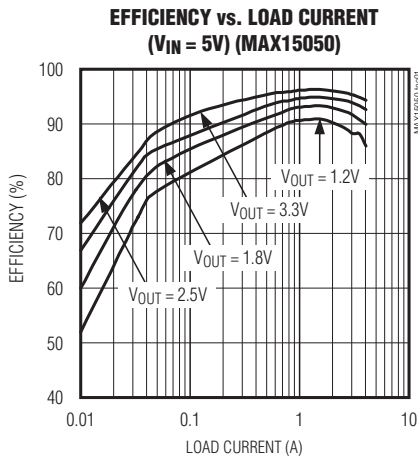

# High-Efficiency, 4A, 1MHz, Step-Down Regulators with Integrated Switches in 2mm x 2mm Package

## Typical Operating Characteristics (continued)

( $V_{IN} = 5V$ , output voltage = 1.8V,  $I_{LOAD} = 4A$ , and  $T_A = +25^\circ C$ , circuit of Figure 1, unless otherwise noted.)

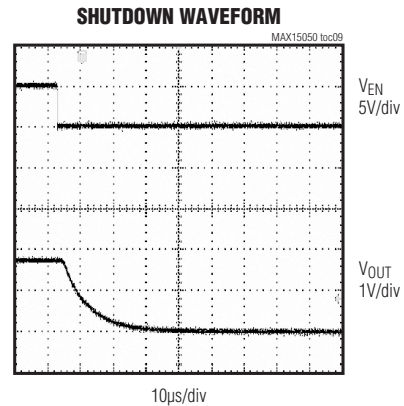
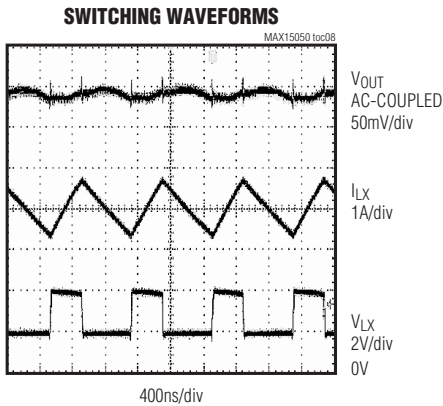
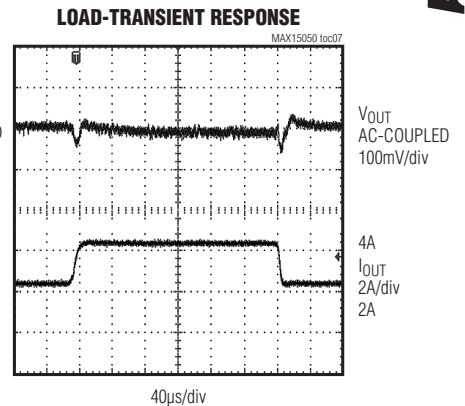
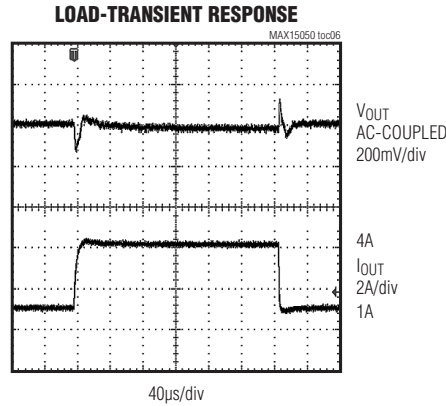
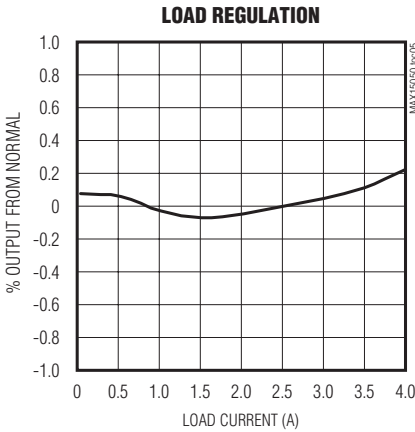
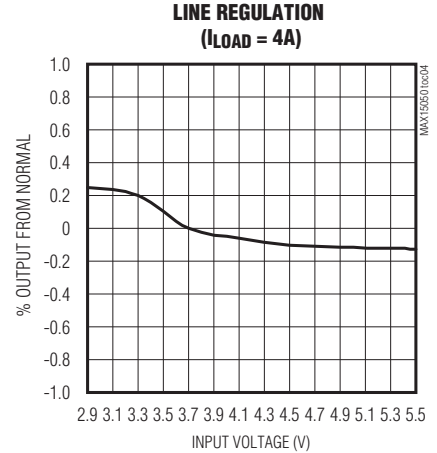
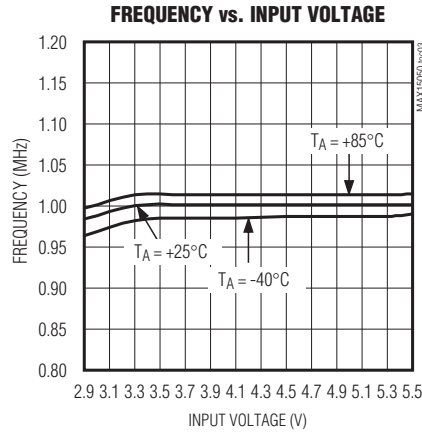
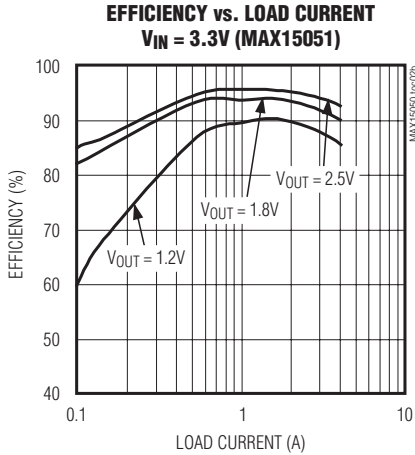

MAX15050/MAX15051

# High-Efficiency, 4A, 1MHz, Step-Down Regulators with Integrated Switches in 2mm x 2mm Package

## Typical Operating Characteristics (continued)

( $V_{IN} = 5V$ , output voltage = 1.8V,  $I_{LOAD} = 4A$ , and  $T_A = +25^\circ C$ , circuit of Figure 1, unless otherwise noted.)

**SOFT-START WAVEFORM**

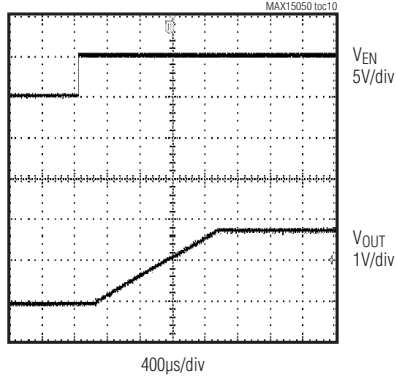

**INPUT SHUTDOWN CURRENT vs. INPUT VOLTAGE**

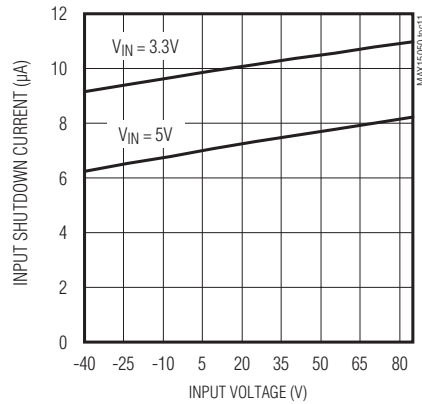

**HICCUP CURRENT LIMIT**

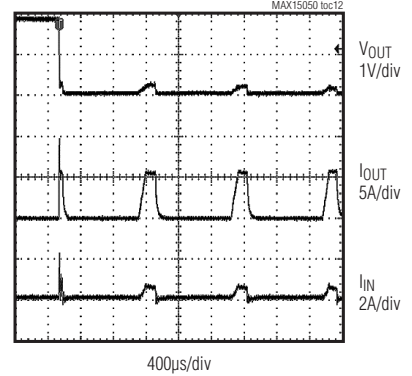

**RMS INPUT CURRENT DURING SHORT CIRCUIT vs. INPUT VOLTAGE**

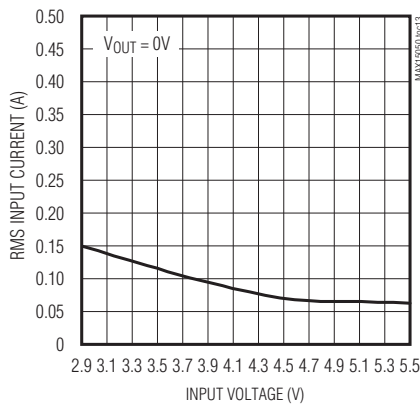

**FEEDBACK VOLTAGE vs. TEMPERATURE**

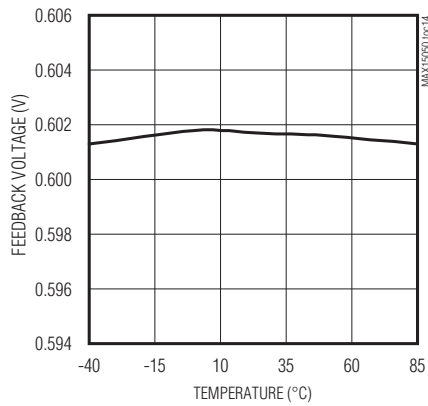

**SOFT-START WITH REFIN/SS**

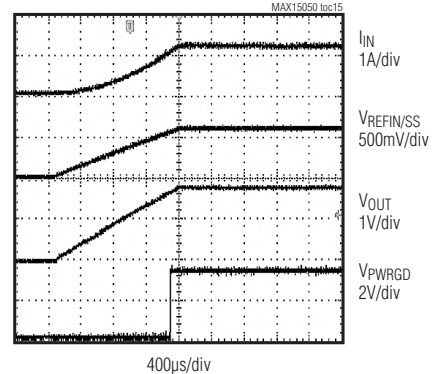

**STARTING INTO PREBIASED OUTPUT WITH 2A LOAD**

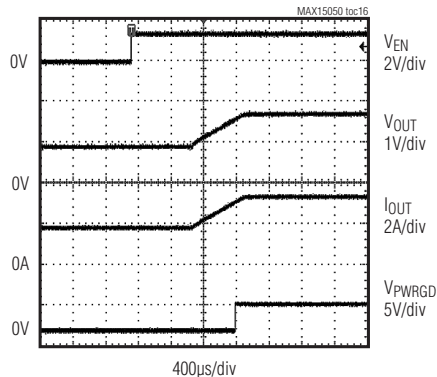

**STARTING INTO PREBIASED OUTPUT WITH NO LOAD**

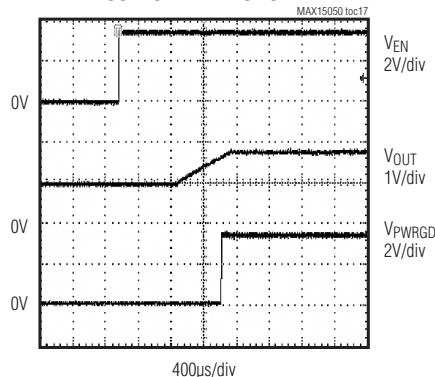

# High-Efficiency, 4A, 1MHz, Step-Down Regulators with Integrated Switches in 2mm x 2mm Package

## Typical Operating Characteristics (continued)

( $V_{IN} = 5V$ , output voltage = 1.8V,  $I_{LOAD} = 4A$ , and  $T_A = +25^\circ C$ , circuit of Figure 1, unless otherwise noted.)

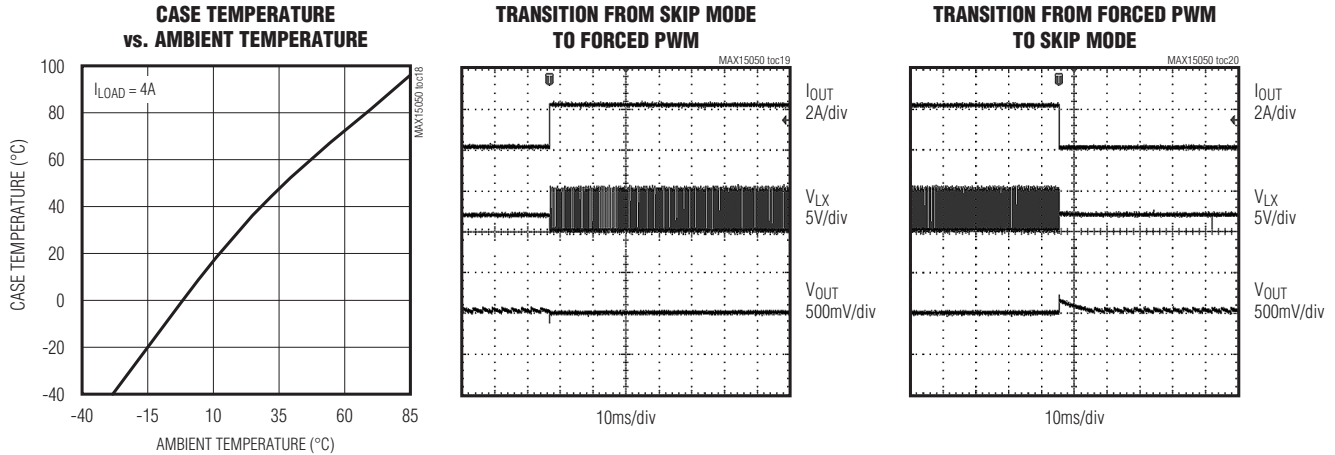

## Pin Description

BUMP	NAME	FUNCTION
A1, A2	GND	Analog/Power Ground. Connect GND to the PCB ground plane at one point near the input bypass capacitor return terminal as close as possible to the device.
A3, A4	IN	Power-Supply Input. Input supply range is from 2.9V to 5.5V. Bypass IN to GND with a 22 $\mu$ F ceramic capacitor in parallel to a 0.1 $\mu$ F ceramic capacitor as close as possible to the device.
B1, B2, B3	LX	Inductor Connection. All LX bumps are internally connected together. Connect all LX bumps to the switched side of the inductor. LX is high impedance when the device is in shutdown mode.
B4	V <sub>DD</sub>	3.3V LDO Output. V <sub>DD</sub> powers the internal analog core. Connect a low-ESR, ceramic capacitor with a minimum value of 2.2 $\mu$ F from V <sub>DD</sub> to GND.
C1	BST	High-Side MOSFET Driver Supply. Connect BST to LX with a 0.1 $\mu$ F capacitor.
C2, C3	I.C.	Internally Connected. Leave unconnected or connect to ground.
C4	EN	Enable Input. Connect EN to GND to disable the device. Connect EN to IN to enable the device.
D1	PWRGD	Power-Good Output. PWRGD is an open-drain output that goes high impedance when $V_{FB}$ exceeds 92.5% of $V_{REFIN/SS}$ and $V_{REFIN/SS}$ is above 0.54V. PWRGD is internally pulled low when $V_{FB}$ falls below 90% of $V_{REFIN/SS}$ or $V_{REFIN/SS}$ is below 0.54V. PWRGD is internally pulled low when the device is in shutdown mode, V <sub>DD</sub> is below the internal UVLO threshold, or the device is in thermal shutdown.
D2	FB	Feedback Input. Connect FB to the center tap of an external resistor-divider from the output to GND to set the output voltage from 0.6V to 90% of $V_{IN}$ .
D3	COMP	Voltage-Error Amplifier Output. Connect the necessary compensation network from COMP to FB and the converter output (see the <i>Compensation Design</i> section). COMP is internally pulled to GND when the device is in shutdown mode.
D4	REFIN/SS	External Reference Input/Soft-Start Timing Capacitor Connection. Connect REFIN/SS to a system voltage to force FB to regulate to REFIN/SS voltage. REFIN/SS is internally pulled to GND when the device is in shutdown and thermal shutdown mode. If no external reference is applied, the internal 0.6V reference is automatically selected. REFIN/SS is also used to perform soft-start. Connect a minimum of 1nF capacitor from REFIN/SS to GND to set the startup time (see the <i>Soft-Start and Reference Input (REFIN/SS)</i> section).

# High-Efficiency, 4A, 1MHz, Step-Down Regulators with Integrated Switches in 2mm x 2mm Package

## Block Diagram

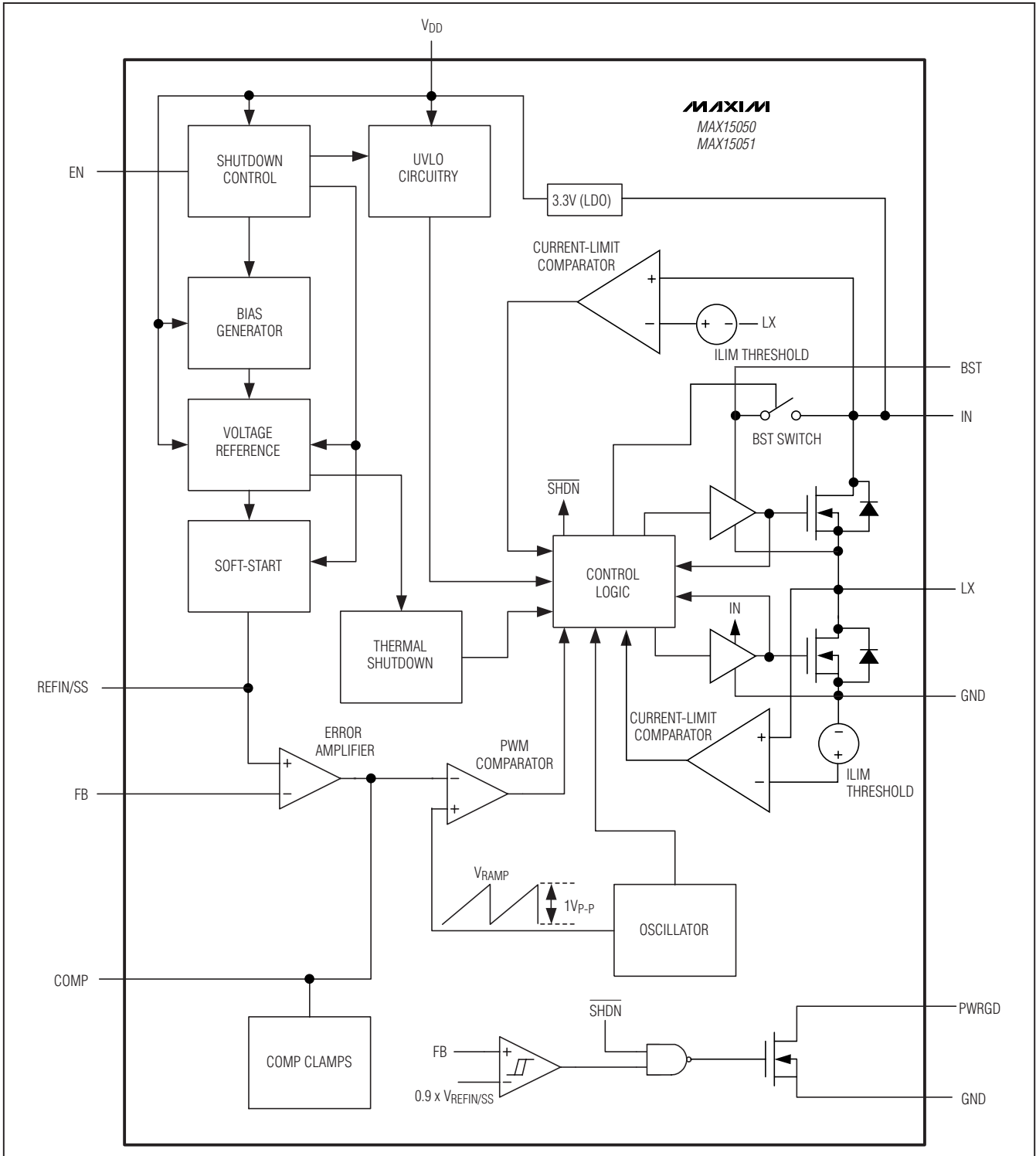

# High-Efficiency, 4A, 1MHz, Step-Down Regulators with Integrated Switches in 2mm x 2mm Package

## Typical Application Circuit

MAX15050/MAX15051

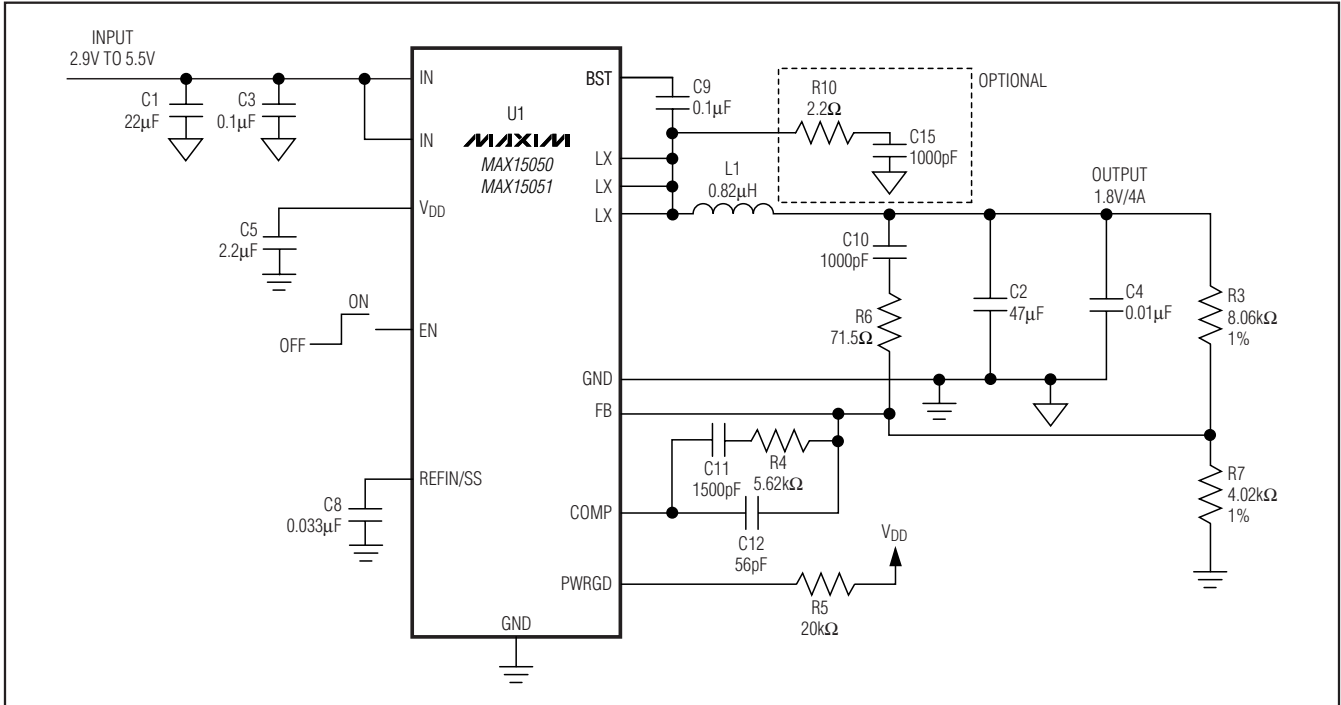

Figure 1. All-Ceramic Capacitor Design with  $V_{OUT} = 1.8V$

### Detailed Description

The MAX15050/MAX15051 high-efficiency, voltage-mode switching regulators can deliver up to 4A of output current. The MAX15050/MAX15051 provide output voltages from 0.6V to  $(0.9 \times V_{IN})$  from 2.9V to 5.5V input supplies, making them ideal for on-board point-of-load applications. The output-voltage accuracy is better than  $\pm 1\%$  over load, line, and temperature.

The MAX15050/MAX15051 feature a 1MHz fixed switching frequency, allowing the user to achieve all-ceramic capacitor designs and fast transient responses. The high operating frequency minimizes the size of external components. The MAX15050/MAX15051 are available in a 2mm x 2mm, 16-bump (4 x 4 array), 0.5mm pitch WLP package. The REFIN/SS function makes the MAX15050/MAX15051 ideal solutions for DDR and tracking power supplies. Using internal low- $R_{DS(ON)}$  (24m $\Omega$  and 18m $\Omega$ ) n-channel MOSFETs for the high- and low-side switches, respectively, maintains high efficiency at both heavy-load and high-switching frequencies.

The MAX15050/MAX15051 employ voltage-mode control architecture with a high-bandwidth ( $> 26\text{MHz}$ ) error amplifier. The op-amp voltage-error amplifier works with

type III compensation to fully utilize the bandwidth of the high-frequency switching to obtain fast transient response. Adjustable soft-start time provides flexibilities to minimize input startup inrush current. An open-drain, power-good (PWRGD) output goes high impedance when  $V_{FB}$  exceeds 92.5% of  $V_{REFIN/SS}$  and  $V_{REFIN/SS}$  is above 0.54V. PWRGD goes low when  $V_{FB}$  falls below 90% of  $V_{REFIN/SS}$  or  $V_{REFIN/SS}$  is below 0.54V.

### Controller Function

The controller logic block is the central processor that determines the duty cycle of the high-side MOSFET under different line, load, and temperature conditions. Under normal operation, where the current-limit and temperature protection are not triggered, the controller logic block takes the output from the PWM comparator and generates the driver signals for both high-side and low-side MOSFETs. The control logic block controls the break-before-make logic and the timing for charging the bootstrap capacitors. The error signal from the voltage-error amplifier is compared with the ramp signal generated by the oscillator at the PWM comparator to produce the required PWM signal. The high-side switch turns on at the beginning of the oscillator cycle and

# High-Efficiency, 4A, 1MHz, Step-Down Regulators with Integrated Switches in 2mm x 2mm Package

turns off when the ramp voltage exceeds the V<sub>COMP</sub> signal or the current-limit threshold is exceeded. The low-side switch then turns on for the remainder of the oscillator cycle.

## Skip Mode (MAX15050)

The MAX15050 features a skip function. In skip mode, the MAX15050 switches only as necessary to maintain the output at light loads (not capable of sinking current from the output). This maximizes light-load efficiency and reduces the input quiescent current.

In skip mode, the low-side switch is turned off when the inductor current decreases to 0.2A (typ) to ensure no reverse current flowing from the output capacitor.

The high-side switch minimum on-time is controlled to guarantee that 0.9A current is reached to avoid high frequency bursts at no-load conditions, which prevents a rapid increase of the supply current caused by additional switching losses. Under heavy load, the device operates as a PWM converter.

## Current Limit

The internal, high-side MOSFET has a typical 8A peak current-limit threshold. When current flowing out of LX exceeds this limit, the high-side MOSFET turns off and the low-side MOSFET turns on. The low-side MOSFET remains on until the inductor current falls below the low-side current limit. This lowers the duty cycle and causes the output voltage to droop until the current limit is no longer exceeded. The MAX15050/MAX15051 use a hiccup mode to prevent overheating during short-circuit output conditions.

During current limit, if V<sub>FB</sub> drops below 70% of V<sub>REFIN/SS</sub> and stays below this level for typically 36μs or more, the device enters hiccup mode. The high-side MOSFET and the low-side MOSFET turn off and both COMP and REF<sub>IN/SS</sub> are internally pulled low. The device remains in this state for 896 clock cycles and then attempts to restart for 112 clock cycles. If the fault-causing current limit has cleared, the device resumes normal operation. Otherwise, the device reenters hiccup mode.

## Soft-Start and Reference Input (REFIN/SS)

The MAX15050/MAX15051 utilize an adjustable soft-start function to limit inrush current during startup. An 8μA (typ) current source charges an external capacitor connected to REF<sub>IN/SS</sub>. The soft-start time is adjusted by the value of the external capacitor from REF<sub>IN/SS</sub> to GND. The required capacitance value is determined as:

$$C = \frac{8\mu\text{A} \times t_{\text{SS}}}{0.6\text{V}}$$

where t<sub>SS</sub> is the required soft-start time in seconds. Connect a minimum 1nF capacitor between REF<sub>IN/SS</sub> and GND. REF<sub>IN/SS</sub> is also an external reference input (REF<sub>IN/SS</sub>). The device regulates FB to the voltage applied to REF<sub>IN/SS</sub>. The internal soft-start is not available when using an external reference. Figure 2 shows a method of soft-start when using an external reference. If an external reference is not applied, the device uses the internal 0.6V reference.

## Undervoltage Lockout (UVLO)

The UVLO circuitry inhibits switching when V<sub>DD</sub> is below 2.55V (typ). Once V<sub>DD</sub> rises above 2.6V (typ), UVLO clears and the soft-start function activates. A 50mV hysteresis is built-in for glitch immunity.

## BST

The gate-drive voltage for the high-side, n-channel switch is generated by a flying-capacitor boost circuit. The capacitor between BST and LX is charged from the V<sub>IN</sub> supply while the low-side MOSFET is on. When the low-side MOSFET is switched off, the voltage of the capacitor is stacked above LX to provide the necessary turn-on voltage for the high-side internal MOSFET.

## Power-Good Output (PWRGD)

PWRGD is an open-drain output that goes high impedance when V<sub>FB</sub> is above 92.5% x V<sub>REFIN/SS</sub> and V<sub>REFIN/SS</sub> is above 0.54V. PWRGD pulls low when V<sub>FB</sub> is below 90% of V<sub>REFIN/SS</sub> for at least 48 clock cycles or V<sub>REFIN/SS</sub> is below 0.54V. PWRGD is low during shutdown.

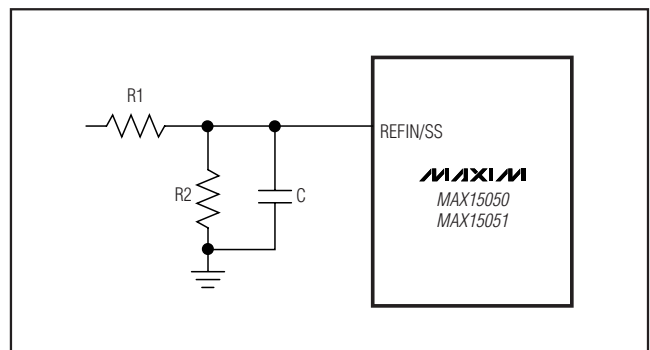

Figure 2. Typical Soft-Start Implementation with External Reference

# High-Efficiency, 4A, 1MHz, Step-Down Regulators with Integrated Switches in 2mm x 2mm Package

MAX15050/MAX15051

## Setting the Output Voltage

The MAX15050/MAX15051 output voltage is adjustable from 0.6V to 90% of  $V_{IN}$  by connecting FB to the center tap of a resistor-divider between the output and GND (Figure 3). To determine the values of the resistor-divider, first select the value of R3 between 2k $\Omega$  and 10k $\Omega$ . Then use the following equation to calculate R4:

$$R4 = (V_{FB} \times R3) / (V_{OUT} - V_{FB})$$

where  $V_{FB}$  is equal to the reference voltage at REF<sub>IN</sub>/SS and  $V_{OUT}$  is the output voltage. For  $V_{OUT} = V_{FB}$ , remove R4. If no external reference is applied at REF<sub>IN</sub>/SS, the internal reference is automatically selected and  $V_{FB}$  becomes 0.6V.

## Shutdown Mode

Drive EN to GND to shut down the device and reduce quiescent current to less than 10 $\mu$ A. During shutdown, LX is high impedance. Drive EN high to enable the MAX15050/MAX15051.

## Thermal Protection

Thermal-overload protection limits total power dissipation in the device. When the junction temperature exceeds  $T_J = +165^\circ\text{C}$ , a thermal sensor forces the device into shutdown, allowing the die to cool. The thermal sensor turns the device on again after the junction temperature cools by 20 $^\circ\text{C}$ , causing a pulsed output during continuous overload conditions. The soft-start sequence begins after recovery from a thermal-shutdown condition.

## Applications Information

### IN and VDD Decoupling

To decrease the noise effects due to the high switching frequency and maximize the output accuracy of the MAX15050/MAX15051, decouple  $V_{IN}$  with a 22 $\mu$ F capacitor in parallel with a 0.1 $\mu$ F capacitor from  $V_{IN}$  to GND. Also decouple  $V_{DD}$  with a 2.2 $\mu$ F capacitor from  $V_{DD}$  to GND. Place these capacitors as close as possible to the device.

### Inductor Selection

Choose an inductor with the following equation:

$$L = \frac{V_{OUT} \times (V_{IN} - V_{OUT})}{f_S \times V_{IN} \times LIR \times I_{OUT(MAX)}}$$

where LIR is the ratio of the inductor ripple current to full load current at the minimum duty cycle and  $f_S$  is the switching frequency (1MHz). Choose LIR between 20% to 40% for best performance and stability.

Use an inductor with the lowest possible DC resistance that fits in the allotted dimensions. Powdered iron or fer-

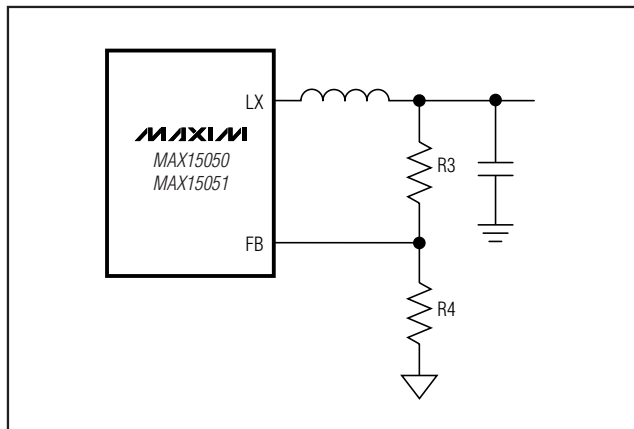

Figure 3. Setting the Output Voltage with a Resistor Voltage-Divider

rite core types are often the best choice for performance. With any core material, the core must be large enough not to saturate at the current limit of the MAX15050/MAX15051.

### Output-Capacitor Selection

The key selection parameters for the output capacitor are capacitance, ESR, ESL, and voltage-rating requirements. These affect the overall stability, output ripple voltage, and transient response of the DC-DC converter. The output ripple occurs due to variations in the charge stored in the output capacitor, the voltage drop due to the capacitor's ESR, and the voltage drop due to the capacitor's ESL. Estimate the output-voltage ripple due to the output capacitance, ESR, and ESL as follows:

$$V_{RIPPLE} = V_{RIPPLE(C)} + V_{RIPPLE(ESR)} + V_{RIPPLE(ESL)}$$

where the output ripple due to output capacitance, ESR, and ESL is:

$$V_{RIPPLE(C)} = \frac{I_{P-P}}{8 \times C_{OUT} \times f_S}$$

$$V_{RIPPLE(ESR)} = I_{P-P} \times ESR$$

and 
$$V_{RIPPLE(ESL)} = \frac{I_{P-P}}{t_{ON}} \times ESL \text{ or}$$

$$V_{RIPPLE(ESL)} = \frac{I_{P-P}}{t_{OFF}} \times ESL$$

whichever is higher.

# High-Efficiency, 4A, 1MHz, Step-Down Regulators with Integrated Switches in 2mm x 2mm Package

The peak-to-peak inductor current ( $I_{P-P}$ ) is:

$$I_{P-P} = \frac{V_{IN} - V_{OUT}}{f_S \times L} \times \frac{V_{OUT}}{V_{IN}}$$

Use these equations for initial output-capacitor selection. Determine final values by testing a prototype or an evaluation circuit. A smaller ripple current results in less output-voltage ripple. Since the inductor ripple current is a factor of the inductor value, the output-voltage ripple decreases with larger inductance. Use ceramic capacitors for low ESR and low ESL at the switching frequency of the converter. The ripple voltage due to ESL is negligible when using ceramic capacitors.

Load-transient response depends on the selected output capacitance. During a load transient, the output instantly changes by  $ESR \times \Delta I_{LOAD}$ . Before the controller can respond, the output deviates further, depending on the inductor and output capacitor values. After a short time, the controller responds by regulating the output voltage back to its predetermined value. The controller response time depends on the closed-loop bandwidth. A higher bandwidth yields a faster response time, preventing the output from deviating further from its regulating value. See the *Compensation Design* section for more details. The minimum recommended output capacitance for the MAX15051 and MAX15050 is  $47\mu F$  and  $22\mu F$ , respectively.

## Input-Capacitor Selection

When transitioning from skip mode to PWM mode (MAX15050) with a large current load step, additional output capacitance can be used to help minimize the load-transient response. The input capacitor reduces the current peaks drawn from the input power supply and reduces switching noise in the device. The total input capacitance must be equal to or greater than the value given by the following equation to keep the input ripple voltage within the specification and minimize the high-frequency ripple current being fed back to the input source:

$$C_{IN\_MIN} = \frac{D \times T_S \times I_{OUT}}{V_{IN\_RIPPLE}}$$

where  $V_{IN\_RIPPLE}$  is the maximum-allowed input ripple voltage across the input capacitors and is recommended to be less than 2% of the minimum input voltage,  $D$  is the duty cycle ( $V_{OUT}/V_{IN}$ ),  $T_S$  is the switching period ( $1/f_S$ ) =  $1\mu s$ , and  $I_{OUT}$  is the output load.

The impedance of the input capacitor at the switching frequency should be less than that of the input source so high-frequency switching currents do not pass through the input source, but are instead shunted through the input capacitor. The input capacitor must meet the ripple

current requirement imposed by the switching currents. The RMS input ripple current is given by:

$$I_{RIPPLE} = I_{LOAD} \times \frac{\sqrt{V_{OUT} \times (V_{IN} - V_{OUT})}}{V_{IN}}$$

where  $I_{RIPPLE}$  is the input RMS ripple current.

## Compensation Design

The power transfer function consists of one double pole and one zero. The double pole is introduced by the inductor,  $L$ , and the output capacitor,  $C_O$ . The ESR of the output capacitor determines the zero. The double pole and zero frequencies are given as follows:

$$f_{P1\_LC} = f_{P2\_LC} = \frac{1}{2\pi \times \sqrt{L \times C_O \times \left(\frac{R_O + ESR}{R_O + R_L}\right)}}$$

$$f_{Z\_ESR} = \frac{1}{2\pi \times ESR \times C_O}$$

where  $R_L$  is equal to the sum of the output inductor's DC resistance (DCR) and the internal switch resistance,  $R_{DS(ON)}$ . A typical value for  $R_{DS(ON)}$  is  $25m\Omega$ .  $R_O$  is the output load resistance, which is equal to the rated output voltage divided by the rated output current. ESR is the total equivalent series resistance of the output capacitor. If there is more than one output capacitor of the same type in parallel, the value of the ESR in the above equation is equal to that of the ESR of a single output capacitor divided by the total number of output capacitors.

The MAX15050/MAX15051 high switching frequency allows the use of ceramic output capacitors. Since the ESR of ceramic capacitors is typically very low, the frequency of the associated transfer function zero is higher than the unity-gain crossover frequency,  $f_C$ , and the zero cannot be used to compensate for the double pole created by the output inductor and capacitor. The double pole produces a gain drop of 40dB/decade and a phase shift of  $180^\circ$ . The compensation network must compensate for this gain drop and phase shift to achieve a stable high-bandwidth closed-loop system. Therefore, use type III compensation as shown in Figure 4 and Figure 5. Type III compensation possesses three poles and two zeros with the first pole,  $f_{P1\_EA}$ , located at zero frequency (DC). Locations of other poles and zeros of the type III compensation are given by:

$$f_{Z1\_EA} = \frac{1}{2\pi \times R1 \times C1}$$

$$f_{Z2\_EA} = \frac{1}{2\pi \times R3 \times C3}$$

# High-Efficiency, 4A, 1MHz, Step-Down Regulators with Integrated Switches in 2mm x 2mm Package

$$f_{p2\_EA} = \frac{1}{2\pi \times R2 \times C3}$$

$$f_{p3\_EA} = \frac{1}{2\pi \times R1 \times C2}$$

The above equations are based on the assumptions that  $C1 \gg C2$ , and  $R3 \gg R2$ , which are true in most applications. Placements of these poles and zeros are determined by the frequencies of the double pole and ESR zero of the power transfer function. It is also a function of the desired closed-loop bandwidth. The following section outlines the step-by-step design procedure to calculate the required compensation components for the MAX15050/MAX15051.

The output voltage is determined by:

$$R4 = \frac{V_{FB} \times R3}{(V_{OUT} - V_{FB})}$$

where  $V_{FB}$  is the feedback voltage equal to  $V_{REFIN/SS}$  or 0.6V depending whether or not an external reference voltage is applied to  $REFIN/SS$ .

For  $V_{OUT} = V_{FB}$ , R4 is not needed.

The zero-cross frequency of the closed-loop,  $f_C$ , should be between 10% and 20% of the switching frequency,  $f_S$  (1MHz). A higher zero-cross frequency results in faster transient response. Once  $f_C$  is chosen, C1 is calculated from the following equation:

$$C1 = \frac{1.5625 \left( \frac{V_{IN}}{V_{P-P}} \right)}{2 \times \pi \times R3 \times \left( 1 + \frac{R_L}{R_O} \right) \times f_C}$$

where  $V_{P-P} = 1V_{P-P}$  (typ).

Due to the underdamped nature of the output LC double pole, set the two zero frequencies of the type III compensation less than the LC double-pole frequency to provide adequate phase boost. Set the two zero frequencies to 80% of the LC double-pole frequency. Hence:

$$R1 = \frac{1}{0.8 \times C1} \times \sqrt{\frac{L \times C_O \times (R_O + ESR)}{R_L + R_O}}$$

$$C3 = \frac{1}{0.8 \times R3} \times \sqrt{\frac{L \times C_O \times (R_O + ESR)}{R_L + R_O}}$$

Setting the second compensation pole,  $f_{p2\_EA}$ , at  $f_{z\_ESR}$  yields:

$$R2 = \frac{C_O \times ESR}{C3}$$

Set the third compensation pole at 1/2 of the switching frequency (500kHz) to gain phase margin. Calculate C2 as follows:

$$C2 = \frac{1}{\pi \times R1 \times f_S}$$

The above equations provide accurate compensation when the zero-cross frequency is significantly higher than the double-pole frequency. When the zero-cross frequency is near the double-pole frequency, the actual zero-cross frequency is higher than the calculated frequency. In this case, lowering the value of R1 reduces the zero-cross frequency. Also, set the third pole of the type III compensation close to the switching frequency (1MHz) if the zero-cross frequency is above 200kHz to boost the phase margin. The recommended range for R3 is 2kΩ to 10kΩ. Note that the loop compensation remains unchanged if only R4's resistance is altered to set different outputs.

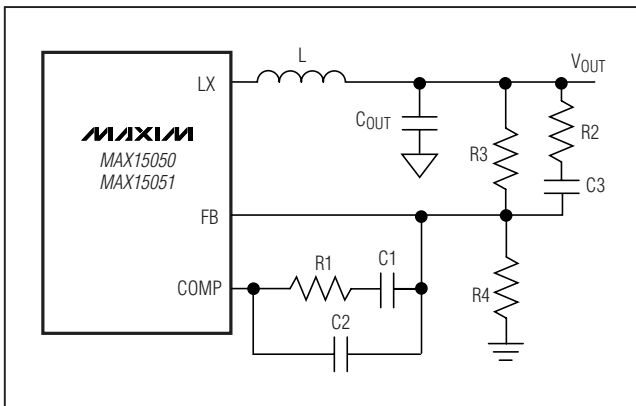

Figure 4. Type III Compensation Network

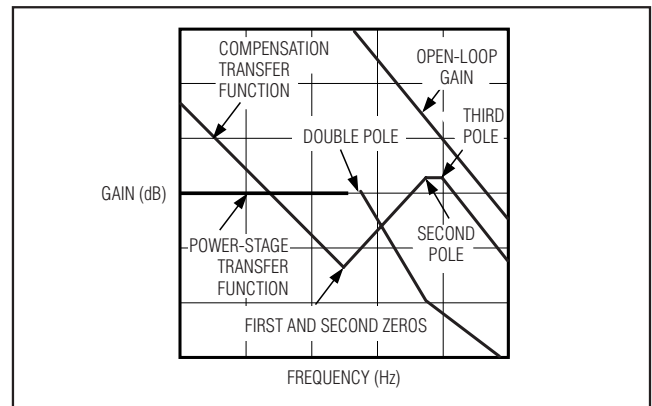

Figure 5. Type III Compensation Illustration

# High-Efficiency, 4A, 1MHz, Step-Down Regulators with Integrated Switches in 2mm x 2mm Package

## Soft-Starting Into a Prebiased Output

The MAX15050/MAX15051 can soft-start into a prebiased output without discharging the output capacitor. In safe prebiased startup, both low-side and high-side switches remain off to avoid discharging the prebiased output. PWM operation starts when the voltage on REFIN/SS crosses the voltage on FB. The PWM activity starts with the low-side switch turning on first to build the bootstrap capacitor charge. Power-good (PWRGD) asserts 48 clock cycles after FB crosses 92.5% of the final regulation set point. After 4096 clock cycles, the MAX15050 switches from prebiased safe-startup mode to either a skip mode or a forced PWM mode depending on whether the inductor current reaches zero. The MAX15051 switches from the prebiased safe-startup mode to forced PWM mode regardless of inductor current level.

The MAX15051 also can start into a prebiased voltage higher than the nominal set point without abruptly discharging the output. This is achieved by using the sink current control of the low-side MOSFET, which has four internally set sinking current-limit thresholds. An internal 4-bit DAC steps through these thresholds, starting from the lowest current limit to the highest, in 128 clock cycles on every power-up.

## PCB Layout Considerations and Thermal Performance

Careful PCB layout is critical to achieve clean and stable operation. It is highly recommended to duplicate the MAX15050/MAX15051 evaluation kit layout for optimum performance. If deviation is necessary, follow these guidelines for good PCB layout:

- 1) Place capacitors on IN, V<sub>DD</sub>, and REFIN/SS as close as possible to the device and the corresponding bump using direct traces.
- 2) Keep the high-current paths as short and wide as possible. Keep the path of switching current short and minimize the loop area formed by LX, the output capacitors, and the input capacitors.
- 3) Connect IN, LX, and GND separately to a large copper area to help cool the device to further improve efficiency and long-term reliability.
- 4) Ensure all feedback connections are short. Place the feedback resistors and compensation components as close to the device as possible.
- 5) Route high-speed switching nodes, such as LX and BST, away from sensitive analog areas (FB, COMP).

## Pin Configuration

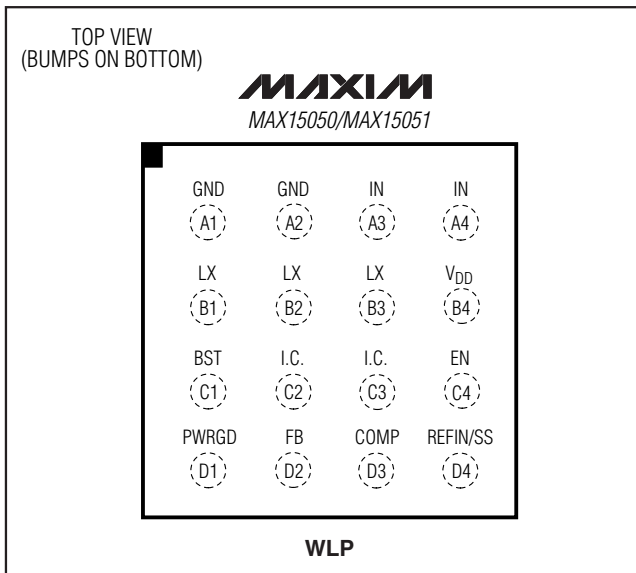

## Chip Information

PROCESS: BiCMOS

## Package Information

For the latest package outline information and land patterns, go to [www.maxim-ic.com/packages](http://www.maxim-ic.com/packages). Note that a "+", "#", or "-" in the package code indicates RoHS status only. Package drawings may show a different suffix character, but the drawing pertains to the package regardless of RoHS status.

PACKAGE TYPE	PACKAGE CODE	OUTLINE NO.	LAND PATTERN NO.
16 WLP	W162C2+1	<a href="#">21-0200</a>	—

# High-Efficiency, 4A, 1MHz, Step-Down Regulators with Integrated Switches in 2mm x 2mm Package

## Revision History

REVISION NUMBER	REVISION DATE	DESCRIPTION	PAGES CHANGED
0	8/09	Initial release.	—
1	10/09	Remove future product asterisk for MAX15051, update <i>Electrical Characteristics</i> table and <i>Typical Operating Characteristics</i> .	1, 2, 4, 5, 6, 12, 14
2	3/10	Revised <i>Absolute Maximum Ratings</i> and <i>Electrical Characteristics</i> table global and note.	2, 3, 4

MAX15050/MAX15051

Maxim cannot assume responsibility for use of any circuitry other than circuitry entirely embodied in a Maxim product. No circuit patent licenses are implied. Maxim reserves the right to change the circuitry and specifications without notice at any time.

Maxim Integrated Products, 120 San Gabriel Drive, Sunnyvale, CA 94086 408-737-7600 \_\_\_\_\_ 15

## Looking for pricing, stock, or lifecycle information?

Click below to explore more details on WIN SOURCE:

 [View MAX15050EWE+T on WIN SOURCE](#)

 [Maxim Integrated](#) Information

## Optimize Your Supply Chain with WIN SOURCE Solutions

-  Global Sourcing Solution
-  Obsolete Management
-  Cost Control Management
-  Shortage Management
-  Alternative Solution
-  Excess Inventory Management