



**THE DATASHEET OF
MAX16060ATE+**





1% Accurate, Quad-/Hex-/Octal-Voltage μ P Supervisors

General Description

The MAX16060/MAX16061/MAX16062 are 1% accurate, quad-/hex-/octal-voltage μ P supervisors in a small thin QFN package. These devices provide supervisory functions for complex multivoltage systems. The MAX16060 monitors four voltages, the MAX16061 monitors six voltages, and the MAX16062 monitors eight voltages.

These devices offer independent outputs for each monitored voltage along with a reset output that asserts whenever any of the monitored voltages fall below their respective thresholds (down to 0.4V) or the manual reset input is asserted. The reset output remains asserted for the reset timeout after all voltages are above their respective thresholds and the manual reset input is deasserted. The minimum reset timeout is internally set to 140ms or can be adjusted with an external capacitor.

All open-drain outputs have internal 30 μ A pullups that eliminate the need for external pullup resistors. However, each output can be driven with an external voltage up to 5.5V. Other features offered include a manual reset input, a tolerance pin for selecting 5% or 10% input thresholds, and a margin enable function for deasserting the outputs during margin testing.

An additional feature is a watchdog timer that asserts $\overline{\text{RESET}}$ when the watchdog timeout period (1.6s typ) is exceeded. The watchdog timer can be disabled by leaving WDI unconnected.

These devices are offered in 16-, 20-, and 24-pin thin QFN packages (4mm x 4mm) and are fully specified from -40°C to +125°C.

Ordering Information

PART	TEMP RANGE	PIN-PACKAGE
MAX16060_TE+	-40°C to +125°C	16 TQFN-EP*
MAX16061_TP+	-40°C to +125°C	20 TQFN-EP*
MAX16062_TG+	-40°C to +125°C	24 TQFN-EP*

Note: The “_” is a placeholder for the input voltage threshold. See Table 1. The MAX16060/MAX16061/MAX16062 are available in factory-preset thresholds/configuration combinations. Choose the desired combination and complete part number from Table 1.

+Denotes a lead-free package.

For tape-and-reel, add a “T” after the “+.” Tape-and-reel are offered in 2.5k increments.

*EP = Exposed pad.

Features

- ◆ Fixed Thresholds for 3.3V, 2.5V, and 1.8V Systems
- ◆ Adjustable Thresholds Monitor Low Voltages (Down to 0.4V)
- ◆ 1% Accurate over Temperature
- ◆ Open-Drain Outputs with Internal Pullups Reduce the Number of External Components
- ◆ Fixed 140ms (min) or Capacitor-Adjustable Reset Timeout
- ◆ Manual Reset, Margin Enable, and Tolerance Select Inputs
- ◆ Watchdog Timer
 - 1.6s (typ) Timeout Period
 - 54s Startup Delay After Reset
- ◆ Monitors Four (MAX16060), Six (MAX16061), or Eight (MAX16062) Voltages
- ◆ $\overline{\text{RESET}}$ Output Indicates All Voltages Present
- ◆ Independent Voltage Monitors
- ◆ Guaranteed to Remain Asserted Down to $V_{CC} = 1V$
- ◆ Small (4mm x 4mm) Thin QFN Package

Applications

Storage Equipment

Multivoltage ASICs

Servers

Automotive

Networking/Telecommunication Equipment

Typical Operating Circuit

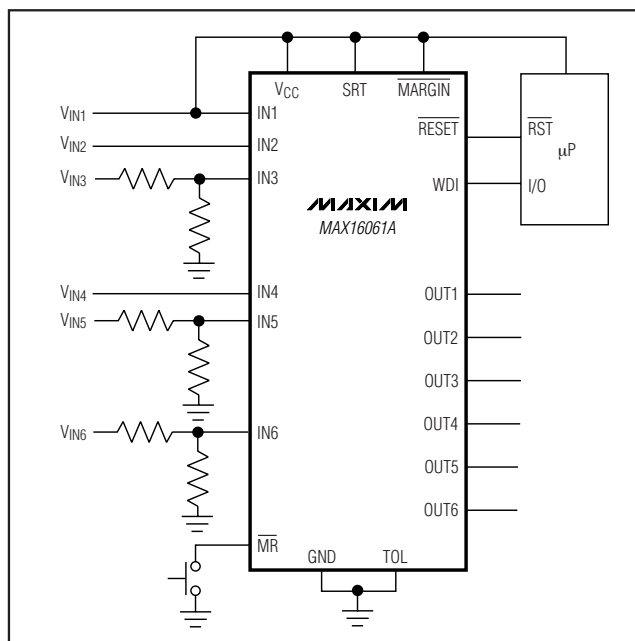

MAX16060/MAX16061/MAX16062

1% Accurate, Quad-/Hex-/Octal-Voltage μ P Supervisors

ABSOLUTE MAXIMUM RATINGS

V_{CC} , OUT_{-} , IN_{-} , $RESET$ to GND	-0.3V to +6V
TOL, MARGIN, MR, SRT, WDI to GND	-0.3V to $V_{CC} + 0.3$
Input/Output Current ($RESET$, MARGIN, SRT, MR, TOL, OUT_{-} , WDI)	± 20 mA
Continuous Power Dissipation ($T_A = +70^{\circ}\text{C}$)	
16-Pin TQFN (derate 16.9mW/ $^{\circ}\text{C}$ above $+70^{\circ}\text{C}$)	1349mW
20-Pin TQFN (derate 16.9mW/ $^{\circ}\text{C}$ above $+70^{\circ}\text{C}$)	1355mW
24-Pin TQFN (derate 16.9mW/ $^{\circ}\text{C}$ above $+70^{\circ}\text{C}$)	1666mW

Operating Temperature Range	-40°C to $+125^{\circ}\text{C}$
Junction Temperature	$+150^{\circ}\text{C}$
Storage Temperature Range	-65°C to $+150^{\circ}\text{C}$
Lead Temperature (soldering, 10s)	$+300^{\circ}\text{C}$

Stresses beyond those listed under "Absolute Maximum Ratings" may cause permanent damage to the device. These are stress ratings only, and functional operation of the device at these or any other conditions beyond those indicated in the operational sections of the specifications is not implied. Exposure to absolute maximum rating conditions for extended periods may affect device reliability.

ELECTRICAL CHARACTERISTICS

($V_{CC} = 2.0\text{V}$ to 5.5V , $T_A = -40^{\circ}\text{C}$ to $+125^{\circ}\text{C}$, unless otherwise specified. Typical values are at $V_{CC} = 3.3\text{V}$, $T_A = +25^{\circ}\text{C}$.) (Note 1)

PARAMETER	SYMBOL	CONDITIONS	MIN	TYP	MAX	UNITS
Operating Voltage Range	V_{CC}	(Note 2)	1.0		5.5	V
Supply Current (Note 3)	I_{CC}	$V_{CC} = 3.3\text{V}$, OUT_{-} , $RESET$ not asserted		45	65	μA
		$V_{CC} = 5\text{V}$, OUT_{-} , $RESET$ not asserted		50	70	
UVLO (Undervoltage Lockout)	V_{UVLO}	V_{CC} rising	1.62	1.80	1.98	V
UVLO Hysteresis	V_{UVLO_HYS}			65		mV
IN₋ (See Table 1)						
Threshold Voltages (IN ₋ Falling)	V_{TH}	3.3V threshold, TOL = GND	3.069	3.102	3.135	V
		3.3V threshold, TOL = V_{CC}	2.904	2.937	2.970	
		2.5V threshold, TOL = GND	2.325	2.350	2.375	
		2.5V threshold, TOL = V_{CC}	2.200	2.225	2.250	
		1.8V threshold, TOL = GND	1.674	1.692	1.710	
		1.8V threshold, TOL = V_{CC}	1.584	1.602	1.620	
Adjustable Threshold (IN ₋ Falling)	V_{TH}	TOL = GND	0.390	0.394	0.398	V
		TOL = V_{CC}	0.369	0.373	0.377	
IN ₋ Hysteresis	V_{TH_HYS}	IN ₋ rising		0.5		% V_{TH}
IN ₋ Input Current		Fixed thresholds		3	16	μA
		Adjustable thresholds	-100		+100	nA

1% Accurate, Quad-/Hex-/Octal-Voltage μP Supervisors

MAX16060/MAX16061/MAX16062

ELECTRICAL CHARACTERISTICS (continued)

($V_{CC} = 2.0V$ to $5.5V$, $T_A = -40^{\circ}C$ to $+125^{\circ}C$, unless otherwise specified. Typical values are at $V_{CC} = 3.3V$, $T_A = +25^{\circ}C$.) (Note 1)

PARAMETER	SYMBOL	CONDITIONS	MIN	TYP	MAX	UNITS
RESET						
Reset Timeout	t_{RP}	$SRT = V_{CC}$	140	200	280	ms
		$C_{SRT} = 1500pF$ (Note 4)	2.43	3.09	3.92	
		$C_{SRT} = 100pF$	0.206			
		$C_{SRT} = \text{open}$	50			μs
SRT Ramp Current	I_{SRT}	$V_{SRT} = 0V$	460	600	740	nA
SRT Threshold			1.173	1.235	1.293	V
SRT Hysteresis				100		mV
IN_{-} to Reset Delay	t_{RD}	IN_{-} falling		20		μs
\overline{RESET} Output-Voltage Low	V_{OL}	$V_{CC} = 3.3V$, $I_{SINK} = 10mA$, \overline{RESET} asserted	0.3			V
		$V_{CC} = 2.5V$, $I_{SINK} = 6mA$, \overline{RESET} asserted	0.3			
		$V_{CC} = 1.2V$, $I_{SINK} = 50\mu A$, \overline{RESET} asserted	0.3			
\overline{RESET} Output-Voltage High	V_{OH}	$V_{CC} \geq 2.0V$, $I_{SOURCE} = 6\mu A$, \overline{RESET} deasserted	$0.8 \times V_{CC}$			V
\overline{MR} Input-Voltage Low	V_{IL}				$0.3 \times V_{CC}$	V
\overline{MR} Input-Voltage High	V_{IH}		$0.7 \times V_{CC}$			V
\overline{MR} Minimum Pulse Width			1			μs
\overline{MR} Glitch Rejection				100		ns
\overline{MR} to Reset Delay				200		ns
\overline{MR} Pullup Resistance		Pulled up to V_{CC}	12	20	28	kΩ
OUTPUTS (OUT_)						
OUT_ Output-Voltage Low	V_{OL}	$V_{CC} = 3.3V$, $I_{SINK} = 2mA$	0.3			V
		$V_{CC} = 2.5V$, $I_{SINK} = 1.2mA$	0.3			
OUT_ Output-Voltage High	V_{OH}	$V_{CC} \geq 2.0V$, $I_{SOURCE} = 6\mu A$	$0.8 \times V_{CC}$			V
IN_{-} to OUT_ Propagation Delay	t_D	($V_{TH} + 100mV$) to ($V_{TH} - 100mV$)		20		μs

1% Accurate, Quad-/Hex-/Octal-Voltage μ P Supervisors

ELECTRICAL CHARACTERISTICS (continued)

($V_{CC} = 2.0V$ to $5.5V$, $T_A = -40^\circ C$ to $+125^\circ C$, unless otherwise specified. Typical values are at $V_{CC} = 3.3V$, $T_A = +25^\circ C$). (Note 1)

PARAMETER	SYMBOL	CONDITIONS	MIN	TYP	MAX	UNITS
WATCHDOG TIMER						
WDI Input-Voltage Low	V_{IL}				$0.3 \times V_{CC}$	V
WDI Input-Voltage High	V_{IH}		$0.7 \times V_{CC}$			V
WDI Pulse Width		(Note 5)	50			ns
Watchdog Timeout Period	t_{WDI}		1.12	1.60	2.40	s
Watchdog Startup Period			35	54	72	s
Watchdog Input Current		$V_{WDI} = 0$ to V_{CC} (Note 5)	-1		+1	μA
DIGITAL LOGIC						
TOL Input-Voltage Low	V_{IL}				$0.3 \times V_{CC}$	V
TOL Input-Voltage High	V_{IH}		$0.7 \times V_{CC}$			V
TOL Input Current		TOL = V_{CC}			100	nA
\overline{MARGIN} Input-Voltage Low	V_{IL}				$0.3 \times V_{CC}$	V
\overline{MARGIN} Input-Voltage High	V_{IH}		$0.7 \times V_{CC}$			V
\overline{MARGIN} Pullup Resistance		Pulled up to V_{CC}	12	20	28	$k\Omega$
\overline{MARGIN} Delay Time	t_{MD}	Rising or falling (Note 6)		50		μs

Note 1: Devices are tested at $T_A = +25^\circ C$ and guaranteed by design for $T_A = T_{MIN}$ to T_{MAX} .

Note 2: The outputs are guaranteed to remain asserted down to $V_{CC} = 1V$.

Note 3: Measured with WDI, \overline{MARGIN} , and \overline{MR} unconnected.

Note 4: The minimum and maximum specifications for this parameter are guaranteed by using the worst case of the SRT ramp current and SRT threshold specifications.

Note 5: Guaranteed by design and not production tested.

Note 6: Amount of time required for logic to lock/unlock outputs from margin testing.

1% Accurate, Quad-/Hex-/Octal-Voltage μ P Supervisors

Typical Operating Characteristics

($V_{CC} = 3.3V$, $T_A = +25^\circ C$, unless otherwise noted.)

MAX16060/MAX16061/MAX16062

SUPPLY CURRENT vs. SUPPLY VOLTAGE

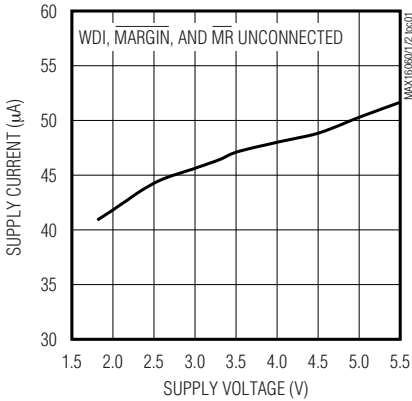

SUPPLY CURRENT vs. TEMPERATURE

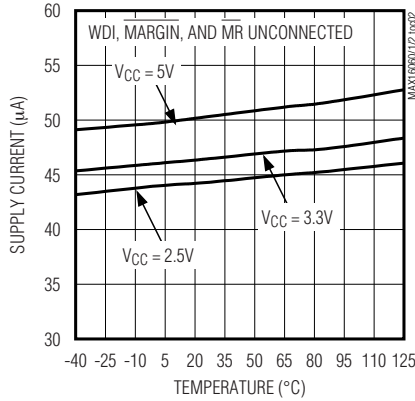

NORMALIZED THRESHOLD vs. SUPPLY VOLTAGE

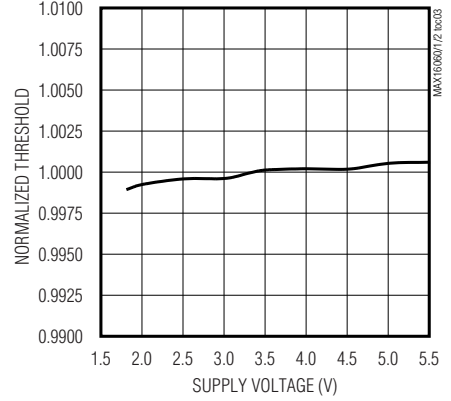

NORMALIZED THRESHOLD vs. TEMPERATURE

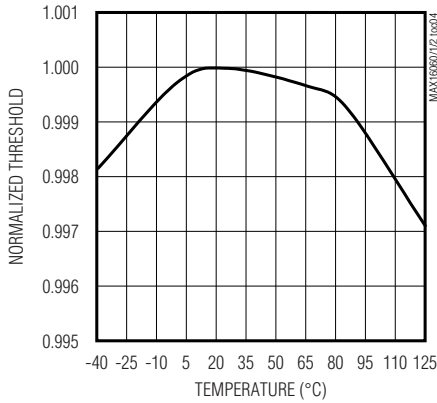

OUTPUT VOLTAGE vs. SINK CURRENT

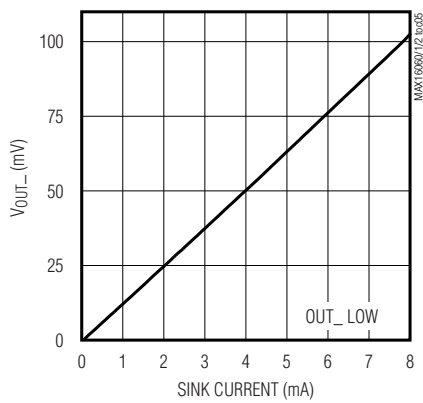

OUTPUT VOLTAGE vs. SOURCE CURRENT

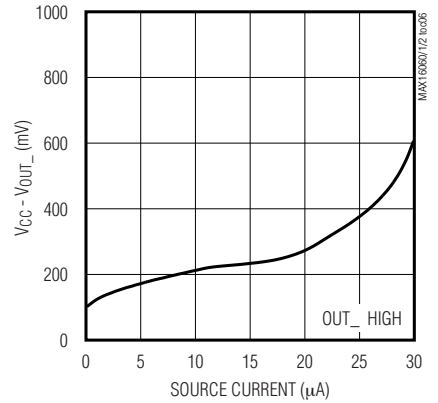

MAXIMUM TRANSIENT DURATION vs. INPUT OVERDRIVE

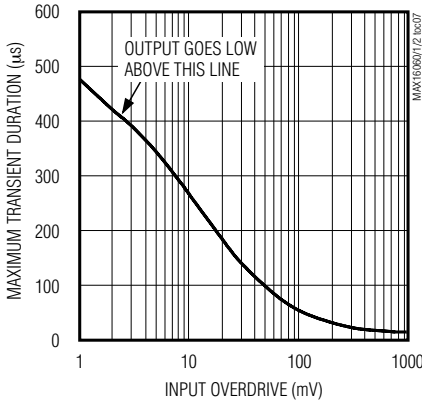

RESET TIMEOUT PERIOD vs. TEMPERATURE

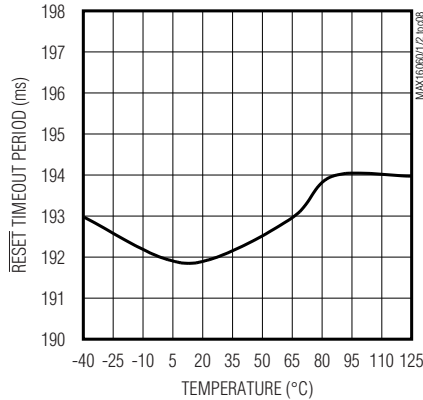

RESET TIMEOUT DELAY

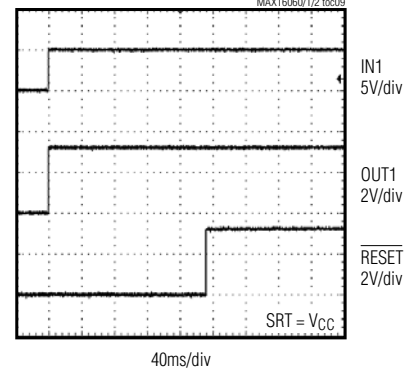

1% Accurate, Quad-/Hex-/Octal-Voltage μ P Supervisors

Typical Operating Characteristics (continued)

($V_{CC} = 3.3V$, $T_A = +25^\circ C$, unless otherwise noted.)

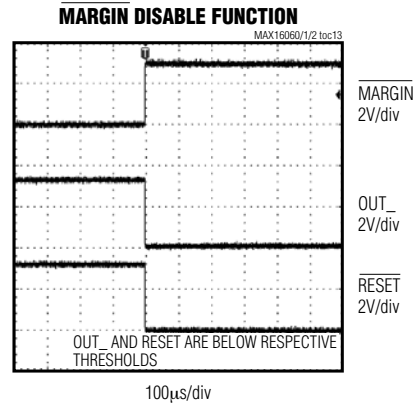
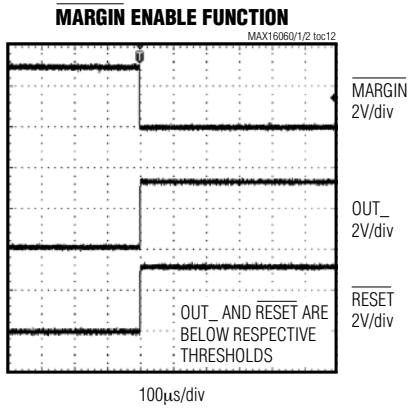
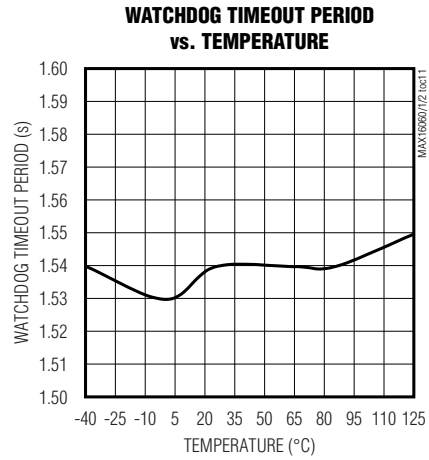
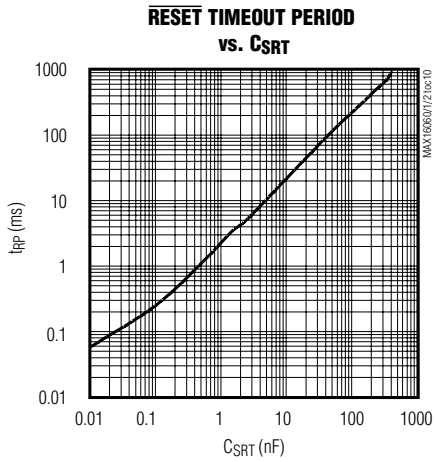

1% Accurate, Quad-/Hex-/Octal-Voltage μP Supervisors

Pin Description (MAX16060)

MAX16060/MAX16061/MAX16062

PIN	NAME	FUNCTION
1	IN3	Monitored Input Voltage 3. See Table 1 for the input voltage threshold.
2	IN4	Monitored Input Voltage 4. See Table 1 for the input voltage threshold.
3	WDI	Watchdog Timer Input. If WDI remains low or high for longer than the watchdog timeout period, $\overline{\text{RESET}}$ is asserted. The timer clears whenever a reset is asserted or a rising or falling edge on WDI is detected. The watchdog timer enters a startup period that allows 54s for the first transition to occur before a reset. Leave WDI unconnected to disable the watchdog timer. The WDI unconnected-state detector uses a small 400nA current. Therefore, do not connect WDI to anything that will source or sink more than 200nA. Note that the leakage current specification for most three-state drivers exceeds 200nA.
4	GND	Ground
5	VCC	Unmonitored Power-Supply Input
6	OUT3	Output 3. When the voltage at IN3 falls below its threshold, OUT3 goes low and stays low until the voltage at IN3 exceeds its threshold. The open-drain output has a 30μA internal pullup to VCC.
7	OUT4	Output 4. When the voltage at IN4 falls below its threshold, OUT4 goes low and stays low until the voltage at IN4 exceeds its threshold. The open-drain output has a 30μA internal pullup to VCC.
8	$\overline{\text{MR}}$	Active-Low Manual Reset Input. Pull $\overline{\text{MR}}$ low to assert $\overline{\text{RESET}}$ low. $\overline{\text{RESET}}$ remains low for the reset timeout period after $\overline{\text{MR}}$ is deasserted. $\overline{\text{MR}}$ is pulled up to VCC through a 20kΩ resistor.
9	SRT	Set Reset Timeout Input. Connect a capacitor from SRT to GND to set the reset timeout period. The reset timeout period can be calculated as follows: Reset Timeout (s) = $2.06 \times 10^6 (\Omega) \times \text{CSRT (F)}$. For the internal timeout period of 140ms (min), connect SRT to VCC.
10	$\overline{\text{MARGIN}}$	Active-Low Manual Deassert Input. Pull $\overline{\text{MARGIN}}$ low to deassert all outputs (go into high state), regardless of the voltage at any monitored input.
11	OUT2	Output 2. When the voltage at IN2 falls below its threshold, OUT2 goes low and stays low until the voltage at IN2 exceeds its threshold. The open-drain output has a 30μA internal pullup to VCC.
12	OUT1	Output 1. When the voltage at IN1 falls below its threshold, OUT1 goes low and stays low until the voltage at IN1 exceeds its threshold. The open-drain output has a 30μA internal pullup to VCC.
13	$\overline{\text{RESET}}$	Active-Low Reset Output. $\overline{\text{RESET}}$ asserts low when any of the monitored voltages falls below its respective threshold or $\overline{\text{MR}}$ is asserted. $\overline{\text{RESET}}$ remains asserted for the reset timeout period after all monitored voltages exceed their respective thresholds and $\overline{\text{MR}}$ is deasserted. This open-drain output has a 30μA internal pullup.
14	IN1	Monitored Input Voltage 1. See Table 1 for the input voltage threshold.
15	IN2	Monitored Input Voltage 2. See Table 1 for the input voltage threshold.
16	TOL	Threshold Tolerance Input. Connect TOL to GND to select 5% threshold tolerance. Connect TOL to VCC to select 10% threshold tolerance.
—	EP	Exposed Pad. EP is internally connected to GND. Connect EP to the ground plane to provide a low thermal resistance path from the IC junction to the PCB. Do not use as the electrical connection to GND.

1% Accurate, Quad-/Hex-/Octal-Voltage μ P Supervisors

Pin Description (MAX16061)

PIN	NAME	FUNCTION
1	IN4	Monitored Input Voltage 4. See Table 1 for the input voltage threshold.
2	IN5	Monitored Input Voltage 5. See Table 1 for the input voltage threshold.
3	IN6	Monitored Input Voltage 6. See Table 1 for the input voltage threshold.
4	WDI	Watchdog Timer Input. If WDI remains low or high for longer than the watchdog timeout period, $\overline{\text{RESET}}$ is asserted and the timer is cleared. The timer also clears whenever a reset is asserted or a rising or falling edge on WDI is detected. The watchdog timer enters a startup period that allows 54s for the first transition to occur before a reset. Leave WDI unconnected to disable the watchdog timer. The WDI unconnected-state detector uses a small 400nA current. Therefore, do not connect WDI to anything that will source or sink more than 200nA. Note that the leakage current specification for most three-state drivers exceeds 200nA.
5	GND	Ground
6	VCC	Unmonitored Power-Supply Input
7	OUT4	Output 4. When the voltage at IN4 falls below its threshold, OUT4 goes low and stays low until the voltage at IN4 exceeds its threshold. The open-drain output has a 30 μ A internal pullup to VCC.
8	OUT5	Output 5. When the voltage at IN5 falls below its threshold, OUT5 goes low and stays low until the voltage at IN5 exceeds its threshold. The open-drain output has a 30 μ A internal pullup to VCC.
9	OUT6	Output 6. When the voltage at IN6 falls below its threshold, OUT6 goes low and stays low until the voltage at IN6 exceeds its threshold. The open-drain output has a 30 μ A internal pullup to VCC.
10	$\overline{\text{MR}}$	Active-Low Manual Reset Input. Pull $\overline{\text{MR}}$ low to assert $\overline{\text{RESET}}$ low. $\overline{\text{RESET}}$ remains low for the reset timeout period after $\overline{\text{MR}}$ is deasserted. $\overline{\text{MR}}$ is pulled up to VCC through a 20k Ω resistor.
11	SRT	Set Reset Timeout Input. Connect a capacitor from SRT to GND to set the reset timeout period. The reset timeout period can be calculated as follows: Reset Timeout (s) = 2.06 x 10 ⁶ (Ω) x CSRT (F). For the internal timeout period of 140ms (min), connect SRT to VCC.
12	$\overline{\text{MARGIN}}$	Manual Deassert Input. Pull $\overline{\text{MARGIN}}$ low to deassert all outputs (go into high state), regardless of the voltage at any monitored input.
13	OUT3	Output 3. When the voltage at IN3 falls below its threshold, OUT3 goes low and stays low until the voltage at IN3 exceeds its threshold. The open-drain output has a 30 μ A internal pullup to VCC.
14	OUT2	Output 2. When the voltage at IN2 falls below its threshold, OUT2 goes low and stays low until the voltage at IN2 exceeds its threshold. The open-drain output has a 30 μ A internal pullup to VCC.
15	OUT1	Output 1. When the voltage at IN1 falls below its threshold, OUT1 goes low and stays low until the voltage at IN1 exceeds its threshold. The open-drain output has a 30 μ A internal pullup to VCC.
16	$\overline{\text{RESET}}$	Active-Low Reset Output. $\overline{\text{RESET}}$ asserts low when any of the monitored voltages falls below its respective threshold or $\overline{\text{MR}}$ is asserted. $\overline{\text{RESET}}$ remains asserted for the reset timeout period after all monitored voltages exceed their respective thresholds and $\overline{\text{MR}}$ is deasserted. This open-drain output has a 30 μ A internal pullup.
17	IN1	Monitored Input Voltage 1. See Table 1 for the input voltage threshold.
18	IN2	Monitored Input Voltage 2. See Table 1 for the input voltage threshold.
19	IN3	Monitored Input Voltage 3. See Table 1 for the input voltage threshold.
20	TOL	Threshold Tolerance Input. Connect TOL to GND to select 5% threshold tolerance. Connect TOL to VCC to select 10% threshold tolerance.
—	EP	Exposed Pad. EP is internally connected to GND. Connect EP to the ground plane to provide a low thermal resistance path from the IC junction to the PCB. Do not use as the electrical connection to GND.

1% Accurate, Quad-/Hex-/Octal-Voltage μP Supervisors

Pin Description (MAX16062)

MAX16060/MAX16061/MAX16062

PIN	NAME	FUNCTION
1	IN5	Monitored Input Voltage 5. See Table 1 for the input voltage threshold.
2	IN6	Monitored Input Voltage 6. See Table 1 for the input voltage threshold.
3	IN7	Monitored Input Voltage 7. See Table 1 for the input voltage threshold.
4	IN8	Monitored Input Voltage 8. See Table 1 for the input voltage threshold.
5	WDI	Watchdog Timer Input. If WDI remains low or high for longer than the watchdog timeout period, $\overline{\text{RESET}}$ is asserted and the timer is cleared. The timer also clears whenever a reset is asserted or a rising or falling edge on WDI is detected. The watchdog timer enters a startup period that allows 54s for the first transition to occur before a reset. Leave WDI unconnected to disable the watchdog timer. The WDI unconnected state detector uses a small 400nA current. Therefore, do not connect WDI to anything that will source or sink more than 200nA. Note that the leakage current specification for most three-state drivers exceeds 200nA.
6	GND	Ground
7	V _{CC}	Unmonitored Power-Supply Input
8	OUT5	Output 5. When the voltage at IN5 falls below its threshold, OUT5 goes low and stays low until the voltage at IN5 exceeds its threshold. The open-drain output has a 30μA internal pullup to V _{CC} .
9	OUT6	Output 6. When the voltage at IN6 falls below its threshold, OUT6 goes low and stays low until the voltage at IN6 exceeds its threshold. The open-drain output has a 30μA internal pullup to V _{CC} .
10	OUT7	Output 7. When the voltage at IN7 falls below its threshold, OUT7 goes low and stays low until the voltage at IN7 exceeds its threshold. The open-drain output has a 30μA internal pullup to V _{CC} .
11	OUT8	Output 8. When the voltage at IN8 falls below its threshold, OUT8 goes low and stays low until the voltage at IN8 exceeds its threshold. The open-drain output has a 30μA internal pullup to V _{CC} .
12	$\overline{\text{MR}}$	Active-Low Manual Reset Input. Pull $\overline{\text{MR}}$ low to assert $\overline{\text{RESET}}$ low. $\overline{\text{RESET}}$ remains low for the reset timeout period after $\overline{\text{MR}}$ is deasserted. $\overline{\text{MR}}$ is pulled up to V _{CC} through a 20kΩ resistor.
13	SRT	Set Reset Timeout Input. Connect a capacitor from SRT to GND to set the reset timeout period. The reset timeout period can be calculated as follows: Reset Timeout (s) = $2.06 \times 10^6 (\Omega) \times C_{\text{SRT}} (\text{F})$. For the internal timeout period of 140ms (min), connect SRT to V _{CC} .
14	$\overline{\text{MARGIN}}$	Margin Disable Input. Pull $\overline{\text{MARGIN}}$ low to deassert all outputs (go into high state), regardless of the voltage at any monitored input.
15	OUT4	Output 4. When the voltage at IN4 falls below its threshold, OUT4 goes low and stays low until the voltage at IN4 exceeds its threshold. The open-drain output has a 30μA internal pullup to V _{CC} .
16	OUT3	Output 3. When the voltage at IN3 falls below its threshold, OUT3 goes low and stays low until the voltage at IN3 exceeds its threshold. The open-drain output has a 30μA internal pullup to V _{CC} .
17	OUT2	Output 2. When the voltage at IN2 falls below its threshold, OUT2 goes low and stays low until the voltage at IN2 exceeds its threshold. The open-drain output has a 30μA internal pullup to V _{CC} .
18	OUT1	Output 1. When the voltage at IN1 falls below its threshold, OUT1 goes low and stays low until the voltage at IN1 exceeds its threshold. The open-drain output has a 30μA internal pullup to V _{CC} .
19	$\overline{\text{RESET}}$	Active-Low Reset Output. $\overline{\text{RESET}}$ asserts low when any of the monitored voltages falls below its respective threshold or $\overline{\text{MR}}$ is asserted. $\overline{\text{RESET}}$ remains asserted for the reset timeout period after all monitored voltages exceed their respective thresholds and $\overline{\text{MR}}$ is deasserted. This open-drain output has a 30μA internal pullup.
20	IN1	Monitored Input Voltage 1. See Table 1 for the input voltage threshold.
21	IN2	Monitored Input Voltage 2. See Table 1 for the input voltage threshold.
22	IN3	Monitored Input Voltage 3. See Table 1 for the input voltage threshold.
23	IN4	Monitored Input Voltage 4. See Table 1 for the input voltage threshold.
24	TOL	Threshold Tolerance Input. Connect TOL to GND to select 5% threshold tolerance. Connect TOL to V _{CC} to select 10% threshold tolerance.
—	EP	Exposed Pad. EP is internally connected to GND. Connect EP to the ground plane to provide a low thermal resistance path from the IC junction to the PCB. Do not use as the electrical connection to GND.

1% Accurate, Quad-/Hex-/Octal-Voltage μP Supervisors

Table 1. Input-Voltage-Threshold Selector

PART	IN1	IN2	IN3	IN4	IN5	IN6	IN7	IN8
MAX16060A	3.3	2.5	ADJ	1.8	—	—	—	—
MAX16060B	3.3	ADJ	ADJ	1.8	—	—	—	—
MAX16060C	ADJ	2.5	ADJ	1.8	—	—	—	—
MAX16060D	3.3	2.5	ADJ	ADJ	—	—	—	—
MAX16060E	ADJ	ADJ	ADJ	ADJ	—	—	—	—
MAX16061A	3.3	2.5	ADJ	1.8	ADJ	ADJ	—	—
MAX16061B	3.3	ADJ	ADJ	1.8	ADJ	ADJ	—	—
MAX16061C	3.3	2.5	ADJ	ADJ	ADJ	ADJ	—	—
MAX16061D	ADJ	2.5	ADJ	1.8	ADJ	ADJ	—	—
MAX16061E	ADJ	ADJ	ADJ	ADJ	ADJ	ADJ	—	—
MAX16062A	3.3	2.5	ADJ	1.8	ADJ	ADJ	ADJ	ADJ
MAX16062B	3.3	ADJ	ADJ	1.8	ADJ	ADJ	ADJ	ADJ
MAX16062C	3.3	2.5	ADJ	ADJ	ADJ	ADJ	ADJ	ADJ
MAX16062D	ADJ	2.5	ADJ	1.8	ADJ	ADJ	ADJ	ADJ
MAX16062E	ADJ	ADJ	ADJ	ADJ	ADJ	ADJ	ADJ	ADJ

Note: Other fixed thresholds may be available. Contact factory for availability.

1% Accurate, Quad-/Hex-/Octal-Voltage μ P Supervisors

Functional Diagrams

MAX16060/MAX16061/MAX16062

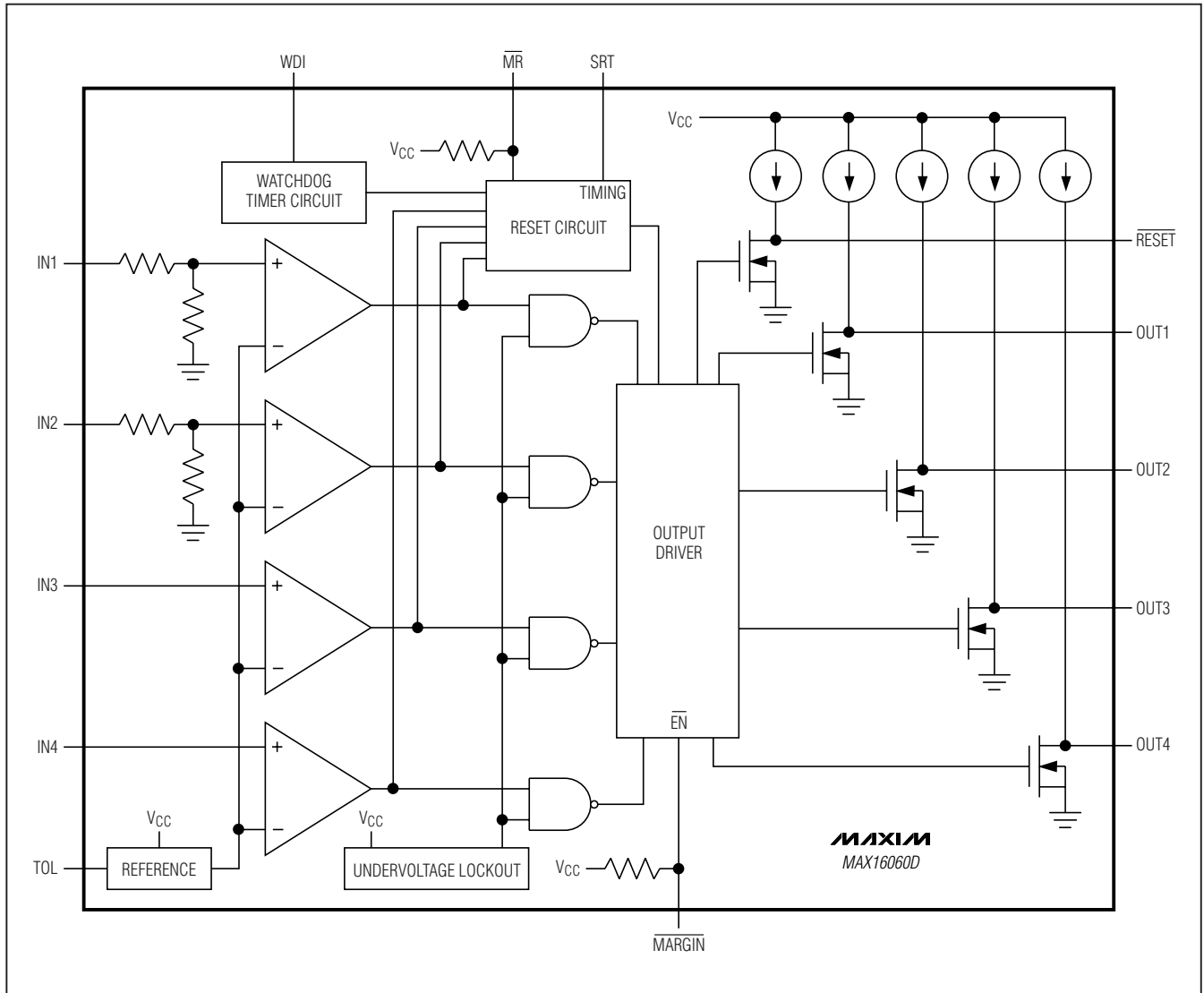

Figure 1. MAX16060D Functional Diagram

1% Accurate, Quad-/Hex-/Octal-Voltage μ P Supervisors

Functional Diagrams (continued)

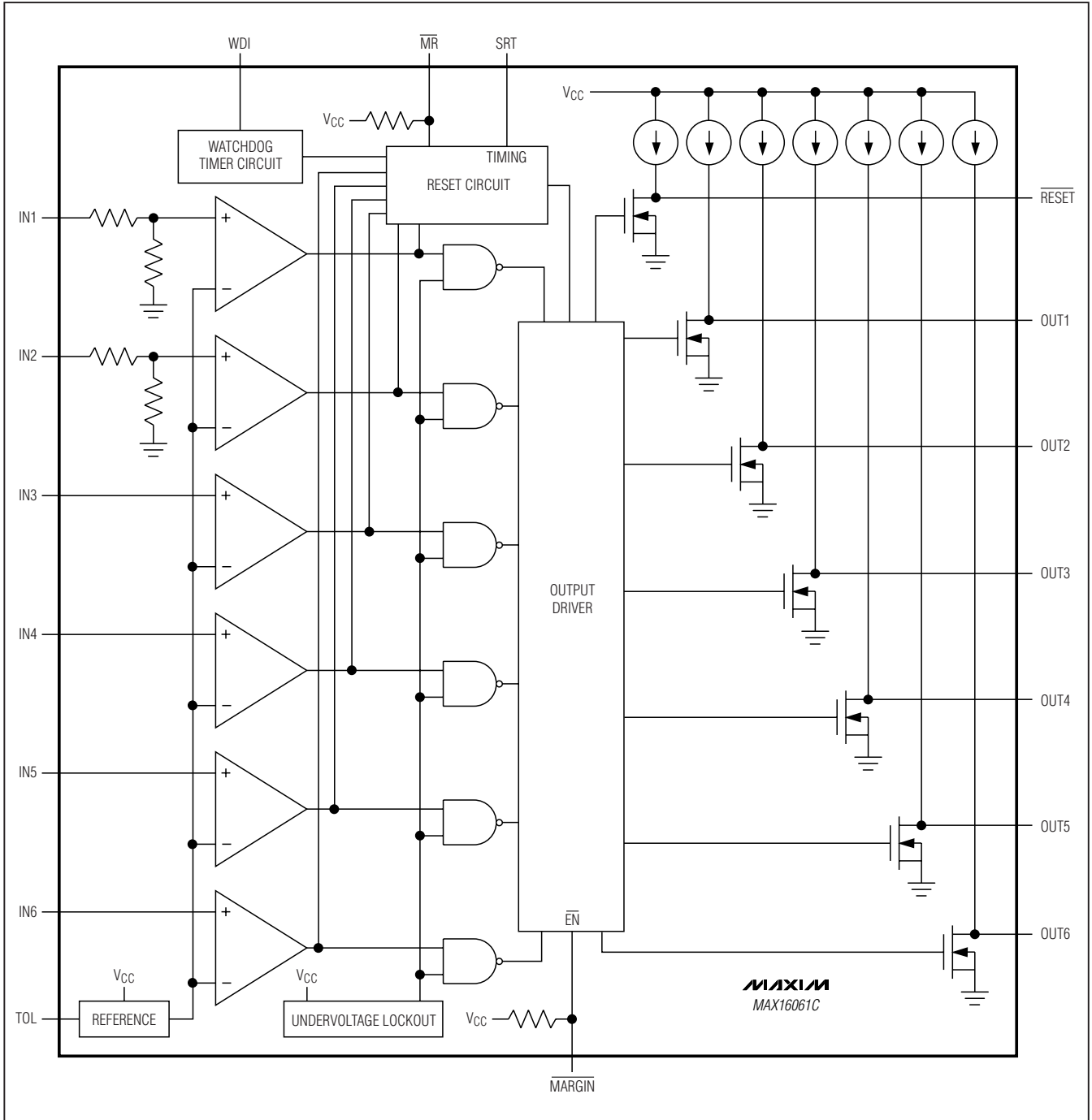

Figure 2. MAX16061C Functional Diagram

1% Accurate, Quad-/Hex-/Octal-Voltage μ P Supervisors

Functional Diagrams (continued)

MAX16060/MAX16061/MAX16062

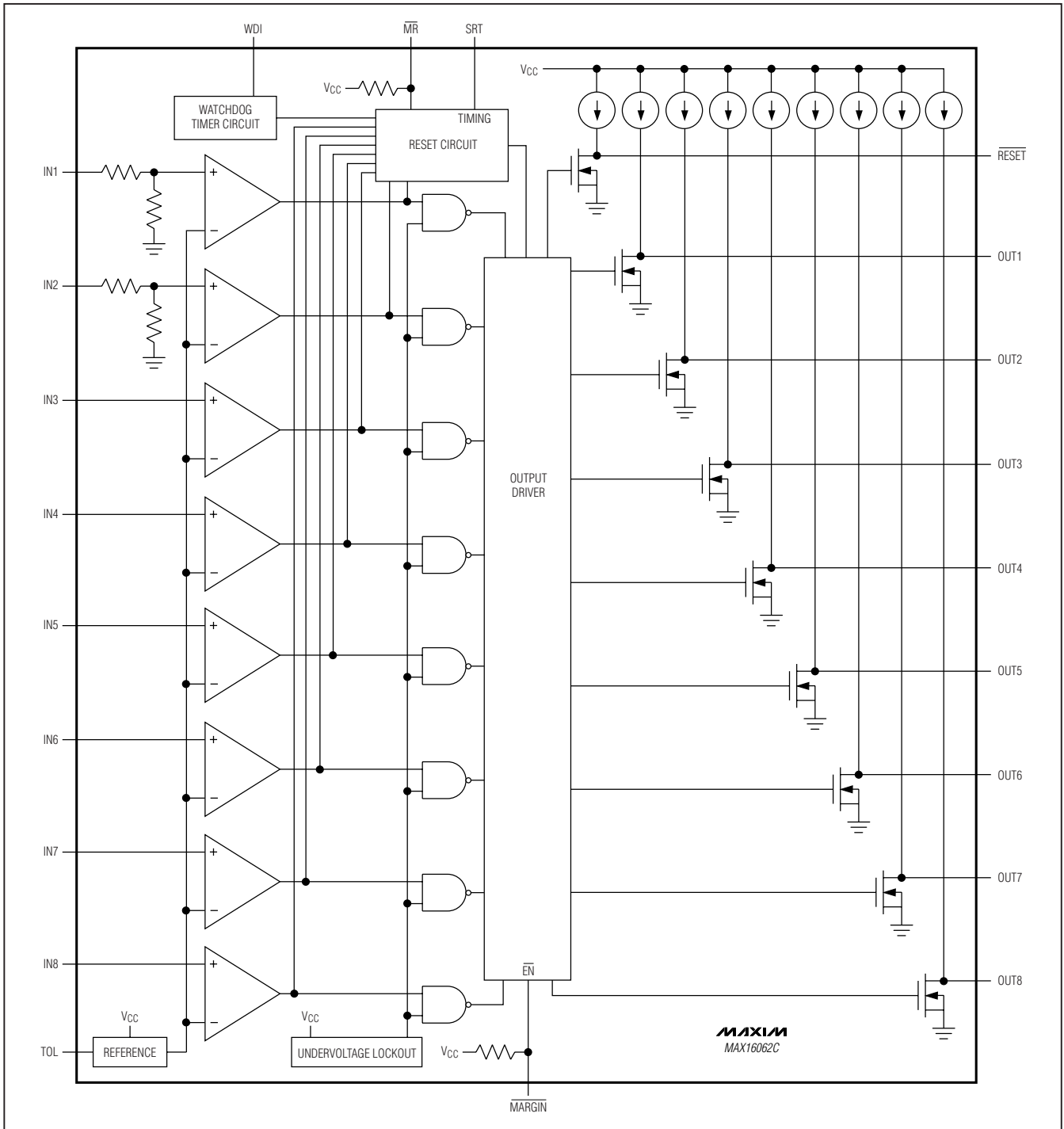

Figure 3. MAX16062C Functional Diagram

1% Accurate, Quad-/Hex-/Octal-Voltage μ P Supervisors

Detailed Description

The MAX16060/MAX16061/MAX16062 are 1% accurate low-voltage, quad-/hex-/octal-voltage μ P supervisors in a small thin QFN package. These devices provide supervisory functions for complex multivoltage systems. The MAX16060 monitors four voltages; the MAX16061 monitors six voltages; and the MAX16062 monitors eight voltages.

These supervisors offer independent outputs for each monitored voltage along with a reset output that asserts whenever any of the monitored voltages fall below their respective thresholds or the manual reset input is asserted. The reset output remains asserted for the reset timeout after all voltages are above their respective thresholds and the manual reset input is deasserted. The minimum reset timeout is internally set to 140ms or can be adjusted with an external capacitor.

All open-drain outputs have internal 30 μ A pullups that eliminate the need for external pullup resistors. However, each output can be driven with an external voltage up to 5.5V. Other features offered include a manual reset input, a tolerance pin for selecting 5% or 10% input thresholds, and a margin enable function for deasserting the outputs during margin testing.

An additional feature is a watchdog timer that asserts $\overline{\text{RESET}}$ when the watchdog timeout period (1.6s typ) is exceeded. The watchdog timer can be disabled by leaving WDI unconnected.

Applications Information

Undervoltage-Detection Circuit

The open-drain outputs of the MAX16060/MAX16061/MAX16062 can be configured to detect an undervoltage condition. Figure 4 shows a configuration where an LED turns on when the comparator output is low, indicating an undervoltage condition. These devices can also be used in applications such as system supervisory monitoring, multivoltage level detection, and VCC bar-graph monitoring (Figure 5).

Tolerance (TOL)

The MAX16060/MAX16061/MAX16062 feature a pin-selectable threshold tolerance. Connect TOL to GND to select 5% threshold tolerance. Connect TOL to VCC to select 10% threshold tolerance.

Window Detection

A window detector circuit uses two inputs in the configuration shown in Figure 6. External resistors set the two threshold voltages of the window detector circuit. External logic gates create the OUT signal. The window detection width is the difference between the threshold voltages (Figure 7).

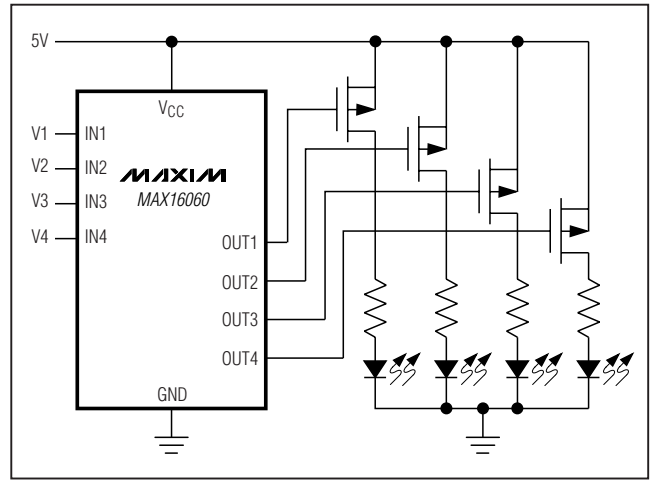

Figure 4. Quad Undervoltage Detector with LED Indicators

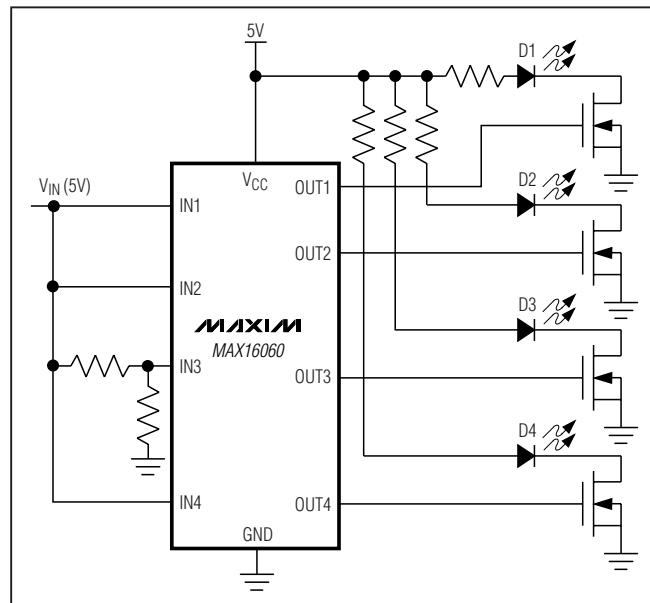

Figure 5. VCC Bar-Graph Monitoring

1% Accurate, Quad-/Hex-/Octal-Voltage μ P Supervisors

MAX16060/MAX16061/MAX16062

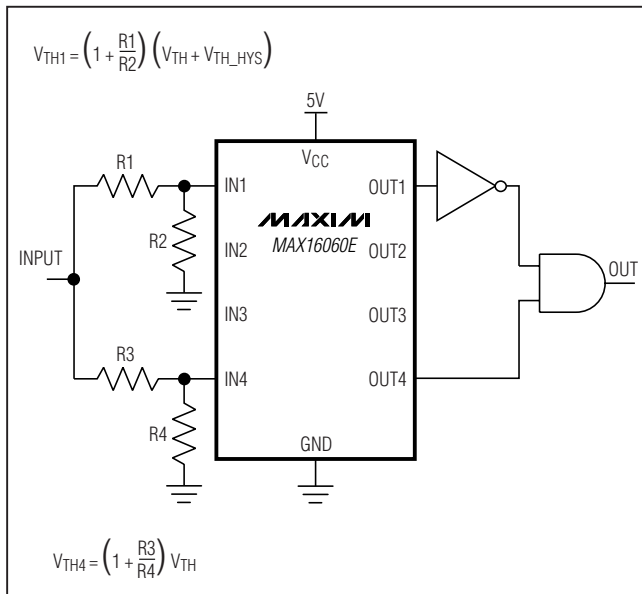

Figure 6. Window Detection

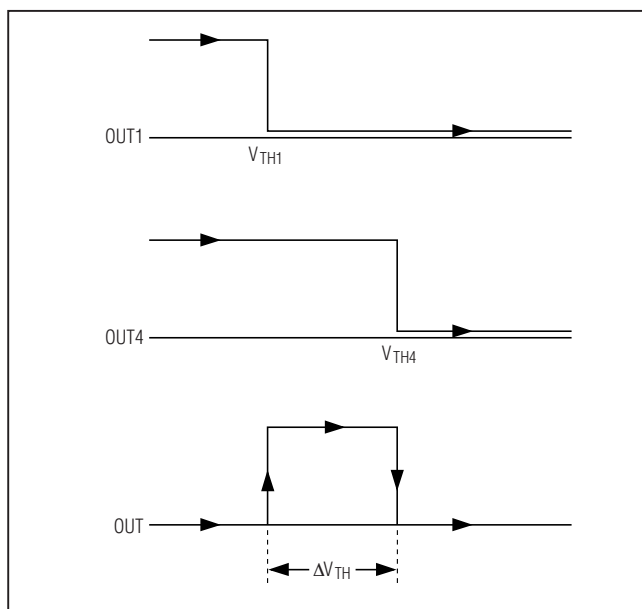

Figure 7. Output Response of Window Detector Circuit

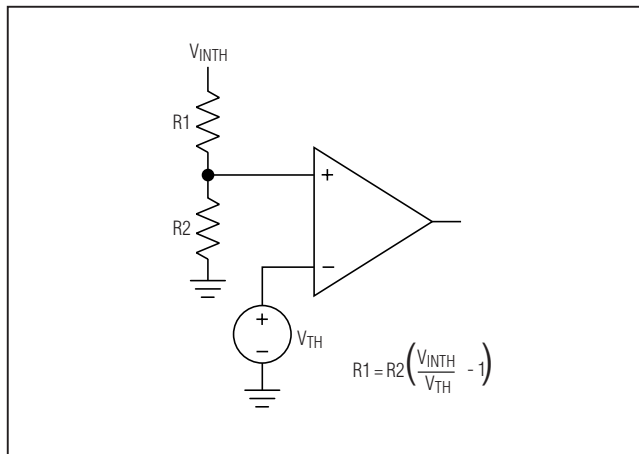

Figure 8. Setting the Adjustable Input

Adjustable Input

These devices offer several monitor options with adjustable input thresholds (see Table 1). The threshold voltage at each adjustable IN_ input is typically 0.394V (TOL = GND) or 0.373V (TOL = V_{CC}). To monitor a voltage V_{INTH}, connect a resistive-divider network to the circuit as shown in Figure 8.

$$V_{INTH} = V_{TH} \left(\frac{R1}{R2} + 1\right)$$

$$R1 = R2 \left(\frac{V_{INTH}}{V_{TH}} - 1\right)$$

Large resistors can be used to minimize current through the external resistors. For greater accuracy, use lower-value resistors.

Unused Inputs

Connect any unused IN_ inputs to a voltage above its threshold.

OUT_ Outputs

The OUT_ outputs go low when their respective IN_ inputs drop below their specified thresholds. The output is open drain with a 30 μ A internal pullup to V_{CC}. For many applications, no external pullup resistor is required to interface with other logic devices. An external pullup resistor to any voltage from 0 to 5.5V overrides the internal pullup if interfacing to different logic supply voltages. Internal circuitry prevents reverse current flow from the external pullup voltage to V_{CC} (Figure 9).

1% Accurate, Quad-/Hex-/Octal-Voltage μ P Supervisors

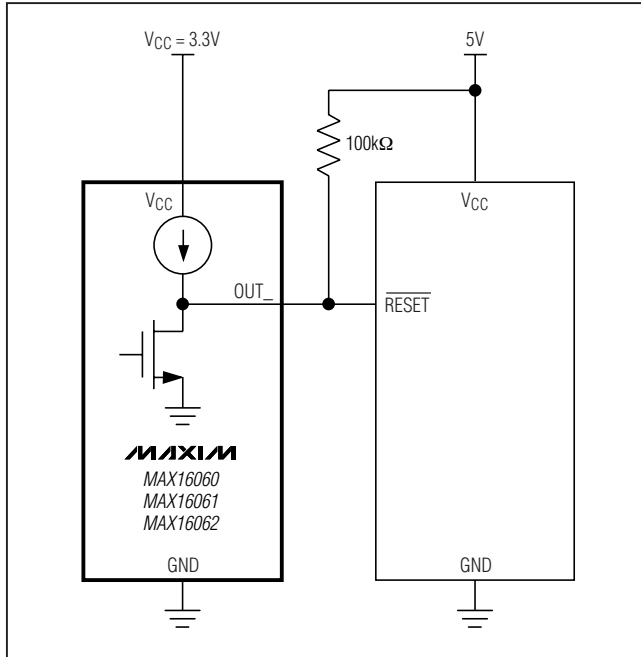

Figure 9. Interfacing to a Different Logic Supply Voltage

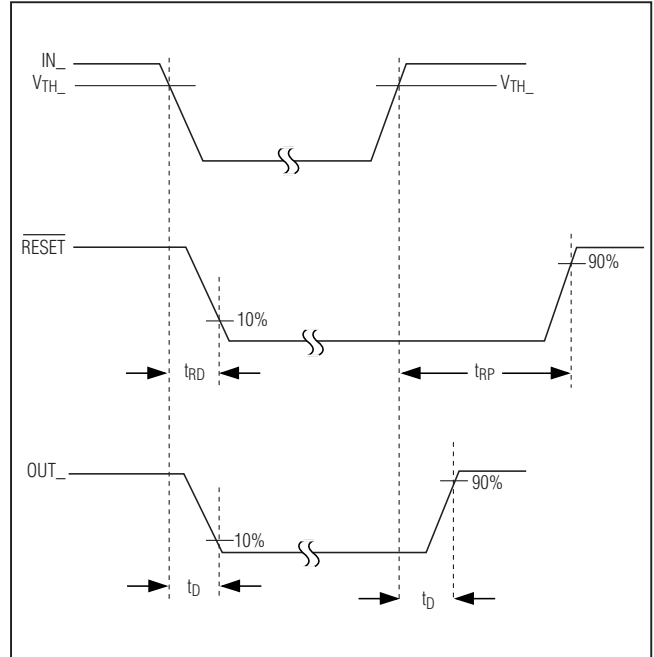

Figure 10. Output Timing Diagram

RESET Output

RESET asserts low when any of the monitored voltages fall below their respective thresholds or MR is asserted. RESET remains asserted for the reset timeout period after all monitored voltages exceed their respective thresholds and MR is deasserted (see Figure 10). This open-drain output has a 30 μ A internal pullup. An external pullup resistor to any voltage from 0 to 5.5V overrides the internal pullup if interfacing to different logic supply voltages. Internal circuitry prevents reverse current flow from the external pullup voltage to VCC (Figure 9).

Reset Timeout Capacitor

The reset timeout period can be adjusted to accommodate a variety of μ P applications. Adjust the reset timeout period (t_{RP}) by connecting a capacitor (C_{SRT}) between SRT and GND. Calculate the reset timeout capacitor as follows:

$$C_{SRT}(F) = \frac{t_{RP}(s) \times I_{SRT}}{V_{TH_SRT}}$$

Connect SRT to VCC for a factory-programmed reset timeout of 140ms (min).

Manual Reset Input (MR)

Many μ P-based products require manual reset capability, allowing the operator, a test technician, or external logic circuitry to initiate a reset. A logic-low on MR asserts RESET low. RESET remains asserted while MR is low, and during the reset timeout period (140ms min) after MR returns high. The MR input has an internal 20k Ω pullup resistor to VCC, so it can be left unconnected if not used. MR can be driven with TTL or CMOS-logic levels, or with open-drain/collector outputs. Connect a normally open momentary switch from MR to GND to create a manual reset function. External debounce circuitry is not required. If MR is driven from long cables or if the device is used in a noisy environment, connecting a 0.1 μ F capacitor from MR to GND provides additional noise immunity.

1% Accurate, Quad-/Hex-/Octal-Voltage μ P Supervisors

Margin Output Disable ($\overline{\text{MARGIN}}$)

$\overline{\text{MARGIN}}$ allows system-level testing while power supplies are adjusted from their nominal voltages. Drive $\overline{\text{MARGIN}}$ low to force $\overline{\text{RESET}}$ and OUT_n high, regardless of the voltage at any monitored input. The state of each output does not change while $\overline{\text{MARGIN}} = \text{GND}$. The watchdog timer continues to run when $\overline{\text{MARGIN}}$ is low, and if a timeout occurs, $\overline{\text{RESET}}$ will assert t_{MD} after $\overline{\text{MARGIN}}$ is deasserted.

The $\overline{\text{MARGIN}}$ input is internally pulled up to V_{CC} . Leave $\overline{\text{MARGIN}}$ unconnected or connect to V_{CC} if unused.

Undervoltage Lockout (UVLO)

The MAX16060/MAX16061/MAX16062 feature a V_{CC} undervoltage lockout (UVLO) that preserves a reset status even if V_{CC} falls as low as 1V. The undervoltage lockout circuitry monitors the voltage at V_{CC} . If V_{CC} falls below the UVLO falling threshold (typically

1.735V), $\overline{\text{RESET}}$ is asserted and all OUT_n are asserted low. This eliminates an incorrect $\overline{\text{RESET}}$ or OUT_n output state as V_{CC} drops below the normal V_{CC} operational voltage range of 1.98V to 5.5V.

During power-up as V_{CC} rises above 1V, $\overline{\text{RESET}}$ is asserted and all OUT_n are asserted low until V_{CC} exceeds the UVLO threshold. As V_{CC} exceeds the UVLO threshold, all inputs are monitored and the correct output state appears at all the outputs. This also ensures that $\overline{\text{RESET}}$ and all OUT_n are in the correct state once V_{CC} reaches the normal V_{CC} operational range.

Power-Supply Bypassing

In noisy applications, bypass V_{CC} to ground with a 0.1 μ F capacitor as close to the device as possible. The additional capacitor improves transient immunity. For fast-rising V_{CC} transients, additional capacitance may be required.

MAX16060/MAX16061/MAX16062

1% Accurate, Quad-/Hex-/Octal-Voltage μ P Supervisors

Pin Configurations

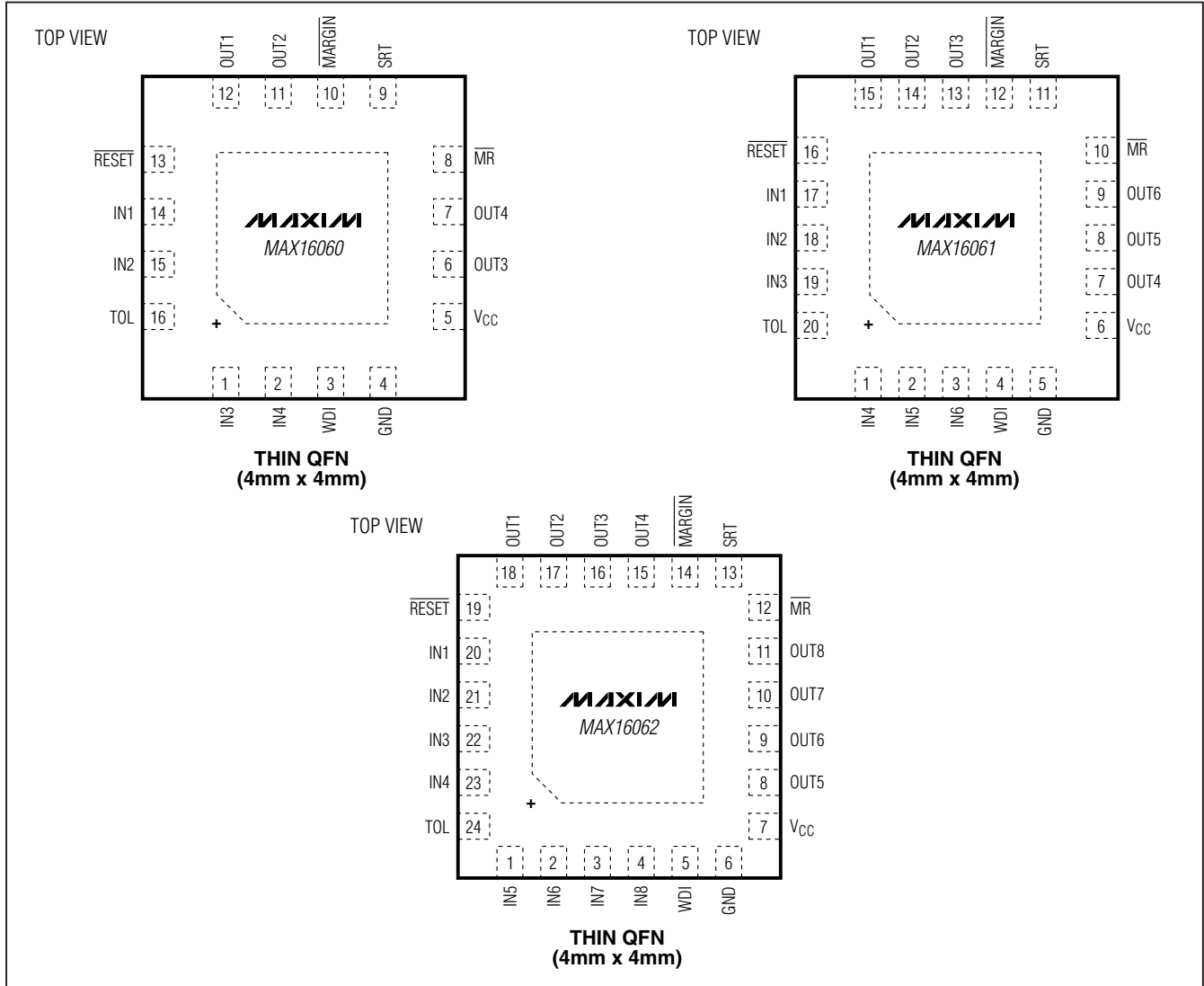

Chip Information

PROCESS: BiCMOS

Package Information

For the latest package outline information, go to www.maxim-ic.com/packages.

PACKAGE TYPE	PACKAGE CODE	DOCUMENT NO.
16 TQFN	T1644-4	21-0139
20 TQFN	T2044-3	21-0139
24 TQFN	T2444-4	21-0139

Maxim cannot assume responsibility for use of any circuitry other than circuitry entirely embodied in a Maxim product. No circuit patent licenses are implied. Maxim reserves the right to change the circuitry and specifications without notice at any time.

18 **Maxim Integrated Products, 120 San Gabriel Drive, Sunnyvale, CA 94086 408-737-7600**

Looking for pricing, stock, or lifecycle information?

Click below to explore more details on WIN SOURCE:

 [View MAX16060ATE+ on WIN SOURCE](#)

 [Maxim Integrated](#) Information

Optimize Your Supply Chain with WIN SOURCE Solutions

-  Global Sourcing Solution
-  Obsolete Management
-  Cost Control Management
-  Shortage Management
-  Alternative Solution
-  Excess Inventory Management