



**THE DATASHEET OF  
MAX1618MUB+**





# Remote Temperature Sensor with SMBus Serial Interface

MAX1618†

## General Description

The MAX1618 precise digital thermometer reports the temperature of a remote sensor. The remote sensor is a diode-connected transistor—typically a low-cost, easily mounted 2N3904 NPN type—that replaces conventional thermistors or thermocouples. Remote accuracy is  $\pm 3^{\circ}\text{C}$  for multiple transistor manufacturers, with no calibration needed. The MAX1618 can also measure the die temperature of other ICs, such as microprocessors, that contain an on-chip, diode-connected transistor.

The 2-wire serial interface accepts standard System Management Bus (SMBus™) Write Byte, Read Byte, Send Byte, and Receive Byte commands to program the alarm thresholds and to read temperature data. The data format is 7 bits plus sign, with each bit corresponding to  $1^{\circ}\text{C}$ , in two's complement format. Measurements can be done automatically and autonomously, with the 16Hz conversion rate or programmed to operate in a single-shot mode.

The thermostat mode configures the  $\overline{\text{ALERT}}$  output as an interrupt or as a temperature reset that remains active only while the temperature is above the maximum temperature limit or below the minimum temperature limit. The  $\overline{\text{ALERT}}$  output polarity in thermostat mode can be configured for active high or active low. Fan control is implemented using this  $\overline{\text{ALERT}}$  output.

The MAX1618 is available in a small (1.1mm high) 10-pin  $\mu\text{MAX}$  package.

## Applications

Desktop and Notebook Computers	Central Office Telecom Equipment
Smart Battery Packs	Test and Measurement
LAN Servers	Multichip Modules
Industrial Controls	

## Pin Configuration

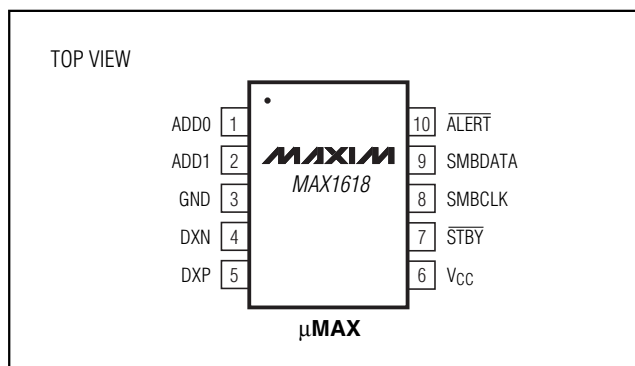

SMBus is a trademark of Intel Corp.  
† Patents Pending



## Features

- ◆ Single Channel: Measures Remote CPU Temperature
- ◆ No Calibration Required
- ◆ SMBus 2-Wire Serial Interface
- ◆ Programmable Under/Overtemperature Alarms
- ◆ Overtemperature Output for Fan Control (Thermostat Mode)
- ◆ Supports SMBus Alert Response Accuracy  
 $\pm 3^{\circ}\text{C}$  ( $+60^{\circ}\text{C}$  to  $+100^{\circ}\text{C}$ )  
 $\pm 5^{\circ}\text{C}$  ( $-55^{\circ}\text{C}$  to  $+120^{\circ}\text{C}$ )
- ◆  $3\mu\text{A}$  (typ) Standby Supply Current
- ◆  $900\mu\text{A}$  (max) Supply Current in Autoconvert Mode
- ◆  $+3\text{V}$  to  $+5.5\text{V}$  Supply Range
- ◆ Small 10-Pin  $\mu\text{MAX}$  Package

## Ordering Information

PART	TEMP. RANGE	PIN-PACKAGE
MAX1618MUB	$-55^{\circ}\text{C}$ to $+125^{\circ}\text{C}$	10 $\mu\text{MAX}$

## Typical Operating Circuit

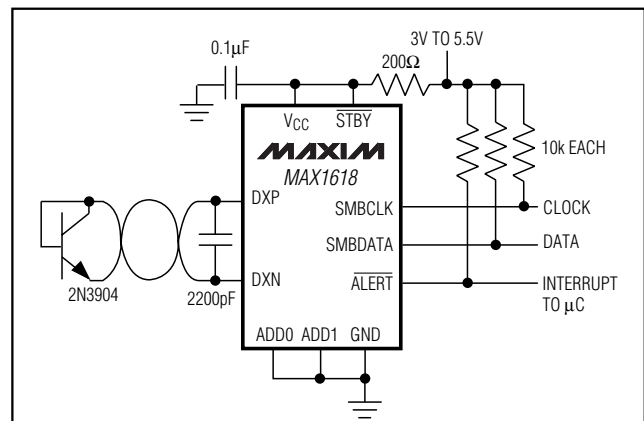

**For pricing, delivery, and ordering information, please contact Maxim/Dallas Direct! at 1-888-629-4642, or visit Maxim's website at [www.maxim-ic.com](http://www.maxim-ic.com).**

# Remote Temperature Sensor with SMBus Serial Interface

## ABSOLUTE MAXIMUM RATINGS

V <sub>CC</sub> to GND .....	-0.3V to +6V	Continuous Power Dissipation (T <sub>A</sub> = +70°C)
DXP, ADD <sub>-</sub> to GND .....	-0.3V to (V <sub>CC</sub> + 0.3V)	μMAX (derate 5.6mW/°C above +70°C) .....
DXN to GND .....	-0.3V to +0.8V	444mW
SMBCLK, SMBDATA, ALERT, STBY to GND .....	-0.3V to +6V	Operating Temperature Range (extended) .....
SMBDATA Current.....	-1mA to 50mA	-55°C to +125°C
DXN Current .....	±1mA	Junction Temperature.....
ESD Protection (all pins, Human Body Model).....	± 2000V	+150°C
		Storage Temperature Range .....
		-65°C to +150°C
		Lead Temperature (soldering, 10s) .....
		+300°C

Stresses beyond those listed under "Absolute Maximum Ratings" may cause permanent damage to the device. These are stress ratings only, and functional operation of the device at these or any other conditions beyond those indicated in the operational sections of the specifications is not implied. Exposure to absolute maximum rating conditions for extended periods may affect device reliability.

## ELECTRICAL CHARACTERISTICS

(V<sub>CC</sub> = +3.3V, configuration byte register = X8h, T<sub>A</sub> = 0°C to +85°C, unless otherwise noted.)

PARAMETER	SYMBOL	CONDITIONS	MIN	TYP	MAX	UNITS	
<b>ADC AND POWER SUPPLY</b>							
Temperature Resolution (Note 1)		Monotonicity guaranteed	8			Bits	
Temperature Error, Remote Diode (Note 2)		T <sub>R</sub> = +60°C to +100°C	-3		3	°C	
		T <sub>R</sub> = +55°C to +125°C	-5		5		
Supply-Voltage Range	V <sub>CC</sub>		3		5.5	V	
Undervoltage Lockout Threshold	UVLO	V <sub>CC</sub> input, disables A/D conversion, rising edge	2.6	2.8	2.95	V	
Undervoltage Lockout Hysteresis				50		mV	
Power-On Reset Threshold		V <sub>CC</sub> , falling edge	1	1.7	2.5	V	
POR Threshold Hysteresis				50		mV	
Standby Supply Current		SMBus static		3	10	μA	
Standby Supply Current		Hardware or software standby, SMBCLK at 10kHz		5		μA	
Average Operating Supply Current		Autoconvert mode, average measured over 4sec, 16 conv/sec		450	900	μA	
Conversion Time	t <sub>CONV</sub>	From stop bit to conversion complete	47	62	78	ms	
Conversion Rate Timing Error		Autoconvert mode	-25		25	%	
Remote-Diode Source Current		DXP forced to DXN + 0.65V, ID = 1 (high)	High level	80	100	120	μA
			Low level	8	10	12	
DXN Source Voltage				0.7		V	
ADDO, ADD1 Bias Current		Momentary upon power-on reset		160		μA	
<b>SMBus INTERFACE</b>							
STBY SMBCLK, SMBDATA Input High Voltage	V <sub>IH</sub>	V <sub>CC</sub> = 3.0V	2.2			V	
STBY, SMBCLK, SMBDATA Input Low Voltage	V <sub>IL</sub>	V <sub>CC</sub> = 3.0V to 5.5V			0.8	V	
STBY, SMBCLK, SMBDATA Input Current		Logic inputs forced to V <sub>CC</sub> or GND	-1		1	μA	
SMBCLK, SMBDATA Output Low Sink Current		SMBCLK, SMBDATA forced to 0.4V	6			mA	

# Remote Temperature Sensor with SMBus Serial Interface

MAX1618

## ELECTRICAL CHARACTERISTICS (continued)

(V<sub>CC</sub> = +3.3V, configuration byte register = X8h, T<sub>A</sub> = 0°C to +85°C, unless otherwise noted.)

PARAMETER	SYMBOL	CONDITIONS	MIN	TYP	MAX	UNITS
ALERT Output Low Sink Current		ALERT forced to 0.4V	6			mA
ALERT Output High Leakage Current		ALERT forced to 5.5V			1	μA
SMBCLK, SMBDATA Input Capacitance				5		pF
SMBus Clock Frequency		(Note 3)	DC		100	kHz
SMBCLK Clock Low Time	t <sub>LOW</sub>	10% to 10% points		4.7		μs
SMBCLK Clock High Time	t <sub>HIGH</sub>	90% to 90% points	4			μs
SMBCLK, SMBDATA Rise Time	t <sub>R</sub>	10% to 90% points			1	μs
SMBCLK, SMBDATA Fall Time	t <sub>F</sub>	90% to 10% points			300	ns
SMBus Start Condition Setup Time			4.7			μs
SMBus Repeated Start Condition Setup Time	t <sub>SU:STA</sub>	90% to 90% points	500			ns
SMBus Start Condition Hold Time	t <sub>HD:STA</sub>	10% of SMBDATA to 90% of SMBCLK	4			μs
SMBus Stop Condition Setup Time	t <sub>SU:STO</sub>	90% of SMBCLK to 10% of SMBDATA	4			μs
SMBus Data Valid to SMBCLK Rising-Edge Time	t <sub>SU:DAT</sub>	90% of SMBDATA to 10% of SMBCLK	250			ns
SMBus Data-Hold Time	t <sub>HD:DAT</sub>	(Note 4)	0			μs
SMBus Bus Free Time	t <sub>BUF</sub>	Between start/stop condition	4.7			μs
SMBCLK Falling Edge to SMBus Data-Valid Time		Master clocking in data			1	μs

## ELECTRICAL CHARACTERISTICS

(V<sub>CC</sub> = +3.3V, configuration byte register = X8h, T<sub>A</sub> = -55°C to +125°C, unless otherwise noted.) (Note 5)

PARAMETER	SYMBOL	CONDITIONS	MIN	TYP	MAX	UNITS
Temperature Resolution (Note 1)		Monotonicity guaranteed	8			Bits
Initial Temperature Error, Remote Diode (Note 2)		T <sub>R</sub> = +60°C to +100°C	-3		3	°C
		T <sub>R</sub> = -55°C to +125°C	-5		5	
Supply-Voltage Range	V <sub>CC</sub>		3		5.5	V
Conversion Time	t <sub>CONV</sub>	From stop bit to conversion complete	47	62	78	ms
Conversion-Rate Timing Error		Autoconvert mode	-25		25	%

# Remote Temperature Sensor with SMBus Serial Interface

## ELECTRICAL CHARACTERISTICS (continued)

(V<sub>CC</sub> = +3.3V, configuration byte register = X8h, T<sub>A</sub> = -55°C to +125°C, unless otherwise noted.) (Note 5)

PARAMETER	CONDITIONS	MIN	TYP	MAX	UNITS
<b>SMBus INTERFACE</b>					
STBY, SMBCLK, SMBDATA Input High Voltage	V <sub>CC</sub> = 3.0V	2.2			V
	V <sub>CC</sub> = 5.5V	2.4			
STBY, SMBCLK, SMBDATA Input Low Voltage	V <sub>CC</sub> = 3.0V to 5.5V			0.8	V
STBY, SMBCLK, SMBDATA Input Current	Logic inputs forced to V <sub>CC</sub> or GND	-2		2	μA
SMBCLK, SMBDATA Output Low Sink Current	SMBCLK, SMBDATA forced to 0.6V	6			mA
ALERT Output Low Sink Current	ALERT forced to 0.4V	1			mA
ALERT Output High Leakage Current	ALERT forced to 5.5V			1	μA

**Note 1:** Guaranteed, but not 100% tested.

**Note 2:** A remote diode is any diode-connected transistor from Table 7. T<sub>R</sub> is the junction temperature of the remote diode. See *Remote Diode Selection* for remote-diode forward voltage requirements. Temperature specification guaranteed for a diode with ideality factor (M<sub>TR</sub> = 1.013). Additional error = (1.013/M - 1) × 273 + Temp where M = Ideality of remote diode used.

**Note 3:** The SMBus logic block is a static design that works with clock frequencies down to DC. While slow operation is possible, it violates the 10kHz minimum clock frequency and SMBus specifications and may monopolize the bus.

**Note 4:** Note that a transition must internally provide at least a hold time to bridge the undefined region (300ns max) of SMBCLK's falling edge.

**Note 5:** Specifications from -55°C to +125°C are guaranteed by design, not production tested.

## Typical Operating Characteristics

(T<sub>A</sub> = +25°C, unless otherwise noted.)

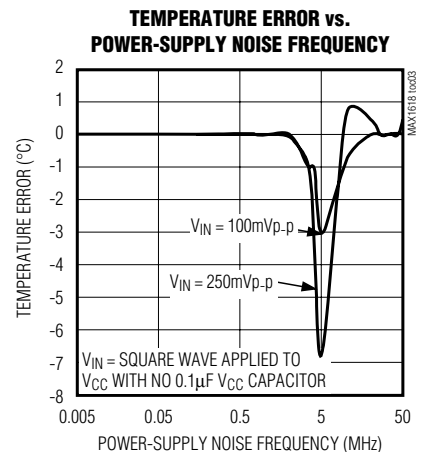
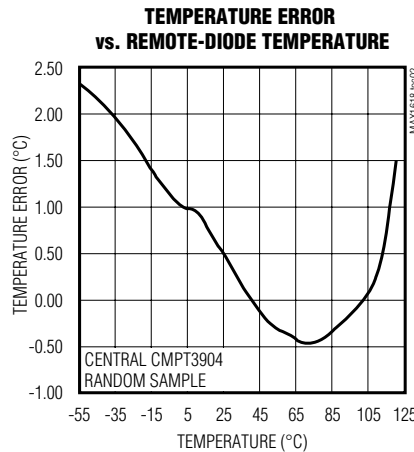
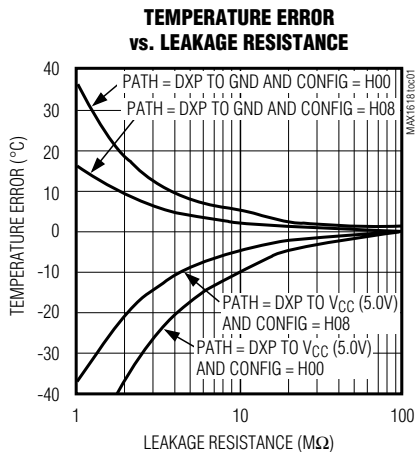

# Remote Temperature Sensor with SMBus Serial Interface

MAX1618

## Typical Operating Characteristics (continued)

( $T_A = +25^\circ\text{C}$ , unless otherwise noted.)

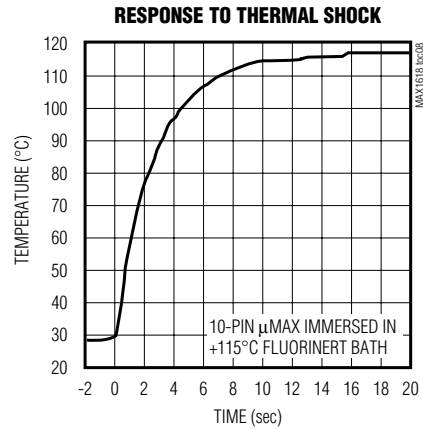
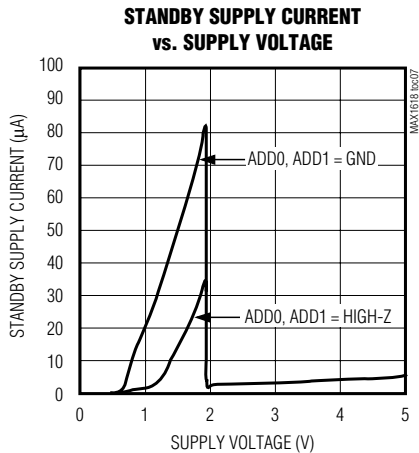
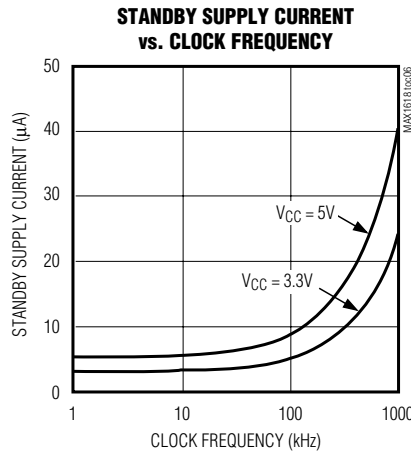
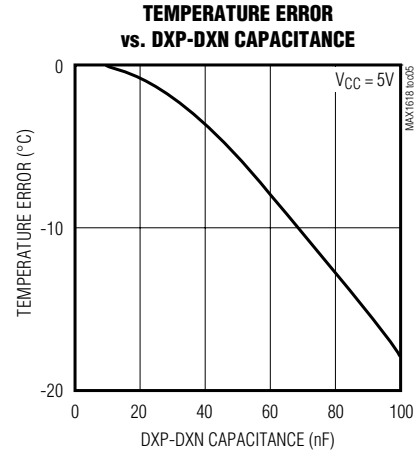
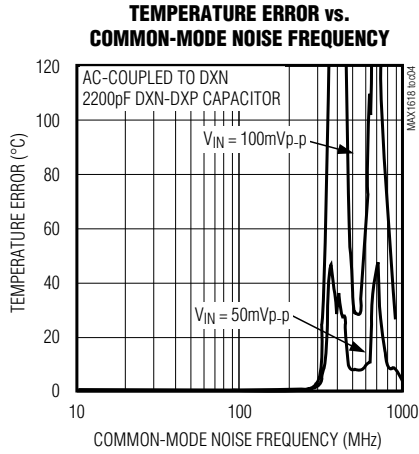

# Remote Temperature Sensor with SMBus Serial Interface

## Pin Description

PIN	NAME	FUNCTION
1	ADD0	SMBus Slave Address Select Input. (See Table 6.) ADD0 and ADD1 are sampled upon power-up. Excess capacitance (>50pF) at the address pins when floating may cause address-recognition problems.
2	ADD1	SMBus Slave Address Select Input. (See Table 6.) ADD0 and ADD1 are sampled upon power-up. Excess capacitance (>50pF) at the address pins when floating may cause address-recognition problems.
3	GND	Ground
4	DXN	Combined Current Sink and A/D Negative Input. DXN is normally biased to a diode voltage above ground.
5	DXP	Combined Current Source and A/D Positive Input. Do not leave DXP floating. Place a 2200pF capacitor between DXP and DXN for noise filtering.
6	V <sub>CC</sub>	Supply Voltage Input. Bypass to GND with a 0.1μF capacitor.
7	$\overline{\text{STBY}}$	Hardware-Standby Input. Temperature and comparison threshold data are retained in standby mode. Low = standby mode. High = operating mode.
8	SMBCLK	SMBus Serial-Clock Input
9	SMBDATA	SMBus Serial-Data Input/Output. Open drain.
10	$\overline{\text{ALERT}}$	SMBus Alert (Interrupt) Output. Open drain.

### Detailed Description

The MAX1618 is a temperature sensor designed to work in conjunction with an external microcontroller (μC) or other intelligence in thermostatic, process-control, or monitoring applications. The μC is typically a power-management or keyboard controller, generating SMBus serial commands by “bit-banging” general-purpose input-output (GPIO) pins or through a dedicated SMBus interface block.

Essentially an 8-bit serial analog-to-digital converter (ADC) with a sophisticated front end, the MAX1618 contains a switched-current source, a multiplexer, an ADC, an SMBus interface, and the associated control logic (Figure 1). Temperature data from the ADC is loaded into a data register, where it is automatically compared with data previously stored in over/under-temperature alarm threshold registers. The alarm threshold registers can be set for hysteretic fan control.

#### ADC and Multiplexer

The averaging ADC integrates over a 30ms period (typ) with excellent noise rejection. The ADC converts at a rate of 16Hz. The multiplexer automatically steers bias

currents through the remote diode, measures the forward voltage, and computes the temperature.

The DXN input is biased at 0.65V above ground by an internal diode to set up the analog-to-digital (A/D) inputs for a differential measurement. The worst-case DXP-DXN differential input voltage range is 0.25V to 0.95V.

Excess resistance in series with the remote diode causes about +1/2°C error/Ω. A 200μV offset voltage at DXP-DXN causes about +1°C error.

#### A/D Conversion Sequence

If a Start command is written (or generated automatically in the free-running autoconvert mode), the result of the measurement is available after the end of conversion. A BUSY status bit in the status byte shows that the device is performing a new conversion. The result of the previous conversion is always available even when the ADC is busy.

# Remote Temperature Sensor with SMBus Serial Interface

**MAX1618**

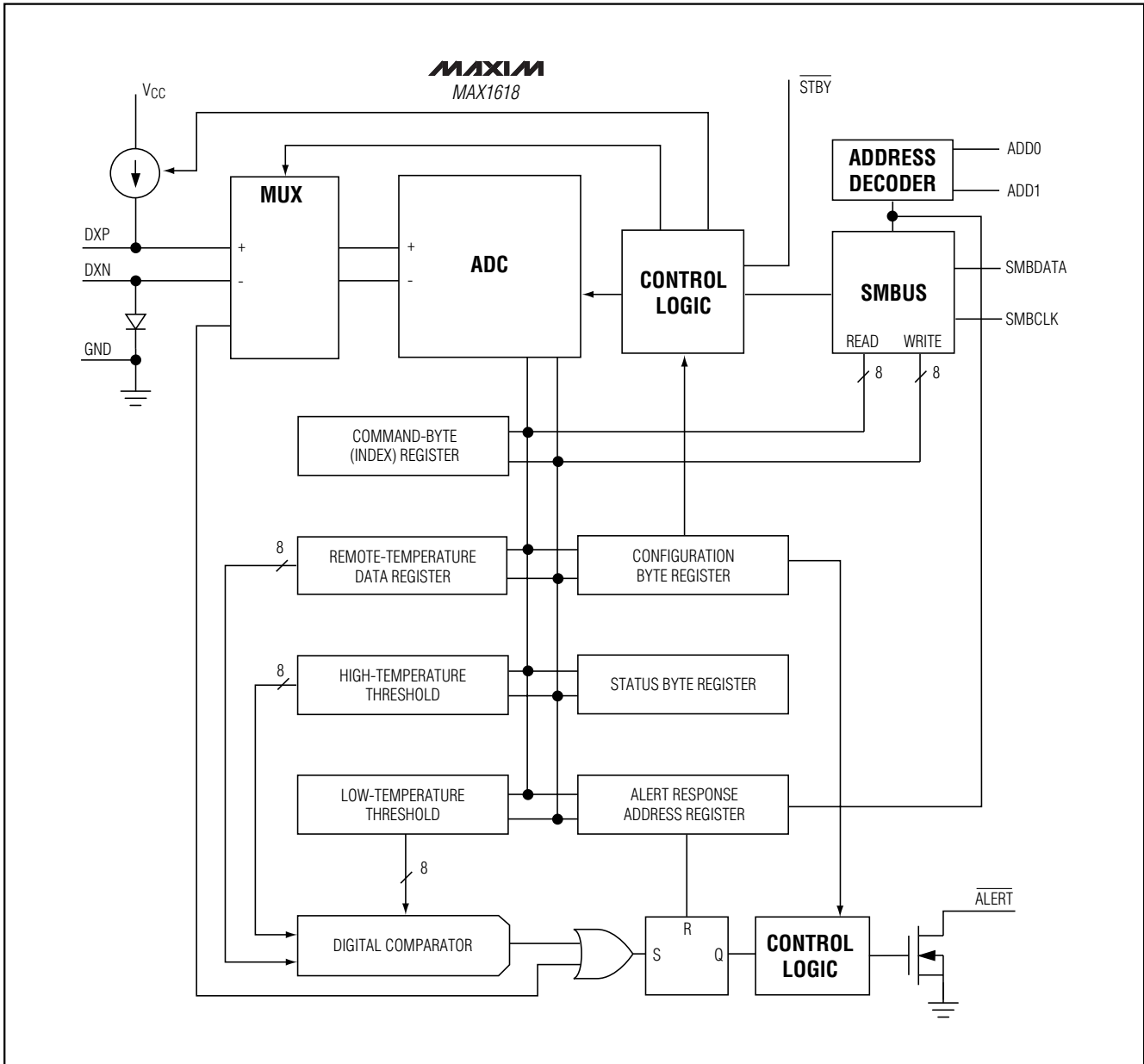

Figure 1. Functional Diagram

# Remote Temperature Sensor with SMBus Serial Interface

## Low-Power Standby Mode

Standby mode disables the ADC and reduces the supply-current drain to 3 $\mu$ A (typ). Enter standby mode by forcing the  $\overline{\text{STBY}}$  pin low or through the RUN/STOP bit in the configuration-byte register. Hardware and software standby modes behave almost identically; all data is retained in memory, and the SMB interface is alive and listening for reads and writes. The only difference is that in hardware-standby mode, the one-shot command does not initiate a conversion.

Standby mode is not a shutdown mode. Activity on the SMBus draws extra supply current (see *Typical Operating Characteristics*). In software-standby mode, the MAX1618 can be forced to perform A/D conversions through the one-shot command, despite the RUN/STOP bit being high.

Enter hardware standby mode by forcing the  $\overline{\text{STBY}}$  pin low. In a notebook computer, this line may be connected to the system SUSTAT# suspend-state signal.

The  $\overline{\text{STBY}}$  pin low state overrides any software conversion command. If a hardware- or software-standby command is received while a conversion is in progress, the conversion cycle is truncated, and the data from that conversion is not latched into either temperature-reading register. The previous data is not changed and remains available.

Supply-current drain during the 62ms conversion period is always about 450 $\mu$ A. Between conversions, the instantaneous supply current is about 25 $\mu$ A due to the current consumed by the conversion-rate timer. In standby mode, supply current drops to about 3 $\mu$ A. With very low supply voltages (under the power-on reset threshold), the supply current is higher due to the address input bias currents. It can be as high as 160 $\mu$ A, depending on ADD0 and ADD1 settings.

## SMBus Digital Interface

From a software perspective, the MAX1618 appears as a set of byte-wide registers that contains temperature data, alarm threshold values, or control bits. Use a standard SMBus 2-wire serial interface to read temperature data and write control bits and alarm threshold data.

The MAX1618 employs four standard SMBus protocols: Write Byte, Read Byte, Send Byte, and Receive Byte (Figure 2). The two shorter protocols (Receive and Send) allow quicker transfers, provided that the correct data register was previously selected by a Write or Read Byte instruction. Use caution with the shorter protocols in multimaster systems, since a second master could overwrite the command byte without informing the first master.

Table 1. Data Format (Two's Complement)

TEMP. (°C)	ROUNDED TEMP. (°C)	DIGITAL OUTPUT DATA BITS		
		SIGN	MSB	LSB
+130.00	+127	0	111	1111
+127.00	+127	0	111	1111
+126.50	+127	0	111	1111
+126.00	+126	0	111	1111
+25.25	+25	0	001	1001
+0.50	+1	0	000	0001
+0.25	0	0	000	0000
0.00	0	0	000	0000
-0.25	0	0	000	0000
-0.50	0	0	000	0000
-0.75	-1	1	111	1111
-1.00	-1	1	111	1111
-25.00	-25	1	110	0111
-25.50	-25	1	110	0111
-54.75	-55	1	100	1001
-55.00	-55	1	100	1001
-65.00	-65	1	011	1111
-70.00	-65	1	011	1111

The temperature data format is 7 bits plus sign in two's complement form for each channel, with each data bit representing +1°C (Table 1), transmitted MSB first. Measurements are offset by +1/2°C to minimize internal rounding errors; for example, +99.6°C is reported as +100°C.

## Alarm Threshold Registers

Two registers, a high-temperature ( $T_{\text{HIGH}}$ ) and a low-temperature ( $T_{\text{LOW}}$ ) register, store alarm threshold data. If a measured temperature equals or exceeds the corresponding alarm threshold value, an  $\overline{\text{ALERT}}$  interrupt is asserted.

The power-on reset (POR) state of the  $T_{\text{HIGH}}$  register is full scale (0111 1111 or +127°C). The POR state of the  $T_{\text{LOW}}$  register is 1100 1001 or -55°C.

## Thermostat Mode

Thermostat mode changes the function of the  $\overline{\text{ALERT}}$  output from a latched interrupt-type output to a self-clearing thermostat for fan control. This output simply responds to the current temperature (Figure 3). If the current temperature is above  $T_{\text{HIGH}}$ ,  $\overline{\text{ALERT}}$  activates

# Remote Temperature Sensor with SMBus Serial Interface

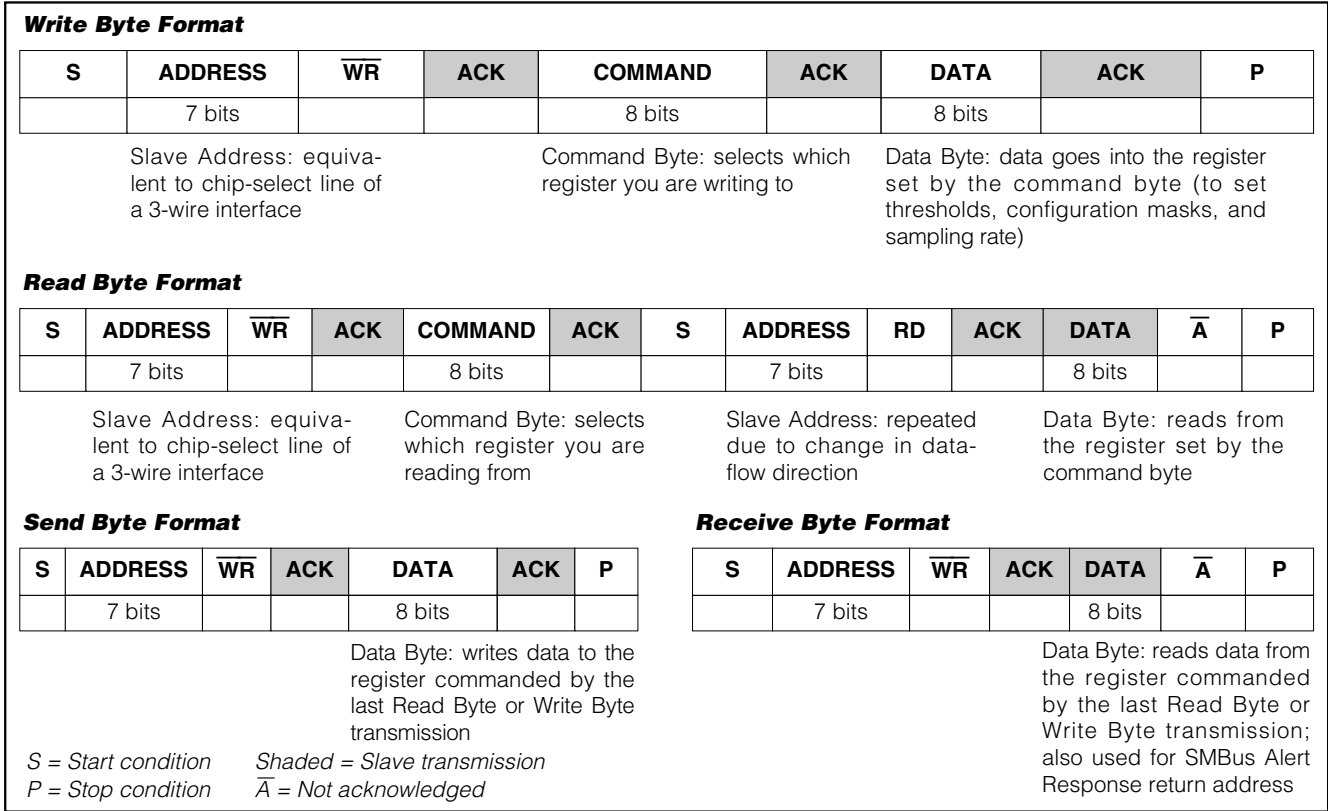

Figure 2. SMBus Protocols

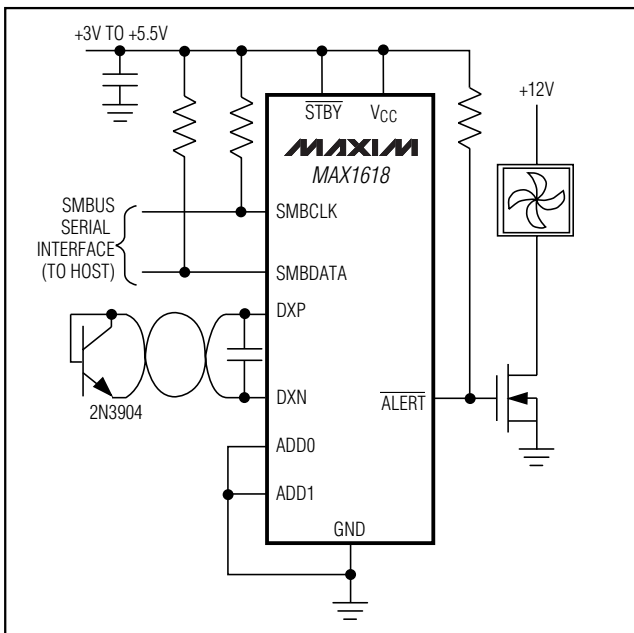

Figure 3. Fan Control Application

and does not go inactive until the temperature drops below  $T_{LOW}$ .

Enable thermostat mode through the configuration register (Table 4), with one bit to enable the feature and another bit to set the output polarity (active high or active low). The  $\overline{ALERT}$  thermostat comparison is made after each conversion, or at the end of any SMBus transaction. For example, if the limit is changed while the device is in standby mode, the  $\overline{ALERT}$  output responds correctly according to the last valid A/D result. Upon entering thermostat mode, the  $\overline{ALERT}$  output is reset so that if the temperature is in the hysteresis band  $\overline{ALERT}$  initially goes inactive. The power-on reset (POR) state disables thermostat mode.

### Diode Fault Alarm

A continuity fault detector at DXP detects whether the remote diode has an open-circuit condition, short-circuit to GND, or short-circuit DXP-to-DXN condition. At the beginning of each conversion, the diode fault is checked, and the status byte is updated. This fault detector is a simple voltage detector; if DXP rises

# Remote Temperature Sensor with SMBus Serial Interface

above  $V_{CC} - 1V$  (typ) or below  $V_{DXN} + 50mV$  (typ), a fault is detected and  $\overline{ALERT}$  is asserted. ADC reads  $+127^{\circ}C$ . Also, if the ADC has an extremely low differential input voltage, the diode is assumed to be shorted and a fault is detected. Note that the diode fault is not checked until a conversion is initiated, so immediately after power-on reset, the status byte indicates no fault is present even if the diode path is broken.

## **$\overline{ALERT}$ Interrupts**

Normally, the  $\overline{ALERT}$  interrupt output signal is latched and can be cleared only by reading the Alert Response address. Interrupts are generated in response to  $T_{HIGH}$  and  $T_{LOW}$  comparisons and when the remote diode is faulted. The interrupt does not halt automatic conversions; new temperature data continues to be available over the SMBus interface after  $\overline{ALERT}$  is asserted. The interrupt output pin is open-drain so the devices can share a common interrupt line.

The interface responds to the SMBus Alert Response address, an interrupt pointer return-address feature (see *Alert Response Address* section). Before taking corrective action, always check to ensure that an interrupt is valid by reading the current temperature.

The alert activates only once per crossing of a given temperature threshold to prevent any re-entrant interrupts. To enable a new interrupt, rewrite the value of the violated temperature threshold.

## **Alert Response Address**

The SMBus Alert Response interrupt pointer provides quick fault identification for simple slave devices that lack the complex, expensive logic needed to be a bus master. Upon receiving an  $\overline{ALERT}$  interrupt signal, the host master can broadcast a Receive Byte transmission to the Alert Response slave address (0001100). Any slave device that generated an interrupt then attempts to identify itself by putting its own address on the bus (Table 2).

The Alert Response can activate several different slave devices simultaneously, similar to the I<sup>2</sup>C General Call. If more than one slave attempts to respond, bus arbitration rules apply, and the device with the lower address code wins. The losing device does not generate an acknowledgement and continues to hold the  $\overline{ALERT}$  line low until serviced (implies that the host interrupt input is level sensitive). Successful reading of the alert response address clears the interrupt latch.

## **Command Byte Functions**

The 8-bit command byte register (Table 3) is the master index that points to the other registers within the MAX1618. The register's POR state is 0000 0001, so a

*I<sup>2</sup>C is a trademark of Philips Corp.*

**Table 2. Read Format for Alert Response Address (0001 100)**

BIT	NAME	FUNCTION
7 (MSB)	ADD7	Provide the current MAX1618 slave address that was latched at POR (Table 6)
6	ADD6	
5	ADD5	
4	ADD4	
3	ADD3	
2	ADD2	
1	ADD1	
0 (LSB)	ADD0	Logic 1

Receive Byte transmission (a protocol that lacks the command byte) that occurs immediately after POR returns the current remote temperature data.

The one-shot command immediately forces a new conversion cycle to begin. A new conversion begins in software standby mode (RUN/STOP bit = high). The device returns to standby mode after the conversion. If a conversion is in progress when a one-shot command is received, the command is ignored. If a one-shot command is received in autoconvert mode (RUN/STOP bit = low) between conversions, a new conversion begins; the conversion rate timer is reset, and the next automatic conversion takes place after a full delay elapses.

## **Configuration Byte Functions**

The configuration byte register (Table 4) is used to mask (disable) interrupts, to put the device in software-standby or thermostat mode, change the polarity of the alert output (thermostat mode only), and to change the diode bias current. The lower three bits are internally driven low (000), making them "don't care" bits. Write zeros to these bits. The serial interface can read back this register's contents.

## **Status Byte Functions**

The status byte register (Table 5) indicates which (if any) temperature thresholds have been exceeded. This byte also indicates whether the ADC is converting and whether there is a fault in the remote diode DXP-DXN path. After POR, the normal state of all the flag bits is zero, assuming none of the alarm conditions is present. The status byte is cleared by any successful read of the status byte. Note that the  $\overline{ALERT}$  interrupt latch is not automatically cleared when the status flag bit is cleared.

# Remote Temperature Sensor with SMBus Serial Interface

MAX1618

**Table 3. Command-Byte Bit Assignments**

REGISTER	COMMAND	POR STATE	FUNCTION
RFU	00h	N/A	Reserved for future use
RRTE	01h	0000 0000*	Read remote temperature; returns latest temperature
RSL	02h	N/A	Read status byte (flags, busy signal)
RCL	03h	0000 1000	Read configuration byte
RCRA	04h	0000 0111	Read conversion rate byte (not supported by MAX1618)
RFU	05h	N/A	Reserved for future use
RFU	06h	N/A	Reserved for future use
RRHI	07h	0111 1111	Read remote T <sub>HIGH</sub> limit
RRLS	08h	1100 1001	Read remote T <sub>LOW</sub> limit
WCA	09h	N/A	Write configuration byte
WCRW	0Ah	N/A	Write conversion rate byte (not supported by MAX1618)
RFU	0Bh	N/A	Reserved for future use
RFU	0Ch	N/A	Reserved for future use
WRHA	0Dh	N/A	Write remote T <sub>HIGH</sub> limit
WRLN	0Eh	N/A	Write remote T <sub>LOW</sub> limit
OSHT	0Fh	N/A	One-shot command
MFGID	FEh	01001101	Read manufacturer ID code
DEVID	FFh	00000010	Read device ID code

\*If the device is in hardware-standby mode at POR, the temperature register reads 0°C.

**Table 4. Configuration-Byte Bit Assignments**

BIT	NAME	POR STATE	FUNCTION
7 (MSB)	MASK	0	Masks all $\overline{\text{ALERT}}$ interrupts when high.
6	RUN/STOP	0	Standby mode control bit. If high, the device immediately stops converting and enters standby mode. If low, the device converts in either one-shot or timer mode.
5	POL	0	$\overline{\text{ALERT}}$ pin polarity control in thermostat mode. 0 = active low 1 = active high
4	THERM	0	Enables thermostat mode when high.
3	ID	1	Enables diode bias current. 0 (Logic Low) = 5 $\mu$ A to 50 $\mu$ A (typ) 1 (Logic High) = 10 $\mu$ A to 100 $\mu$ A (typ)
2 to 0	RFU	0	Reserved for future use.

**Table 5. Status-Byte Bit Assignments**

BIT	NAME	FUNCTION
7 (MSB)	BUSY	A high indicates that the ADC is busy converting.
6, 5	RFU	Reserved for future use (returns 0).
4	RHIGH*	A high indicates that the remote high-temperature alarm has activated. In thermostat mode, this bit is always in the same state as the $\overline{\text{ALERT}}$ output.
3	RLOW*	A high indicates that the remote low-temperature alarm has activated. In thermostat mode, this bit is always zero.
2	DIODE	A high indicates a remote-diode fault (open-circuit, shorted diode, or DXP short to GND).
1, 0 (LSB)	RFU	Reserved for future use (returns 0).

\*In  $\overline{\text{ALERT}}$  mode, the HIGH and LOW temperature alarm flags stay high until cleared by POR or until the status byte register is read.

# Remote Temperature Sensor with SMBus Serial Interface

**Table 6. Slave Address Decoding  
(ADD0 and ADD1)**

ADD0	ADD1	ADDRESS
GND	GND	0011 000
GND	High-Z	0011 001
GND	V <sub>CC</sub>	0011 010
High-Z	GND	0101 001
High-Z	High-Z	0101 010
High-Z	V <sub>CC</sub>	0101 011
V <sub>CC</sub>	GND	1001 100
V <sub>CC</sub>	High-Z	1001 101
V <sub>CC</sub>	V <sub>CC</sub>	1001 110

**Note:** High-Z means the pin is left unconnected and floating.

### Slave Addresses

The device address can be set to one of nine different values by pin-strapping ADD0 and ADD1 so more than one MAX1618 can reside on the same bus without address conflicts (Table 6).

The address pin states are checked at POR only, and the address data stays latched to reduce quiescent supply current due to the bias current needed for high-impedance (high-Z) state detection.

The MAX1618 also responds to the SMBus Alert Response slave address (see the *Alert Response Address* section).

### POR and UVLO

The MAX1618 has a volatile memory. To prevent ambiguous power-supply conditions from corrupting the data in the memory and causing erratic behavior, a POR voltage detector monitors V<sub>CC</sub> and clears the memory if V<sub>CC</sub> falls below 1.7V (typical, see the *Electrical Characteristics* table). When power is first applied and V<sub>CC</sub> rises above 1.75V (typ), the logic blocks begin operating, although reads and writes at V<sub>CC</sub> levels below 3V are not recommended. A second V<sub>CC</sub> comparator, the ADC UVLO comparator, prevents the ADC from converting until there is sufficient headroom (V<sub>CC</sub> = 2.8V typ).

### Power-Up Defaults:

- Interrupt latch is cleared.
- Address select pins are sampled.
- Command byte is set to 01h to facilitate quick remote Receive Byte queries.
- T<sub>HIGH</sub> and T<sub>LOW</sub> registers are set to max and min limits, respectively.
- Device is in normal mode.  $\overline{\text{ALERT}}$  acts as a latched interrupt output.)

*Pentium II* is a registered trademark of Intel Corp.

**Table 7. SOT23 Type Remote-Sensor  
Transistor Manufacturers**

MANUFACTURER	MODEL NUMBER
Central Semiconductor (USA)	CMPT3904
Fairchild Semiconductor (USA)	MMBT3904
Motorola (USA)	MMBT3904
Rohm Semiconductor (Japan)	SST3904
Siemens (Germany)	SMBT3904
Zetex (England)	FMMT3904CT-ND

**Note:** Transistors must be diode-connected (short the base to the collector).

## Applications Information

### Remote Diode Selection

Temperature accuracy depends on having a good-quality, diode-connected, small-signal transistor. Accuracy has been experimentally verified for all of the devices listed in Table 7. The MAX1618 can also directly measure the die temperature of CPUs and other integrated circuits with on-board temperature sensing diodes, such as the Intel Pentium II®.

The transistor must be a small-signal type with a relatively high forward voltage. This ensures that the input voltage is within the A/D input voltage range. The forward voltage must be greater than 0.25V at 10μA at the highest expected temperature. The forward voltage must be less than 0.95V at 100μA at the lowest expected temperature. The base resistance has to be less than 100Ω. Tight specification of forward-current gain (+50 to +150, for example) indicates that the manufacturer has good process controls and that the devices have consistent V<sub>BE</sub> characteristics. Do not use power transistors.

### ADC Noise Filtering

The integrating ADC has inherently good noise rejection, especially of low-frequency signals such as 60Hz/120Hz power-supply hum. Micropower operation places constraints on high-frequency noise rejection. Lay out the PCB carefully with proper external noise filtering for high-accuracy remote measurements in electrically noisy environments.

Filter high-frequency electromagnetic interference (EMI) at DXP and DXN with an external 2200pF capacitor connected between the two inputs. This capacitor can be increased to about 3300pF (max), including cable capacitance. A capacitance higher than 3300pF

# Remote Temperature Sensor with SMBus Serial Interface

MAX1618

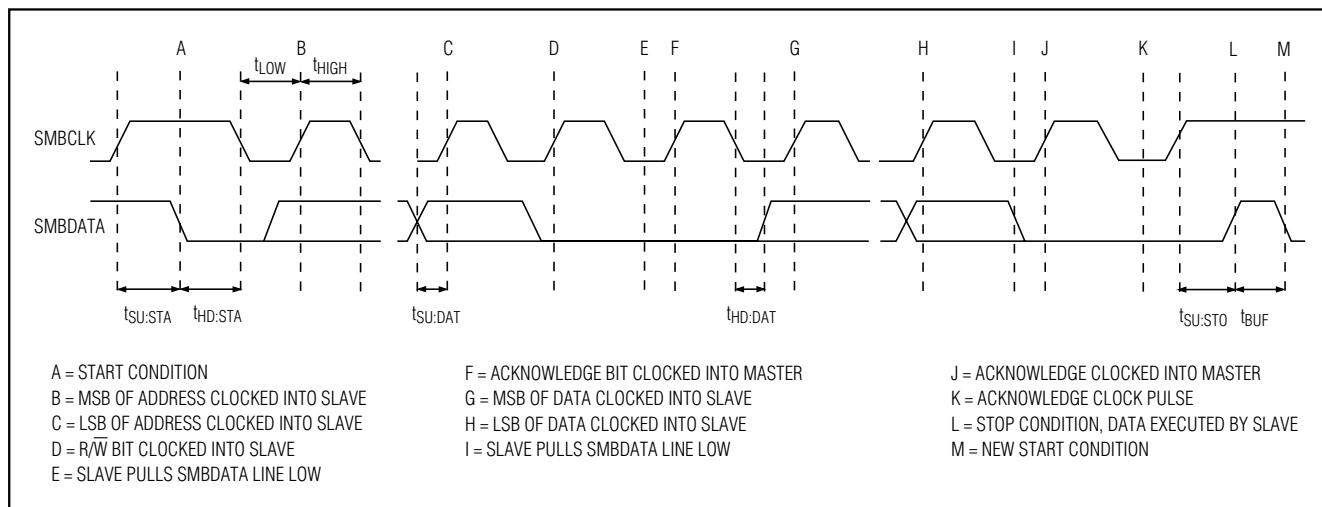

Figure 4. SMBus Write Timing Diagram

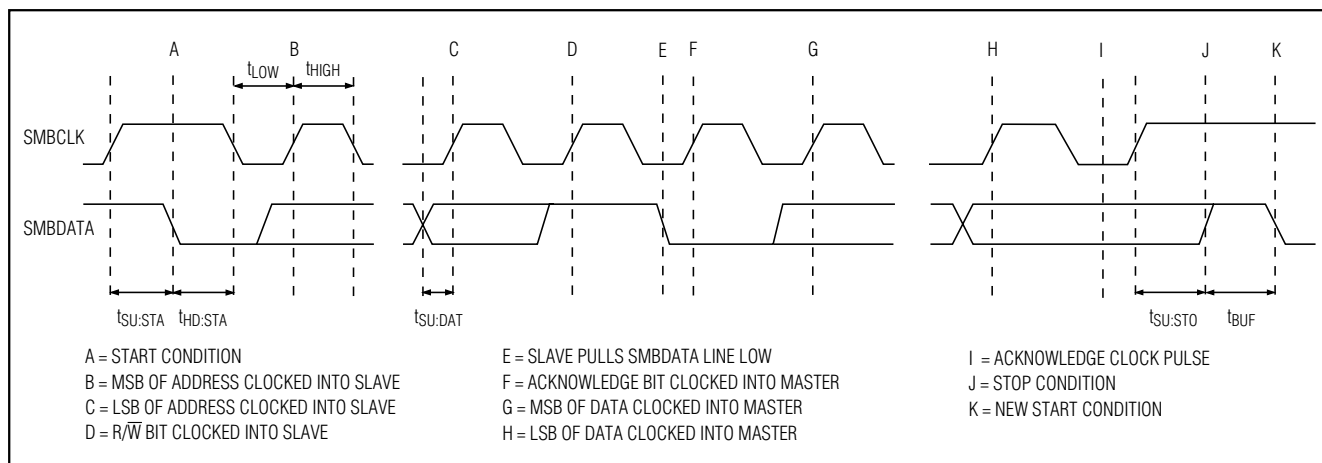

Figure 5. SMBus Read Timing Diagram

introduces errors due to the rise time of the switched-current source.

### PC Board Layout

- 1) Place the MAX1618 as close as practical to the remote diode. In a noisy environment, such as a computer motherboard, this distance can be 4 inches to 8 inches (typ) or more, as long as the worst noise sources (such as CRTs, clock generators, memory buses, and ISA/PCI buses) are avoided.
- 2) Do not route the DXP–DXN lines next to the deflection coils of a CRT. Also, do not route the traces across a fast memory bus, which can easily introduce +30°C error, even with good filtering. Otherwise, most noise sources are fairly benign.
- 3) Route the DXP and DXN traces parallel and close to each other, away from any high-voltage traces such as +12V<sub>DC</sub>. Avoid leakage currents from PC board contamination. A 20MΩ leakage path from DXP to ground causes approximately +1°C error.
- 4) Connect guard traces to GND on either side of the DXP–DXN traces (Figure 5). With guard traces in place, routing near high-voltage traces is no longer an issue.
- 5) Route as few vias and crossunders as possible to minimize copper/solder thermocouple effects.

# Remote Temperature Sensor with SMBus Serial Interface

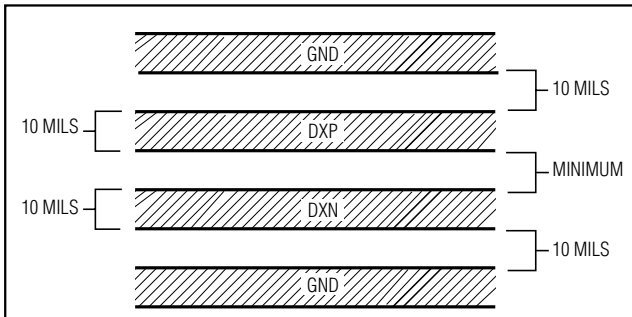

Figure 6. Recommended DXP/DXN PC Traces

- 6) When introducing a thermocouple, make sure that both the DXP and the DXN paths have matching thermocouples. In general, PC board-induced thermocouples are not a serious problem. A copper-solder thermocouple exhibits  $3\mu\text{V}/^\circ\text{C}$ , and it takes approximately  $200\mu\text{V}$  of voltage error at DXP-DXN to cause a  $+1^\circ\text{C}$  measurement error, so most parasitic thermocouple errors are swamped out.
- 7) Use wide traces. Narrow traces are more inductive and tend to pick up radiated noise. The 10mil widths and spacings recommended in Figure 5 are not absolutely necessary (as they offer only a minor improvement in leakage and noise), but try to use them where practical.
- 8) Note that copper cannot be used as an EMI shield. Use only ferrous materials such as steel. Placing a copper ground plane between the DXP-DXN traces and traces carrying high-frequency noise signals does not help reduce EMI.

### Twisted Pair and Shielded Cables

For remote-sensor distances longer than 8 inches, or in particularly noisy environments, a twisted pair is recommended. Its practical length is 6 feet to 12 feet (typ) before noise becomes a problem, as tested in a noisy electronics laboratory. For longer distances, the best solution is a shielded twisted pair like that used for audio microphones. For example, Belden #8451 works well for distances up to 100 feet in a noisy environment. Connect the twisted pair to DXP and DXN and the shield to GND, and leave the shield's remote end unterminated.

Excess capacitance at DX\_ limits practical remote-sensor distances (see *Typical Operating Characteristics*). For very long cable runs, the cable's parasitic capacitance often provides noise filtering, so the recommended 2200pF capacitor can often be removed or reduced in value.

Cable resistance also affects remote-sensor accuracy. A  $1\Omega$  series resistance introduces about  $+1/2^\circ\text{C}$  error.

### Programming Example: Clock-Throttling Control for CPUs

Listing 1 gives an untested example of pseudocode for proportional temperature control of Intel mobile CPUs through a power-management microcontroller. This program consists of two main parts: an initialization routine and an interrupt handler. The initialization routine checks for SMBus communications problems and sets up the MAX1618 configuration. The interrupt handler responds to  $\overline{\text{ALERT}}$  signals by reading the current temperature and setting a CPU clock duty factor proportional to that temperature. The relationship between clock duty and temperature is fixed in a look-up table contained in the microcontroller code.

**Note:** Thermal management decisions should be made based on the latest external temperature obtained from the MAX1618 rather than the value of the Status Byte. The MAX1618 responds very quickly to changes in its environment due to its sensitivity and its small thermal mass. High and low alarm conditions can exist at the same time in the Status Byte, because the MAX1618 is correctly reporting environmental changes around it.

## Chip Information

TRANSISTOR COUNT: 9911

# Remote Temperature Sensor with SMBus Serial Interface

MAX1618

## Listing 1. Pseudocode Example

```
/* Beginning of the header file which sets the constants */

int    NumStates    = 10;
int    RRTE        = 1; /* 0x01, command for reading remote temp
register */
int    WCA         = 9; /* 0x09, command for writing configuration
register */
int    RSL         = 2; /* 0x02, command for reading status register */
int    WRHA        = 13; /* 0x0D, command for writing remote THIGH limit
register */
int    WRLN        = 14; /* 0x0E, command for writing remote TLOW limit
register */
int    NoError     = 0;
int    Nobody      = 0;
int    MAX1618Addr = 84; /* 0x54, default address for MAX1618,
ADD0,ADD1=open */
int    InitConfig  = 8; /* 0x08, configure MAX1618 to MASK=0 and
RUN/STOP=0 */
int    HighAdder   = 2; /* 2oC offset for calculating THIGH limit */
int    LowSubtractor = 4; /* 4oC offset for calculating TLOW limit
*/
int    CollisionMask = 1; /* 0x01, mask for status bit that
indicates collision */
int    DiodeFaultMask = 4; /* 0x04, mask for the OPEN diode fault
status bit */
int    TempChangeMask = 24; /* 0x18, mask for RHIGH and RLOW status
bits */

array State[0..NumStates] of int;

State[0] = -65 oC /* At or above this temperature CPU duty cycle is
100% */
State[1] = 72 oC /* At or above this temperature CPU duty cycle is
87.5% */
State[2] = 74 oC /* At or above this temperature CPU duty cycle is 75%
*/
State[3] = 76 oC /* At or above this temperature CPU duty cycle is
62.5% */
State[4] = 78 oC /* At or above this temperature CPU duty cycle is 50%
*/
State[5] = 80 oC /* At or above this temperature CPU duty cycle is
37.5% */
State[6] = 82 oC /* At or above this temperature CPU duty cycle is 25%
*/
State[7] = 84 oC /* At or above this temperature CPU duty cycle is
12.5% */
State[8] = 86 oC /* At or above this temperature CPU duty cycle is
0.0% */
State[9] = 88 oC /* At or above this temperature SHUT SYSTEM OFF! */
State[10] = 127 oC /* Extra array location so looping is easier */

/* End of the header file */
```

# Remote Temperature Sensor with SMBus Serial Interface

## Listing 1. Pseudocode Example (continued)

```

int Initialization()
{
    int ErrorCode      = NoError;
    /* Test the SMBus communications path to the MAX1618 by writing the
    configuration and initial temperature limits; if SMBus communication
    was unsuccessful, power the system down. Note that the MAX1618Write
    procedure takes three parameters: the command code of the register to
    be written, the data to write, and a pointer to the the error code
    variable. If the error code variable does not equal NoError before the
    execution of MAX1618Write, MAX1618Write does nothing. If the SMBus
    communication fails in MAX1618Write, the error code variable is set to
    the type of error (for example a NACK, i.e. MAX1618 did not
    acknowledge). This code assumes that the BIOS is already in thermal
    state 0 (not throttling, i.e. full CPU clock rate) when the
    initialization routine is executed. */

    MAX1618Write(WCA, InitConfig, &ErrorCode);          /* MASK=0 and
    RUN/STOP=0 */
    MAX1618Write(WRLN, LowestTemp, &ErrorCode);        /* TLOW = -65oC
    */
    MAX1618Write(WRHA, State[0] + HighAdder, &ErrorCode) /* THIGH =
    72oC */
    if (ErrorCode != NoError) then {
        /* Power off the system */
    } /* End of if (ErrorCode ... */
    return (ErrorCode);
} /* End of Initialization routine */

```

# Remote Temperature Sensor with SMBus Serial Interface

MAX1618

Listing 1. Pseudocode Example (continued)

```
int ALERT_IntHandler()
{
    int ErrorCode      = NoError;
    int WhoDunnit      = Nobody;
    int FoundState     = 0;
    int StatusInfo     = 0;
    int TempHigh;
    int TempLow;
    /* This interrupt handler verifies that the MAX1618 is the source of
    the interrupt (and also clears the interrupt) via the SMBus Alert
    Response address; checks the status byte to ensure that a temperature
    change did indeed cause the interrupt; reads the remote temperature;
    programs a corresponding clock-throttling duty cycle, and sets up new
    Thigh and Tlow limits. */

    ReadAlertResponse(&WhoDunnit, &ErrorCode);
    if (WhoDunnit == MAX1618Addr) then {

        MAX1618Read(RSL, &StatusInfo, &ErrorCode);

        if (((StatusInfo & CollisionMask) != 0) and (ErrorCode ==
NoError)) then
            MAX1618Read(RSL, &StatusInfo, &ErrorCode);

            if (StatusInfo & DiodeFaultMask) != 0) then {

                /* Shut down system because thermal diode doesn't
work */

            }
            else if ((StatusInfo & TempChangeMask) != 0) then {

                MAX1618Read(RRTE, &TempRead, &ErrorCode);
                while ((TempRead >= State[FoundState + 1]) and
                    (FoundState < (NumStates - 1))) do
FoundState++;
                if (FoundState == (NumStates - 1)) then {
                    /* Ahhhhh!!! SHUT SYSTEM OFF!!!! */
                }
                else {
                    /* adjust clock duty cycle */
                    TempHigh = TempRead + HighAdder;
                    TempLow = TempRead - LowSubtractor;
                    MAX1618Write(WRHA, TempHigh, &Error);
                    MAX1618Write(WRLN, TempLow, &Error);
                } /* End of if (FoundState ... */

            } /* End of if ((StatusInfo .. else if ... */

            /* Handle local temp status bits if set */

        }
    }
    else {
        /* Handle cases for other interrupt sources */
    } /* End of if (WhoDunnit ... */

    return(ErrorCode);
}
```

# Remote Temperature Sensor with SMBus Serial Interface

## Package Information

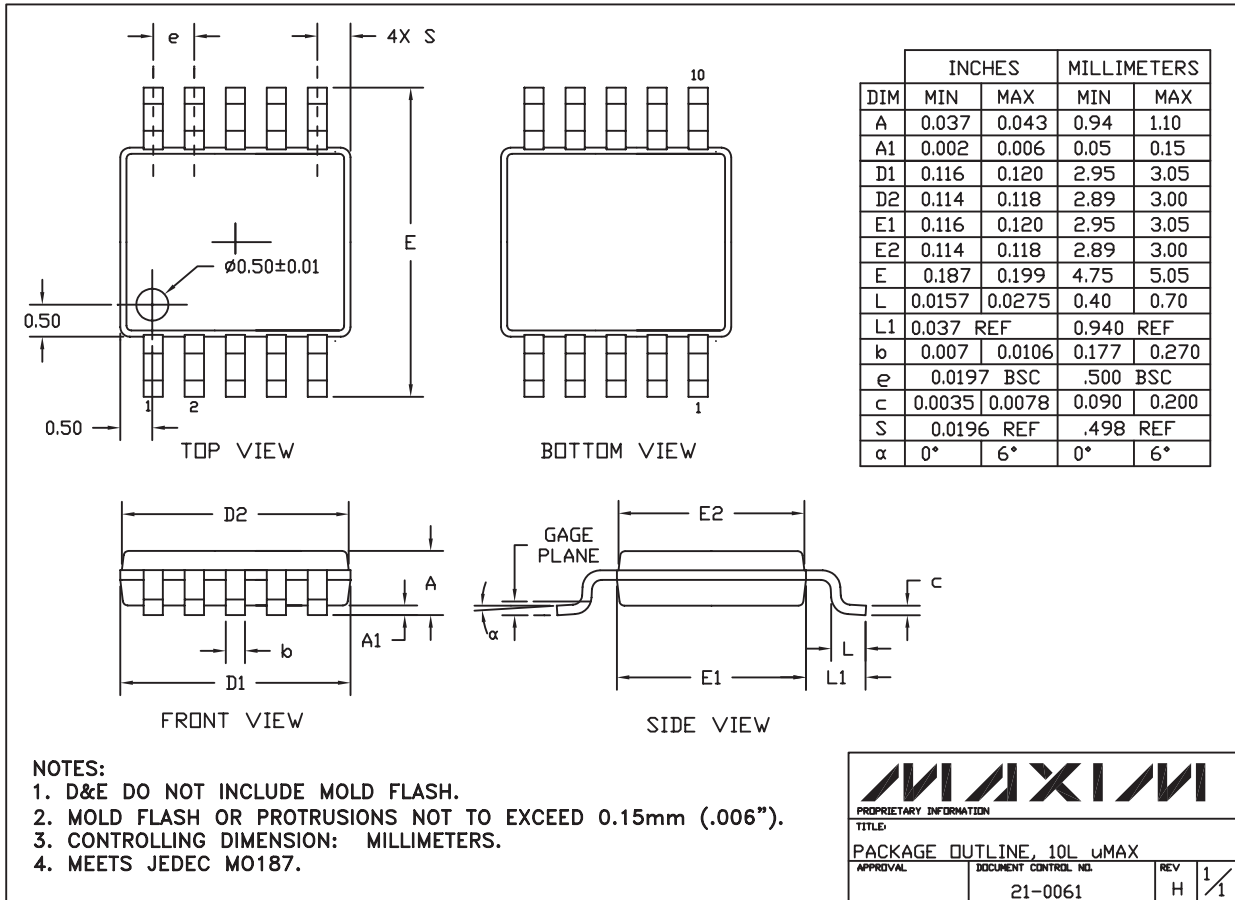

10LUMAX.EPS

Maxim cannot assume responsibility for use of any circuitry other than circuitry entirely embodied in a Maxim product. No circuit patent licenses are implied. Maxim reserves the right to change the circuitry and specifications without notice at any time.

18 \_\_\_\_\_ **Maxim Integrated Products, 120 San Gabriel Drive, Sunnyvale, CA 94086 408-737-7600**

## Looking for pricing, stock, or lifecycle information?

Click below to explore more details on WIN SOURCE:

- ⊖ [View MAX1618MUB+](#) on WIN SOURCE
- ⊖ [Maxim Integrated](#) Information

## Optimize Your Supply Chain with WIN SOURCE Solutions

- ✓ Global Sourcing Solution
- ✓ Obsolete Management
- ✓ Cost Control Management
- ✓ Shortage Management
- ✓ Alternative Solution
- ✓ Excess Inventory Management