



# THE DATASHEET OF MAX1666VEEP



# MAXIM

## Advanced Lithium-Ion Battery-Pack Protector

MAX1666A/S/V/X

### General Description

The MAX1666 provides complete protection against over-voltage, undervoltage, overcharge current, overdischarge current, and cell mismatch for 2-cell to 4-cell lithium-ion (Li+) battery packs. The voltage of each cell in the battery pack is checked and compared to the programmable threshold and to the other cells in the pack.

The MAX1666 protects the battery pack in an overcurrent condition by disconnecting the pack from the load at a programmable limit. On-chip power MOSFET drivers control external P-channel MOSFETs to disconnect the cells from external terminals when faults occur.

The MAX1666 employs a unique timing scheme that allows three modes of operation for optimal performance and battery power conservation. The MAX1666 can operate in a stand-alone configuration or in conjunction with a microcontroller. It is available in four versions: the S version monitors two Li+ cells, the A and V versions monitor three cells, and the X version monitors four cells. When the charge path is disabled by the charge control pin, the MAX1666A reduces current consumption compared to the MAX1666S/V/X.

### Features

- ◆ **Overvoltage Protection**  
Programmable Limits from +4.0V to +4.4V  
Accurate to ±0.5%
- ◆ **Undervoltage Protection**  
Programmable Limits from +2.0V to +3.0V  
Accurate to ±2.5%
- ◆ **Cell Mismatch Protection**  
Programmable Limits from 0 to 500mV  
Accurate to ±10%
- ◆ **Overcharge Current Protection**
- ◆ **Overdischarge Current Protection**
- ◆ **Low 30µA (typ) Operating Supply Current**
- ◆ **Low 1µA (max) Standby Current**
- ◆ **+28V (max) Input Voltage**
- ◆ **Available in Small 16-Pin QSOP (MAX1666S) and 20-Pin QSOP (MAX1666A/V/X) Packages**

### Applications

2/3/4-Cell Lithium-Ion Battery Pack

### Selector Guide

PART	NUMBER OF Li+ CELLS
MAX1666S	2
MAX1666A/V	3
MAX1666X	4

Typical Operating Circuits appear at end of data sheet.

### Ordering Information

PART	TEMP RANGE	PIN-PACKAGE
MAX1666SEEE	-40°C to +85°C	16 QSOP
MAX1666AEEP	-40°C to +85°C	20 QSOP
MAX1666VEEP	-40°C to +85°C	20 QSOP
MAX1666XEEP	-40°C to +85°C	20 QSOP

### Pin Configurations

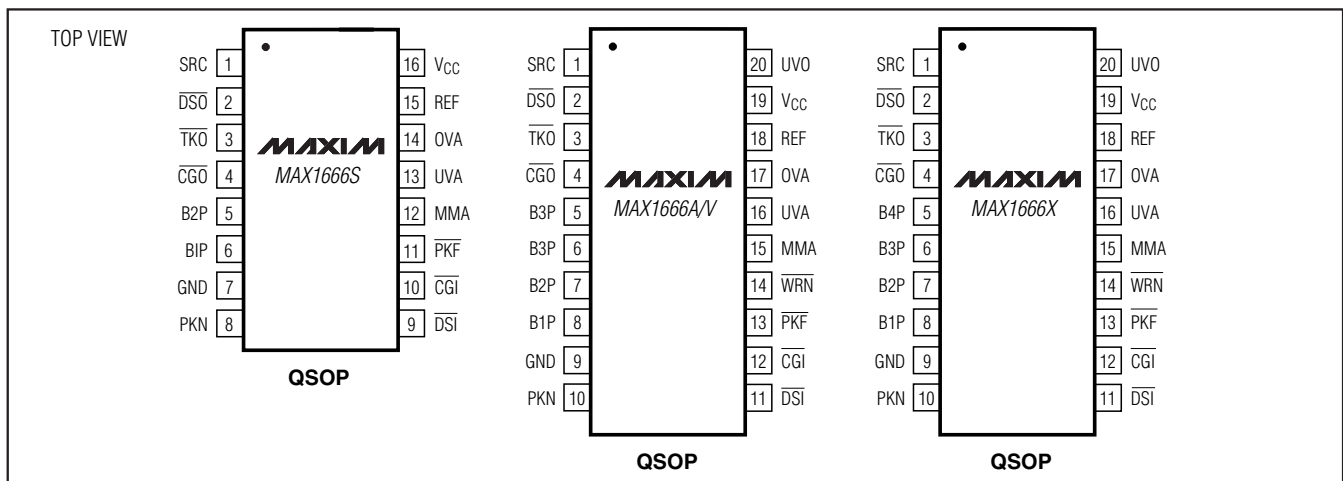

# Advanced Lithium-Ion Battery-Pack Protector

## ABSOLUTE MAXIMUM RATINGS

SRC,  $\overline{DSO}$ ,  $\overline{TKO}$ ,  $\overline{CGO}$ , UVO, PKF,  $\overline{WRN}$  to GND .....-0.3V to +28V  
 VCC, REF, OVA, UVA, MMA to GND .....-0.3V to +6V  
 B4P to B3P .....-0.3V to +6V  
 B3P to B2P .....-0.3V to +6V  
 B2P to B1P .....-0.3V to +6V  
 B1P to GND .....-0.3V to +6V  
 PKN to GND.....±2V

VCC,  $\overline{CGI}$ ,  $\overline{DSI}$  to PKN.....-0.3V to +6V  
 Continuous Power Dissipation ( $T_A = +70^\circ\text{C}$ )  
 16-Pin QSOP (derate 8.3mW/°C above +70°C).....667mW  
 20-Pin QSOP (derate 9.1mW/°C above +70°C).....727mW  
 Operating Temperature Range .....-40°C to +85°C  
 Storage Temperature Range .....-65°C to +150°C  
 Lead Temperature (soldering, 10s).....+300°C

Stresses beyond those listed under "Absolute Maximum Ratings" may cause permanent damage to the device. These are stress ratings only, and functional operation of the device at these or any other conditions beyond those indicated in the operational sections of the specifications is not implied. Exposure to absolute maximum rating conditions for extended periods may affect device reliability.

## ELECTRICAL CHARACTERISTICS

( $V_{SRC} = 16\text{V}$ , each cell voltage  $V_{CELL} = 3.6\text{V}$ , 330k $\Omega$  load at REF,  $T_A = 0^\circ\text{C}$  to  $+85^\circ\text{C}$ , unless otherwise noted. Typical values are at  $T_A = +25^\circ\text{C}$ .)

PARAMETER	SYMBOL	CONDITIONS	MIN	TYP	MAX	UNITS	
Charge-Mode Detection Threshold		$V_{SRC} - V_{B\_P}$	1			V	
SRC Supply Current		$V_{SRC} - V_{B\_P} = 1\text{V}$ , $V_{CGI} = V_{DSI} = \text{GND}$		2	10	$\mu\text{A}$	
		MAX1666A only, $V_{SRC} - V_{B3P} = 1\text{V}$ , $V_{CGI} = 3\text{V}$ , $V_{DSI} = \text{GND}$		2	5		
		MAX1666A only, $V_{SRC} - V_{B3P} = 1\text{V}$ , $V_{DSI} = 3\text{V}$ , $V_{CGI} = \text{GND}$		2	5		
Supply Current	$I_{SUP}$	No faults, long-time average current from the top battery terminal B_P		30	45	$\mu\text{A}$	
Shutdown Supply Current	$I_{SHDN}$				1	$\mu\text{A}$	
VCC Output Voltage	$V_{CC}$	$R_{LOAD} \geq 665\Omega$ , $2\text{V} < V_{CELL} < 4.4\text{V}$	3.09	3.25	3.41	V	
VCC Undervoltage-Lockout Threshold			2.7	2.85	3.0	V	
Reference Output Voltage	$V_{REF}$	Pulse on		1.221		V	
Overvoltage Threshold		Cell voltage rising	OVA = GND	3.980	4.000	4.020	V
			$V_{OVA} = V_{REF} / 2$		4.2		
			OVA = REF	4.378	4.400	4.422	
Overvoltage-Threshold Hysteresis				200		mV	
Undervoltage Threshold		Cell voltage falling	UVA = GND	1.950	2.000	2.050	V
			$V_{UVA} = V_{REF} / 2$		2.500		
			UVA = REF	2.925	3.000	3.075	
Undervoltage-Threshold Hysteresis				100		mV	

# Advanced Lithium-Ion Battery-Pack Protector

MAX1666A/S/V/X

## ELECTRICAL CHARACTERISTICS (continued)

( $V_{SRC} = 16V$ , each cell voltage  $V_{CELL} = 3.6V$ , 330k $\Omega$  load at REF,  $T_A = 0^{\circ}C$  to  $+85^{\circ}C$ , unless otherwise noted. Typical values are at  $T_A = +25^{\circ}C$ .)

PARAMETER	SYMBOL	CONDITIONS	MIN	TYP	MAX	UNITS
$\overline{WRN}$ Early-Warning Threshold		Above undervoltage threshold, cell voltage falling		100		mV
$\overline{WRN}$ Early-Warning-Threshold Hysteresis				200		mV
OVA, UVA, MMA Input Current		OVA, UVA, MMA = REF		0.1	20	nA
Cell Mismatch Threshold		All cells > 2V	MMA = GND	$\pm 0$		mV
			$V_{MMA} = V_{REF} / 2$	$\pm 250$		
			MMA = REF	$\pm 450$	$\pm 500$	
PKN to GND Overdischarge-Current Threshold			270	300	330	mV
PKN to GND Overcharge-Current Threshold			-220	-200	-180	mV
Overcurrent Fault-Timer Delay	$t_{P-DELAY}$		330	550	770	ms
Overdischarge/Overcharge-Current Fault-Blanking Time	$t_{I-DELAY}$		1.6	2.4	3.2	ms
$\overline{DSO}$ , $\overline{CGO}$ , UVO Output Sink Current		No faults, $V_{\overline{DSO}} = V_{\overline{CGO}} = V_{UVO} = 1V$ to 27V	20	30	40	$\mu A$
$\overline{DSO}$ , $\overline{CGO}$ Output Source Current		$V_{\overline{DSO}} = V_{SRC} - 4V$ and $V_{\overline{CGO}} = V_{SRC} - 4V$ , fault condition	2	10		mA
$\overline{DSO}$ , $\overline{CGO}$ , UVO Leakage Current		$V_{\overline{DSO}} = V_{\overline{CGO}} = V_{UVO} = 27V$ , fault condition			0.2	$\mu A$
$\overline{TKO}$ Pulldown Resistance, MAX1666S/V/X			100	200		k $\Omega$
$\overline{TKO}$ Sink Current, MAX1666A Only		$V_{\overline{TKO}} = 16V$	1	2.5		mA
$\overline{TKO}$ Leakage Current, MAX1666A Only		$V_{\overline{TKO}} = 16V$ , $V_{CGI} = 3V$			1	$\mu A$
Minimum B3P Voltage for $\overline{TKO}$ Low, MAX1666A Only		$V_{SRC} = V_{B3P} + 1V$ , $I_{\overline{TKO}} = 0.5mA$		2.4	3.6	V
$\overline{TKO}$ Source Current		$\overline{TKO} = GND$	1	8		mA
$\overline{DSI}$ , $\overline{CGI}$ Input High Voltage		Referenced to PKN	2			V
$\overline{DSI}$ , $\overline{CGI}$ Input Low Voltage		Referenced to PKN			0.45	V
$\overline{DSI}$ , $\overline{CGI}$ Input Current		$V_{\overline{DSI}}$ , $V_{\overline{CGI}} = 5V$			1	$\mu A$
$\overline{WRN}$ Sink Current		Fault condition, $V_{\overline{WRN}} = 0.4V$	2	4		mA
$\overline{PKF}$ Sink Current		Fault condition, $V_{\overline{PKF}} = 0.4V$	4	8		mA
$\overline{PKF}$ , $\overline{WRN}$ Leakage Current		$V_{\overline{PKF}} = V_{\overline{WRN}} = 27V$			0.2	$\mu A$
Undervoltage, Overvoltage, or Mismatch Fault, to $\overline{DSO}$ , $\overline{CGO}$ , $\overline{TKO}$ Transition Delay	$t_{F-DELAY}$	Fault persistent for four consecutive sample periods	180	320	460	ms

# Advanced Lithium-Ion Battery-Pack Protector

**MAX1666A/S/V/X**

## ELECTRICAL CHARACTERISTICS

( $V_{SRC} = 16V$ , each cell voltage  $V_{CELL} = 3.6V$ ,  $330k\Omega$  load at REF,  $T_A = -40^{\circ}C$  to  $+85^{\circ}C$ , unless otherwise noted.) (Note 1)

PARAMETER	SYMBOL	CONDITIONS	MIN	TYP	MAX	UNITS
Charge-Mode Detection Threshold		$V_{SRC} - V_{B\_P}$	1			V
SRC Supply Current		$V_{SRC} - V_{B\_P} = 1V$ , $V_{CGI} = V_{DSI} = GND$			10	$\mu A$
		MAX1666A only, $V_{SRC} - V_{B3P} = 1V$ , $V_{CGI} = 3V$ , $V_{DSI} = GND$			5	
		MAX1666A only, $V_{SRC} - V_{B3P} = 1V$ , $V_{DSI} = 3V$ , $V_{CGI} = GND$			5	
Supply Current	$I_{SUP}$	No faults, long-time average current from the top battery terminal B_P			45	$\mu A$
Shutdown Supply Current	$I_{SHDN}$				1	$\mu A$
$V_{CC}$ Output Voltage	$V_{CC}$	$R_{LOAD} \geq 665\Omega$ , $2V < V_{CELL} < 4.4V$	3.09		3.41	V
$V_{CC}$ Undervoltage-Lockout Threshold			2.7		3.0	V
Overvoltage Threshold		OVA = GND	3.975		4.025	V
		OVA = REF	4.373		4.427	
Undervoltage Threshold		UVA = GND	1.950		2.050	V
		UVA = REF	2.925		3.075	
OVA, UVA, MMA Leakage		OVA, UVA, MMA = REF			20	nA
Cell Mismatch Threshold		All cells $> 2V$ , MMA = REF	$\pm 450$		$\pm 550$	mV
PKN to GND Overdischarge-Current Threshold			270		330	mV
PKN to GND Overcharge-Current Threshold			-220		-180	mV
Overcurrent Fault-Timer Delay	$t_{P-DELAY}$		330		770	ms
Overdischarge/Overcharge-Current Fault-Blanking Time	$t_{I-DELAY}$		1.6		3.2	ms
$\overline{DSO}$ , $\overline{CGO}$ , UVO Output Sink Current		No faults; $V_{\overline{DSO}}$ , $V_{\overline{CGO}}$ , $V_{UVO} = 1V$ to $27V$	20		40	$\mu A$
$\overline{DSO}$ , $\overline{CGO}$ Output Source Current		$V_{\overline{DSO}} = V_{SRC} - 4V$ and $V_{\overline{CGO}} = V_{SRC} - 4V$ , fault condition	2			mA
$\overline{DSO}$ , $\overline{CGO}$ , UVO Leakage Current		$V_{\overline{DSO}} = V_{\overline{CGO}} = V_{UVO} = 27V$ , fault condition			0.2	$\mu A$

# Advanced Lithium-Ion Battery-Pack Protector

**MAX1666A/S/V/X**

## ELECTRICAL CHARACTERISTICS

( $V_{SRC} = 16V$ , each cell voltage  $V_{CELL} = 3.6V$ ,  $330k\Omega$  load at REF,  $T_A = -40^\circ C$  to  $+85^\circ C$ , unless otherwise noted.) (Note 1)

PARAMETER	SYMBOL	CONDITIONS	MIN	TYP	MAX	UNITS
$\overline{TKO}$ Pulldown Resistance, MAX1666S/V/X			100			k $\Omega$
$\overline{TKO}$ Sink Current, MAX1666A Only		$V_{\overline{TKO}} = 16V$	1			mA
Minimum B3P Voltage for $\overline{TKO}$ Low		$V_{SRC} = V_{B3P} + 1V$ , $I_{\overline{TKO}} = 0.5mA$			3.6	V
$\overline{TKO}$ Source Current		$\overline{TKO} = GND$	1			mA
$\overline{DSI}$ , $\overline{CGI}$ Input High Voltage		Referenced to PKN	2			V
$\overline{DSI}$ , $\overline{CGI}$ Input Low Voltage		Referenced to PKN			0.45	V
$\overline{DSI}$ , $\overline{CGI}$ Input Current		$V_{DSI} = V_{CGI} = 5V$			1	$\mu A$
$\overline{WRN}$ Sink Current		Fault condition, $V_{\overline{WRN}} = 0.4V$	2			mA
$\overline{PKF}$ Sink Current		Fault condition, $V_{\overline{PKF}} = 0.4V$	4			mA
$\overline{PKF}$ , $\overline{WRN}$ Leakage Current		$V_{\overline{PKF}} = V_{\overline{WRN}} = 27V$			0.2	$\mu A$
Undervoltage, Overvoltage, or Mismatch Fault, to $\overline{DSO}$ , $\overline{CGO}$ , $\overline{TKO}$ Transition Delay	$t_F$ -DELAY	Fault persistent for four consecutive sample periods	180		460	ms

**Note 1:** Specifications to  $-40^\circ C$  are guaranteed by design, not production tested.

# Advanced Lithium-Ion Battery-Pack Protector

## Typical Operating Characteristics

( $T_A = +25^\circ\text{C}$ , unless otherwise noted.)

**SHUTDOWN SUPPLY CURRENT vs. TEMPERATURE**

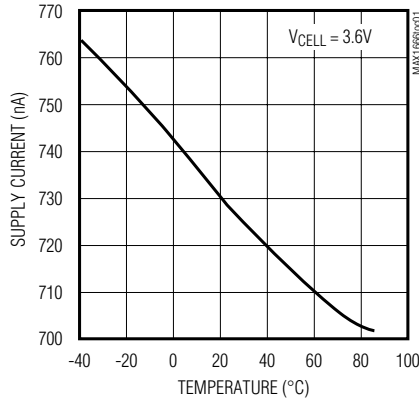

**SUPPLY CURRENT vs. TEMPERATURE**

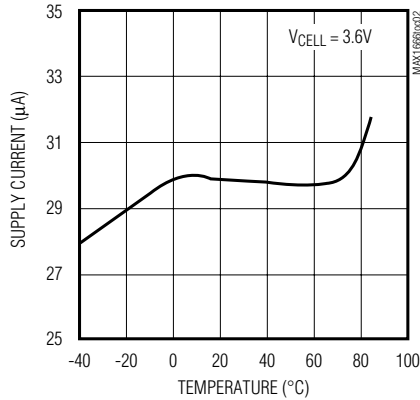

**UNDERVOLTAGE THRESHOLD vs. TEMPERATURE**

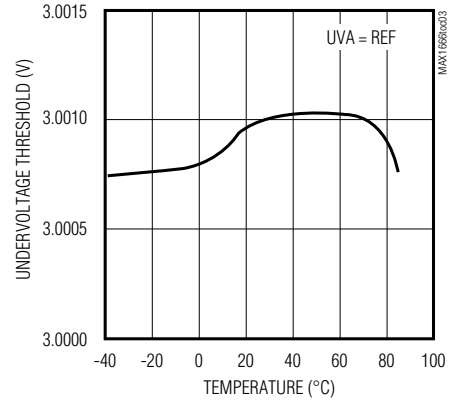

**OVERVOLTAGE THRESHOLD vs. TEMPERATURE**

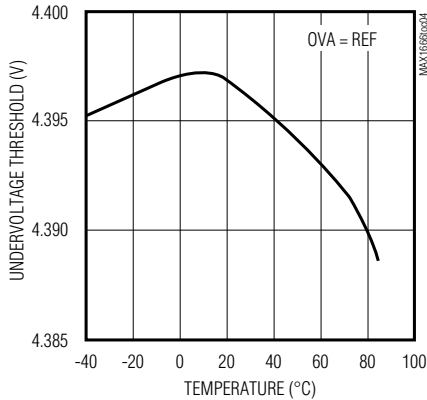

**MISMATCH VOLTAGE THRESHOLD vs. TEMPERATURE**

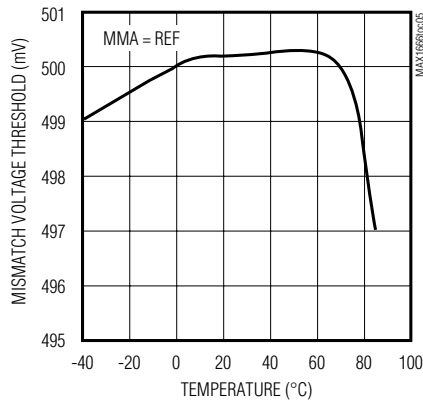

**OVERCHARGE THRESHOLD vs. TEMPERATURE**

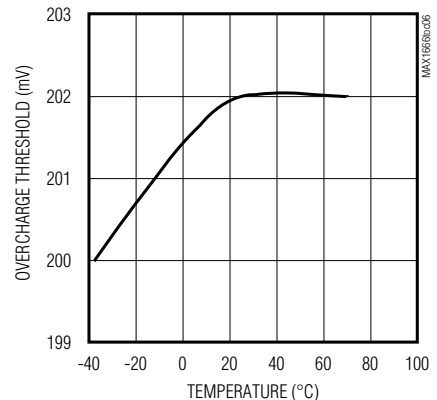

**OVERDISCHARGE THRESHOLD vs. TEMPERATURE**

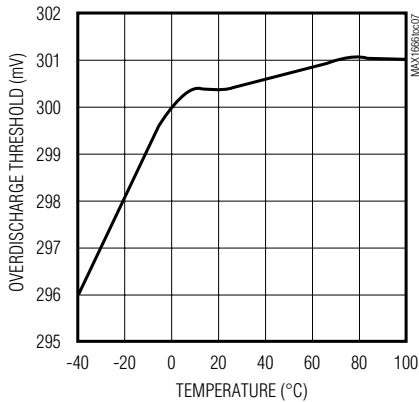

**OVERDISCHARGE PROTECTION**

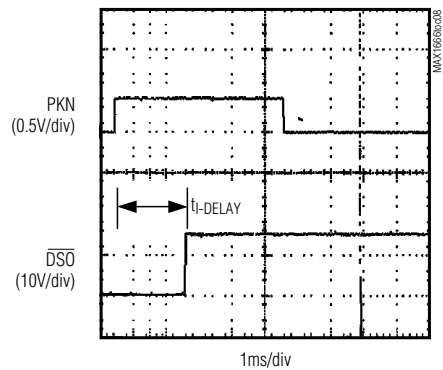

**OVERDISCHARGE RECOVERY TIME**

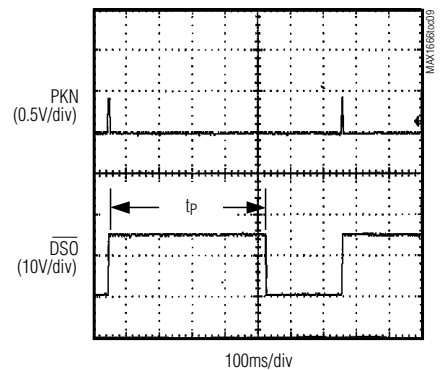

# Advanced Lithium-Ion Battery-Pack Protector

## Typical Operating Characteristics (continued)

( $T_A = +25^\circ\text{C}$ , unless otherwise noted.)

MAX1666A/S/W/X

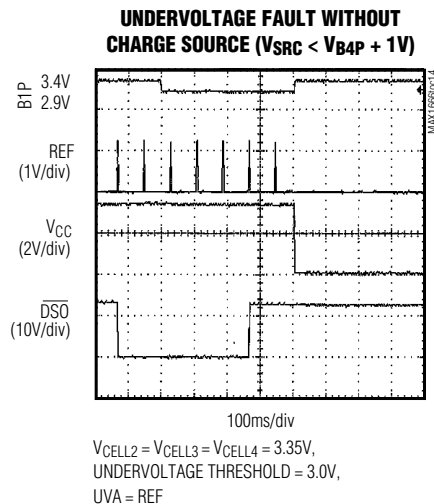
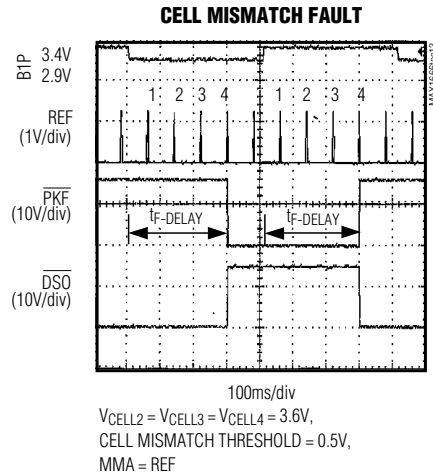
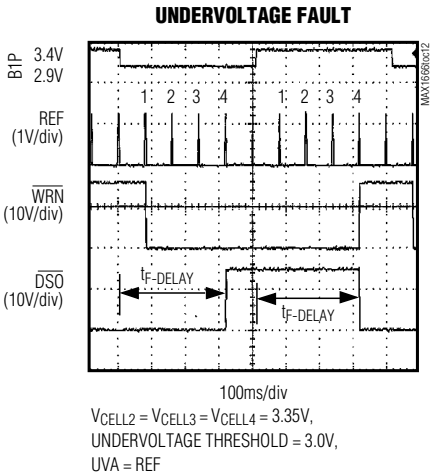
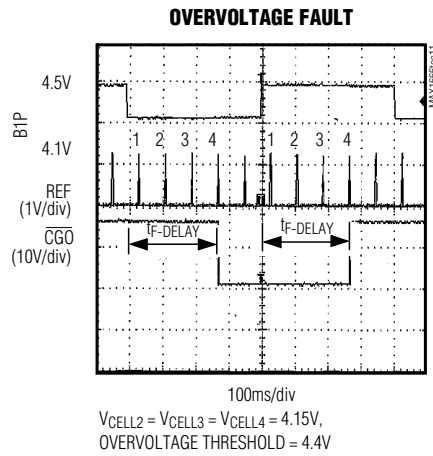
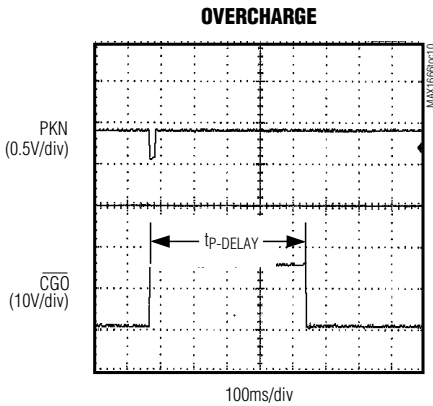

# Advanced Lithium-Ion Battery-Pack Protector

MAX1666A/S/V/X

## Pin Description

MAX1666X	PIN		NAME	FUNCTION
	MAX1666AV	MAX1666S		
1	1	1	SRC	Charge Source Input. Provides current for gate drivers $\overline{DSO}$ , $\overline{TKO}$ , $\overline{CGO}$ , and UVO.
2	2	2	$\overline{DSO}$	Discharge Driver Output. Drives external P-channel MOSFET to control discharge.
3	3	3	$\overline{TKO}$	Trickle-Charge Driver Output. Drives external P-channel MOSFET to control trickle-charge current. MAX1666A requires an external pullup resistor of 470k $\Omega$ .
4	4	4	$\overline{CGO}$	Fast-Charge Driver Output. Drives external P-channel MOSFET to control fast charge.
5	—	—	B4P	Cell 4 Positive Input. Power supply input for MAX1666X.
6	5, 6	—	B3P	Cell 3 Positive Input. Power supply input for MAX1666A/V.
7	7	5	B2P	Cell 2 Positive Input. Power supply input for MAX1666S.
8	8	6	B1P	Cell 1 Positive Input
9	9	7	GND	Ground
10	10	8	PKN	Battery Pack Negative Terminal. Connect to bottom of current-sense resistor. Ground reference for logic inputs $\overline{DSI}$ and $\overline{CGI}$ .
11	11	9	$\overline{DSI}$	Discharge Control Input
12	12	10	$\overline{CGI}$	Charge Control Input
13	13	11	$\overline{PKF}$	Pack Fail Output. $\overline{PKF}$ goes low when any cell voltage exceeds the mismatch threshold or when a shorted cell is detected.
14	14	—	$\overline{WRN}$	Undervoltage/Overvoltage Warning Output
15	15	12	MMA	Mismatch Adjust Input. Set the mismatch threshold by a resistor-divider from REF to GND.
16	16	13	UVA	Undervoltage Adjust Input. Set the undervoltage threshold with a resistor-divider from REF to GND.
17	17	14	OVA	Overvoltage Adjust Input. Set the overvoltage threshold with a resistor-divider from REF to GND.
18	18	15	REF	Reference Voltage Output. Minimize PC board stray capacitance on this node.
19	19	16	V <sub>CC</sub>	3.3V Linear Regulator Output. Bypass with a 0.47 $\mu$ F min capacitor to GND.
20	20	—	UVO	Undervoltage Fault Output

# Advanced Lithium-Ion Battery-Pack Protector

MAX1666A/S/W/X

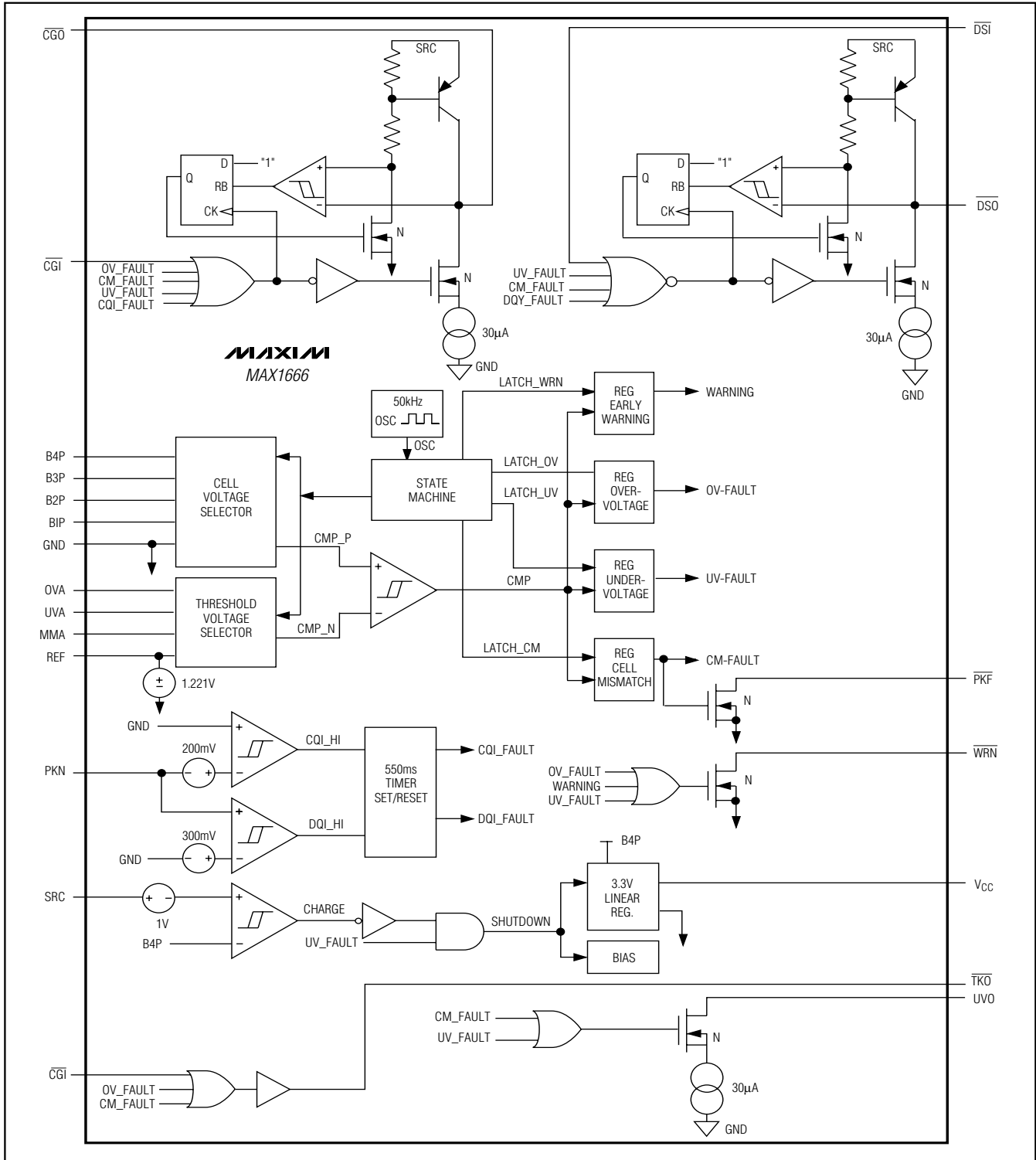

Figure 1. Functional Diagram

# Advanced Lithium-Ion Battery-Pack Protector

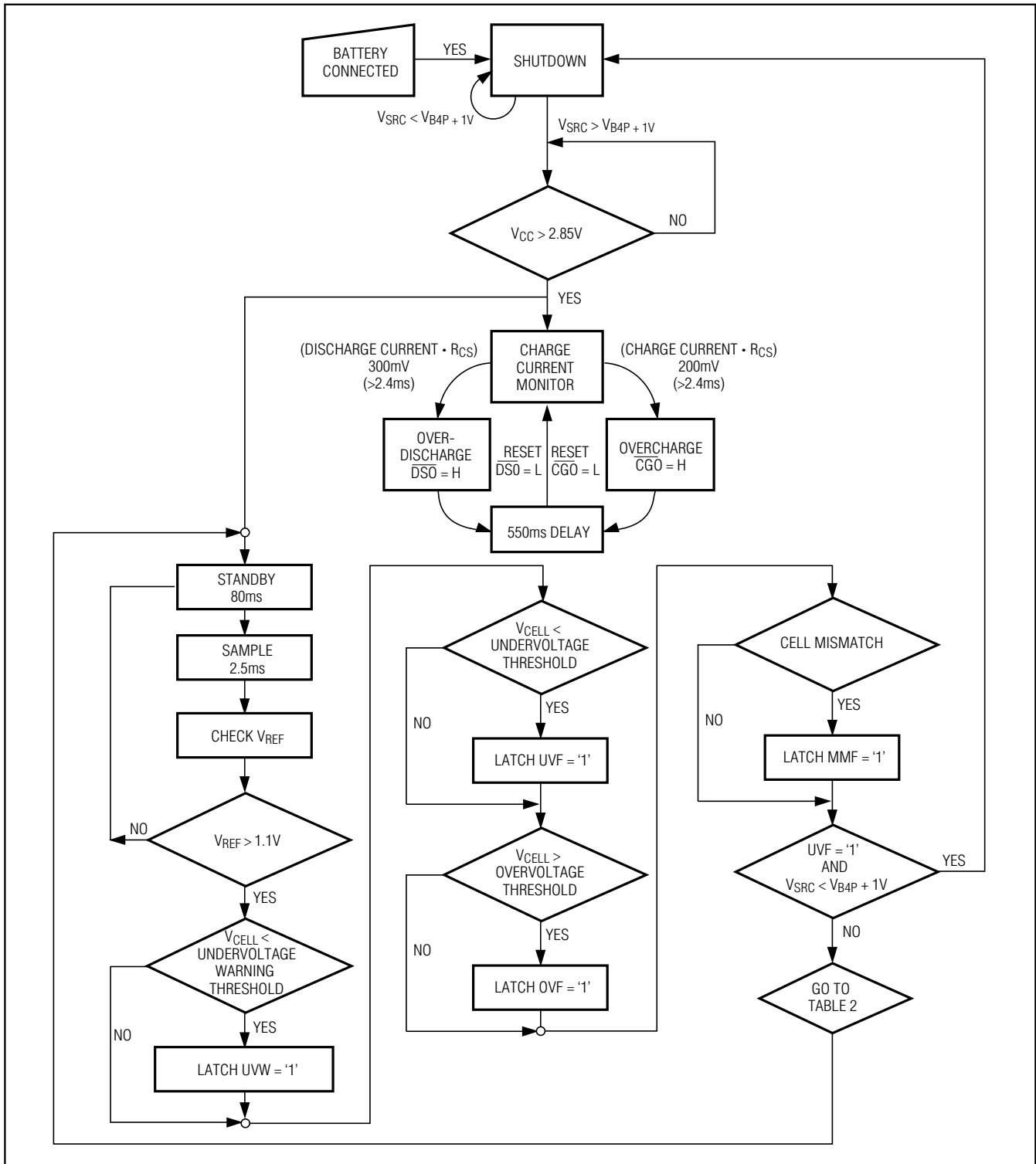

Figure 2. Cell Fault Monitor

# Advanced Lithium-Ion Battery-Pack Protector

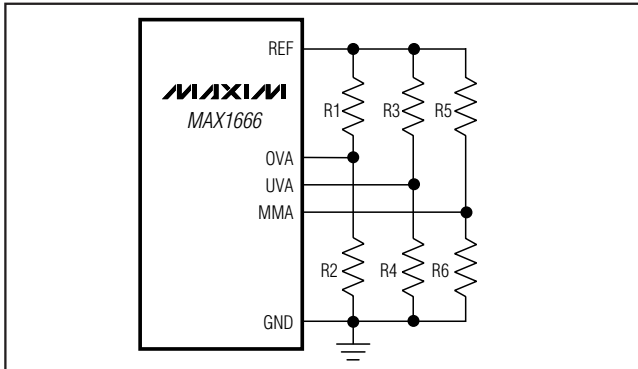

Figure 3. Using an External Resistor-Divider to Adjust Overvoltage Threshold

## Detailed Description

The MAX1666 battery-pack protectors supervise the charging and discharging processes of Li+ battery cells. Designed for 2-, 3-, and 4-cell applications, these devices monitor the voltage across each cell to provide protection against undervoltage, overvoltage, and overcurrent damage.

Control pins  $\overline{\text{CGO}}$ ,  $\overline{\text{TKO}}$ , and  $\overline{\text{DSO}}$  allow control of external MOSFET gates. This allows fast charging, trickle charging, and discharging processes (see the *Typical Operating Circuits*). The voltage of each cell is measured individually. Also, each cell is measured differentially between every other cell of the pack.

The MAX1666 contains a state machine, a voltage regulator, an oscillator, and other logic functions to selectively drive  $\overline{\text{CGO}}$ ,  $\overline{\text{UVO}}$ ,  $\overline{\text{TKO}}$ ,  $\overline{\text{DSO}}$ ,  $\overline{\text{WRN}}$ , and  $\overline{\text{PKF}}$  (Figure 1).

## Modes of Operation

### Shutdown Mode

The MAX1666 goes into shutdown mode when a battery pack is first connected. The quiescent current is less than 1 $\mu\text{A}$ . All circuitry is inactive except the com-

parator monitoring  $V_{\text{SRC}}$  and the top-cell voltage. The MAX1666 remains in shutdown mode as long as  $V_{\text{SRC}}$  is less than the top-cell voltage. When SRC is connected to an external charger and  $V_{\text{SRC}}$  is 1V above the top-cell voltage, the device goes into standby mode.

The MAX1666 returns to shutdown mode under two conditions: the battery is disconnected and then re-connected, or the device detects an undervoltage fault and no charge source.

### Normal Mode

The standby state activates the bias circuitry, overcurrent comparator, and timer. The standby state lasts 80ms, then the MAX1666 goes into the sample state for 2.5ms.

Within the 2.5ms, the MAX1666 checks for overvoltage, undervoltage, and mismatch between cells sequentially, and it stores the results in internal latches. The MAX1666 drives the outputs according to the faults (if any) detected by reading the latches (Figure 2) at the end of the sample state. Then the MAX1666 returns to the standby state.

### Overvoltage Protection

The MAX1666 provides overvoltage protection to avoid overcharging of any cell. When any cell is at overvoltage,  $\overline{\text{CGO}}$  and  $\overline{\text{TKO}}$  go high, turning off the external MOSFETs and stopping the charging process (see the *Typical Operating Circuits*).  $\overline{\text{WRN}}$  goes low. Overvoltage is set when any cell voltage exceeds the overvoltage threshold.

Overvoltage threshold is linearly adjustable through an external 1% resistor-divider (Figure 3) from REF. Determine the overvoltage threshold ( $V_{\text{OVT}}$ ) required.  $V_{\text{OVT}}$  must be between 4V and 4.4V. Set  $R_{\text{TOTAL}} = R1 + R2 = 1\text{M}\Omega$ . Calculate R1 and R2 as follows:

$$R2 = [(V_{\text{OVT}} - 4\text{V}) / (4.4\text{V} - 4\text{V})] \cdot R_{\text{TOTAL}}$$

$$R1 = R_{\text{TOTAL}} - R2$$

Table 1. Operating Modes

MODE	STATE	TIME (ms)	TYPICAL QUIESCENT CURRENT ( $\mu\text{A}$ )	CONDITION
Normal	Standby	80	24	Only bias circuitry, overcurrent comparator, and timer are active.
	Sample	2.5	250	All circuitry active.
Shutdown	—	—	0.7	All circuitry inactive. Device enters shutdown when it detects an undervoltage fault and $V_{\text{SRC}} < V_{\text{TOP-CELL}} + 1\text{V}$ (no charge source).

# Advanced Lithium-Ion Battery-Pack Protector

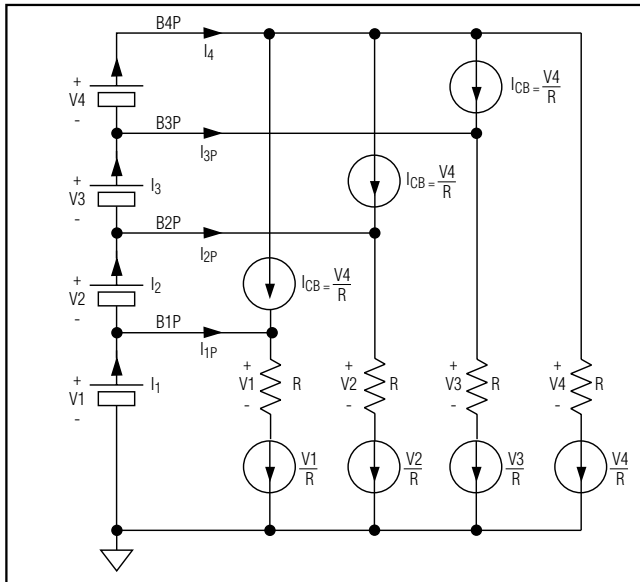

Figure 4. Cell Voltage Sampling

Maximum mismatch of 1% external resistor-dividers is  $\pm 2\%$ . The external adjusted overvoltage-threshold accuracy includes the internal overvoltage-threshold accuracy ( $\pm 0.5\%$ ) and the error due to the external resistor-divider multiplied by maximum adjustment:

$$\pm 2\% \frac{4.4V - 4.0V}{4.4V} = \pm 0.2\%$$

The total external adjusted overvoltage-threshold ( $V_{OVT}$ ) accuracy is  $\pm 0.7\%$ .

## Undervoltage Protection

The MAX1666 provides undervoltage protection to avoid overdischarging the cells. When any cell is under voltage,  $\overline{UVO}$ ,  $\overline{DSO}$ , and  $\overline{CGO}$  go high, turning off the external charging and discharging MOSFETs.  $\overline{TKO}$  remains low to keep the trickle-charge current on. Undervoltage threshold is linearly adjustable through an external resistor-divider (Figure 3) from REF. Determine the undervoltage threshold ( $V_{UVT}$ ) required.  $V_{UVT}$  must be between 2V and 3V. Set  $R_{TOTAL} = R3 + R4 = 1M\Omega$ . Calculate R3 and R4 as follows:

$$R4 = [(V_{UVT} - 2V) / (3V - 2V)] R_{TOTAL}$$

$$R3 = R_{TOTAL} - R4$$

Maximum mismatch of 1% external resistor-dividers is  $\pm 2.0\%$ , and the error due to the external resistor-divider multiplied by maximum adjustment is  $\pm 2\% (3V - 2V) / 3V = \pm 0.7\%$ . The total external adjusted undervoltage-

threshold ( $V_{UVT}$ ) accuracy including the internal undervoltage-threshold accuracy ( $\pm 2.5\%$ ) is  $\pm 3.2\%$ .

## Undervoltage Warning

When any cell drops to 100mV above the undervoltage threshold,  $\overline{WRN}$  goes low.  $\overline{WRN}$  returns high when all cells are 300mV above the undervoltage threshold.

## Cell-Mismatch Protection

The MAX1666 disables charging or discharging when mismatch occurs. When any two cells are mismatched,  $\overline{TKO}$ ,  $\overline{CGO}$ ,  $\overline{UVO}$ , and  $\overline{DSO}$  go high, turning off the external MOSFETs.  $\overline{PKF}$  goes low.  $\overline{PKF}$  has a strong pulldown current ( $>4mA$ ), and can be used to control an external thermal fuse. The cell-mismatch threshold is linearly adjustable through an external resistor-divider (Figure 3) from REF. Determine the cell-mismatch threshold ( $V_{CMT}$ ) required.  $V_{CMT}$  has to be between 0 and 500mV. Set  $R_{TOTAL} = R5 + R6 = 1M\Omega$ . Calculate R5 and R6:

$$R6 = (V_{CMT} / 500mV) R_{TOTAL}$$

$$R5 = R_{TOTAL} - R6$$

Maximum mismatch of a 1% external resistor-divider is  $\pm 2\%$ . The total external adjusted cell-mismatch threshold accuracy, including the internal cell-mismatch threshold accuracy ( $\pm 10\%$ ), is  $\pm 12\%$ .

## Cell Voltage Sampling

The MAX1666 does not introduce cell mismatch. When the battery cells are matched, the MAX1666 draws close to zero current from the intermediate cells. Figure 4 shows a simplified diagram of the voltage sampling scheme:

$$B4P: I4 = 3I_{CB} + V4 / R = 4V4 / R = \text{BAT4 current}$$

$$B3P: I3 = I3P + I4 = \text{BAT3 current}$$

$$I3P + I_{CB} = V3 / R \Rightarrow I3P = V3 / R - V4 / R$$

$$I3 = I4 + (V3 - V4) / R = (3V4 + V3) / R$$

$$B2P: I2 = I2P + I3 = \text{BAT2 current}$$

$$I2P + I_{CB} = V2 / R \Rightarrow I2P = V2 / R - V4 / R$$

$$I2 = I3 + V2 / R - V4 / R = I4 + (V3 - V4) / R + (V2 - V4) / R = (2V4 + V3 + V2) / R$$

$$B1P: I1 = I1P + I2 = \text{BAT1 current}$$

$$I1P + I_{CB} = V1 / R \Rightarrow I1P = V1 / R - V4 / R$$

$$I1 = I2 + V1 / R - V4 / R = I4 + (V3 - V4) / R + (V2 - V4) / R + (V1 - V4) / R$$

$$= (V4 + V3 + V2 + V1) / R$$

$$\text{when } V1 = V2 = V3 = V4, I1P = I2P = I3P = 0, \text{ and } I1 = I2 = I3 = I4 = 4V4 / R$$



# Advanced Lithium-Ion Battery-Pack Protector

## Overcharge/Overdischarge Current Protection

The MAX1666 checks for overcharge or overdischarge current in standby and sample states. The thresholds are factory preset to 200mV and 300mV, respectively. A charge current makes PKN go below GND. A discharge current makes PKN go above GND. When PKN exceeds the threshold, a fault is acknowledged.  $\overline{\text{CGO}}$  goes high when the overcharge threshold is exceeded.  $\overline{\text{DSO}}$  goes high when the overdischarge threshold is exceeded. An internal 550ms timer starts. At the end of 550ms,  $\overline{\text{DSO}}$  or  $\overline{\text{CGO}}$  goes low while the MAX1666 rechecks for an overcharge/overdischarge fault. A persistent fault causes  $\overline{\text{DSO}}$  and  $\overline{\text{CGO}}$  to return high and restarts the 550ms timer again.

### Truth Table

The MAX1666 has a total of eight signal inputs and six outputs. Table 2 lists all the possible states.

## Applications Information

### Choosing an External MOSFET

The external P-channel MOSFETs act as a gated switch to enable or disable the charging/discharging process.

Table 3. MOSFET Selection

P-CHANNEL MOSFETs	MAXIMUM DRAIN CURRENT (A)
IRF7404	5.3
IRF7406	4.7
Si4431	4.5
Si4947 (dual)	2.5 EA

$\overline{\text{CGO}}$  controls the MOSFET for normal charging of the battery.  $\overline{\text{TKO}}$  controls the MOSFET for trickle charge of the cells.  $\overline{\text{DSO}}$  controls the discharging MOSFET. Use different MOSFETs to optimize each function depending on the maximum charge and discharge rates. Table 3 lists some suitable MOSFETs in a small 8-pin SO package.

### Layout Considerations and Bypassing

As with all PC board designs, a careful layout is suggested. Minimize lead lengths to reduce losses in the traces.

# Advanced Lithium-Ion Battery-Pack Protector

## Typical Operating Circuits

**MAX1666A/S/W/X**

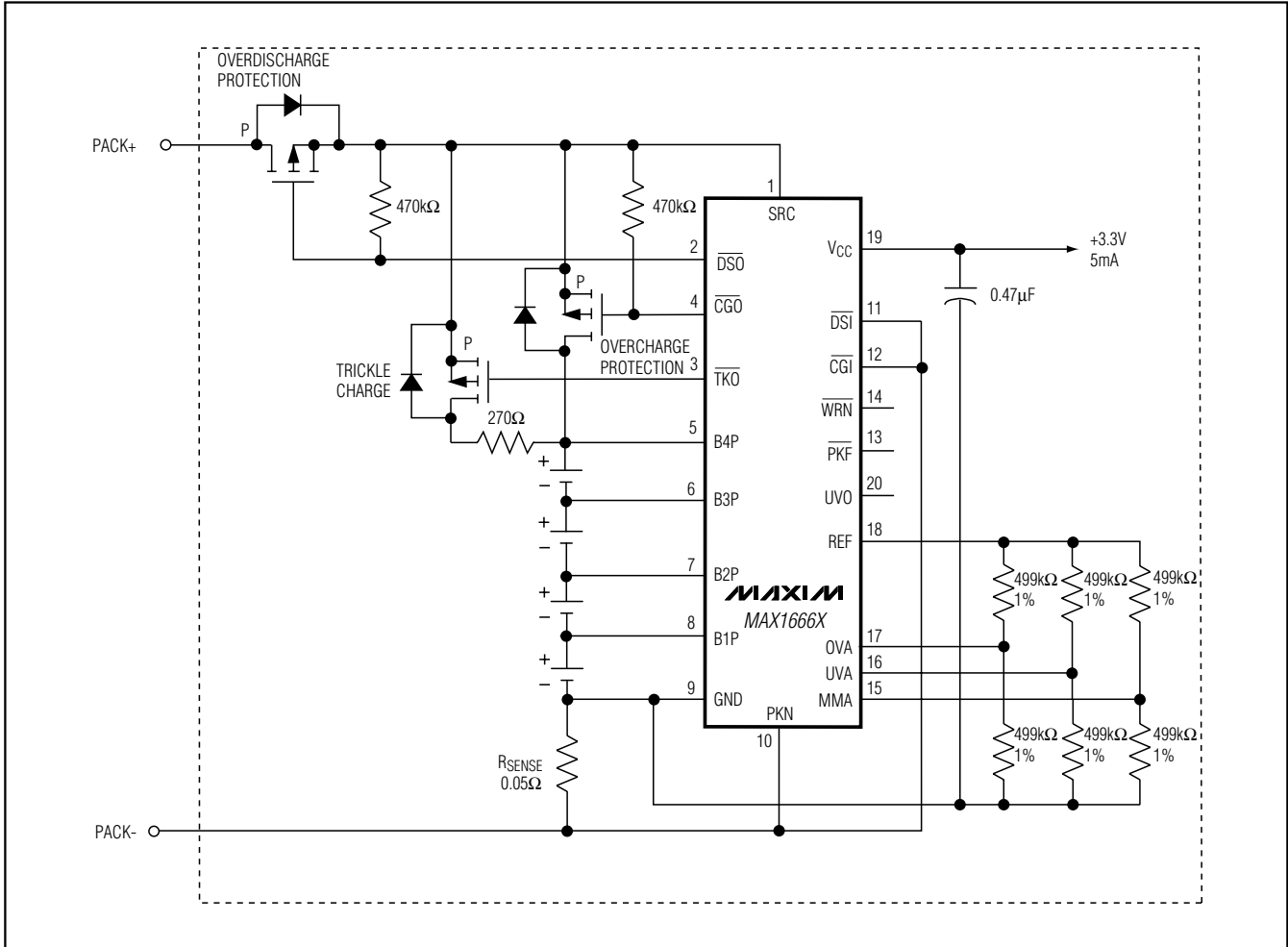

# Advanced Lithium-Ion Battery-Pack Protector

## Typical Operating Circuits (continued)

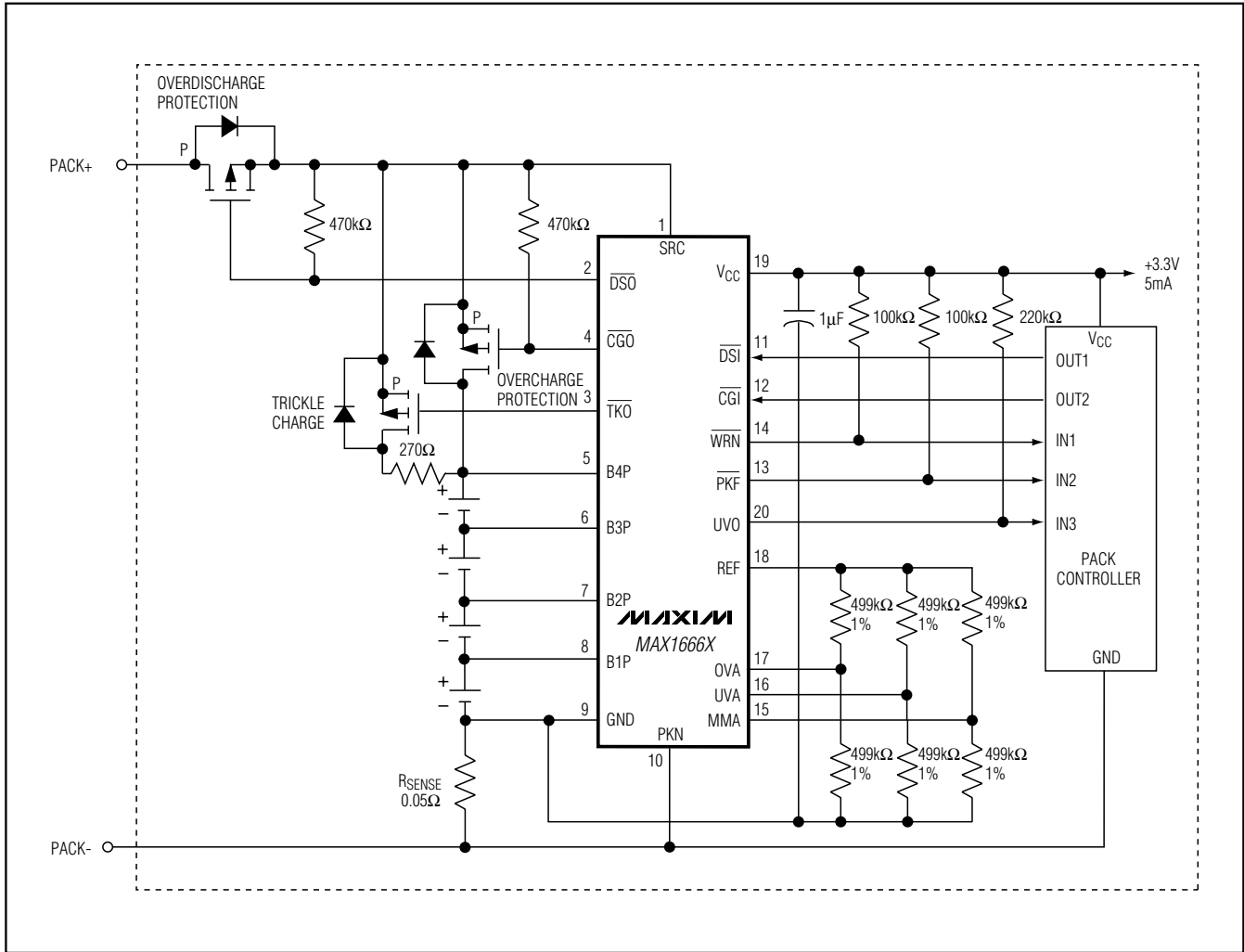

### Chip Information

TRANSISTOR COUNT: 4835

# Advanced Lithium-Ion Battery-Pack Protector

## Package Information

MAX1666A/S/V/X

QSOP8PS

DIM	INCHES		MILLIMETERS	
	MIN	MAX	MIN	MAX
A	.061	.068	1.55	1.73
A1	.004	.0098	0.102	0.249
A2	.055	.061	1.40	1.55
B	.008	.012	0.20	0.30
C	.0075	.0098	0.191	0.249
D	SEE VARIATIONS			
E	.150	.157	3.81	3.99
e	.025 BSC		0.635 BSC	
H	.230	.244	5.84	6.20
h	.010	.016	0.25	0.41
L	.016	.035	0.41	0.89
N	SEE VARIATIONS			
α	0°	8°	0°	8°

		INCHES		MILLIMETERS		N
		MIN.	MAX.	MIN.	MAX.	
D	.189	.196	4.80	4.98	16	AB
S	.0020	.0070	0.05	0.18		
D	.337	.344	8.56	8.74	20	AD
S	.0500	.0550	1.270	1.397		
D	.337	.344	8.56	8.74	24	AE
S	.0250	.0300	0.635	0.762		
D	.386	.393	9.80	9.98	28	AF
S	.0250	.0300	0.635	0.762		

**NOTES:**  
 1). D & E DO NOT INCLUDE MOLD FLASH OR PROTRUSIONS.  
 2). MOLD FLASH OR PROTRUSIONS NOT TO EXCEED .006" PER SIDE.  
 3). CONTROLLING DIMENSIONS: INCHES.  
 4). MEETS JEDEC MO137.

**DALLAS SEMICONDUCTOR** **MAXIM**  
PROPRIETARY INFORMATION  
TITLE:  
 PACKAGE OUTLINE, QSOP .150", .025" LEAD PITCH  
APPROVAL: DOCUMENT CONTROL NO. 21-0055 REV. E 1/1

Maxim cannot assume responsibility for use of any circuitry other than circuitry entirely embodied in a Maxim product. No circuit patent licenses are implied. Maxim reserves the right to change the circuitry and specifications without notice at any time.

Maxim Integrated Products, 120 San Gabriel Drive, Sunnyvale, CA 94086 408-737-7600 \_\_\_\_\_ 17

## Looking for pricing, stock, or lifecycle information?

Click below to explore more details on WIN SOURCE:

 [View MAX1666VEEP on WIN SOURCE](#)

 [Maxim Integrated](#) Information

## Optimize Your Supply Chain with WIN SOURCE Solutions

-  Global Sourcing Solution
-  Obsolete Management
-  Cost Control Management
-  Shortage Management
-  Alternative Solution
-  Excess Inventory Management