



3V to 5V Regulating Charge Pumps for SIM Cards

General Description

The MAX1686 provides power for dual-voltage subscriber ID module (SIM) cards in portable applications such as GSM cellular phones. Designed to reside in the portable unit (cellular phone handset), the 1MHz charge pump converts a 2.7V to 4.2V input to regulated 5V output. The MAX1686H has a nominal output voltage of 5.0V, while the MAX1686 is set to 4.75V to reduce SIM-card current drain. The charge pump has only 45 μ A quiescent supply current, which reduces to 3 μ A when a 3V-capable SIM card is being powered and the charge pump is disabled. An internal input/output shorting switch provides power for 3V SIM cards.

The MAX1686/MAX1686H require only three external capacitors around their space-saving, thin (1mm) 8-pin μ MAX packages.

Applications

GSM Cellular Phones

PCS Phones

Portable POS Terminals

Personal Communicators

Typical Operating Circuit

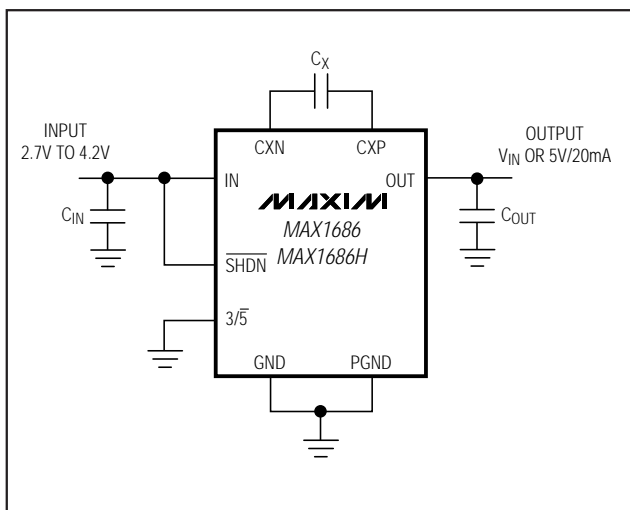

Features

- ◆ 2.7V to 4.2V Input Range
- ◆ 12mA min Charge-Pump Output Current
- ◆ 45 μ A Quiescent Supply Current
- ◆ 0.1 μ A Supply Current in Shutdown Mode
- ◆ 5.0V Regulated Charge-Pump Output (MAX1686H)
4.75V Regulated Charge-Pump Output (MAX1686)
- ◆ Input-Output Shorting Switch for 3V Cards
- ◆ Small External Components
(Uses a 0.047 μ F, 0.1 μ F, and a 2.2 μ F Capacitor)
- ◆ Output Driven to Ground in Shutdown Mode
- ◆ Super-Small 8-Pin μ MAX Package
- ◆ Soft-Start and Short-Circuit Protection

Ordering Information

PART	TEMP. RANGE	PIN-PACKAGE
MAX1686EUA	-40°C to +85°C	8 μ MAX
MAX1686HEUA	-40°C to +85°C	8 μ MAX

Pin Configuration

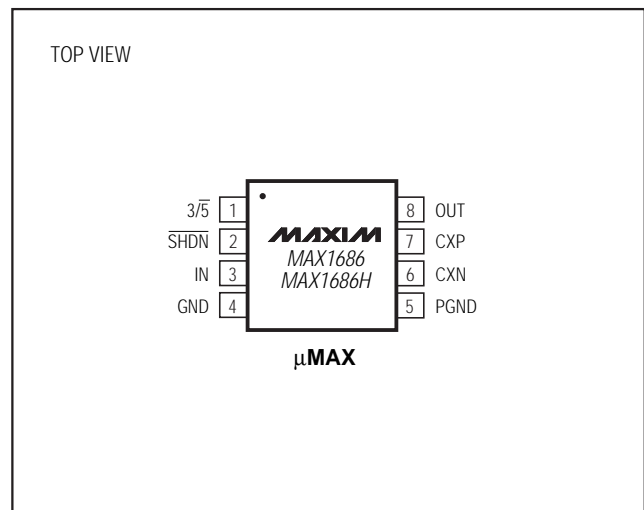

MAX1686/MAX1686H

3V to 5V Regulating Charge Pumps for SIM Cards

ABSOLUTE MAXIMUM RATINGS

IN, OUT, $\overline{\text{SHDN}}$, 3/5 to GND.....-0.3V to +6V
 CXP to GND.....-0.3V to ($V_{\text{OUT}} + 0.3\text{V}$)
 CXN to GND.....-0.3V to ($V_{\text{IN}} + 0.3\text{V}$)
 PGND to GND.....-0.3V to + 0.3V
 OUT Short Circuit to GND.....Continuous
 IN-to-OUT Current.....50mA

Continuous Power Dissipation ($T_A = +70^\circ\text{C}$)
 8-Pin μMAX (derate 4.1mW/ $^\circ\text{C}$ above $+70^\circ\text{C}$).....330mW
 Operating Temperature Range
 MAX1686EUA/MAX1686HEUA.....-40 $^\circ\text{C}$ to +85 $^\circ\text{C}$
 Junction Temperature.....+150 $^\circ\text{C}$
 Storage Temperature Range.....-65 $^\circ\text{C}$ to +165 $^\circ\text{C}$
 Lead Temperature (soldering, 10sec).....+300 $^\circ\text{C}$

Stresses beyond those listed under "Absolute Maximum Ratings" may cause permanent damage to the device. These are stress ratings only, and functional operation of the device at these or any other conditions beyond those indicated in the operational sections of the specifications is not implied. Exposure to absolute maximum rating conditions for extended periods may affect device reliability.

ELECTRICAL CHARACTERISTICS

($V_{\text{IN}} = V_{\overline{\text{SHDN}}} = 3.3\text{V}$, 3/5 = GND, $C_X = 0.22\mu\text{F}$, $C_{\text{OUT}} = 10\mu\text{F}$ (see Applications Information section to use smaller capacitors), $T_A = T_{\text{MIN}}$ to T_{MAX} , unless otherwise noted. Typical values are at $T_A = +25^\circ\text{C}$.) (Note 1)

PARAMETER	CONDITIONS	MIN	TYP	MAX	UNITS	
Input Voltage Range		2.7		4.2	V	
Input Undervoltage-Lockout Threshold Voltage		0.8	1.2	1.6	V	
Quiescent Supply Current	Charge pump enabled, no load, 3/5 = GND	$T_A = +25^\circ\text{C}$	45	100	μA	
		$T_A = -40^\circ\text{C}$ to $+85^\circ\text{C}$		150		
	Charge pump disabled, no load, 3/5 = IN		3	10		
Shutdown Supply Current	$V_{\text{IN}} = 3.6\text{V}$, $\overline{\text{SHDN}} = \text{GND}$		0.1	5	μA	
OUT Output Voltage	$V_{\text{IN}} = 2.7\text{V}$ to 4.2V , load = 0 to 12mA	MAX1686	4.55	4.75	5.25	V
		MAX1686H	4.75	5.00	5.25	
	3/5 = IN		V_{IN}			
IN-to-OUT Switch On-Resistance	$V_{3/5} = V_{\text{IN}} = 3.0\text{V}$		2.5	5	Ω	
OUT Discharge Switch On-Resistance	3/5 = GND or IN, $\overline{\text{SHDN}} = \text{GND}$		80	200	Ω	
OUT Short-Circuit Current	3/5 = GND or IN	20	100	200	mA	
Logic Input Low Voltage	$\overline{\text{SHDN}}$, 3/5		$0.5 \cdot V_{\text{IN}}$	$0.3 \cdot V_{\text{IN}}$	V	
Logic Input High Voltage	$\overline{\text{SHDN}}$, 3/5	$0.7 \cdot V_{\text{IN}}$	$0.5 \cdot V_{\text{IN}}$		V	
Logic Input Leakage Current	$\overline{\text{SHDN}}$, 3/5 = GND or IN		0.1	1	μA	
Charge-Pump Frequency	$T_A = +25^\circ\text{C}$	800	1000	1200	kHz	
	$T_A = -40^\circ\text{C}$ to $+85^\circ\text{C}$	700		1300		

Note 1: Electrical specifications are measured by pulse testing and are guaranteed for a junction temperature within the operating temperature range, unless otherwise noted. Limits are 100% production tested at $T_A = +25^\circ\text{C}$. Limits over the entire operating temperature range are guaranteed through correlation using Statistical Quality Control (SQC) methods and are not production tested.

3V to 5V Regulating Charge Pumps for SIM Cards

Typical Operating Characteristics

(See Typical Operating Circuit, $C_{IN} = 0.47\mu\text{F}$, $C_X = 0.22\mu\text{F}$, $C_{OUT} = 10\mu\text{F}$, $V_{IN} = 3.3\text{V}$, $T_A = +25^\circ\text{C}$, unless otherwise noted.)

MAX1686/MAX1686H

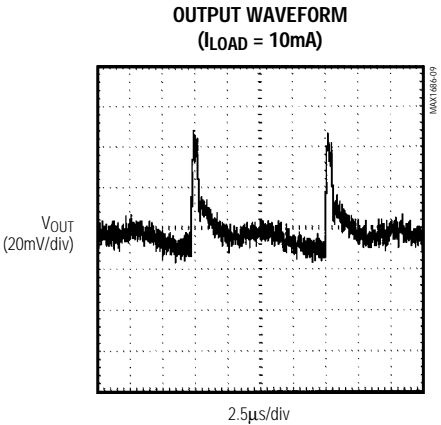
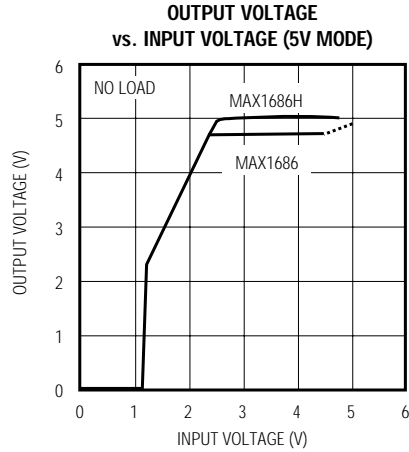
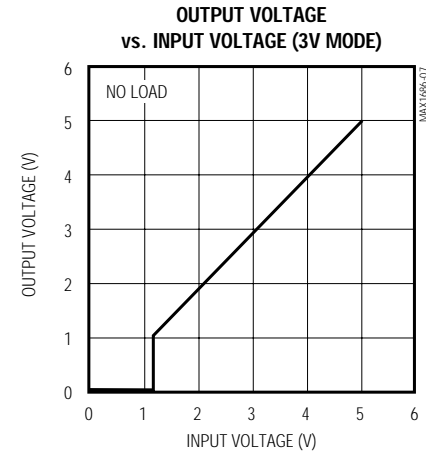
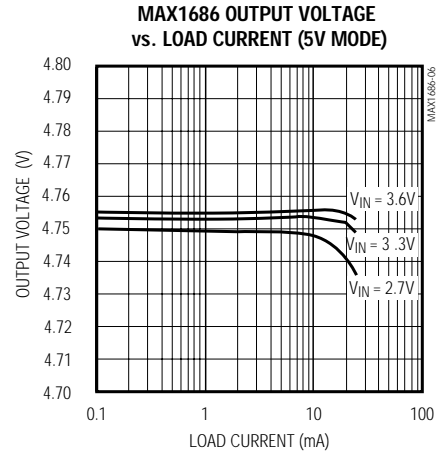
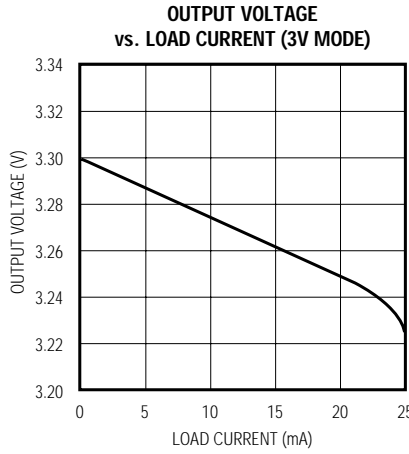
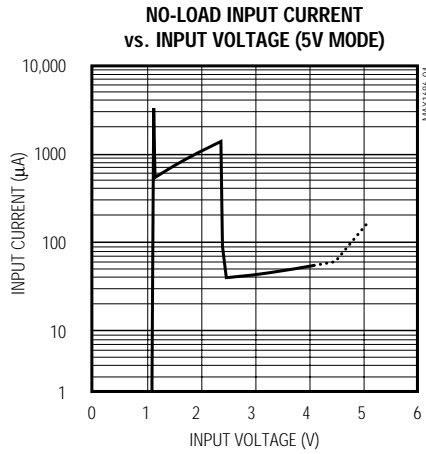
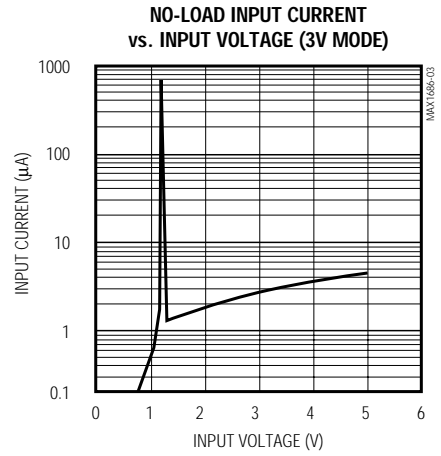
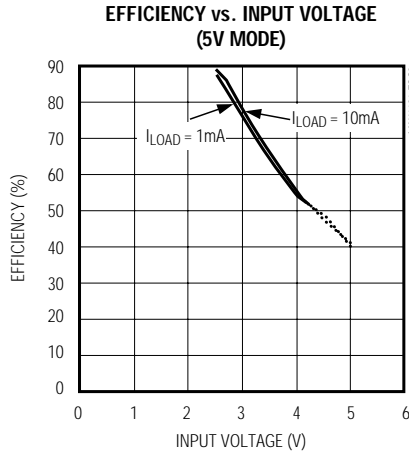
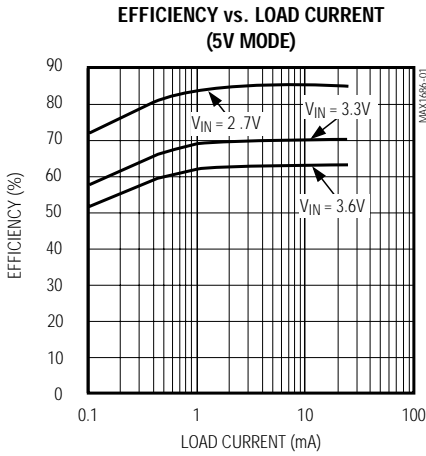

5V MODE, AC COUPLED,
 $C_{OUT} = 10\mu\text{F} \parallel 0.1\mu\text{F}$

3V to 5V Regulating Charge Pumps for SIM Cards

Typical Operating Characteristics (continued)

(See Typical Operating Circuit, $C_{IN} = 0.47\mu\text{F}$, $C_X = 0.22\mu\text{F}$, $C_{OUT} = 10\mu\text{F}$, $V_{IN} = 3.3\text{V}$, $T_A = +25^\circ\text{C}$, unless otherwise noted.)

OUTPUT WAVEFORM
($I_{LOAD} = 1\text{mA}$)

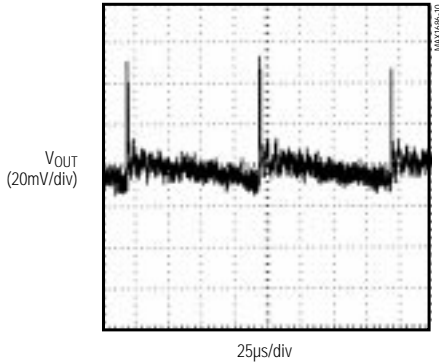

5V MODE, AC COUPLED,
 $C_{OUT} = 10\mu\text{F} \parallel 0.1\mu\text{F}$

LINE-TRANSIENT RESPONSE

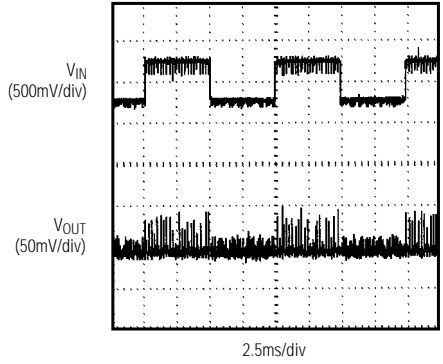

$V_{IN} = 2.8\text{V to } 3.3\text{V}$, $I_{LOAD} = 10\text{mA}$, 5V MODE,
AC COUPLED

LOAD-TRANSIENT RESPONSE

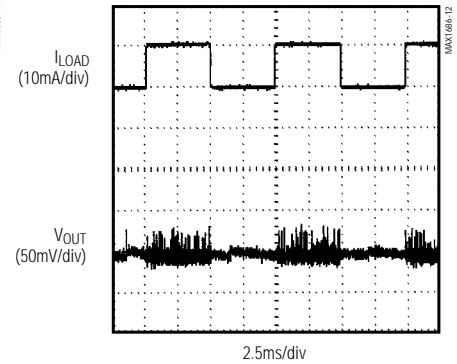

$I_{LOAD} = 0 \text{ TO } 10\text{mA}$, 5V MODE, AC COUPLED

START-UP WAVEFORM
(3V MODE, $R_L = 500\Omega$)

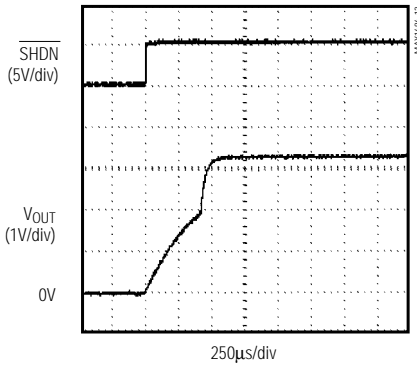

START-UP WAVEFORM
(5V MODE, $R_L = 500\Omega$)

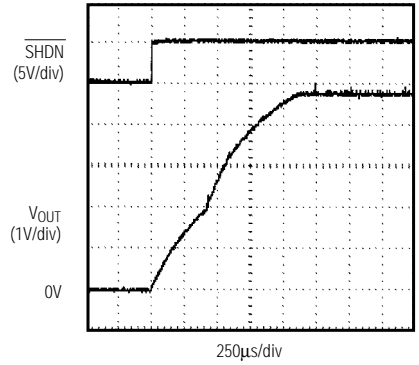

3V MODE TO 5V MODE
WAVEFORM ($R_L = 500\Omega$)

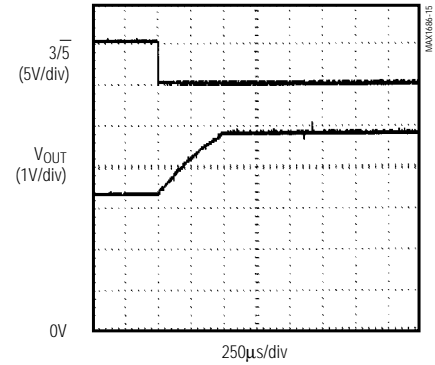

SHUTDOWN WAVEFORM
(3V MODE, NO LOAD)

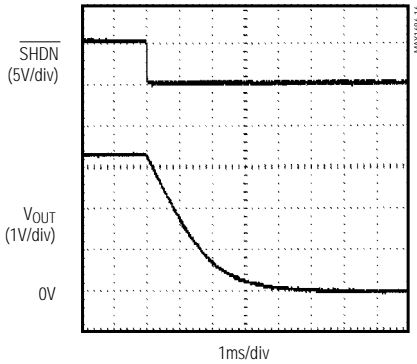

$R_L = 500\Omega$

SHUTDOWN WAVEFORM
(5V MODE, NO LOAD)

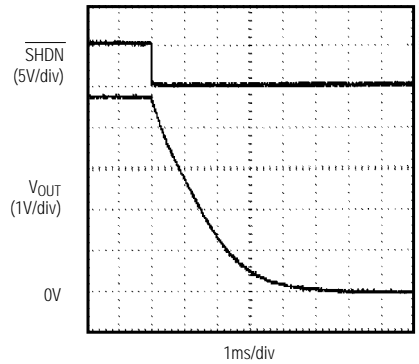

5V MODE TO 3V MODE
WAVEFORM (NO LOAD)

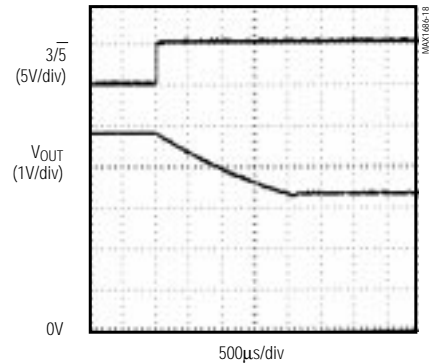

3V to 5V Regulating Charge Pumps for SIM Cards

Pin Description

MAX1686/MAX1686H

PIN	NAME	FUNCTION
1	$3/5$	3V/5V Select Input. When low, the output is regulated at 4.75V for MAX1686, 5.00V for MAX1686H. When high, the output is shorted to the input.
2	$\overline{\text{SHDN}}$	Active-Low Shutdown Input. $\overline{\text{SHDN}} = \text{GND}$ is off. Output is actively pulled low in shutdown.
3	IN	Supply Input Pin. Can range from 2.7V to 4.2V. Bypass to ground with a ceramic capacitor.
4	GND	Ground Pin
5	PGND	Power Ground. Connect to GND through a short trace.
6	CXN	Negative Terminal of the Charge-Pump Transfer Capacitor
7	CXP	Positive Terminal of the Charge-Pump Transfer Capacitor
8	OUT	Power Output. Bypass to GND with an output filter capacitor.

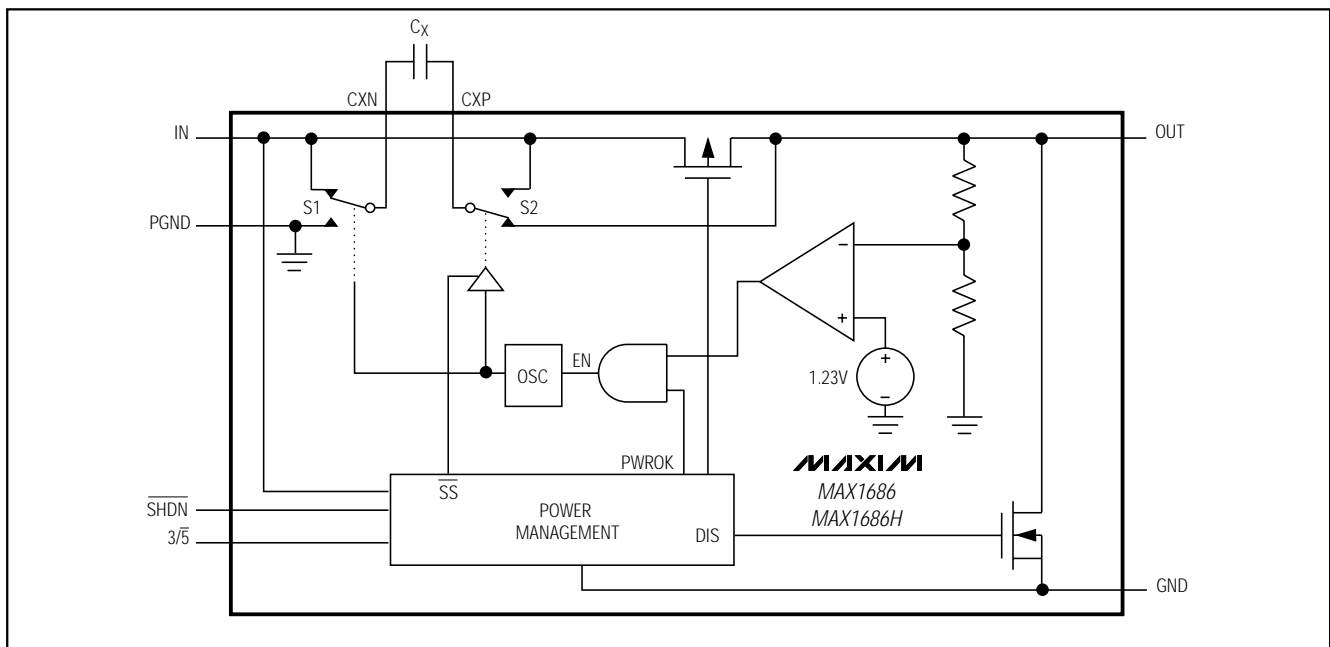

Figure 1. Functional Diagram

Detailed Description

The MAX1686/MAX1686H charge pumps provide two modes of operation: 3V mode or 5V mode. The devices consist of an error amplifier, a 1.23V bandgap reference, an internal resistive feedback network, a 1MHz oscillator, high-current MOSFET drivers and switches, and a power-management block as shown in the *Functional Diagram* (Figure 1). In 3V mode ($3/5 = \text{IN}$), the input is connected to the output through a 2.5Ω switch. In 5V mode ($3/5 = \text{GND}$), the MAX1686's output

voltage is regulated at 4.75V (5.00V for the MAX1686H) with a 2.7V to 4.2V input and can deliver more than 12mA of load current.

Designed specifically for compact applications, these regulators require only three small external capacitors. The Skip Mode control scheme provides high efficiency over a wide output current range. The devices offer a shutdown feature which actively discharges the output to ground and reduces the supply current to less than

3V to 5V Regulating Charge Pumps for SIM Cards

1 μ A. Other features include soft-start, undervoltage lockout, and short-circuit protection.

Charge-Pump Control

Figure 2 shows an idealized, unregulated charge-pump voltage doubler. The oscillator runs at a 50% duty cycle. During one half of the period, the transfer capacitor (C_X) charges to the input voltage. During the other half, the doubler stacks the voltage across C_X and the input voltage, and transfers the sum of the two voltages to the output filter capacitor (C_{OUT}). The MAX1686 uses Skip Mode control to regulate its output voltage and to achieve good efficiency over a large output current range. When the comparator detects that the output voltage is too low, the 1MHz oscillator is enabled and C_X is switched. When the output voltage is above regulation, the oscillator is disabled and C_X is connected at the input.

Soft-Start

In the 5V mode ($3/\bar{5} = \text{GND}$), the start-up current is limited by the soft-start control to typically 200mA, independent of the load. Until the output voltage reaches $V_{IN} / 2$, the input is connected to the output through a 50 Ω series P-channel MOSFET and the charge pump is disabled. For $V_{IN} / 2 < V_{OUT} < 4.75\text{V}$ (5.00V for MAX1686H) and for a maximum of 2ms the charge pump is active, but R_{ON} of the switch S2 is limited to 50 Ω . This limits typical current surges associated with charge pumps at start-up. When soft-start is complete, $V_{OUT} > 4.75\text{V}$ (5.00V for MAX1686H) or 2ms (whichever occurs first), switch S2's on-resistance is decreased to minimize losses.

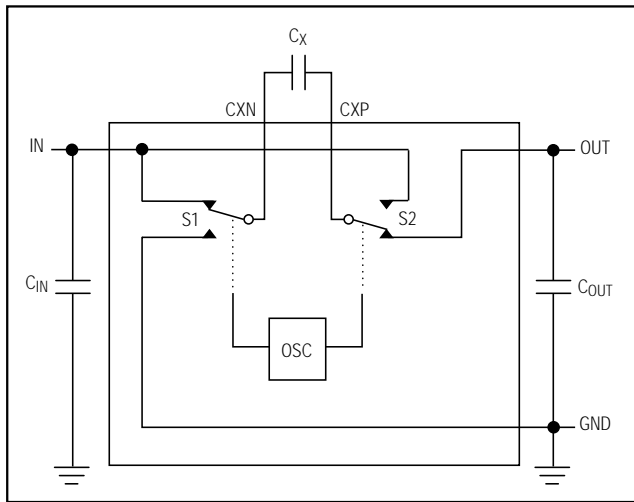

Figure 2. Unregulated Voltage Doubler

In 3V mode ($3/\bar{5} = \text{IN}$), the start-up current is limited by the 50 Ω series P-channel MOSFET connected between IN and OUT until the output voltage reaches $V_{IN} / 2$. For $V_{OUT} > V_{IN} / 2$, R_{ON} is reduced to 2.5 Ω .

With a 500 Ω load the device turns on in less than 1.5ms (see *Typical Operating Characteristics* for graphs of start-up waveforms).

Shutdown Mode

Driving $\overline{\text{SHDN}}$ low places the device in shutdown mode, which disables the oscillator, the control logic, and the reference. Placing the device in shutdown mode reduces the no-load supply current to less than 1 μ A; the output is actively discharged through the internal N-channel FET and disconnected from the input. In normal operation, $\overline{\text{SHDN}}$ is driven high or connected to IN.

Applications Information

Capacitor Selection

The MAX1686 requires only three external capacitors. The capacitor values are closely linked to the output current capability, noise, and switching frequency. The 1MHz oscillator frequency minimizes capacitor size compared to lower-frequency charge pumps.

Generally, the transfer capacitor (C_X) will be the smallest, the input capacitor (C_{IN}) will be twice the size of C_X , and the output capacitor (C_{OUT}) can be from 10 to 50 times C_X . The suggested capacitor values are $C_{IN} = 0.1\mu\text{F}$, $C_X = 0.047\mu\text{F}$, and $C_{OUT} = 2.2\mu\text{F}$ as shown in Figure 3. For input voltages as low as 2.7V, the following values are recommended: $C_{IN} = 0.47\mu\text{F}$, $C_X = 0.22\mu\text{F}$, and $C_{OUT} = 10\mu\text{F}$. Table 1 lists the perfor-

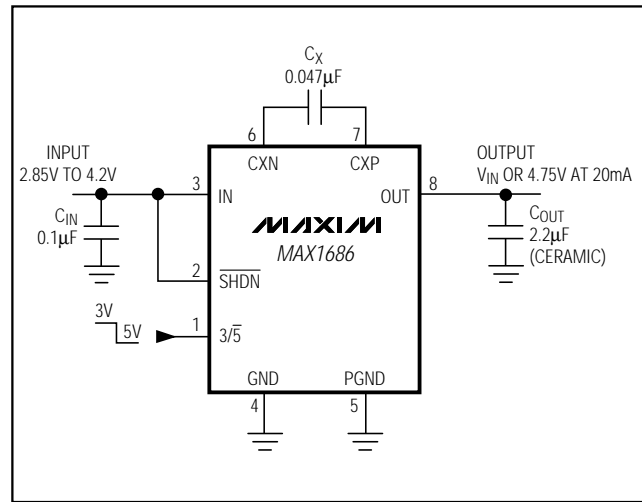

Figure 3. Standard Application Circuit

3V to 5V Regulating Charge Pumps for SIM Cards

MAX1686/MAX1686H

mance with different input voltages and an additional small 0.1 μ F capacitor at the output. The extra 0.1 μ F capacitor improves start-up capability under full load and reduces output ripple for high input voltages. Table 2 lists the recommended capacitor manufacturers. Low-ESR capacitors, such as surface-mount ceramics, decrease noise and give the best efficiency. Capacitance and ESR variation over temperature need to be taken into consideration for best performance in applications with large operating temperature ranges.

For applications where the minimum input voltage is 3V or greater, the flying capacitor, C_x, can be decreased to 0.1 μ F. This provides two benefits: the inrush surge current at start-up is reduced, and the output ripple voltage (especially at high input voltages) is also reduced.

Table 1. Ripple and Efficiency vs. Input Voltage and Load Current

INPUT VOLTAGE (V)	LOAD CURRENT (mA)	V _{OUT} RIPPLE (mV)	EFFICIENCY (%)
2.7	1	30	84.3
2.7	10	30	86.2
3.3	1	60	69.5
3.3	10	60	70.5
3.6	1	80	63.2
3.6	10	80	63.8
4.2	1	120	52.3
4.2	10	120	52.1

Layout Considerations
High switching frequencies and large peak currents make PC board layout an important part of design. All capacitors should be soldered close to the IC. Connect ground and power ground through a short, low-impedance trace. Keep the extra copper on the board and integrate it into ground as a pseudo-ground plane. On multilayer boards, route the star ground using component-side copper fill, then connect it to the internal ground plane using vias. Ensure that the load is connected directly across the output filter capacitor.

Table 2. Recommended Surface-Mount Capacitor Manufacturers

VALUE (μ F)	DESCRIPTION	MFR.	PHONE NUMBER
1 to 47	595D-series tantalum	Sprague	(603) 224-1961
4.7 to 47	TPS-series tantalum	AVX	(803) 946-0690
1 to 10	267 series tantalum	Matsuo	(714) 969-2491
0.047 to 2.2	X7R ceramic	TDK	(847) 390-4373
		AVX	(803) 946-0690

Chip Information

TRANSISTOR COUNT: 840

3V to 5V Regulating Charge Pumps for SIM Cards

Package Information

	INCHES		MILLIMETERS		JEDEC			
	MIN	MAX	MIN	MAX	MIN	MAX	MIN	MAX
A	0.037	0.043	0.94	1.10	---	0.043	---	1.10
A1	0.002	0.006	0.05	0.15	0.002	0.006	0.05	0.15
B	0.010	0.014	0.25	0.36	0.010	0.016	0.25	0.40
C	0.005	0.007	0.13	0.18	0.005	0.009	0.13	0.23
D	0.116	0.120	2.95	3.05	0.114	0.122	2.9	3.1
e	0.0256 BSC		0.65 BSC		0.0256 BSC		0.64 BSC	
E	0.116	0.120	2.95	3.05	0.114	0.122	2.9	3.1
H	0.188	0.198	4.78	5.03	0.193 BSC		4.9 BSC	
L	0.016	0.026	0.41	0.66	0.016	0.027	0.40	0.70
α	0°	6°	0°	6°	0°	6°	0°	6°

NOTES:

- D & E DO NOT INCLUDE MOLD FLASH.
- MOLD FLASH OR PROTRUSIONS NOT TO EXCEED .15mm(.006").
- CONTROLLING DIMENSION: MILLIMETERS.
- MEETS JEDEC MO-187.

8LUMAXD.EPS

MAXIM		
<small>PROPRIETARY INFORMATION</small>		
<small>TITLE:</small> 8L uMAX PACKAGE OUTLINE DWG.		
<small>APPROVAL</small>	<small>DOCUMENT CONTROL NO.</small> 21-0036	<small>REV</small> F 1/1

Maxim cannot assume responsibility for use of any circuitry other than circuitry entirely embodied in a Maxim product. No circuit patent licenses are implied. Maxim reserves the right to change the circuitry and specifications without notice at any time.

8 Maxim Integrated Products, 120 San Gabriel Drive, Sunnyvale, CA 94086 408-737-7600

Looking for pricing, stock, or lifecycle information?

Click below to explore more details on WIN SOURCE:

 [View MAX1686EUA+T on WIN SOURCE](#)

 [Maxim Integrated](#) Information

Optimize Your Supply Chain with WIN SOURCE Solutions

-  Global Sourcing Solution
-  Obsolete Management
-  Cost Control Management
-  Shortage Management
-  Alternative Solution
-  Excess Inventory Management