



**THE DATASHEET OF  
MAX1688ESA+**





# Step-Up DC-DC Converters with Precise, Adaptive Current Limit for GSM

## General Description

The MAX1687/MAX1688 step-up DC-DC converters deliver up to 2W from a single Li-Ion or three NiMH cells. The devices are ideal for burst-load applications such as GSM cell phones and wireless LANs, where the RF power amplifiers require short, high current bursts. The MAX1687/MAX1688 reduce battery surge current by slowly charging a reservoir capacitor, which supplies the necessary peak energy for the load current burst. As a result, the peak battery current is limited, thus maximizing battery life and minimizing battery voltage sag and transient dips.

An internal synchronous rectifier provides over 90% conversion efficiency and eliminates the need for an external Schottky diode. A logic shutdown mode reduces the shutdown current to only 3 $\mu$ A. The devices can be disabled during current bursts (RF transmit mode) to eliminate switching noise.

The switching frequency of the MAX1687/MAX1688, controlled by the selected inductor, can exceed 1MHz. Two external resistors set the output voltage from 1.25V to 6V. The MAX1687 controls peak battery current, while the MAX1688 features a more advanced, adaptive constant-recharge-time algorithm that maximizes battery life. The MAX1687/MAX1688 are available in thin 16-pin TSSOP (1.1mm max height) or standard 8-pin SO packages.

## Applications

GSM Phones  
Wireless Handsets  
PC Cards (PCMCIA)

## Pin Configurations

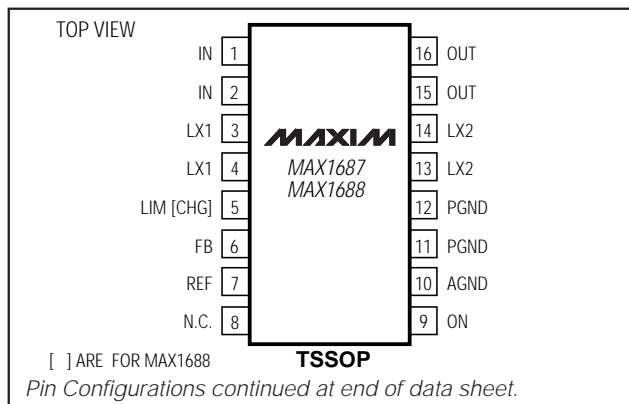

## Features

- ♦ Low 450mA Peak Battery Current Provides 2A, 5V GSM Burst
- ♦ 90% Efficiency
- ♦ Internal Power MOSFETs and Current-Sense Resistor
- ♦ Output Disconnects from Input During Shutdown
- ♦ 3 $\mu$ A Shutdown Current
- ♦ Precise Voltage-Controlled Current Limit (MAX1687)
- ♦ Adaptive Constant-Recharge-Time Capability (MAX1688)
- ♦ 1.25V to 6V Adjustable Output
- ♦ 2.7V to 6V Input Range (1 Li-Ion cell or 3 NiMH cells)
- ♦ Switching Frequency Can Exceed 1MHz
- ♦ Standby Mode Disables DC-DC During Transmission Burst
- ♦ Low Inrush Current at Start-Up

## Ordering Information

PART	TEMP. RANGE	PIN-PACKAGE
MAX1687EUE	-40°C to +85°C	16 TSSOP
MAX1687ESA	-40°C to +85°C	8 SO
MAX1688EUE	-40°C to +85°C	16 TSSOP
MAX1688ESA	-40°C to +85°C	8 SO

## Typical Operating Circuit

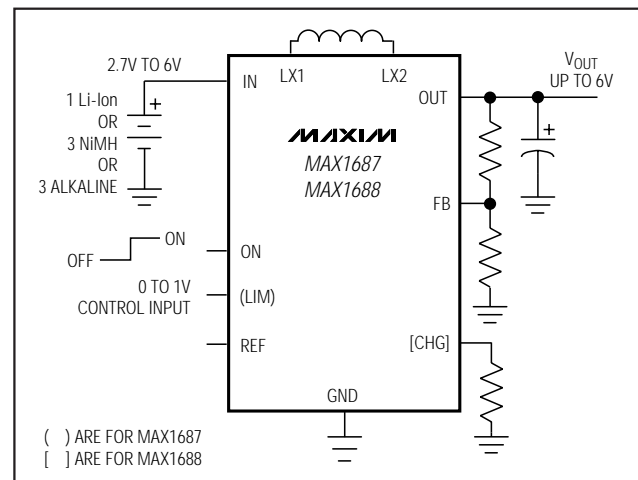

# Step-Up DC-DC Converters with Precise, Adaptive Current Limit for GSM

## ABSOLUTE MAXIMUM RATINGS

IN, ON, LX1, CHG, LIM, FB, OUT, REF to GND	-0.3V to +7V
LX2 to GND	-0.3V to +8V
IN, LX1 Average Current	1A
Continuous Power Dissipation (T <sub>A</sub> = +70°C)	
TSSOP (derate 5.7mW/°C above +70°C)	457mW
SO (derate 5.88mW/°C above +70°C)	471mW

Operating Temperature Range	-40°C to +85°C
Storage Temperature Range	-65°C to +150°C
Lead Temperature (soldering, 10sec)	+300°C

Stresses beyond those listed under "Absolute Maximum Ratings" may cause permanent damage to the device. These are stress ratings only, and functional operation of the device at these or any other conditions beyond those indicated in the operational sections of the specifications is not implied. Exposure to absolute maximum rating conditions for extended periods may affect device reliability.

## ELECTRICAL CHARACTERISTICS

(V<sub>IN</sub> = V<sub>ON</sub> = +3V, V<sub>LIM</sub> = 1V (MAX1687), V<sub>CHG</sub> = 1V (MAX1688), V<sub>FB</sub> = 1.5V, V<sub>OUT</sub> = 6V, T<sub>A</sub> = 0°C to +85°C, unless otherwise noted. Typical values are at T<sub>A</sub> = +25°C.)

PARAMETER	SYMBOL	CONDITIONS	MIN	TYP	MAX	UNITS
Input Voltage Range			2.7		6	V
Input Undervoltage Lockout		IN rising, 1% hysteresis	2.4	2.5	2.6	V
Output Voltage Range			V <sub>REF</sub>		6	V
Input Supply Current		V <sub>FB</sub> = 1.5V		2	4	mA
		Shutdown, V <sub>IN</sub> = 4.2V, LX2 connected to LX1, V <sub>OUT</sub> = 0, ON = GND		3	10	μA
Shutdown Delay	t <sub>DELAY</sub>		0.7	1.2	1.8	ms
Reference Voltage	V <sub>REF</sub>	I <sub>REF</sub> = 0 to 10μA	1.225	1.25	1.275	V
FB Set Voltage		V <sub>FB</sub> rising, 2% hysteresis	1.212	1.250	1.288	V
FB Transconductance	g <sub>mFB</sub>	V <sub>FB</sub> = 1.125V, V <sub>OUT</sub> = 3V (MAX1688)	0.18	0.2	0.22	mmho
I <sub>CHG</sub> Source Current		V <sub>FB</sub> = 0, V <sub>OUT</sub> = 3V (MAX1688)	60	110		μA
Peak Current	I <sub>PEAK</sub>	V <sub>LIM</sub> = V <sub>CHG</sub> = 1V	0.744	0.8	0.856	A
		V <sub>LIM</sub> = V <sub>CHG</sub> = 0.65V	0.46	0.5	0.54	
Ripple Current	I <sub>RIPPLE</sub>	V <sub>LIM</sub> = V <sub>CHG</sub> = 1V	170	200	230	mA
Sense Resistor	R <sub>SENSE</sub>			0.1	0.18	Ω
ON Input Low Voltage	V <sub>IL</sub>	V <sub>IN</sub> = 2.7V			0.6	V
ON Input High Voltage	V <sub>IH</sub>	V <sub>IN</sub> = 6V	1.8			V
		V <sub>IN</sub> = 4.2V	1.5			
Input Current	I <sub>FB</sub>	V <sub>FB</sub> = 1.5V		0.05	0.2	μA
	I <sub>ON</sub>	V <sub>ON</sub> = 0 or 3V		0.02	0.1	
	I <sub>LIM</sub>	V <sub>LIM</sub> = 1V	T <sub>A</sub> = +25°C		0.02	
T <sub>A</sub> = 0°C to +85°C					2	
N-Channel On-Resistance		V <sub>IN</sub> = 2.7V		0.4	0.8	Ω
P-Channel On-Resistance		V <sub>IN</sub> = 2.7V		0.3	0.7	Ω
Precharge On-Resistance		V <sub>IN</sub> = 4V, V <sub>FB</sub> = 0, V <sub>OUT</sub> = 0		30	70	Ω
LX2 Leakage Current		V <sub>IN</sub> = V <sub>LX2</sub> = 6V, V <sub>OUT</sub> = V <sub>ON</sub> = 0		0.05	10	μA

# Step-Up DC-DC Converters with Precise, Adaptive Current Limit for GSM

MAX1687/MAX1688

## ELECTRICAL CHARACTERISTICS

( $V_{IN} = V_{ON} = +3V$ ,  $V_{LIM} = 1V$  (MAX1687),  $V_{CHG} = 1V$  (MAX1688),  $V_{FB} = 1.5V$ ,  $V_{OUT} = 6V$ ,  $T_A = -40^{\circ}C$  to  $+85^{\circ}C$ , unless otherwise noted.) (Note 1)

PARAMETER	SYMBOL	CONDITIONS	MIN	TYP	MAX	UNITS
Input Voltage Range			2.7		6	V
Input Undervoltage Lockout		IN rising, 1% hysteresis	2.35		2.65	V
Output Voltage Range			$V_{REF}$		6	V
Input Supply Current	$I_{IN}$	$V_{FB} = 1.5V$			5	mA
	$I_{SHDN}$	Shutdown $V_{IN} = 4.2V$ , LX2 connected to LX1, $V_{OUT} = 0$ , ON = GND			10	$\mu A$
Shutdown Delay	$T_{DELAY}$		0.6		2	ms
Reference Voltage	$V_{REF}$	$I_{REF} = 0$ to $10\mu A$	1.212		1.288	V
FB Set Voltage		FB rising, 2% hysteresis	1.20		1.30	V
FB Transconductance	$gm_{FB}$	$V_{FB} = 1.125V$ , $V_{OUT} = 3V$ (MAX1688)	0.16		0.24	mmho
Peak Current	$I_{PEAK}$	$V_{LIM} = V_{CHG} = 1V$	0.73		0.90	A
		$V_{LIM} = V_{CHG} = 0.65V$	0.44		0.57	
Ripple Current	$I_{RIPPLE}$	$V_{LIM} = V_{CHG} = 1V$	145		240	mA
Sense Resistor	$R_{SENSE}$				0.18	$\Omega$
ON Input Low Voltage	$V_{IL}$	$V_{IN} = 2.7V$			0.6	V
ON Input High Voltage	$V_{IH}$	$V_{IN} = 6V$	1.8			V
		$V_{IN} = 4.2V$	1.5			
N-Channel On-Resistance		$V_{IN} = 2.7V$			0.8	$\Omega$
P-Channel On-Resistance		$V_{IN} = 2.7V$			0.7	$\Omega$
Precharge On-Resistance		$V_{IN} = 4V$ , $V_{FB} = 0$ , $V_{OUT} = 0$			70	$\Omega$

**Note 1:** Specifications to  $-40^{\circ}C$  are guaranteed by design, not production tested.

## Typical Operating Characteristics

( $V_{IN} = +3.3V$ ,  $V_{OUT} = 5V$ ,  $V_{LIM} = 1V$ , Figures 6b and 7,  $T_A = +25^{\circ}C$ , unless otherwise noted.)

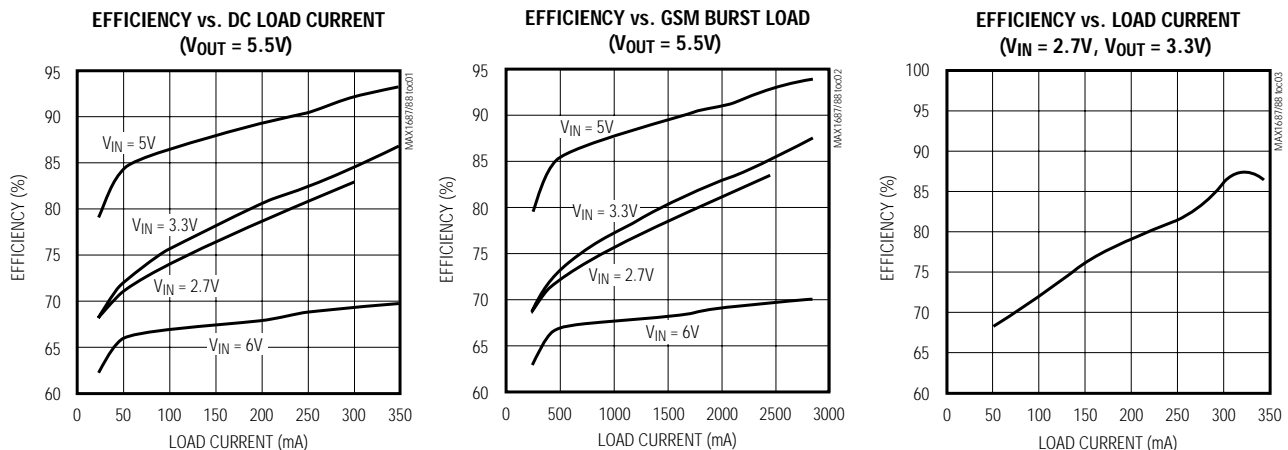

# Step-Up DC-DC Converters with Precise, Adaptive Current Limit for GSM

## Typical Operating Characteristics (continued)

( $V_{IN} = +3.3V$ ,  $V_{OUT} = 5V$ ,  $V_{LIM} = 1V$ , Figures 6b and 7,  $T_A = +25^\circ C$ , unless otherwise noted.)

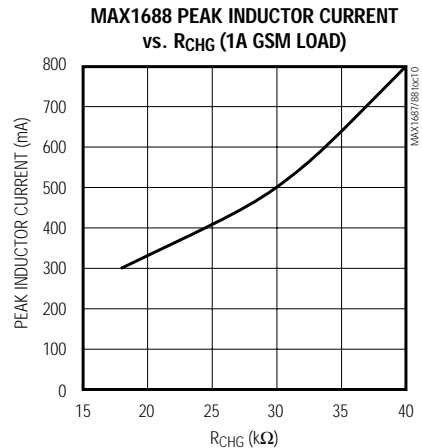
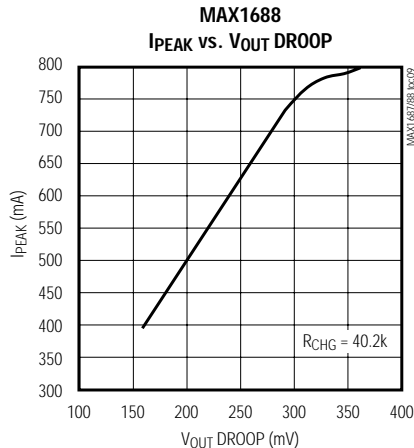
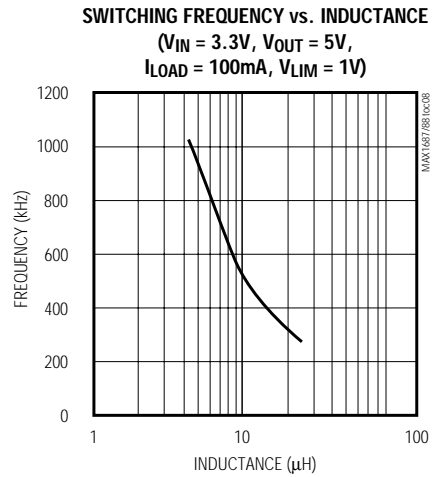
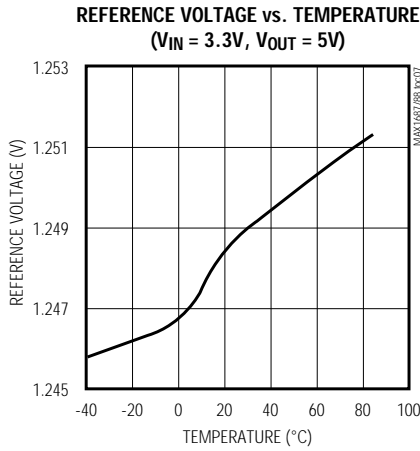
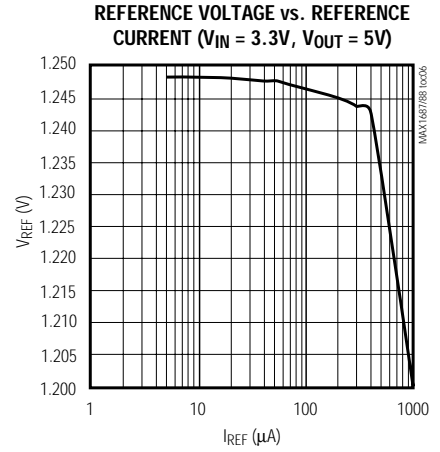
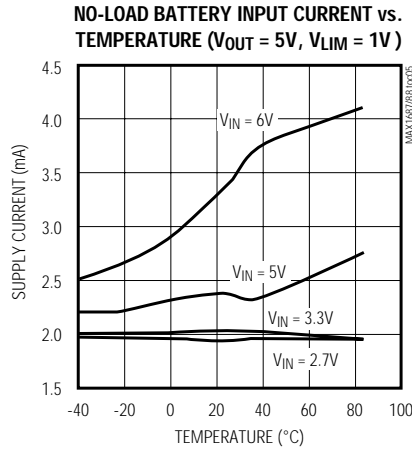
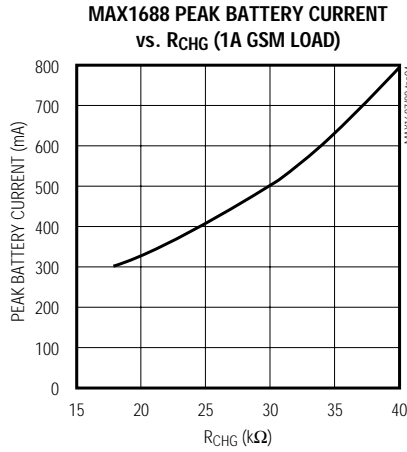

# Step-Up DC-DC Converters with Precise, Adaptive Current Limit for GSM

## Typical Operating Characteristics (continued)

( $V_{IN} = +3.3V$ ,  $V_{OUT} = 5V$ ,  $V_{LIM} = 1V$ , Figures 6b and 7,  $T_A = +25^\circ C$ , unless otherwise noted.)

MAX1687/MAX1688

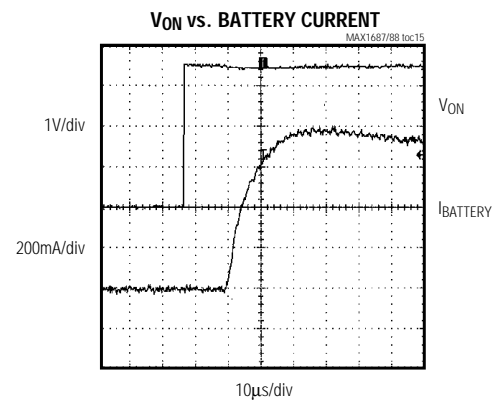
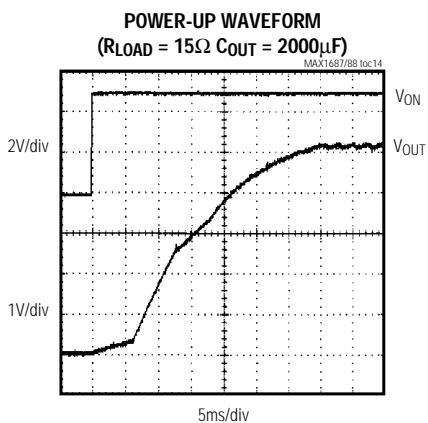
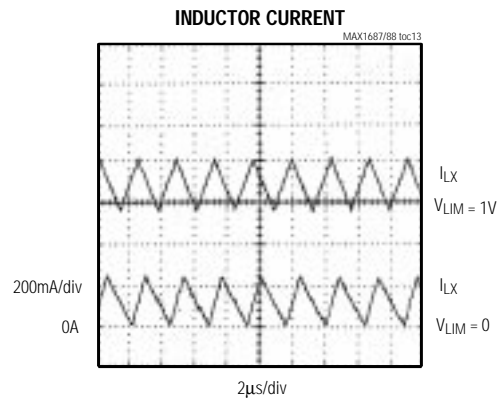
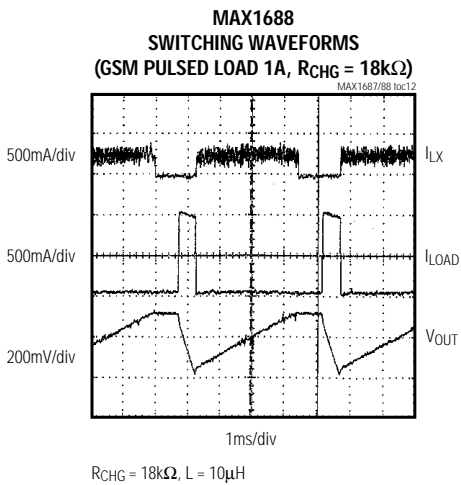
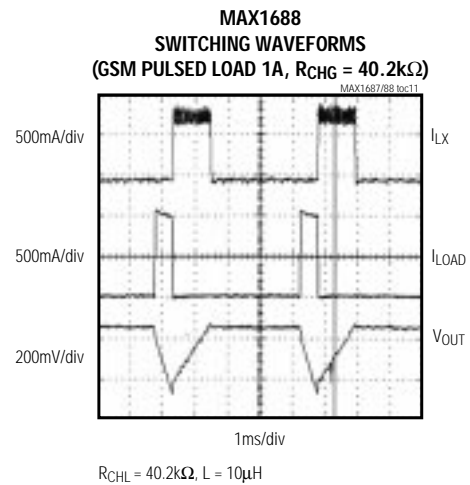
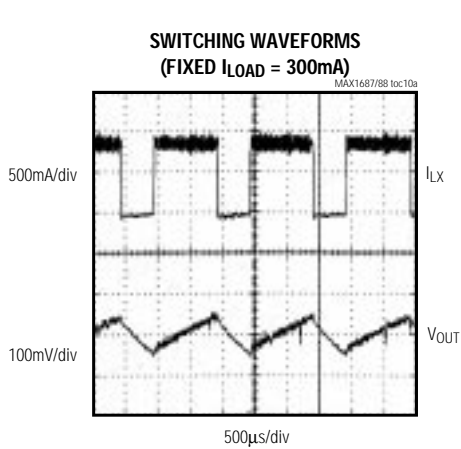

# Step-Up DC-DC Converters with Precise, Adaptive Current Limit for GSM

## Pin Description

PIN				NAME	FUNCTION
MAX1687		MAX1688			
SO	TSSOP	SO	TSSOP		
1	1, 2	1	1, 2	IN	Supply Voltage Input. Connect Battery to IN. Bypass to GND with a 47 $\mu$ F minimum capacitor.
2	3, 4	2	3, 4	LX1	Internal Current-Sense Resistor Output. Connect the inductor between LX1 and LX2.
3	5	—	—	LIM	Voltage-Controlled Current-Limit Adjust Input. Apply a voltage between 0 and 1V to vary the current limit. LIM is internally clamped to 1.25V.
—	—	3	5	CHG	Constant-Recharge-Time Input. Set the recharge time of the output reservoir capacitor by connecting a resistor from CHG to GND (see <i>Applications Information</i> section).
4	6	4	6	FB	Feedback Input. Connect a resistor-divider from OUT to GND to set the output voltage. FB regulates to a nominal 1.25V.
—	7	—	7	REF	Reference Voltage Output. 1.25V nominal.
—	8	—	8	N.C.	No Connection. Not internally connected.
5	9	5	9	ON	Logic ON/OFF Input. When ON is high, the device operates in normal mode. When ON goes low, the device goes into standby mode. If ON remains low for greater than 1.2ms, the device shuts down (see <i>Standby/Shutdown</i> section). The supply current falls to 3 $\mu$ A in shutdown mode.
6	—	6	—	GND	Ground
—	10	—	10	AGND	Analog Ground
—	11, 12	—	11, 12	PGND	Power Ground
7	13, 14	7	13, 14	LX2	N-Channel and P-Channel MOSFET Drain
8	15, 16	8	15, 16	OUT	Output

### Detailed Description

The MAX1687 and MAX1688 ICs supply power amplifiers in GSM applications where limited input current surge is desirable. For example, GSM systems require high-power, 12% duty-cycle RF bursts. Synchronizing the MAX1687/MAX1688 to enter standby mode during these RF bursts eliminates battery surge current and minimizes switching noise to the power amplifier. In standby mode, the charged output reservoir capacitor delivers power to the power amplifier. Between each burst, the DC-DC converter switches on to charge the output capacitor. To improve efficiency and reduce peak battery current, the MAX1687/MAX1688 provide a volt-

age-controlled current limit. The MAX1688 is a MAX1687 with added self-regulating circuitry that recharges the reservoir capacitor in a fixed time (Figure 1).

### Start-Up Sequence

In a conventional DC-DC converter, when high current is required by the load, the battery voltage droops due to battery series resistance. This may cause other circuitry that depends on the battery to malfunction or be reset. The MAX1687/MAX1688 prevent battery voltage droop by charging the reservoir capacitor during system off-time and isolate the battery from the output during high current demand. The MAX1687/MAX1688 are gentle to the battery during initial power-up, as well.

# Step-Up DC-DC Converters with Precise, Adaptive Current Limit for GSM

MAX1687/MAX1688

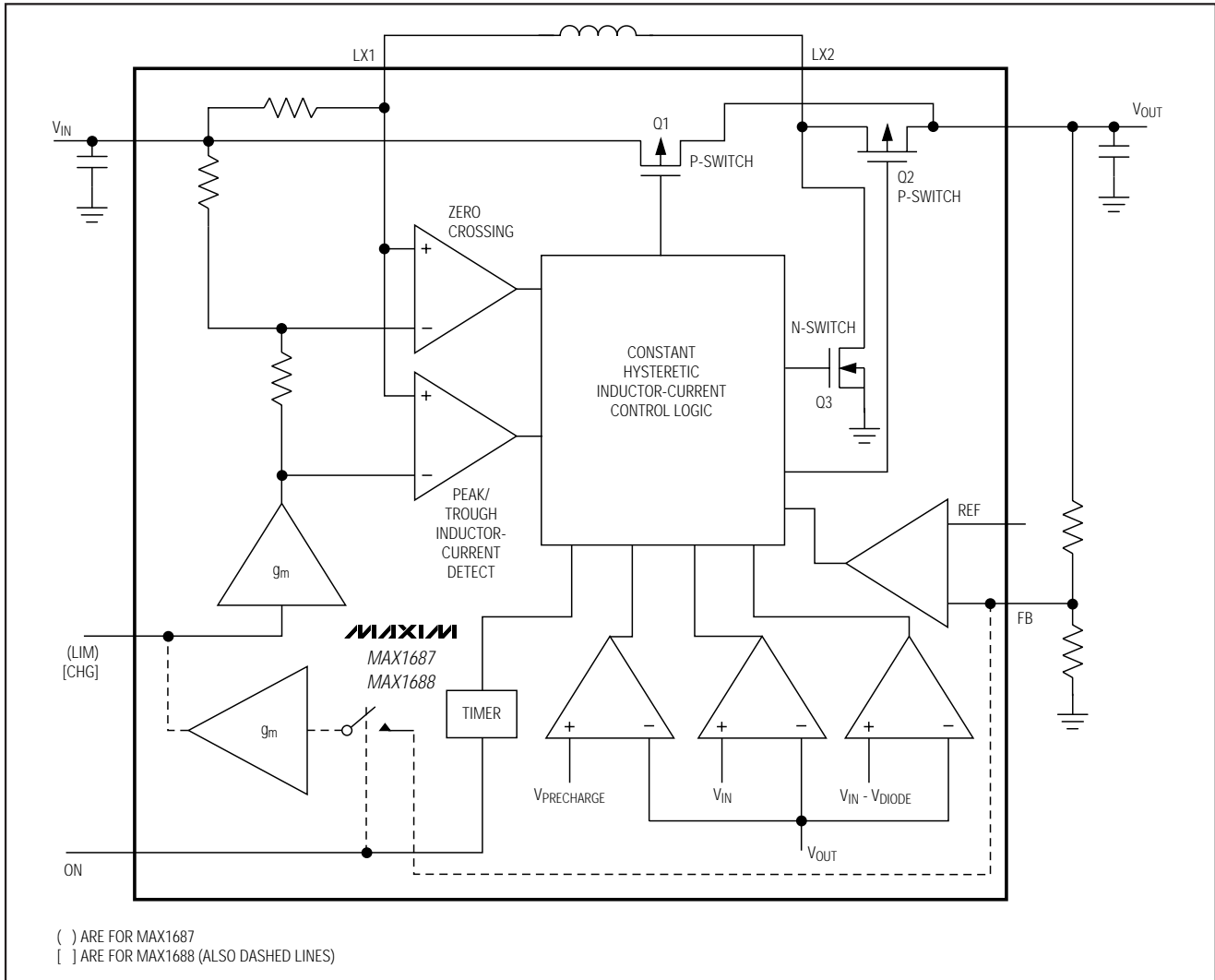

Figure 1. Functional Diagram

When starting up, the MAX1687/MAX1688 employ four successive phases of operation to reduce the inrush of current from the battery. These phases are Linear Regulator Mode, Pseudo Buck Mode, Pseudo Boost Mode, and Boost Mode. In Linear Regulator Mode, the output connects to the input through a  $30\Omega$  precharge PMOS device (Figure 1, Q1). The transition from Linear Mode to Pseudo Buck Mode occurs when  $V_{OUT} = V_{IN} - 3V$ . The transition from Pseudo Buck Mode to Pseudo Boost Mode occurs when  $V_{OUT} = V_{IN} - 0.7V$ . The transition from Pseudo Boost Mode to Boost Mode occurs when  $V_{OUT} > V_{IN}$ . Due to these mode changes, the battery input current remains relatively constant, and  $V_{OUT}$  changes slope as it rises.

**Hysteretic Inductor-Current Control**  
Logic circuits in the MAX1687/MAX1688 control the inductor ripple current to typically 200mA (Figure 2). The voltage at LIM (CHG) programs  $I_{PEAK}$ . The inductor current oscillates between  $I_{PEAK} - 200mA$  and  $I_{PEAK}$ .

**Standby/Shutdown**  
When ON goes low, the device enters Standby Mode, inductor current ramps to zero, and the output disconnects from the input. If ON remains low for greater than 1.2ms (typ), the device shuts down and quiescent current drops to  $3\mu A$  (typ).

# Step-Up DC-DC Converters with Precise, Adaptive Current Limit for GSM

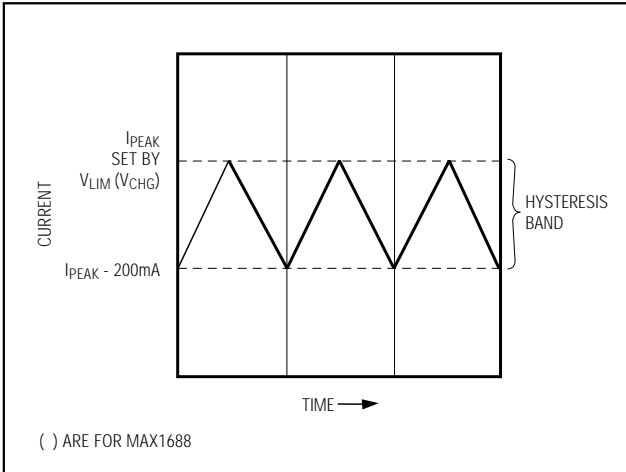

Figure 2. Hysteretic Inductor Current

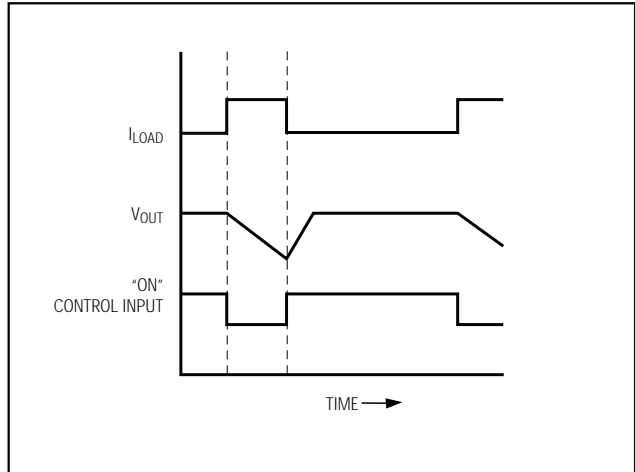

Figure 4. Timing Diagram of "ON"

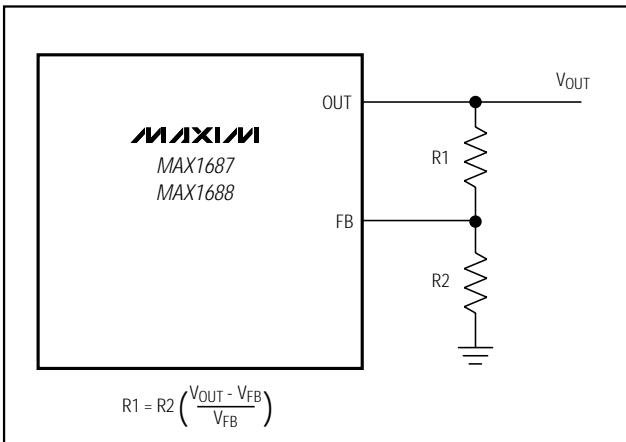

Figure 3. Setting the Output Voltage

### Synchronized ON Pin

If desired, drive ON low during periods of high current demand to eliminate switching noise from affecting sensitive RF circuitry. During the periods when ON is low, the output reservoir capacitor provides current to the load (Figure 4).

### Buck Capability

Although the IC is not intended for this application, the MAX1687/MAX1688 operate as a buck converter when the input voltage is higher than the output voltage. The MAX1687/MAX1688 are not optimally efficient in this mode (see *Typical Operating Characteristics* for efficiencies at 2.7V, 3.3V, 5V, and 6V input supply voltages).

## Applications Information

### Adjusting the Output Voltage

Adjust the MAX1687/MAX1688 output voltage with two external resistors (Figure 3). Choose R2 to be between 10kΩ to 100kΩ. Calculate R1 as follows:

$$R1 = R2 \cdot (V_{OUT} - V_{FB}) / V_{FB}$$

where  $V_{FB}$  is the feedback threshold voltage, 1.25V nominal.

### Adjusting Current Limit (MAX1687)

The MAX1687 has an adjustable current limit for applications requiring limited supply current, such as PC card sockets or applications with variable burst loads. For single Li-Ion battery cell applications, the high peak current demands of the RF transmitter power amplifier can pull the battery very low as the battery impedance increases toward the end of discharge. The reservoir capacitor at the output supplies power during load-current bursts; this allows for a lower input current limit. With this feature, the life of the Li-Ion battery versus the reservoir capacitor size trade-off can be optimized for each application.

# Step-Up DC-DC Converters with Precise, Adaptive Current Limit for GSM

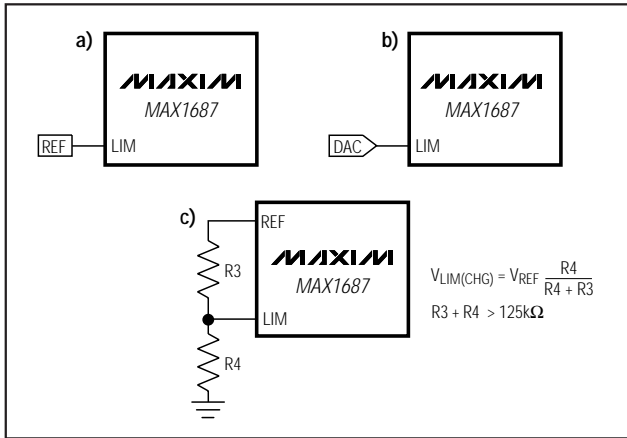

Figure 5. Current-Limit Adjust

To set the current limit, apply a voltage of 0 to 1V at LIM. The current limit is 200mA when  $V_{LIM} = 0$  to 0.25V. Use the following equation to calculate  $I_{LIM}$ :

$$I_{LIM} = V_{LIM} (0.86A/V) - 0.06A$$

where  $V_{LIM} = 0.25V$  to 1V.

$V_{LIM}$  is internally clamped to 1.25V when the voltage applied at  $V_{LIM}$  is above 1.25V. Generate  $V_{LIM}$  by one of three methods: an externally applied voltage, the output of a DAC, or a resistor-divider using  $V_{REF}$  as the supply voltage (TSSOP packages) (Figure 5). Note that REF can supply up to 10 $\mu$ A.

Determine  $V_{LIM}$  as follows:

$$V_{LIM} = (I_{LX}(PEAK) + 0.06A) / 0.86$$

where  $I_{LX}(PEAK) = [(I_{LOAD} \cdot V_{OUT}) / V_{IN}] + 0.1A$  (see the Inductor Current parameter in the *Typical Operating Characteristics*).

### Setting Recharge Time (MAX1688)

The MAX1688 has a recharging feature employing a sample-and-hold, which sets the maximum time to recharge the reservoir capacitor. Synchronize the ON pin to place the converter in standby during each load current burst. At the end of each load current burst, the output voltage is sampled by the MAX1688. This voltage controls the peak inductor current. The greater the difference between the regulated output voltage and the valley of the sag voltage, the higher the peak current. This results in a constant recharge time that compensates for varying output filter capacitor characteristics as well as a varying input voltage. Therefore, the circuit demands only as much peak current from the battery as output conditions require, minimizing the peak current from the battery. An external resistor

between CHG and GND controls the output recharge time. A large resistor increases peak inductor current which speeds up recovery time. Calculate the resistor as follows:

$$R_{CHG} = \left[ \left( \frac{(I_{BURST} \cdot V_{OUT} \cdot D_{GSM})}{V_{IN(MIN)} \cdot (1 - D_{GSM})} \right) + 0.1 \right] \cdot \left[ \frac{V_{IN(MIN)}}{V_{DROOP} \cdot g_{mCHG} \cdot V_{REF} \cdot g_{mFB} \cdot (1 - tol)} \right]$$

where:

$R_{CHG}$  is the external resistor

$I_{BURST}$  is the peak burst current expected

$D_{GSM}$  is the duty cycle of GSM

$V_{IN}$  is the input voltage

$V_{OUT}$  is the output voltage

$V_{REF} = 1.25V$

$V_{DROOP}$  is the drop in output voltage during the current burst

$g_{mCHG}$  is the internal transconductance = 0.8A/V

$g_{mFB}$  is the feedback transconductance = 200 $\mu$ A/V

tol is the tolerance of the  $R_{CHG}$  resistor

For example, for  $I_{BURST} = 2.66A$ ,  $V_{DROOP} = 0.36V$ ,  $V_{IN} = +2.7V$ , and  $V_{OUT} = 3.6V$ , then  $R_{CHG} = 31.5k\Omega$ , using a 5% tolerance resistor.

The recovery time for a 40.2k $\Omega$   $R_{CHG}$  is shorter than that with an 18k $\Omega$   $R_{CHG}$ , but the peak battery current is higher. See Switching Waveforms (GSM Pulsed Load 1A,  $R_{CHG} = 40.2k\Omega$ ) and Switching Waveforms (GSM Pulsed Load 1A,  $R_{CH} = 18k\Omega$ ) in *Typical Operating Characteristics*.

### Inductor Selection

The value of the inductor determines the switching frequency. Calculate the switching frequency as:

$$f = V_{IN} [1 - (V_{IN} / V_{OUT})] / (L \cdot I_{RIPPLE})$$

where  $f$  is the switching frequency,  $V_{IN}$  is the input voltage,  $V_{OUT}$  is the output voltage,  $L$  is the inductor value, and  $I_{RIPPLE}$  is the ripple current expected, typically 0.2A. Using a lower value inductor increases the frequency and reduces the physical size of the inductor. A typical frequency is from 150kHz to 1MHz (see Switching Frequency vs. Inductance in the *Typical Operating Characteristics*).

# Step-Up DC-DC Converters with Precise, Adaptive Current Limit for GSM

## Output (Reservoir) Capacitor

The value of the output capacitor determines the amount of power available to deliver to the power amplifier during the RF burst. A larger output capacitor with low ESR reduces the amount of output voltage droop during an RF burst. Use the following equation to determine capacitor size when ON is synchronized to the RF burst:

$$C_{OUT} = \frac{D_{GSM} \cdot I_{BURST} \cdot t_{GSM}}{(V_{DROOP} - I_{BURST} \cdot ESR_{OUTPUT\ CAPACITOR})(1 - tol)}$$

where  $C_{OUT}$  is the output capacitor,  $I_{BURST}$  is the peak power amplifier burst current,  $t_{GSM}$  is the current pulse period,  $D_{GSM}$  is the duty cycle,  $tol$  is the capacitor tolerance, and  $V_{DROOP}$  is the acceptable drop in the output during the current burst.

For example, when used in a typical GSM system,  $t_{GSM} = 4.62ms$ ,  $I_{BURST} = 2.66A$  for a +3.6V system (1.42A for a +5.5V system), and with a droop of less than 10%, the value of the capacitor is  $5.3mF \pm 20\%$ .

The output capacitor also determines the constant-load (ON connected to  $V_{CC}$ ) ripple voltage. The output ripple is:

$$V_{RIPPLE} = I_{RIPPLE} \cdot ESR(OUTPUT\ CAPACITOR)$$

where  $I_{RIPPLE}$  is typically 0.2A.

## Typical Application Circuits

The current limit of the MAX1687 can be set by an external DAC (Figure 6a), making it variable by using a microcontroller. The MAX1687 is the choice for systems interfacing with a microcontroller, but may also be used with fixed current limit (Figure 6b). The MAX1688 can monitor the droop of the output voltage to set the current limit, maximizing battery life. The MAX1688 is suitable for systems demanding variable burst currents (Figures 6a, 6b, and 7) as well as variable input voltages.

## Layout

The MAX1687/MAX1688's high-frequency operation and high peak currents make PC board layout critical to minimize ground bounce and noise. Locate input bypass and output filter capacitors as close to the device pins as possible. All connections to OUT and FB should also be kept as short as possible. Use a low-inductance ground plane. Connect the ground leads of the input capacitor, output capacitor, and PGND pins in a star configuration to the ground plane. Table 1 lists suggested suppliers. Refer to the MAX1687/MAX1688 evaluation kit manual for a suggested surface-mount layout and a list of suggested components.

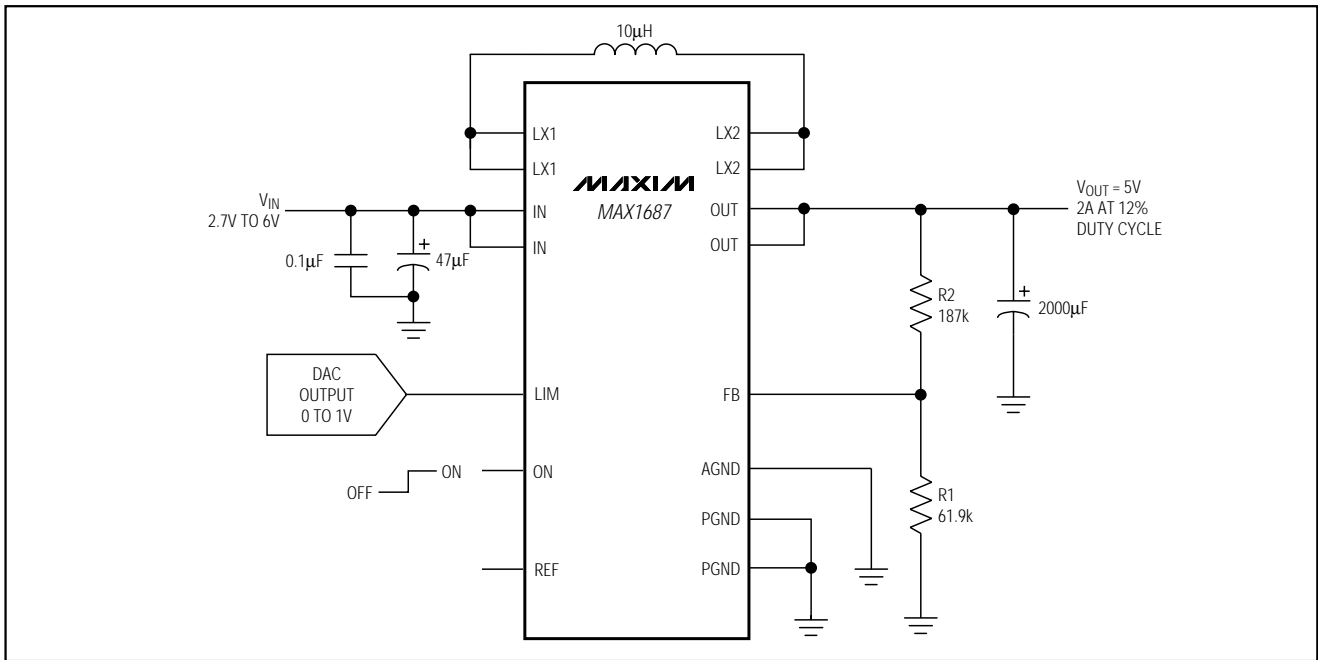

Figure 6a. MAX1687 Typical Application Circuit (GSM Pulsed Load)

# Step-Up DC-DC Converters with Precise, Adaptive Current Limit for GSM

MAX1687/MAX1688

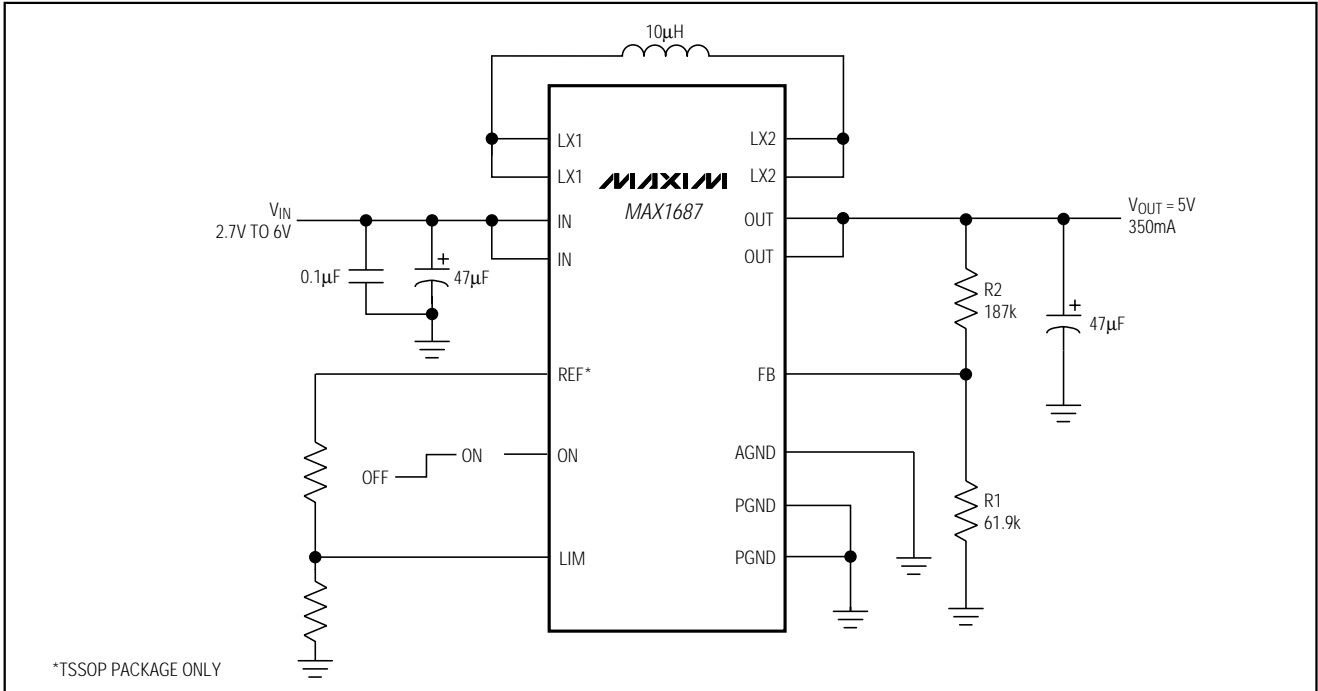

Figure 6b. MAX1687 Typical Application Circuit (Fixed Non-Pulsed Load)

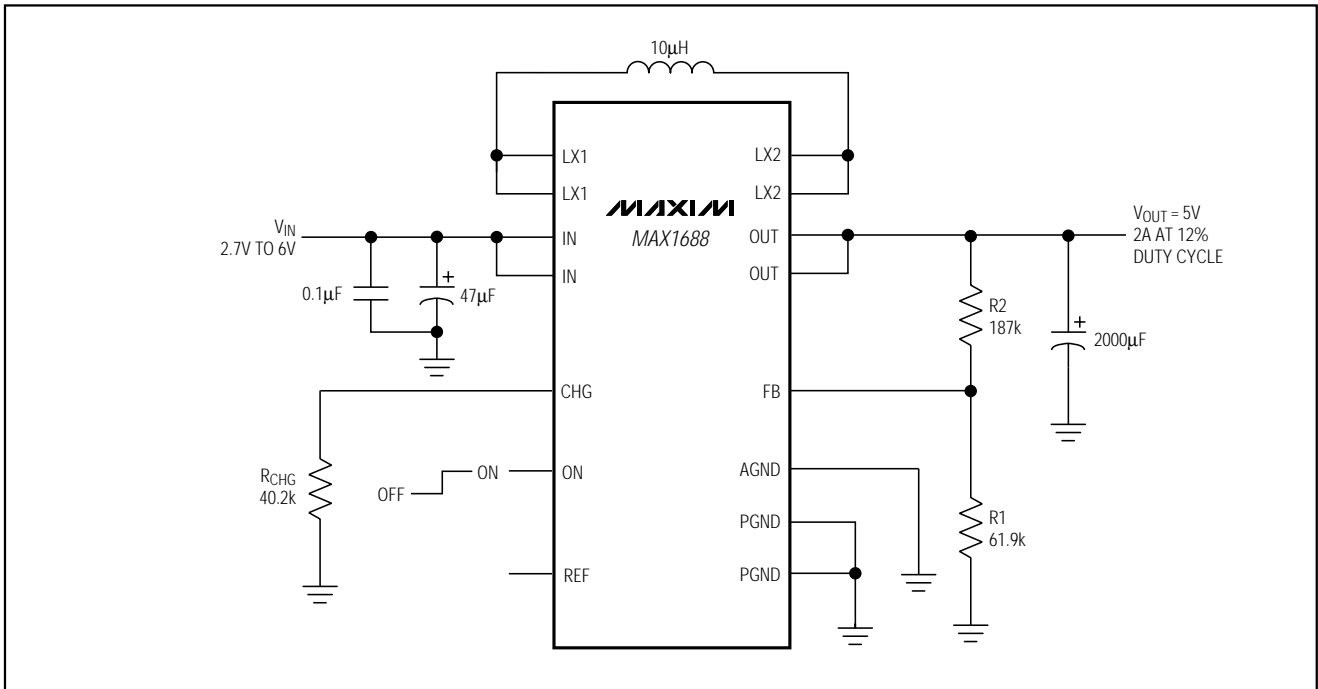
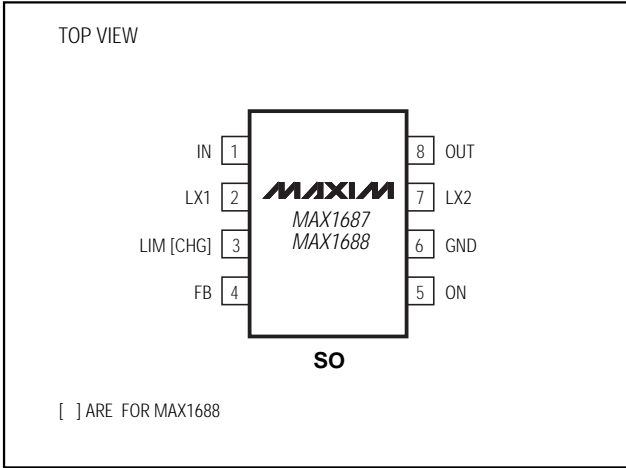

Figure 7. MAX1688 Typical Application Circuit (GSM Pulsed Load)

# Step-Up DC-DC Converters with Precise, Adaptive Current Limit for GSM

## Pin Configurations (continued)



## Table 1. Component Suppliers

COMPANY	FAX	PHONE
AVX	207-283-1941	207-282-5111
CoilCraft	708-639-6400	708-639-1469
Coiltronics	561-241-9339	561-241-7876
Murata-Erie	404-736-3030	404-736-1300
Sumida	81-3-3607-5428	708-956-0666

## Chip Information

TRANSISTOR COUNT: 1920

## Package Information

SYMBOL	COMMON DIMENSIONS			
	MILLIMETERS		INCHES	
	MIN.	MAX.	MIN.	MAX.
A		1.10		.043
A <sub>1</sub>	0.05	0.15	.002	.006
A <sub>2</sub>	0.85	0.95	.033	.037
b	0.19	0.30	.007	.012
b <sub>1</sub>	0.19	0.25	.007	.010
c	0.090	0.20	.0035	.008
c <sub>1</sub>	0.090	0.135	.0035	.0053
D	SEE VARIATIONS		SEE VARIATIONS	
E	4.30	4.50	.169	.177
e	0.65	BSC	.026	BSC
H	6.25	6.30	.246	.256
L	0.50	0.70	.020	.028
N	SEE VARIATIONS		SEE VARIATIONS	
Y	2.85	3.15	.112	.124
α	0°	8°	0°	8°

JEDEC	MO-153	N	VARIATIONS					
			MILLIMETERS		INCHES			
			MIN.	MAX.	MIN.	MAX.		
		AB	14	D	4.90	5.10	.193	.201
		AC	16	D	4.90	5.10	.193	.201
		AC-EP	16	D	4.90	5.10	.193	.201
				X	2.85	3.15	.112	.124
		AD	20	D	6.40	6.60	.252	.260
		AD-EP	20	D	6.40	6.60	.252	.260
				X	4.00	4.34	.157	.171
		AF	24	D	7.70	7.90	.303	.311
		AF	28	D	9.60	9.80	.378	.386
		AF-EP		D	9.60	9.80	.378	.386
				X	5.35	5.65	.211	.222

NOTES:

- DIMENSIONS D AND E DO NOT INCLUDE FLASH.
- MOLD FLASH OR PROTRUSIONS NOT TO EXCEED .15 mm PER SIDE.
- CONTROLLING DIMENSION: MILLIMETER.
- MEETS JEDEC OUTLINE MO-153 VARIATIONS AB, AC, AD, AE, AF.
- DIMENSIONS X AND Y APPLY TO EXPOSED PAD (EP) VERSIONS ONLY.
- EXPOSED PAD FLUSH WITH BOTTOM OF PACKAGE WITHIN .002".

## Looking for pricing, stock, or lifecycle information?

Click below to explore more details on WIN SOURCE:

 [View MAX1688ESA+](#) on WIN SOURCE

 [Maxim Integrated](#) Information

## Optimize Your Supply Chain with WIN SOURCE Solutions

-  Global Sourcing Solution
-  Obsolete Management
-  Cost Control Management
-  Shortage Management
-  Alternative Solution
-  Excess Inventory Management