



**THE DATASHEET OF  
MAX1708EEE+T**





# High-Frequency, High-Power, Low-Noise, Step-Up DC-DC Converter

MAX1708

## General Description

The MAX1708 sets a new standard of space savings for high-power, step-up DC-DC conversion. It delivers up to 10W at a fixed (3.3V or 5V) or adjustable (2.5V to 5.5V) output, using an on-chip power MOSFET from a 0.7V to 5V supply.

Fixed-frequency PWM operation ensures that the switching noise spectrum is constrained to the 600kHz fundamental and its harmonics, allowing easy postfiltering for noise reduction. External clock synchronization capability allows for even tighter noise spectrum control. Quiescent power consumption is less than 1mW to extend operating time in battery-powered systems.

Two control inputs (ONA,  $\overline{\text{ONB}}$ ) allow simple push-on, push-off control through a single momentary push-button switch, as well as conventional on/off logic control. The MAX1708 also features programmable soft-start and current limit for design flexibility and optimum performance with batteries. The maximum RMS switch current rating is 5A. For a device with a higher (10A) switch current rating, refer to the MAX1709 data sheet.

## Applications

Routers, Servers, Workstations, Card Racks  
Local 2.5V to 3.3V or 5V Conversion  
Local 3.3V to 5V Conversion  
3.6V or 5V RF PAs in Communications Handsets

## Features

- ◆ On-Chip 5A Power MOSFET
- ◆ 5V, 2A Output from a 3.3V Input
- ◆ Fixed 3.3V or 5V Output Voltage or Adjustable (2.5V to 5.5V)
- ◆ Input Voltage Range Down to 0.7V
- ◆ Low Power Consumption  
1mW Quiescent Power  
1 $\mu$ A Current in Shutdown Mode
- ◆ Low-Noise, Constant Frequency Operation (600kHz)
- ◆ Synchronizable Switching Frequency (350kHz to 1000kHz)
- ◆ Small QSOP Package

## Ordering Information

PART	TEMP. RANGE	PIN-PACKAGE
MAX1708EEE+	-40°C to +85°C	16 QSOP

+Denotes a lead(Pb)-free/RoHS-compliant package.

## Typical Operating Circuit

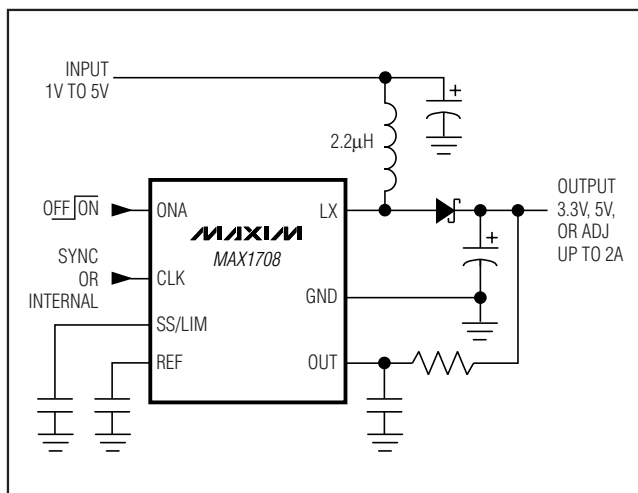

## Pin Configuration

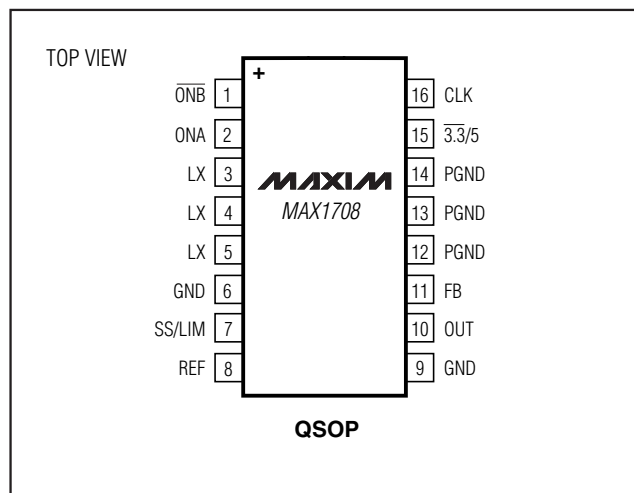

# High-Frequency, High-Power, Low-Noise, Step-Up DC-DC Converter

## ABSOLUTE MAXIMUM RATINGS

ONA,  $\overline{\text{ONB}}$ , OUT, SS/LIM, 3.3/5 to GND .....-0.3V to +6.0V  
 LX to PGND .....-0.3V to +6.0V  
 FB, CLK, REF to GND.....-0.3V to ( $V_{\text{OUT}} + 0.3\text{V}$ )  
 PGND to GND .....-0.3V to +0.3V  
 Continuous Power Dissipation ( $T_{\text{A}} = +70^{\circ}\text{C}$ )  
 QSQP (derate 8.30mW/ $^{\circ}\text{C}$  above +70 $^{\circ}\text{C}$ ). .....667mW

Operating Temperature Range .....-40 $^{\circ}\text{C}$  to +85 $^{\circ}\text{C}$   
 Junction Temperature.....+150 $^{\circ}\text{C}$   
 Storage Temperature Range .....-65 $^{\circ}\text{C}$  to +150 $^{\circ}\text{C}$   
 Lead Temperature (soldering, 10s) .....+300 $^{\circ}\text{C}$   
 Soldering Temperature (reflow) .....+260 $^{\circ}\text{C}$

Stresses beyond those listed under "Absolute Maximum Ratings" may cause permanent damage to the device. These are stress ratings only, and functional operation of the device at these or any other conditions beyond those indicated in the operational sections of the specifications is not implied. Exposure to absolute maximum rating conditions for extended periods may affect device reliability.

## ELECTRICAL CHARACTERISTICS

( $V_{\text{OUT}} = V_{\text{CLK}} = 3.6\text{V}$ ,  $\text{ONA} = \overline{\text{ONB}} = \text{FB} = \text{GND}$ ,  $T_{\text{A}} = 0^{\circ}\text{C}$  to +85 $^{\circ}\text{C}$ , unless otherwise noted. Typical values are at  $T_{\text{A}} = +25^{\circ}\text{C}$ .)

PARAMETER	CONDITIONS	MIN	TYP	MAX	UNITS	
Output Voltage	$V_{\text{FB}} < 0.1\text{V}$ (Note 1)	$\overline{3.3}/5 = \text{GND}$ , $I_{\text{SW}} = 0.5\text{A}$	3.26	3.34	3.42	V
		$\overline{3.3}/5 = \text{OUT}$ , $I_{\text{SW}} = 0.5\text{A}$	4.90	5.05	5.20	
Load Regulation	Measured between $0.5\text{A} < I_{\text{SW}} < 1.5\text{A}$ (Note 2)		-0.40	-0.60	%/A	
FB Regulation Voltage ( $V_{\text{FB}}$ )	$I_{\text{SW}} = 0.5\text{A}$	1.215	1.240	1.265	V	
FB Input Current	$V_{\text{FB}} = 1.5\text{V}$		1	200	nA	
Output Voltage Adjust Range		2.5		5.5	V	
Output Undervoltage Lockout	Rising and falling (Note 3)	2.0		2.3	V	
Frequency in Startup Mode	$V_{\text{OUT}} = 1.5\text{V}$	40		400	kHz	
Minimum Startup Voltage	$I_{\text{OUT}} < 1\text{mA}$ , $T_{\text{A}} = +25^{\circ}\text{C}$ (Note 4)		0.9	1.1	V	
Minimum Operating Voltage	(Note 5)		0.7		V	
Soft-Start Pin Current	$V_{\text{SS/LIM}} = 1\text{V}$	3.2	4	5.0	$\mu\text{A}$	
OUT Supply Current	$V_{\text{FB}} = 1.5\text{V}$ (Note 6)		200	300	$\mu\text{A}$	
OUT Leakage Current In Shutdown	$V_{\overline{\text{ONB}}} = 3.6\text{V}$		0.1	2	$\mu\text{A}$	
LX Leakage Current	$V_{\text{LX}} = V_{\overline{\text{ONB}}} = V_{\text{OUT}} = 5.5\text{V}$		1	25	$\mu\text{A}$	
N-Channel Switch On-Resistance			30	80	m $\Omega$	
N-Channel Current Limit	SS/LIM = open	4.5	5.3	7.0	A	
	SS/LIM = 150k $\Omega$ to GND	1.80	3.00	3.85		
RMS Switch Current				5	A <sub>RMS</sub>	
Reference Voltage	$I_{\text{REF}} = 0\text{mA}$	1.245	1.260	1.275	V	
Reference Load Regulation	$-1\mu\text{A} \leq I_{\text{REF}} \leq 50\mu\text{A}$		4	10	mV	
Reference Supply Rejection	$2.5\text{V} \leq V_{\text{OUT}} \leq 5.5\text{V}$		0.2	5	mV	
Input Low Level (Note 7)	ONA, $\overline{\text{ONB}}$ , $\overline{3.3}/5$ , $1.2\text{V} < V_{\text{OUT}} < 5.5\text{V}$			$0.2 \times V_{\text{OUT}}$	V	
	CLK, $2.7\text{V} < V_{\text{OUT}} < 5.5\text{V}$			$0.2 \times V_{\text{OUT}}$		

# High-Frequency, High-Power, Low-Noise, Step-Up DC-DC Converter

MAX1708

## ELECTRICAL CHARACTERISTICS (continued)

( $V_{OUT} = V_{CLK} = 3.6V$ ,  $ON_A = \overline{ONB} = FB = GND$ ,  $T_A = 0^{\circ}C$  to  $+85^{\circ}C$ , unless otherwise noted. Typical values are at  $T_A = +25^{\circ}C$ .)

PARAMETER	CONDITIONS	MIN	TYP	MAX	UNITS
Input High Level	$ON_A, \overline{ONB}, \overline{3.3/5}, 1.2V < V_{OUT} < 5.5V$	$0.8 \times V_{OUT}$			V
	CLK, $2.7V < V_{OUT} < 5.5V$	$0.8 \times V_{OUT}$			
Logic Input Current	$V_{ON_A}, V_{\overline{ONB}}, V_{CLK}, V_{\overline{3.3/5}} = 0V, 5.5V$	-1		1	$\mu A$
Internal Oscillator Frequency		520	600	680	kHz
Maximum Duty Cycle		82	88	94	%
External Clock Frequency Range		350		1000	kHz
CLK Pulse Width	(Note 8)	100			ns
CLK Rise/Fall Time	(Note 8)			50	Ns

## ELECTRICAL CHARACTERISTICS

( $V_{OUT} = V_{CLK} = 3.6V$ ,  $ON_A = \overline{ONB} = FB = GND$ ,  $T_A = -40^{\circ}C$  to  $+85^{\circ}C$ , unless otherwise noted.) (Note 9)

PARAMETER	CONDITIONS	MIN	MAX	UNITS	
Output Voltage	$V_{FB} < 0.1V, V_{IN} = 2.4V$ (Note 1)	$\overline{3.3/5} = GND, I_{SW} = 0.5A$	3.24	3.45	V
		$\overline{3.3/5} = OUT, I_{SW} = 0.5A$	4.90	5.22	
FB Regulation Voltage	$I_{SW} = 0.5A$	1.20	1.28	V	
FB Input Current ( $V_{FB}$ )	$V_{FB} = 1.5V$		200	nA	
Load Regulation	Measured between $0.5A < I_{SW} < 1.5A$ (Note 2)		-0.60	%/A	
Soft-Start Pin Current	$V_{SS/LIM} = 1V$	3.2	5.2	$\mu A$	
OUT Leakage Current in Shutdown	$V_{\overline{ONB}} = 3.6V$		2	$\mu A$	
OUT Supply Current	$V_{FB} = 1.5V$ (Note 6)		300	$\mu A$	
N-Channel Switch On-Resistance			80	m $\Omega$	
N-Channel Current Limit	SS/LIM = unconnected	4.5	7.5	A	
	SS/LIM = 150k $\Omega$ to GND	1.8	4.0		
Reference Voltage	$I_{REF} = 0mA$	1.24	1.28	V	

# High-Frequency, High-Power, Low-Noise, Step-Up DC-DC Converter

## ELECTRICAL CHARACTERISTICS (continued)

( $V_{OUT} = V_{CLK} = 3.6V$ ,  $ON_A = \overline{ON}_B = FB = GND$ ,  $T_A = -40^{\circ}C$  to  $+85^{\circ}C$ , unless otherwise noted.) (Note 9)

PARAMETER	CONDITIONS	MIN	MAX	UNITS
Input Low Level (Note 7)	$ON_A, \overline{ON}_B, \overline{3.3}/5, 1.2V < V_{OUT} < 5.5V$		$0.2 \times V_{OUT}$	V
	CLK, $2.7V < V_{OUT} < 5.5V$		$0.2 \times V_{OUT}$	
Input High Level	$ON_A, \overline{ON}_B, \overline{3.3}/5, 1.2V < V_{OUT} < 5.5V$	$0.8 \times V_{OUT}$		V
	CLK, $2.7V < V_{OUT} < 5.5V$	$0.8 \times V_{OUT}$		
Logic Input Current	$V_{ON_A}, \overline{V_{ON}_B}, V_{CLK}, \overline{V_{3.3}/5} = 0V, 5.5V$	-1	1	$\mu A$
Internal Oscillator Frequency		500	700	kHz
Maximum Duty Cycle		80	95	%
External Clock Frequency Range		350	1000	kHz
CLK Pulse Width	(Note 8)	100		ns
CLK Rise/Fall Time	(Note 8)		50	Ns

**Note 1:** Output voltage is specified at 0.5A switch current  $I_{SW}$ , which is equivalent to approximately  $0.5A \times (V_{IN} / V_{OUT})$  of load current.

**Note 2:** Load regulation is measured by forcing specified switch current and straight-line calculation of change in output voltage in external feedback mode. Note that the equivalent load current is approximately  $I_{SW} \times (V_{IN} / V_{OUT})$ .

**Note 3:** Until undervoltage lockout is reached, the device remains in startup mode. Do not apply full load until this voltage is reached.

**Note 4:** Startup is tested with Figure 1's circuit. Output current is measured when both the input and output voltages are applied.

**Note 5:** Minimum operating voltage. The MAX1708 is bootstrapped and will operate down to a 0.7V input once started.

**Note 6:** Supply current is measured from the output voltage (3.3V) to the OUT pin. This correlates directly with actual input supply current but is reduced in value according to the step-up ratio and efficiency.

**Note 7:**  $ON_A$  and  $\overline{ON}_B$  inputs have approximately 0.15V hysteresis.

**Note 8:** Guaranteed by design, not production tested.

**Note 9:** Specifications to  $-40^{\circ}C$  are guaranteed by design, not production tested.

# High-Frequency, High-Power, Low-Noise, Step-Up DC-DC Converter

## Typical Operating Characteristics

(Circuit of Figure 1,  $T_A = +25^\circ\text{C}$ , unless otherwise noted.)

MAX1708

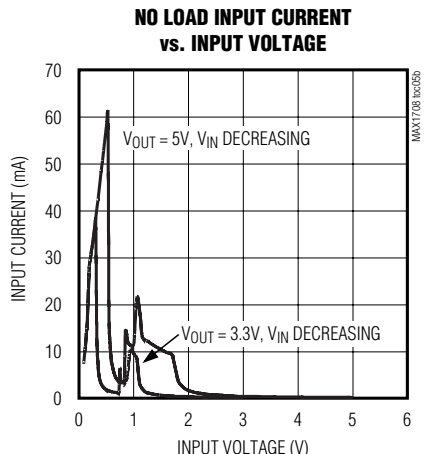
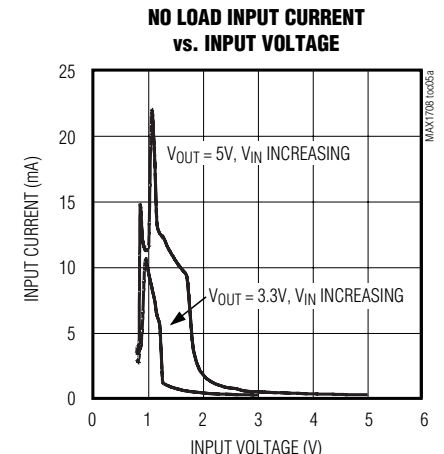
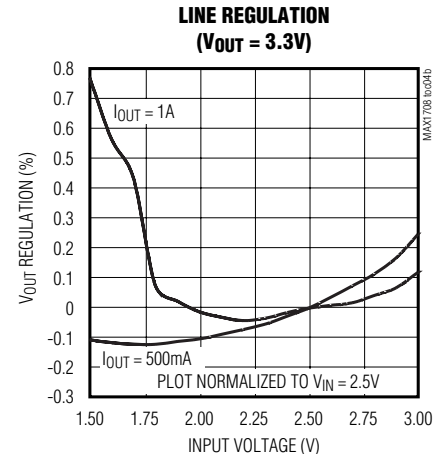
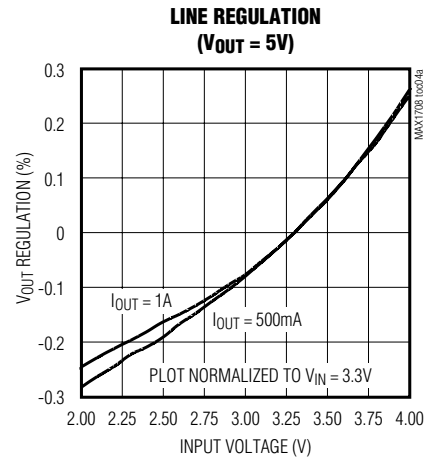
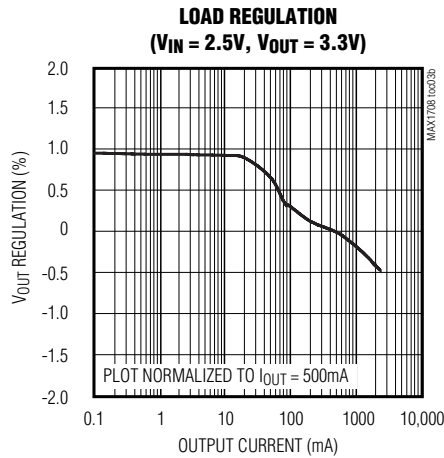
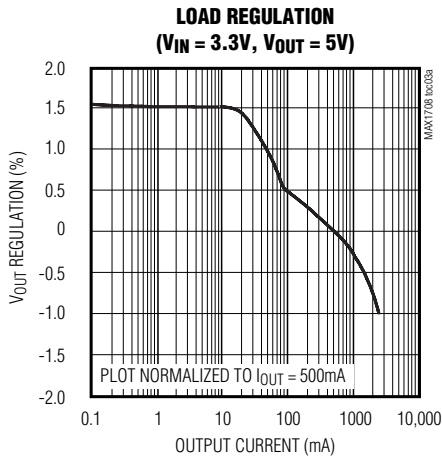
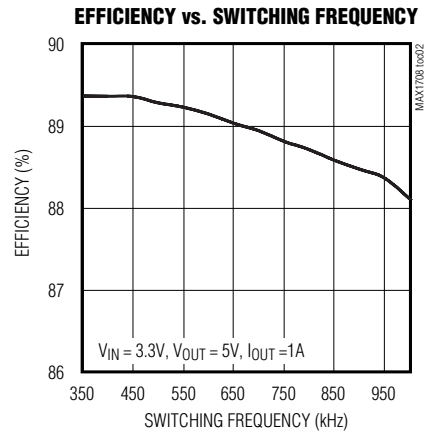
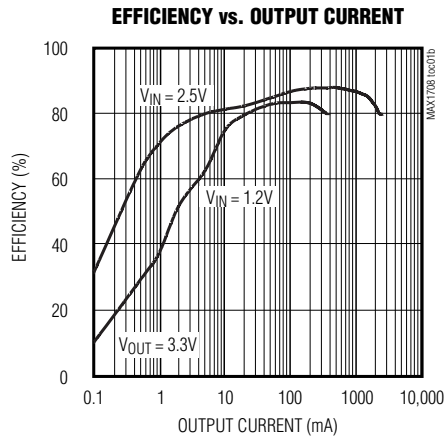
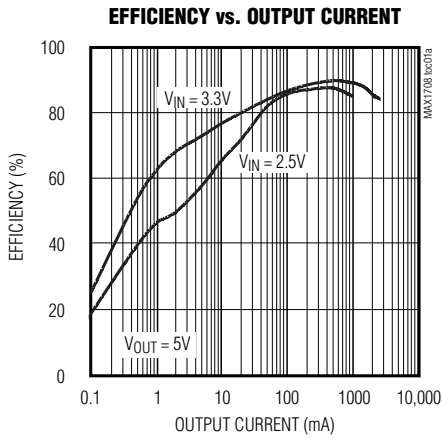

# High-Frequency, High-Power, Low-Noise, Step-Up DC-DC Converter

## Typical Operating Characteristics (continued)

(Circuit of Figure 1,  $T_A = +25^\circ\text{C}$ , unless otherwise noted.)

**STARTUP VOLTAGE vs. LOAD CURRENT**  
( $V_{OUT} = 5V$ )

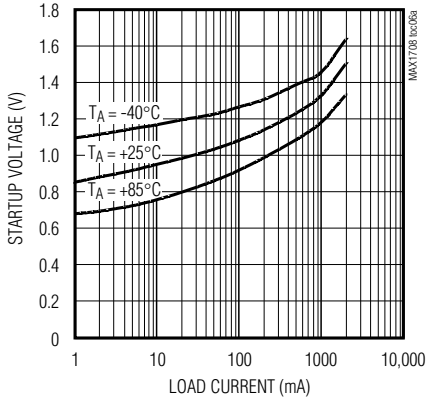

**STARTUP VOLTAGE vs. LOAD CURRENT**  
( $V_{OUT} = 3.3V$ )

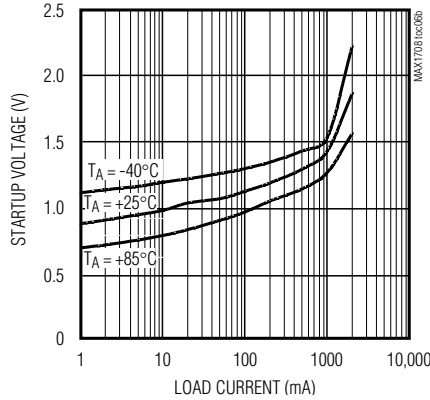

**SWITCHING FREQUENCY vs. TEMPERATURE**

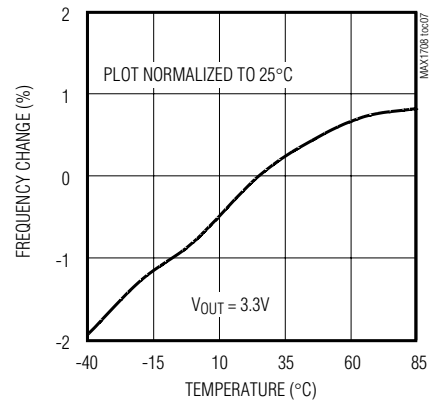

**NOISE vs. FREQUENCY**

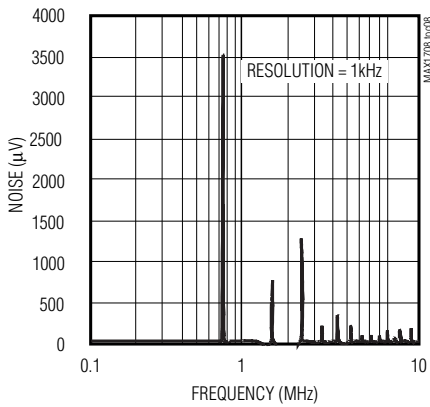

**SWITCH CURRENT LIMIT vs. SS/LIM RESISTANCE**

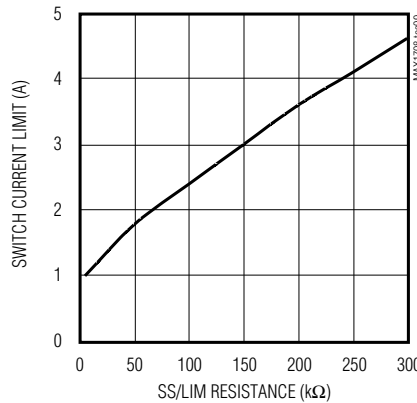

**SWITCH CURRENT LIMIT vs. TEMPERATURE**

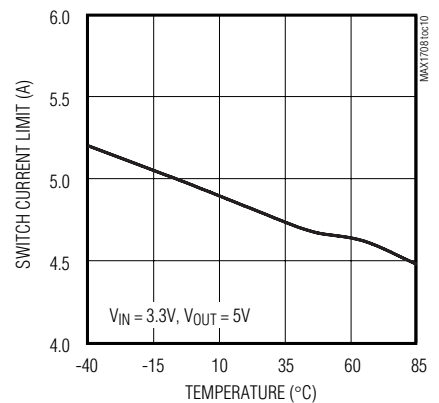

**HEAVY SWITCHING WAVEFORM**

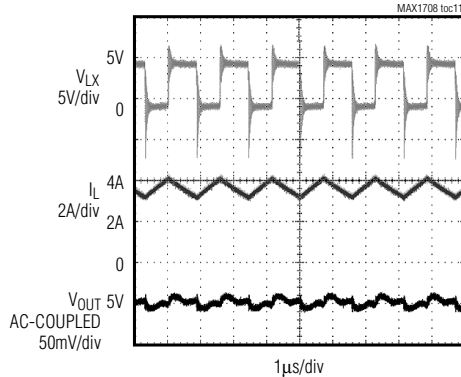

**LINE TRANSIENT RESPONSE**

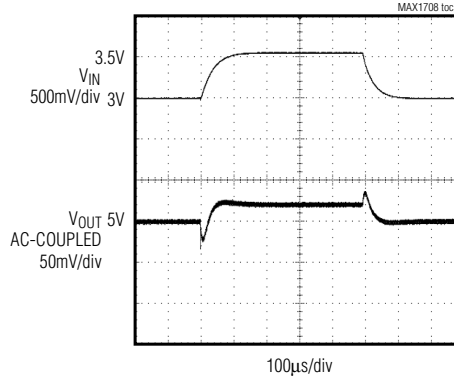

# High-Frequency, High-Power, Low-Noise, Step-Up DC-DC Converter

MAX1708

## Typical Operating Characteristics (continued)

(Circuit of Figure 1,  $T_A = +25^\circ\text{C}$ , unless otherwise noted.)

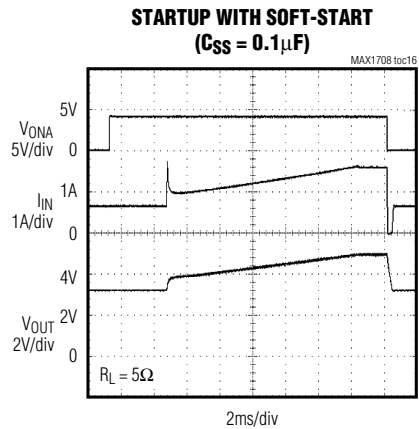
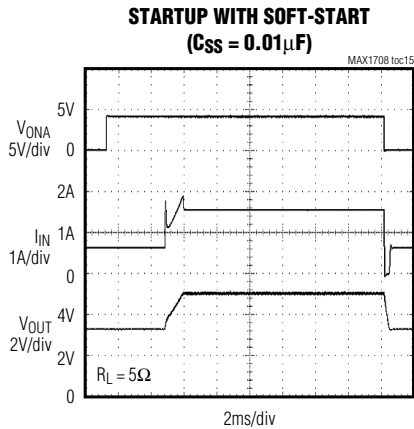
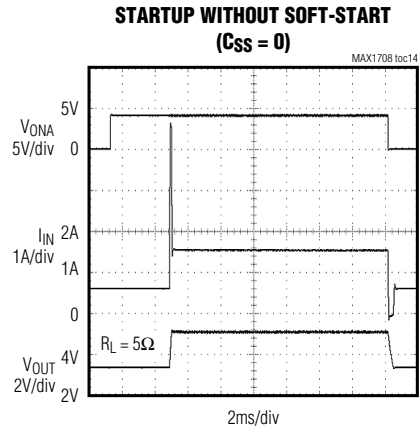
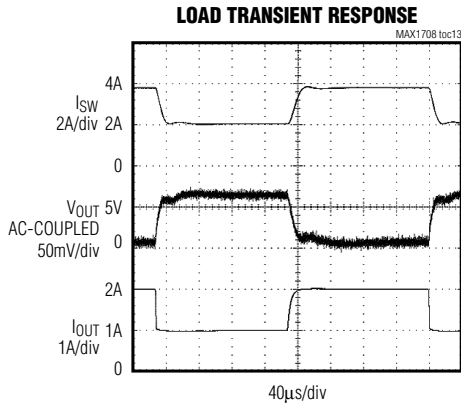

# High-Frequency, High-Power, Low-Noise, Step-Up DC-DC Converter

## Pin Description

PIN	NAME	FUNCTION
1	$\overline{\text{ONB}}$	Shutdown Input. When $\overline{\text{ONB}}$ = high <b>and</b> ONA = low, the device turns off (Table 1).
2	ONA	On-Control Input. When ONA = high <b>or</b> $\overline{\text{ONB}}$ = low, the device turns on (Table 1).
3, 4, 5	LX	Drain of N-Channel Power Switch. Connect pins 3, 4, and 5 together with wide traces. Connect an external Schottky diode from LX to V <sub>OUT</sub> . (Figure 1)
6, 9	GND	Ground
7	SS/LIM	Soft-Start and/or Current-Limit Input. Connect a capacitor from SS/LIM to GND to control the rate at which the device reaches current limit (soft-start). To reduce the current limit from the preset values, connect a resistor from SS/LIM to GND (see <i>Design Procedure</i> ). During shutdown, SS/LIM is internally pulled to GND to discharge the soft-start capacitor.
8	REF	Voltage Reference Output. Bypass with a 0.22 $\mu$ F capacitor to GND. Maximum REF load is 50 $\mu$ A.
10	OUT	Output Voltage Sense Input. The device is powered from OUT. Bypass with a 0.1 $\mu$ F capacitor to PGND with less than 5mm trace length. Connect a 2 $\Omega$ series resistor from the output filter capacitor (0.1 $\mu$ F) to OUT (Figure 1).
11	FB	DC-DC Converter Feedback Input. Connect FB to GND for internally set output voltage (see $\overline{3.3}/5$ pin description). Connect a resistor-divider from the output to set the output voltage in the 2.5V to 5.5V range. FB regulates to 1.24V (Figure 4).
12, 13, 14	PGND	Power Ground, Source of N-Channel Power MOSFET Switch. Connect pins 12, 13, and 14 together with wide traces.
15	$\overline{3.3}/5$	Output Voltage Selection Input. When FB is connected to GND, the regulator uses internal feedback to set the output voltage. $\overline{3.3}/5$ = low sets output to 3.3V; $\overline{3.3}/5$ = high sets output to 5V. If an external divider is used at FB, connect $\overline{3.3}/5$ to ground.
16	CLK	Clock Input for the DC-DC Converter. Connect to OUT for internal oscillator. Drive CLK with an external clock for external synchronization.

# High-Frequency, High-Power, Low-Noise, Step-Up DC-DC Converter

MAX1708

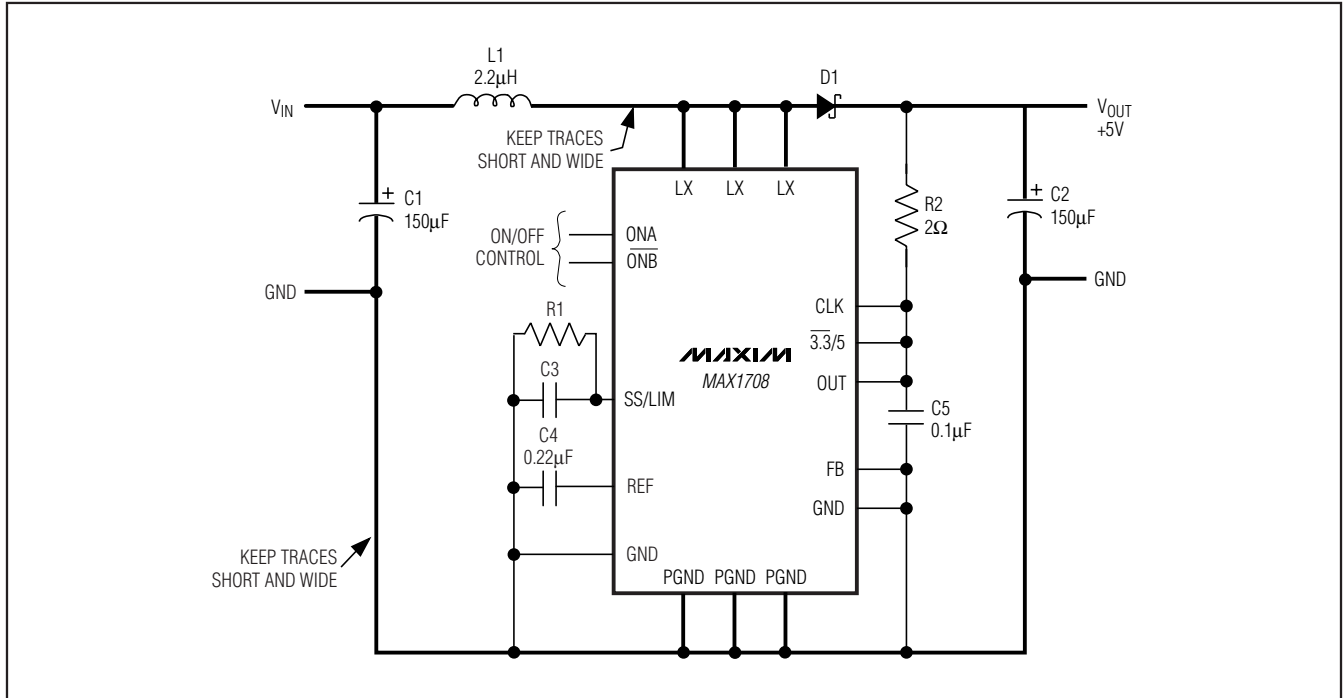

Figure 1. Standard Operating Circuit

## Detailed Description

The MAX1708 step-up converter offers high efficiency and high integration for high-power applications. It operates with an input voltage as low as 0.7V and is suitable for single- to 3-cell battery inputs, as well as 2.5V or 3.3V regulated supply inputs. The output voltage is preset to 3.3V or 5.0V or can be adjusted with external resistors for voltages between 2.5V to 5.5V.

The MAX1708 internal N-channel MOSFET switch is rated for 5A (RMS value) and can deliver loads to 2A, depending on input and output voltages. For flexibility, the current limit and soft-start rate are independently programmable.

A 600kHz switching frequency allows for a small inductor to be used. The switching frequency is also synchronizable to an external clock ranging from 350kHz to 1MHz.

### ONA, $\overline{\text{ONB}}$

The logic levels at ONA and  $\overline{\text{ONB}}$  turn the MAX1708 on or off. When ONA = 1 or  $\overline{\text{ONB}}$  = 0, the device is on. When ONA = 0 and  $\overline{\text{ONB}}$  = 1, the device is off (Table 1). Logic high on-control can be implemented by connecting  $\overline{\text{ONB}}$  high and using ONA for shutdown.

Implement inverted single-line on/off control by grounding ONA and toggling  $\overline{\text{ONB}}$ . Implement momentary pushbutton on/off as described in the *Applications Information* section. Both inputs have approximately 0.15V of hysteresis.

### Switching Frequency

The MAX1708 switches at the fixed-frequency internal oscillator rate (600kHz) or can be synchronized to an external clock. Connect CLK to OUT for internal clock operation. Apply a clock signal to CLK to synchronize to an external clock. The MAX1708 will synchronize to a new external clock rate in two cycles and will take approximately 40µs to revert to its internal clock frequency once the external clock pulses stop and CLK is driven high. Table 2 summarizes oscillator operation.

### Operation

The MAX1708 switches at a constant frequency (600kHz) and modulates the MOSFET switch pulse width to control the power transferred per cycle and regulate the voltage across the load. In low-noise applications, the fundamental and the harmonics generated by the fixed switching frequency are easily filtered out. Figure 2 shows the simplified functional diagram for the MAX1708. Figure 3 shows the simplified PWM con-

# High-Frequency, High-Power, Low-Noise, Step-Up DC-DC Converter

Table 1. On/Off Logic Control

ONA	ONB	MAX1708
0	0	On
0	1	Off
1	0	On
1	1	On

Table 2. Selecting Switching Frequency

CLK	MODE
0	Not allowed
1	PWM
External clock (350kHz–1000kHz)	Synchronized PWM

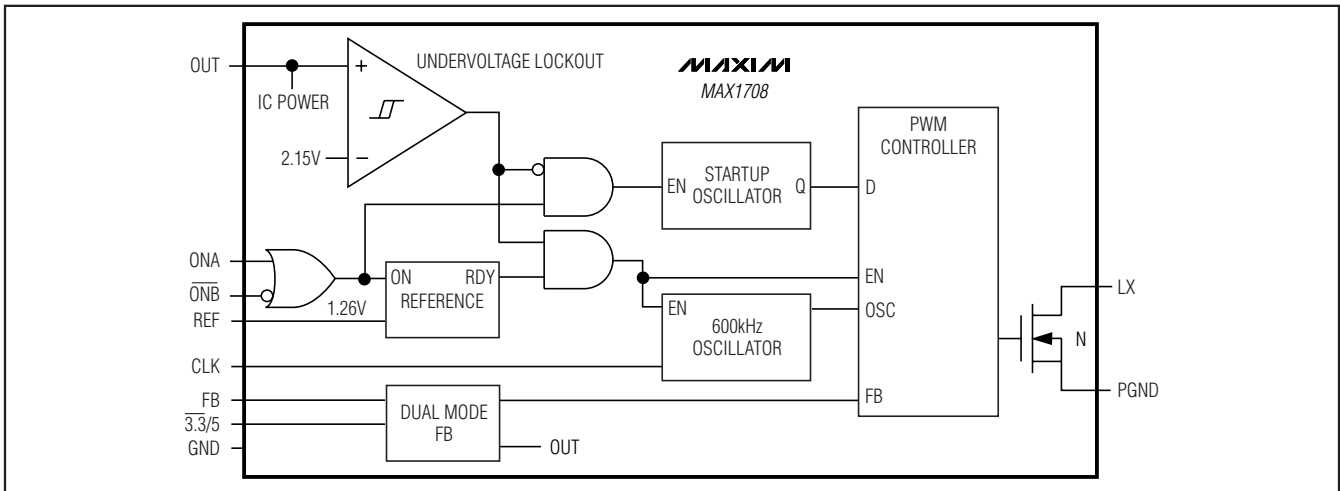

Figure 2. Simplified Functional Diagram

troller functional diagram. The MAX1708 enters synchronized current-mode PWM when a clock signal ( $350\text{kHz} < f_{\text{CLK}} < 1\text{MHz}$ ) is applied to CLK. For wireless or noise-sensitive applications, this ensures that switching harmonics are predictable and kept outside the IF frequency band(s). High-frequency operation permits low-magnitude output ripple voltage and minimum inductor and filter capacitor size. Switching losses will increase at higher frequencies (see *MAX1708 IC Power Dissipation*).

### Setting the Output Voltage

The MAX1708 features Dual Mode™ operation. When FB is connected to ground, the MAX1708 generates a fixed output voltage of either 3.3V or 5V, depending on the logic applied to the 3.3/5 input (Figure 1). The output can be configured for other voltages, using two external resistors as shown in Figure 4. To set the output voltage externally, choose an R3 value that is large enough to minimize load at the output but small enough to minimize errors due to leakage and the time constant to FB. A value of  $R4 \leq 50\text{k}\Omega$  is required

$$R4 = R3 \left( \frac{V_{\text{OUT}}}{V_{\text{FB}}} - 1 \right)$$

where  $V_{\text{FB}} = 1.24\text{V}$ .

### Soft-Start/Current Limit Adjustment (SS/LIM)

The soft-start pin allows the soft-start time to be adjusted by connecting a capacitor from SS/LIM to GND. Select capacitor C3 (see Figure 1):

$$t_{\text{SS}} = 4\text{ms} + [110 \times C3 \text{ (in } \mu\text{F)}]$$

where  $t_{\text{SS}}$  is the time (in milliseconds) it takes output to reach its final value.

To improve efficiency or reduce inductor size at reduced load currents, the current limit can be reduced from its nominal value (see *Electrical Characteristics*). A resistor (R1 in Figure 1) between SS/LIM and ground reduces the current limit as follows:

$$R1 = 312\text{k}\Omega \times \frac{I_1}{I_{\text{LIM}}}$$

where  $I_1$  is the desired current limit in amperes and  $R1 \leq 312\text{k}\Omega$ .  $I_{\text{LIM}} = 5\text{A}$ , if R1 is omitted.

Dual Mode is a trademark of Maxim Integrated Products.

# High-Frequency, High-Power, Low-Noise, Step-Up DC-DC Converter

**Table 3. Component Selection Guide**

PRODUCTION	INDUCTORS	CAPACITORS	DIODES
Surface mount	Coiltronics UP2B-2R2	Sanyo 6TPC100M	Motorola MBRD1035CTL
	Coilcraft DO3316P-222HC	Panasonic EEFUE0J151R	Central CSMH5-20

**Table 4. Component Suppliers**

SUPPLIER	PHONE	FAX
Central	631-435-1110	631-435-1824
Coilcraft	847-639-6400	847-639-1489
Coiltronics	561-241-7876	561-241-9339
Motorola	602-303-5454	602-994-6430
Panasonic	714-373-7939	714-373-7183

## Design Procedure

### Inductor Selection (L1)

The MAX1708's high switching frequency allows the use of a small-size inductor. Use a 2.2µH inductor for 600kHz operation. If the MAX1708 is synchronized at a different frequency, scale the inductor value with the inverse of frequency ( $L_1 = 2.2\mu\text{H} \times 600\text{kHz} / f_{\text{SYNC}}$ ). The PWM design tolerates inductor values within ±25% of this calculated value, so choose the closest standard inductor value. For example, use 3.3µH for 350kHz and 1.5µH for 1MHz).

Inductors with a ferrite core or equivalent are recommended; powder iron cores are not recommended for use at high switching frequencies. Ensure the inductor's saturation rating (the current at which the core begins to saturate and inductance falls) exceeds the

internal current limit. Note that this current may be reduced through SS/LIM if less than the MAX1708's full load current is needed (see *Electrical Characteristics* for ratings). For highest efficiency, use a coil with low DC resistance, preferably under 20mΩ. To minimize radiated noise, use a toroid, pot core, or shielded inductor. See Tables 3 and 4 for a list of recommended components and component suppliers. To calculate the maximum output current (in amperes), use the following equation:

$$I_{\text{OUT(MAX)}} = D' \left( I_{\text{LIM}} - D' \left( \frac{V_{\text{OUT}} + V_{\text{D}} - V_{\text{IN}}}{2 \times f \times L_1} \right) \right)$$

where:

- V<sub>IN</sub> = input voltage
- V<sub>D</sub> = forward voltage drop of the Schottky diode at I<sub>LIM</sub>
- V<sub>OUT</sub> = output voltage
- D' = (V<sub>IN</sub>) / (V<sub>OUT</sub> + V<sub>D</sub>), neglecting switch voltage drop
- f = switching frequency
- L<sub>1</sub> = inductor value
- I<sub>LIM</sub> = minimum value of switch current limit from *Electrical Characteristics* or set by R1 of Figure 1.

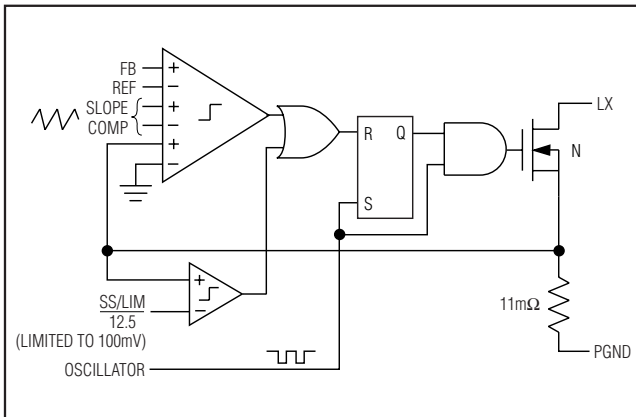

Figure 3. Simplified PWM Controller Functional Diagram

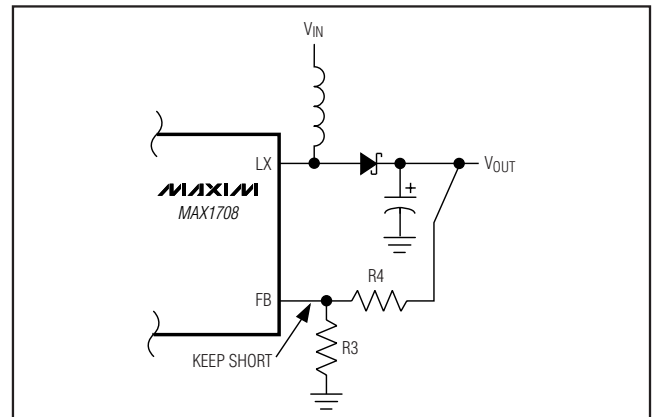

Figure 4. Adjustable Output Voltage

# High-Frequency, High-Power, Low-Noise, Step-Up DC-DC Converter

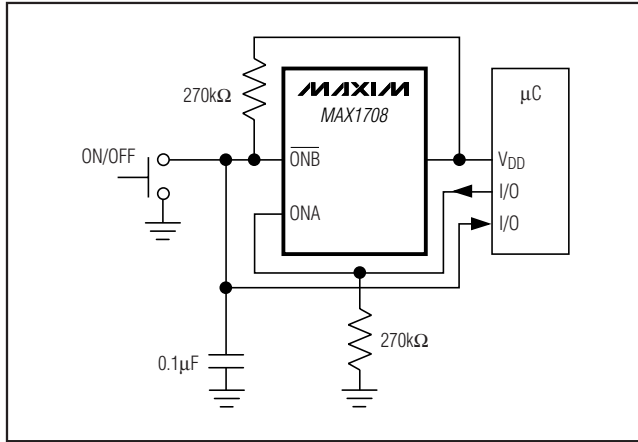

Figure 5. Momentary Pushbutton On-Off Switch

## Diode Selection (D1)

The MAX1708's high switching frequency demands a high-speed rectifier. Use Schottky diodes (Table 3). The diode's current rating must exceed the maximum load current, and its breakdown voltage must exceed  $V_{OUT}$ . The diode must be placed within 10mm of the LX switching node and the output filter capacitor. The diode also must be able to dissipate the power calculated by the following equation:

$$P_{DIODE} = I_{OUT} \times V_D$$

where  $I_{OUT}$  is the average load current and  $V_D$  is the diode forward voltage at the peak switch current.

## Capacitor Selection

### Input Bypass Capacitor (C1)

A 150μF, low-ESR input capacitor will reduce peak currents and reflected noise due to inductor current ripple. Lower ESR allows for lower input ripple current, but combined ESR values up to 100mΩ are acceptable. Smaller ceramic capacitors may also be used for light loads or in applications that can tolerate higher input current ripple.

### Output Filter Capacitor (C2)

The output filter capacitor ESR must be kept under 30mΩ for stable operation. Polymer capacitors of 150μF (Panasonic EEFUE0J151R) typically exhibit 10mΩ of ESR. This translates to approximately 35mV of output ripple at 3.5A switch current. Bypass the MAX1708 IC supply input (OUT) with a 0.1μF ceramic capacitor to GND and a 2Ω series resistor (R2, as shown in Figure 1).

## MAX1708 IC Power Dissipation

The major components of MAX1708 dissipated power are switch conduction loss ( $P_{SW}$ ), capacitive loss ( $P_{CAP}$ ), and switch transition loss ( $P_{TRAN}$ ). Numerical examples provided in brackets ( { } ) correspond to the following condition:

$$\{V_{IN} = 3.3V, V_{OUT} = 5V, V_D = 0.5V, I_{OUT} = 2A\}$$

An important parameter to compute the power dissipated in the MAX1708 is the approximate peak switch current ( $I_{SW}$ ):

$$I_{SW} = \frac{I_{OUT}}{D'} \{3.33A\}$$

$$D' = \frac{V_{IN}}{V_{OUT} + V_D} \{0.6\}$$

$$P_D = P_{SW} + P_{CAP} + P_{TRAN} \{0.472W\}$$

$$P_{SW} = (1 - D') I_{SW}^2 \times R_{SW} \{0.353W\}$$

$$P_{CAP} = (C_{DIO} + C_{DSW} + C_{GSW}) (V_{OUT} + V_D)^2 f \{0.045W\}$$

$$P_{TRAN} = (V_{OUT} + V_D) I_{SW} \times t_{SW} \times f / 3 \{0.073W\}$$

where:

$R_{SW}$  = switch resistance {80mΩ}

$C_{DIO}$  = catch-diode capacitance {500pF}

$C_{DSW}$  = switch drain capacitance {1250pF}

$C_{GSW}$  = switch gate capacitance {750pF}

$f$  = switching frequency {600kHz}

$t_{SW}$  = switch turn-on or turn-off time {20ns}

## Applications Information

### Using a Momentary On/Off Switch

A momentary pushbutton switch can be used to turn the MAX1708 on and off. As shown in Figure 5, when ONA is pulled low and  $\overline{ONB}$  is pulled high, the device is off. When the momentary switch is pressed,  $\overline{ONB}$  is pulled low and the regulator turns on. The switch should be on long enough for the microcontroller to exit reset. The controller issues a logic high to ONA, which guarantees that the device will stay on regardless of the subsequent switch state. To turn the regulator off, depress the switch long enough for the controller to read the switch status and pull ONA low. When the switch is released,  $\overline{ONB}$  pulls high and the regulator turns off.

# High-Frequency, High-Power, Low-Noise, Step-Up DC-DC Converter

MAX1708

## Layout Considerations

Due to high inductor current levels and fast switching waveforms, proper PC board layout is essential. Protect sensitive analog grounds by using a star ground configuration. Connect PGND, the input bypass capacitor ground lead, and the output filter capacitor ground lead to a single point (star ground configuration). In addition, minimize trace lengths to reduce stray capacitance and trace resistance, especially from the LX pins to the catch diode (D1) and output capacitor (C2) to PGND pins. If an external resistor-divider is used to set the output voltage (Figure 4), the trace from FB to the resistors must be extremely short and must be shielded from switching signals, such as CLK or LX. To optimize package power dissipation and minimize device heating under heavy loads, expand PC trace area connected to the three PGND pins as much as the layout can allow. This is best accomplished with a large PGND plane on the surface of the board. Also note that outer-layer ground plane area beneath the device provides little heat-sinking benefit. If an outer-layer ground plane is not feasible, the PGND pins should be connected to the inner-layer ground plane with multiple vias (at least three vias per pin is recommended). Since the purpose of these vias is to optimize thermal conductivity to the inner ground plane, be sure that the vias have no gaps in their connections to the ground plane. Refer to a layout example in the MAX1708EVKIT data sheet.

## Chip Information

SUBSTRATE: GND  
PROCESS: BiCMOS

## Package Information

For the latest package outline information and land patterns, go to [www.maxim-ic.com/packages](http://www.maxim-ic.com/packages). Note that a "+", "#", or "-" in the package code indicates RoHS status only. Package drawings may show a different suffix character, but the drawing pertains to the package regardless of RoHS status.

PACKAGE TYPE	PACKAGE CODE	OUTLINE NO.	LAND PATTERN NO.
16 QSOP	E16+1	<a href="#">21-0055</a>	<a href="#">90-0167</a>

# High-Frequency, High-Power, Low-Noise, Step-Up DC-DC Converter

## Revision History

REVISION NUMBER	REVISION DATE	DESCRIPTION	PAGES CHANGED
0	7/01	Initial release	—
1	11/10	Updated the N-Channel Current Limit parameter in the <i>Electrical Characteristics</i> , corrected the equation in the <i>Setting the Output Voltage</i> section	3, 10

Maxim cannot assume responsibility for use of any circuitry other than circuitry entirely embodied in a Maxim product. No circuit patent licenses are implied. Maxim reserves the right to change the circuitry and specifications without notice at any time.

14 **Maxim Integrated Products, 120 San Gabriel Drive, Sunnyvale, CA 94086 408-737-7600**

## Looking for pricing, stock, or lifecycle information?

Click below to explore more details on WIN SOURCE:

- ⊖ [View MAX1708EEE+T on WIN SOURCE](#)
- ⊖ [Maxim Integrated Information](#)

## Optimize Your Supply Chain with WIN SOURCE Solutions

- ✓ Global Sourcing Solution
- ✓ Obsolete Management
- ✓ Cost Control Management
- ✓ Shortage Management
- ✓ Alternative Solution
- ✓ Excess Inventory Management