



**THE DATASHEET OF
MAX1715EEI+**



Ultra-High Efficiency, Dual Step-Down Controller for Notebook Computers

General Description

The MAX1715 PWM controller provides the high efficiency, excellent transient response, and high DC output accuracy needed for stepping down high-voltage batteries to generate low-voltage CPU core, I/O, and chipset RAM supplies in notebook computers.

Maxim's proprietary Quick-PWM™ quick-response, constant-on-time PWM control scheme handles wide input/output voltage ratios with ease and provides 100ns "instant-on" response to load transients while maintaining a relatively constant switching frequency.

The MAX1715 achieves high efficiency at a reduced cost by eliminating the current-sense resistor found in traditional current-mode PWMs. Efficiency is further enhanced by its ability to drive very large synchronous-rectifier MOSFETs.

Single-stage buck conversion allows this device to directly step down high-voltage batteries for the highest possible efficiency. Alternatively, two-stage conversion (stepping down the +5V system supply instead of the battery) at a higher switching frequency allows the minimum possible physical size.

The MAX1715 is intended for CPU core, chipset, DRAM, or other low-voltage supplies as low as 1V. The MAX1715 is available in a 28-pin QSOP package. For applications requiring VID compliance or DAC control of output voltage, refer to the MAX1710/MAX1711 data sheet. For a single-output version, refer to the MAX1714 data sheet.

Applications

Notebook Computers
CPU Core Supply
Chipset/RAM Supply as Low as 1V
1.8V and 2.5V I/O Supply

Pin Configuration appears at end of data sheet.

Quick-PWM is a trademark of Maxim Integrated Products.

Features

- ◆ Ultra-High Efficiency
- ◆ No Current-Sense Resistor (lossless I_{LIMIT})
- ◆ Quick-PWM with 100ns Load-Step Response
- ◆ 1% V_{OUT} Accuracy over Line and Load
- ◆ Dual-Mode Fixed 1.8V/3.3V/Adj or 2.5V/Adj Outputs
- ◆ Adjustable 1V to 5.5V Output Range
- ◆ 2V to 28V Battery Input Range
- ◆ 200/300/420/540kHz Nominal Switching Frequency
- ◆ Over/Undervoltage Protection
- ◆ 1.7ms Digital Soft-Start
- ◆ Drives Large Synchronous-Rectifier FETs
- ◆ Power-Good Indicator

Ordering Information

PART	TEMP RANGE	PIN-PACKAGE
MAX1715EEI	-40°C to +85°C	28 QSOP
MAX1715EEI+	-40°C to +85°C	28 QSOP

+ Denotes lead-free package.

Minimal Operating Circuit

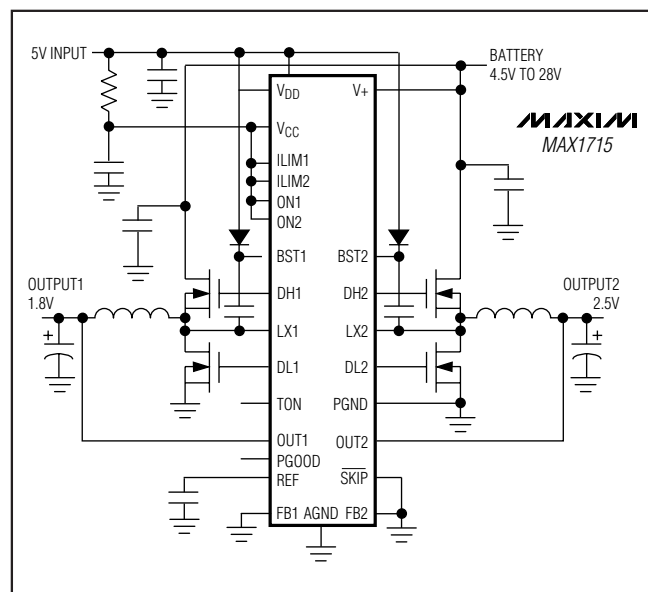

Ultra-High Efficiency, Dual Step-Down Controller for Notebook Computers

ABSOLUTE MAXIMUM RATINGS

V ₊ to AGND	-0.3 to +30V
V _{DD} , V _{CC} to AGND	-0.3V to +6V
PGND to AGND or V _{CC} to V _{DD}	±0.3V
PGOOD, OUT ₋ to AGND	-0.3V to +6V
ILIM ₋ , FB ₋ , REF, SKIP, TON, ON ₋ to AGND	-0.3V to (V _{DD} + 0.3V)
DL ₋ to PGND	-0.3V to (V _{DD} + 0.3V)
BST ₋ to AGND	-0.3V to +36V
DH1 to LX1	-0.3V to (BST1 + 0.3V)
DH2 to LX2	-0.3V to (BST2 + 0.3V)

LX1 to BST1	-6V to +0.3V
LX2 to BST2	-6V to +0.3V
REF Short Circuit to AGND	Continuous
Continuous Power Dissipation (T _A = +70°C)	28-Pin QSOP (derate 8.0mW/°C above +70°C).....640mW/°C
Operating Temperature Range	-40°C to +85°C
Junction Temperature	+150°C
Storage Temperature Range	-65°C to +150°C
Lead Temperature (soldering, 10s)	+300°C

Stresses beyond those listed under "Absolute Maximum Ratings" may cause permanent damage to the device. These are stress ratings only, and functional operation of the device at these or any other conditions beyond those indicated in the operational sections of the specifications is not implied. Exposure to absolute maximum rating conditions for extended periods may affect device reliability.

ELECTRICAL CHARACTERISTICS

(Circuit of Figure 1, 4A components from Table 1, V_{CC} = V_{DD} = +5V, SKIP = AGND, V₊ = 15V, T_A = 0°C to +85°C, unless otherwise noted.) (Note 1)

PARAMETER	CONDITIONS		MIN	TYP	MAX	UNITS	
Input Voltage Range	Battery voltage, V ₊		2		28	V	
	V _{DD} , V _{CC}		4.5		5.5		
Output 1 Error Comparator Threshold (DC Output Voltage Accuracy) (Note 2)	V ₊ = 2V to 28V, SKIP = V _{CC} , T _A = +25°C I _{LOAD} = 0 to 4A	FB1 = OUT1	0.99	1.00	1.01	V	
		FB1 = AGND	1.782	1.8	1.818		
		FB1 = V _{CC}	3.267	3.3	3.333		
Output 1 Error Comparator Threshold (DC Output Voltage Accuracy) (Note 2)	V ₊ = 2V to 28V, SKIP = V _{CC} , T _A = 0°C to +85°C I _{LOAD} = 0 to 4A	FB1 = OUT1	0.985	1.00	1.105	V	
		FB1 = AGND	1.773	1.8	1.827		
		FB1 = V _{CC}	3.250	3.3	3.350		
Output 2 Error Comparator Threshold (DC Output Voltage Accuracy) (Note 2)	V ₊ = 2V to 28V, SKIP = V _{CC} , T _A = +25°C I _{LOAD} = 0 to 4A	FB2 = OUT2	0.99	1.00	1.01	V	
		FB2 = GND	2.475	2.5	2.525		
Output 2 Error Comparator Threshold (DC Output Voltage Accuracy) (Note 2)	V ₊ = 2V to 28V, SKIP = V _{CC} , T _A = 0°C to +85°C I _{LOAD} = 0 to 4A	FB2 = OUT2	0.985	1.00	1.105	V	
		FB2 = GND	2.463	2.5	2.538		
Load Regulation Error	I _{LOAD} = 0 to 4A, each output			0.4		%	
Line Regulation Error	V _{CC} = 4.5V to 5.5V, V ₊ = 4.5V to 28V			0.2		%	
Output Voltage Range	Adjustable mode, each output		1		5.5	V	
OUT ₋ Input Resistance	FB ₋ = AGND		75k			Ω	
FB ₋ Input Bias Current	V _{OUT-} = AGND		-0.1			0.1	μA
Soft-Start Ramp Time	Rising edge of ON ₋ to full current limit		1.7			ms	
On-Time (PWM1)	V ₊ = 24V, OUT1 = 2V	TON = GND	112	136	160	ns	
		TON = REF	142	173	205		
		TON = open	210	247	280		
		TON = V _{DD}	300	353	407		
On-Time (PWM2)	V ₊ = 24V, OUT2 = 2V	TON = GND	154	182	215	ns	
		TON = REF	198	234	270		
		TON = open	292	336	380		
		TON = V _{DD}	420	484	550		

Ultra-High Efficiency, Dual Step-Down Controller for Notebook Computers

MAX1715

ELECTRICAL CHARACTERISTICS (continued)

(Circuit of Figure 1, 4A components from Table 1, $V_{CC} = V_{DD} = +5V$, $\overline{SKIP} = AGND$, $V_+ = 15V$, $T_A = 0^\circ C$ to $+85^\circ C$, unless otherwise noted.) (Note 1)

PARAMETER	CONDITIONS	MIN	TYP	MAX	UNITS
Minimum Off-Time	(Note 3)		400	500	ns
Quiescent Battery Current (V+)			25	70	μA
Quiescent Supply Current ($V_{CC} + V_{DD}$)	FB1 and FB2 forced above the regulation point		1100	1600	μA
Shutdown Supply Current ($V_{CC} + V_{DD}$)	ON1 = ON2 = 0		<1	5	μA
Shutdown Supply Current (V+)	ON1 = ON2 = 0		<1	5	μA
Reference Voltage	No external REF load	1.98	2	2.02	V
Reference Load Regulation	$I_{REF} = 0$ to $50\mu A$		2	0.01	V
REF Sink Current	REF in regulation	10			μA
REF Fault Lockout Voltage	Falling edge, hysteresis = 40mV		1.6		V
Overshoot Trip Threshold	With respect to error comparator threshold	8.5	10.5	13	%
Overshoot Fault Propagation Delay	FB_ forced 2% above trip threshold		1.5		μs
Output Undervoltage Threshold	With respect to error comparator threshold	60	70	80	%
Output Undervoltage Lockout Time	From ON_ signal going high	10	20	30	ms
Current-Limit Threshold (Positive Direction, Fixed)	PGND - LX_, $I_{LIM} = V_{CC}$	75	100	125	mV
Current-Limit Threshold (Positive Direction, Adjusted)	PGND - LX_, I_{LIM} resistor = 100k Ω	40	50	60	mV
	PGND - LX_, I_{LIM} resistor = 400k Ω	160	200	240	
Current-Limit Threshold (Negative Direction)	PGND - LX_, $T_A = +25^\circ C$, $I_{LIM} = V_{CC}$	-145	-120	-95	mV
Current-Limit Threshold, Zero Crossing	PGND - LX_, $\overline{SKIP} = AGND$	-5	3	10	mV
Thermal Shutdown Threshold	Hysteresis = $10^\circ C$		150		$^\circ C$
V_{CC} Undervoltage Lockout Threshold	Rising edge, hysteresis = 20mV, PWM disabled below this level	4.1		4.4	V
DH Gate Driver On-Resistance	BST - LX forced to 5V		1.5	5	Ω
DL Gate Driver On-Resistance (pull-up)	DL, high state		1.5	5	Ω
DL Gate Driver On-Resistance (pull-down)	DL, low state		0.6	2.5	Ω
DH Gate Driver Source/Sink Current	DH forced to 2.5V, BST_ - LX_ forced to 5V		1		A
DL Gate Driver Source Current	DL forced to 2.5V		1		A
DL Gate Driver Sink Current	DL forced to 2.5V		3		A
Dead Time	DL rising		35		ns
	DH rising		26		
Logic Input High Voltage	ON_, \overline{SKIP}	2.4			V
Logic Input Low Voltage	ON_, \overline{SKIP}			0.8	V

Ultra-High Efficiency, Dual Step-Down Controller for Notebook Computers

ELECTRICAL CHARACTERISTICS (continued)

(Circuit of Figure 1, 4A components from Table 1, $V_{CC} = V_{DD} = +5V$, $\overline{SKIP} = AGND$, $V_+ = 15V$, $T_A = 0^\circ C$ to $+85^\circ C$, unless otherwise noted.) (Note 1)

PARAMETER	CONDITIONS	MIN	TYP	MAX	UNITS
Logic Input Current	\overline{SKIP} , to deactivate OVP circuitry	-5		-1	mA
TON Threshold	V_{CC} level	$V_{CC} - 0.4$			V
	Float level	3.15		3.85	
	REF level	1.65		2.35	
	AGND level			0.5	
Logic Input Current	TON (0 or V_{CC})	-3		3	μA
Logic Input Current	ON_, \overline{SKIP} (0 or V_{CC})	-1		1	μA
PGOOD Trip Threshold	Measured at FB_, with respect to error comparator threshold, no load	-8	-5.5	-4	%
PGOOD Propagation Delay	Falling edge, FB_ forced 2% below PGOOD trip threshold		1.5		μs
PGOOD Output Low Voltage	$I_{SINK} = 1mA$		0.1	0.4	V
PGOOD Leakage Current	High state, forced to 5.5V			1	μA

ELECTRICAL CHARACTERISTICS

(Circuit of Figure 1, 4A components from Table 1, $V_{CC} = V_{DD} = +5V$, $\overline{SKIP} = AGND$, $V_+ = 15V$, $T_A = -40^\circ C$ to $+85^\circ C$, unless otherwise noted.) (Note 1)

PARAMETER	CONDITIONS	MIN	TYP	MAX	UNITS	
Input Voltage Range	Battery voltage, V_+	2		28	V	
	V_{DD} , V_{CC}	4.5		5.5		
Output 1 Error Comparator Threshold (DC Output Voltage Accuracy) (Note 2)	$V_+ = 2V$ to $28V$, $\overline{SKIP} = V_{CC}$	FB1 = OUT1	0.98	1.00	1.02	V
		FB1 = AGND	1.764	1.8	1.836	
		FB1 = V_{CC}	3.234	3.3	3.372	
Output 2 Error Comparator Threshold (DC Output Voltage Accuracy) (Note 2)	$V_+ = 4.5V$ to $28V$, $\overline{SKIP} = V_{CC}$	FB2 = OUT2	0.98	1.00	1.02	V
		FB2 = GND	2.45	2.5	2.55	
On-Time (PWM1)	$V_+ = 24V$, OUT1 = 2V	TON = GND	112	136	160	ns
		TON = REF	142	173	205	
		TON = open	210	247	280	
		TON = V_{DD}	300	353	407	
On-Time (PWM2)	$V_+ = 24V$, OUT2 = 2V	TON = GND	154	182	215	ns
		TON = REF	198	234	270	
		TON = open	292	336	380	
		TON = V_{DD}	420	484	550	
Minimum Off-Time	(Note 3)		400	500	ns	

Ultra-High Efficiency, Dual Step-Down Controller for Notebook Computers

MAX1715

ELECTRICAL CHARACTERISTICS (continued)

(Circuit of Figure 1, 4A components from Table 1, $V_{CC} = V_{DD} = +5V$, $\overline{SKIP} = AGND$, $V_+ = 15V$, $T_A = -40^\circ C$ to $+85^\circ C$, unless otherwise noted.) (Note 1)

PARAMETER	CONDITIONS	MIN	TYP	MAX	UNITS
Quiescent Battery Current (V_+)			25	70	μA
Quiescent Supply Current ($V_{CC} + V_{DD}$)	FB1 and FB2 forced above the regulation point		1100	1600	μA
Reference Voltage	No external REF load	1.97	2	2.03	V
Reference Load Regulation	$I_{REF} = 0$ to $50\mu A$			0.01	V
Overvoltage Trip Threshold	With respect to error comparator threshold	10	12.5	15	%
Output Undervoltage Threshold	With respect to error comparator threshold	60	70	80	%
Current-Limit Threshold (positive direction, fixed)	PGND - LX ₋ , $I_{LIM} = V_{CC}$	75	100	125	mV
Current-Limit Threshold (positive direction, adjusted)	PGND - LX ₋ , I_{LIM} resistor = $100k\Omega$	32	50	62	mV
	PGND - LX ₋ , I_{LIM} resistor = $400k\Omega$	160	200	240	
Thermal Shutdown Threshold	Hysteresis = $10^\circ C$		150		$^\circ C$
V_{CC} Undervoltage Lockout Threshold	Rising edge, hysteresis = $20mV$, PWM disabled below this level	4.1		4.4	V
Logic Input High Voltage	ON ₋ , \overline{SKIP}	2.4			V
Logic Input Low Voltage	ON ₋ , \overline{SKIP}			0.8	V
Logic Input Current	\overline{SKIP} , to deactivate OVP circuitry	-5		-1	mA

Note 1: Specifications to $-40^\circ C$ are guaranteed by design, and not production tested.

Note 2: When the inductor is in continuous conduction, the output voltage will have a DC regulation higher than the trip level by 50% of the ripple. In discontinuous conduction ($\overline{SKIP} = AGND$, light load) the output voltage will have DC regulation higher than the trip level by approximately 1.5% due to slope compensation.

Note 3: On-time and off-time specifications are measured from the 50% point at the DH pin with LX = PGND, $V_{BST} = 5V$. Actual in-circuit times may differ due to MOSFET switching speeds.

Typical Operating Characteristics

(Circuit of Figure 1, components from Table 1, $V_{IN} = +15V$, $\overline{SKIP} = AGND$, TON = unconnected, $T_A = +25^\circ C$, unless otherwise noted.)

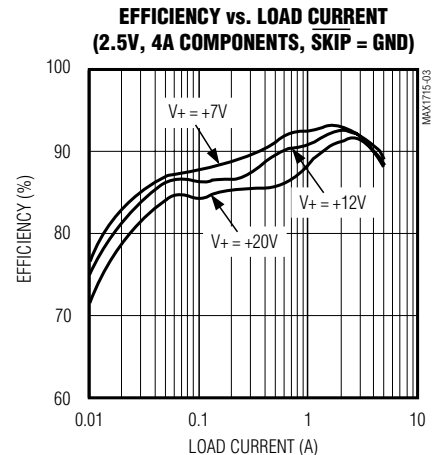
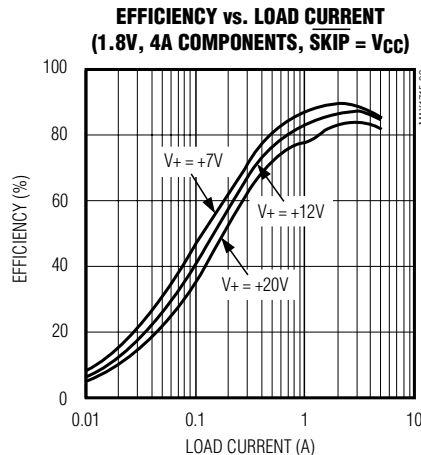
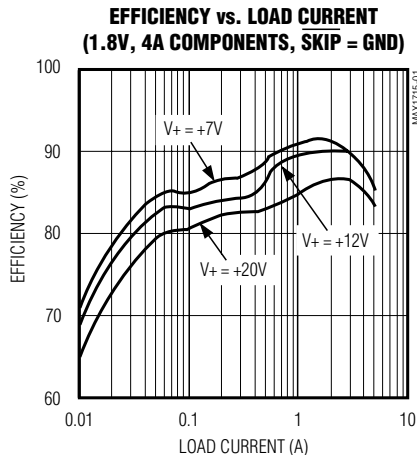

Ultra-High Efficiency, Dual Step-Down Controller for Notebook Computers

Typical Operating Characteristics (continued)

(Circuit of Figure 1, components from Table 1, $V_{IN} = +15V$, $\overline{SKIP} = AGND$, $T_{ON} = \text{unconnected}$, $T_A = +25^\circ C$, unless otherwise noted.)

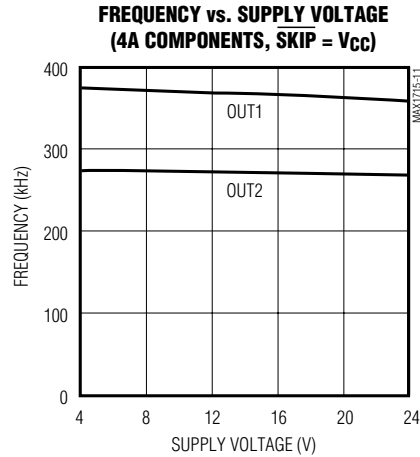
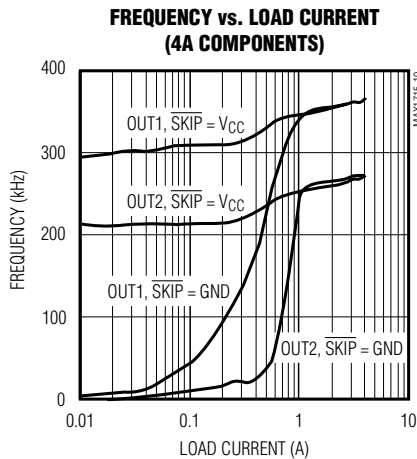
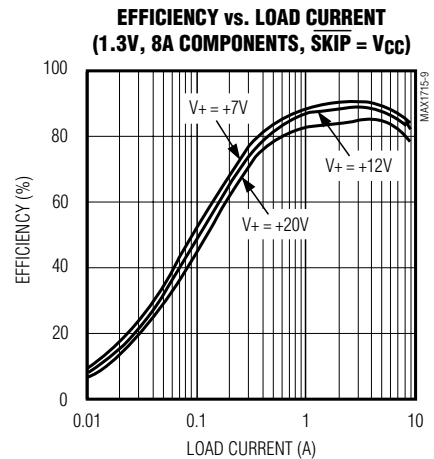
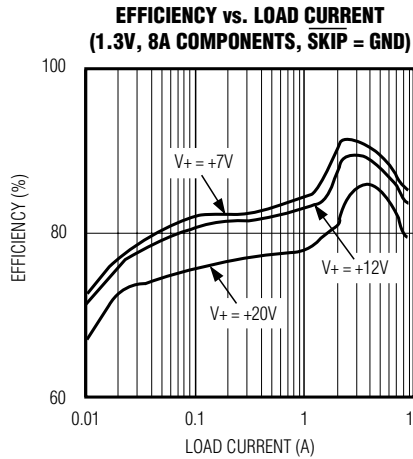
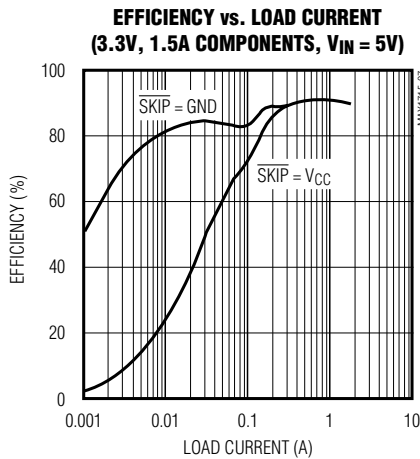
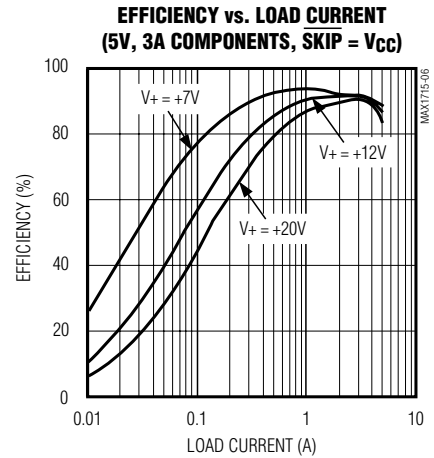
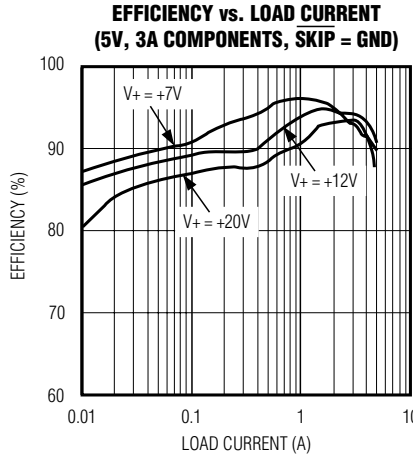
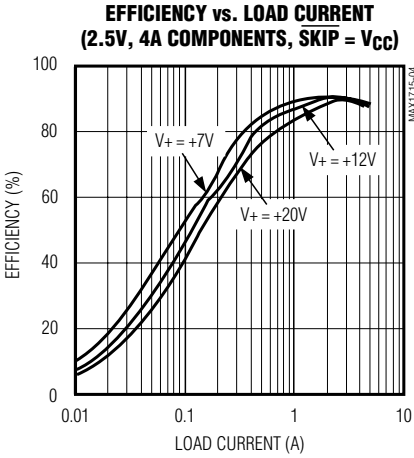

Ultra-High Efficiency, Dual Step-Down Controller for Notebook Computers

MAX1715

Typical Operating Characteristics (continued)

(Circuit of Figure 1, components from Table 1, $V_{IN} = +15V$, $\overline{SKIP} = AGND$, $T_{ON} = \text{unconnected}$, $T_A = +25^\circ C$, unless otherwise noted.)

**FREQUENCY vs. TEMPERATURE
(2.5V, 4A COMPONENTS, SKIP = HIGH)**

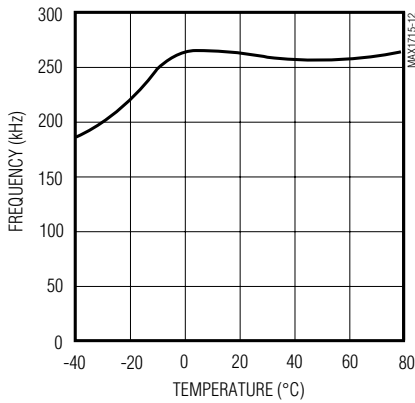

**NO-LOAD SUPPLY CURRENT vs. INPUT VOLTAGE
(OUT1 = 1.8V, 4A COMPONENTS;
OUT2 = 2.5V, 4A COMPONENTS; SKIP = GND)**

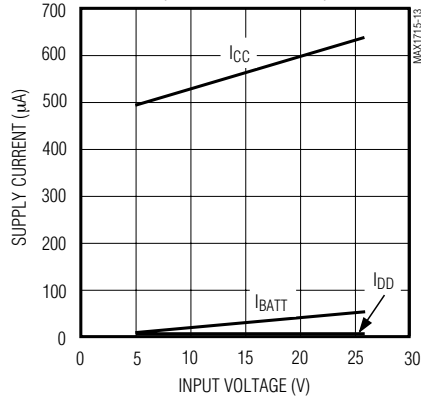

**NO-LOAD SUPPLY CURRENT vs. INPUT VOLTAGE
(OUT1 = 1.8V, 4A COMPONENTS;
OUT2 = 2.5V, 4A COMPONENTS; SKIP = VCC)**

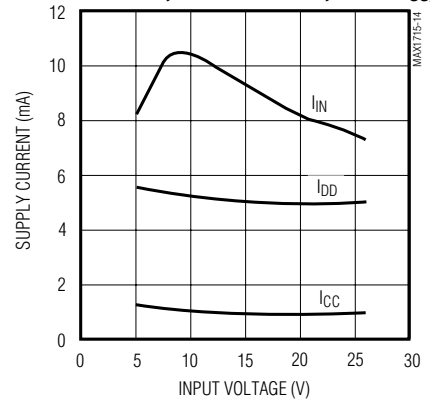

**LOAD-TRANSIENT RESPONSE
(2.5V, 4A COMPONENTS, SKIP = GND)**

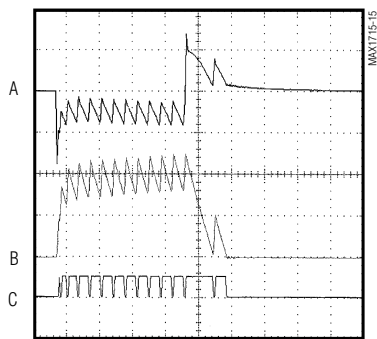

A = V_{OUT} , AC-COUPLED, 100mV/div
B = INDUCTOR CURRENT, 2A/div
C = DL, 10V/div

**START-UP WAVEFORM
(2.5V, 4A COMPONENTS, ACTIVE LOAD)**

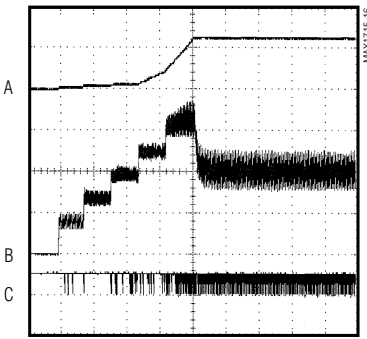

A = V_{OUT} , 2V/div
B = INDUCTOR CURRENT, 2A/div
C = DL, 10V/div

**LOAD-TRANSIENT RESPONSE
(1.3V, 8A COMPONENTS, SKIP = GND)**

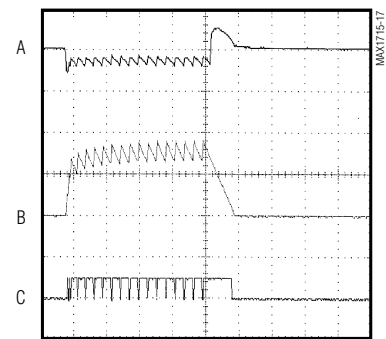

A = V_{OUT} , AC-COUPLED, 100mV/div
B = INDUCTOR CURRENT, 5A/div
C = DL, 10V/div

**OUTPUT OVERLOAD WAVEFORM
(2.5V, 4A COMPONENTS, SKIP = GND)**

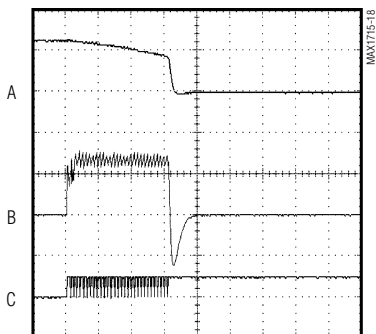

A = V_{OUT} , 2V/div
B = INDUCTOR CURRENT, 5A/div
C = DL, 10V/div

**SHUTDOWN WAVEFORM
(2.5V, 4A COMPONENTS, SKIP = GND)**

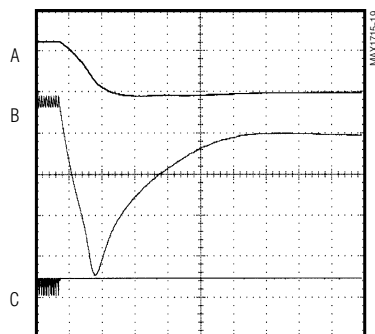

A = V_{OUT} , 2V/div
B = INDUCTOR CURRENT, 5A/div
C = DL, 10V/div

Ultra-High Efficiency, Dual Step-Down Controller for Notebook Computers

Pin Description

PIN	NAME	FUNCTION		
1	OUT1	Output Voltage Connection for the OUT1 PWM. Connect directly to the junction of the external inductor and output filter capacitors. OUT1 senses the output voltage to determine the on-time and also serves as the feedback input in fixed-output modes.		
2	FB1	Feedback Input for OUT1. Connect to AGND for 1.8V fixed output or to V _{CC} for 3.3V fixed output, or connect to a resistor-divider from OUT1 for an adjustable output.		
3	ILIM1	Current-Limit Threshold Adjustment for OUT1. The LX1-PGND current-limit threshold defaults to +100mV if ILIM1 is connected to V _{CC} . Or, connect an external resistor to AGND to adjust the limit. A precision 5μA pull-up current through R _{EXT} sets the threshold from 50mV to 200mV. The voltage on the pin is 10 times the current-limit voltage. Choose R _{EXT} equal to 2kΩ per mV of current-limit threshold (100kΩ to 400kΩ).		
4	V+	Battery Voltage Sense Connection. Connect to the input power source. V+ is used only to set the PWM one-shot timing.		
5	TON	On-Time Selection Control Input. This is a four-level input used to determine DH _{on} -time. The TON table below is for V _{IN} = 24V, V _{OUT1} = 1.8V, V _{OUT2} = 2.5V condition.		
		TON	Frequency (OUT1) (kHz)	Frequency (OUT2) (kHz)
		AGND	620	460
		REF	485	355
		Open	345	255
V _{CC}	235	170		
6	SKIP	Pulse-Skipping Control Input. Connect to V _{CC} for low-noise forced-PWM mode. Connect to AGND to enable pulse-skipping operation.		
7	PGOOD	Power-Good Open-Drain Output. PGOOD is low when either FB _n input is more than 5.5% below the normal regulation point (typ).		
8	AGND	Analog Ground		
9	REF	+2.0V Reference Voltage Connection. Bypass to AGND with 0.22μF (min) capacitor. Can supply 50μA for external loads.		
10	ON1	OUT1 ON/OFF Control Input. Drive to AGND to turn OUT1 off. Drive to V _{CC} to turn OUT1 on.		
11	ON2	OUT2 ON/OFF Control Input. Drive to AGND to turn OUT2 off. Drive to V _{CC} to turn OUT2 on.		
12	ILIM2	Current-Limit Threshold Adjustment for OUT2. The LX2-PGND current-limit threshold defaults to +100mV if ILIM2 is connected to V _{CC} . Or, connect an external resistor to AGND to adjust the limit. A precision 5μA pull-up current through R _{EXT} sets the threshold from 50mV to 200mV. The voltage on the pin is 10 times the current-limit voltage. Choose R _{EXT} equal to 2kΩ per mV of current-limit threshold (100kΩ to 400kΩ).		
13	FB2	Feedback Input for OUT2. Connect to AGND for 2.5V fixed output, or connect to a resistor-divider from OUT2 for an adjustable output.		
14	OUT2	Output Voltage Connection for the OUT2 PWM. Connect directly to the junction of the external inductor and output filter capacitors. OUT2 senses the output voltage to determine the on-time and also serves as the feedback input in fixed-output mode.		
15, 23, 28	N.C.	No Connection. These pins are not connected to any internal circuitry. Connect the N.C. pins to the ground plane to enhance thermal conductivity.		

Ultra-High Efficiency, Dual Step-Down Controller for Notebook Computers

MAX1715

Pin Description (continued)

PIN	NAME	FUNCTION
16	LX2	External Inductor Connection for OUT2. Connect to the switched side of the inductor. LX2 serves as the lower supply voltage rail for the DH2 high-side gate driver and is the positive input to the OUT2 current-limit comparator.
17	DH2	High-Side Gate Driver Output for OUT2. Swings from LX2 to BST2.
18	BST2	Boost Flying Capacitor Connection for OUT2. Connect to an external capacitor and diode according to the Standard Application Circuit (Figure 1). See <i>MOSFET Gate Drivers (DH_L, DL_L)</i> section.
19	DL2	Low-Side Gate-Driver Output for OUT2. DL2 swings from PGND to V _{DD} .
20	V _{DD}	Supply Input for the DL Gate Drivers. Connect to the system supply voltage, +4.5V to +5.5V. Bypass to PGND with a minimum 4.7μF ceramic capacitor.
21	V _{CC}	Analog-Supply Input. Connect to the system supply voltage, +4.5V to +5.5V, with a 20Ω series resistor. Bypass to AGND with a 1μF ceramic capacitor.
22	PGND	Power Ground. Connect directly to the low-side MOSFETs' sources. Serves as the negative input of the current-sense amplifiers.
24	DL1	Low-Side Gate Driver Output for OUT1. DL1 swings PGND to V _{DD} .
25	BST1	Boost Flying Capacitor Connection for OUT1. Connect to an external capacitor and diode according to the Standard Application Circuit (Figure 1). See <i>MOSFET Gate Drivers (DH_L, DL_L)</i> section.
26	DH1	High-Side Gate Driver Output for OUT1. Swings from LX1 to BST1.
27	LX1	External Inductor Connection for OUT1. Connect to the switched side of the inductor. LX1 serves as the lower supply voltage rail for the DH1 high-side gate driver.

Ultra-High Efficiency, Dual Step-Down Controller for Notebook Computers

Table 1. Component Selection for Standard Applications

COMPONENT	2.5V at 4A	1.8V at 4A	5V at 3A	1.3V at 8A	3.3V at 1.5A
Input Range	7V to 20V	7V to 20V	7V to 20V	7V to 20V	4.75V to 5.5V
Frequency	255kHz	345kHz	255kHz	255kHz	600kHz
Q1 High-Side MOSFET	Fairchild Semiconductor 1/2 FDS6982A	Fairchild Semiconductor 1/2 FDS6982A	Fairchild Semiconductor 1/2 FDS6990A	International Rectifier IRF7811	International Rectifier 1/2 IRF7301
Q2 Low-Side MOSFET	Fairchild Semiconductor 1/2 FDS6982A	Fairchild Semiconductor 1/2 FDS6982A	Fairchild Semiconductor 1/2 FDS6990A	Fairchild Semiconductor FDS6670A	International Rectifier 1/2 IRF7301
D2 Rectifier	Nihon EP10QY03	Nihon EP10QY03	Nihon EP10QY03	Motorola MBRS340T3	—
L1 Inductor	4.4µH Sumida CDRH125	3.1µH Sumida CDRH125	6.8µH Coiltronics UP2B	1.5µH Sumida CEP125-1R5MC	3.3µH TOKO D73LC
C1 Input Capacitor	10µF, 25V Taiyo Yuden TMK432BJ106KM	10µF, 25V Taiyo Yuden TMK432BJ106KM	10µF, 25V Taiyo Yuden TMK432BJ106KM	(2) 10µF, 25V Taiyo Yuden TMK432BJ106KM	100µF, 10V Sanyo POSCAP 10TPA100M
C2 Output Capacitor	470µF, 4V Sanyo POSCAP 4TPB470M	470µF, 4V Sanyo POSCAP 4TPB470M	330µF, 6V AVX TPSV337M006R 0060	(2) 470µF, 6V Kemet T510X477108M0 06AS	100µF, 10V Sanyo POSCAP 10TPA100M

Table 2. Component Suppliers

MANUFACTURER	USA PHONE	FACTORY FAX [Country Code]
AVX	803-946-0690	[1] 803-626-3123
Central Semiconductor	516-435-1110	[1] 516-435-1824
Coilcraft	847-639-6400	[1] 847-639-1469
Coiltronics	561-241-7876	[1] 561-241-9339
Fairchild Semiconductor	408-822-2181	[1] 408-721-1635
International Rectifier	310-322-3331	[1] 310-322-3332
Kemet	408-986-0424	[1] 408-986-1442
Matsuo	714-969-2491	[1] 714-960-6492
Motorola	602-303-5454	[1] 602-994-6430
Murata	814-237-1431 800-831-9172	[1] 814-238-0490
NIEC (Nihon)	805-867-2555*	[81] 3-3494-7414
Sanyo	619-661-6835	[81] 7-2070-1174
Siliconix	408-988-8000 800-554-5565	[1] 408-970-3950
Sprague	603-224-1961	[1] 603-224-1430
Sumida	847-956-0666	[81] 3-3607-5144
Taiyo Yuden	408-573-4150	[1] 408-573-4159
TDK	847-390-4461	[1] 847-390-4405
TOKO	800-PIK-TOKO	[1] 708-699-1194

*Distributor

The power input and +5V bias inputs can be connected together if the input source is a fixed +4.5V to +5.5V supply. If the +5V bias supply is powered up prior to the battery supply, the enable signal (ON1, ON2) must be delayed until the battery voltage is present to ensure start-up. The +5V bias supply must provide V_{CC} and gate-drive power, so the maximum current drawn is:

$$I_{BIAS} = I_{CC} + f(QG1 + QG2) = 5mA \text{ to } 30mA \text{ (typ)}$$

where I_{CC} is 1mA typical, f is the switching frequency, and QG1 and QG2 are the MOSFET data sheet total gate-charge specification limits at V_{GS} = 5V.

Free-Running, Constant-On-Time PWM Controller with Input Feed-Forward

The Quick-PWM control architecture is a pseudo-fixed-frequency, constant-on-time current-mode type with voltage feed-forward (Figure 3). This architecture relies on the output filter capacitor's ESR to act as the current-sense resistor, so the output ripple voltage provides the PWM ramp signal. The control algorithm is simple: the high-side switch on-time is determined solely by a one-shot whose period is inversely proportional to input voltage and directly proportional to output voltage. Another one-shot sets a minimum off-time (400ns typ). The on-time one-shot is triggered if the error comparator is low, the low-side switch current is below the

Ultra-High Efficiency, Dual Step-Down Controller for Notebook Computers

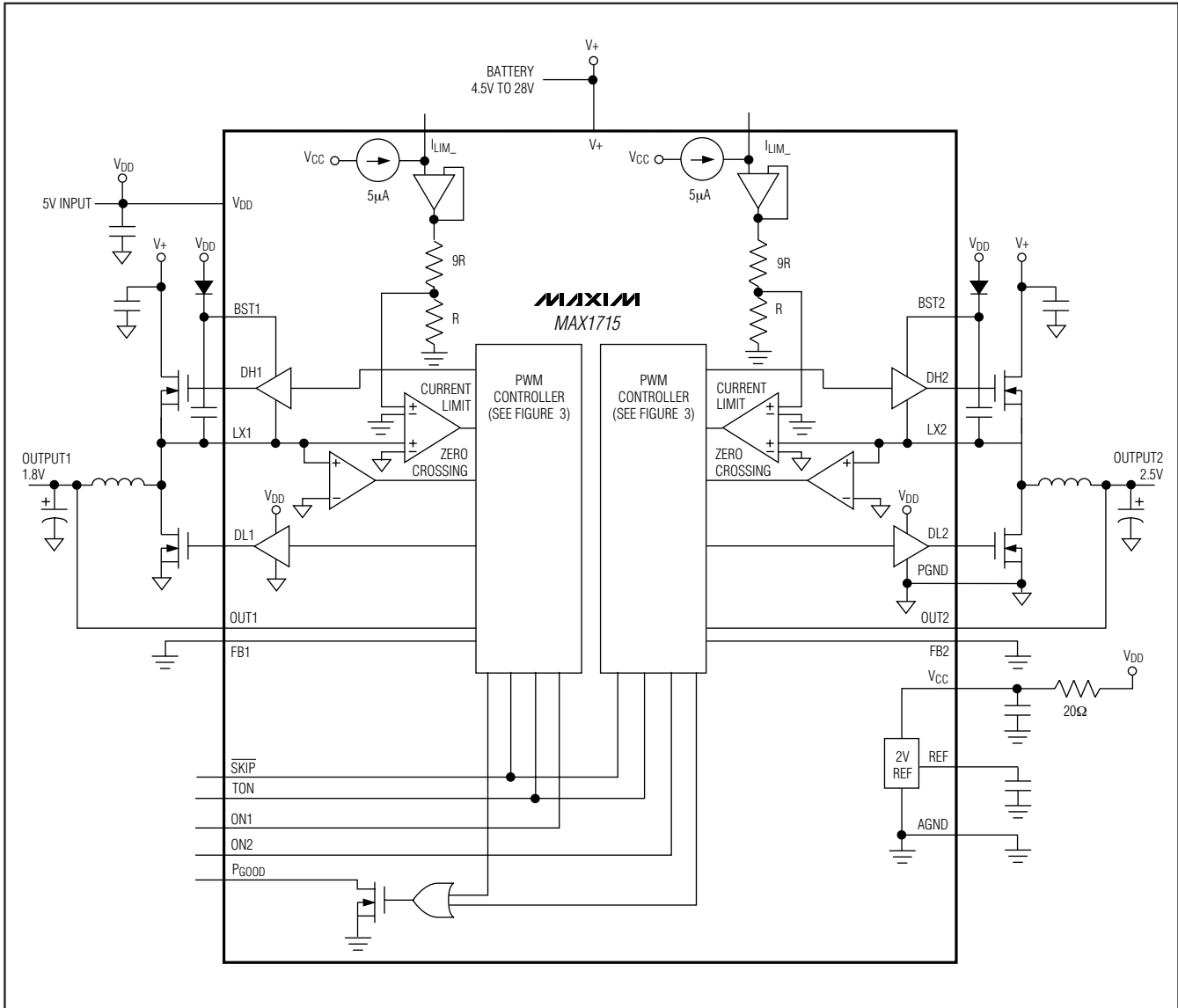

Figure 2. Functional Diagram

current-limit threshold, and the minimum off-time one-shot has timed out.

On-Time One-Shot (TON)

The heart of the PWM core is the one-shot that sets the high-side switch on-time for both controllers. This fast, low-jitter, adjustable one-shot includes circuitry that varies the on-time in response to battery and output voltage. The high-side switch on-time is inversely proportional to the battery voltage as measured by the V+

input, and proportional to the output voltage. This algorithm results in a nearly constant switching frequency despite the lack of a fixed-frequency clock generator. The benefits of a constant switching frequency are twofold: first, the frequency can be selected to avoid noise-sensitive regions such as the 455kHz IF band; second, the inductor ripple-current operating point remains relatively constant, resulting in easy design methodology and predictable output voltage ripple. The on-times for side 1 are set 15% higher than the

Ultra-High Efficiency, Dual Step-Down Controller for Notebook Computers

MAX1715

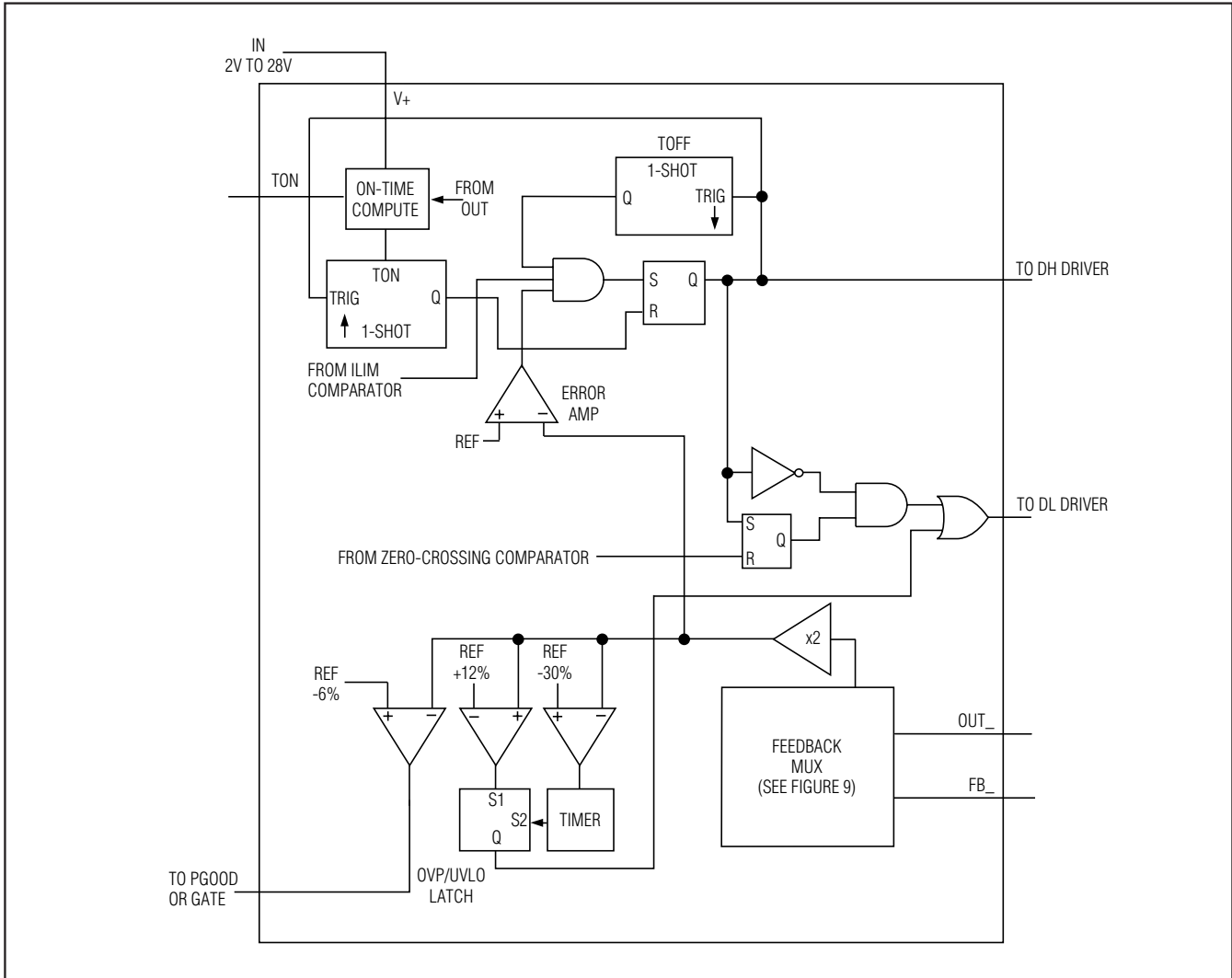

Figure 3. PWM Controller (one side only)

Table 3. Operating Mode Truth Table

ON1	ON2	SKIP	MODE	COMMENTS
0	0	X	SHUTDOWN	Low-power shutdown state. DL = V _{DD} . Clears fault latches.
0	1	X	OUT1 Disable	Disable OUT1. DL1 = V _{DD} . Clears OUT1 fault latches.
1	0	X	OUT2 Disable	Disable OUT2. DL2 = V _{DD} . Clears OUT2 fault latches.
X	X	<-0.3V	No Fault	Disables the output overvoltage and undervoltage fault circuitry.
1	1	V _{DD}	RUN (PWM) Low Noise	Low-Noise operation with no automatic PWM/PFM switchover. Fixed-frequency PWM action is forced regardless of load. Inductor current reverses at light load levels. I _{DD} draw <1.5mA (typ) plus gate-drive current.
1	1	AGND	RUN (PFM/PWM)	Normal operation with automatic PWM/PFM switchover for pulse-skipping at light loads. I _{DD} <1.5mA (typ) plus gate drive current.

X = Don't care

Ultra-High Efficiency, Dual Step-Down Controller for Notebook Computers

Table 4. Frequency Selection Guidelines

NOMINAL FREQUENCY (kHz)	TYPICAL APPLICATION	COMMENTS
200	4-cell Li+ notebook	Use for absolute best efficiency.
300	4-cell Li+ notebook	Considered mainstream by current standards.
420	3-cell Li+ notebook	Useful in 3-cell systems for lighter loads than the CPU core or where size is key.
540	+5V input	Good operating point for compound buck designs or desktop circuits.

nominal frequency setting (200kHz, 300kHz, 420kHz, or 540kHz), while the on-times for side 2 are set 15% lower than nominal. This is done to prevent audio-frequency “beating” between the two sides, which switch asynchronously for each side:

$$\text{On-Time} = K (V_{\text{OUT}} + 0.075\text{V}) / V_{\text{IN}}$$

where K is set by the TON pin-strap connection and 0.075V is an approximation to accommodate for the expected drop across the low-side MOSFET switch. One-shot timing error increases for the shorter on-time settings due to fixed propagation delays; it is approximately $\pm 12.5\%$ at 540kHz and 420kHz nominal settings and $\pm 10\%$ at the two slower settings. This translates to reduced switching-frequency accuracy at higher frequencies (Table 5). Switching frequency increases as a function of load current due to the increasing drop across the low-side MOSFET, which causes a faster inductor-current discharge ramp. The on-times guaranteed in the *Electrical Characteristics* are influenced by switching delays in the external high-side power MOSFET.

Two external factors that influence switching-frequency accuracy are resistive drops in the two conduction loops (including inductor and PC board resistance) and the dead-time effect. These effects are the largest contributors to the change of frequency with changing load current. The dead-time effect increases the effective on-time, reducing the switching frequency as one or both dead times. It occurs only in PWM mode ($\overline{\text{SKIP}} = \text{high}$) when the inductor current reverses at light or negative load currents. With reversed inductor current, the inductor’s EMF causes LX to go high earlier than normal, extending the on-time by a period equal to the low-to-high dead time.

Table 5. Approximate K-Factor Errors

TON SETTING	APPROX K-FACTOR ERROR (%)	MIN V_{IN} AT $V_{\text{OUT}} = 2\text{V}$ (V)	SIDE 1 K FACTOR (μs)	SIDE 2 K FACTOR (μs)
VCC	± 10	2.6	4.24	5.81
OPEN	± 10	2.9	2.96	4.03
REF	± 12.5	3.2	2.08	2.81
GND	± 12.5	3.6	1.63	2.18

For loads above the critical conduction point, the actual switching frequency is:

$$f = \frac{V_{\text{OUT}} + V_{\text{DROP1}}}{t_{\text{ON}}(V_{\text{IN}} + V_{\text{DROP2}})}$$

where V_{DROP1} is the sum of the parasitic voltage drops in the inductor discharge path, including synchronous rectifier, inductor, and PC board resistances; V_{DROP2} is the sum of the resistances in the charging path; and t_{ON} is the on-time calculated by the MAX1715.

Automatic Pulse-Skipping Switchover

In skip mode ($\overline{\text{SKIP}} = \text{low}$), an inherent automatic switchover to PFM takes place at light loads. This switchover is effected by a comparator that truncates the low-side switch on-time at the inductor current’s zero crossing. This mechanism causes the threshold between pulse-skipping PFM and nonskipping PWM operation to coincide with the boundary between continuous and discontinuous inductor-current operation (also known as the “critical conduction” point). For a battery range of 7V to 24V, this threshold is relatively constant, with only a minor dependence on battery voltage.

$$I_{\text{LOAD(SKIP)}} \approx \frac{K \times V_{\text{OUT}}}{2L} \left(\frac{V_{\text{IN}} - V_{\text{OUT}}}{V_{\text{IN}}} \right)$$

where K is the on-time scale factor (Table 5). The load-current level at which PFM/PWM crossover occurs, $I_{\text{LOAD(SKIP)}}$, is equal to 1/2 the peak-to-peak ripple current, which is a function of the inductor value (Figure 4). For example, in the standard application circuit with $V_{\text{OUT1}} = 2.5\text{V}$, $V_{\text{IN}} = 15\text{V}$, and $K = 2.96\mu\text{s}$ (see Table 5), switchover to pulse-skipping operation occurs at $I_{\text{LOAD}} = 0.7\text{A}$ or about 1/6 full load. The crossover point occurs at an even lower value if a swinging (soft-saturation) inductor is used.

The switching waveforms may appear noisy and asynchronous when light loading causes pulse-skipping

Ultra-High Efficiency, Dual Step-Down Controller for Notebook Computers



Figure 4. Pulse-Skipping/Discontinuous Crossover Point

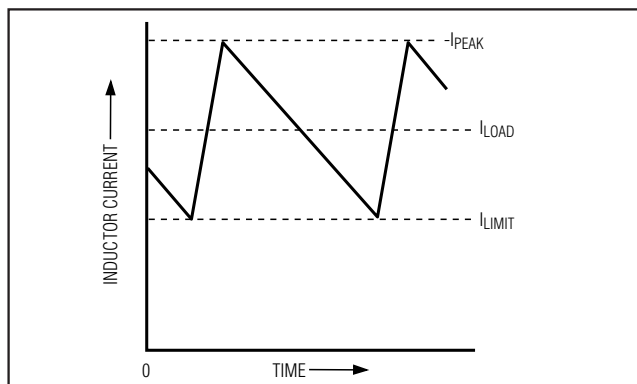

Figure 5. "Valley" Current-Limit Threshold Point

operation, but this is a normal operating condition that results in high light-load efficiency. Trade-offs in PFM noise vs. light-load efficiency are made by varying the inductor value. Generally, low inductor values produce a broader efficiency vs. load curve, while higher values result in higher full-load efficiency (assuming that the coil resistance remains fixed) and less output voltage ripple. Penalties for using higher inductor values include larger physical size and degraded load-transient response (especially at low input voltage levels).

DC output accuracy specifications refer to the trip level of the error. When the inductor is in continuous conduction, the output voltage will have a DC regulation higher than the trip level by 50% of the ripple. In discontinuous conduction (SKIP = AGND, light-loaded), the output voltage will have a DC regulation higher than the trip level by approximately 1.5% due to slope compensation.

Forced-PWM Mode (SKIP = high)

The low-noise, forced-PWM mode (SKIP = high) disables the zero-crossing comparator, which controls the low-side switch on-time. This causes the low-side gate-drive waveform to become the complement of the high-side gate-drive waveform. This in turn causes the inductor current to reverse at light loads as the PWM loop strives to maintain a duty ratio of V_{OUT}/V_{IN} . The benefit of forced-PWM mode is to keep the switching frequency fairly constant, but it comes at a cost: the no-load battery current can be 10mA to 40mA, depending on the external MOSFETs.

Forced-PWM mode is most useful for reducing audio-frequency noise, improving load-transient response, providing sink-current capability for dynamic output voltage adjustment, and improving the cross-regulation of multiple-output applications that use a flyback transformer or coupled inductor.

Current-Limit Circuit (ILIM)

The current-limit circuit employs a unique "valley" current-sensing algorithm that uses the on-state resistance of the low-side MOSFET as a current-sensing element. If the current-sense signal is above the current-limit threshold, the PWM is not allowed to initiate a new cycle (Figure 5). The actual peak current is greater than the current-limit threshold by an amount equal to the inductor ripple current. Therefore, the exact current-limit characteristic and maximum load capability are a function of the MOSFET on-resistance, inductor value, and battery voltage. The reward for this uncertainty is robust, lossless overcurrent sensing. When combined with the undervoltage protection circuit, this current-limit method is effective in almost every circumstance.

There is also a negative current limit that prevents excessive reverse inductor currents when V_{OUT} is sinking current. The negative current-limit threshold is set to approximately 120% of the positive current limit, and therefore tracks the positive current limit when ILIM is adjusted.

The current-limit threshold is adjusted with internal 5μA current source and an external resistor at ILIM. The current-limit threshold adjustment range is from 50mV to 200mV, corresponding to resistor values of 100kΩ to 400kΩ. In the adjustable mode, the current-limit threshold voltage is precisely 1/10 the voltage seen at ILIM. The threshold defaults to 100mV when ILIM is connected to VCC. The logic threshold for switchover to the 100mV default value is approximately $V_{CC} - 1V$.

The adjustable current limit accommodates MOSFETs with a wide range of on-resistance characteristics (see *Design Procedure*).

Carefully observe the PC board layout guidelines to ensure that noise and DC errors don't corrupt the current-sense signals seen by LX and PGND. Mount or

Ultra-High Efficiency, Dual Step-Down Controller for Notebook Computers

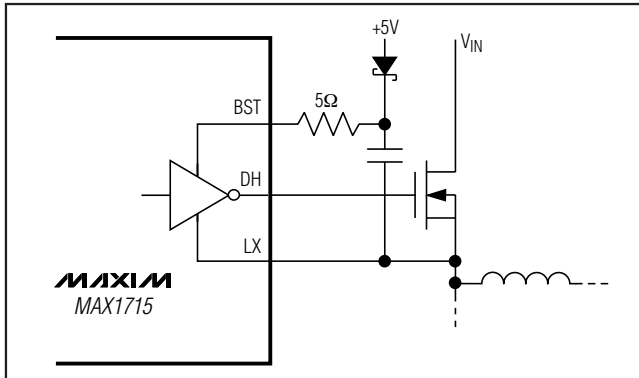

Figure 6. Reducing the Switching-Node Rise Time

place the IC close to the low-side MOSFET with short, direct traces, making a Kelvin sense connection to the source and drain terminals.

MOSFET Gate Drivers (DH, DL)

The DH and DL drivers are optimized for driving moderate-size, high-side and larger, low-side power MOSFETs. This is consistent with the low duty factor seen in the notebook CPU environment, where a large $V_{BATT} - V_{OUT}$ differential exists. An adaptive dead-time circuit monitors the DL output and prevents the high-side FET from turning on until DL is fully off. There must be a low-resistance, low-inductance path from the DL driver to the MOSFET gate for the adaptive dead-time circuit to work properly. Otherwise, the sense circuitry in the MAX1715 will interpret the MOSFET gate as “off” while there is actually still charge left on the gate. Use very short, wide traces measuring 10 to 20 squares (50 to 100 mils wide if the MOSFET is 1 inch from the MAX1715).

The dead time at the other edge (DH turning off) is determined by a fixed 35ns (typ) internal delay.

The internal pull-down transistor that drives DL low is robust, with a 0.5Ω typical on-resistance. This helps prevent DL from being pulled up during the fast rise-time of the inductor node, due to capacitive coupling from the drain to the gate of the low-side synchronous-rectifier MOSFET. However, for high-current applications, you might still encounter some combinations of high- and low-side FETs that will cause excessive gate-drain coupling, which can lead to efficiency-killing, EMI-producing shoot-through currents. This is often remedied by adding a resistor in series with BST, which increases the turn-on time of the high-side FET without degrading the turn-off time (Figure 6).

POR, UVLO, and Soft-Start

Power-on reset (POR) occurs when V_{CC} rises above approximately 2V, resetting the fault latch and soft-start counter and preparing the PWM for operation. V_{CC} undervoltage lockout (UVLO) circuitry inhibits switching and forces the DL gate driver high (to enforce output overvoltage protection) until V_{CC} rises above 4.2V, whereupon an internal digital soft-start timer begins to ramp up the maximum allowed current limit. The ramp occurs in five steps: 20%, 40%, 60%, 80%, and 100%; 100% current is available after 1.7ms \pm 50%.

A continuously adjustable analog soft-start function can be realized by adding a capacitor in parallel with the ILIM external resistor. This soft-start method requires a minimum interval between power-down and power-up to discharge the capacitor.

Power-Good Output (PGOOD)

The output voltage is continuously monitored for undervoltage by the PGOOD comparator. In shutdown, soft-start, and standby modes, PGOOD is actively held low. After digital soft-start has terminated, PGOOD is released if both the outputs are within 5.5% of the error comparator threshold. The PGOOD output is a true open-drain type with no parasitic ESD diodes. Note that the PGOOD undervoltage detector is completely independent of the output UVP fault detector.

Output Overvoltage Protection (OVP)

The overvoltage protection circuit is designed to protect against a shorted high-side MOSFET by drawing high current and blowing the battery fuse. The output voltage is continuously monitored for overvoltage. If the output is more than 10.5% above the trip level of the error amplifier, OVP is triggered and the circuit shuts down. The DL low-side gate-driver output is then latched high until \overline{SHDN} is toggled or V_{CC} power is cycled below 1V. This action turns on the synchronous-rectifier MOSFET with 100% duty and, in turn, rapidly discharges the output filter capacitor and forces the output to ground. If the condition that caused the overvoltage (such as a shorted high-side MOSFET) persists, the battery fuse will blow. DL is also kept high continuously when V_{CC} UVLO is active, as well as in shutdown mode (Table 3).

Note that DL latching high causes the output voltage to go slightly negative, due to energy stored in the output LC at the instant OVP activates. If the load can't tolerate being forced to a negative voltage, it may be desirable to place a power Schottky diode across the output to act as a reverse-polarity clamp (Figure 1).

Ultra-High Efficiency, Dual Step-Down Controller for Notebook Computers

Overvoltage protection can be defeated through the $\overline{\text{SKIP}}$ test mode (Table 3).

Output Undervoltage Protection (UVP)

The output undervoltage protection function is similar to foldback current limiting, but employs a timer rather than a variable current limit. If the MAX1715 output voltage is under 70% of the nominal value 20ms after coming out of shutdown, the PWM is latched off and won't restart until V_{CC} power is cycled or $\overline{\text{SHDN}}$ is toggled.

No-Fault Test Mode

The over/undervoltage protection features can complicate the process of debugging prototype breadboards since there are (at most) a few milliseconds in which to determine what went wrong. Therefore, a test mode is provided to totally disable the OVP, UVP, and thermal shutdown features, and clear the fault latch if it has been set. The PWM operates as if $\overline{\text{SKIP}}$ were grounded (PFM/PWM mode).

The no-fault test mode is entered by sinking 1.5mA from $\overline{\text{SKIP}}$ through an external negative voltage source in series with a resistor (Figure 7). $\overline{\text{SKIP}}$ is clamped to AGND with a silicon diode, so choose the resistor value equal to $(V_{\text{FORCE}} - 0.65V) / 1.5\text{mA}$.

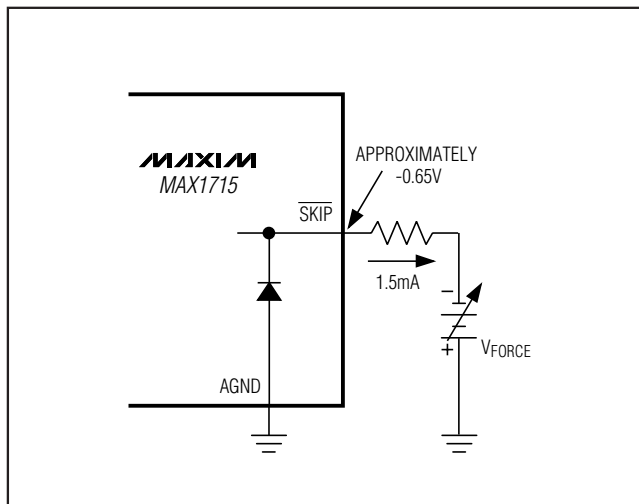

Figure 7. Disabling Over/Undervoltage Protection (Test Mode)

Design Procedure

Firmly establish the input voltage range and maximum load current before choosing a switching frequency and inductor operating point (ripple-current ratio). The primary design trade-off lies in choosing a good switching frequency and inductor operating point, and the following four factors dictate the rest of the design:

- 1) **Input voltage range.** The maximum value ($V_{\text{IN}(\text{MAX})}$) must accommodate the worst-case high AC adapter voltage. The minimum value ($V_{\text{IN}(\text{MIN})}$) must account for the lowest battery voltage after drops due to connectors, fuses, and battery selector switches. If there is a choice at all, lower input voltages result in better efficiency.
- 2) **Maximum load current.** There are two values to consider. The *peak load current* ($I_{\text{LOAD}(\text{MAX})}$) determines the instantaneous component stresses and filtering requirements, and thus drives output capacitor selection, inductor saturation rating, and the design of the current-limit circuit. The *continuous load current* (I_{LOAD}) determines the thermal stresses and thus drives the selection of input capacitors, MOSFETs, and other critical heat-contributing components. Modern notebook CPUs generally exhibit $I_{\text{LOAD}} = I_{\text{LOAD}(\text{MAX})} \cdot 80\%$.
- 3) **Switching frequency.** This choice determines the basic trade-off between size and efficiency. The optimal frequency is largely a function of maximum input voltage, due to MOSFET switching losses that are proportional to frequency and V_{IN}^2 . The optimum frequency is also a moving target, due to rapid improvements in MOSFET technology that are making higher frequencies more practical (Table 4).
- 4) **Inductor operating point.** This choice provides trade-offs between size vs. efficiency. Low inductor values cause large ripple currents, resulting in the smallest size, but poor efficiency and high output noise. The minimum practical inductor value is one that causes the circuit to operate at the edge of critical conduction (where the inductor current just touches zero with every cycle at maximum load). Inductor values lower than this grant no further size-reduction benefit.

The MAX1715's pulse-skipping algorithm initiates skip mode at the critical conduction point. So, the inductor operating point also determines the load-current value at which PFM/PWM switchover occurs. The optimum point is usually found between 20% and 50% ripple current.

Ultra-High Efficiency, Dual Step-Down Controller for Notebook Computers

The inductor ripple current also impacts transient-response performance, especially at low $V_{IN} - V_{OUT}$ differentials. Low inductor values allow the inductor current to slew faster, replenishing charge removed from the output filter capacitors by a sudden load step. The amount of output sag is also a function of the maximum duty factor, which can be calculated from the on-time and minimum off-time:

$$V_{SAG} = \frac{(\Delta I_{LOAD(MAX)})^2 \times L}{2 \times C_F \times DUTY (V_{IN(MIN)} - V_{OUT})}$$

where

$$DUTY = \frac{K (V_{OUT} + 0.075V) V_{IN}}{K (V_{OUT} + 0.075V) V_{OUT} + \text{min off-time}}$$

where minimum off-time = 400ns typ (see Table 5).

Inductor Selection

The switching frequency (on-time) and operating point (% ripple or LIR) determine the inductor value as follows:

$$L = \frac{V_{OUT} (V_{IN} - V_{OUT})}{V_{IN} \times f \times LIR \times I_{LOAD(MAX)}}$$

Example: $I_{LOAD(MAX)} = 8A$, $V_{IN} = 7V$, $V_{OUT} = 1.6V$, $f = 300kHz$, 35% ripple current or LIR = 0.35:

$$L = \frac{1.6V (7 - 1 \times 6)}{7 \times 300kHz \times 0.33 \times 8A} = 1.6\mu H$$

Find a low-loss inductor having the lowest possible DC resistance that fits in the allotted dimensions. Ferrite cores are often the best choice; although powdered iron is inexpensive and can work well at 200kHz. The core must be large enough not to saturate at the peak inductor current (I_{PEAK}):

$$I_{PEAK} = I_{LOAD(MAX)} + [(LIR / 2) \times I_{LOAD(MAX)}]$$

Determining the Current Limit

The minimum current-limit threshold must be great enough to support the maximum load current when the current limit is at the minimum tolerance value. The valley of the inductor current occurs at $I_{LOAD(MAX)}$ minus half of the ripple current; therefore:

$$I_{LIMIT(LOW)} > I_{LOAD(MAX)} - (LIR / 2) I_{LOAD(MAX)}$$

where $I_{LIMIT(LOW)}$ = minimum current-limit threshold voltage divided by the $R_{DS(ON)}$ of Q2. For the MAX1715, the minimum current-limit threshold (100mV default setting) is 90mV. Use the worst-case maximum value for $R_{DS(ON)}$ from the MOSFET Q2 data sheet, and add some margin for the rise in $R_{DS(ON)}$ with tempera-

ture. A good general rule is to allow 0.5% additional resistance for each °C of temperature rise.

Examining the 8A circuit example with a maximum $R_{DS(ON)} = 12m\Omega$ at high temperature reveals the following:

$$I_{LIMIT(LOW)} = 90mV / 12m\Omega = 7.5A$$

7.5A is greater than the valley current of 6.6A, so the circuit can easily deliver the full-rated 8A using the default 100mV nominal I_{LIM} threshold.

Output Capacitor Selection

The output filter capacitor must have low enough effective series resistance (ESR) to meet output ripple and load-transient requirements, yet have high enough ESR to satisfy stability requirements. Also, the capacitance value must be high enough to absorb the inductor energy going from a full-load to no-load condition without tripping the overvoltage protection circuit.

In CPU V_{CORE} converters and other applications where the output is subject to violent load transients, the output capacitor's size depends on how much ESR is needed to prevent the output from dipping too low under a load transient. Ignoring the sag due to finite capacitance:

$$R_{ESR} \leq \frac{V_{DIP}}{I_{LOAD(MAX)}}$$

In non-CPU applications, the output capacitor's size depends on how much ESR is needed to maintain an acceptable level of output voltage ripple:

$$R_{ESR} \leq \frac{V_{p-p}}{LIR \times I_{LOAD(MAX)}}$$

The actual microfarad capacitance value required relates to the physical size needed to achieve low ESR, as well as to the chemistry of the capacitor technology. Thus, the capacitor is usually selected by ESR and voltage rating rather than by capacitance value (this is true of tantalums, OS-CONs, and other electrolytics).

When using low-capacity filter capacitors such as ceramic or polymer types, capacitor size is usually determined by the capacity needed to prevent VSAG and VSOAR from causing problems during load transients. Also, the capacitance must be great enough to prevent the inductor's stored energy from launching the output above the overvoltage protection threshold. Generally, once enough capacitance is added to meet the overshoot requirement, undershoot at the rising load edge is no longer a problem (see the VSAG equation in the *Design Procedure*).

Ultra-High Efficiency, Dual Step-Down Controller for Notebook Computers

The amount of overshoot due to stored inductor energy can be calculated as:

$$\Delta V \approx \frac{L I_{PEAK}^2}{2 C V_{OUT}}$$

where I_{PEAK} is the peak inductor current.

Output Capacitor Stability Considerations

Stability is determined by the value of the ESR zero relative to the switching frequency. The point of instability is given by the following equation:

$$f_{ESR} = \frac{f}{\pi}$$

where:

$$f_{ESR} = \frac{1}{2 \times \pi \times R_{ESR} \times C_F}$$

For a typical 300kHz application, the ESR zero frequency must be well below 95kHz, preferably below 50kHz. Tantalum and OS-CON capacitors in widespread use at the time of publication have typical ESR zero frequencies of 15kHz. In the design example used for inductor selection, the ESR needed to support 50mVp-p ripple is $50\text{mV}/3.5\text{A} = 14.2\text{m}\Omega$. Three 470 $\mu\text{F}/4\text{V}$ Kemet T510 low-ESR tantalum capacitors in parallel provide 15m Ω max ESR. Their typical combined ESR results in a zero at 14.1kHz, well within the bounds of stability.

Don't put high-value ceramic capacitors directly across the fast feedback inputs (FB_ to AGND) without taking precautions to ensure stability. Large ceramic capacitors can have a high-ESR zero frequency and cause erratic, unstable operation. However, it's easy to add enough series resistance by placing the capacitors a couple of inches downstream from the junction of the inductor and FB_ pin (see the *All-Ceramic-Capacitor Application* section).

Unstable operation manifests itself in two related but distinctly different ways: double-pulsing and fast-feedback loop instability.

Double-pulsing occurs due to noise on the output or because the ESR is so low that there isn't enough voltage ramp in the output voltage signal. This "fools" the error comparator into triggering a new cycle immediately after the 400ns minimum off-time period has expired. Double-pulsing is more annoying than harmful, resulting in nothing worse than increased output ripple. However, it can indicate the possible presence of loop instability, which is caused by insufficient ESR.

Loop instability can result in oscillations at the output after line or load perturbations that can trip the overvoltage protection latch or cause the output voltage to fall below the tolerance limit.

The easiest method for checking stability is to apply a very fast zero-to-max load transient (refer to the MAX1715 EV kit manual) and carefully observe the output voltage ripple envelope for overshoot and ringing. It can help to simultaneously monitor the inductor current with an AC current probe. Don't allow more than one cycle of ringing after the initial step-response under- or overshoot.

Input Capacitor Selection

The input capacitor must meet the ripple current requirement (I_{RMS}) imposed by the switching currents. Nontantalum chemistries (ceramic, aluminum, or OS-CON) are preferred due to their resistance to power up surge currents.

$$I_{RMS} = I_{LOAD} \left(\frac{\sqrt{V_{OUT}(V_{IN} - V_{OUT})}}{V_{IN}} \right)$$

Power MOSFET Selection

Most of the following MOSFET guidelines focus on the challenge of obtaining high load-current capability (>5A) when using high-voltage (>20V) AC adapters. Low-current applications usually require less attention.

For maximum efficiency, choose a high-side MOSFET (Q1) that has conduction losses equal to the switching losses at the optimum battery voltage (15V). Check to ensure that the conduction losses at the **minimum** input voltage don't exceed the package thermal limits or violate the overall thermal budget. Check to ensure that conduction losses plus switching losses at the **maximum** input voltage don't exceed the package ratings or violate the overall thermal budget.

Choose a low-side MOSFET (Q2) that has the lowest possible $R_{DS(ON)}$, comes in a moderate to small package (i.e., SO-8), and is reasonably priced. Ensure that the MAX1715 DL gate driver can drive Q2; in other words, check that the gate isn't pulled up by the high-side switch turning on due to parasitic drain-to-gate capacitance, causing cross-conduction problems. Switching losses aren't an issue for the low-side MOSFET since it's a zero-voltage switched device when used in the buck topology.

MOSFET Power Dissipation

Worst-case conduction losses occur at the duty factor extremes. For the high-side MOSFET, the worst-case-

Ultra-High Efficiency, Dual Step-Down Controller for Notebook Computers

power dissipation (PD) due to resistance occurs at minimum battery voltage:

$$PD(Q1 \text{ resistance}) = \left(\frac{V_{OUT}}{V_{IN(MIN)}} \right) I_{LOAD}^2 \times R_{DS(ON)}$$

Generally, a small high-side MOSFET is desired in order to reduce switching losses at high input voltages. However, the $R_{DS(ON)}$ required to stay within package power-dissipation limits often limits how small the MOSFET can be. Again, the optimum occurs when the switching (AC) losses equal the conduction ($R_{DS(ON)}$) losses. High-side switching losses don't usually become an issue until the input is greater than approximately 15V.

Switching losses in the high-side MOSFET can become an insidious heat problem when maximum AC adapter voltages are applied, due to the squared term in the CV^2F switching loss equation. If the high-side MOSFET you've chosen for adequate $R_{DS(ON)}$ at low battery voltages becomes extraordinarily hot when subjected to $V_{IN(MAX)}$, reconsider your choice of MOSFET.

Calculating the power dissipation in Q1 due to switching losses is difficult since it must allow for difficult quantifying factors that influence the turn-on and turn-off times. These factors include the internal gate resistance, gate charge, threshold voltage, source inductance, and PC board layout characteristics. The following switching loss calculation provides only a very rough estimate and is no substitute for bread-board evaluation, preferably including a verification using a thermocouple mounted on Q1:

$$PD(Q1 \text{ switching}) = \frac{C_{RSS} \times V_{IN(MAX)}^2 \times f \times I_{LOAD}}{I_{GATE}}$$

where C_{RSS} is the reverse transfer capacitance of Q1 and I_{GATE} is the peak gate-drive source/sink current (1A typ).

For the low-side MOSFET, Q2, the worst-case power dissipation always occurs at maximum battery voltage:

$$PD(Q2) = \left(\frac{1 - V_{OUT}}{V_{IN(MAX)}} \right) I_{LOAD}^2 \times R_{DS(ON)}$$

The absolute worst case for MOSFET power dissipation occurs under heavy overloads that are greater than $I_{LOAD(MAX)}$ but are not quite high enough to exceed the current limit and cause the fault latch to trip. To protect against this possibility, you must "overdesign" the circuit to tolerate:

$$I_{LOAD} = I_{LIMIT(HIGH)} + (LIR / 2) \times I_{LOAD(MAX)}$$

where $I_{LIMIT(HIGH)}$ is the maximum valley current allowed by the current-limit circuit, including threshold tolerance and on-resistance variation. This means that the MOSFETs must be very well heatsinked. If short-circuit protection without overload protection is enough, a normal I_{LOAD} value can be used for calculating component stresses.

Choose a Schottky diode (D1) having a forward voltage low enough to prevent the Q2 MOSFET body diode from turning on during the dead time. As a general rule, a diode having a DC current rating equal to 1/3 of the load current is sufficient. This diode is optional and can be removed if efficiency isn't critical.

Application Issues

Dropout Performance

The output voltage adjust range for continuous-conduction operation is restricted by the nonadjustable 500ns (max) minimum off-time one-shot. For best dropout performance, use the slowest (200kHz) on-time setting. When working with low input voltages, the duty-factor limit must be calculated using worst-case values for on- and off-times. Manufacturing tolerances and internal propagation delays introduce an error to the TON K-factor. This error is greater at higher frequencies (Table 5). Also, keep in mind that transient response performance of buck regulators operated close to dropout is poor, and bulk output capacitance must often be added (see the VSAG equation in the *Design Procedure*).

Dropout design example: $V_{IN} = 3V$ min, $V_{OUT} = 2V$, $f = 300kHz$. The required duty is $(V_{OUT} + V_{SW}) / (V_{IN} - V_{SW}) = (2V + 0.1V) / (3.0V - 0.1V) = 72.4\%$. The worst-case on-time is $(V_{OUT} + 0.075) / V_{IN} \times K = 2.075V / 3V \times 3.35\mu s \times 90\% = 2.08\mu s$. The IC duty-factor limitation is:

$$DUTY = \frac{t_{ON(MIN)}}{t_{ON(MIN)} + t_{OFF(MAX)}} = \frac{2.08\mu s}{2.08\mu s + 500ns} = 80.6\%$$

which meets the required duty.

Remember to include inductor resistance and MOSFET on-state voltage drops (V_{SW}) when doing worst-case dropout duty-factor calculations.

All-Ceramic-Capacitor Application

Ceramic capacitors have advantages and disadvantages. They have ultra-low ESR and are noncombustible, relatively small, and nonpolarized. They are also expensive and brittle, and their ultra-low ESR characteristic can result in excessively high ESR zero frequencies (affecting stability). In addition, their relatively low capacitance value can cause output overshoot

Ultra-High Efficiency, Dual Step-Down Controller for Notebook Computers

MAX1715

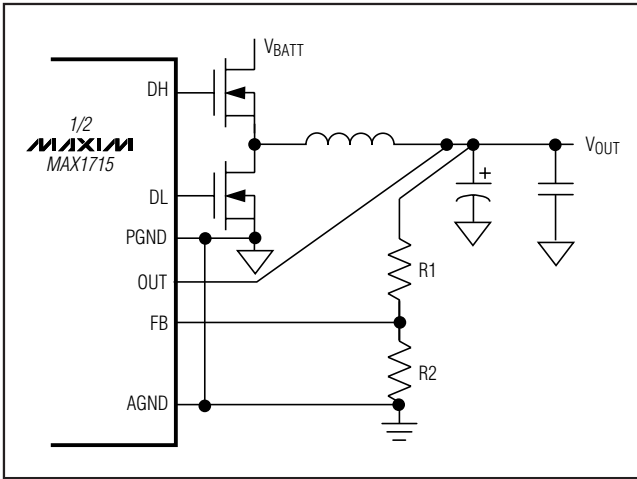

Figure 8. Setting V_{OUT} with a Resistor-Divider

when going abruptly from full-load to no-load conditions, unless there are some bulk tantalum or electrolytic capacitors in parallel to absorb the stored energy in the inductor. In some cases, there may be no room for electrolytics, creating a need for a DC-DC design that uses nothing but ceramics.

The all-ceramic-capacitor application of Figure 8 replaces the standard tantalum output capacitors with ceramics. This design relies on having a minimum of $5\text{m}\Omega$ parasitic PC board trace resistance in series with the capacitor to reduce the ESR zero frequency. This small amount of resistance is easily obtained by locating the MAX1714A circuit 2 or 3 inches away from the CPU, and placing all the ceramic capacitors close to the CPU. Resistance values higher than $5\text{m}\Omega$ just improve the stability (which can be observed by examining the load-transient response characteristic as shown in the *Typical Operating Characteristics*). Avoid adding excess PC board trace resistance, as there's an efficiency penalty; $5\text{m}\Omega$ is sufficient for a 7A circuit:

$$R_{\text{ESR}} \geq \frac{1}{2fC_{\text{OUT}}}$$

Output overshoot (ΔV) determines the minimum output capacitance requirement. In this example, the switching frequency has been increased to 600kHz and the inductor value has been reduced to $0.5\mu\text{H}$ (compared to 300kHz and $2\mu\text{H}$ for the standard 8A circuit) to minimize the energy transferred from inductor to capacitor during load-step recovery. The overshoot must be calculated to avoid tripping the OVP latch. The efficiency

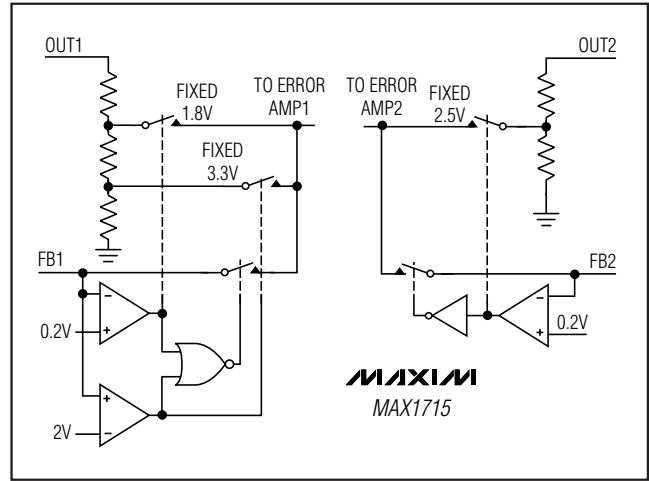

Figure 9. Feedback Mux

penalty for operating at 540kHz is about 2% to 3%, depending on the input voltage.

An optional 1Ω resistor is placed in series with OUT. This resistor attenuates high-frequency noise in some bands, which causes double pulsing.

Fixed Output Voltages

The MAX1715's Dual Mode™ operation allows the selection of common voltages without requiring external components (Figure 9). Connect FB to AGND for a fixed +2.5V output or to V_{CC} for a +3.3V output, or connect FB directly to OUT for a fixed +1.0V output.

Setting V_{OUT} with a Resistor-Divider

The output voltage can be adjusted with a resistor-divider if desired (Figure 8). The equation for adjusting the output voltage is:

$$V_{\text{OUT}} = V_{\text{FB}} \left(1 + \frac{R_1}{R_2} \right)$$

where V_{FB} is 1.0V and R_2 is about $10\text{k}\Omega$.

Two-Stage (5V-Powered) Notebook CPU Buck Regulator

The most efficient and overall cost-effective solution for stepping down a high-voltage battery to a very low output voltage is to use a single-stage buck regulator that's powered directly from the battery. However, there may be situations where the battery bus can't be routed near the CPU, or where space constraints dictate the smallest possible local DC-DC converter. In such cases, the 5V-powered circuit of Figure 10 may be appropriate. The reduced input voltage allows a higher

Dual Mode is a trademark of Maxim Integrated Products.

Ultra-High Efficiency, Dual Step-Down Controller for Notebook Computers

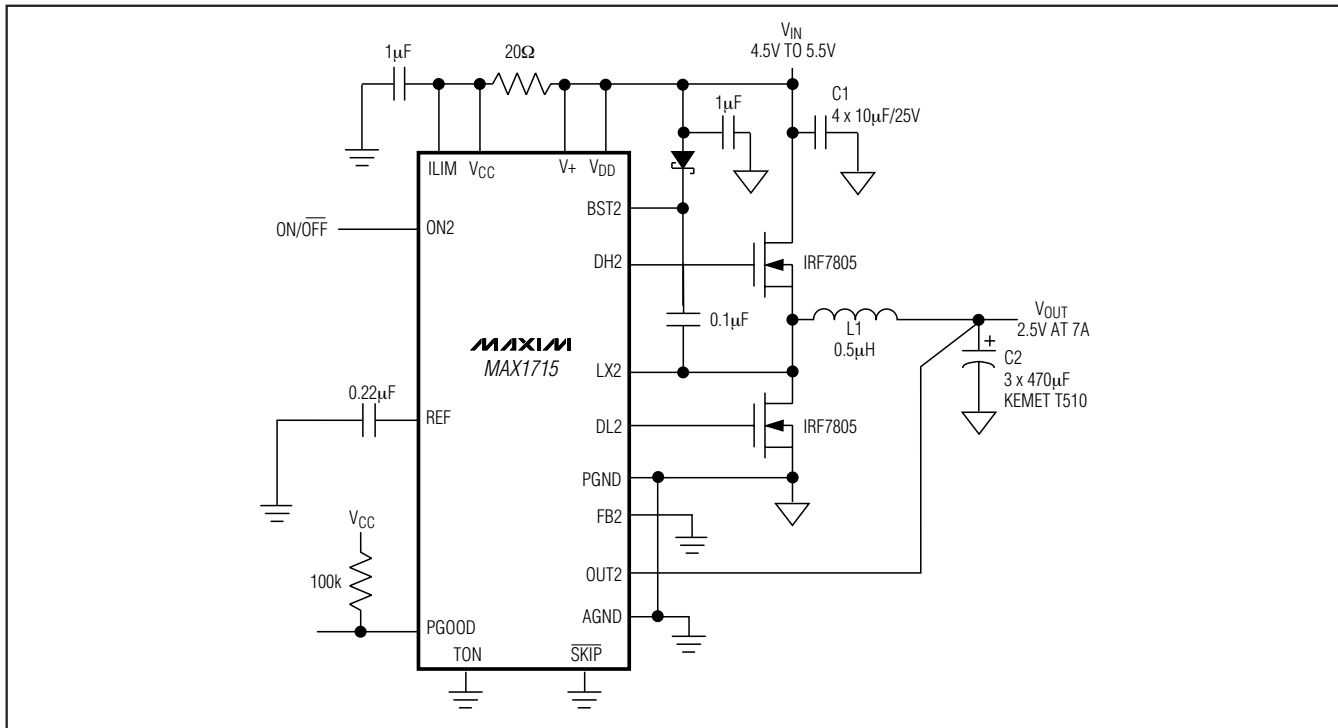

Figure 10. 5V-Powered, 8A CPU Buck Regulator

switching frequency and a much smaller inductor value.

PC Board Layout Guidelines

Careful PC board layout is critical to achieving low switching losses and clean, stable operation. This is especially true for dual converters, where one channel can affect the other. The switching power stages require particular attention (Figure 11). Refer to the MAX1715 EV kit data sheet for a specific layout example.

If possible, mount all of the power components on the top side of the board with their ground terminals flush against one another. Follow these guidelines for good PC board layout:

- Isolate the power components on the top side from the sensitive analog components on the bottom side with a ground shield. Use a separate PGND plane under the OUT1 and OUT2 sides (called PGND1 and PGND2). Avoid the introduction of AC currents into the PGND1 and PGND2 ground planes. Run the power plane ground currents on the top side only, if possible.
- Use a star ground connection on the power plane to minimize the crosstalk between OUT1 and OUT2.
- Keep the high-current paths short, especially at the ground terminals. This practice is essential for stable, jitter-free operation.
- Tie AGND and PGND together close to the IC. Do not connect them together anywhere else. Carefully follow the grounding instructions under Step 4 of the *Layout Procedure*.
- Keep the power traces and load connections short. This practice is essential for high efficiency. Using thick copper PC boards (2oz vs. 1oz) can enhance full-load efficiency by 1% or more. Correctly routing PC board traces is a difficult task that must be approached in terms of fractions of centimeters, where a single milliohm of excess trace resistance causes a measurable efficiency penalty.
- LX₂ and PGND connections to the synchronous rectifiers for current limiting must be made using Kelvin sense connections to guarantee the current-limit accuracy. With SO-8 MOSFETs, this is best done by routing power to the MOSFETs from outside using the top copper layer, while tying in PGND and LX₂ inside (underneath) the SO-8 package.
- When trade-offs in trace lengths must be made, it's preferable to allow the inductor charging path to be

Ultra-High Efficiency, Dual Step-Down Controller for Notebook Computers

made longer than the discharge path. For example, it's better to allow some extra distance between the input capacitors and the high-side MOSFET than to allow distance between the inductor and the low-side MOSFET or between the inductor and the output filter capacitor.

- Ensure that the OUT connection to C_{OUT} is short and direct. However, in some cases it may be desirable to deliberately introduce some trace length between the OUT inductor node and the output filter capacitor (see the *All-Ceramic-Capacitor Application* section).
- Route high-speed switching nodes (BST_, LX_, DH_, and DL_) away from sensitive analog areas (REF, ILIM, FB). Use PGND1 and PGND2 as EMI shields to keep radiated switching noise away from the IC, feedback dividers, and analog bypass capacitors.
- Make all pin-strap control input connections (\overline{SKIP} , ILIM, etc.) to AGND or V_{CC} rather than PGND_or V_{DD} .

Layout Procedure

- 1) Place the power components first, with ground terminals adjacent (Q2 source, C_{IN-} , C_{OUT-} , D1 anode). If possible, make all these connections on the top layer with wide, copper-filled areas.
- 2) Mount the controller IC adjacent to the synchronous rectifiers MOSFETs, preferably on the back side in order to keep LX_, PGND_, and the DL_ gate-drive line short and wide. The DL_ gate trace must be short and wide, measuring 10 to 20 squares (50mils to 100mils wide if the MOSFET is 1 inch from the controller IC).
- 3) Group the gate-drive components (BST_ diode and capacitor, V_{DD} bypass capacitor) together near the controller IC.

- 4) Make the DC-DC controller ground connections as follows: near the IC, create a small analog ground plane. Connect this plane to AGND and use this plane for the ground connection for the REF and V_{CC} bypass capacitors, FB dividers, and ILIM resistors (if any). Create another small ground island for PGND, and use it for the V_{DD} bypass capacitor, placed very close to the IC. Connect the AGND and the PGND pins together under the IC (this is the only connection between AGND and PGND).
- 5) On the board's top side (power planes), make a star ground to minimize crosstalk between the two sides. The top-side star ground is a star connection of the input capacitors, side 1 low-side MOSFET, and side 2 low-side MOSFET. Keep the resistance low between the star ground and the source of the low-side MOSFETs for accurate current limit. Connect the top-side star ground (used for MOSFET, input, and output capacitors) to the small PGND island with a short, wide connection (preferably just a via).

If multiple layers are available (highly recommended), create PGND1 and PGND2 islands on the layer just below the top-side layer (refer to the MAX1715 EV kit for an example) to act as an EMI shield. Connect each of these individually to the star ground via, which connects the top side to the PGND plane. Add one more solid ground plane under the IC to act as an additional shield, and also connect that to the star ground via.

- 6) Connect the output power planes (V_{CORE} and system ground planes) directly to the output filter capacitor positive and negative terminals with multiple vias.

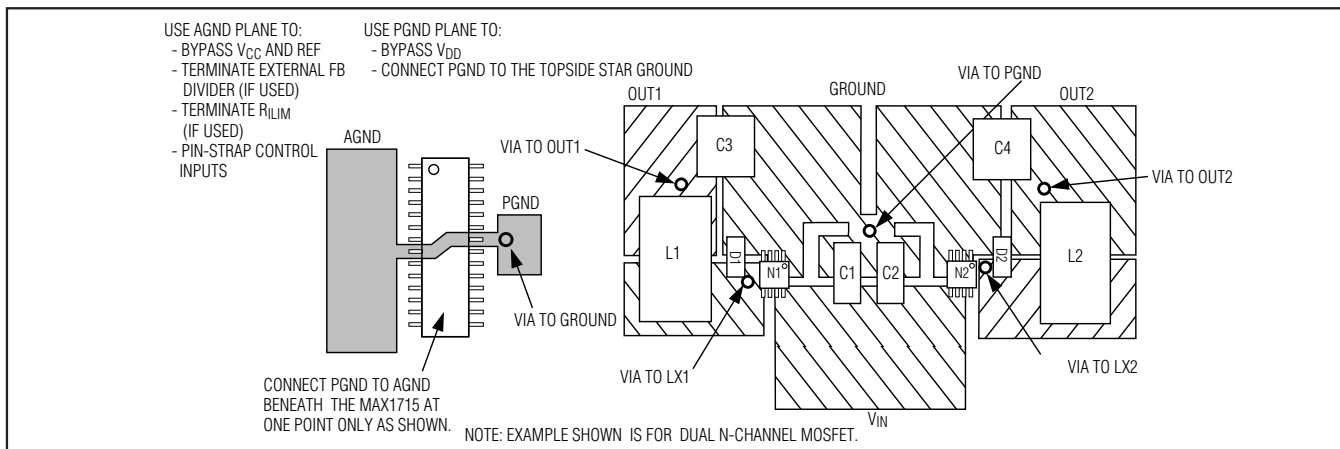
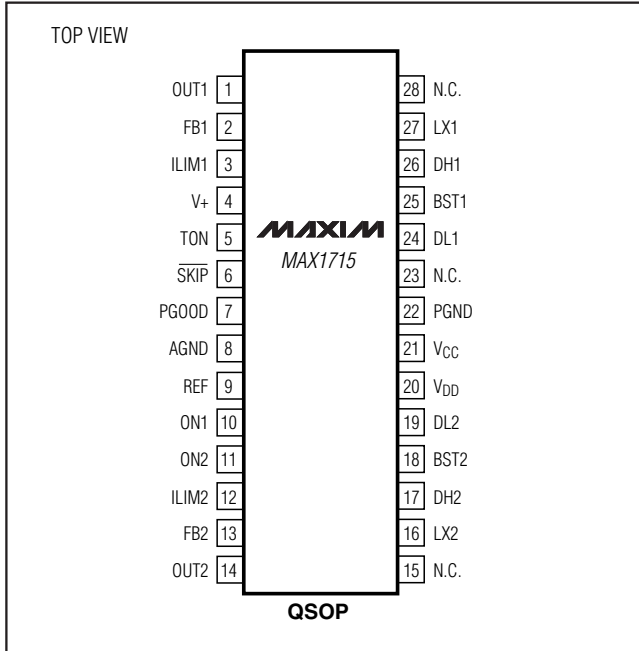

Figure 11. PC Board Layout Example

Ultra-High Efficiency, Dual Step-Down Controller for Notebook Computers

Pin Configuration



Ultra-High Efficiency, Dual Step-Down Controller for Notebook Computers

Package Information

(The package drawing(s) in this data sheet may not reflect the most current specifications. For the latest package outline information go to www.maxim-ic.com/packages.)

MAX1715

QSOP EPSS

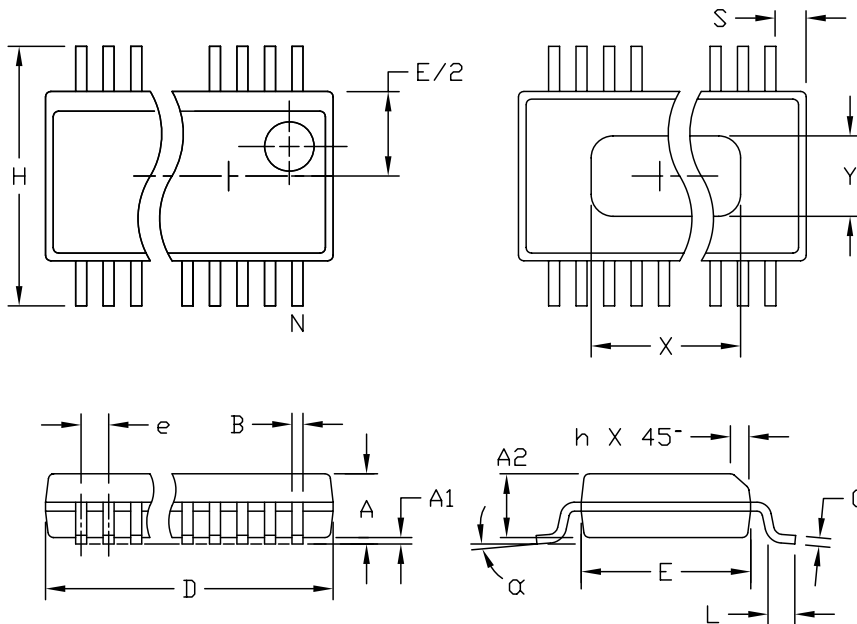

DIM	INCHES		MILLIMETERS	
	MIN	MAX	MIN	MAX
A	.061	.068	1.55	1.73
A1	.004	.0098	0.102	0.249
A2	.055	.061	1.40	1.55
B	.008	.012	0.20	0.31
C	.0075	.0098	0.191	0.249
D	SEE VARIATIONS			
E	.150	.157	3.81	3.99
e	.025 BSC		0.635 BSC	
H	.230	.244	5.84	6.20
h	.010	.016	0.25	0.41
L	.016	.035	0.41	0.89
N	SEE VARIATIONS			
X	SEE VARIATIONS			
Y	.071	.087	1.803	2.209
α	0°	8°	0°	8°

VARIATIONS:

DIM	INCHES		MILLIMETERS		N
	MIN.	MAX.	MIN.	MAX.	
D	.189	.196	4.80	4.98	16 AA
S	.0020	.0070	0.05	0.18	
X	.107	.123	2.72	3.12	
D	.337	.344	8.56	8.74	20 AB
S	.0500	.0550	1.270	1.397	
D	.337	.344	8.56	8.74	24 AC
S	.0250	.0300	0.635	0.762	
D	.386	.393	9.80	9.98	28 AD
S	.0250	.0300	0.635	0.762	
X	.271	.287	6.88	7.29	

NOTES:

1. D & E DO NOT INCLUDE MOLD FLASH OR PROTRUSIONS.
2. MOLD FLASH OR PROTRUSIONS NOT TO EXCEED .006" PER SIDE.
3. HEAT SLUG DIMENSIONS X AND Y APPLY ONLY TO 16 AND 28 LEAD POWER-QSOP PACKAGES.
4. CONTROLLING DIMENSIONS: INCHES.
5. MEETS JEDEC MQ137.



MAXIM
 PROPRIETARY INFORMATION
 TITLE:
 PACKAGE OUTLINE, QSOP, .150", .025" LEAD PITCH
 APPROVAL: _____ DOCUMENT CONTROL NO. 21-0055 REV C 1/1

Maxim cannot assume responsibility for use of any circuitry other than circuitry entirely embodied in a Maxim product. No circuit patent licenses are implied. Maxim reserves the right to change the circuitry and specifications without notice at any time.

25 **Maxim Integrated Products, 120 San Gabriel Drive, Sunnyvale, CA 94086 408-737-7600**

Looking for pricing, stock, or lifecycle information?

Click below to explore more details on WIN SOURCE:

-  [View MAX1715EEI+ on WIN SOURCE](#)
-  [Maxim Integrated Information](#)

Optimize Your Supply Chain with WIN SOURCE Solutions

-  Global Sourcing Solution
-  Obsolete Management
-  Cost Control Management
-  Shortage Management
-  Alternative Solution
-  Excess Inventory Management