



**THE DATASHEET OF
MAX1833ETT30-T**



Click [here](#) for production status of specific part numbers.

MAX1832–MAX1835

High-Efficiency Step-Up Converters with Reverse Battery Protection

General Description

The MAX1832–MAX1835 are high-efficiency step-up converters with complete reverse battery protection that protects the device and the load when the battery is reversed. They feature a built-in synchronous rectifier, which allows for over 90% efficiency and reduces size and cost by eliminating the need for an external Schottky diode.

These step-up converters operate from a +1.5V to +5.5V input voltage range and deliver up to 150mA of load current. The MAX1833EUT/MAX1835EUT (SOT devices) have a fixed 3.3V output voltage. The MAX1833ETT30 (TDFN device) has a fixed 3.0V output voltage. The MAX1832/MAX1834 have adjustable outputs from +2V to +5.5V. In shutdown, the MAX1832/MAX1833 connect the battery input to the voltage output, allowing the input battery to be used as a backup or real-time clock supply when the converter is off (see *Selector Guide*).

MAX183_EUT devices are available in a miniature 6-pin SOT23 package. The MAX1833ETT30 is available in a 3mm x 3mm thin DFN package. The MAX1832EVKIT is available to speed designs.

Applications

- Medical Diagnostic Equipment
- Pagers
- Hand-Held Instruments
- Remote Wireless Transmitters
- Digital Cameras
- Cordless Phones
- Battery Backup
- PC Cards
- Local 3.3V or 5V Supply

Pin Configurations

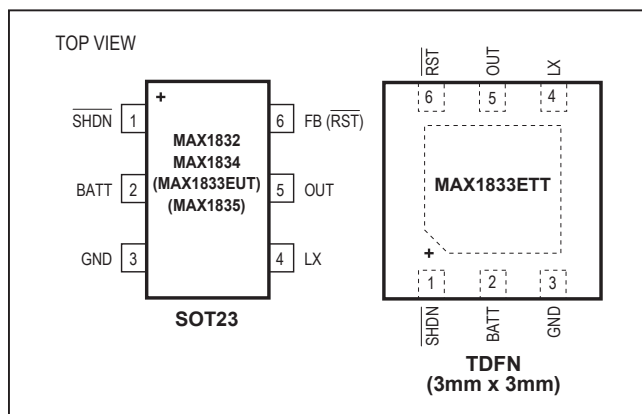

Features

- Reverse Battery Protection for DC-DC Converter and Load
- Up to 90% Efficiency
- No External Diode or FETs Needed
- Internal Synchronous Rectifier
- 4µA Quiescent Current
- <1µA Shutdown Supply Current
- +1.5V to +5.5V Input Voltage Range
- Accurate $\overline{\text{SHDN}}$ Threshold for Low-Battery Cutoff
- BATT Connected to OUT in Shutdown for Backup Power (MAX1832/MAX1833)
- $\overline{\text{RST}}$ Output (MAX1833/MAX1835)
- Fixed 3.3V/3.0V Output Voltage
- Adjustable Output Voltage (MAX1832/MAX1834)
- Up to 150mA Output Current
- Tiny 6-Pin SOT23 Package
- Tiny 6-Pin Thin QFN Package (MAX1833ETT30)

Ordering Information

PART	TEMP RANGE	PIN-PACKAGE	TOP MARK
MAX1832EUT+T	-40°C to +85°C	6 SOT23-6	AAOT
MAX1833EUT+T	-40°C to +85°C	6 SOT23-6	AAOU
MAX1833ETT30+T	-40°C to +85°C	6 TDFN-6 (T633-1)	ABX
MAX1834EUT+T	-40°C to +85°C	6 SOT23-6	AAOV
MAX1835EUT+T	-40°C to +85°C	6 SOT23-6	AAOW

Selector Guide

PART	OUTPUT VOLTAGE	OUTPUT VOLTAGE IN SHUTDOWN
MAX1832EUT+T	Adjustable	V_{BATT}
MAX1833EUT+T	Fixed 3.3V	V_{BATT}
MAX1833ETT30+T	Fixed 3.0V	V_{BATT}
MAX1834EUT+T	Adjustable	$V_{\text{BATT}} - 0.7\text{V}$
MAX1835EUT+T	Fixed 3.3V	$V_{\text{BATT}} - 0.7\text{V}$

Absolute Maximum Ratings

BATT, LX to GND-6V to +6V
 LX to OUT-6V to +1V
 SHDN to GND -6V to (V_{OUT} + 0.3V)
 OUT, FB, R_{ST} TO GND-0.3V to +6V
 LX Current 1A
 Continuous Power Dissipation (T_A = +70°C)
 6-Pin SOT23 (derate 9.1mW/°C above +70°C)727mW
 6-Pin 3mm x 3mm TDFN (derate 18.2mW/°C above +70°C) 1454.5mW

Operating Temperature Range -40°C to +85°C
 Junction Temperature +150°C
 Storage Temperature Range -65°C to +150°C
 Lead Temperature (soldering, 10s) +300°C

Stresses beyond those listed under "Absolute Maximum Ratings" may cause permanent damage to the device. These are stress ratings only, and functional operation of the device at these or any other conditions beyond those indicated in the operational sections of the specifications is not implied. Exposure to absolute maximum rating conditions for extended periods may affect device reliability.

Electrical Characteristics

(V_{SHDN} = +1.5V, V_{OUT} = +3.3V, V_{BATT} = +2V, GND = 0, T_A = -40°C to +85°C. Typical values are at T_A = +25°C, unless otherwise noted.) (Note 1)

PARAMETER	SYMBOL	CONDITIONS		MIN	TYP	MAX	UNITS
Output Range	V _{OUT}	MAX1832/MAX1834		2.0		5.5	V
Battery Input Range	V _{BATT}			1.5		5.5	V
Startup Battery Input Voltage	V _{SU}	R _{LOAD} = 2.6kΩ	T _A = +25°C		1.22	1.5	V
			T _A = -40°C to +85°C		1.24		
Output Voltage	V _{OUT}	MAX1833EUT/ MAX1835EUT	T _A = +25°C	3.225	3.290	3.355	V
			T _A = -40°C to +85°C	3.208		3.372	
		MAX1833ETT30	T _A = +25°C	2.94	3.0	3.06	
			T _A = -40°C to +85°C	2.925		3.075	
FB Trip Voltage	V _{FB}	MAX1832/ MAX1834	T _A = +25°C	1.208	1.228	1.248	V
			T _A = -40°C to +85°C	1.204		1.252	
FB Input Bias Current	I _{FB}	MAX1832/ MAX1834, V _{FB} = +1.3V	T _A = +25°C		3.5	20	nA
			T _A = -40°C to +85°C		4.0		
N-Channel On-Resistance	R _{NCH}	V _{OUT} = +3.3V I _{LX} = 100mA	T _A = +25°C		0.4	1.2	Ω
			T _A = -40°C to +85°C			1.5	
P-Channel On-Resistance	R _{PCH}	V _{OUT} = +3.3V I _{LX} = 100mA	T _A = +25°C		0.5	1.3	Ω
			T _A = -40°C to +85°C			1.6	
P-Channel Catch-Diode Voltage		I _{LX} = 100mA, PCH off, V _{OUT} = +3.5V, V _{FB} = +1.3V			0.73		V
N-Channel Switch Current Limit	I _{MAX}	V _{OUT} = +3.3V	T _A = +25°C	435	525	615	mA
			T _A = -40°C to +85°C	400		650	
Switch Maximum On-Time	t _{ON}			3.5	5	6.5	μs
Synchronous Rectifier Zero-Crossing Current		V _{OUT} = +3.3V	T _A = +25°C	2	17	34	mA
			T _A = -40°C to +85°C	0		39	
Quiescent Current into OUT (Note 2)		V _{OUT} = +3.5V, V _{FB} = +1.3V	T _A = +25°C		2.5	7.0	μA
			T _A = -40°C to +85°C			8.0	
Shutdown Current into OUT		V _{OUT} = +3.5V, V _{SHDN} = V _{FB} = 0V			0.05	1	μA

Electrical Characteristics (continued)

($V_{\text{SHDN}} = +1.5\text{V}$, $V_{\text{OUT}} = +3.3\text{V}$, $V_{\text{BATT}} = +2\text{V}$, $\text{GND} = 0$, $T_{\text{A}} = -40^{\circ}\text{C}$ to $+85^{\circ}\text{C}$. Typical values are at $T_{\text{A}} = +25^{\circ}\text{C}$, unless otherwise noted.) (Note 1)

PARAMETER	SYMBOL	CONDITIONS		MIN	TYP	MAX	UNITS
Reverse Battery Current into OUT		$V_{\text{OUT}} = 0$, $V_{\text{BATT}} = V_{\text{SHDN}} = V_{\text{LX}} = -3\text{V}$			0	10	μA
Quiescent Current into BATT		$V_{\text{OUT}} = +3.5\text{V}$, $V_{\text{FB}} = +1.3\text{V}$	$T_{\text{A}} = +25^{\circ}\text{C}$		1.8	5.0	μA
			$T_{\text{A}} = -40^{\circ}\text{C}$ to $+85^{\circ}\text{C}$			6.0	
Shutdown Current into BATT		$V_{\text{OUT}} = +3.5\text{V}$, $V_{\text{BATT}} = +2\text{V}$, $V_{\text{SHDN}} = 0$			0.001	1	μA
Reverse Battery Current into BATT		$V_{\text{OUT}} = 0$, $V_{\text{BATT}} = V_{\text{SHDN}} = V_{\text{LX}} = -3\text{V}$			0.002	10	μA
SHDN Logic Low		$V_{\text{BATT}} = +1.5\text{V}$ to $+5.5\text{V}$				0.3	V
SHDN Threshold		Rising edge	$T_{\text{A}} = +25^{\circ}\text{C}$	1.185	1.228	1.271	V
			$T_{\text{A}} = -40^{\circ}\text{C}$ to $+85^{\circ}\text{C}$	1.170		1.286	
SHDN Threshold Hysteresis					0.02		V
SHDN Input Bias Current		$V_{\text{OUT}} = +5.5\text{V}$, $V_{\text{SHDN}} = +5.5\text{V}$, $T_{\text{A}} = +25^{\circ}\text{C}$			13	100	nA
SHDN Reverse Battery Current		$V_{\text{OUT}} = 0$, $V_{\text{BATT}} = V_{\text{SHDN}} = V_{\text{LX}} = -3\text{V}$			52	150	μA
RST Threshold		MAX1833EUT/ MAX1835EUT, falling edge	$T_{\text{A}} = +25^{\circ}\text{C}$	2.830	2.980	3.110	V
			$T_{\text{A}} = -40^{\circ}\text{C}$ to $+85^{\circ}\text{C}$	2.800		3.140	
		MAX1833ETT30	$T_{\text{A}} = +25^{\circ}\text{C}$	2.580	2.717	2.836	
			$T_{\text{A}} = -40^{\circ}\text{C}$ to $+85^{\circ}\text{C}$	2.553		2.863	
RST Voltage Low		$I_{\text{RST}} = 1\text{mA}$, $V_{\text{OUT}} = +2.5\text{V}$				0.2	V
RST Leakage Current		$V_{\text{RST}} = +5.5\text{V}$	$T_{\text{A}} = +25^{\circ}\text{C}$		0.1	100	nA
			$T_{\text{A}} = -40^{\circ}\text{C}$ to $+85^{\circ}\text{C}$		1		
LX Leakage Current		$V_{\text{LX}} = +5.5\text{V}$	$T_{\text{A}} = +25^{\circ}\text{C}$		1	100	nA
			$T_{\text{A}} = -40^{\circ}\text{C}$ to $+85^{\circ}\text{C}$		100		
LX Reverse Battery Current		$V_{\text{OUT}} = 0$, $V_{\text{BATT}} = V_{\text{SHDN}} = V_{\text{LX}} = -3\text{V}$			0.001	10	μA
Maximum Load Current	I_{LOAD}	$V_{\text{BATT}} = +2\text{V}$, $V_{\text{OUT}} = +3.3\text{V}$			150		mA
Efficiency		$V_{\text{BATT}} = +2\text{V}$, $V_{\text{OUT}} = +3.3\text{V}$, $I_{\text{LOAD}} = 40\text{mA}$			90		%

Note 1: All units are 100% production tested at $T_{\text{A}} = +25^{\circ}\text{C}$. Limits over the operating temperature range are guaranteed by design and not production tested.

Note 2: Supply current into OUT. This current correlates directly to the actual battery-supply current, but is reduced in value according to the step-up ratio and efficiency.

Typical Operating Characteristics

($V_{OUT} = +3.3V$, $V_{BATT} = +2V$, unless otherwise noted.) (Figure 1)

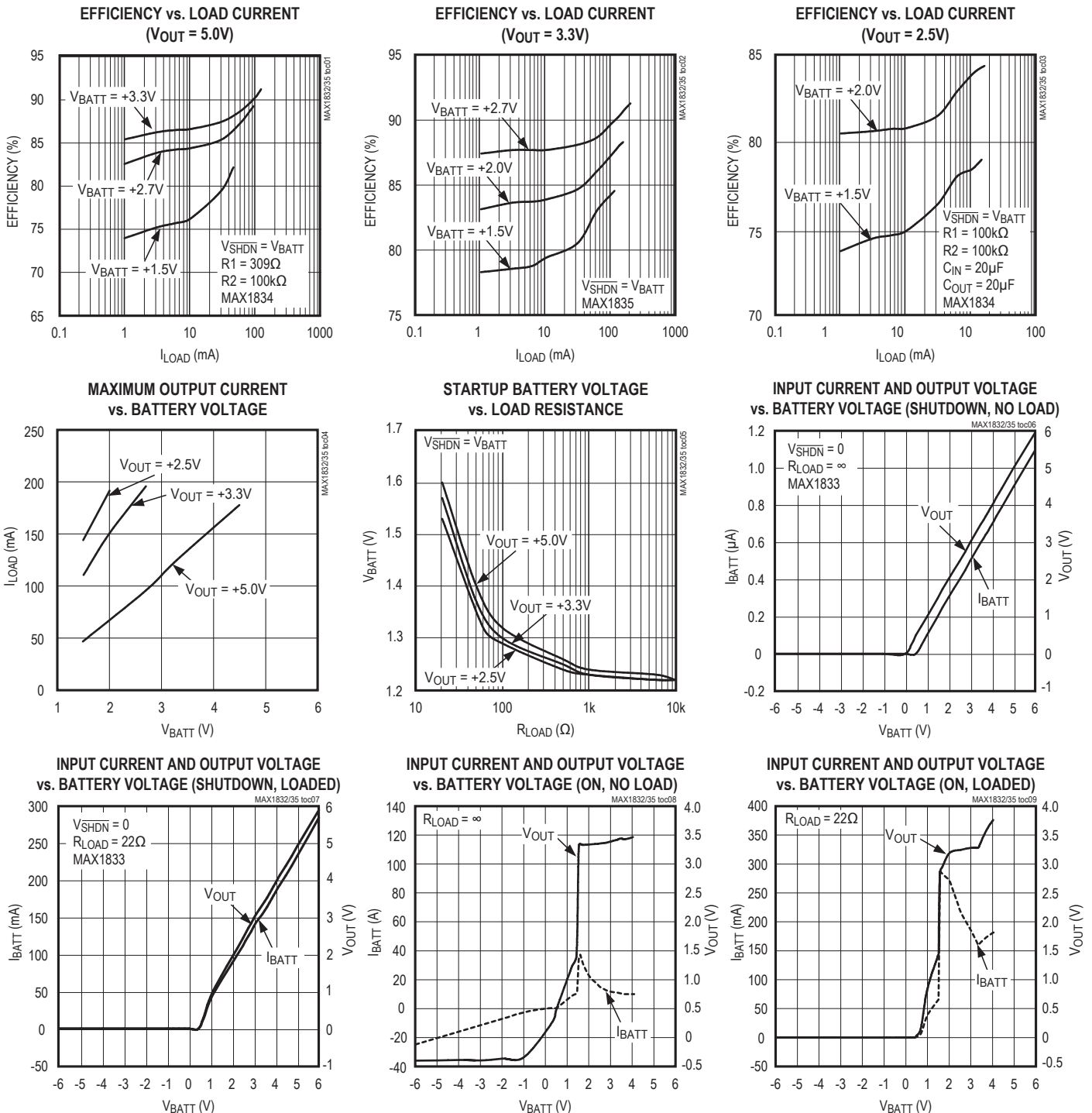

Electrical Characteristics (continued)

($V_{OUT} = +3.3V$, $V_{BATT} = +2V$, unless otherwise noted.) (Figure 1)

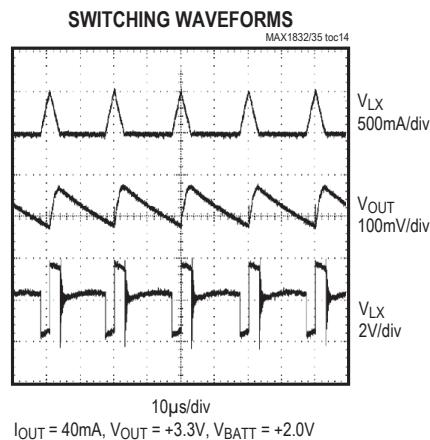
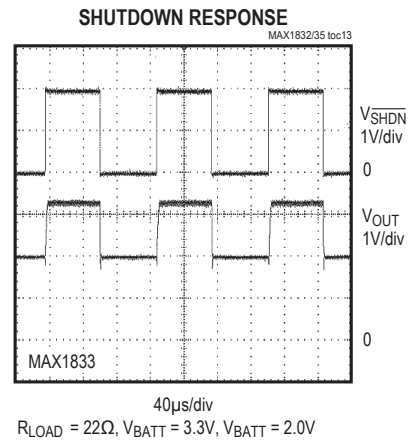
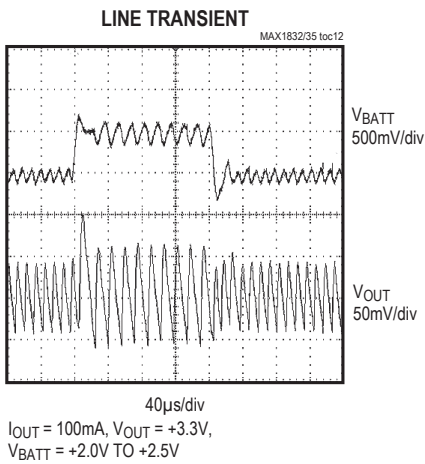
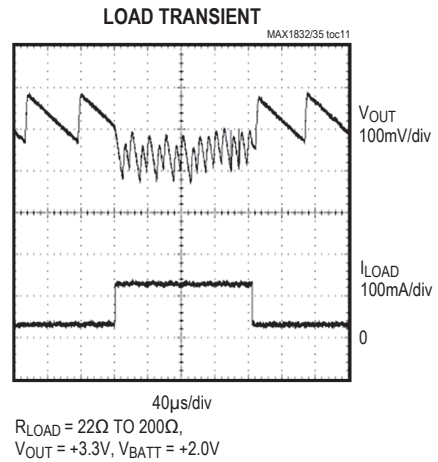
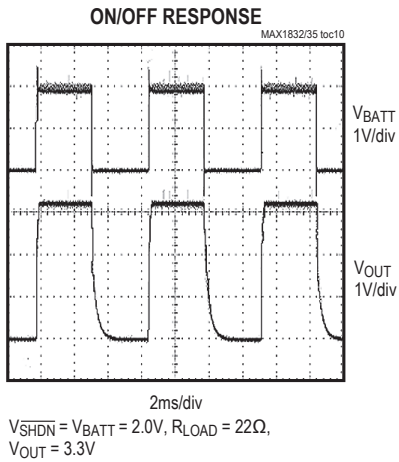

Pin Description

PIN		NAME	FUNCTION
MAX1832 MAX1834	MAX1833 MAX1835		
1	1	$\overline{\text{SHDN}}$	Shutdown. A high logic level turns on the device. When $\overline{\text{SHDN}}$ is low the part is off, and the current into BATT is typically 0.1 μA . For the MAX1832/MAX1833, the battery is connected to OUT through an internal PFET and the external inductor when SHDN is low. $\overline{\text{SHDN}}$ can be used for low-battery cutoff (1.228V threshold). See <i>Low-Battery Cutoff</i> . $\overline{\text{SHDN}}$ has reverse battery protection.
2	2	BATT	Battery Voltage Connection. BATT has reverse battery protection.
3	3	GND	Ground
4	4	LX	Inductor Connection. N-channel MOSFET switch drain and synchronous rectifier P-channel switch drain. LX has reverse battery protection.
5	5	OUT	Output Voltage. Bootstrapped supply for the device. Output sense point for MAX1833/MAX1835.
6	—	FB	MAX1832/MAX1834 Feedback Input. Set the output voltage through a resistor-divider network. See <i>Setting the Output Voltage</i> .
—	6	$\overline{\text{RST}}$	MAX1833/MAX1835 Power-On Reset Open-Drain Output. $\overline{\text{RST}}$ pulls low when the output is 10% below the regulation point. If not used, connect to GND. $\overline{\text{RST}}$ is high impedance in shutdown.

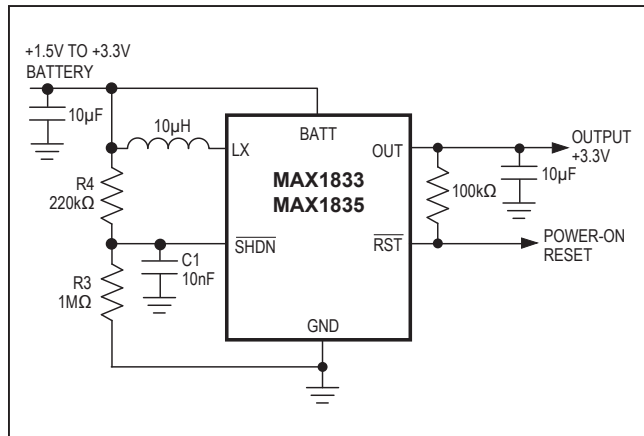

Figure 1a. MAX1833/MAX1835 Typical Operating Circuit

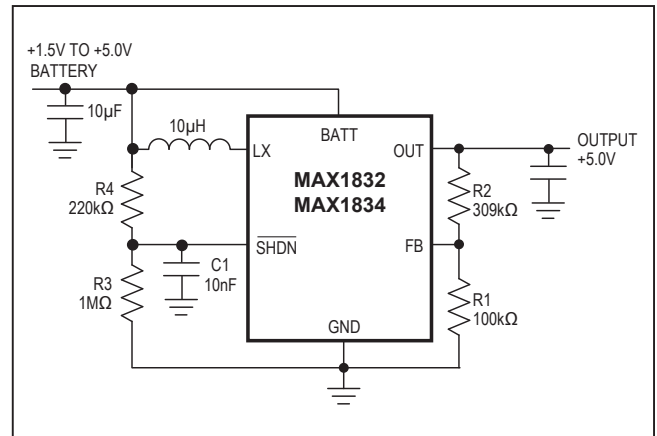

Figure 1b. MAX1832/MAX1834 Typical Operating Circuit

Detailed Description

The MAX1832–MAX1835 compact, high-efficiency step-up converters feature 4 μ A quiescent supply current to ensure the highest possible efficiency over a wide load range. With a minimum +1.5V input voltage, these devices are well suited for applications with two alkaline cells, two nickel-metal-hydride (NiMH) cells, or one lithium ion (Li+) cell. For the MAX1832 and MAX1833, the battery is connected to OUT through the inductor and an internal PFET when SHDN is low. This allows the input battery to be used as a backup or real-time clock supply when the converter is off by eliminating the voltage drop across the PFET body diode.

The MAX1832–MAX1835 are ideal for low-power applications where ultra-small size is critical. These devices feature built-in synchronous rectification that significantly improves efficiency and reduces size and cost by eliminating the need for an external Schottky diode. Furthermore, these devices are the industry's first boost regulators to offer complete reverse battery protection. This proprietary design protects the battery, IC, and the circuitry powered by the IC in the event the input batteries are connected backwards.

Control Scheme

A current-limited control scheme is a key feature of the MAX1832–MAX1835. This scheme provides ultra-low quiescent current and high efficiency over a wide output current range. There is no oscillator. The inductor current is limited by the 0.5A N-channel current limit or by the 5 μ s switch maximum on-time. Following each on-cycle, the inductor current must ramp to zero before another cycle may start. When the error comparator senses that the output has fallen below the regulation threshold, another cycle begins.

An internal synchronous rectifier eliminates the need for an external Schottky diode reducing cost and board space. While the inductor discharges, the P-channel MOSFET turns on and shunts the MOSFET body diode. As a result, the rectifier voltage drop is significantly reduced, improving efficiency without adding external components.

Reverse Battery Protection

The MAX1832–MAX1835 have a unique proprietary design that protects the battery, IC, and circuitry powered by the IC in the event that the input batteries are connected backwards. When the batteries are connected correctly, the reverse battery protection N-channel MOSFET is on and the device operates normally. When the batteries are connected backwards, the reverse battery protection N-channel MOSFET opens, protecting the device and load (Figures 2 and 3). Previously,

this level of protection required additional circuitry and reduced efficiency due to added components in the battery current path.

Applications Information

Shutdown

When $\overline{\text{SHDN}}$ is low, the device is off and no current is drawn from the battery. When $\overline{\text{SHDN}}$ is high, the device is on. If $\overline{\text{SHDN}}$ is driven from a logic-level output, the logic high (on) level should be referenced to V_{OUT} to avoid intermittent turn on. If $\overline{\text{SHDN}}$ is not used at all, connect it to OUT. With $\overline{\text{SHDN}}$ connected to OUT, the MAX1834/MAX1835 startup voltage (1.65V) is slightly higher, due to the voltage across the PFET body diode. The SHDN pin has reverse battery protection.

In shutdown, the MAX1832/MAX1833 connect the battery input to the output through the inductor and the internal synchronous rectifier PFET. This allows the input battery (rather than a separate backup battery) to provide backup power for devices such as an idled microcontroller, SRAM, or real-time clock, without the usual diode forward drop. If the output has a residual voltage during shutdown, a small amount of energy will be transferred from the output back to the input immediately after shutdown. This energy transfer may cause a slight momentary “bump” in the input voltage. The magnitude and duration of the input bump are related to the ratio of C_{IN} and C_{OUT} and the ability of the input to sink current. With battery input sources, the bump will be negligible, but with power-supply inputs (that typically cannot sink current), the bump may be 100s of mV.

In shutdown, the MAX1834/MAX1835 do not turn on the internal PFET and thus do not have an output-to-input current path in shutdown. This allows a separate backup battery, such as a Li+ cell, to be diode-connected at the output, without leakage current flowing to the input. The MAX1834/MAX1835 still have the typical input-to-output current path from the battery to the output, through the PFET body diode, in shutdown.

Low-Battery Cutoff

The $\overline{\text{SHDN}}$ trip threshold of the MAX1832–MAX1835 can be used as a voltage detector, with a resistor-divider, to power down the IC when the battery voltage falls to a set level (Figure 1). The $\overline{\text{SHDN}}$ trip threshold is 1.228V. To use a resistor-divider to set the shutdown voltage, select a value for R_3 in the 100k Ω to 1M Ω range to minimize battery drain. Calculate R_4 as follows:

$$R_4 = R_3 \times (V_{\text{OFF}} / V_{\text{SHDN}} - 1)$$

V_{OFF} is the battery voltage at which the part will shut down and $V_{\text{SHDN}} = 1.228\text{V}$. Note that input ripple can

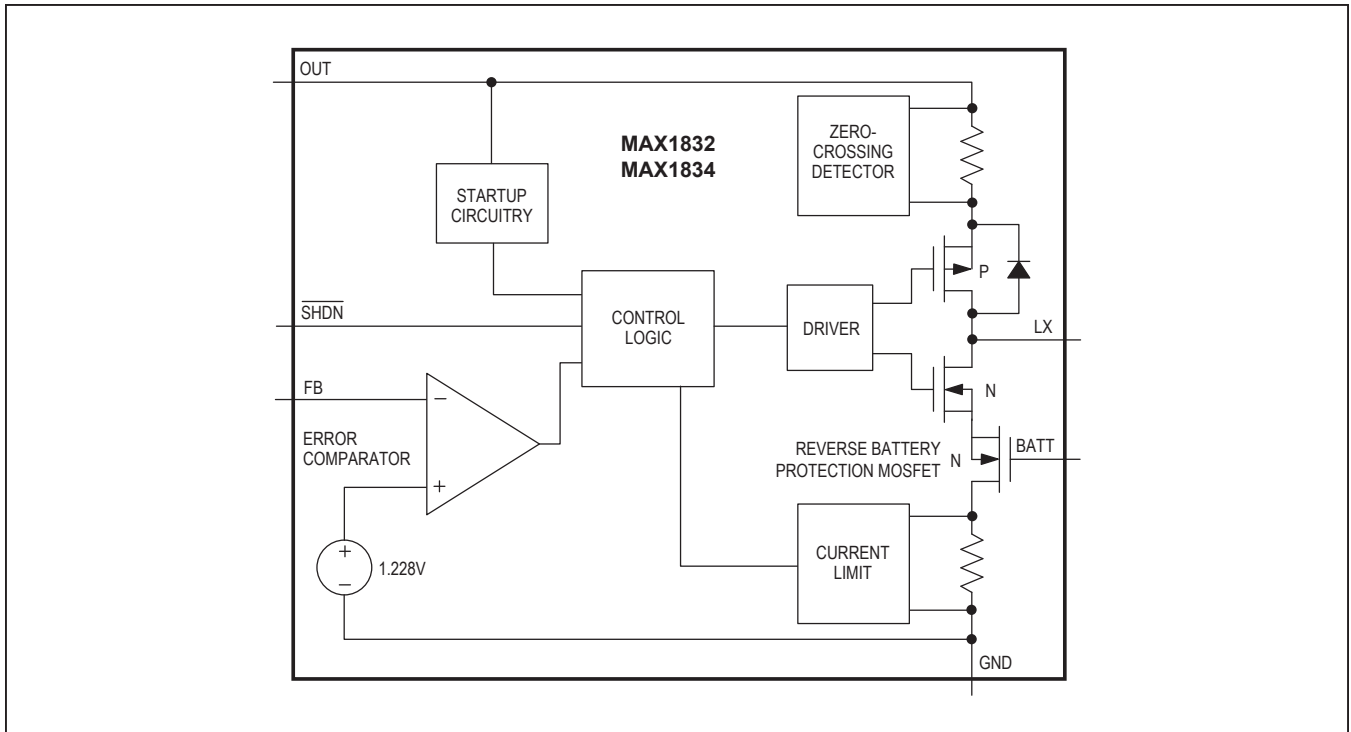

Figure 2. MAX1832/MAX1834 Simplified Functional Diagram

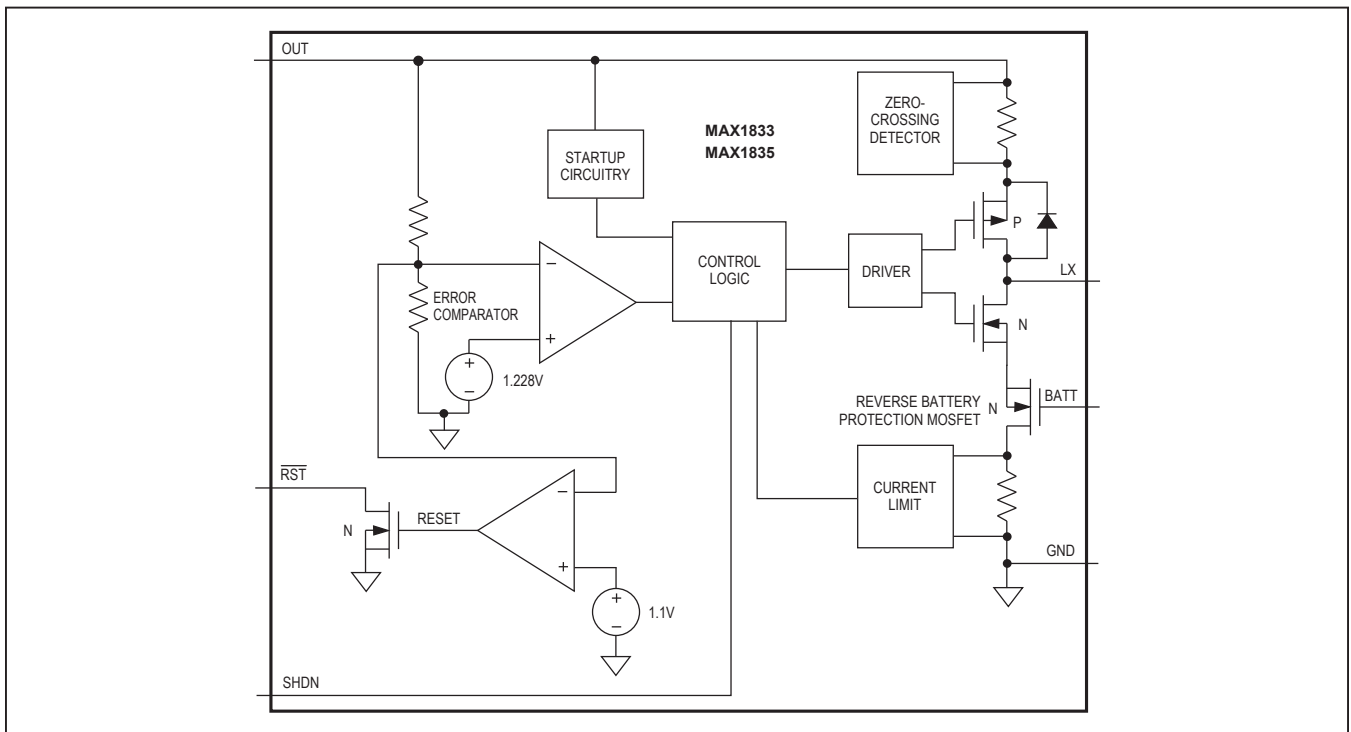

Figure 3. MAX1833/MAX1835 Simplified Functional Diagram

sometimes cause false shutdowns. To minimize the effect of ripple, connect a low-value capacitor (C1) from SHDN to GND to filter out input noise. Select a C1 value such that the R4 x C1 time constant is above 2ms.

Power-On Reset

The MAX1833/MAX1835 provide a power-on reset output (RST). A 100kΩ to 1MΩ pullup resistor from RST to OUT provides a logic control signal. This open-drain output pulls low when the output is 10% below its regulation point. If not used, connect it to GND. RST is high impedance in shutdown.

Setting the Output Voltage

The output voltage of the MAX1832/MAX1834 is adjustable from +2V to +5.5V, using external resistors R1 and R2 (Figure 1b). Since FB leakage is 20nA (max), select feedback resistor R1 to be 100kΩ to 1MΩ. Calculate R2 as follows:

$$R2 = R1 \left(\frac{V_{OUT}}{V_{FB}} - 1 \right)$$

where V_{FB} = 1.228V.

Inductor Selection

The control scheme of the MAX1832–MAX1835 permits flexibility in choosing an inductor. A 10μH inductor performs well for most applications, but values from 4.7μH to 100μH may also be used. Small inductance values typically offer smaller physical size. Large inductance values minimize output ripple but reduce output power. Output power is reduced when the inductance is large enough to prevent the maximum current limit (525mA) from being reached before the maximum on-time (5μs) expires.

For maximum output current, choose L such that:

$$\frac{V_{BATT(MAX)}(1\mu s)}{0.525 A} < L < \frac{V_{BATT(MIN)}(5\mu s)}{0.525 A}$$

$$I_{OUT(MAX)} = \frac{0.525 A}{2} \times \frac{V_{BATT(MIN)} - \frac{0.525 A}{2} (R_{NCH} + R_{IND})}{V_{OUT}}$$

where R_{IND} is the inductor series resistance, and R_{NCH} is the R_{DS(ON)} of the N-channel MOSFET (0.4Ω typ).

Capacitor Selection

Choose an output capacitor to achieve the desired output ripple percentage.

$$C_{OUT} > \frac{0.5 \times L \times 0.525 A^2}{r \% \times V_{OUT}^2}$$

where r is the desired output ripple in %. A 10μF ceramic capacitor is a good starting value. The input capacitor

Table 1. Suggested Inductors and Suppliers

MANUFACTURER	INDUCTOR	PHONE
Coilcraft	DS1608C-103 DO1606T-103	847-639-6400
Sumida	CDRH4D18-100 CR43-100	847-956-0666
Murata	LQH4N100K	814-237-1431

Table 2. Suggested Surface-Mount Capacitors and Manufacturers

VALUE (μF)	DESCRIPTION	MANUFACTURER	PHONE
4.7 to 47	594/595 D-series tantalum	Sprague	603-224-1961
	TAJ, TPS-series tantalum	AVX	803-946-0690
4.7 to 10	X7R ceramic	TDK	847-390-4373
4.7 to 22	X7R ceramic	Taiyo Yuden	408-573-4150

reduces the peak current drawn from the battery and can be the same value as the output capacitor. A larger input capacitor can be used to further reduce ripple and improve efficiency.

PC Board Layout and Grounding

Careful printed circuit layout is important for minimizing ground bounce and noise. Keep the IC's GND pin and the ground leads of the input and output filter capacitors less than 0.2in (5mm) apart. In addition, keep all connections to the FB and LX pins as short as possible. In particular, when using external feedback resistors, locate them as close to FB as possible. To maximize output power and efficiency and minimize output ripple voltage, use a ground plane and solder the IC's GND directly to the ground plane.

Chip Information

TRANSISTOR COUNT: 953

PROCESS: BiCMOS

Package Information

For the latest package outline information and land patterns (footprints), go to www.maximintegrated.com/packages. Note that a “+”, “#”, or “-” in the package code indicates RoHS status only. Package drawings may show a different suffix character, but the drawing pertains to the package regardless of RoHS status.

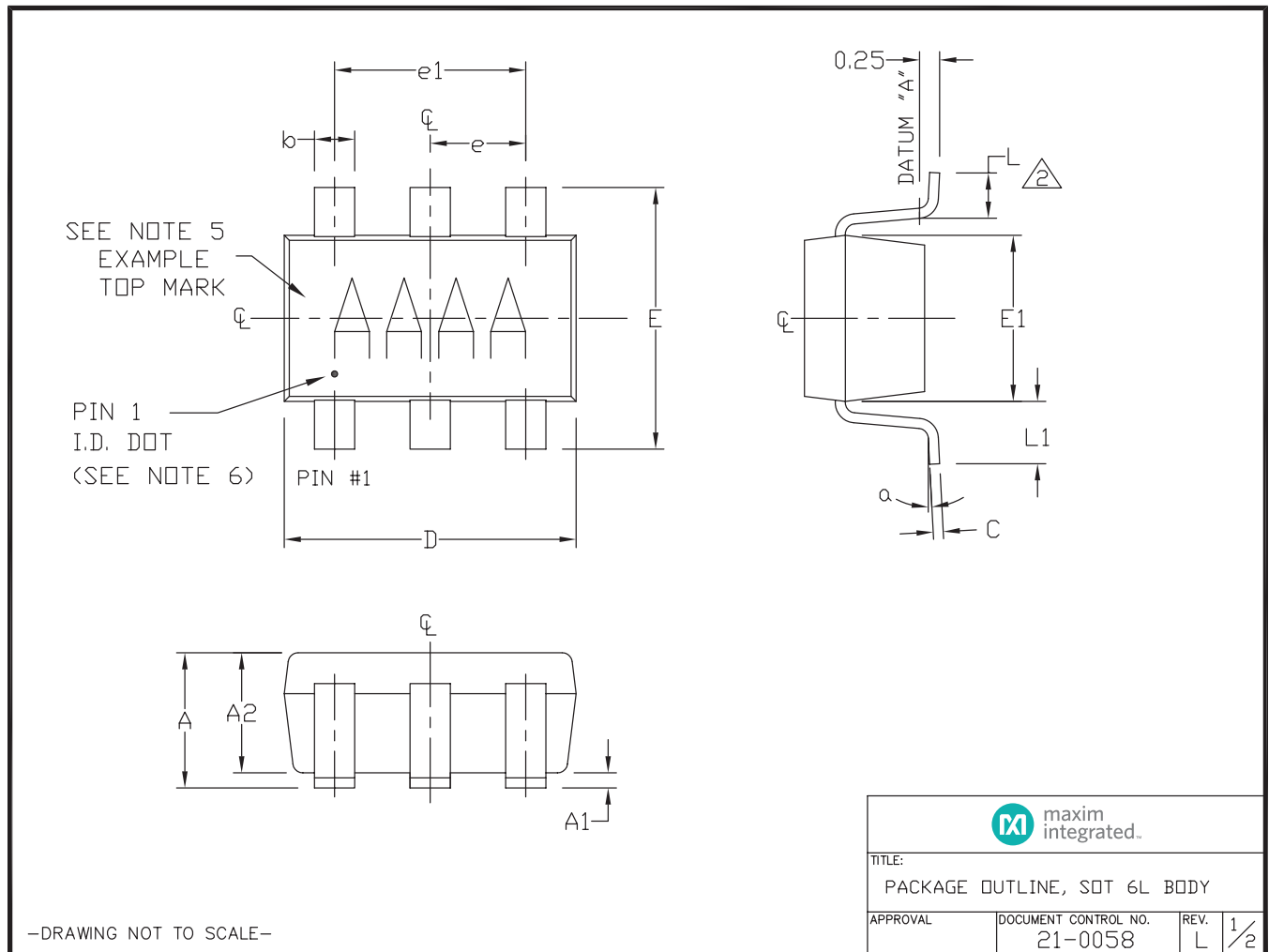

Package Information (continued)

For the latest package outline information and land patterns (footprints), go to www.maximintegrated.com/packages. Note that a “+”, “#”, or “-” in the package code indicates RoHS status only. Package drawings may show a different suffix character, but the drawing pertains to the package regardless of RoHS status.

NOTES:

1. ALL DIMENSIONS ARE IN MILLIMETERS.
2.  FOOT LENGTH MEASURED AT INTERCEPT POINT BETWEEN DATUM A & LEAD SURFACE.
3. PACKAGE OUTLINE EXCLUSIVE OF MOLD FLASH & METAL BURR. MOLD FLASH, PROTRUSION OR METAL BURR SHOULD NOT EXCEED 0.25mm.
4. PACKAGE OUTLINE INCLUSIVE OF SOLDER PLATING.
5. PIN 1 IS LOWER LEFT PIN WHEN READING TOP MARK FROM LEFT TO RIGHT. (SEE EXAMPLE TOP MARK)
6. PIN 1 I.D. DOT IS 0.3mm Ø MIN. LOCATED ABOVE PIN 1.
7. MEETS JEDEC MO178, VARIATION AB.
8. SOLDER THICKNESS MEASURED AT FLAT SECTION OF LEAD BETWEEN 0.08mm AND 0.15mm FROM LEAD TIP.
9. LEAD TO BE COPLANAR WITHIN 0.1mm.
10. NUMBER OF LEADS SHOWN ARE FOR REFERENCE ONLY.
11. MARKING IS FOR PACKAGE ORIENTATION REFERENCE ONLY.
12. ALL DIMENSIONS APPLY TO BOTH LEADED (-) AND PbFREE (+) PKG. CODES.

SYMBOL	MIN	NOMINAL	MAX
A	0.90	1.25	1.45
A1	0.00	0.05	0.15
A2	0.90	1.10	1.30
b	0.35	0.40	0.50
C	0.08	0.15	0.20
D	2.80	2.90	3.00
E	2.60	2.80	3.00
E1	1.50	1.625	1.75
L	0.35	0.45	0.60
L1	0.60 REF.		
e1	1.90 BSC.		
e	0.95 BSC.		
α	0°	2.5°	10°

PKG CODES:
 U6-1, U6-2, U6-4, U6CN-2,
 U6SN-1, U6F-6, U6FH-6; U6FH-7

** U6FH-7 TO BE USED FOR NP42 PARTS ONLY.

–DRAWING NOT TO SCALE–

 maxim integrated.			
TITLE: PACKAGE OUTLINE, SOT 6L BODY			
APPROVAL	DOCUMENT CONTROL NO. 21-0058	REV. L	2/2

Package Information (continued)

For the latest package outline information and land patterns (footprints), go to www.maximintegrated.com/packages. Note that a “+”, “#”, or “-” in the package code indicates RoHS status only. Package drawings may show a different suffix character, but the drawing pertains to the package regardless of RoHS status.

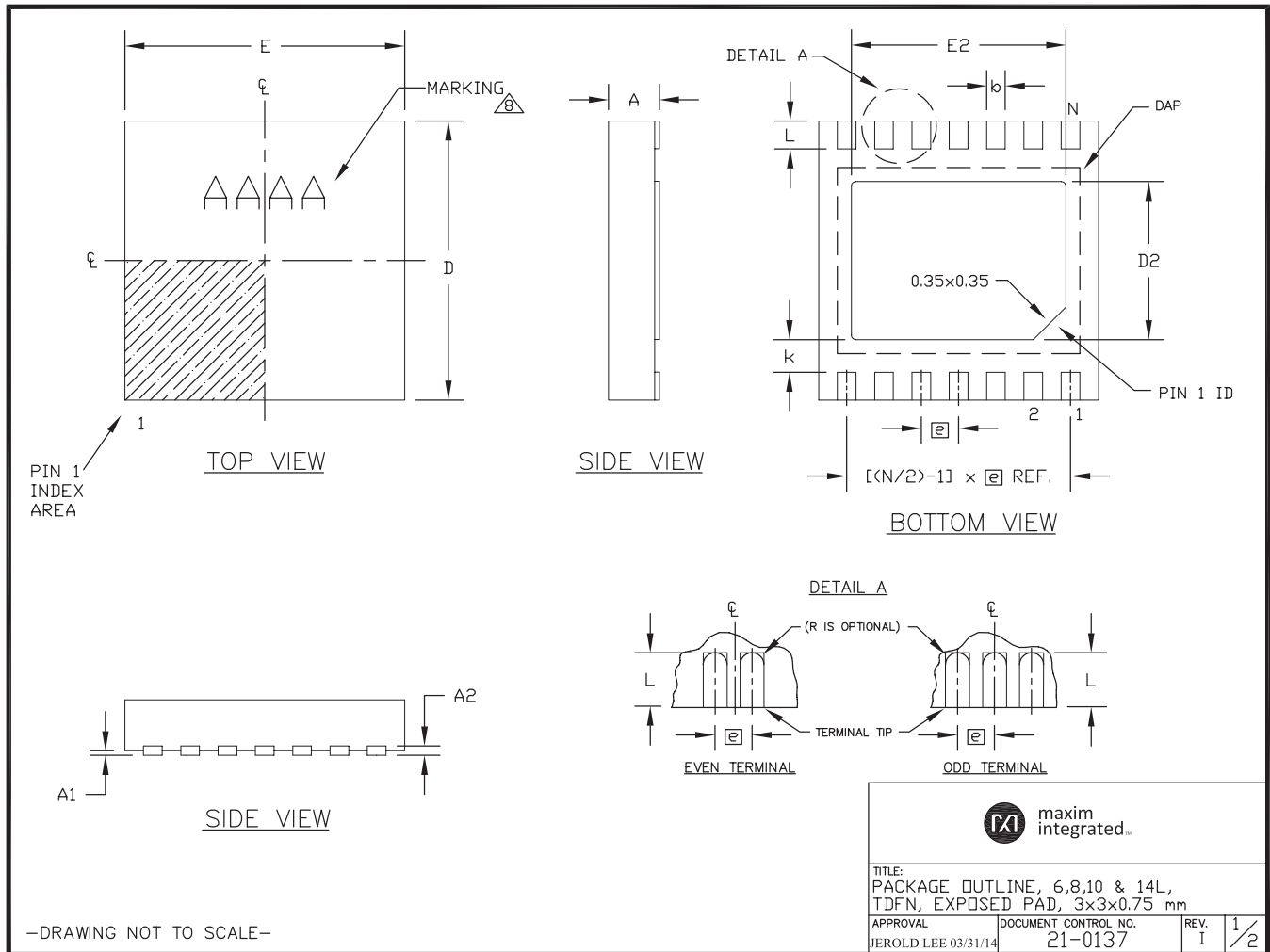

Package Information (continued)

For the latest package outline information and land patterns (footprints), go to www.maximintegrated.com/packages. Note that a "+", "#", or "-" in the package code indicates RoHS status only. Package drawings may show a different suffix character, but the drawing pertains to the package regardless of RoHS status.

COMMON DIMENSIONS			
SYMBOL	MIN.	NOM.	MAX.
A	0.70	0.75	0.80
D	2.90	3.00	3.10
E	2.90	3.00	3.10
A1	0.00	0.025	0.05
L	0.20	0.30	0.40
k	0.25 MIN.		
A2	0.20 REF.		

PACKAGE VARIATIONS								
PKG. CODE	N	D2	E2	e	JEDEC SPEC	b	[(N/2)-1] x e	
T633-2	6	1.50±0.10	2.30±0.10	0.95 BSC	MO229 / WEEA	0.40±0.05	1.90 REF	
T633-2C	6	1.50±0.10	2.30±0.10	0.95 BSC	MO229 / WEEA	0.40±0.05	1.90 REF	
T633MK-1	6	1.50±0.10	2.30±0.10	0.95 BSC	MO229 / WEEA	0.40±0.05	1.90 REF	
T833-2	8	1.50±0.10	2.30±0.10	0.65 BSC	MO229 / WEEC	0.30±0.05	1.95 REF	
T833-2C	8	1.50±0.10	2.30±0.10	0.65 BSC	MO229 / WEEC	0.30±0.05	1.95 REF	
T833-3	8	1.50±0.10	2.30±0.10	0.65 BSC	MO229 / WEEC	0.30±0.05	1.95 REF	
T1033-1	10	1.50±0.10	2.30±0.10	0.50 BSC	MO229 / WEED-3	0.25±0.05	2.00 REF	
T1033-1C	10	1.50±0.10	2.30±0.10	0.50 BSC	MO229 / WEED-3	0.25±0.05	2.00 REF	
T1033MK-1	10	1.50±0.10	2.30±0.10	0.50 BSC	MO229 / WEED-3	0.25±0.05	2.00 REF	
T1033-2	10	1.50±0.10	2.30±0.10	0.50 BSC	MO229 / WEED-3	0.25±0.05	2.00 REF	
T1433-1	14	1.70±0.10	2.30±0.10	0.40 BSC	----	0.20±0.05	2.40 REF	
T1433-2	14	1.70±0.10	2.30±0.10	0.40 BSC	----	0.20±0.05	2.40 REF	
T1433-2C	14	1.70±0.10	2.30±0.10	0.40 BSC	----	0.20±0.05	2.40 REF	
T1433-3F	14	1.70±0.10	2.30±0.10	0.40 BSC	----	0.20±0.05	2.40 REF	

NOTES:

1. ALL DIMENSIONS ARE IN mm. ANGLES IN DEGREES.
2. COPLANARITY SHALL NOT EXCEED 0.08 mm.
3. WARPAGE SHALL NOT EXCEED 0.10 mm.
4. PACKAGE LENGTH/PACKAGE WIDTH ARE CONSIDERED AS SPECIAL CHARACTERISTIC(S).
5. DRAWING CONFORMS TO JEDEC MO229, EXCEPT DIMENSIONS "D2" AND "E2", AND T1433-1 & T1433-2.
6. "N" IS THE TOTAL NUMBER OF LEADS.
7. NUMBER OF LEADS SHOWN ARE FOR REFERENCE ONLY.
8. MARKING IS FOR PACKAGE ORIENTATION REFERENCE ONLY.
9. ALL DIMENSIONS APPLY TO BOTH LEADED (-) AND PbFREE (+) PKG. CODES.

–DRAWING NOT TO SCALE–

 maxim integrated.			
TITLE: PACKAGE OUTLINE, 6,8,10 & 14L, TDFN, EXPOSED PAD, 3x3x0.75 mm			
APPROVAL JEROLD LEE 03/31/14	DOCUMENT CONTROL NO. 21-0137	REV. I	2/2

Revision History



REVISION NUMBER	REVISION DATE	DESCRIPTION	PAGES CHANGED
3	11/18	Updated <i>Ordering Information</i>	1

For pricing, delivery, and ordering information, please visit Maxim Integrated's online storefront at <https://www.maximintegrated.com/en/storefront/storefront.html>.

Maxim Integrated cannot assume responsibility for use of any circuitry other than circuitry entirely embodied in a Maxim Integrated product. No circuit patent licenses are implied. Maxim Integrated reserves the right to change the circuitry and specifications without notice at any time. The parametric values (min and max limits) shown in the Electrical Characteristics table are guaranteed. Other parametric values quoted in this data sheet are provided for guidance.

Looking for pricing, stock, or lifecycle information?

Click below to explore more details on WIN SOURCE:

-  [View MAX1833ETT30-T on WIN SOURCE](#)
-  [Maxim Integrated Information](#)

Optimize Your Supply Chain with WIN SOURCE Solutions

-  Global Sourcing Solution
-  Obsolete Management
-  Cost Control Management
-  Shortage Management
-  Alternative Solution
-  Excess Inventory Management