



**THE DATASHEET OF
MAX1997ETJ+T**





Quintuple/Triple-Output TFT LCD Power Supplies with Fault Protection and VCOM Buffer

MAX1997/MAX1998

General Description

The MAX1997/MAX1998 provide the voltages required for active-matrix, thin-film transistor liquid-crystal displays (TFT LCDs). Both combine a high-performance step-up regulator with two linear-regulator controllers, input protection switch control, and flexible sequence programming. The MAX1997 contains two additional linear-regulator controllers and a VCOM buffer. The MAX1997/MAX1998 can operate from input supplies of 2.7V to 5.5V and feature multiple levels of protection circuitry, making them complete power-supply systems for displays.

The main DC-DC converter provides the regulated supply voltage for the display's source-driver ICs. The converter is a high-frequency (up to 1.5MHz) step-up regulator with an integrated 14V N-channel MOSFET that allows the use of ultra-small inductors and ceramic capacitors while achieving efficiencies over 85%. Its current-mode control architecture provides fast transient response to pulsed loads. Internal soft-start and cycle-by-cycle current limit help prevent input surge currents.

The positive and negative linear-regulator controllers postregulate charge-pump outputs for TFT gate-on and gate-off supplies. Both linear-regulator controllers, as well as the step-up regulator, have supply-sequencing control inputs. The three outputs can be sequenced in any order by selecting the appropriate external components.

The MAX1997 features a high-current backplane driver (VCOM). This buffer provides peak currents exceeding 300mA (typ) and requires only a 0.47 μ F output filter capacitor. The MAX1997's two additional linear-regulator controllers can be used to build the gamma reference voltage and a logic supply.

The MAX1997/MAX1998 have a unique input switch control that can replace the typical input supply fuse. When a fault is detected, the regulator is disconnected from the input supply. The fault detector monitors all the regulated output voltages and the current from the input supply. In addition, the MAX1997/MAX1998 enter shutdown when the internal over-temperature threshold is reached.

The MAX1997 is available in a 32-pin thin QFN package and the MAX1998 is available in a 20-pin thin QFN package. Both packages have a maximum thickness of 0.8mm suitable for ultra-thin LCD panels.

Applications

Notebook Computer Displays
LCD Monitors
Car Navigation Displays

Features

- ◆ 2.7V to 5.5V Input Supply Range
- ◆ Adjustable (Up to +13V) Output Voltage for Source-Driver ICs
- ◆ Integrated High-Efficiency Power MOSFET
- ◆ Linear-Regulator Controllers for TFT Gate-On and Gate-Off Supplies
- ◆ High-Current VCOM Buffer (MAX1997 Only)
- ◆ Two Additional Linear-Regulator Controllers (MAX1997 Only)
- ◆ Programmable Power-Up Sequencing
- ◆ Multiple Overload Protection with Thermal Shutdown
- ◆ 1 μ A Shutdown Current
- ◆ 32-Pin/20-Pin Thin QFN Packages

Ordering Information

PART	TEMP RANGE	PIN-PACKAGE
MAX1997ETJ	-40°C to +85°C	32 Thin QFN 5mm x 5mm
MAX1998ETP	-40°C to +85°C	20 Thin QFN 5mm x 5mm

Pin Configurations

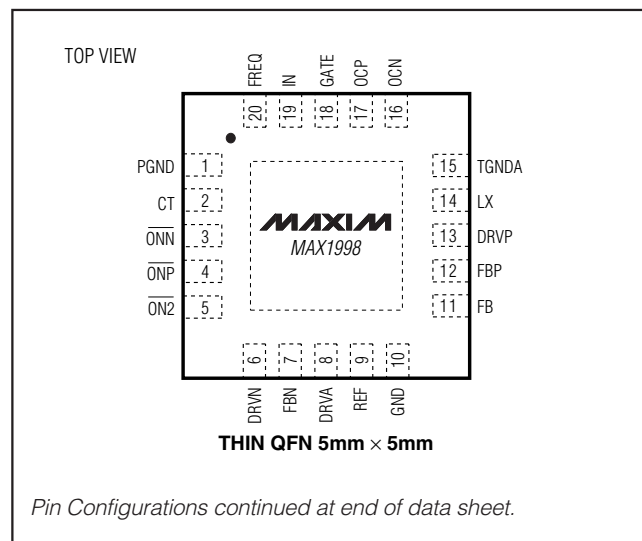

Quintuple/Triple-Output TFT LCD Power Supplies with Fault Protection and VCOM Buffer

ABSOLUTE MAXIMUM RATINGS

IN, $\overline{\text{SHDN}}$, FB, FBP, FBN, FB1, FB2, ONDC, ONP, ONN, ON2, TGND, TGNDB to GND	-0.3V to +6V
PGND to GND	$\pm 0.3V$
LX, V_{DDB} to GND	-0.3V to +14V
DRV1, DRV2, DRVA to GND	-0.3V to +30V
REF, FREQ, GATE, OCN, OCP, CT, PFLT to GND	-0.3V to $V_{\text{IN}} + 0.3V$
DRVN to GND	$V_{\text{IN}} - 28V$ to $V_{\text{IN}} + 0.3V$
FBPB, FBNB, OUTB to GND	-0.3V to $V_{\text{DDB}} + 0.3V$
OUTB Continuous Output Current	$\pm 100\text{mA}$

MAX1997 Continuous Power Dissipation ($T_A = +70^\circ\text{C}$)	
32-Pin Thin QFN (derate 21.2mW/ $^\circ\text{C}$ above $+70^\circ\text{C}$)	1702mW
MAX1998 Continuous Power Dissipation ($T_A = +70^\circ\text{C}$)	
20-Pin Thin QFN (derate 20mW/ $^\circ\text{C}$ above $+70^\circ\text{C}$)	1600mW
Operating Temperature Range	-40°C to $+85^\circ\text{C}$
Junction Temperature	$+150^\circ\text{C}$
Storage Temperature Range	-65°C to $+150^\circ\text{C}$
Lead Temperature (soldering, 10s)	$+300^\circ\text{C}$

Stresses beyond those listed under "Absolute Maximum Ratings" may cause permanent damage to the device. These are stress ratings only, and functional operation of the device at these or any other conditions beyond those indicated in the operational sections of the specifications is not implied. Exposure to absolute maximum rating conditions for extended periods may affect device reliability.

ELECTRICAL CHARACTERISTICS

(Circuit of Figure 1, $V_{\text{IN}} = 3V$, $V_{\text{DDB}} = 10V$, $\overline{\text{SHDN}} = \text{ONDC} = \text{FREQ} = \text{IN}$, $C_{\text{REF}} = 0.22\mu\text{F}$, PGND = GND, $T_A = 0^\circ\text{C}$ to $+85^\circ\text{C}$. Typical values are at $T_A = +25^\circ\text{C}$, unless otherwise noted.)

PARAMETER	CONDITIONS	MIN	TYP	MAX	UNITS	
IN Supply Range		2.7		5.5	V	
IN Undervoltage Lockout Threshold	350mV (typ) hysteresis	V_{IN} rising	2.5	2.7	2.9	V
		V_{IN} falling	2.2	2.35	2.5	
IN Quiescent Current (Note 1)	$V_{\text{FB}} = V_{\text{FBP}} = V_{\text{FB1}} = V_{\text{FB2}} = 1.5V$, $V_{\text{FBN}} = 0$ (MAX1997 only)		0.54	1.25	mA	
	$V_{\text{FB}} = V_{\text{FBP}} = 1.5V$, $V_{\text{FBN}} = 0$ (MAX1998 only)		0.476	1		
IN Shutdown Current	$V_{\overline{\text{SHDN}}} = 0$, $V_{\text{IN}} = 5.5V$		0.1	1	μA	
REF Output Voltage	$-2\mu\text{A} < I_{\text{REF}} < 50\mu\text{A}$	1.231	1.250	1.269	V	
	$-2\mu\text{A} < I_{\text{REF}} < 75\mu\text{A}$	1.225	1.250	1.275		
Thermal Shutdown			160		$^\circ\text{C}$	
OVERCURRENT COMPARATOR						
Input Offset Voltage	$V_{\text{OCN}} = V_{\text{OCP}} = 1.5V$ to $0.8V \times V_{\text{IN}}$	-5		+5	mV	
Input Bias Current	$V_{\text{OCN}} = V_{\text{OCP}} = 0.8V \times V_{\text{IN}}$	-50		+50	nA	
OCN, OCP Input Common-Mode Range		1.5		$0.8 \times V_{\text{IN}}$	V	
FAULT TIMER						
Fault Timer Period	PFLT = GND (MAX1997 only)		21.8		ms	
	PFLT unconnected (MAX1997 only)		43.6			
	PFLT = IN, or MAX1998		87.2			
GATE Output Sink Current During Slew	$V_{\text{GATE}} = 1.5V$ during turn-on transition	5	10	15	μA	
GATE Output Pulldown Resistance	$V_{\text{GATE}} < 0.5V$			200	Ω	
GATE Output Pullup Resistance				200	Ω	
MAIN STEP-UP REGULATOR						
Output Voltage Range		V_{IN}		13	V	
Operating Frequency	FREQ = IN		1.5		MHz	
	FREQ unconnected	0.637	0.75	0.863		
	FREQ = GND		0.375			

Quintuple/Triple-Output TFT LCD Power Supplies with Fault Protection and VCOM Buffer

MAX1997/MAX1998

ELECTRICAL CHARACTERISTICS (continued)

(Circuit of Figure 1, $V_{IN} = 3V$, $V_{DDB} = 10V$, $\overline{SHDN} = ONDC = \text{FREQ} = \text{IN}$, $C_{REF} = 0.22\mu F$, $PGND = GND$, $T_A = 0^\circ C \text{ to } +85^\circ C$. Typical values are at $T_A = +25^\circ C$, unless otherwise noted.)

PARAMETER	CONDITIONS	MIN	TYP	MAX	UNITS
Oscillator Maximum Duty Cycle		80	85	90	%
FB Regulation Voltage	$I_{LX} = 200mA$	1.229	1.242	1.254	V
FB Fault Trip Level	V_{FB} falling	0.96	1.00	1.04	V
FB Load Regulation	$I_{MAIN} = 0$ to full load		-1.6		%
FB Line Regulation	$V_{IN} = 2.7V$ to $5.5V$		0.2	0.4	%/V
FB Input Bias Current	$V_{FB} = 1.5V$	-100		+100	nA
LX On-Resistance			250	450	m Ω
LX Leakage Current	$V_{LX} = 13V$		0.01	20	μA
LX Current Limit		1.6	2.1	2.8	A
LX RMS Current Rating	(Note 2)			1.4	A
Soft-Start Period			$4096/f_{OSC}$		s
Soft-Start Step Size			$V_{REF}/32$		V
POSITIVE LINEAR-REGULATOR CONTROLLERS (REG P, REG 1, AND REG 2)					
FB_ Regulation Voltage	$I_{DRV_P} = 100\mu A$	1.225	1.250	1.275	V
	$I_{DRV_1} = 1350\mu A$ (MAX1997 only)				
	$I_{DRV_2} = 335\mu A$ (MAX1997 only)				
FB_ Fault Trip Level	$V_{FB_}$ falling	0.96	1.00	1.04	V
FB_ Input Bias Current	$V_{FB_} = 1.25V$	-250		+250	nA
FB_ Effective Load Regulation Error (Transconductance)	$V_{DRV_P} = 10V$, $I_{DRV_P} = 0.05mA$ to $1mA$		-1.5	-2	%
	$V_{DRV_1} = 10V$, $I_{DRV_1} = 0.5mA$ to $5mA$ (MAX1997 only)				
	$V_{DRV_2} = 10V$, $I_{DRV_2} = 0.1mA$ to $2mA$ (MAX1997 only)				
FB_ Line (IN) Regulation Error	$I_{DRV_P} = 100\mu A$, $2.7V < V_{IN} < 5.5V$		1		mV
	$I_{DRV_1} = 1350\mu A$, $2.7V < V_{IN} < 5.5V$ (MAX1997 only)				
	$I_{DRV_2} = 335\mu A$, $2.7V < V_{IN} < 5.5V$ (MAX1997 only)				
Bandwidth	(Note 2)	1000			kHz
DRV_P Sink Current	$V_{FB_} = 1.1V$, $V_{DRV_} = 10V$	2	3.3		mA
DRV_1 Sink Current (MAX1997 only)		5	18		
DRV_2 Sink Current (MAX1997 only)		5	15		
DRV_ Leakage Current	$V_{FB_} = 1.5V$, $V_{DRV_} = 28V$		0.1	10	μA
Soft-Start Period			$4096/f_{OSC}$		s
Soft-Start Step Size			$V_{REF}/32$		V
NEGATIVE LINEAR-REGULATOR CONTROLLER (REG N)					
FBN Regulation Voltage	$I_{DRV_N} = 100\mu A$	95	125	155	mV
FBN Fault Trip Level	V_{FBN} rising	325	370	475	mV
FBN Input Bias Current	$V_{FBN} = 0V$	-200		+200	nA

Quintuple/Triple-Output TFT LCD Power Supplies with Fault Protection and VCOM Buffer

ELECTRICAL CHARACTERISTICS (continued)

(Circuit of Figure 1, $V_{IN} = 3V$, $V_{DDB} = 10V$, $\overline{SHDN} = ONDC = \text{FREQ} = \text{IN}$, $C_{REF} = 0.22\mu F$, $PGND = GND$, $T_A = 0^\circ C$ to $+85^\circ C$. Typical values are at $T_A = +25^\circ C$, unless otherwise noted.)

PARAMETER	CONDITIONS	MIN	TYP	MAX	UNITS
FBN Effective Load Regulation Error (Transconductance)	$V_{DRVN} = -10V$, $I_{DRVN} = 50\mu A$ to $1mA$		18	25	mV
FBN Line (IN) Regulation Error	$I_{DRVN} = 100\mu A$, $2.7V < V_{IN} < 5.5V$		1		mV
Bandwidth	(Note 2)	1000			kHz
DRVN Source Current	$V_{FBN} = 200mV$, $V_{DRVN} = -10V$	2	4.2		mA
DRVN Leakage Current	$V_{FBN} = -0.1V$, $V_{DRVN} = -20V$		0.1	10	μA
Soft-Start Period			$4096/f_{OSC}$		s
Soft-Start Step Size			$V_{REF}/32$		V
VCOM BUFFER (MAX1997 only)					
V_{DDB} Supply Range		4.5		13	V
V_{DDB} Supply Current	$V_{FBPB} = V_{FBNB} = 5V$, $V_{DDB} = 9V$		367	900	μA
V_{DDB} Shutdown Current	$V_{DDB} = 13V$, $\overline{SHDN} = ONDC = GND$		3.5	13	μA
Input Offset Voltage	$V_{FBPB} = 2.5V$, no load	-5		+5	mV
Input Bias Current	$V_{FBPB} = V_{FBNB} = 1.2V$ to $V_{DDB} - 1.2V$			1	μA
Input Offset Current	$V_{FBPB} = V_{FBNB} = 1.2V$ to $V_{DDB} - 1.2V$	-100		+100	nA
Input Common-Mode Range	$V_{DDB} = 4.5V$ to $13V$	1.2		$V_{DDB} - 1.2$	V
Power-Supply Rejection Ratio	$V_{DDB} = 4.5V$ to $13V$, $V_{FBPB} = 2.25V$	70			dB
Common-Mode Rejection Ratio	$V_{FBPB} = V_{FBNB} = 1.2V$ to $V_{DDB} - 1.2V$	70			dB
Gain-Bandwidth Product	Small signal		$1/6\pi C_L$		Hz
Load-Transient Settling Time	$R_L = 25\Omega$, $C_L = 10nF$, $V_{DRIVE} = 9V$, settle to within $10mV$ (Note 4)		5		μs
Transconductance	Small signal ($\pm 1mV$ overdrive)		0.3		μS
	Large signal ($\pm 30mV$ overdrive)		7.2		
Output Current Drive	$\pm 100mV$ overdrive, $V_{OUTB} = 3V$ or $7V$	± 150	± 300		mA
LOGIC SIGNALS (\overline{SHDN}, $ONDC$)					
Input Low Voltage	100mV typ hysteresis			0.4	V
Input High Voltage		1.6			V
Input Current			0.01	1	μA
CONTROL INPUTS AND OUTPUTS					
\overline{ONN} , \overline{ONP} , $\overline{ON2}$ Comparator Offset	$V_{\overline{ON}_-} - V_{CT}$, $V_{CT} = 1.25V \pm 50mV$	-50		+50	mV
DRVA Sink Current	$V_{DRVA} = 10V$, $V_{CT} = 1.25V$, $V_{\overline{ON2}} = 2V$	5	11		mA
DRVA Off-Leakage	$V_{DRVA} = 28V$, $V_{CT} = 1.25V$, $V_{\overline{ON2}} = 1V$		0.1	10	μA
CT Source Current	$V_{CT} = 1V$	2.5	5	7.5	μA
CT Discharge Resistance	$V_{CT} = 1V$		15	100	Ω
FREQ, PFLT Input Low Voltage				1	V
FREQ, PFLT Input Middle Voltage			$V_{IN}/2$		
FREQ, PFLT Input High Voltage		$V_{IN} - 1$			V
FREQ, PFLT Input Current	FREQ, PFLT = GND or IN	-50		+50	μA

Quintuple/Triple-Output TFT LCD Power Supplies with Fault Protection and VCOM Buffer

MAX1997/MAX1998

ELECTRICAL CHARACTERISTICS

($V_{IN} = 3V$, $V_{DDB} = 10V$, $\overline{SHDN} = ONDC = \text{FREQ} = \text{IN}$, $C_{REF} = 0.22\mu F$, $PGND = GND$, $T_A = -40^\circ C$ to $+85^\circ C$, unless otherwise noted.)
(Note 3)

PARAMETER	CONDITIONS	MIN	TYP	MAX	UNITS
IN Supply Range		2.7		5.5	V
IN Undervoltage Lockout Threshold	350mV typ hysteresis	V_{IN} rising		2.9	V
		V_{IN} falling		2.5	
IN Quiescent Current (Note 1)	$V_{FB} = V_{FBP} = V_{FB1} = V_{FB2} = 1.5V$, $V_{FBN} = 0$ (MAX1997 only)			1.25	mA
	$V_{FB} = V_{FBP} = 1.5V$, $V_{FBN} = 0$ (MAX1998 only)			1	
REF Output Voltage	$-2\mu A < I_{REF} < 50\mu A$	1.223		1.270	V
	$-2\mu A < I_{REF} < 75\mu A$	1.218		1.280	
OVERCURRENT COMPARATOR					
Input Offset Voltage	$V_{OCN} = V_{OCP} = 1.5V$ to $0.8V \times V_{IN}$	-5		+5	mV
Input Bias Current	$V_{OCN} = V_{OCP} = 0.8V \times V_{IN}$	-50		+50	nA
OCN, OCP Input Common-Mode Range		1.5		$0.8 \times V_{IN}$	V
MAIN STEP-UP REGULATOR					
Output Voltage Range		V_{IN}		13	V
Operating Frequency	FREQ = IN	1		2	MHz
	FREQ unconnected	0.563		0.937	
	FREQ = GND	0.25		0.50	
Oscillator Maximum Duty Cycle		78		92	%
FB Regulation Voltage	$I_{LX} = 200mA$	1.215		1.260	V
FB Fault Trip Level	V_{FB} falling	0.96		1.04	V
FB Input Bias Current	$V_{FB} = 1.5V$	-100		+100	nA
LX On-Resistance				450	m Ω
LX Current Limit		1.6		2.8	A
POSITIVE LINEAR-REGULATOR CONTROLLERS (REG P, REG 1, AND REG 2)					
FB_ Regulation Voltage	$I_{DRV1} = 100\mu A$	1.213		1.288	V
	$I_{DRV1} = 1350\mu A$ (MAX1997 only)				
	$I_{DRV2} = 335\mu A$ (MAX1997 only)				
FB_ Fault Trip Level	$V_{FB_}$ falling	0.96		1.04	V
FB_ Effective Load Regulation Error (Transconductance)	$V_{DRV1} = 10V$, $I_{DRV1} = 0.05mA$ to $1mA$			-2.5	%
	$V_{DRV1} = 10V$, $I_{DRV1} = 0.5mA$ to $5mA$ (MAX1997 only)				
	$V_{DRV2} = 10V$, $I_{DRV2} = 0.1mA$ to $2mA$ (MAX1997 only)				
DRV1 Sink Current (MAX1997 Only)	$V_{FB_} = 1.1V$, $V_{DRV_} = 10V$	1			mA
DRV2 Sink Current (MAX1997 Only)		5			
DRV2 Sink Current (MAX1997 Only)		5			

Quintuple/Triple-Output TFT LCD Power Supplies with Fault Protection and VCOM Buffer

ELECTRICAL CHARACTERISTICS (continued)

($V_{IN} = 3V$, $V_{DDB} = 10V$, $\overline{SHDN} = \overline{ONDC} = \overline{FREQ} = IN$, $C_{REF} = 0.22\mu F$, $PGND = GND$, $T_A = -40^\circ C$ to $+85^\circ C$, unless otherwise noted.)
(Note 3)

PARAMETER	CONDITIONS	MIN	TYP	MAX	UNITS
NEGATIVE LINEAR-REGULATOR CONTROLLER (REG N)					
FBN Regulation Voltage	$I_{DRVN} = 100\mu A$	95		155	mV
FBN Fault Trip Level	V_{FBN} rising	325		475	mV
FBN Effective Load Regulation Error (Transconductance)	$V_{DRVN} = -10V$, $I_{DRVN} = 0.05mA$ to $5mA$			30	mV
DRVN Source Current	$V_{FBN} = 200mV$, $V_{DRVN} = -10V$	1			mA
VCOM BUFFER (MAX1997 only)					
V_{DDB} Supply Range		4.5		13	V
V_{DDB} Supply Current	$V_{FBPB} = V_{FBNB} = 5V$, $V_{DDB} = 9V$			900	μA
Input Offset Voltage	$V_{FBPB} = 2.5V$, no load	-5		+5	mV
Input Bias Current	$V_{FBPB} = V_{FBNB} = 1.2V$ to $V_{DDB} - 1.2V$			1	μA
Input Common-Mode Range	$V_{DDB} = 4.5V$ to $13V$	1.2		$V_{DDB} - 1.2$	V
Out Current Drive	$\pm 100mV$ overdrive, $V_{OUTB} = 3V$ or $7V$	± 150			mA
LOGIC SIGNALS (\overline{SHDN}, \overline{ONDC})					
Input Low Voltage	100mV typ hysteresis			0.4	V
Input High Voltage		1.6			V
CONTROL INPUTS AND OUTPUTS					
FREQ, PFLT Input Low Voltage				1	V
FREQ, PFLT Input High Voltage		$V_{IN} - 1$			V
FREQ, PFLT Input Current	FREQ, PFLT = GND or IN	-50		+50	μA

Note 1: Quiescent current does not include switching losses.

Note 2: Guaranteed by design, not production tested.

Note 3: Specifications to $-40^\circ C$ are guaranteed by design, not production tested.

Note 4: The VCOM buffer load transient settling time is measured with the following circuit:

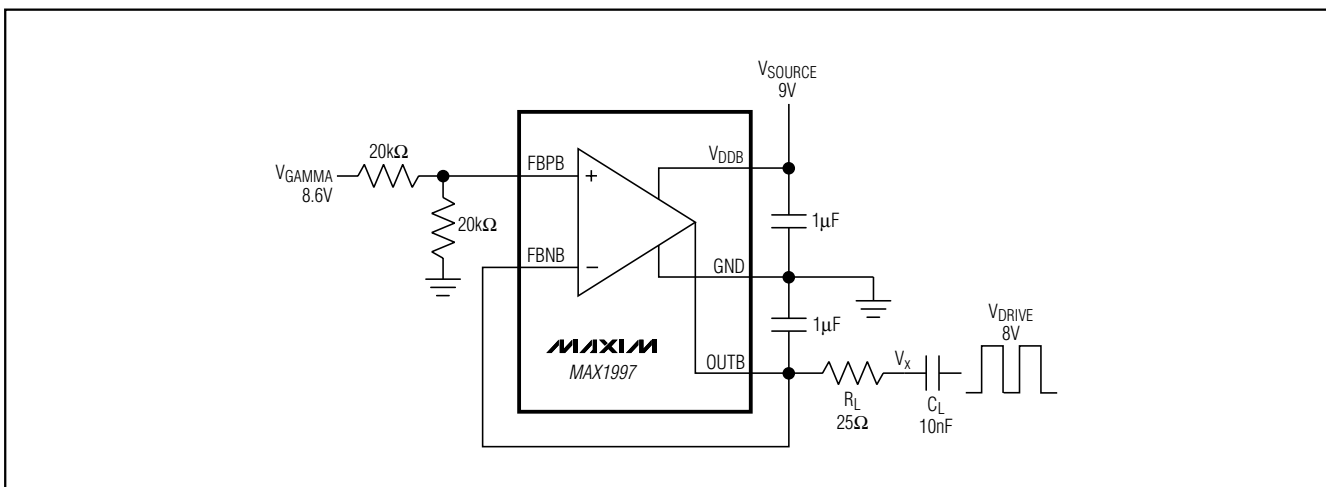

Quintuple/Triple-Output TFT LCD Power Supplies with Fault Protection and VCOM Buffer

Typical Operating Characteristics

(Circuit of Figure 1, $V_{IN} = 3.3V$, $V_{MAIN} = 9V$, $V_{G_ON} = 20V$, $V_{G_OFF} = -7V$, $V_{LOGIC} = 2.5V$, $V_{GAMMA} = 8.6V$, $T_A = +25^\circ C$, unless otherwise noted.)

MAX1997/MAX1998

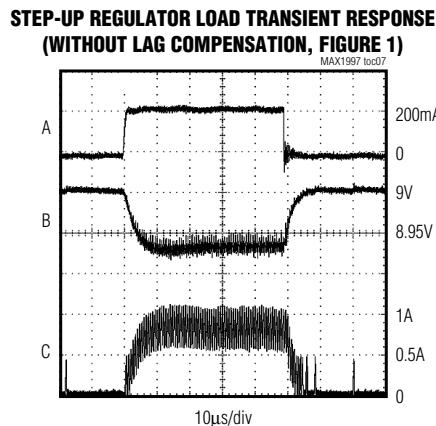
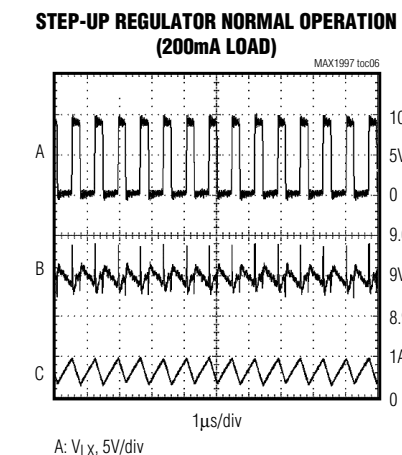
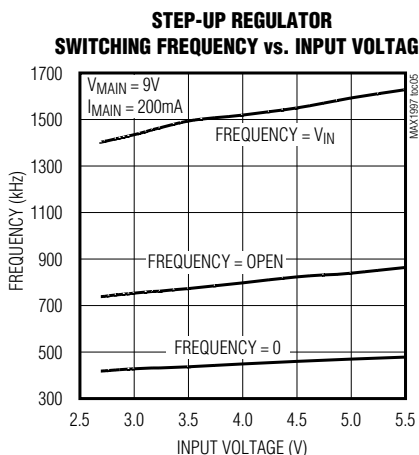
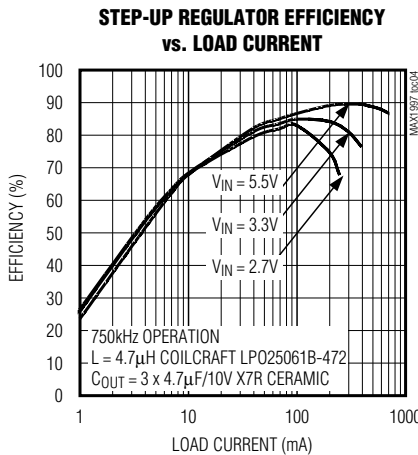
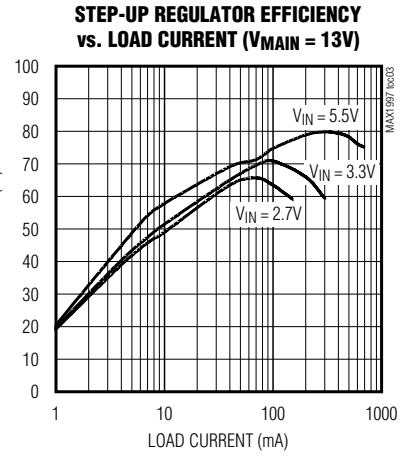
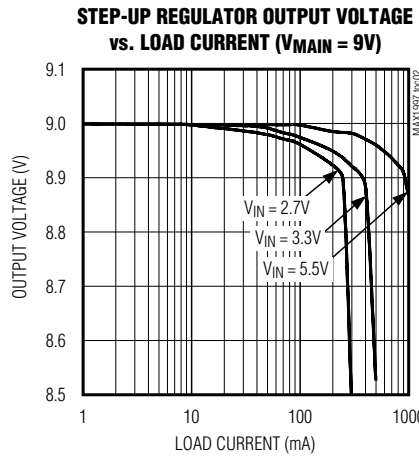
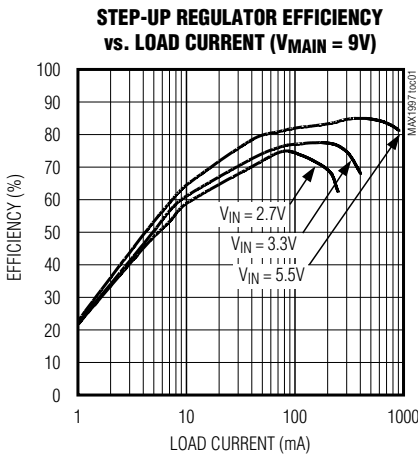

A: $I_{MAIN} = 0$ TO 200mA, 200mA/div
 B: $V_{MAIN} = 9V$, 50mV/div, AC-COUPLED
 C: INDUCTOR CURRENT, 500mA/div

Quintuple/Triple-Output TFT LCD Power Supplies with Fault Protection and VCOM Buffer

Typical Operating Characteristics (continued)

(Circuit of Figure 1, $V_{IN} = 3.3V$, $V_{MAIN} = 9V$, $V_{G_ON} = 20V$, $V_{G_OFF} = -7V$, $V_{LOGIC} = 2.5V$, $V_{GAMMA} = 8.6V$, $T_A = +25^\circ C$, unless otherwise noted.)

STEP-UP REGULATOR LOAD TRANSIENT RESPONSE (WITH LAG COMPENSATION, FIGURE 9)
MAX1997 toc08

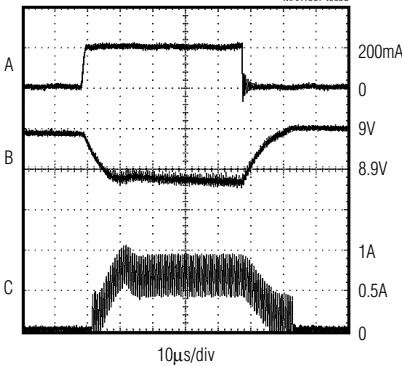

A: $I_{MAIN} = 0$ TO 200mA, 200mA/div
B: $V_{MAIN} = 9V$, 50mV/div, AC-COUPLED
C: INDUCTOR CURRENT, 500mA/div
R7 = 76.8k Ω , R8 = 12.1k Ω , R10 = 1.5k Ω , C10 = 470pF

STEP-UP REGULATOR LOAD TRANSIENT RESPONSE (2µs PULSES) (WITHOUT LAG COMPENSATION, FIGURE 1)
MAX1997 toc09

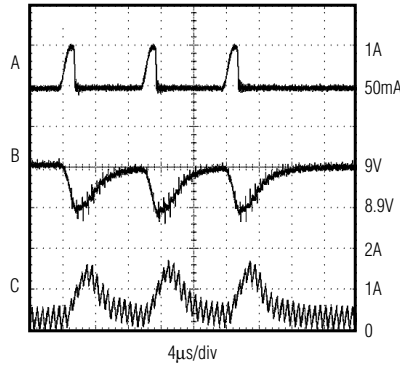

A: $I_{MAIN} = 50mA$ TO 1A, 1A/div
B: $V_{MAIN} = 9V$, 100mV/div, AC-COUPLED
C: INDUCTOR CURRENT, 1A/div

STEP-UP REGULATOR LOAD TRANSIENT RESPONSE (2µs PULSES) (WITH LAG COMPENSATION, FIGURE 9)
MAX1997 toc10

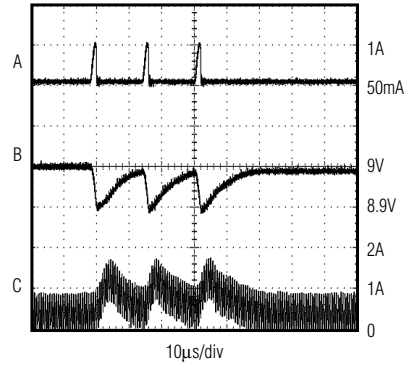

A: $I_{MAIN} = 50mA$ TO 1A, 1A/div
B: $V_{MAIN} = 9V$, 100mV/div, AC-COUPLED
C: INDUCTOR CURRENT, 1A/div
R7 = 76.8k Ω , R8 = 12.1k Ω , R10 = 1.5k Ω , C10 = 470pF

STEP-UP REGULATOR SOFT-START
MAX1997 toc11

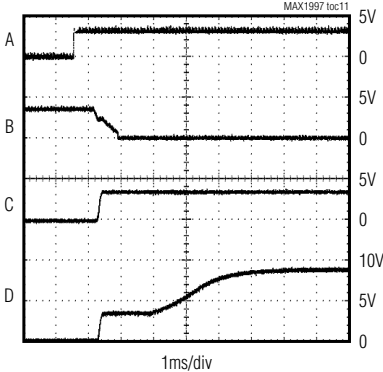

A: V_{SHDN} , 5V/div
B: V_{GATE} , 5V/div
C: V_{DRAIN} , 5V/div
D: V_{MAIN} , 5V/div

POWER-UP SEQUENCE
MAX1997 toc12

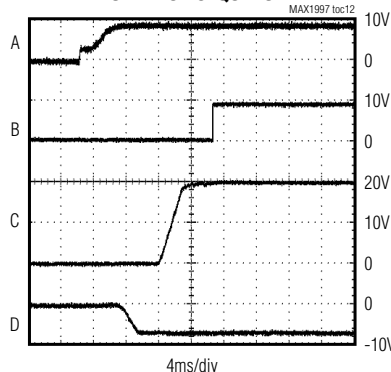

A: V_{MAIN} , 10V/div
B: V_{SOURCE} , 10V/div
C: V_{GATE_ON} , 10V/div
D: V_{GATE_OFF} , 10V/div
 $V_{ONN} < V_{ONP} < V_{ON2}$

POWER-UP SEQUENCE
MAX1997 toc13

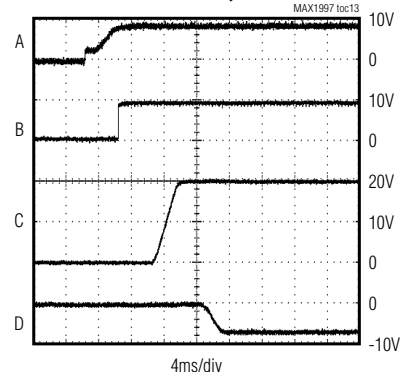

A: V_{MAIN} , 10V/div
B: V_{SOURCE} , 10V/div
C: V_{GATE_ON} , 10V/div
D: V_{GATE_OFF} , 10V/div
 $V_{ONN} > V_{ONP} > V_{ON2}$

Quintuple/Triple-Output TFT LCD Power Supplies with Fault Protection and VCOM Buffer

Typical Operating Characteristics (continued)

(Circuit of Figure 1, $V_{IN} = 3.3V$, $V_{MAIN} = 9V$, $V_{G_ON} = 20V$, $V_{G_OFF} = -7V$, $V_{LOGIC} = 2.5V$, $V_{GAMMA} = 8.6V$, $T_A = +25^\circ C$, unless otherwise noted.)

MAX1997/MAX1998

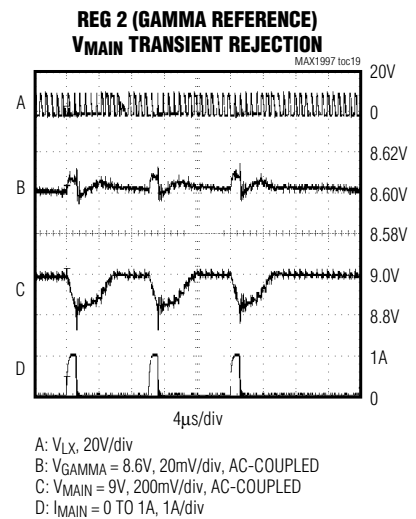
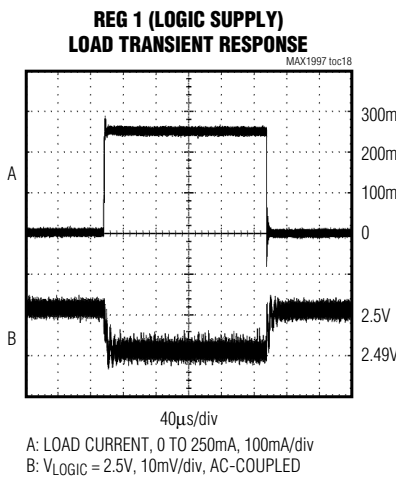
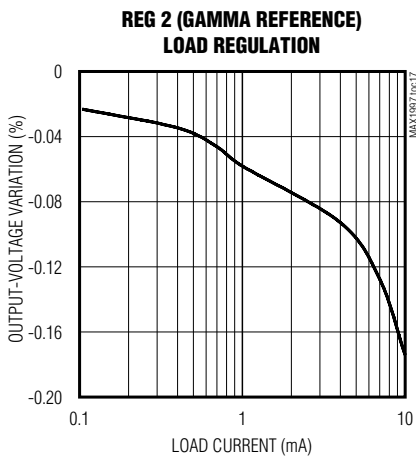
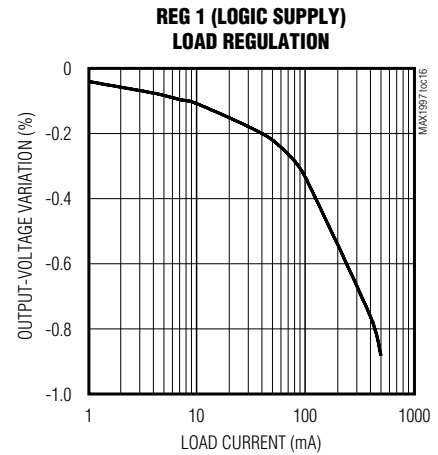
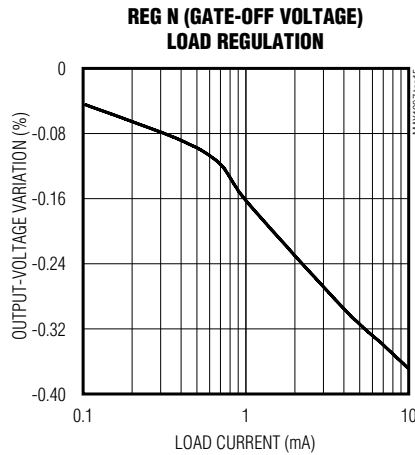
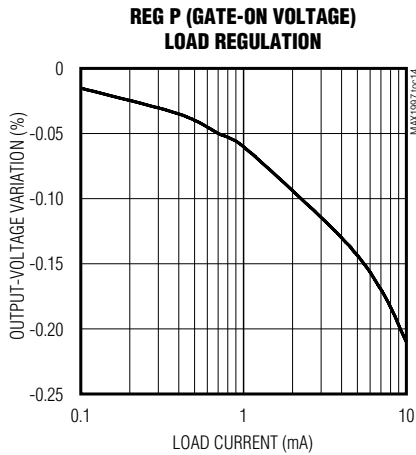

Quintuple/Triple-Output TFT LCD Power Supplies with Fault Protection and VCOM Buffer

Typical Operating Characteristics (continued)

(Circuit of Figure 1, $V_{IN} = 3.3V$, $V_{MAIN} = 9V$, $V_{G_ON} = 20V$, $V_{G_OFF} = -7V$, $V_{LOGIC} = 2.5V$, $V_{GAMMA} = 8.6V$, $T_A = +25^\circ C$, unless otherwise noted.)

OVERCURRENT PROTECTION RESPONSE TO OVERLOAD DURING STARTUP

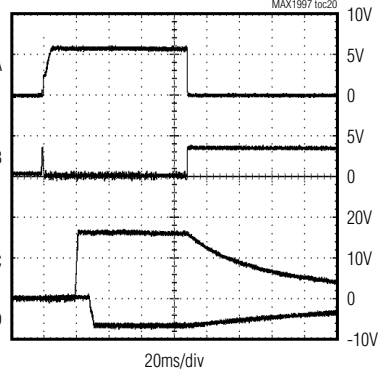

A: V_{MAIN} , 5V/div
 B: V_{GATE} , 5V/div
 C: V_{G_ON} , 10V/div
 D: V_{G_OFF} , 10V/div

OVERCURRENT PROTECTION RESPONSE TO OVERLOAD DURING NORMAL OPERATION

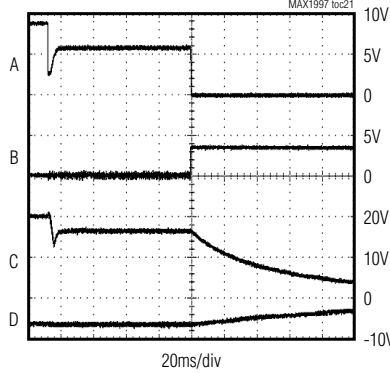

A: V_{MAIN} , 5V/div
 B: V_{GATE} , 5V/div
 C: V_{G_ON} , 10V/div
 D: V_{G_OFF} , 10V/div

REFERENCE VOLTAGE vs. LOAD CURRENT

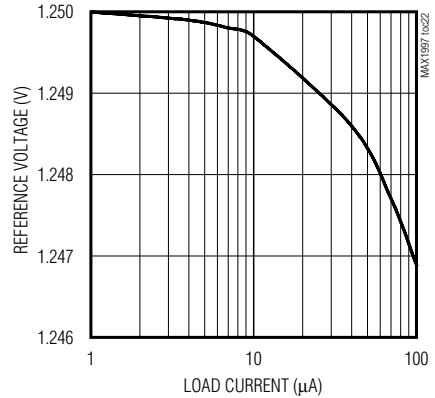

LX CURRENT LIMIT vs. INPUT VOLTAGE

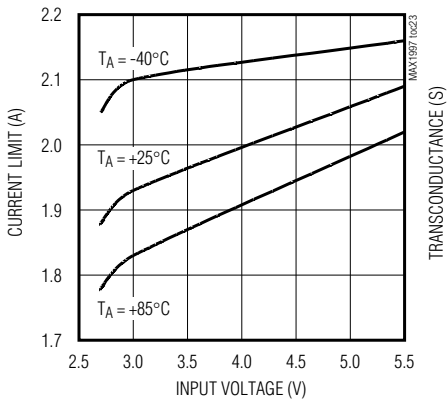

VCOM BUFFER TRANSCONDUCTANCE vs. TEMPERATURE

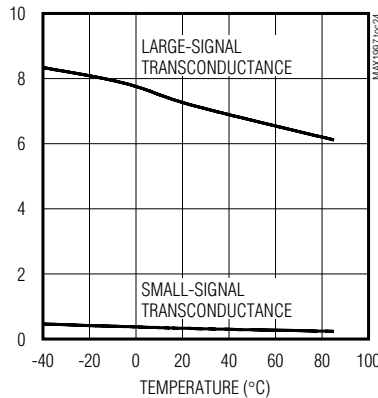

VCOM LOAD TRANSIENT RESPONSE (CIRCUIT OF PAGE 6, NOTE 4)

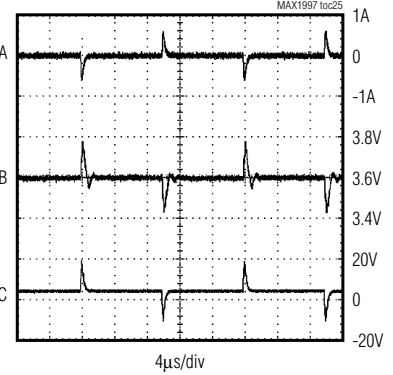

A: LOAD CURRENT, 1A/div
 B: $V_{OUTB} = 3.6V$, 200mV/div, AC-COUPLED
 C: V_x , 20V/div

Pin Description

PIN		NAME	FUNCTION
MAX1997	MAX1998		
1	—	TGNDB	Internal Connection. Connect this pin to ground. Do not leave this pin floating.
2	1	PGND	Power Ground. PGND is the source of the N-channel power MOSFET. Connect PGND to the star ground at the device's backside pad.
3	—	DRV1	Logic Linear-Regulator (REG 1) Base Drive. Open drain of an internal N-channel MOSFET. Connect DRV1 to the base of an external PNP linear regulator pass transistor. (See the <i>Pass Transistor Selection</i> section).

Quintuple/Triple-Output TFT LCD Power Supplies with Fault Protection and VCOM Buffer

Pin Description (continued)

MAX1997/MAX1998

PIN		NAME	FUNCTION
MAX1997	MAX1998		
4	—	FB1	Logic Linear-Regulator (REG 1) Feedback Input. FB1 regulates at 1.25V nominal. Connect FB1 to the center tap of a resistive voltage-divider between the REG 1 output and the analog ground (GND) to set the output voltage. Place the resistive voltage-divider close to the pin.
5	2	CT	Sequence Timing Control Input. Connect a capacitor from this pin to GND. This timing capacitor controls the turn-on of REG P, REG N, REG 2, and DRVA. The sequence timing block is enabled, together with the main step-up regulator, when ONDC goes high. Then an internal 5 μ A current source charges the timing capacitor from 0V to V_{IN} , which sets the turn-on delay. A discharge switch keeps CT at GND when the sequence timing block is disabled. (See the <i>Power-Up Sequencing and Inrush Current Control</i> section.)
6	3	\overline{ONN}	Gate-Off Linear-Regulator (REG N) Sequence Control Input. REG N is enabled when \overline{SHDN} is high, the gate to the input P-channel MOSFET is low, ONDC is high, and $V_{CT} > V_{\overline{ONN}}$. (See the <i>Power-Up Sequencing and Inrush Current Control</i> section.)
7	4	\overline{ONP}	Gate-On Linear-Regulator (REG P) Sequence Control Input. REG P is enabled when \overline{SHDN} is high, the gate to the input P-channel MOSFET is low, ONDC is high, and $V_{CT} > V_{\overline{ONP}}$. (See the <i>Power-Up Sequencing and Inrush Current Control</i> section.)
8	5	$\overline{ON2}$	Gamma Linear-Regulator (REG 2) Sequence Control Input. REG 2 is enabled when \overline{SHDN} is high, the gate to the input P-channel MOSFET is low, ONDC is high, and $V_{CT} > V_{\overline{ON2}}$. $\overline{ON2}$ also controls the DRVA open-drain output, which is typically used to turn on an N-channel MOSFET between the step-up regulator output and the source driver ICs' supply pins. (See the <i>Power-Up Sequencing and Inrush Current Control</i> section.)
9	6	DRVN	Gate-Off Linear-Regulator (REG N) Base Drive. Open drain of an internal P-channel MOSFET. Connect DRVN to the base of an external NPN linear regulator pass transistor. (See the <i>Pass Transistor Selection</i> section.)
10	7	FBN	Gate-Off Linear-Regulator (REG N) Feedback Input. FBN regulates to 125mV nominal. Connect FBN to the center tap of a resistive voltage-divider between the REG N output and the reference voltage (REF) to set the output voltage. Place the resistive voltage-divider close to the pin.
11	8	DRVA	Open-Drain Sequence Output. The DRVA open-drain output is controlled by $\overline{ON2}$. DRVA is typically used to turn on an N-channel MOSFET between the step-up regulator output and the source-driver ICs' supply pins. DRVA is high impedance when \overline{SHDN} is high, the gate to the input P-channel MOSFET is low, ONDC is high, and $V_{CT} > V_{\overline{ON2}}$. Otherwise, DRVA connects to ground. (See the <i>Power-Up Sequencing and Inrush Current Control</i> section.)
12	9	REF	Internal Reference Bypass Terminal. Connect a 0.22 μ F ceramic capacitor from REF to the analog ground (GND). External load capability is at least 75 μ A.
13	10	GND	Analog Ground.
14	—	FBNB	VCOM Buffer Inverting Input. (See the <i>VCOM Buffer</i> section.)
15	—	OUTB	VCOM Buffer Output. Requires a minimum 0.47 μ F ceramic filter capacitor to GND. Place the capacitor as close as possible to OUTB.
16	—	V _{DDB}	VCOM Buffer Supply Input. Bypass to GND with a 0.47 μ F capacitor as close as possible to the pin.
17	—	FBPB	VCOM Buffer Noninverting Input. (See the <i>VCOM Buffer</i> section.)
18	—	FB2	Gamma Linear-Regulator (REG 2) Feedback Input. FBP regulates to 1.25V nominal. Connect FB2 to the center tap of a resistive voltage-divider between the REG 2 output and the analog ground (GND) to set the output voltage. Place the divider close to the pin.

Quintuple/Triple-Output TFT LCD Power Supplies with Fault Protection and VCOM Buffer

Pin Description (continued)

PIN		NAME	FUNCTION
MAX1997	MAX1998		
19	—	DRV2	Gamma Linear-Regulator (REG 2) Base Drive. Open drain of an internal N-channel MOSFET. Connect DRV2 to the base of an external PNP linear regulator pass transistor. (See the <i>Pass Transistor Selection</i> section.)
20	11	FB	Main Step-Up Regulator Feedback Input. Connect FB to the center tap of a resistive voltage-divider between the main output (V_{MAIN}) and the analog ground (GND) to set the main step-up regulator output voltage. (See the <i>Main Step-Up Regulator, Output Voltage Selection</i> section.) Place the resistive voltage-divider close to the pin.
21	12	FBP	Gate-On Linear-Regulator (REG P) Feedback Input. FBP regulates to 1.25V nominal. Connect FBP to the center tap of a resistive voltage-divider between the REG P output and the analog ground (GND) to set the output voltage. Place the resistive voltage-divider close to the pin.
22	13	DRVP	Gate-On Linear-Regulator (REG P) Base Drive. Open drain of an internal N-channel MOSFET. Connect DRVP to the base of an external PNP linear-regulator pass transistor. (See the <i>Pass Transistor Selection</i> section.)
23	14	LX	Switching Node. Drain of the internal N-channel power MOSFET for the main step-up regulator.
24	15	TGND	Internal Connection. Connect this pin to ground. Do not leave this pin floating.
25	16	OCN	Overcurrent Comparator Inverting Input. Connect OCN to the center tap of a resistive voltage-divider connected to the drain of the external input protection P-channel MOSFET. (See the <i>Input Overcurrent Protection</i> section.) If unused, connect OCN to REF.
26	17	OCP	Overcurrent Comparator Noninverting Input. Connect OCP to the center tap of a resistive voltage-divider connected to the source of the external input protection P-channel MOSFET. The voltage on OCP sets the input overcurrent threshold. (See the <i>Input Overcurrent Protection</i> section.) If unused, connect OCP to GND.
27	18	GATE	Gate-Drive Output to the External Input Protection P-Channel MOSFET. (See the <i>Input Overcurrent Protection</i> section.) If unused, leave GATE unconnected.
28	—	PFLT	Fault Timer Select Input. Pull PFLT above its logic high threshold ($0.7 \times V_{IN}$) to set the fault delay period to 87ms. Pull PFLT below its logic low threshold ($0.3 \times V_{IN}$) to set the fault delay period to 22ms. Leave PFLT unconnected to set the fault delay period to 44ms. The fault delay period for the MAX1998 is fixed at 87ms.
29	19	IN	Supply Input. The supply voltage powers all the control circuitry. The input voltage range is from 2.7V to 5.5V. Bypass IN to GND with a 0.47 μ F ceramic capacitor. Place the capacitor within 5mm of IN.
30	—	ONDC	Step-Up Regulator Logic Control Input. The step-up regulator, VCOM buffer, and the sequence timing block are enabled when ONDC is high and disabled when ONDC is low.
31	20	FREQ	Frequency Select Input. Pull FREQ above its logic high threshold ($0.7 \times V_{IN}$) to set the main step-up regulator switching frequency to 1.5MHz. Pull FREQ below its logic low threshold ($0.3 \times V_{IN}$) to set the frequency to 375kHz. Leave FREQ unconnected to set the frequency to 750kHz.
32	—	$\overline{\text{SHDN}}$	Active-Low Shutdown Control Input. All the sections of the device are disabled and the GATE pin goes high when $\overline{\text{SHDN}}$ is below its 0.4V logic low threshold. Pull $\overline{\text{SHDN}}$ above its 1.6V logic high threshold to enable the device. Do not leave $\overline{\text{SHDN}}$ unconnected.

Quintuple/Triple-Output TFT LCD Power Supplies with Fault Protection and VCOM Buffer

MAX1997/MAX1998

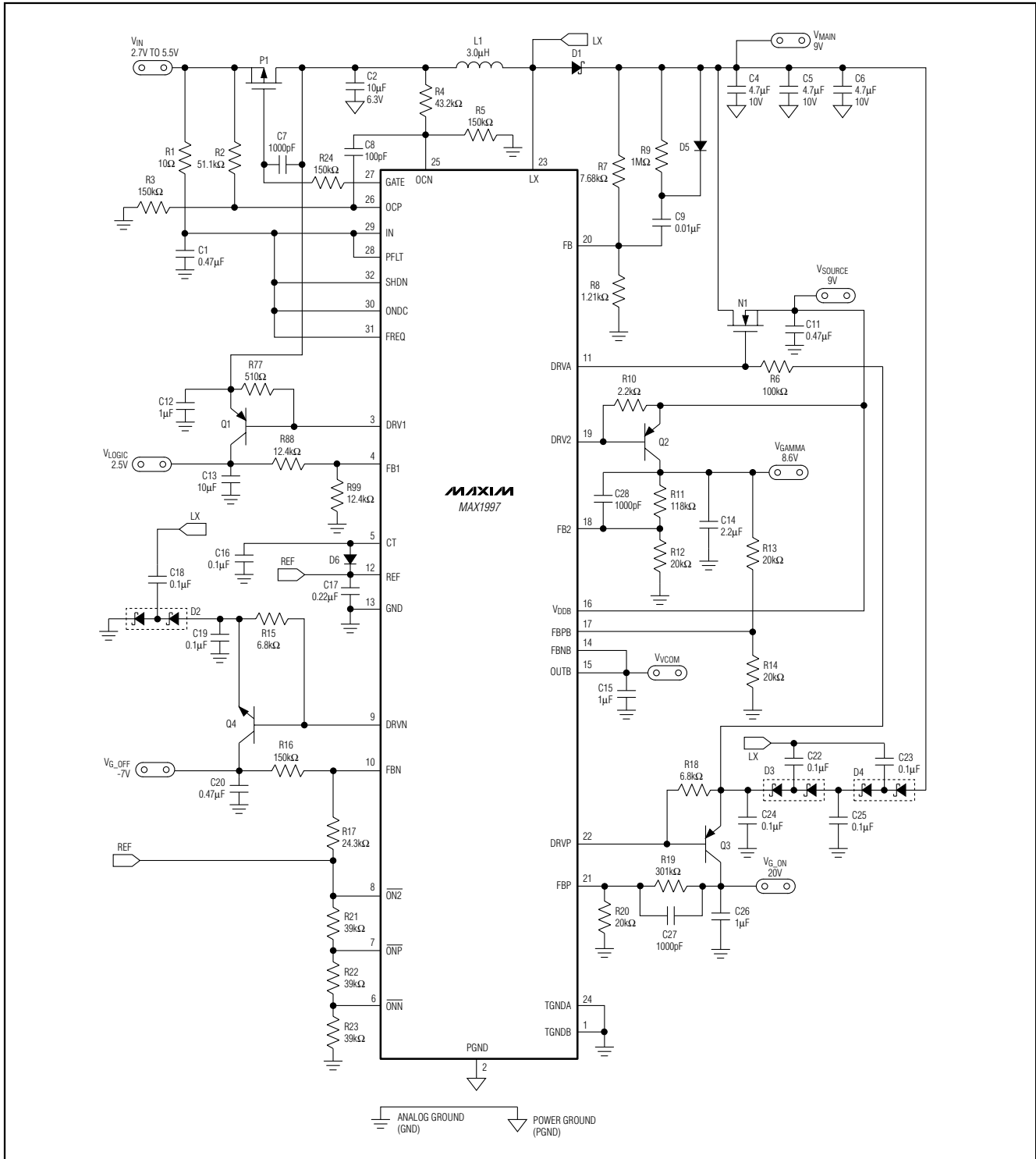

Figure 1. Standard Application Circuit

Quintuple/Triple-Output TFT LCD Power Supplies with Fault Protection and VCOM Buffer

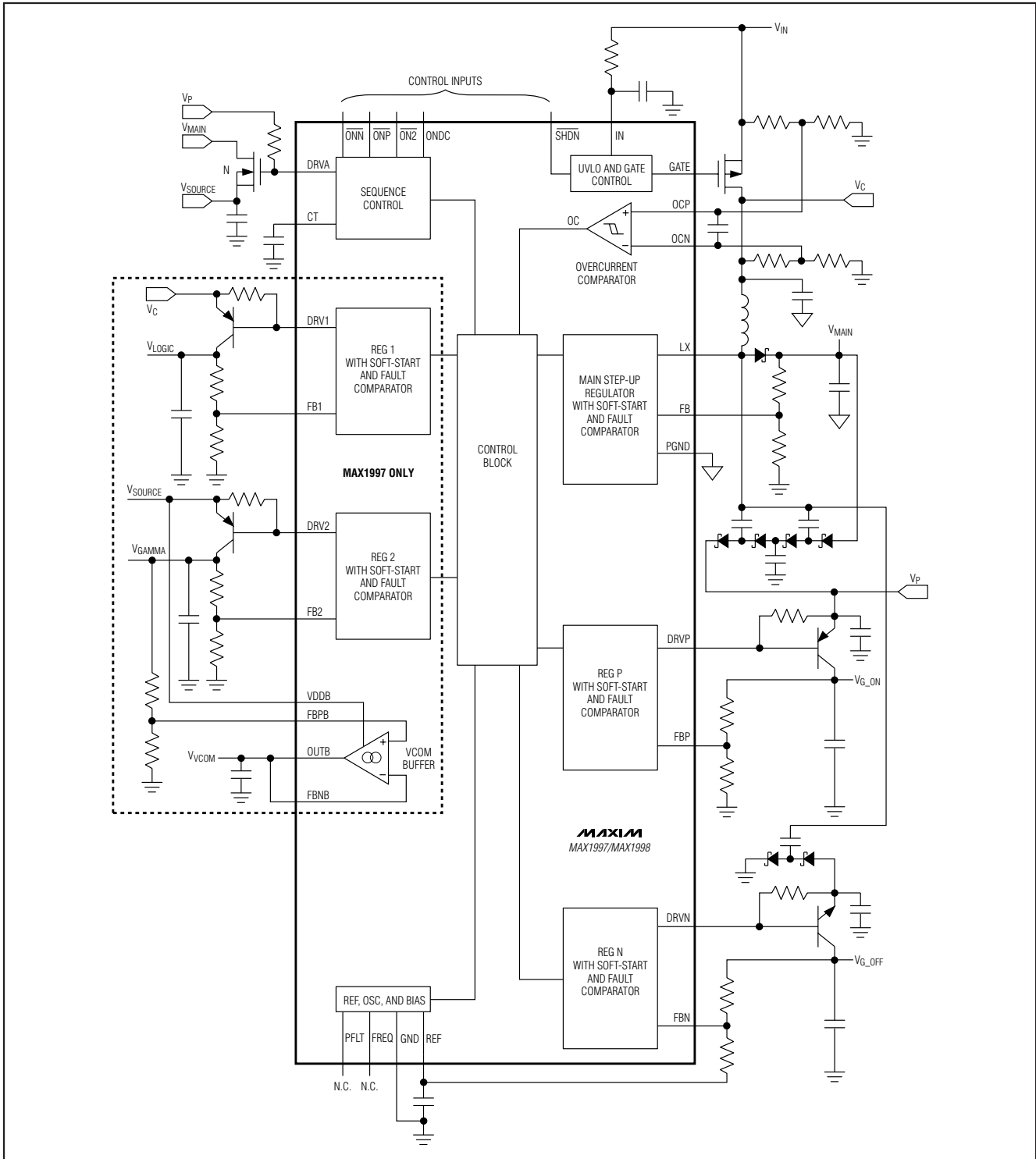

Figure 2. System Functional Diagram

Quintuple/Triple-Output TFT LCD Power Supplies with Fault Protection and VCOM Buffer

MAX1997/MAX1998

Table 1. Selected Component List

DESIGNATION	DESCRIPTION
C2, C13	10 μ F, 6.3V X5R ceramic capacitors (1206), TDK C3216X5R0J106M
C4, C5, C6	4.7 μ F, 10V X7R ceramic capacitors (1210), Taiyo Yuden LMK352BJ475MF
D1	1.0A, 30V Schottky diode (S-flat), Toshiba CRS02
D2, D3, D4	200mA, 25V dual-series Schottky diodes (SOT23), Fairchild BAT54S
D5, D6	200mA, 75V diode (SOT23), Fairchild MMBD4148
L1	3.0 μ H, 1.3A inductor, Sumida CLS5D11HP-3R0NC
N1	1.9A, 30V N-channel MOSFET (SuperSOT™-3), Fairchild FDN357P
P1	2.4A, 20V P-channel MOSFET (SuperSOT-3), Fairchild FDN304P
Q1	3A, 25V PNP bipolar transistor (SuperSOT-3), Fairchild FSB749
Q2, Q3	200mA, 40V PNP bipolar transistors (SOT23), Fairchild MMBT3906
Q4	200mA, 40V NPN bipolar transistor (SOT23), Fairchild MMBT3904

SuperSOT is a trademark of Fairchild Semiconductor.

Table 2. Component Suppliers

SUPPLIER	PHONE	FAX	WEBSITE
Fairchild	408-822-2000	408-822-2102	www.fairchildsemi.com
Sumida	847-545-6700	847-545-6720	www.sumida.com
Taiyo Yuden	800-348-2496	847-925-0899	www.t-yuden.com
TDK	847-803-6100	847-390-4405	www.component.tdk.com
Toshiba	949-455-2000	949-859-3963	www.toshiba.com

Standard Application Circuit

The standard application circuit (Figure 1) of the MAX1997 is a complete power-supply system for TFT liquid-crystal displays. The circuit generates 9V for source drivers, +20V and -7V for gate drivers, a 2.5V logic supply for the timing controller, a 8.6V gamma reference voltage, and a VCOM buffer. The input voltage range is from 2.7V to 5.5V. Table 1 lists the selected component options and Table 2 lists the component suppliers.

Detailed Description

The MAX1997 and MAX1998 contain a high-performance step-up switching regulator, two low-cost linear-regulator controllers, and multiple levels of protection circuitry. The MAX1997 also includes two additional linear-regulator controllers and a high-current VCOM buffer. Figure 2 shows the MAX1997/MAX1998 system functional diagram. The output voltage of the main step-up regulator (V_{MAIN}) can be set from V_{IN} to 13V with an external resistive voltage-divider. High switching frequency (375kHz/750kHz/1.5MHz) and current-mode control provide fast transient response and allow the use of low-profile inductors and ceramic capacitors.

The low $R_{DS(ON)}$ internal power MOSFET minimizes the external component count and achieves high efficiency using a lossless current-sense architecture.

Two charge pumps take energy from the main step-up regulator's switching node (LX) to generate positive and negative supplies. Additional capacitor and diode stages can be used to generate supply voltages greater than +35V and less than -15V. The positive and negative linear-regulator controllers postregulate the charge-pump supply voltages and allow users to program the power-up sequence as well.

The high-current VCOM buffer of the MAX1997 is ideal for driving the backplane of a TFT LCD panel. It requires only a 0.47 μ F ceramic output capacitor for stability. The MAX1997's two additional linear-regulator controllers can be used to build the gamma reference and logic supply.

The unique input switch control of the MAX1997/MAX1998 senses the current drawn from the input power supply by monitoring the voltage drop across the input P-channel MOSFET. The protection MOSFET and all regulator outputs latch off if an overcurrent condition lasts for more than the fault timer period.

Quintuple/Triple-Output TFT LCD Power Supplies with Fault Protection and VCOM Buffer

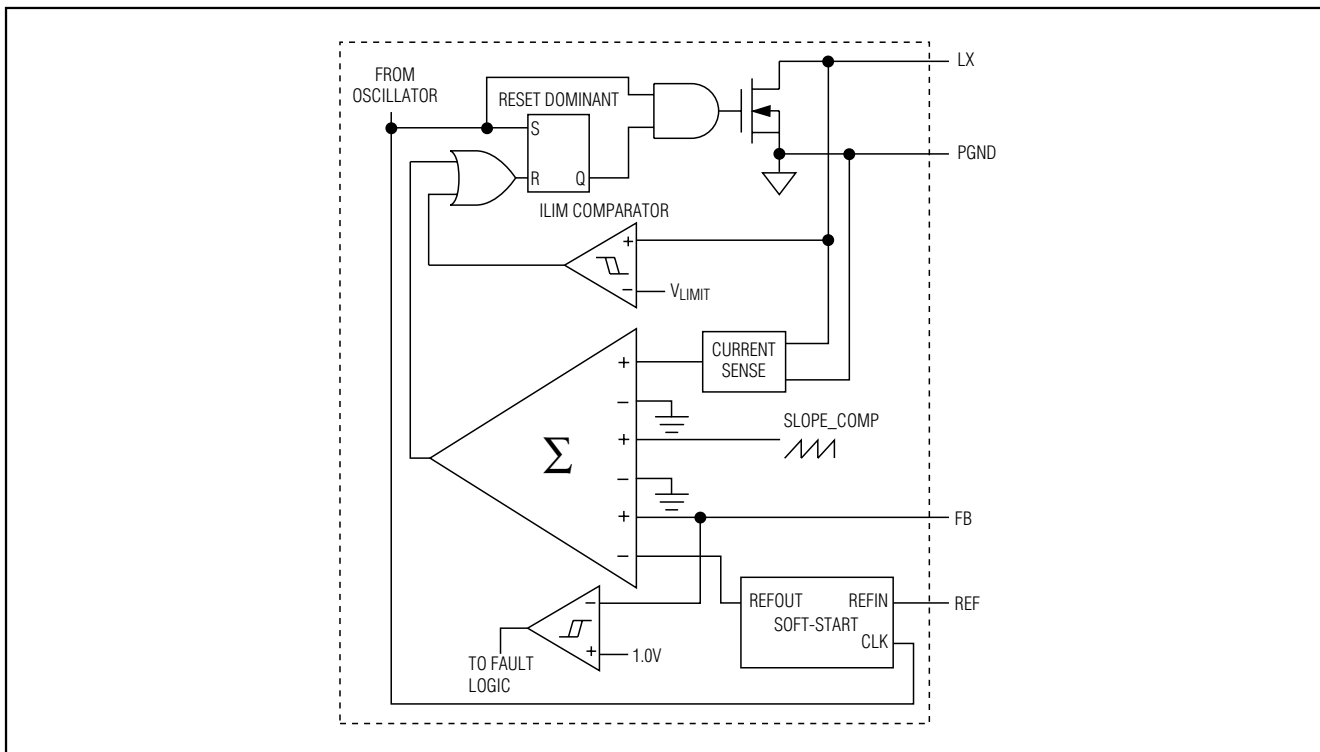

Figure 3. Main Step-Up Converter Functional Diagram

In addition, all outputs are monitored for fault conditions that last longer than the fault timer period. The device goes into a latched shutdown state, if the junction temperature of the device exceeds +160°C.

Main Step-Up Controller

The main step-up regulator switches at up to 1.5MHz, and employs a current-mode control architecture to maximize loop bandwidth and provide fast transient response to pulsed loads found in source drivers for TFT LCD panels. In addition, the high switching frequency allows the use of low-profile inductors and ceramic capacitors to minimize the thickness of LCD panel designs. The integrated high-efficiency MOSFET reduces the number of external components. The IC's built-in soft-start function controls the inrush current.

Depending on the input-to-output voltage ratio, the regulator controls the output voltage and the power delivered to the output by modulating the duty cycle (D) of the power MOSFET in each switching cycle.

The duty cycle of the MOSFET is approximated by:

$$D \approx \frac{V_{\text{MAIN}} - V_{\text{IN}}}{V_{\text{MAIN}}}$$

On the rising edge of the internal clock, the controller sets a flip-flop, which turns on the N-channel MOSFET (Figure 3). The input voltage is applied across the inductor. The inductor current ramps up linearly, storing energy in a magnetic field. Once the sum of the feedback voltage, slope-compensation, and current-feedback signals trip the multi-input PWM comparator, the MOSFET turns off, and the flip-flop resets. Since the inductor current is continuous, a transverse potential develops across the inductor that turns on the diode (D1). The voltage across the inductor becomes the difference between the output voltage and the input voltage. This discharge condition forces the current through the inductor to ramp back down, transferring the energy stored in the magnetic field to the output capacitor and the load. The MOSFET remains off for the rest of the clock cycle.

Quintuple/Triple-Output TFT LCD Power Supplies with Fault Protection and VCOM Buffer

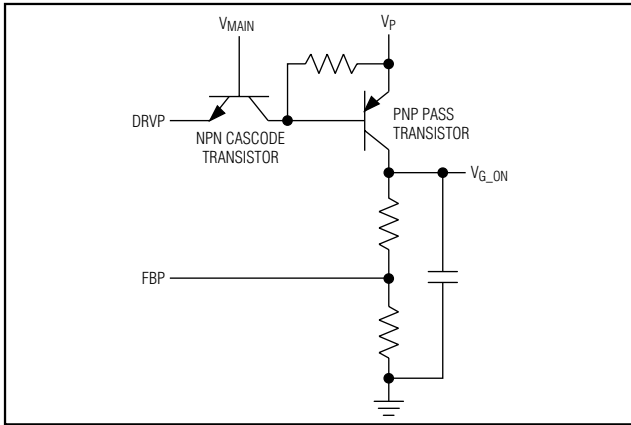

Figure 4. Using Cascode NPN for Output Voltages > 28V

Positive Linear-Regulator Controller, REG P

The positive linear-regulator controller is an analog gain block with an open-drain N-channel output. It drives an external PNP pass transistor with a 6.8kΩ base-to-emitter resistor (Figure 1). Its guaranteed base drive sink current is at least 2mA. The regulator is designed to deliver 20mA with an output capacitor of 1μF.

REG P is enabled when $\overline{\text{SHDN}}$ is high, the gate to the input P-channel MOSFET is low, ONDC is high, $V_{CT} > V_{ONP}$, and the soft-start of the main step-up regulator is complete. (See the *Power-Up Sequencing and Inrush Current Control* section.) Each time it is enabled, the regulator goes through a soft-start routine that ramps up its reference input.

Note that the voltage rating of the DRVP output is 28V. If higher voltages are present, an external cascode NPN transistor should be used with the emitter connected to DRVP, the base to V_{MAIN} , and the collector to the base of the PNP (Figure 4).

REG P is typically used to provide the TFT LCD gate driver's gate-on voltage. A sufficient voltage can be produced using a charge-pump circuit as shown in Figure 1. Use as many stages as necessary to obtain the required output voltage. (See the *Selecting the Number of Charge-Pump Stages* section.)

Negative Linear-Regulator Controller, REG N

The negative linear-regulator controller is an analog gain block with an open-drain P-channel output. It drives an external NPN pass transistor with a 6.8kΩ base-to-emitter resistor (Figure 1). Its guaranteed base drive source current is at least 2mA. The regulator is designed to deliver 20mA with an output capacitor of 0.47μF.

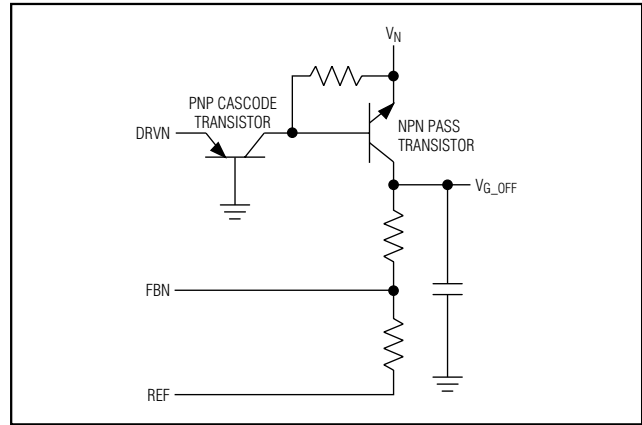

Figure 5. Using Cascode PNP for Output Voltages < $V_{\text{IN}} - 28\text{V}$

REG N is enabled when $\overline{\text{SHDN}}$ is high, the gate to the input P-channel MOSFET is low, ONDC is high, and $V_{CT} > V_{\text{ONN}}$ (see the *Power-Up Sequencing and Inrush Current Control* section). Each time it is enabled, the regulator goes through a soft-start routine that ramps down its reference input.

Note that the voltage rating of the DRVN output is $V_{\text{IN}} - 28\text{V}$. If lower voltages are present, an external cascode PNP transistor should be used with the emitter connected to DRVN, the base to GND, and the collector to the base of the NPN (Figure 5).

REG N is typically used to provide the TFT LCD gate driver's gate-off voltage. A negative voltage can be produced using a charge-pump circuit as shown in Figure 1. Use as many stages as necessary to obtain the required output voltage. (See the *Selecting the Number of Charge-Pump Stages* section.)

Linear-Regulator Controller, REG 1 (MAX1997 Only)

The linear-regulator controller REG 1 is an analog gain block with an open-drain N-channel output. It drives an external PNP pass transistor with a 510Ω base-to-emitter resistor (Figure 1). Its guaranteed base-drive sink current is at least 5mA. The regulator is designed to deliver 300mA with an output capacitor of 10μF.

REG 1 is enabled when $\overline{\text{SHDN}}$ is high and the gate to the input P-channel MOSFET is low. (See the *Power-Up Sequencing and Inrush Current Control* section.) Each time it is enabled, the regulator goes through a soft-start routine that ramps up its reference input. REG 1 is typically used to provide the TFT LCD timing controller's logic supply.

Quintuple/Triple-Output TFT LCD Power Supplies with Fault Protection and VCOM Buffer

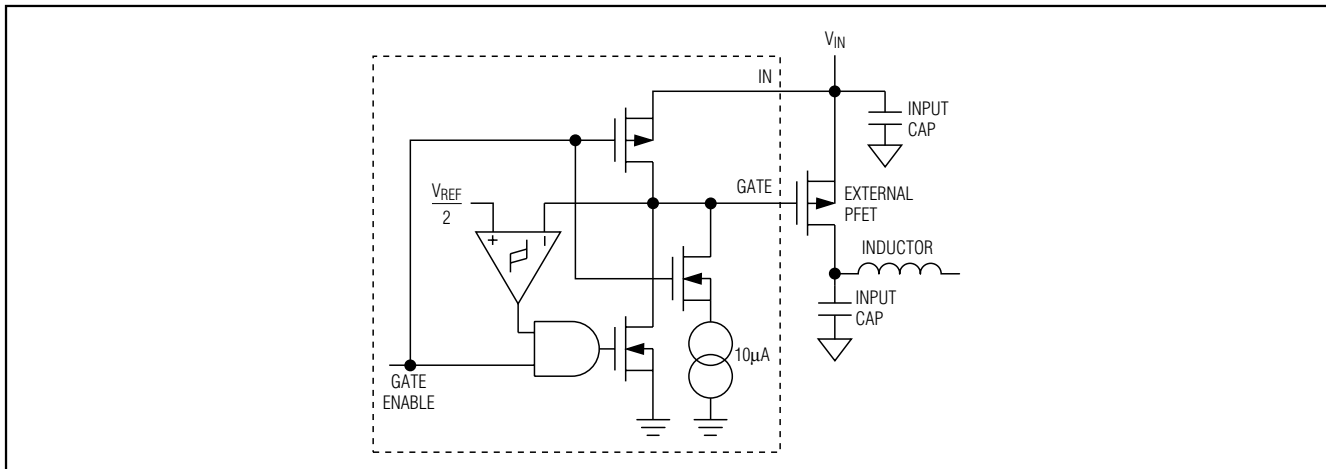

Figure 6. External P-Channel MOSFET Input Switch Control

Linear-Regulator Controller REG 2 (MAX1997 Only)

The linear-regulator controller REG 2 is an analog gain block with an open-drain N-channel output. It drives an external PNP pass transistor with a 2.2k Ω base-to-emitter resistor (Figure 1). Its guaranteed base drive sink current is at least 5mA. The regulator is designed to deliver 30mA with an output capacitor of 2.2 μ F.

REG 2 is enabled when $\overline{\text{SHDN}}$ is high, the gate to the input P-channel MOSFET is low, ONDC is high, and $V_{CT} > V_{ON2}$. (See the *Power-Up Sequencing and Inrush Current Control* section.) Each time it is enabled, the regulator goes through a soft-start routine that ramps up its reference input. REG 2 is typically used to provide the TFT LCD gamma reference voltage.

VCOM Buffer (MAX1997 Only)

The MAX1997 includes a VCOM buffer, which is an operational transconductance amplifier that provides a current output for driving the backplane of a TFT LCD panel. The unity-gain bandwidth of this current-output buffer is:

$$\text{GBW} = g_m / C_{\text{OUT}}$$

where g_m is the amplifier's transconductance, which is the ratio of the output current to the input voltage. The VCOM buffer requires only a 0.47 μ F ceramic output capacitor for stability. The bandwidth is inversely proportional to the output capacitance. Thus, large capacitive loads reduce the bandwidth of the buffer output.

In order to improve the transient response time, the amplifier has nonlinear transconductance. The amplifier senses the output current and increases the transconductance as the output current increases. The effect is to provide additional output current when the load demands it.

Undervoltage Lockout (UVLO)

To ensure that the input voltage is high enough for reliable operation, the MAX1997/MAX1998 include an undervoltage lockout (UVLO) circuit. The UVLO threshold at the IN pin is 2.7V (typ) rising and 2.35V (typ) falling. The 350mV (typ) hysteresis prevents supply transients from causing a restart. Once the input voltage exceeds the UVLO rising threshold, the controller enables the reference block. Once the reference is above 1.05V, an internal 10 μ A current source pulls the GATE pin low and turns on an external P-channel MOSFET switch (P1, Figure 1) that connects the input supply to the regulator. When the input voltage falls below the UVLO falling threshold, the controller turns off the reference and all the regulator outputs, and pulls GATE high with an internal 100 Ω switch to turn off P1 (Figure 6).

Reference Voltage (REF)

The reference output is nominally 1.25V, and can source up to 75 μ A. (See the *Typical Operating Characteristics*.) Bypass REF with a 0.22 μ F ceramic capacitor connected between REF and GND.

Oscillator Frequency Control (FREQ)

The internal oscillator frequency is adjustable using the three-level FREQ input. Connect FREQ to ground for 375kHz operation, connect FREQ to V_{IN} for 1.5MHz operation, and leave FREQ unconnected for 750kHz operation. When FREQ is left unconnected, bypass FREQ to ground with a 1000pF to 0.1 μ F capacitor to prevent switching noise from coupling into the pin's high input impedance. Note that the soft-start period scales with the oscillator frequency. (See the *Soft-Start* section.) The fault timer period does not scale with the oscillator frequency.

Quintuple/Triple-Output TFT LCD Power Supplies with Fault Protection and VCOM Buffer

Shutdown ($\overline{\text{SHDN}}$)

A logic-low signal on the $\overline{\text{SHDN}}$ pin disables all device functions including the reference. During shutdown, the supply current drops to 0.1 μA (typ) to maximize battery life. The output capacitance, feedback resistors, and load current determine the rate at which each output voltage decays. A logic-high signal on the $\overline{\text{SHDN}}$ pin activates the MAX1997/MAX1998. (See the *Power-Up Sequencing* section.) Do not leave the $\overline{\text{SHDN}}$ pin floating. Toggling $\overline{\text{SHDN}}$ (below 0.4V) or cycling IN (below 2.2V) clears the fault latch.

Power-Up Sequencing and Inrush Current Control

Once $\overline{\text{SHDN}}$ is pulled high and the input voltage on IN exceeds the rising input UVLO threshold (2.7V typ), the reference turns on. With a 0.22 μF REF bypass capacitor, the reference reaches its regulation voltage of 1.25V in approximately 1ms. When the reference voltage is ready, the MAX1997/MAX1998 enable the oscillator and fault detector. After the oscillator is enabled, the controller turns on the external P-channel MOSFET P1 (Figure 1) by pulling GATE low. The GATE is pulled down with a 10 μA current source. Add a capacitor from the gate of P1 to its drain to slow down the turn-on rate of the MOSFET, which reduces inrush current.

To guarantee slow turn-on at lower V_{IN} , add a series resistor between the GATE pin and the gate of the external P-channel MOSFET. The typical value of the resistor ranges between 100k Ω and 200k Ω . Once GATE reaches approximately 0.6V, an internal N-channel MOSFET turns on and pulls GATE to ground in order to maximize the enhancement of the external P-channel MOSFET. After P1 fully turns on, REG 1 and the fault counter are enabled.

A logic-high signal on ONDC enables the main step-up regulator and the sequence control block. The sequence control state diagram is shown in Figure 7. The unique sequence control block allows the positive gate-driver voltage ($V_{\text{G_ON}}$), negative gate-driver voltage ($V_{\text{G_OFF}}$), and the source-driver supply voltage (V_{SOURCE}) to be turned on in any order. The capacitor at the CT pin is kept discharged until the main step-up regulator is enabled. An internal 5 μA current source starts charging the CT capacitor and the CT voltage ramps linearly up to approximately V_{IN} . REG P, REG N, and REG 2 are enabled when the CT voltage exceeds their associated $\overline{\text{ON}}_x$ control inputs. In addition, the positive linear regulator waits for the completion of the main step-up regulator soft-start. The positive linear regulator is controlled by $\overline{\text{ONP}}$. The negative linear regulator is controlled by $\overline{\text{ONN}}$. REG2 and the open-drain output DRVA are controlled by $\overline{\text{ON2}}$. The DRVA signal can be used to turn on an external N-channel MOSFET

(N1, Figure 1), which connects the main step-up regulator output to the source driver's supply pins.

Soft-Start

Each positive regulator (MAIN, REG P, REG 1, and REG 2) includes a 5-bit soft-start DAC whose input is the reference, and whose output is stepped in 32 steps from zero up to the reference voltage. The soft-start DAC of the negative regulator (REG N) steps from the reference down to 125mV in 32 steps. The soft-start duration scales with the switching frequency selected and is 2.73ms for 1.5MHz operation, 5.46ms for 750kHz operation, and 10.92ms for 375kHz operation.

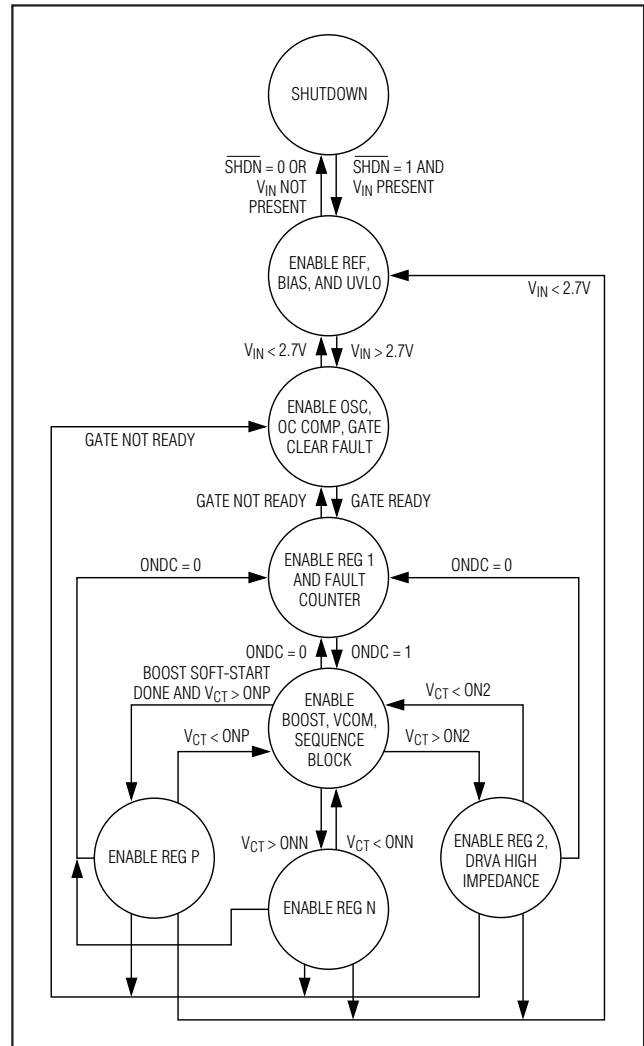

Figure 7. Power-Up Sequence State Diagram

Quintuple/Triple-Output TFT LCD Power Supplies with Fault Protection and VCOM Buffer

Table 3. Fault Timer Duration

FREQ PIN	PFLT PIN*	FAULT TIMER DURATION (CLOCK CYCLES)	FAULT TIMER DURATION (ms)
GND	GND	2 ¹³	21.8
Unconnected	GND	2 ¹⁴	21.8
IN	GND	2 ¹⁵	21.8
GND	Unconnected	2 ¹⁴	43.6
Unconnected	Unconnected	2 ¹⁵	43.6
IN	Unconnected	2 ¹⁶	43.6
GND	IN**	2 ¹⁵	87.2
Unconnected	IN**	2 ¹⁶	87.2
IN	IN**	2 ¹⁷	87.2

*For MAX1997 only.

**The MAX1998 has PFLT internally connected high.

Input Overcurrent Protection

The high-side overcurrent comparator of the MAX1997/MAX1998 provides input overcurrent protection when it is used together with the external P-channel MOSFET switch P1 (Figure 1). Connect resistive voltage-dividers from the source and drain of P1 to GND to set the overcurrent threshold. The center taps of the dividers are connected to the overcurrent comparator inputs (OCN and OCP). See *Setting the Input Overcurrent Threshold* section for information on calculating the resistor values. An overcurrent event activates the fault-protection circuitry. (See the *Fault Protection* section.)

Fault Protection

During steady-state operation, if the output of the main regulator or any of the linear-regulator outputs is below its respective fault detection threshold, or an input overcurrent condition occurs, the MAX1997/MAX1998 activate an internal fault timer (Figure 8). If any condition or the combination of conditions indicates a continuous fault for the fault timer duration (see Table 3), the MAX1997/MAX1998 set the fault latch, shutting down all the outputs except the reference and the oscillator. The fault detection circuit is disabled during the soft-start time of each regulator. Once the fault condition is removed, toggle SHDN (below 0.4V) or cycle the input voltage (below 2.2V) to clear the fault latch and reactivate the device.

Thermal Shutdown

The thermal shutdown feature limits total power dissipation in the MAX1997/MAX1998. If the junction temperature T_J exceeds +160°C, a thermal sensor immediately activates the fault protection (Figure 2) and sets the fault latch, which shuts down all the outputs except the reference, allowing the device to cool down. Once the

device cools down by at least 15°C, the fault latch can be cleared to reactivate the device. Toggling SHDN (below 0.4V) or cycling the input voltage (below 2.2V) clears the fault latch.

Design Procedure

Main Step-Up Regulator

Output Voltage Selection

Set the output voltage by connecting a resistive voltage-divider from the output (V_{MAIN}) to GND with the center tap connected to FB (see Figure 1). Select R8 to be 1.5k Ω or less for optimized transient response. For higher efficiency, increase R8 to 12k Ω and add lag compensation. (See the *Feedback Compensation* section.) Calculate R7 with the following equation:

$$R7 = R8 [(V_{MAIN} / V_{FB}) - 1]$$

where $V_{FB} = 1.242V - (D \times 20mV)$ and

$$D \approx (V_{MAIN} - V_{IN}) / V_{MAIN}$$

For example, if $V_{IN} = 3V$ and $D \approx 0.66$, then $V_{FB} = 1.229V$.

Choosing 1.21k Ω for R8, R7 is 7.65k Ω . Use 7.68k Ω for R7. V_{MAIN} can range from V_{IN} to 13V.

Inductor Selection

The minimum inductance value, peak current rating, series resistance, and size are factors to consider when selecting the inductor. These factors influence the converter's efficiency, maximum output load capability, transient response time, and output voltage ripple. For a switching frequency of 1.5MHz, use values between 1.8 μH and 4.7 μH . For a switching frequency of 750kHz, use values between 3.3 μH and 8.2 μH . For a switching frequency of 375kHz, use values between 6.8 μH and 15 μH .

Quintuple/Triple-Output TFT LCD Power Supplies with Fault Protection and VCOM Buffer

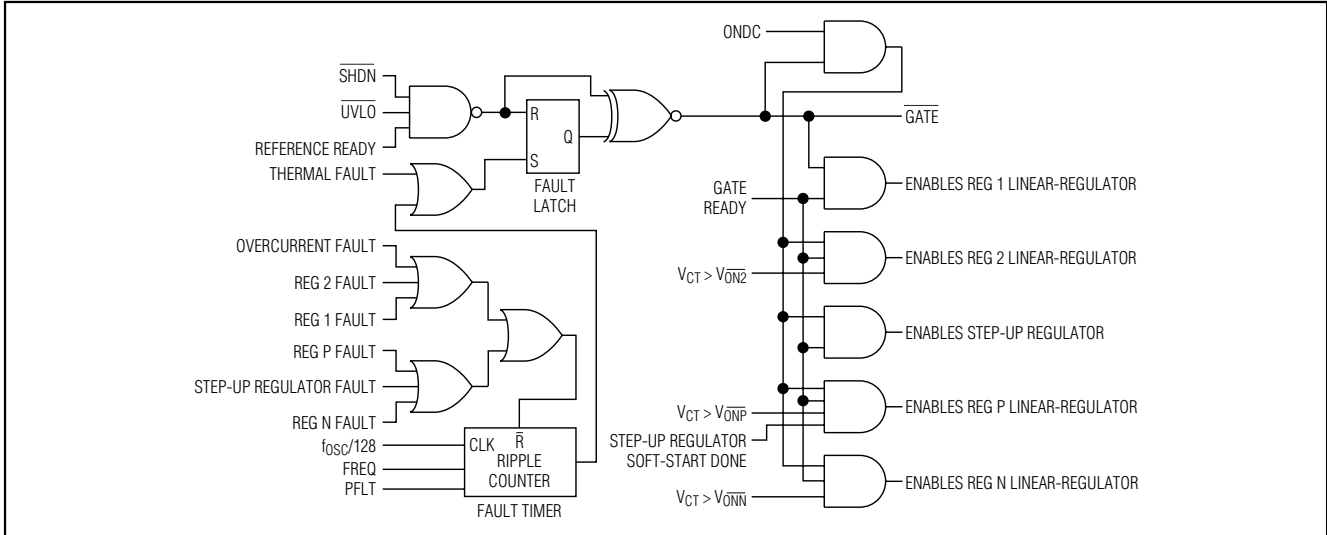

Figure 8. Startup and Fault Protection Logic

The maximum inductor current, input voltage, output voltage, and switching frequency determine the inductor value. To ensure an adequate inductor current-sense signal in the IC, always calculate the inductor value with the maximum guaranteed inductor current even though the actual operating current may be much lower. For the MAX1997/MAX1998, the maximum guaranteed inductor current is the minimum value of the internal LX current limit (1.6A, see the *Electrical Characteristics*). The equations provided here include a constant defined as LIR, which is the ratio of the peak-to-peak inductor current ripple to the average DC inductor current. For a good compromise between the size of the inductor, power loss, and output voltage ripple, select an LIR of 0.3 to 0.5. The inductance value is then given by:

$$L = \left(\frac{V_{IN(TYP)}}{V_{MAIN}} \right) \left(\frac{V_{MAIN} - V_{IN(TYP)}}{I_{L(MAX)} f_{OSC}} \right) \left(\frac{1}{LIR} \right)$$

where f_{OSC} is the oscillator frequency (see *Electrical Characteristics*), and $I_{L(MAX)}$ is 1.6A. Considering the typical application circuit, the typical input voltage is 3.3V, the main output voltage is 9V, and the switching frequency is 1.5MHz. Based on the above equations, the inductance value is 4.3 μ H for an LIR of 0.2. The inductance value is 1.7 μ H for an LIR of 0.5. The inductance in the standard application circuit is chosen to be 3.3 μ H.

The inductor's peak current rating should be higher than the expected peak inductor current throughout the normal operating range. The expected peak inductor current is given by:

$$I_{PEAK} = \left(\frac{I_{MAIN(MAX)} V_{MAIN}}{V_{IN(MIN)}} \right) \left(\frac{1}{\eta} \right) + \left(\frac{1}{2} \right) \left(\frac{V_{IN(MIN)}}{V_{MAIN}} \right) \left(\frac{V_{MAIN} - V_{IN(MIN)}}{L f_{OSC}} \right)$$

where η is the efficiency of the regulator. For most applications, the efficiency is between 75% and 85%.

Under fault conditions, the inductor current may reach the internal LX current limit (see *Electrical Characteristics*). However, soft saturation inductors and the controller's fast current-limit circuitry protect the device from failure during such a fault condition.

The inductor's DC resistance can significantly affect efficiency due to the resistive power loss (P_{LR}), which can be approximated by the following equation:

$$P_{LR} = I_{LAVG}^2 R_L \cong \left(\frac{I_{MAIN} \times V_{MAIN}}{V_{IN}} \right)^2 R_L$$

where I_{LAVG} is the average inductor current and R_L is the inductor's series resistance. For best performance, select inductors with resistance less than the internal N-channel MOSFET's on-resistance (0.25 Ω typ). To minimize radiated noise in sensitive applications, use a shielded inductor.

Quintuple/Triple-Output TFT LCD Power Supplies with Fault Protection and VCOM Buffer

Output Capacitor

The output capacitor affects the circuit's stability and output-voltage ripple. A 15µF ceramic capacitor works well in most 1.5MHz applications. Depending on the output capacitor chosen, feedback compensation may be required or desirable to increase the loop phase margin or increase the loop bandwidth for transient response. (See the *Feedback Compensation* section.)

The total output-voltage ripple has three components: the inductive ripple caused by the capacitor's equivalent series inductance (ESL), the ohmic ripple due to the capacitor's equivalent series resistance (ESR), and the capacitive ripple caused by the charging and discharging of the output capacitance. Since the ESL is usually very small, the inductive ripple can be neglected:

$$V_{RIPPLE} = V_{RIPPLE(ESR)} + V_{RIPPLE(C)}$$

$$V_{RIPPLE(ESR)} \approx I_{PEAK} R_{ESR(COUT)}, \text{ and}$$

$$V_{RIPPLE(C)} \approx \frac{I_{MAIN}}{C_{OUT}} \left(\frac{V_{MAIN} - V_{IN}}{V_{MAIN} f_{OSC}} \right)$$

where I_{PEAK} is the peak inductor current. (See the *Inductor Selection* section.) For ceramic capacitors, the output voltage ripple is typically dominated by $V_{RIPPLE(C)}$. The voltage rating and temperature characteristics of the output capacitor must also be considered.

Feedback Compensation

Feedback compensation is not needed for the excellent stability and fast transient response of Figure 1's circuit. However, lead or lag compensation can be useful to compensate for layout issues, or optimize the transient response for various output capacitor or inductor values.

The loop stability of a current-mode step-up regulator can be analyzed by using a small-signal model. In continuous conduction mode, the loop gain transfer function consists of a DC loop gain, a dominant pole, a right-half-plane (RHP) zero, and an ESR zero. In the case of ceramic output capacitors, the ESR zero is at very high frequency and can be ignored. For stable operation, place the dominant pole at a low enough frequency to ensure that the loop gain reaches unity well before the RHP zero, preferably below one-third of the RHP zero frequency f_{Z_RHP} .

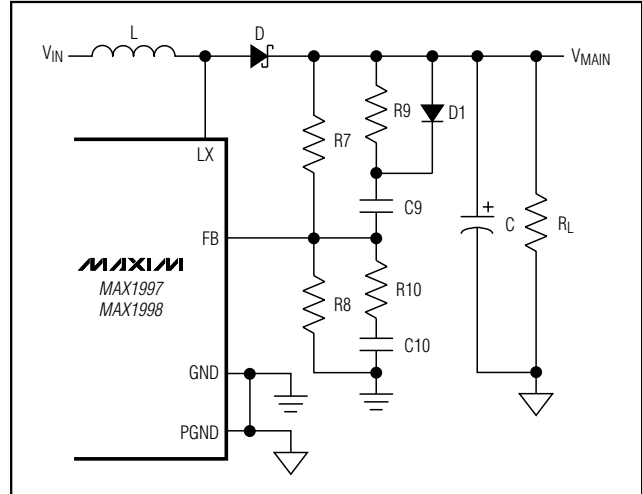

Figure 9. External Compensation

The frequency of the dominant pole is:

$$f_{P_DOMINANT} = \frac{1}{2\pi R_L C}$$

where R_L is the load resistance and C is the output capacitance; the frequency of the RHP zero is:

$$f_{Z_RHP} = (1 - D)^2 \frac{R_L}{2\pi L}$$

where D is the duty cycle and L is the inductance; and the DC gain is given by:

$$A_{DC} = 20 \times \log \left(\frac{R_8}{R_7 + R_8} \times \frac{(1-D)}{R_{CS}} \times R_L \right)$$

where R_{CS} is the 20mΩ internal equivalent current-sense resistor, and R_7 and R_8 are the feedback divider resistors in Figure 9.

Adding lead compensation (an RC network from V_{MAIN} to FB) increases the loop bandwidth, which can increase the speed of response to transients. Too much speed can destabilize the loop and is not needed or recommended for Figure 1's components.

Lead compensation adds a zero-pole pair, providing gain at higher frequencies and increasing loop bandwidth. The frequencies of the zero and pole for lead compensation depend on the feedback divider resistors and the RC network between V_{MAIN} and FB (Figure 9).

Quintuple/Triple-Output TFT LCD Power Supplies with Fault Protection and VCOM Buffer

The frequencies of the zero and pole for the lead compensation are:

$$f_{Z_LEAD} = \frac{1}{2\pi (R7 + R9) \times C9}$$

$$f_{P_LEAD} = \frac{1}{2\pi \left(R9 + \frac{R7 \times R8}{R7 \times R8} \right) \times C9}$$

At high frequencies, R9 is effectively in parallel with R7, determining the amount of added high-frequency gain. If R9 is very large, there is no added gain and as R9 approaches zero, the added gain approaches the inverse of the feedback divider's attenuation. A typical value for R9 is greater than half of R7. The value of C9 determines the frequency placement of the zero and pole. A typical value of C9 is between 100pF and 10nF. When adding lead compensation, always check the loop stability by monitoring the transient response to a pulsed output load.

Adding lag compensation (an RC network from FB to ground) decreases the loop bandwidth and improves FB noise immunity. Lag compensation slows the transient response but can increase stability margin, which can be needed for particular component choices, a poor layout, or high values of FB divider resistors (R8 greater than 1.5k Ω).

Lag compensation adds a pole-zero pair, attenuating gain at higher frequencies and lowering loop bandwidth. The frequencies of the pole and zero for lag compensation depend on the feedback divider resistors and the RC network between FB and GND (Figure 9).

The frequencies of the pole and zero for the lag compensation are:

$$f_{P_LAG} = \frac{1}{2\pi \left(R10 + \frac{R7 \times R8}{R7 + R8} \right) \times C10}$$

$$f_{Z_LAG} = \frac{1}{2\pi (R10 \times C10)}$$

At high frequencies, R10 is effectively in parallel with R8, increasing the divider attenuation ratio. If R10 is very large, the attenuation ratio remains unchanged and as R10 approaches zero, the attenuation ratio approaches infinity. A typical value for R10 is greater than 0.1 times R8. If high-value divider resistors are used, choose R10 < 1.5k Ω for FB noise immunity. The value of C10 determines the frequency placement of the pole and zero. A typical value of C10 is between 100pF and 1000pF.

When adding lag compensation, always check the loop stability by monitoring the transient response to a pulsed output load.

The circuit of Figure 1 works well without compensation. The circuit of Figure 9 uses lag compensation to allow higher value FB divider resistors, at the expense of transient response speed, potentially requiring higher value output capacitors (see *Typical Operating Characteristics*). Using one of these two circuits is recommended.

Using Compensation for Improved Soft-Start

The digital soft-start of the main step-up regulator limits the average input current during startup. If even smoother startup is needed, add a low-frequency lead compensation network (Figure 9). The improved soft-start is active only during startup when the output voltage rises. Positive changes in the output are instantaneously coupled to the FB pin through D1 and feed-forward capacitor C9. This arrangement generates a smoothly rising output voltage. When the output voltage reaches regulation, capacitor C9 charges up through R9 and diode D1 turns off. If desired, C9 and R9 can be chosen also to provide some lead compensation in normal operation. In most applications, lead compensation is not needed, and can be disabled by making R9 large. With R9 much greater than R7, the pole and the zero in the compensation network are very close to one another and cancel out after startup, eliminating the effect of the lead compensation.

Input Capacitor

The input capacitor (C_{IN}) reduces the current peaks drawn from the input supply and reduces noise injection into the device. A 10 μ F ceramic capacitor is used in the standard application circuit (Figure 1) because of the high source impedance seen in typical lab setups. Actual applications usually have much lower source impedance since the step-up regulator often runs directly from the output of another regulated supply. Typically, C_{IN} may be reduced below the values used in the standard applications circuit. Ensure a low-noise supply at the IN pin by using adequate C_{IN}. Alternatively, greater voltage variation can be tolerated on C_{IN} if IN is decoupled from C_{IN} using an RC lowpass filter (see R1, C1 in Figure 1).

Rectifier Diode

The MAX1997/MAX1998s' high switching frequency demands a high-speed rectifier. Schottky diodes are recommended for most applications because of their fast recovery time and low forward voltage. In general, a 1A Schottky diode complements the internal MOSFET well.

Quintuple/Triple-Output TFT LCD Power Supplies with Fault Protection and VCOM Buffer

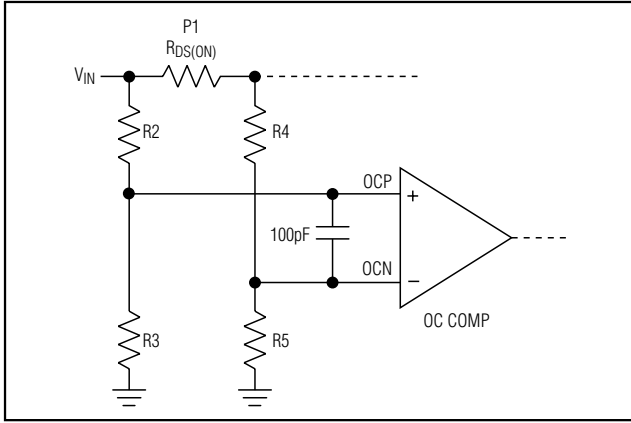

Figure 10. Setting the Overcurrent Threshold

Input P-Channel MOSFET

Select the input P-channel MOSFET based on current rating, voltage rating, gate threshold, and on-resistance. The MOSFET must be able to handle the peak input current (see the *Inductor Selection* section). The drain-to-source voltage rating of the input MOSFET should be higher than the maximum input voltage. Because the MOSFET conducts the full input current, its on-resistance should be low enough for good efficiency. Use a logic-level or low-threshold MOSFET to ensure that the switch is fully enhanced at the lowest input voltage.

Setting the Input Overcurrent Threshold

The high-side comparator of the MAX1997/MAX1998 provides input overcurrent protection when used in conjunction with an external P-channel MOSFET P1. The accuracy of the overcurrent threshold is affected by many factors, including comparator offset, resistor tolerance, input voltage range, and variations in MOSFET $R_{DS(ON)}$. The input overcurrent comparator is only intended to protect against catastrophic failures. This function is similar to an input fuse.

To minimize the impact of the comparator's input offset on the current-sense accuracy, the sense voltage should be close to the upper limit of the comparator's common-mode range (same as the operating range), which extends up to 80% of the input voltage. The resistive voltage divider R4/R5, combined with the on-state resistance of P1, sets the overcurrent threshold. The center of R4/R5 is connected to the inverting input (OCN) as shown in Figure 10.

If the comparator and resistors are ideal, the threshold is at the current where both inputs are equal:

$$V_{IN} \times \frac{R_3}{R_2 + R_3} = (V_{IN} - I_{L(MAX)} \times R_{DS(MAX)}) \times \frac{R_5}{R_4 + R_5}$$

$I_{L(MAX)}$ is the average inductor current at maximum load condition and minimum input voltage, and is given by:

$$I_{L(MAX)} = \frac{V_{OUT}}{\eta \times V_{IN(MIN)}} \times I_{LOAD(MAX)}$$

where η is the efficiency of the main step-up regulator.

If the step-up regulator's minimum input voltage is 2.7V, the output voltage is 9V, and the maximum load current is 0.3A. Assuming 80% efficiency, the maximum average inductor current is:

$$I_{L(MAX)} = \frac{9V}{0.8 \times 2.7V} \times 0.3A = 1.25A$$

$R_{DS(MAX)}$ is the maximum on-state drain-to-source resistance of P1. The maximum $R_{DS(ON)}$ at +25°C can be found in the MOSFET manufacturer's data sheet, but that number does not include the MOSFET's temperature coefficient. Since the resistance temperature coefficient is 0.5%/°C, $R_{DS(MAX)}$ can be calculated with the following equation:

$$R_{DS(MAX)} = R_{DS_{25C}} \times [1 + 0.005 \times (T_J - 25)]$$

where T_J is the actual MOSFET junction temperature in normal operation due to ambient temperature and self-heating caused by power dissipation. As an example, consider the Fairchild FDN304P, which has a maximum $R_{DS(ON)}$ at room temperature of 70mΩ. If the junction temperature is +100°C, the maximum on-state resistance over temperature is:

$$R_{DS(MAX)} = 70m\Omega [1 + 0.005 \times (100 - 25)] = 100m\Omega$$

For given R2 and R3 values, the ideal ratio of R4/R5 can be determined:

$$\frac{R_4}{R_5} = \frac{R_2 + R_3}{R_3} \times \frac{V_{IN} - I_{PEAK(MAX)} \times R_{DS(MAX)}}{V_{IN}} - 1$$

Quintuple/Triple-Output TFT LCD Power Supplies with Fault Protection and VCOM Buffer

After including the effects of resistor tolerance, comparator offset, and input voltage variation, the minimum input overcurrent threshold equation is:

$$V_{IN(MIN)} \times \frac{R3 \times (1+\epsilon)}{R2 \times (1+\epsilon) + R3 \times (1+\epsilon)} + 5mV = (V_{IN(MIN)} - I_{L(MAX)} \times R_{DS(MAX)}) \times \frac{R5 \times (1+\epsilon)}{R4 \times (1+\epsilon) + R5 \times (1+\epsilon)}$$

where $V_{IN(MIN)}$ is the minimum expected value of the input voltage, ϵ is the tolerance of the resistors, and 5mV is the worst-case input offset voltage of the comparator. To simplify the equation, define a constant (k) as follows:

$$k = \frac{1+\epsilon}{1-\epsilon}$$

The minimum threshold equation becomes:

$$V_{IN(MIN)} \times \frac{R3}{k \times R2 + R3} + 5mV = (V_{IN(MIN)} - I_{L(MAX)} \times R_{DS(MAX)}) \times \frac{k \times R5}{R4 + k \times R5}$$

Solving for $R4/R5$ yields:

$$\frac{R4}{R5} = k \times \left(\frac{V_{IN(MIN)} - I_{L(MAX)} \times R_{DS(MAX)}}{\frac{R3}{V_{IN(MIN)}} + 5mV} - 1 \right)$$

The $R4/R5$ ratio guarantees the required minimum level for $I_{L(MAX)}$. The typical overcurrent threshold is given by:

$$I_{TH_TYP} = \frac{V_{IN(TYP)}}{R_{DS(TYP)}} \times \left[1 - \frac{R3 \times (R4+R5)}{R5 \times (R2+R3)} \right]$$

The following example shows how to apply the above equations in the design. If 1% resistors are used, then $\epsilon = 0.01$. To set V_{OCP} to be around 75% of V_{IN} , select $R2 = 51.1k\Omega$ and $R3 = 150k\Omega$. Assume that the minimum input voltage is 2.7V and the typical input voltage is 3.3V, the average inductor current at maximum load is 1.25A, and the maximum $R_{DS(ON)}$ of P1 is 100m Ω :

$$k = \frac{1 - 0.01}{1 + 0.01} = 0.9802$$

$$\frac{R4}{R5} = 0.9802 \times \left(\frac{2.7V - 1.25A \times 0.1\Omega}{2.7V \times \frac{150\Omega}{150\Omega + 0.9802 \times 51.1k\Omega} + 0.005V} - 1 \right) = 0.2637$$

If $R5 = 150k\Omega$, then $R4 = 39.2k\Omega$. The typical overcurrent threshold is:

$$I_{TH_TYP} = \frac{3.3V}{0.047\Omega} \times \left[1 - \frac{150\Omega \times (39.2k\Omega + 150\Omega)}{150\Omega \times (51.1k\Omega + 150\Omega)} \right] = 4.15A$$

Charge Pumps

Selecting the Number of Charge-Pump Stages

For highest efficiency, always choose the lowest number of charge-pump stages that meet the output requirement. The number of positive charge-pump stages is given by:

$$N_{POS} = \frac{V_{G_ON} + V_{DROPOUT} - V_{MAIN}}{V_{MAIN} - 2 \times V_D}$$

where N_{POS} is the number of positive charge-pump stages, V_{G_ON} is the positive linear-regulator (REG P) output, V_{MAIN} is the main step-up regulator output, V_D is the forward voltage drop of the charge-pump diode, and $V_{DROPOUT}$ is the dropout margin for the linear regulator. Use $V_{DROPOUT} = 2V$.

The number of negative charge-pump stages is given by:

$$N_{NEG} = \frac{-V_{G_OFF} + V_{DROPOUT}}{V_{MAIN} - 2 \times V_D}$$

where N_{NEG} is the number of negative charge-pump stages, V_{G_OFF} is the negative linear-regulator (REG N) output, V_{MAIN} is the main step-up regulator output, V_D is the forward-voltage drop of the charge-pump diode, and $V_{DROPOUT}$ is the dropout margin for the linear regulator. Use $V_{DROPOUT} = 2V$.

The above equations are derived based on the assumption that the first stage of the positive charge pump is connected to V_{MAIN} and the first stage of the negative charge pump is connected to ground. Sometimes fractional stages are more desirable for better efficiency. This can be done by connecting the first stage to V_{IN} or another available supply. If the first charge-pump stage is powered from V_{IN} , then the above equations become:

$$N_{POS} = \frac{V_{G_ON} + V_{DROPOUT} - V_{IN}}{V_{MAIN} - 2 \times V_D}$$

$$N_{NEG} = \frac{-V_{G_OFF} + V_{DROPOUT} + V_{IN}}{V_{MAIN} - 2 \times V_D}$$

Quintuple/Triple-Output TFT LCD Power Supplies with Fault Protection and VCOM Buffer

Flying Capacitors

Increasing the flying capacitor (C_X) value increases the output current capability. Increasing the capacitance indefinitely has a negligible effect on output current capability because the internal switch resistance and the diode impedance limit the source impedance. A 0.1 μ F ceramic capacitor works well in most low-current applications. The flying capacitor's voltage rating must exceed the following:

$$V_{CX} > N \times V_{MAIN}$$

where N is the stage number in which the flying capacitor appears, and V_{MAIN} is the main output voltage. For example, the two-stage positive charge pump in the typical application circuit (Figure 1) where $V_{MAIN} = 9V$ contains two flying capacitors. The flying capacitor in the first stage (C_{25}) requires a voltage rating greater than 9V. The flying capacitor in the second stage (C_{24}) requires a voltage rating greater than 18V.

Charge-Pump Output Capacitor

Increasing the output capacitance or decreasing the ESR reduces the output ripple voltage and the peak-to-peak transient voltage. With ceramic capacitors, the output voltage ripple is dominated by the capacitance value. Use the following equation to approximate the required capacitor value:

$$C_{OUT} \geq \frac{I_{LOAD}}{2f_{OSC}V_{RIPPLE}}$$

where V_{RIPPLE} is the peak-to-peak value of the output ripple.

Charge-Pump Rectifier Diodes

Use Schottky diodes with a current rating equal to or greater than two times the average charge-pump input current. If the loaded charge-pump output voltage is greater than required, some or all of the Schottky diodes can be replaced with low-cost silicon switching diodes with an equivalent current rating. The charge-pump input current is:

$$I_{CP_IN} = I_{CP_OUT} \times N$$

where N is the number of charge-pump stages.

Linear-Regulator Controllers

Output Voltage Selection

Adjust the positive linear-regulator (REG P) output voltage by connecting a resistive voltage-divider from V_{G_ON} to GND with the center tap connected to FBP (Figure 1). Select R_{20} in the range of 10k Ω to 30k Ω .

Calculate R_{19} with the following equation:

$$R_{19} = R_{20} [(V_{G_ON} / V_{FBP}) - 1]$$

where $V_{FBP} = 1.25V$.

The output voltages of linear regulators REG 1 and REG 2 can be similarly adjusted.

Adjust the negative linear-regulator (REG N) output voltage by connecting a resistive voltage-divider from V_{G_OFF} to REF with the center tap connected to FBN (Figure 1). Select R_{17} in the range of 10k Ω to 30k Ω . Calculate R_{16} with the following equation:

$$R_{16} = R_{17} [(V_{FBN} - V_{G_OFF}) / (V_{REF} - V_{FBN})]$$

where $V_{FBN} = 125mV$, $V_{REF} = 1.25V$. REF can source up to 75 μ A, using a resistor greater than 17k Ω for R_{17} leaves at least 10 μ A for other uses.

Pass Transistor Selection

The pass transistor must meet specifications for current gain (β), input capacitance, collector-emitter saturation voltage, and power dissipation. The transistor's current gain limits the guaranteed maximum output current to:

$$I_{LOAD(MAX)} = \left(I_{DRV} - \frac{V_{BE}}{R_{BE}} \right) \beta_{MIN}$$

where I_{DRV} is the minimum guaranteed base drive current, V_{BE} is the base-to-emitter voltage of the transistor, and R_{BE} is the pullup resistor connected between the transistor's base and emitter. Furthermore, the transistor's current gain increases the linear regulator's DC loop gain (see the *Stability Requirements* section), so excessive gain destabilizes the output. Therefore, transistors with current gain over 100 at the maximum output current can be difficult to stabilize and are not recommended. The transistor's input capacitance and input resistance also create a second pole, which could be low enough to make the output unstable when heavily loaded.

The transistor's saturation voltage at the maximum output current determines the minimum input-to-output voltage differential that the linear regulator supports. Alternatively, the package's power dissipation could limit the usable maximum input-to-output voltage differential. The maximum power dissipation capability of the transistor's package and mounting must exceed the actual power dissipation in the device. The power dissipation equals the maximum load current times the maximum input-to-output voltage differential:

$$P = I_{LOAD(MAX)} (V_{LDOIN} - V_{LDOOUT}) = I_{LOAD(MAX)} V_{CE}$$

Quintuple/Triple-Output TFT LCD Power Supplies with Fault Protection and VCOM Buffer

Stability Requirements

The MAX1997/MAX1998 linear-regulator controllers use an internal transconductance amplifier to drive an external pass transistor. The transconductance amplifier, the pass transistor, the base-emitter resistor, and the output capacitor determine the loop stability.

The transconductance amplifier regulates the output voltage by controlling the pass transistor's base current. The total DC loop gain is approximately:

$$A_{V(LDO)} = \left(\frac{4}{V_T} \right) \left[1 + \left(\frac{I_{BIAS} h_{FE}}{I_{LOAD}} \right) \right] V_{REF}$$

where V_T is 26mV at room temperature, h_{FE} is the pass transistor's DC current gain, and I_{BIAS} is the current through the base-to-emitter resistor (R_{BE}). Each of the four linear-regulator controllers is designed for a different maximum output current so they have different output drive currents and different bias currents (I_{BIAS}). Each controller's bias current can be found in the *Electrical Characteristics*. The current listed in the Conditions column for the FB_ Regulation Voltage specification is the individual controller's bias current. The base-to-emitter resistor for each controller should be chosen to set the correct I_{BIAS} :

$$R_{BE} = \frac{V_{BE}}{I_{BIAS}}$$

The output capacitor and the load resistance create the dominant pole in the system. However, the internal amplifier delay, the pass transistor's input capacitance, and the stray capacitance at the feedback node create additional poles in the system, and the output capacitor's ESR generates a zero. For proper operation, use the following steps to ensure the linear regulator stability:

- 1) First, calculate the dominant pole set by the linear regulator's output capacitor and the load resistor:

$$f_{POLE(LDO)} = \frac{1}{2\pi C_{LDO} R_{LOAD}}$$

where C_{LDO} is the output capacitance of the LDO and R_{LOAD} is the load resistance corresponding to the maximum load current.

The unity gain crossover of the linear regulator is:

$$f_{CROSSOVER} = A_{V(LDO)} f_{POLE(LDO)}$$

- 2) The pole caused by the internal amplifier delay is at about 1MHz:

$$f_{POLE(AMP)} \cong 1\text{MHz}$$

- 3) Next, calculate the pole set by the transistor's input capacitance, the transistor's input resistance, and the base-to-emitter pullup resistor:

$$f_{POLE(CIN)} = \frac{1}{2\pi C_{IN}(R_{BE} \parallel R_{IN})}$$

Because R_{BE} is much greater than R_{IN} , the above equation can be simplified:

$$f_{POLE(CIN)} \approx \frac{1}{2\pi C_{IN} R_{IN}}$$

$$C_{IN} = \frac{g_m}{2\pi f_T}$$

$$R_{IN} = R_{\pi} = \frac{h_{FE}}{g_m}$$

where g_m is the transconductance of the pass transistor, and f_T is the transition frequency. Both parameters can be found in the transistor's data sheet. Therefore, the equation can be further simplified:

$$f_{POLE(CIN)} = \frac{f_T}{h_{FE}}$$

- 4) Next, calculate the pole set by the linear regulator's feedback resistance and the capacitance between FB_ and GND (approximately 5pF including stray capacitance):

$$f_{POLE(FB)_P} = \frac{1}{2\pi C_{FB}(R_{19} \parallel R_{20})}$$

$$f_{POLE(FB)_1} = \frac{1}{2\pi C_{FB}(R_{88} \parallel R_{99})}$$

$$f_{POLE(FB)_2} = \frac{1}{2\pi C_{FB}(R_{11} \parallel R_{12})}$$

and

$$f_{POLE(FB)_N} = \frac{1}{2\pi C_{FB}(R_{16} \parallel R_{17})}$$

- 5) Next, calculate the zero caused by the output capacitor's ESR:

$$f_{ESR_ZERO} = \frac{1}{2\pi C_{LDO} R_{ESR}}$$

where R_{ESR} is the equivalent series resistance of C_{LDO} .

Quintuple/Triple-Output TFT LCD Power Supplies with Fault Protection and VCOM Buffer

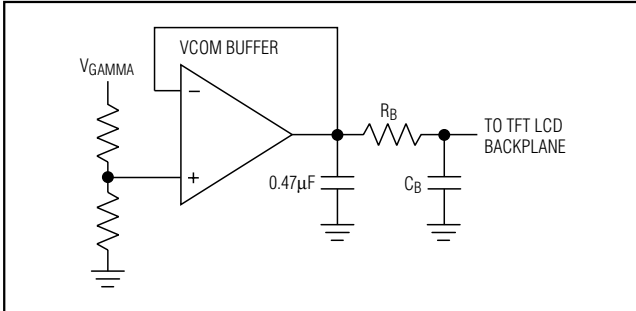

Figure 11. Optimizing VCOM Buffer Drive Current

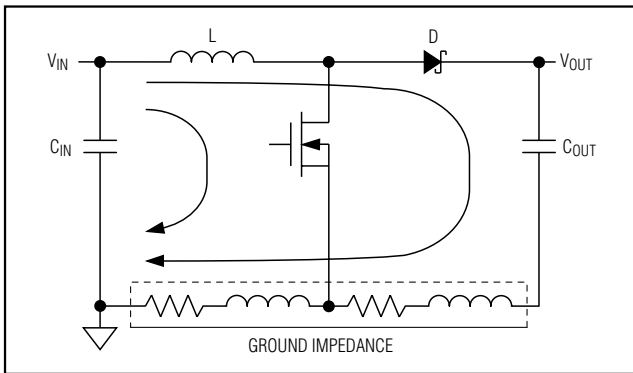

Figure 12. High-Current Loops of Step-Up Regulator

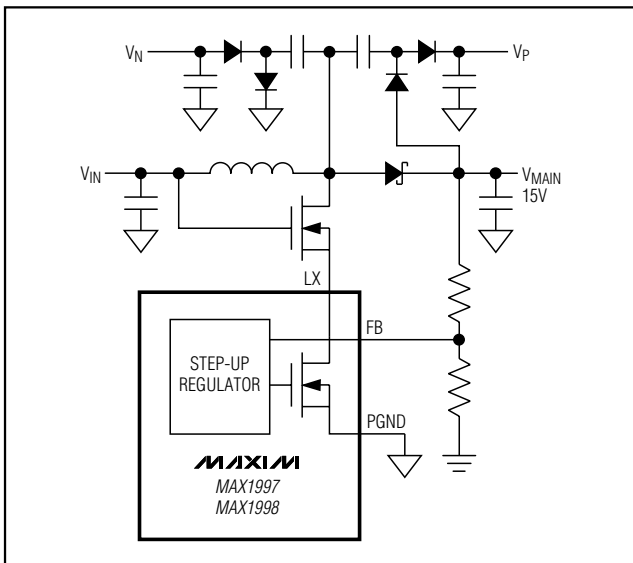

Figure 13. Operation with Output Voltage > 13V Using Cascoded MOSFET

6) To ensure stability, choose CLDO large enough so that the crossover occurs well before the poles and zero calculated in steps 2 to 5. The poles in steps 3 and 4 generally occur at several megahertz and using ceramic capacitors ensures the ESR zero occurs at several megahertz as well. Placing the crossover below 500kHz is sufficient to avoid the amplifier-delay pole and generally works well, unless unusual component choices or extra capacitances move the other poles or zero below 1MHz.

A capacitor connected between the regulator output and the feedback node can improve the transient response and reduce the noise coupled into the feedback loop (Figure 1).

If a low-dropout solution is needed, an external P-channel MOS pass transistor can be used for REG 1. However, a PMOS-based linear regulator requires higher output capacitance to stabilize the loop. The high gate capacitance of the P-channel MOSFET lowers $f_{POLE}(C_{IN})$ and can cause instability. A large output capacitor must be used to reduce the unity-gain bandwidth and ensure that the pole is well above the unity-gain crossover frequency. A ceramic capacitor of at least 30µF is recommended for $V_{IN} = 2.7V$, $V_{OUT} = 2.5V$, and $I_{LOAD} = 250mA$.

VCOM Buffer

Connect the inverting input FBINB directly to the output OUTB to configure the buffer as a voltage follower. Adjust the buffer's output voltage by connecting a voltage-divider from the gamma reference V_{GAMMA} to GND with the center tap connected to the noninverting input FBPB (Figure 1). Select R14 in the 10kΩ to 100kΩ range. Calculate R13 with the following equation:

$$R13 = R14 \left[\left(\frac{V_{GAMMA}}{V_{FBPB}} \right) - 1 \right]$$

The VCOM buffer is designed to be stable with a 0.47µF capacitor from OUTB to GND. The charge and discharge currents of the VCOM buffer output can be optimized by adding resistor R_B in series with the LCD backplane load and a ceramic capacitor C_B (1µF or larger) in parallel with the backplane load (Figure 11). Start with a 10Ω resistor, then gradually increase the value of R_B , balancing between display quality and buffer power dissipation. Increasing the value of C_B improves the efficiency of the VCOM buffer.

Quintuple/Triple-Output TFT LCD Power Supplies with Fault Protection and VCOM Buffer

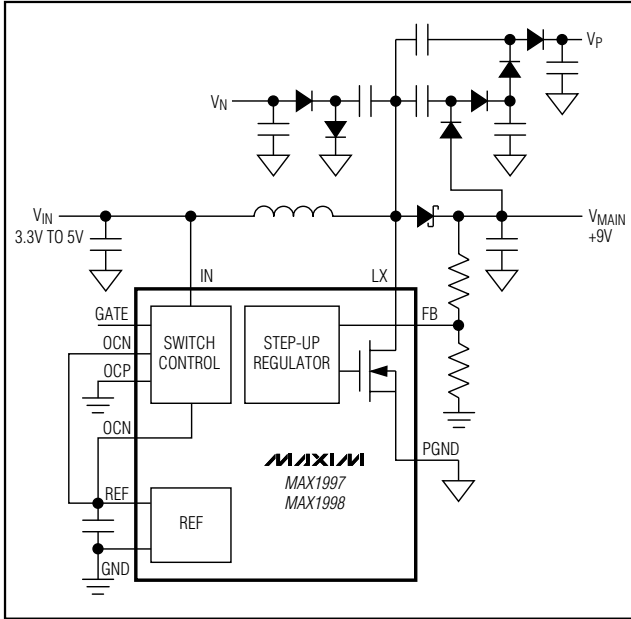

Figure 14. Disabling Input MOSFET Switch

Applications Information

PC Board Layout and Grounding

Careful PC board layout is extremely important for proper operation. Use the following guidelines for good PC board layout:

- 1) The high-current loops of the main step-up regulators are shown in Figure 12. Minimize the area of these loops by placing the input bypass capacitors, output diode, and output capacitors less than 0.2in (5mm) from the LX and PGND pins. Connect these components with traces as wide as possible. Avoid using vias in the high-current paths. If vias are unavoidable, use many vias in parallel to reduce resistance and inductance.
- 2) Create islands for the analog ground (GND), power ground (PGND), and linear-regulator ground. Connect all three ground areas (islands) at only one location, which is the backside pad of the device. The REF bypass capacitor and all feedback dividers should be connected to the analog ground island (GND). The step-up regulator's input and output capacitors, and the charge-pump components should be a wide power ground plane. The power ground plane should be connected to the power ground pin (PGND) with a wide trace. Maximizing

the width of the power ground traces improves efficiency and reduces output voltage ripple and noise spikes. All the other ground connections, such as the IN pin bypass capacitor and the linear-regulator output capacitors, should be star-connected to the backside of the device with wide traces. Make no other connections between these separate ground planes.

- 3) Place the IN pin and REF pin bypass capacitors as close to the device as possible.
- 4) Place all feedback voltage-divider resistors as close to their respective feedback pins as possible. The divider's center trace should be kept short. Placing the resistors far away causes their FB traces to become antennas that can pick up switching noise. Care should be taken to avoid running any feedback trace parallel to its associated drive trace or near LX or the switching nodes in the charge pumps.
- 5) Minimize the length and maximize the width of the traces between the output capacitors and the load for best transient responses.
- 6) Minimize the size of the LX node while keeping it wide and short. Keep the LX node away from feedback nodes (FB, FBP, and FBN) and analog ground. Use DC traces as a shield, if necessary. Large ground planes on a multilayer board can provide additional shielding.

Refer to the MAX1997 evaluation kit for an example of proper board layout.

Additional Application Circuits

Operation with Main Output Voltage >13V

The maximum output voltage of the step-up regulator is 13V, which is limited by the absolute maximum rating of the internal power MOSFET. To achieve higher output voltage, an external N-channel MOSFET can be cascaded with the internal FET (Figure 13). Since the gate of the external FET is biased from the input supply, use a logic-level FET to ensure that the FET is fully enhanced at the minimum input voltage. The current rating of the FET needs to be higher than the internal current limit.

Disabling Input MOSFET Switch

If the input protection MOSFET is not needed, disable the input overcurrent comparator by connecting the OCP pin to ground, and the OCN pin to REF. Leave the GATE pin floating (Figure 14).

Quintuple/Triple-Output TFT LCD Power Supplies with Fault Protection and VCOM Buffer

Pin Configurations (continued)

Chip Information

TRANSISTOR COUNT: 4704

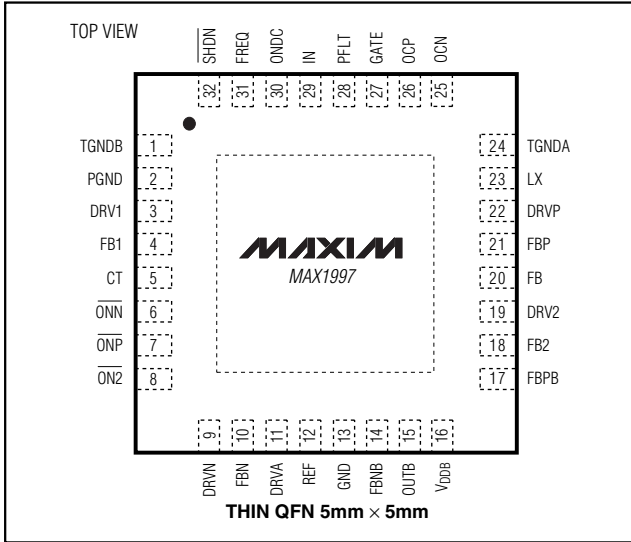

Quintuple/Triple-Output TFT LCD Power Supplies with Fault Protection and VCOM Buffer

Package Information

(The package drawing(s) in this data sheet may not reflect the most current specifications. For the latest package outline information, go to www.maxim-ic.com/packages.)

MAX1997/MAX1998

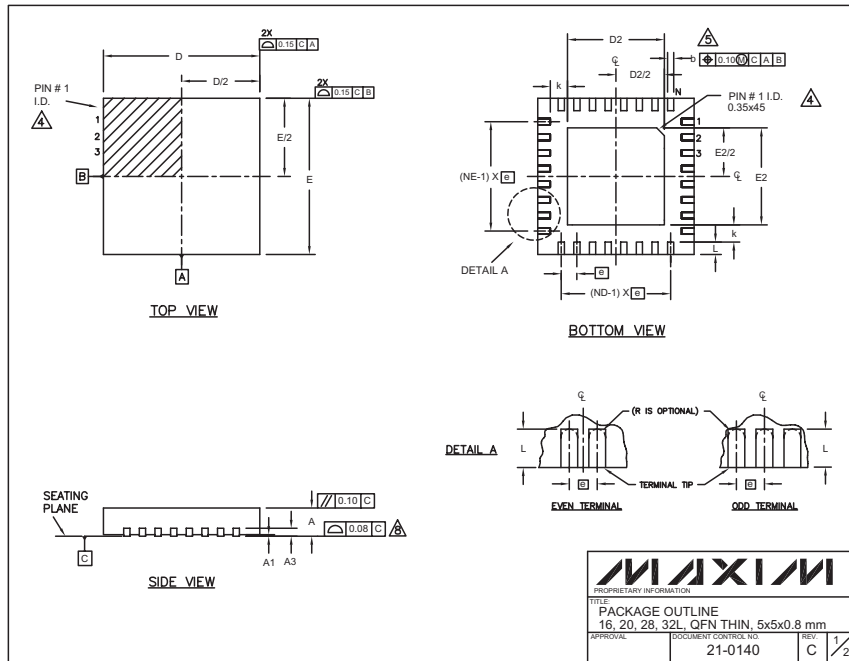

COMMON DIMENSIONS												
PKG. SYMBOL	16L 5x5			20L 5x5			28L 5x5			32L 5x5		
	MIN.	NOM.	MAX.	MIN.	NOM.	MAX.	MIN.	NOM.	MAX.	MIN.	NOM.	MAX.
A	0.70	0.75	0.80	0.70	0.75	0.80	0.70	0.75	0.80	0.70	0.75	0.80
A1	0	0.02	0.05	0	0.02	0.05	0	0.02	0.05	0	0.02	0.05
A3	0.20 REF.			0.20 REF.			0.20 REF.			0.20 REF.		
b	0.25	0.30	0.35	0.25	0.30	0.35	0.20	0.25	0.30	0.20	0.25	0.30
D	4.90	5.00	5.10	4.90	5.00	5.10	4.90	5.00	5.10	4.90	5.00	5.10
E	4.90	5.00	5.10	4.90	5.00	5.10	4.90	5.00	5.10	4.90	5.00	5.10
e	0.80 BSC.			0.65 BSC.			0.50 BSC.			0.50 BSC.		
k	0.25	-	-	0.25	-	-	0.25	-	-	0.25	-	-
L	0.45	0.55	0.65	0.45	0.55	0.65	0.45	0.55	0.65	0.30	0.40	0.50
N	16			20			28			32		
ND	4			5			7			8		
NE	4			5			7			8		
JEDEC	WHHB			WHHC			WHHD-1			WHHD-2		

EXPOSED PAD VARIATIONS						
PKG. CODES	D2			E2		
	MIN.	NOM.	MAX.	MIN.	NOM.	MAX.
T1655-1	3.00	3.10	3.20	3.00	3.10	3.20
T2055-2	3.00	3.10	3.20	3.00	3.10	3.20
T2855-1	3.15	3.25	3.35	3.15	3.25	3.35
T2855-2	2.60	2.70	2.80	2.60	2.70	2.80
T3255-2	3.00	3.10	3.20	3.00	3.10	3.20

NOTES:

- DIMENSIONING & TOLERANCING CONFORM TO ASME Y14.5M-1994.
- ALL DIMENSIONS ARE IN MILLIMETERS. ANGLES ARE IN DEGREES.
- N IS THE TOTAL NUMBER OF TERMINALS.
- THE TERMINAL #1 IDENTIFIER AND TERMINAL NUMBERING CONVENTION SHALL CONFORM TO JEDEC SPP-012. DETAILS OF TERMINAL #1 IDENTIFIER ARE OPTIONAL, BUT MUST BE LOCATED WITHIN THE ZONE INDICATED. THE TERMINAL #1 IDENTIFIER MAY BE EITHER A MOLD OR MARKED FEATURE.
- DIMENSION b APPLIES TO METALLIZED TERMINAL AND IS MEASURED BETWEEN 0.25 mm AND 0.30 mm FROM TERMINAL TIP.
- ND AND NE REFER TO THE NUMBER OF TERMINALS ON EACH D AND E SIDE RESPECTIVELY.
- DEPOPULATION IS POSSIBLE IN A SYMMETRICAL FASHION.
- COPLANARITY APPLIES TO THE EXPOSED HEAT SINK SLUG AS WELL AS THE TERMINALS.
- DRAWING CONFORMS TO JEDEC MO220.
- WARPAGE SHALL NOT EXCEED 0.10 mm.

MAXIM	
PROPRIETARY INFORMATION	
TITLE: PACKAGE OUTLINE 16, 20, 28, 32L, QFN THIN, 5x5x0.8 mm	
APPROVAL:	DOCUMENT CONTROL NO: 21-0140
REV:	C 2/2

Maxim cannot assume responsibility for use of any circuitry other than circuitry entirely embodied in a Maxim product. No circuit patent licenses are implied. Maxim reserves the right to change the circuitry and specifications without notice at any time.

Maxim Integrated Products, 120 San Gabriel Drive, Sunnyvale, CA 94086 408-737-7600 31

Looking for pricing, stock, or lifecycle information?

Click below to explore more details on WIN SOURCE:

 [View MAX1997ETJ+T on WIN SOURCE](#)

 [Maxim Integrated Information](#)

Optimize Your Supply Chain with WIN SOURCE Solutions

-  Global Sourcing Solution
-  Obsolete Management
-  Cost Control Management
-  Shortage Management
-  Alternative Solution
-  Excess Inventory Management