



# THE DATASHEET OF MAX3243EIDBR



# MAX3243E 3-V to 5.5-V Multichannel RS-232 Line Driver/Receiver

## With $\pm 15$ -kV IEC ESD Protection

### 1 Features

- Single-chip and single-supply interface for IBM™ PC/AT™ serial port
- ESD Protection for RS-232 bus pins
  - $\pm 15$ -kV Human-body model (HBM)
  - $\pm 8$ -kV IEC61000-4-2, contact discharge
  - $\pm 15$ -kV IEC61000-4-2, air-gap discharge
- Meets or exceeds requirements of TIA/EIA-232-F and ITU V.28 standards
- Operates with 3-V to 5.5-V  $V_{CC}$  supply
- Always-active noninverting receiver output (ROUT2B)
- Designed to transmit at a data rate up to 500 kbit/s
- Low standby current: 1  $\mu$ A typical
- External capacitors:  $4 \times 0.1 \mu$ F
- Accepts 5-V logic input with 3.3-V supply
- Designed to Be interchangeable with maxim MAX3243E
- Serial-Mouse Driveability
- Auto-powerdown feature to disable driver outputs when no valid RS-232 signal is sensed
- Package options include plastic small-outline (DW), shrink small-outline (DB), and thin shrink small-outline (PW) packages

### 2 Applications

- [Battery powered systems](#)
- [Wired Networking](#)
- [Data center and enterprise computing](#)
- [Battery-powered systems](#)
- [Notebooks](#)
- [Laptops](#)
- [Palmtop PCs](#)
- [Hand-held equipment](#)

### 3 Description

The MAX3243E device consists of three line drivers, five line receivers, and a dual charge-pump circuit with  $\pm 15$ -kV ESD (HBM and IEC61000-4-2, Air-Gap Discharge) and  $\pm 8$ -kV ESD (IEC61000-4-2, Contact Discharge) protection on serial-port connection pins. The device meets the requirements of TIA/EIA-232-F and provides the electrical interface between an asynchronous communication controller and the serial-port connector. This combination of drivers and receivers matches that needed for the typical serial port used in an IBM PC/AT, or compatible. The charge pump and four small external capacitors allow operation from a single 3-V to 5.5-V supply. In addition, the device includes an always-active noninverting output (ROUT2B), which allows applications using the ring indicator to transmit data while the device is powered down.

#### Package Information

PART NUMBER	PACKAGE <sup>(1)</sup>	BODY SIZE (NOM)
MAX3243E	SSOP (DB) (28)	10,20 mm $\times$ 5,30 mm
	SOIC (DW) (28)	17,90 mm $\times$ 7,50 mm
	TSSOP (PW) (28)	9,70 mm $\times$ 4,40 mm
	VQFN (RHB) (32)	5,00 mm $\times$ 5,00 mm

- (1) For all available packages, see the orderable addendum at the end of the data sheet.

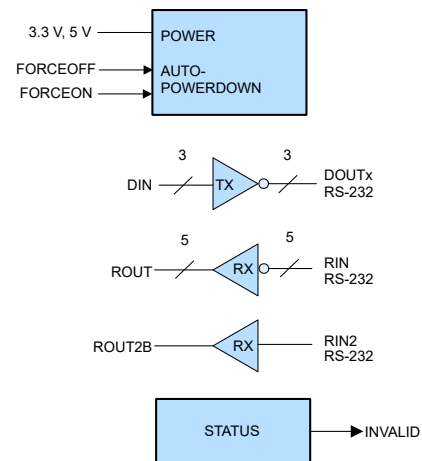

**Simplified Circuit**

## Table of Contents

<b>1 Features</b> .....	1	7.10 Driver Switching Characteristics.....	9
<b>2 Applications</b> .....	1	7.11 Receiver Switching Characteristics.....	9
<b>3 Description</b> .....	1	7.12 Auto-Powerdown Switching Characteristics.....	9
<b>4 Revision History</b> .....	2	<b>8 Parameter Measurement Information</b> .....	10
<b>5 Description (continued)</b> .....	2	<b>9 Detailed Description</b> .....	12
<b>6 Pin Configuration and Functions</b> .....	3	9.1 Overview.....	12
<b>7 Specifications</b> .....	6	9.2 Functional Block Diagram.....	12
7.1 Absolute Maximum Ratings.....	6	9.3 Feature Description.....	13
7.2 ESD Ratings.....	6	9.4 Device Functional Modes.....	13
7.3 ESD Ratings - IEC Specifications.....	6	<b>10 Application and Implementation</b> .....	14
7.4 Recommended Operating Conditions.....	6	10.1 Application Information.....	14
7.5 Thermal Information.....	7	10.2 Typical Application.....	14
7.6 Electrical Characteristics.....	7	10.3 Power Supply Recommendations.....	17
7.7 Driver Electrical Characteristics.....	8	10.4 Layout.....	17
7.8 Receiver, Electrical Characteristics.....	8	<b>11 Mechanical, Packaging, and Orderable Information</b> .....	18
7.9 Auto-Powerdown Electrical Characteristics.....	8		

## 4 Revision History

NOTE: Page numbers for previous revisions may differ from page numbers in the current version.

Changes from Revision D (September 2011) to Revision E (October 2022)	Page
• Added <i>Device Information table, ESD Ratings, ESD Ratings - IEC Specifications, Thermal Information, Detailed Description, Power Supply Recommendations, Layout, Device and Documentation Support Mechanical, Packaging, and Orderable Information</i> .....	1
• Deleted Ordering Information table.....	1
• Changed From: 250 kbit/s To: 500 kbit/s in the <i>Description</i> .....	1
• Changed the I <sub>CC</sub> Supply current auto-powerdown disabled MAX value from 1 mA to 1.2 mA in the <i>Electrical Characteristics</i> .....	7

Changes from Revision C (February 2009) to Revision D (September 2011)	Page
• Deleted "VALID RIN RS-232 LEVEL" from INPUTS.....	13
• Deleted "ROUT2B is active" RECEIVER STATUS and combined ROUT outputs.....	13
• Added table "Outputs ROUT2B and INVALID" defining truth for ROUT2B and INVALID outputs. ....	13

## 5 Description (continued)

The device operates at data signaling rates up to 250 kbit/s and a maximum of 30-V/ $\mu$ s driver output slew rate.

The MAX3243EC device is characterized for operation from 0°C to 70°C. The MAX3243EI device is characterized for operation from –40°C to 85°C.

## 6 Pin Configuration and Functions

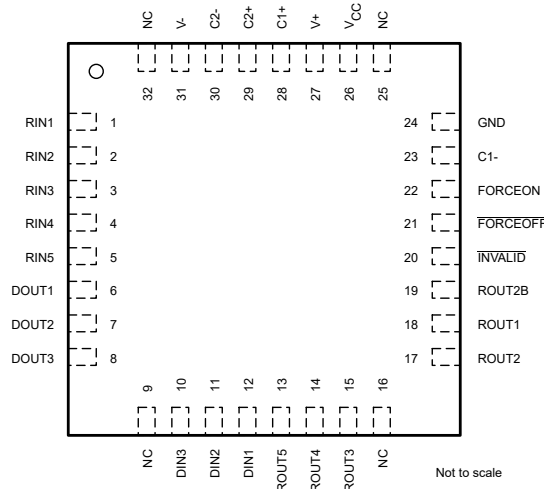

**Figure 6-1. RHB Package, 32 Pin (VQFN), Top View**

**Table 6-1. Pin Functions**

PIN		TYPE	DESCRIPTION
NO.	NAME		
1	RIN1	I	RS-232 receiver inputs
2	RIN2		
3	RIN3		
4	RIN4		
5	RIN5		
6	DOUT1	O	RS-232 driver outputs
7	DOUT2		
8	DOUT3		
9	NC	—	Not connected internally
10	DIN3	I	Driver inputs
11	DIN2		
12	DIN1		
13	ROUT5	O	Receiver outputs
14	ROUT4		
15	ROUT3		
16	NC	—	Not connected internally
17	ROUT2	O	Receiver outputs
18	ROUT1		
19	ROUT2B	O	Always-active noninverting receiver output
20	INVALID	O	Invalid Output Pin
21	FORCEOFF	I	Auto Powerdown Control input (Refer to Truth Table)
22	FORCEON	I	Auto Powerdown Control input (Refer to Truth Table)
23	C1-	—	Negative terminal of the voltage-doubler charge-pump capacitor
24	GND	—	Ground
25	NC	—	Not connected internally
26	V <sub>CC</sub>	—	3-V to 5.5-V supply voltage

**Table 6-1. Pin Functions (continued)**

PIN		TYPE	DESCRIPTION
NO.	NAME		
27	V+	—	Positive charge pump output voltage
28	C1+	—	Positive terminals of the voltage-doubler charge-pump capacitors
29	C2+	—	
30	C2-	—	Negative terminal of the voltage-doubler charge-pump capacitor
31	V-	—	Negative charge pump output voltage
32	NC	—	Not connected internally

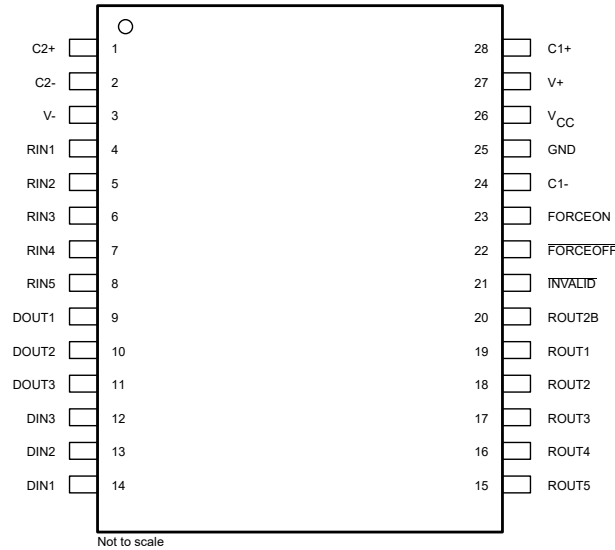

**Figure 6-2. DB, DW, or PW Package, 28 Pin (SSOP, SOIC, TSSOP), Top View**

**Table 6-2. Pin Functions**

PIN		TYPE	DESCRIPTION
NO.	NAME		
1	C2+	—	Positive terminal of the voltage-doubler charge-pump capacitor
2	C2-	—	Negative terminal of the voltage-doubler charge-pump capacitor
3	V-		Negative charge pump output voltage
4	RIN1	I	RS-232 receiver inputs
5	RIN2		
6	RIN3		
7	RIN4		
8	RIN5		
9	DOUT1	O	RS-232 driver outputs
10	DOUT2		
11	DOUT3		
12	DIN3	I	Driver inputs
13	DIN2		
14	DIN1		
15	ROUT5	O	Receiver outputs
16	ROUT4		
17	ROUT3		
18	ROUT2		
19	ROUT1		
20	ROUT2B	—	Always-active noninverting receiver output;
21	INVALID	O	Invalid Output Pin
22	FORCEOFF	I	Auto Powerdown Control input (Refer to Truth Table)
23	FORCEON	I	Auto Powerdown Control input (Refer to Truth Table)
24	C1-	—	Negative terminal of the voltage-doubler charge-pump capacitor
25	GND	—	Ground
26	V <sub>CC</sub>	—	3-V to 5.5-V supply voltage
27	V+	—	Positive charge pump output voltage
28	C1+	—	Positive terminal of the voltage-doubler charge-pump capacitor

## 7 Specifications

### 7.1 Absolute Maximum Ratings

over operating free-air temperature range (unless otherwise noted)<sup>(1)</sup>

		MIN	MAX	UNIT
V <sub>CC</sub>	Supply voltage range <sup>(2)</sup>	-0.3	6	V
V+	Positive output supply voltage range <sup>(2)</sup>	-0.3	7	V
V-	Negative output supply voltage range <sup>(2)</sup>	0.3	-7	V
V+ – V-	Output supply voltage difference <sup>(2)</sup>		13	V
V <sub>I</sub>	Input voltage range	Driver ( FORCEOFF, FORCEON)		V
		Receiver		
V <sub>O</sub>	Output voltage range	Driver		V
		Receiver ( INVALID)		
T <sub>stg</sub>	Storage temperature range	-65	150	°C

- (1) Stresses beyond those listed under *Absolute Maximum Ratings* may cause permanent damage to the device. These are stress ratings only, and functional operation of the device at these or any other conditions beyond those indicated under *Recommended Operating Conditions* is not implied. Exposure to absolute-maximum-rated conditions for extended periods may affect device reliability.
- (2) All voltages are with respect to network GND.

### 7.2 ESD Ratings

		VALUE	UNIT
V <sub>(ESD)</sub>	Electrostatic discharge	Human-body model (HBM), per ANSI/ESDA/JEDEC JS-001 DOUT1/2/3, RIN1/2/3/4/5 pins <sup>(1)</sup>	±15,000 V

- (1) JEDEC document JEP155 states that 500-V HBM allows safe manufacturing with a standard ESD control process.

### 7.3 ESD Ratings - IEC Specifications

		VALUE	UNIT
V <sub>(ESD)</sub>	Electrostatic discharge	IEC 61000-4-2 Contact Discharge <sup>(1)</sup>	RIN1, RIN2, RIN3, RIN4, RIN5, DOUT1, DOUT2 and DOUT3 pins
		IEC 61000-4-2 Air-gap Discharge <sup>(1)</sup>	
		±8,000	V
		±15,000	

- (1) For DB, PW and RHB package only: A minimum of 1-μF capacitor between V<sub>CC</sub> and GND is required to meet the specified IEC 61000-4-2 rating.

### 7.4 Recommended Operating Conditions

See [Figure 10-1](#) <sup>(1)</sup>

		MIN	NOM	MAX	UNIT
Supply voltage		V <sub>CC</sub> = 3.3 V	3	3.3	V
		V <sub>CC</sub> = 5 V	4.5	5	
V <sub>IH</sub>	Driver and control high-level input voltage	DIN, FORCEOFF, FORCEON		V	
		V <sub>CC</sub> = 3.3 V	2		
		V <sub>CC</sub> = 5 V	2.4		
V <sub>IL</sub>	Driver and control low-level input voltage	DIN, FORCEOFF, FORCEON		0.8	V
V <sub>I</sub>	Driver and control input voltage	DIN, FORCEOFF, FORCEON		0	5.5
V <sub>I</sub>	Receiver input voltage			-25	25
T <sub>A</sub>	Operating free-air temperature	MAX3243EC		0	70
		MAX3243EI		-40	85

- (1) Test conditions are C1–C4 = 0.1 μF at V<sub>CC</sub> = 3.3 V ± 0.3 V; C1 = 0.047 μF, C2–C4 = 0.33 μF at V<sub>CC</sub> = 5 V ± 0.5 V.

## 7.5 Thermal Information

THERMAL METRIC <sup>(1)</sup>		{DB} (SSOP)	{DW} (SOIC)	{PW} (TSSOP)	{RHB} (VQFN)	UNIT
		28 PINS	28 PINS	28 PINS	32 PINS	
R <sub>θJA</sub>	Junction-to-ambient thermal resistance	76.1	59.0	70.3	34.1	°C/W
R <sub>θJC(top)</sub>	Junction-to-case (top) thermal resistance	35.8	28.8	21.0	25.9	°C/W
R <sub>θJB</sub>	Junction-to-board thermal resistance	37.4	30.3	29.2	14.6	°C/W
ψ <sub>JT</sub>	Junction-to-top characterization parameter	7.4	7.8	1.3	0.5	°C/W
ψ <sub>JB</sub>	Junction-to-board characterization parameter	37.0	30.0	28.8	14.6	°C/W
R <sub>θJC(bot)</sub>	Junction-to-case (bottom) thermal resistance	N/A	N/A	N/A	5.1	°C/W

- (1) For more information about traditional and new thermal metrics, see the [Semiconductor and IC Package Thermal Metrics](#) application report.

## 7.6 Electrical Characteristics

over recommended ranges of supply voltage and operating free-air temperature (unless otherwise noted)<sup>(1)</sup> (see [Figure 10-1](#))

PARAMETER		TEST CONDITIONS	MIN	TYP <sup>(2)</sup>	MAX	UNIT
I <sub>I</sub>	Input leakage current	FORCEOFF, FORCEON		±0.01	±1	μA
I <sub>CC</sub>	Supply current (T <sub>A</sub> = 25°C)	Auto-powerdown disabled	No load, FORCEOFF and FORCEON at V <sub>CC</sub> For DB, PW and RHB package	0.3	1.2	mA
		Auto-powerdown disabled	No load, FORCEOFF and FORCEON at V <sub>CC</sub> For DW package	0.3	1	mA
		Powered off	No load, FORCEOFF at GND	1	10	μA
		Auto-powerdown enabled	No load, FORCEOFF at V <sub>CC</sub> , FORCEON at GND, All RIN are open or grounded, All DIN are grounded	1	10	

- (1) Test conditions are C1–C4 = 0.1 μF at V<sub>CC</sub> = 3.3 V ± 0.3 V; C1 = 0.047 μF, C2–C4 = 0.33 μF at V<sub>CC</sub> = 5 V ± 0.5 V.  
(2) All typical values are at V<sub>CC</sub> = 3.3 V or V<sub>CC</sub> = 5 V, and T<sub>A</sub> = 25°C.

## 7.7 Driver Electrical Characteristics

over recommended ranges of supply voltage and operating free-air temperature (unless otherwise noted)<sup>(1)</sup> (see Figure 10-1)

PARAMETER		TEST CONDITIONS	MIN	TYP <sup>(2)</sup>	MAX	UNIT
V <sub>OH</sub>	High-level output voltage	All DOUT at R <sub>L</sub> = 3 kΩ to GND	5	5.4		V
V <sub>OL</sub>	Low-level output voltage	All DOUT at R <sub>L</sub> = 3 kΩ to GND	-5	-5.4		V
V <sub>O</sub>	Output voltage (mouse driveability)	DIN1 = DIN2 = GND, DIN3 = V <sub>CC</sub> , 3-kΩ to GND at DOUT3, DOUT1 = DOUT2 = 2.5 mA	±5			V
I <sub>IH</sub>	High-level input current	V <sub>I</sub> = V <sub>CC</sub>		±0.01	±1	μA
I <sub>IL</sub>	Low-level input current	V <sub>I</sub> at GND		±0.01	±1	μA
V <sub>hys</sub>	Input hysteresis				±1	V
I <sub>OS</sub>	Short-circuit output current <sup>(3)</sup>	V <sub>CC</sub> = 3.6 V, V <sub>O</sub> = 0 V			±60	mA
		V <sub>CC</sub> = 5.5 V, V <sub>O</sub> = 0 V				
r <sub>o</sub>	Output resistance	V <sub>CC</sub> , V+, and V- = 0 V, V <sub>O</sub> = ±2 V	300	10M		Ω
I <sub>off</sub>	Output leakage current	FORCEOFF = GND, V <sub>O</sub> = ±12 V, V <sub>CC</sub> = 0 to 5.5 V			±25	μA

(1) Test conditions are C1–C4 = 0.1 μF at V<sub>CC</sub> = 3.3 V ± 0.3 V; C1 = 0.047 μF, C2–C4 = 0.33 μF at V<sub>CC</sub> = 5 V ± 0.5 V.

(2) All typical values are at V<sub>CC</sub> = 3.3 V or V<sub>CC</sub> = 5 V, and T<sub>A</sub> = 25°C.

(3) Short-circuit durations should be controlled to prevent exceeding the device absolute power dissipation ratings, and not more than one output should be shorted at a time.

## 7.8 Receiver, Electrical Characteristics

over recommended ranges of supply voltage and operating free-air temperature (unless otherwise noted)<sup>(1)</sup> (see Figure 10-1)

PARAMETER		TEST CONDITIONS	MIN	TYP <sup>(2)</sup>	MAX	UNIT
V <sub>OH</sub>	High-level output voltage	I <sub>OH</sub> = -1 mA	V <sub>CC</sub> - 0.6	V <sub>CC</sub> - 0.1		V
V <sub>OL</sub>	Low-level output voltage	I <sub>OH</sub> = 1.6 mA			0.4	V
V <sub>IT+</sub>	Positive-going input threshold voltage	V <sub>CC</sub> = 3.3 V		1.6	2.4	V
		V <sub>CC</sub> = 5 V		1.9	2.4	
V <sub>IT-</sub>	Negative-going input threshold voltage	V <sub>CC</sub> = 3.3 V	0.6	1.1		V
		V <sub>CC</sub> = 5 V	0.8	1.4		
V <sub>hys</sub>	Input hysteresis (V <sub>IT+</sub> - V <sub>IT-</sub> )			0.5		V
I <sub>off</sub>	Output leakage current (except ROUT2B)	FORCEOFF = 0 V		±0.05	±10	μA
r <sub>i</sub>	Input resistance	V <sub>I</sub> = ±3 V or ±25 V	3	5	7	kΩ

(1) Test conditions are C1–C4 = 0.1 μF at V<sub>CC</sub> = 3.3 V ± 0.3 V; C1 = 0.047 μF, C2–C4 = 0.33 μF at V<sub>CC</sub> = 5 V ± 0.5 V.

(2) All typical values are at V<sub>CC</sub> = 3.3 V or V<sub>CC</sub> = 5 V, and T<sub>A</sub> = 25°C.

## 7.9 Auto-Powerdown Electrical Characteristics

over recommended ranges of supply voltage and operating free-air temperature (unless otherwise noted) (see Figure 8-5)

PARAMETER		TEST CONDITIONS	MIN	MAX	UNIT
V <sub>IT+(valid)</sub>	Receiver input threshold for $\overline{\text{INVALID}}$ high-level output voltage	FORCEON = GND, FORCEOFF = V <sub>CC</sub>		2.7	V
V <sub>IT-(valid)</sub>	Receiver input threshold for $\overline{\text{INVALID}}$ high-level output voltage	FORCEON = GND, FORCEOFF = V <sub>CC</sub>	-2.7		V
V <sub>T(invalid)</sub>	Receiver input threshold for $\overline{\text{INVALID}}$ low-level output voltage	FORCEON = GND, FORCEOFF = V <sub>CC</sub>	-0.3	0.3	V
V <sub>OH</sub>	$\overline{\text{INVALID}}$ high-level output voltage	I <sub>OH</sub> = -1 mA, FORCEON = GND, FORCEOFF = V <sub>CC</sub>	V <sub>CC</sub> - 0.6		V
V <sub>OL</sub>	$\overline{\text{INVALID}}$ low-level output voltage	I <sub>OL</sub> = 1.6 mA, FORCEON = GND, FORCEOFF = V <sub>CC</sub>		0.4	V

## 7.10 Driver Switching Characteristics

switching characteristics over recommended ranges of supply voltage and operating free-air temperature (unless otherwise noted)<sup>(1)</sup> (see [Figure 10-1](#))

PARAMETER		TEST CONDITIONS	MIN	TYP <sup>(2)</sup>	MAX	UNIT	
	Maximum data rate	$C_L = 1000 \text{ pF}$ , One DOUT switching, $R_L = 3 \text{ k}\Omega$ See <a href="#">Figure 8-1</a>	250	500		kbit/s	
$t_{sk(p)}$	Pulse skew <sup>(3)</sup>	$C_L = 150 \text{ pF}$ to $2500 \text{ pF}$ , $R_L = 3 \text{ k}\Omega$ to $7 \text{ k}\Omega$ , See <a href="#">Figure 8-2</a>		100		ns	
$SR(tr)$	Slew rate, transition region (see <a href="#">Figure 8-1</a> )	$V_{CC} = 3.3 \text{ V}$ , $R_L = 3 \text{ k}\Omega$ to $7 \text{ k}\Omega$ , PRR = $250 \text{ kbit/s}$	$C_L = 150 \text{ pF}$ to $1000 \text{ pF}$		6	30	V/ $\mu\text{s}$
			$C_L = 150 \text{ pF}$ to $2500 \text{ pF}$		4	30	

- (1) Test conditions are  $C1-C4 = 0.1 \mu\text{F}$  at  $V_{CC} = 3.3 \text{ V} + 0.3 \text{ V}$ ;  $C1 = 0.047 \mu\text{F}$ ,  $C2-C4 = 0.33 \mu\text{F}$  at  $V_{CC} = 5 \text{ V} \pm 0.5 \text{ V}$ .  
(2) All typical values are at  $V_{CC} = 3.3 \text{ V}$  or  $V_{CC} = 5 \text{ V}$ , and  $T_A = 25^\circ\text{C}$ .  
(3) Pulse skew is defined as  $|t_{PLH} - t_{PHL}|$  of each channel of the same device.

## 7.11 Receiver Switching Characteristics

over recommended ranges of supply voltage and operating free-air temperature (unless otherwise noted)<sup>(1)</sup>

PARAMETER		TEST CONDITIONS	TYP <sup>(2)</sup>	UNIT
$t_{PLH}$	Propagation delay time, low- to high-level output	$C_L = 150 \text{ pF}$ , See <a href="#">Figure 8-3</a>	150	ns
$t_{PHL}$	Propagation delay time, high- to low-level output		150	ns
$t_{en}$	Output enable time	$C_L = 150 \text{ pF}$ , $R_L = 3 \text{ k}\Omega$ , See <a href="#">Figure 8-4</a>	200	ns
$t_{dis}$	Output disable time		200	ns
$t_{sk(p)}$	Pulse skew <sup>(3)</sup>	See <a href="#">Figure 8-3</a>	50	ns

- (1) Test conditions are  $C1-C4 = 0.1 \mu\text{F}$  at  $V_{CC} = 3.3 \text{ V} \pm 0.3 \text{ V}$ ;  $C1 = 0.047 \mu\text{F}$ ,  $C2-C4 = 0.33 \mu\text{F}$  at  $V_{CC} = 5 \text{ V} \pm 0.5 \text{ V}$ .  
(2) All typical values are at  $V_{CC} = 3.3 \text{ V}$  or  $V_{CC} = 5 \text{ V}$ , and  $T_A = 25^\circ\text{C}$ .  
(3) Pulse skew is defined as  $|t_{PLH} - t_{PHL}|$  of each channel of the same device.

## 7.12 Auto-Powerdown Switching Characteristics

over recommended ranges of supply voltage and operating free-air temperature (unless otherwise noted) (see [Figure 8-5](#))

PARAMETER		TEST CONDITIONS	TYP <sup>(1)</sup>	UNIT
$t_{valid}$	Propagation delay time, low- to high-level output	$V_{CC} = 5 \text{ V}$	1	$\mu\text{s}$
$t_{invalid}$	Propagation delay time, high- to low-level output	$V_{CC} = 5 \text{ V}$	30	$\mu\text{s}$
$t_{en}$	Supply enable time	$V_{CC} = 5 \text{ V}$	100	$\mu\text{s}$

- (1) All typical values are at  $V_{CC} = 3.3 \text{ V}$  or  $V_{CC} = 5 \text{ V}$ , and  $T_A = 25^\circ\text{C}$ .

## 8 Parameter Measurement Information

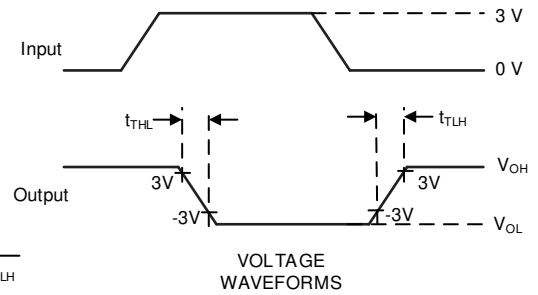
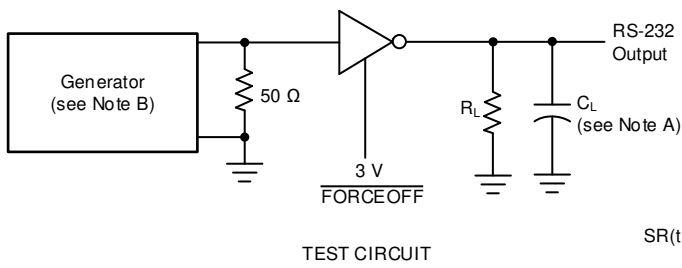

$$SR(tr) = \frac{6V}{t_{THL} \text{ or } t_{TLH}}$$

- A.  $C_L$  includes probe and jig capacitance
- B. The pulse generator has the following characteristics: PRR = 5 kbit/s,  $Z_O = 50 \Omega$ , 50 % duty cycle,  $t_r \leq 10 \text{ ns}$ ,  $t_f \leq 10 \text{ ns}$ .

**Figure 8-1. Driver Slew Rate**

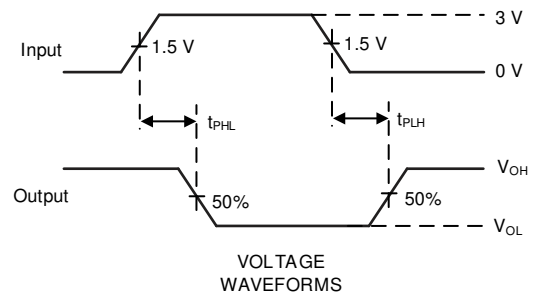
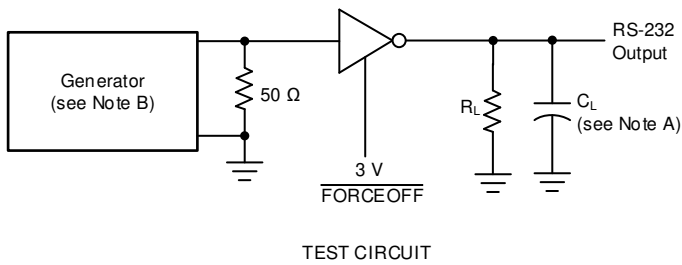

- A.  $C_L$  includes probe and jig capacitance
- B. The pulse generator has the following characteristics: PRR = 5 kbit/s,  $Z_O = 50 \Omega$ , 50 % duty cycle,  $t_r \leq 10 \text{ ns}$ ,  $t_f \leq 10 \text{ ns}$ .

**Figure 8-2. Driver Pulse Skew**

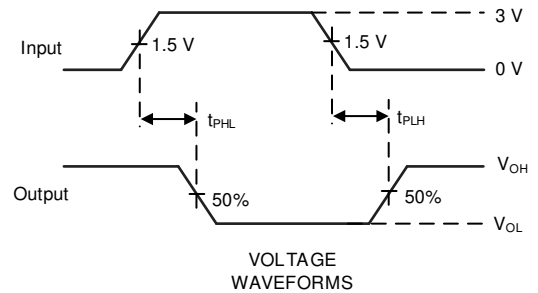
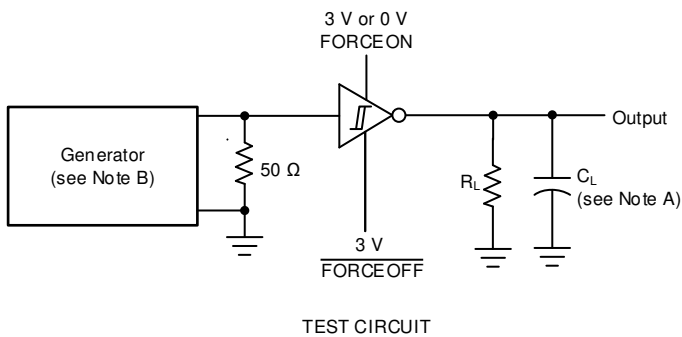

- A.  $C_L$  includes probe and jig capacitance
- B. The pulse generator has the following characteristics: PRR = 5 kbit/s,  $Z_O = 50 \Omega$ , 50 % duty cycle,  $t_r \leq 10 \text{ ns}$ ,  $t_f \leq 10 \text{ ns}$ .

**Figure 8-3. Receiver Propagation Delay Times**

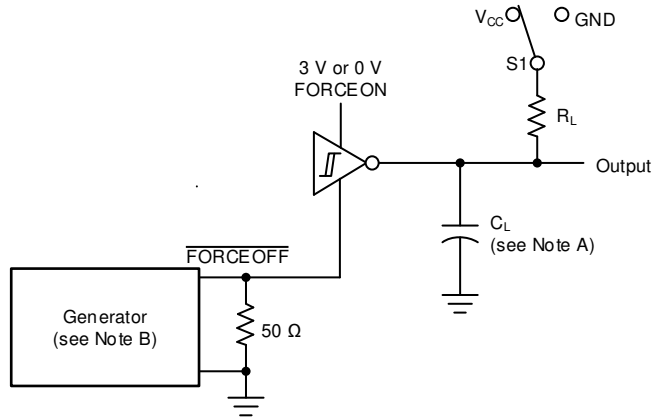

TEST CIRCUIT

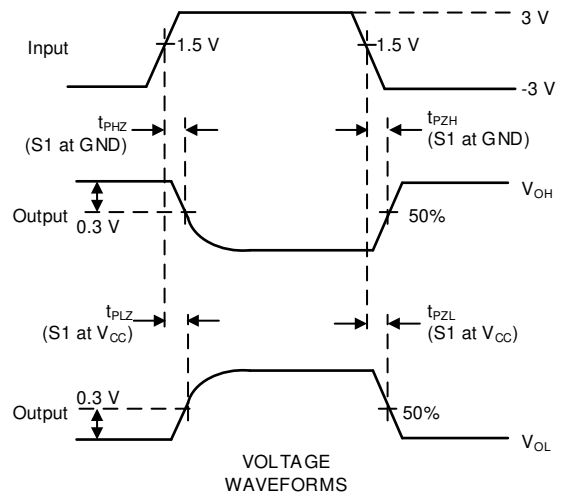

- A.  $C_L$  includes probe and jig capacitance
- B. The pulse generator has the following characteristics: PRR = 5 kbit/s,  $Z_O = 50 \Omega$ , 50 % duty cycle,  $t_r \leq 10$  ns,  $t_f \leq 10$  ns.
- C.  $t_{PLZ}$  and  $t_{PHZ}$  are the same as  $t_{dis}$ .
- D.  $t_{PZL}$  and  $t_{PZH}$  are the same as  $t_{en}$ .

Figure 8-4. Receiver Enable and Disable Times

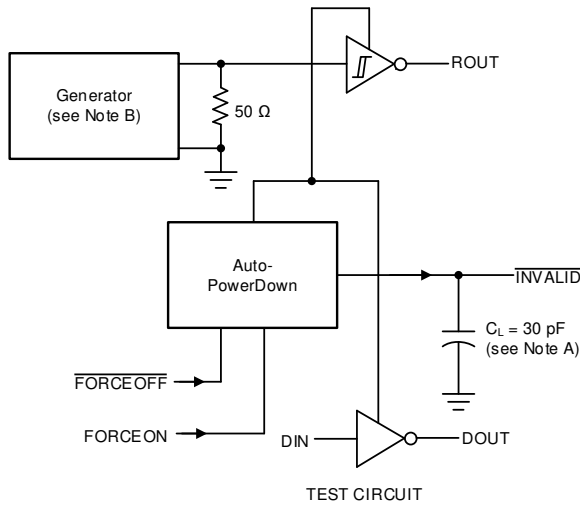

TEST CIRCUIT

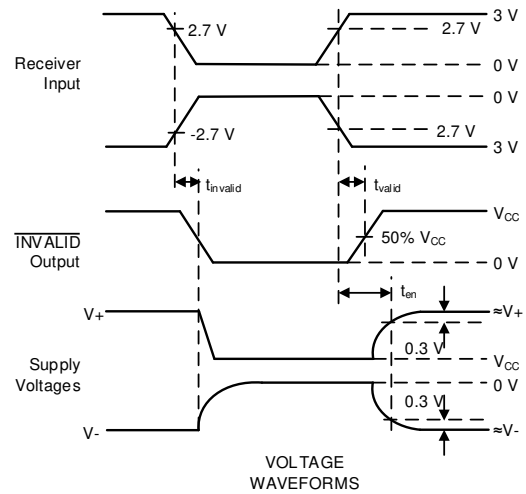

VOLTAGE WAVEFORMS

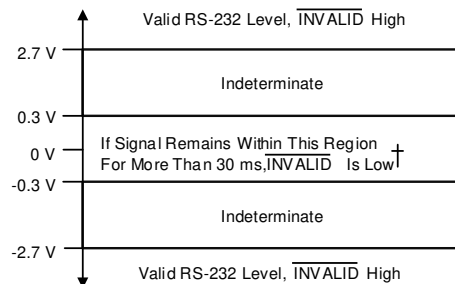

- A.  $C_L$  includes probe and jig capacitance.
- B. The pulse generator has the following characteristics: PRR = 5 kbit/s,  $Z_O = 50 \Omega$ , 50 % duty cycle,  $t_r \leq 10$  ns,  $t_f \leq 10$  ns.

Figure 8-5.  $\overline{\text{INVALID}}$  Propagation Delay Times and Supply Enabling Time

## 9 Detailed Description

### 9.1 Overview

The MAX3243E device consists of three line drivers, five line receivers, and a dual charge-pump circuit with  $\pm 15$ -kV ESD (HBM and IEC61000-4-2, Air-Gap Discharge) and  $\pm 8$ -kV ESD (IEC61000-4-2, Contact Discharge) protection on serial-port connection pins. The device meets the requirements of TIA/EIA-232-F and provides the electrical interface between an asynchronous communication controller and the serial-port connector.

The charge pump and four small external capacitors allow operation from a single 3-V to 5.5-V supply. In addition, the device includes an always-active noninverting output (ROUT2B), which allows applications using the ring indicator to transmit data while the device is powered down. The device operates at data signaling rates up to 250 kbit/s and a maximum of 30-V/ $\mu$ s driver output slew rate.

### 9.2 Functional Block Diagram

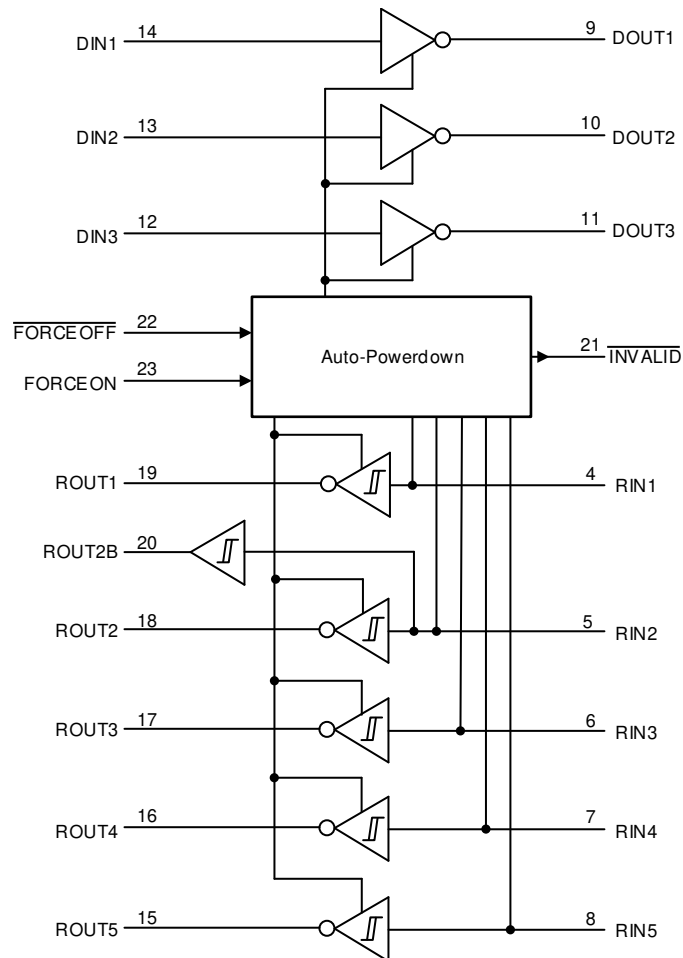

### 9.3 Feature Description

Flexible control options for power management are available when the serial port is inactive. The auto-powerdown feature functions when FORCEON is low and FORCEOFF is high. During this mode of operation, if the device does not sense a valid RS-232 signal, the driver outputs are disabled. If FORCEOFF is set low, both drivers and receivers (except ROUT2B) are shut off, and the supply current is reduced to 1  $\mu$ A. Disconnecting the serial port or turning off the peripheral drivers causes the auto-powerdown condition to occur.

Auto-powerdown can be disabled when FORCEON and FORCEOFF are high, and should be done when driving a serial mouse. With auto-powerdown enabled, the device is activated automatically when a valid signal is applied to any receiver input. The INVALID output is used to notify the user if an RS-232 signal is present at any receiver input. INVALID is high (valid data) if any receiver input voltage is greater than 2.7 V or less than -2.7 V or has been between -0.3 V and 0.3 V for less than 30  $\mu$ s. INVALID is low (invalid data) if all receiver input voltages are between -0.3 V and 0.3 V for more than 30  $\mu$ s. Refer to Figure 8-5 for receiver input levels.

### 9.4 Device Functional Modes

Figure 9-1 through 9-3 show the device functional modes.

**Table 9-1. Each Driver**

INPUTS <sup>(1)</sup>				OUTPUT		DRIVER STATUS
DIN	FORCEON	FORCEOFF	VALID RIN RS-232 LEVEL	DOUT		
X	X	L	X	Z	Powered off	
L	H	H	X	H	Normal operation with auto-powerdown disabled	
H	H	H	X	L		
L	L	H	Yes	H	Normal operation with auto-powerdown enabled	
H	L	H	Yes	L		
X	L	H	No	Z	Powered off by auto-powerdown feature	

**Table 9-2. Each Receiver**

INPUTS <sup>(1)</sup>				OUTPUT		RECEIVER STATUS
RIN	FORCEON	FORCEOFF	ROUT			
X	X	L	Z		Powered off	
L	X	H	H		Normal operation with auto-powerdown disabled/enabled	
H	X	H	L			
Open	X	H	H			

(1) H = high level, L = low level, X = irrelevant, Z = high impedance (off), Open = input disconnected or connected driver off

**Table 9-3. Outputs ROUT2B and INVALID**

INPUTS <sup>(1)</sup>					OUTPUTS		OUTPUT STATUS
VALID RIN RS-232 LEVEL	RIN2	FORCEON	FORCEOFF	INVALID	ROUT2B		
Yes	L	X	X	H	L	Always active	
Yes	H	X	X	H	H		
Yes	Open	X	X	H	L		
No	Open	X	X	L	L		

(1) H = high level, L = low level, X = irrelevant, Z = high impedance (off), Open = input disconnected or connected driver off

## 10 Application and Implementation

### Note

Information in the following applications sections is not part of the TI component specification, and TI does not warrant its accuracy or completeness. TI's customers are responsible for determining suitability of components for their purposes, as well as validating and testing their design implementation to confirm system functionality.

### 10.1 Application Information

For proper operation, add capacitors as shown in [Figure 10-1](#). Pins 12 through 23 connect to UART or general purpose logic lines. RS-232 lines on Pins 4 through 11 connect to a connector or cable.

### 10.2 Typical Application

Three driver and five receiver channels are supported for full duplex transmission with hardware flow control. The five 5-k $\Omega$  resistors are internal to the MAX3243E.

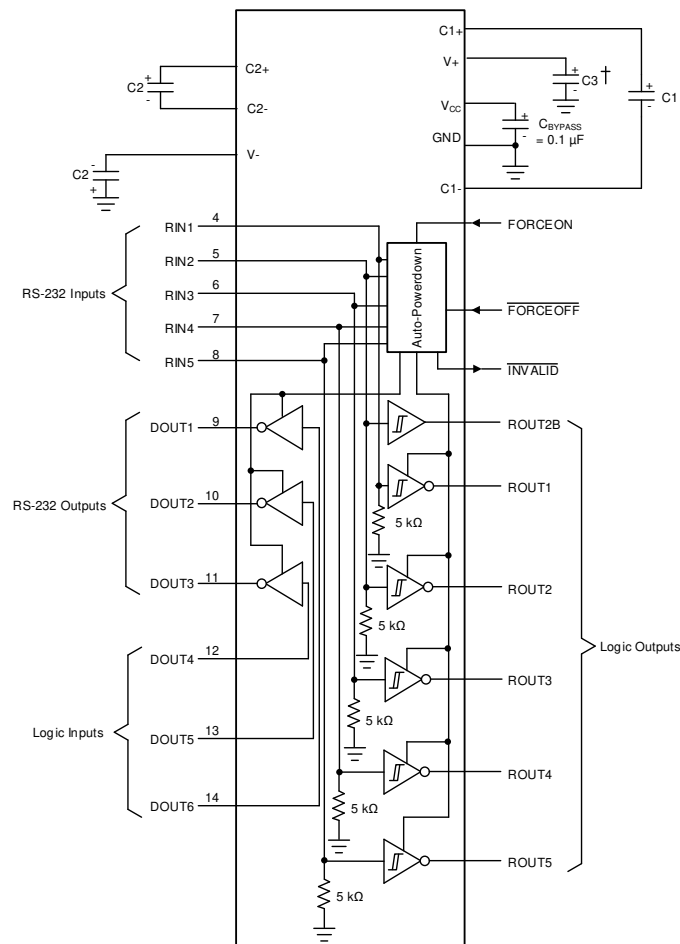

† C3 can be connected to  $V_{CC}$  or GND

- Resistor values shown are nominal.
- Nonpolarized ceramic capacitors are acceptable. If polarized tantalum or electrolytic capacitors are used, they should be connected as shown.

**Figure 10-1. Typical Operating Circuit and Capacitor Values**

### 10.2.1 Design Requirements

For this design example, use the values in [Table 10-1](#).

- $V_{CC}$  minimum is 3 V and maximum is 5.5 V.
- Maximum recommended bit rate is 250 kbps.

**Table 10-1.  $V_{CC}$  vs Capacitor Values**

$V_{CC}$	C1	C2, C3, and C4
3.3 V $\pm$ 0.3 V	0.1 $\mu$ F	0.1 $\mu$ F
5 V $\pm$ 0.5 V	0.047 $\mu$ F	0.33 $\mu$ F
3 V to 5.5 V	0.1 $\mu$ F	0.47 $\mu$ F

### 10.2.2 Detailed Design Procedure

MAX3243E has integrated charge-pump that generates positive and negative rails needed for RS-232 signal levels. Main design requirement is that charge-pump capacitor terminals must be connected with recommended capacitor values. Charge-pump rail voltages and device supply pin must be properly bypassed with ceramic capacitors.

#### 10.2.2.1 ESD Protection

TI MAX3243E devices have standard ESD protection structures incorporated on the pins to protect against electrostatic discharges encountered during assembly and handling. In addition, the RS232 bus pins (driver outputs and receiver inputs) of these devices have an extra level of ESD protection. Advanced ESD structures were designed to successfully protect these bus pins against ESD discharge of  $\pm 15$ -kV in all states: normal operation, shutdown, and powered down. The MAX3243E devices are designed to continue functioning properly after an ESD occurrence without any latchup.

The MAX3243E devices have three specified ESD limits on the driver outputs and receiver inputs, with respect to GND:

- $\pm 15$ -kV Human Body Model (HBM)
- $\pm 15$ -kV IEC61000-4-2, Air-Gap Discharge (formerly IEC1000-4-2)
- $\pm 8$ -kV IEC61000-4-2, Contact Discharge

##### 10.2.2.1.1 ESD Test Conditions

ESD testing is stringently performed by TI, based on various conditions and procedures. Please contact TI for a reliability report that documents test setup, methodology, and results.

##### 10.2.2.1.2 Human Body Model (HBM)

The Human Body Model of ESD testing is shown in [Figure 10-2](#), while [Figure 10-3](#) shows the current waveform that is generated during a discharge into a low impedance. The model consists of a 100-pF capacitor, charged to the ESD voltage of concern, and subsequently discharged into the DUT through a 1.5-k $\Omega$  resistor.

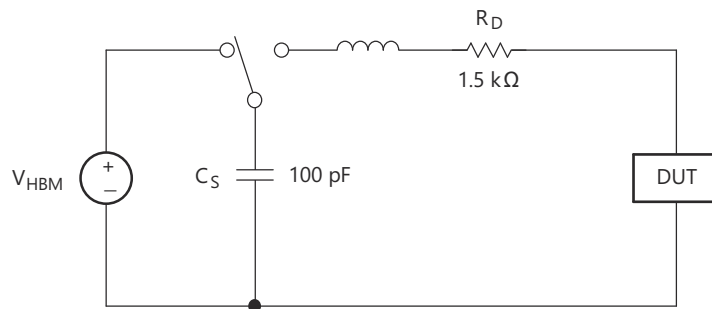

**Figure 10-2. HBM ESD Test Circuit**

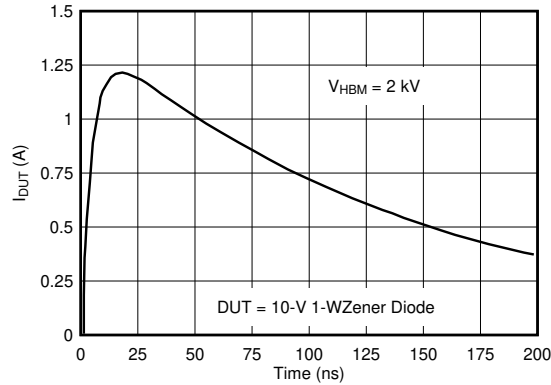
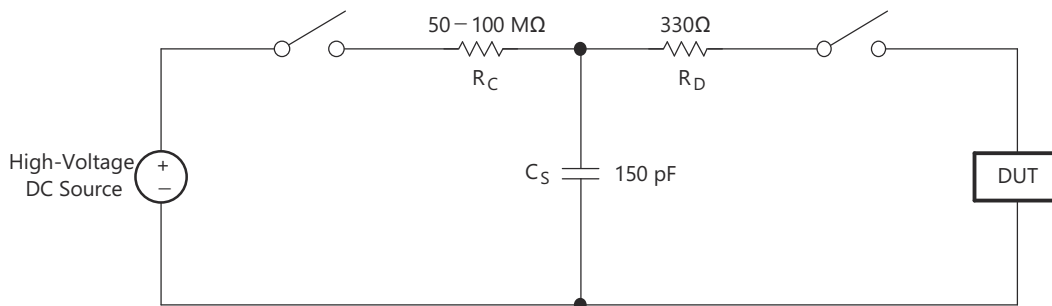

**Figure 10-3. Typical HBM Current Waveform**

**10.2.2.1.3 IEC61000-4-2 (Formerly Known as IEC1000-4-2)**

Unlike the HBM, MM, and CDM, ESD tests that apply to component level integrated circuits, the IEC61000-4-2 is a system-level ESD testing and performance standard that pertains to the end equipment. The MAX3243E device is designed to enable the manufacturer in meeting the highest level (Level 4) of IEC61000-4-2 ESD protection with no further need of external ESD protection circuitry. The more stringent IEC test standard has a higher peak current than the HBM, due to the lower series resistance in the IEC model.

Figure 10-4 shows the IEC61000-4-2 model, and Figure 10-5 shows the current waveform for the corresponding  $\pm 8$ -kV Contact-Discharge (Level 4) test. This waveform is applied to a probe that has been connected to the DUT. On the other hand, the corresponding  $\pm 15$ -kV (Level 4) Air-Gap Discharge test involves approaching the DUT with an already energized probe.



**Figure 10-4. Simplified IEC61000-4-2 ESD Test Circuit**

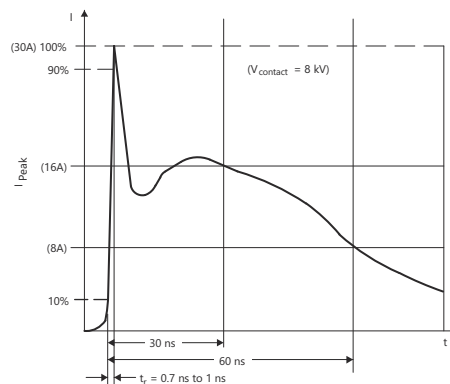

**Figure 10-5. Typical Current Waveform of IEC61000-4-2 ESD Generator**

### 10.2.2.1.4 Machine Model

The Machine Model (MM) ESD test applies to all pins using a 200-pF capacitor with no discharge resistance. The purpose of the MM test is to simulate possible ESD conditions that can occur during the handling and assembly processes of manufacturing. In this case, ESD protection is required for all pins, not just RS-232 pins. However, after PC board assembly, the MM test is no longer as pertinent to the RS-232 pins.

### 10.3 Power Supply Recommendations

The  $V_{CC}$  voltage must be connected to the same power source used for logic device connected to DIN and ROUT pins.  $V_{CC}$  must be between 3 V and 5.5 V.

### 10.4 Layout

As shown in [Layout Example](#), charge-pump and supply voltage capacitors must be located very close to device pins. Non-polarized ceramic capacitors are recommended. If polarized tantalum or electrolytic capacitors are used, they should be connected as per [Typical Operating Circuit and Capacitor Values](#).

#### 10.4.1 Layout Example

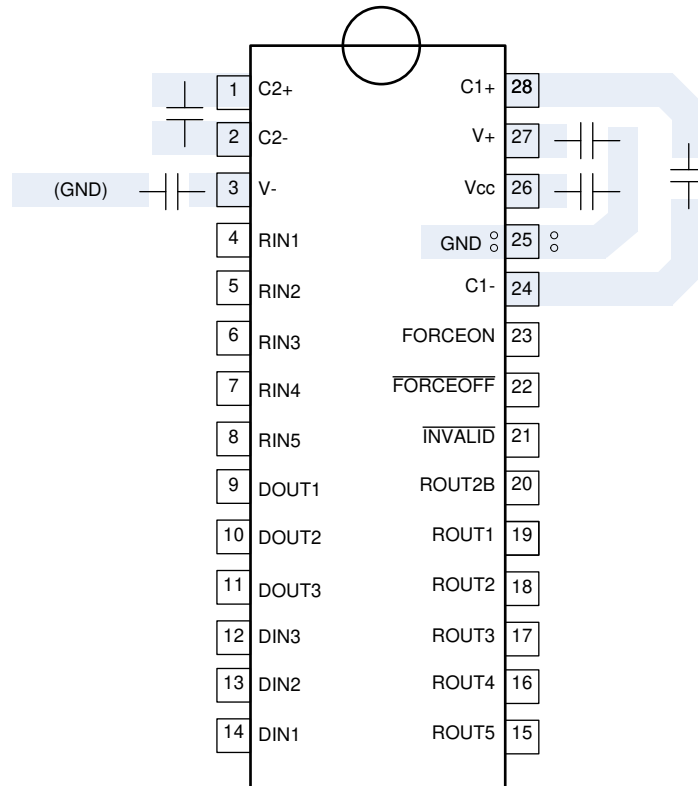

**Figure 10-6. Example Layout**

## Device and Documentation Support

### 11.1 Receiving Notification of Documentation Updates

To receive notification of documentation updates, navigate to the device product folder on ti.com. In the upper right corner, click on *Alert me* to register and receive a weekly digest of any product information that has changed. For change details, review the revision history included in any revised document.

### 11.2 Support Resources

TI E2E™ [support forums](#) are an engineer's go-to source for fast, verified answers and design help — straight from the experts. Search existing answers or ask your own question to get the quick design help you need.

Linked content is provided "AS IS" by the respective contributors. They do not constitute TI specifications and do not necessarily reflect TI's views; see TI's [Terms of Use](#).

### 11.3 Trademarks

IBM™ and PC/AT™ are trademarks of International Business Machines Corporation.

TI E2E™ is a trademark of Texas Instruments.

All trademarks are the property of their respective owners.

### 11.4 Electrostatic Discharge Caution



This integrated circuit can be damaged by ESD. Texas Instruments recommends that all integrated circuits be handled with appropriate precautions. Failure to observe proper handling and installation procedures can cause damage.

ESD damage can range from subtle performance degradation to complete device failure. Precision integrated circuits may be more susceptible to damage because very small parametric changes could cause the device not to meet its published specifications.

### 11.5 Glossary

[TI Glossary](#) This glossary lists and explains terms, acronyms, and definitions.

## 11 Mechanical, Packaging, and Orderable Information

The following pages include mechanical, packaging, and orderable information. This information is the most current data available for the designated devices. This data is subject to change without notice and revision of this document. For browser-based versions of this data sheet, refer to the left-hand navigation.

**PACKAGING INFORMATION**

Orderable Device	Status (1)	Package Type	Package Drawing	Pins	Package Qty	Eco Plan (2)	Lead finish/ Ball material (6)	MSL Peak Temp (3)	Op Temp (°C)	Device Marking (4/5)	Samples
MAX3243ECDDBR	ACTIVE	SSOP	DB	28	2000	RoHS & Green	NIPDAU	Level-1-260C-UNLIM	0 to 70	MAX3243EC	<a href="#">Samples</a>
MAX3243ECDWR	ACTIVE	SOIC	DW	28	1000	RoHS & Green	NIPDAU	Level-1-260C-UNLIM	0 to 70	MAX3243EC	<a href="#">Samples</a>
MAX3243ECPWR	ACTIVE	TSSOP	PW	28	2000	RoHS & Green	NIPDAU	Level-1-260C-UNLIM	0 to 70	MP243EC	<a href="#">Samples</a>
MAX3243ECPWRG4	ACTIVE	TSSOP	PW	28	2000	RoHS & Green	NIPDAU	Level-1-260C-UNLIM	0 to 70	MP243EC	<a href="#">Samples</a>
MAX3243ECRHBR	ACTIVE	VQFN	RHB	32	3000	RoHS & Green	NIPDAU	Level-2-260C-1 YEAR	0 to 70	MP243E	<a href="#">Samples</a>
MAX3243EIDBR	ACTIVE	SSOP	DB	28	2000	RoHS & Green	NIPDAU	Level-1-260C-UNLIM	-40 to 85	MAX3243EI	<a href="#">Samples</a>
MAX3243EIDWR	ACTIVE	SOIC	DW	28	1000	RoHS & Green	NIPDAU	Level-1-260C-UNLIM	-40 to 85	MAX3243EI	<a href="#">Samples</a>
MAX3243EIDWRG4	ACTIVE	SOIC	DW	28	1000	RoHS & Green	NIPDAU	Level-1-260C-UNLIM	-40 to 85	MAX3243EI	<a href="#">Samples</a>
MAX3243EIPWR	ACTIVE	TSSOP	PW	28	2000	RoHS & Green	NIPDAU	Level-1-260C-UNLIM	-40 to 85	MP243EI	<a href="#">Samples</a>
MAX3243EIPWRE4	ACTIVE	TSSOP	PW	28	2000	RoHS & Green	NIPDAU	Level-1-260C-UNLIM	-40 to 85	MP243EI	<a href="#">Samples</a>
MAX3243EIPWRG4	ACTIVE	TSSOP	PW	28	2000	RoHS & Green	NIPDAU	Level-1-260C-UNLIM	-40 to 85	MP243EI	<a href="#">Samples</a>
MAX3243EIRHBR	ACTIVE	VQFN	RHB	32	3000	RoHS & Green	NIPDAU	Level-2-260C-1 YEAR	-40 to 85	MR243E	<a href="#">Samples</a>
MAX3243EIRHBRG4	ACTIVE	VQFN	RHB	32	3000	RoHS & Green	NIPDAU	Level-2-260C-1 YEAR	-40 to 85	MR243E	<a href="#">Samples</a>

(1) The marketing status values are defined as follows:

**ACTIVE:** Product device recommended for new designs.

**LIFEBUY:** TI has announced that the device will be discontinued, and a lifetime-buy period is in effect.

**NRND:** Not recommended for new designs. Device is in production to support existing customers, but TI does not recommend using this part in a new design.

**PREVIEW:** Device has been announced but is not in production. Samples may or may not be available.

**OBSELETE:** TI has discontinued the production of the device.

(2) **RoHS:** TI defines "RoHS" to mean semiconductor products that are compliant with the current EU RoHS requirements for all 10 RoHS substances, including the requirement that RoHS substance do not exceed 0.1% by weight in homogeneous materials. Where designed to be soldered at high temperatures, "RoHS" products are suitable for use in specified lead-free processes. TI may reference these types of products as "Pb-Free".

**RoHS Exempt:** TI defines "RoHS Exempt" to mean products that contain lead but are compliant with EU RoHS pursuant to a specific EU RoHS exemption.

**Green:** TI defines "Green" to mean the content of Chlorine (Cl) and Bromine (Br) based flame retardants meet JS709B low halogen requirements of <=1000ppm threshold. Antimony trioxide based flame retardants must also meet the <=1000ppm threshold requirement.

- (3) MSL, Peak Temp. - The Moisture Sensitivity Level rating according to the JEDEC industry standard classifications, and peak solder temperature.
- (4) There may be additional marking, which relates to the logo, the lot trace code information, or the environmental category on the device.
- (5) Multiple Device Markings will be inside parentheses. Only one Device Marking contained in parentheses and separated by a "~" will appear on a device. If a line is indented then it is a continuation of the previous line and the two combined represent the entire Device Marking for that device.
- (6) Lead finish/Ball material - Orderable Devices may have multiple material finish options. Finish options are separated by a vertical ruled line. Lead finish/Ball material values may wrap to two lines if the finish value exceeds the maximum column width.

**Important Information and Disclaimer:**The information provided on this page represents TI's knowledge and belief as of the date that it is provided. TI bases its knowledge and belief on information provided by third parties, and makes no representation or warranty as to the accuracy of such information. Efforts are underway to better integrate information from third parties. TI has taken and continues to take reasonable steps to provide representative and accurate information but may not have conducted destructive testing or chemical analysis on incoming materials and chemicals. TI and TI suppliers consider certain information to be proprietary, and thus CAS numbers and other limited information may not be available for release.

In no event shall TI's liability arising out of such information exceed the total purchase price of the TI part(s) at issue in this document sold by TI to Customer on an annual basis.

**TAPE AND REEL INFORMATION**

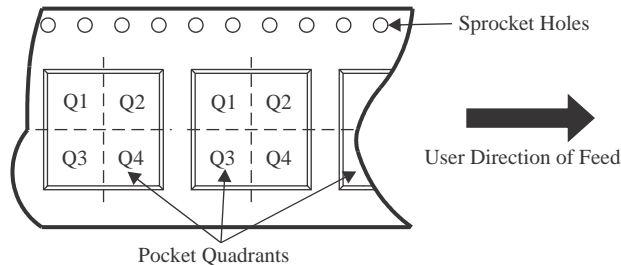
**QUADRANT ASSIGNMENTS FOR PIN 1 ORIENTATION IN TAPE**

\*All dimensions are nominal

Device	Package Type	Package Drawing	Pins	SPQ	Reel Diameter (mm)	Reel Width W1 (mm)	A0 (mm)	B0 (mm)	K0 (mm)	P1 (mm)	W (mm)	Pin1 Quadrant
MAX3243ECDBR	SSOP	DB	28	2000	330.0	16.4	8.2	10.5	2.5	12.0	16.0	Q1
MAX3243ECDWR	SOIC	DW	28	1000	330.0	32.4	11.35	18.67	3.1	16.0	32.0	Q1
MAX3243ECPWR	TSSOP	PW	28	2000	330.0	16.4	6.75	10.1	1.8	12.0	16.0	Q1
MAX3243ECPWR	TSSOP	PW	28	2000	330.0	16.4	6.9	10.2	1.8	12.0	16.0	Q1
MAX3243ECRHBR	VQFN	RHB	32	3000	330.0	12.4	5.3	5.3	1.5	8.0	12.0	Q2
MAX3243ECRHBR	VQFN	RHB	32	3000	330.0	12.4	5.3	5.3	1.1	8.0	12.0	Q2
MAX3243EIDBR	SSOP	DB	28	2000	330.0	16.4	8.2	10.5	2.5	12.0	16.0	Q1
MAX3243EIDWR	SOIC	DW	28	1000	330.0	32.4	11.35	18.67	3.1	16.0	32.0	Q1
MAX3243EIPWR	TSSOP	PW	28	2000	330.0	16.4	6.9	10.2	1.8	12.0	16.0	Q1
MAX3243EIPWR	TSSOP	PW	28	2000	330.0	16.4	6.75	10.1	1.8	12.0	16.0	Q1
MAX3243EIRHBR	VQFN	RHB	32	3000	330.0	12.4	5.3	5.3	1.1	8.0	12.0	Q2
MAX3243EIRHBR	VQFN	RHB	32	3000	330.0	12.4	5.3	5.3	1.5	8.0	12.0	Q2

**TAPE AND REEL BOX DIMENSIONS**

\*All dimensions are nominal

Device	Package Type	Package Drawing	Pins	SPQ	Length (mm)	Width (mm)	Height (mm)
MAX3243ECDBR	SSOP	DB	28	2000	356.0	356.0	35.0
MAX3243ECDWR	SOIC	DW	28	1000	350.0	350.0	66.0
MAX3243ECPWR	TSSOP	PW	28	2000	356.0	356.0	35.0
MAX3243ECPWR	TSSOP	PW	28	2000	356.0	356.0	35.0
MAX3243ECRHBR	VQFN	RHB	32	3000	356.0	356.0	35.0
MAX3243ECRHBR	VQFN	RHB	32	3000	367.0	367.0	35.0
MAX3243EIDBR	SSOP	DB	28	2000	356.0	356.0	35.0
MAX3243EIDWR	SOIC	DW	28	1000	350.0	350.0	66.0
MAX3243EIPWR	TSSOP	PW	28	2000	356.0	356.0	35.0
MAX3243EIPWR	TSSOP	PW	28	2000	356.0	356.0	35.0
MAX3243EIRHBR	VQFN	RHB	32	3000	367.0	367.0	35.0
MAX3243EIRHBR	VQFN	RHB	32	3000	356.0	356.0	35.0

# DB0028A



# PACKAGE OUTLINE

## SSOP - 2 mm max height

SMALL OUTLINE PACKAGE

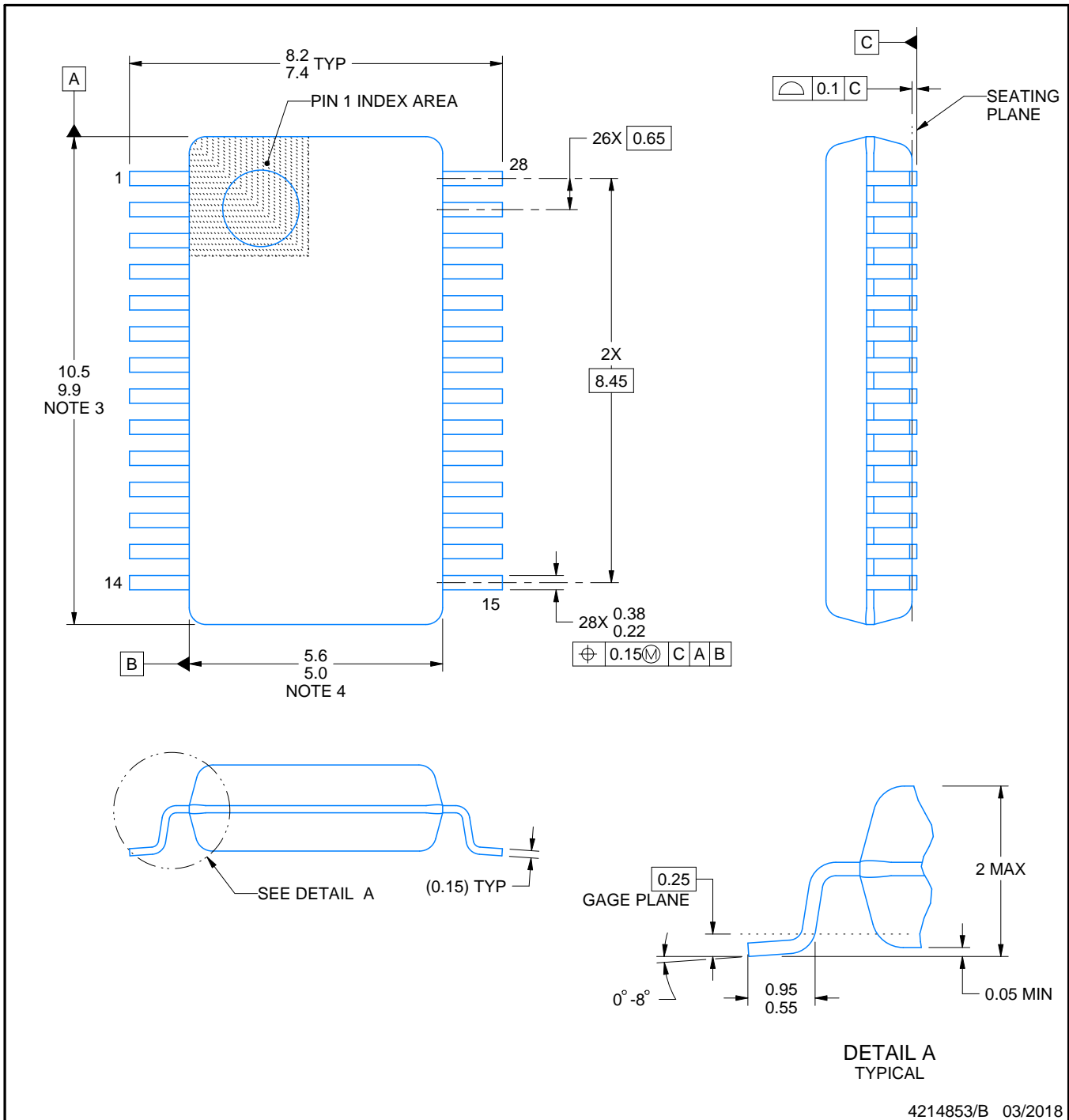

4214853/B 03/2018

### NOTES:

1. All linear dimensions are in millimeters. Any dimensions in parenthesis are for reference only. Dimensioning and tolerancing per ASME Y14.5M.
2. This drawing is subject to change without notice.
3. This dimension does not include mold flash, protrusions, or gate burrs. Mold flash, protrusions, or gate burrs shall not exceed 0.15 mm per side.
4. This dimension does not include interlead flash. Interlead flash shall not exceed 0.25 mm per side.
5. Reference JEDEC registration MO-150.

# EXAMPLE BOARD LAYOUT

DB0028A

SSOP - 2 mm max height

SMALL OUTLINE PACKAGE

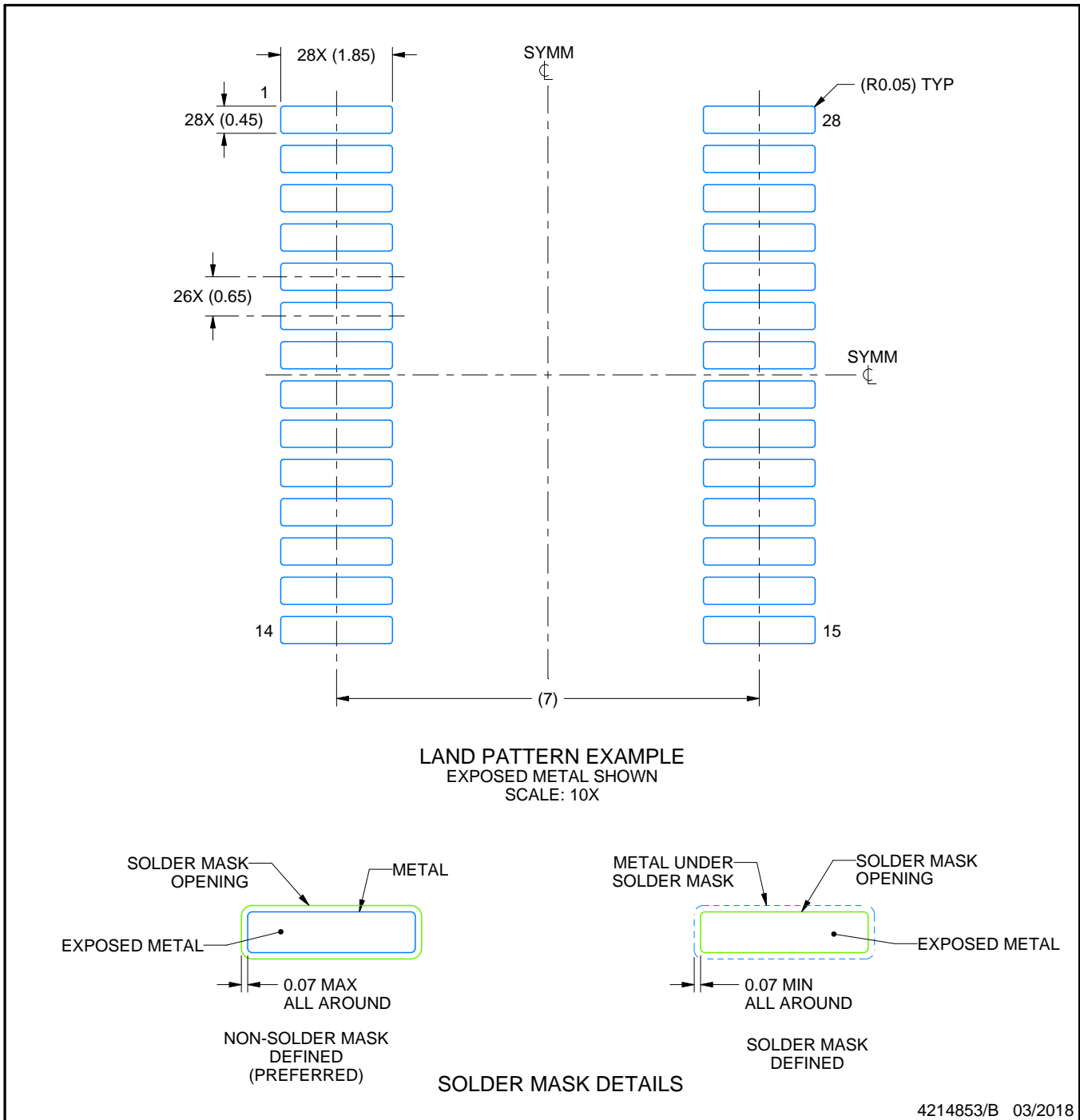

NOTES: (continued)

6. Publication IPC-7351 may have alternate designs.
7. Solder mask tolerances between and around signal pads can vary based on board fabrication site.

# EXAMPLE STENCIL DESIGN

DB0028A

SSOP - 2 mm max height

SMALL OUTLINE PACKAGE

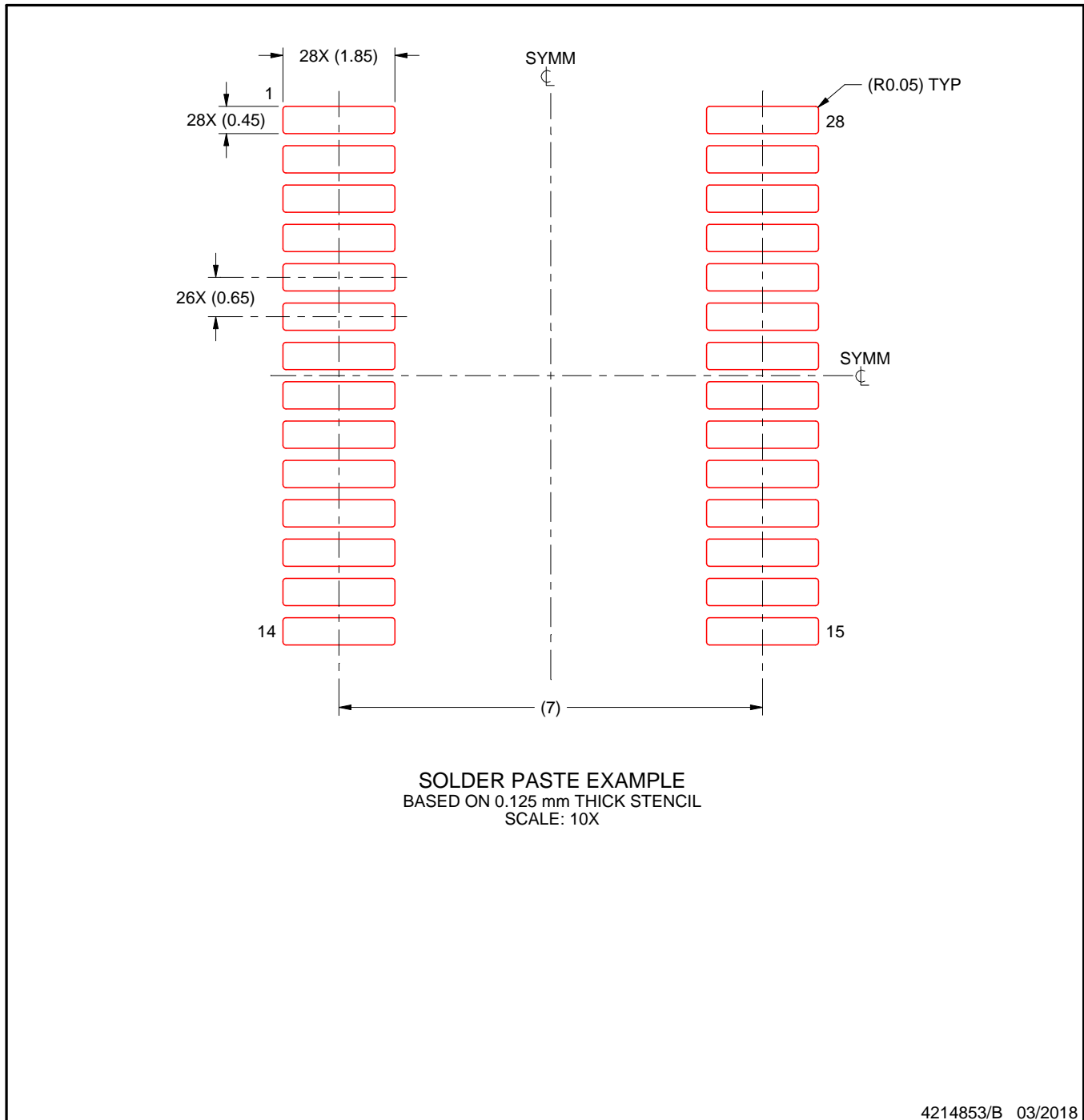

NOTES: (continued)

8. Laser cutting apertures with trapezoidal walls and rounded corners may offer better paste release. IPC-7525 may have alternate design recommendations.
9. Board assembly site may have different recommendations for stencil design.

## GENERIC PACKAGE VIEW

**RHB 32**

**VQFN - 1 mm max height**

5 x 5, 0.5 mm pitch

PLASTIC QUAD FLATPACK - NO LEAD

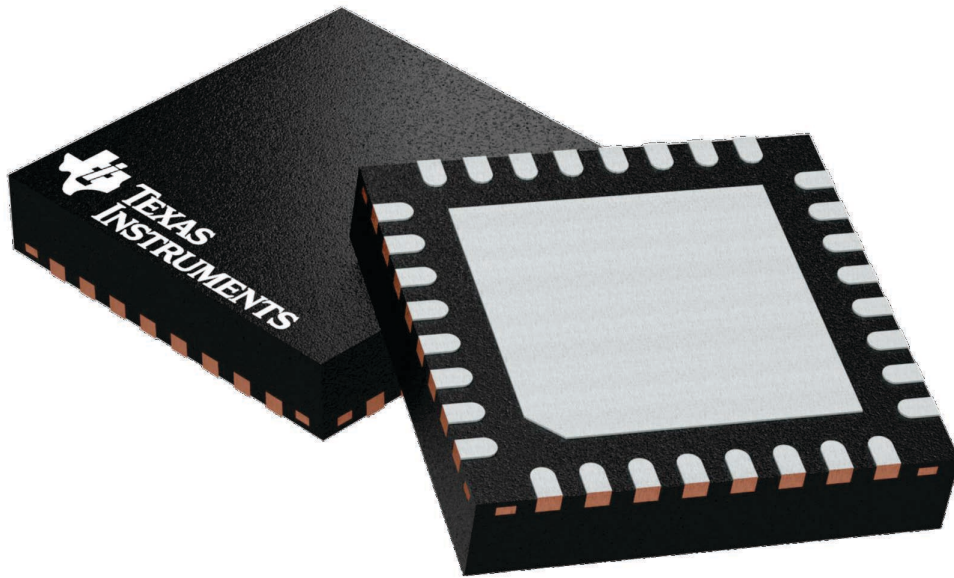

Images above are just a representation of the package family, actual package may vary.  
Refer to the product data sheet for package details.

4224745/A

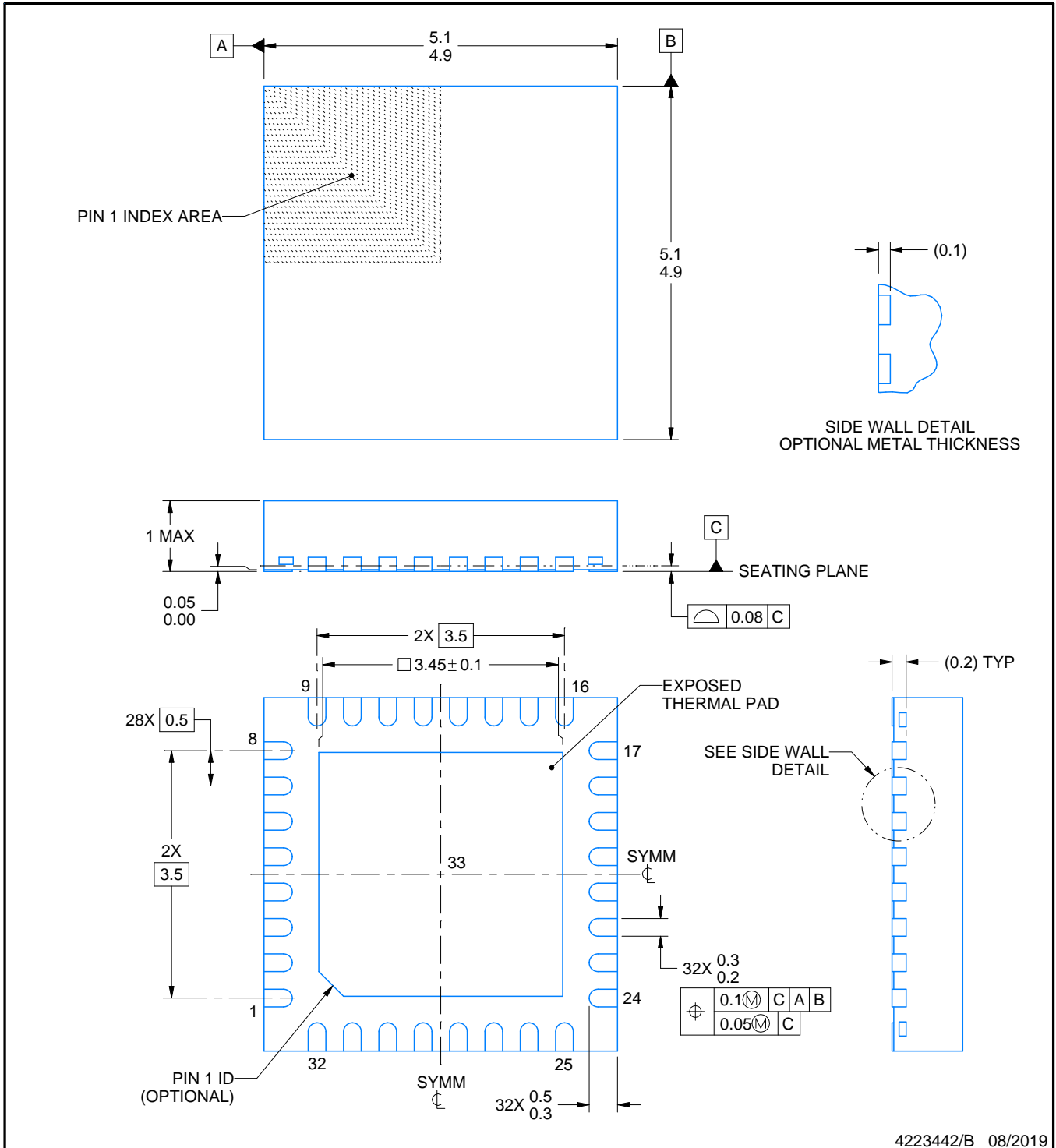
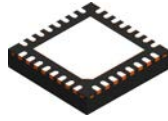

4223442/B 08/2019

NOTES:

1. All linear dimensions are in millimeters. Any dimensions in parenthesis are for reference only. Dimensioning and tolerancing per ASME Y14.5M.
2. This drawing is subject to change without notice.
3. The package thermal pad must be soldered to the printed circuit board for thermal and mechanical performance.

# EXAMPLE BOARD LAYOUT

RHB0032E

VQFN - 1 mm max height

PLASTIC QUAD FLATPACK - NO LEAD

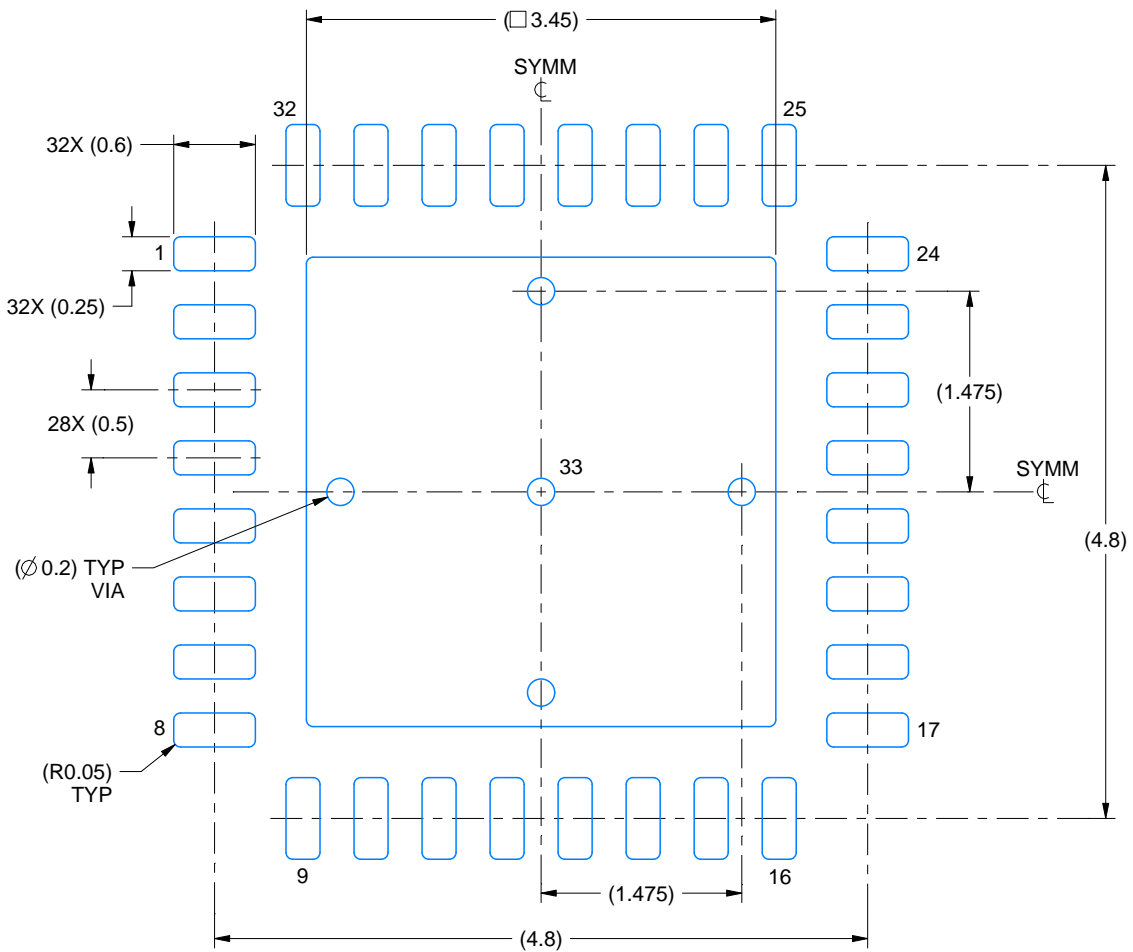

LAND PATTERN EXAMPLE  
SCALE:18X

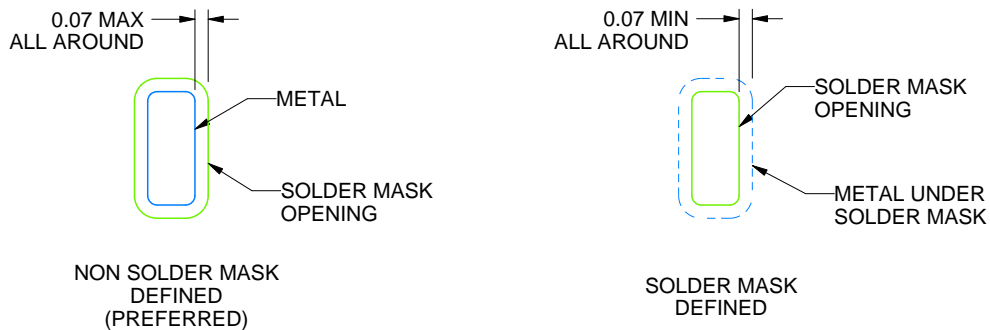

SOLDER MASK DETAILS

4223442/B 08/2019

NOTES: (continued)

4. This package is designed to be soldered to a thermal pad on the board. For more information, see Texas Instruments literature number SLUA271 ([www.ti.com/lit/sluea271](http://www.ti.com/lit/sluea271)).
5. Vias are optional depending on application, refer to device data sheet. If any vias are implemented, refer to their locations shown on this view. It is recommended that vias under paste be filled, plugged or tented.

# EXAMPLE STENCIL DESIGN

RHB0032E

VQFN - 1 mm max height

PLASTIC QUAD FLATPACK - NO LEAD

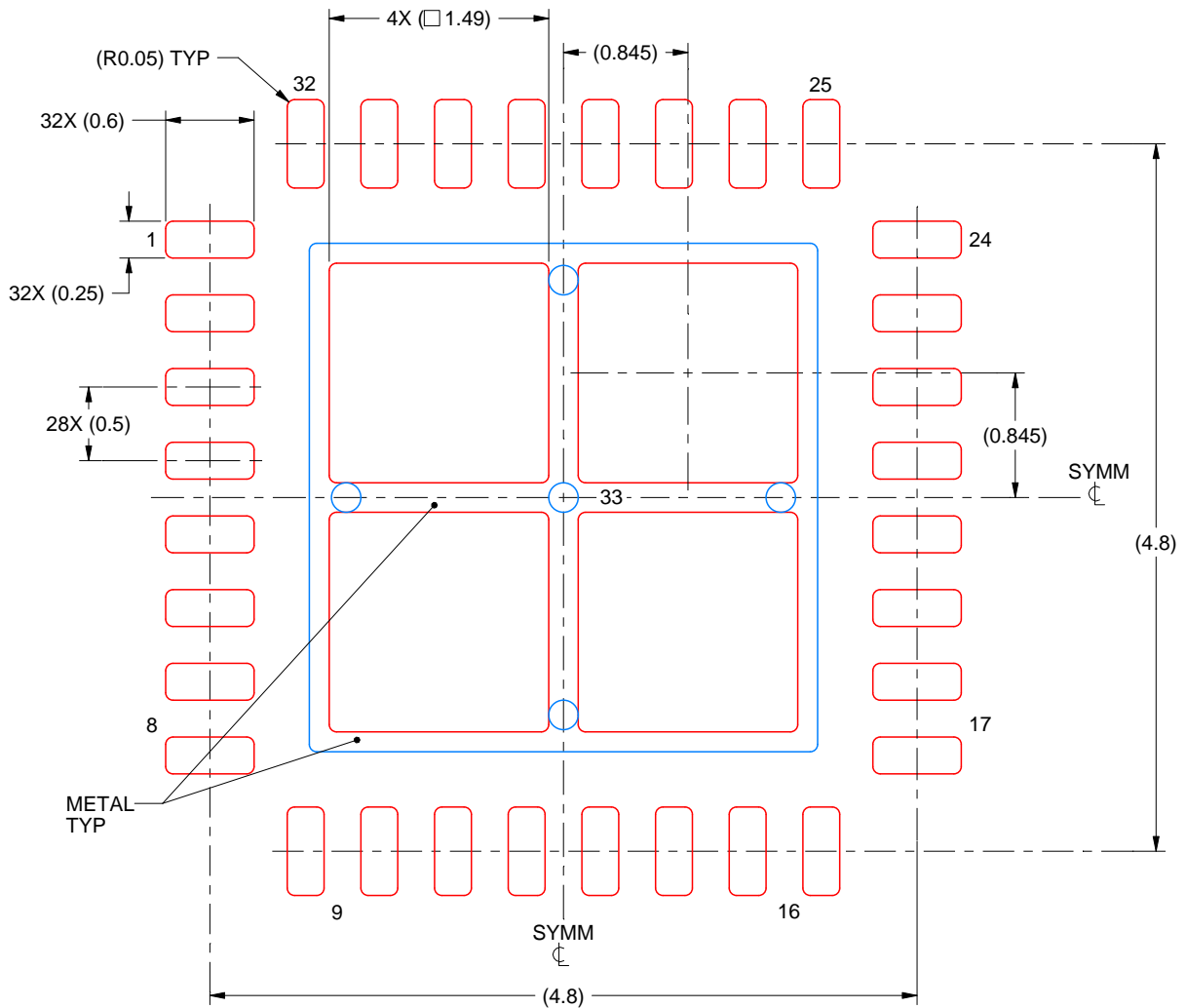

**SOLDER PASTE EXAMPLE**  
 BASED ON 0.125 mm THICK STENCIL

EXPOSED PAD 33:  
 75% PRINTED SOLDER COVERAGE BY AREA UNDER PACKAGE  
 SCALE:20X

4223442/B 08/2019

NOTES: (continued)

6. Laser cutting apertures with trapezoidal walls and rounded corners may offer better paste release. IPC-7525 may have alternate design recommendations.



# MECHANICAL DATA

PW (R-PDSO-G28)

PLASTIC SMALL OUTLINE

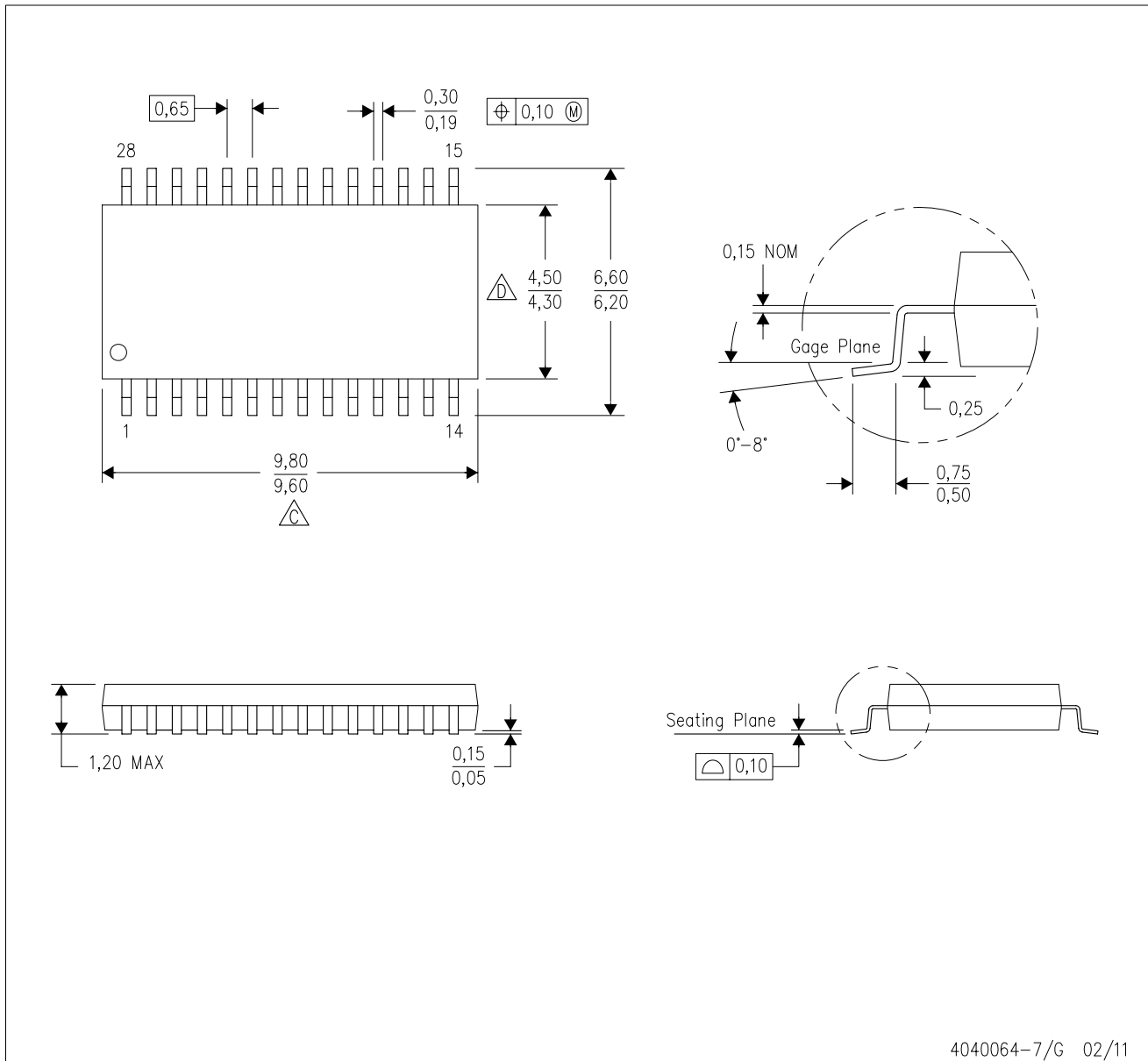

- NOTES:
- A. All linear dimensions are in millimeters. Dimensioning and tolerancing per ASME Y14.5M-1994.
  - B. This drawing is subject to change without notice.
  - C. Body length does not include mold flash, protrusions, or gate burrs. Mold flash, protrusions, or gate burrs shall not exceed 0,15 each side.
  - D. Body width does not include interlead flash. Interlead flash shall not exceed 0,25 each side.
  - E. Falls within JEDEC MO-153

PW (R-PDSO-G28)

PLASTIC SMALL OUTLINE

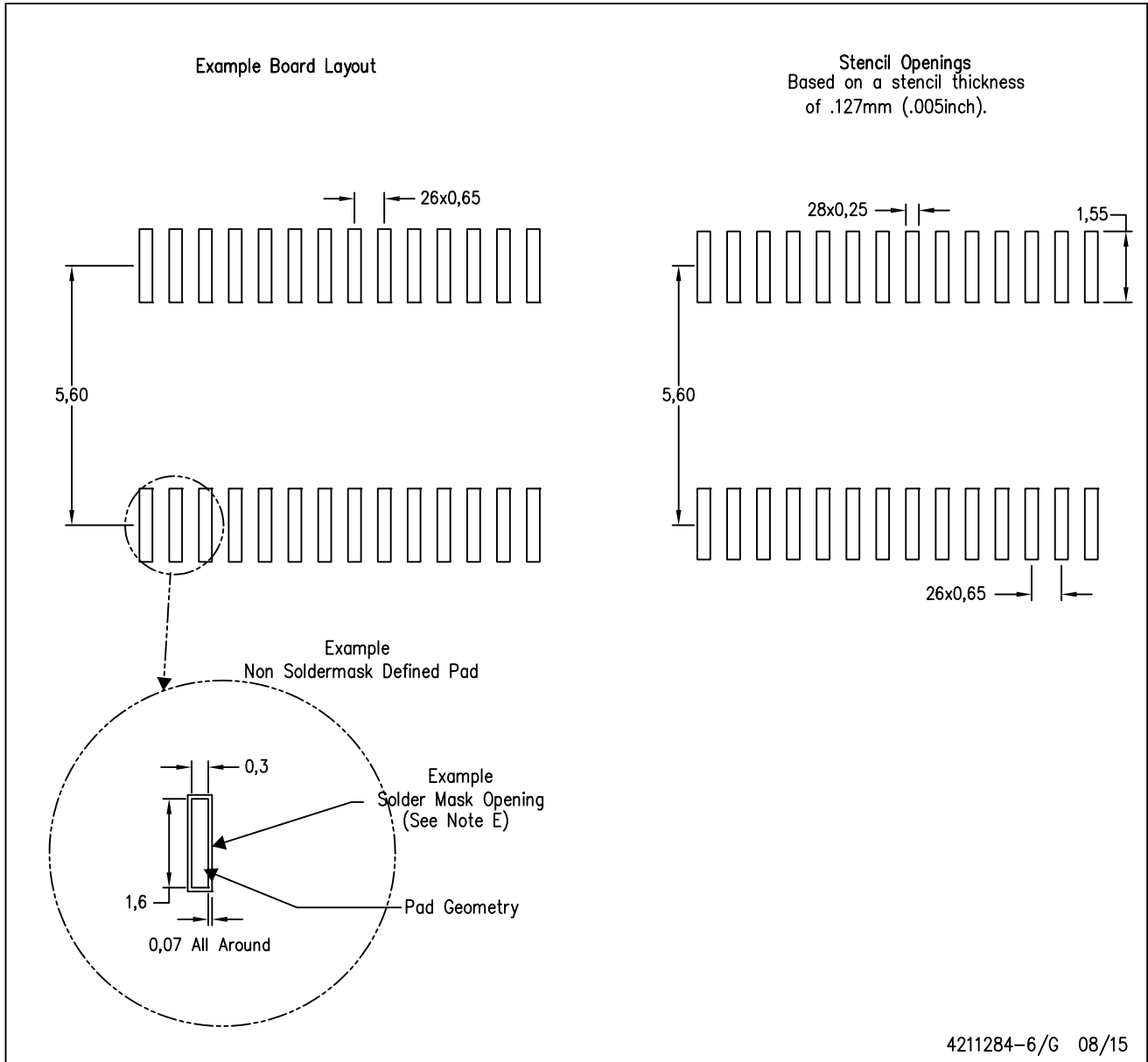

- NOTES:
- All linear dimensions are in millimeters.
  - This drawing is subject to change without notice.
  - Publication IPC-7351 is recommended for alternate design.
  - Laser cutting apertures with trapezoidal walls and also rounding corners will offer better paste release. Customers should contact their board assembly site for stencil design recommendations. Refer to IPC-7525 for other stencil recommendations.
  - Customers should contact their board fabrication site for solder mask tolerances between and around signal pads.

## IMPORTANT NOTICE AND DISCLAIMER

TI PROVIDES TECHNICAL AND RELIABILITY DATA (INCLUDING DATA SHEETS), DESIGN RESOURCES (INCLUDING REFERENCE DESIGNS), APPLICATION OR OTHER DESIGN ADVICE, WEB TOOLS, SAFETY INFORMATION, AND OTHER RESOURCES "AS IS" AND WITH ALL FAULTS, AND DISCLAIMS ALL WARRANTIES, EXPRESS AND IMPLIED, INCLUDING WITHOUT LIMITATION ANY IMPLIED WARRANTIES OF MERCHANTABILITY, FITNESS FOR A PARTICULAR PURPOSE OR NON-INFRINGEMENT OF THIRD PARTY INTELLECTUAL PROPERTY RIGHTS.

These resources are intended for skilled developers designing with TI products. You are solely responsible for (1) selecting the appropriate TI products for your application, (2) designing, validating and testing your application, and (3) ensuring your application meets applicable standards, and any other safety, security, regulatory or other requirements.

These resources are subject to change without notice. TI grants you permission to use these resources only for development of an application that uses the TI products described in the resource. Other reproduction and display of these resources is prohibited. No license is granted to any other TI intellectual property right or to any third party intellectual property right. TI disclaims responsibility for, and you will fully indemnify TI and its representatives against, any claims, damages, costs, losses, and liabilities arising out of your use of these resources.

TI's products are provided subject to [TI's Terms of Sale](#) or other applicable terms available either on [ti.com](https://www.ti.com) or provided in conjunction with such TI products. TI's provision of these resources does not expand or otherwise alter TI's applicable warranties or warranty disclaimers for TI products.

TI objects to and rejects any additional or different terms you may have proposed.

Mailing Address: Texas Instruments, Post Office Box 655303, Dallas, Texas 75265  
Copyright © 2024, Texas Instruments Incorporated

## Looking for pricing, stock, or lifecycle information?

Click below to explore more details on WIN SOURCE:

 [View MAX3243EIDBR on WIN SOURCE](#)

 [Texas Instruments](#) Information

## Optimize Your Supply Chain with WIN SOURCE Solutions

-  Global Sourcing Solution
-  Obsolete Management
-  Cost Control Management
-  Shortage Management
-  Alternative Solution
-  Excess Inventory Management