



THE DATASHEET OF MAX3243IPW



MAX3243 3-V to 5.5-V Multichannel RS-232 Line Driver/Receiver With ± 15 -kV ESD (HBM) Protection

1 Features

- Operates With 3-V to 5.5-V V_{CC} Supply
- Single-Chip and Single-Supply Interface for IBM™ PC/AT™ Serial Port
- RS-232 Bus-Pin ESD Protection of ± 15 kV Using Human-Body Model (HBM)
- Meets or Exceeds the Requirements of TIA/EIA-232-F and ITU V.28 Standards
- Three Drivers and Five Receivers
- Operates Up To 250 kbit/s
- Low Active Current: 300 μ A Typical
- Low Standby Current: 1 μ A Typical
- External Capacitors: $4 \times 0.1 \mu$ F
- Accepts 5-V Logic Input With 3.3-V Supply
- Always-Active Noninverting Receiver Output (ROUT2B)
- Operating Temperature
 - MAX3243C: 0°C to 70°C
 - MAX3243I: –40°C to 85°C
- Serial-Mouse Driveability
- Auto-Powerdown Feature to Disable Driver Outputs When No Valid RS-232 Signal Is Sensed

2 Applications

- [Battery-Powered Systems](#)
- [Tablets](#)
- [Notebooks](#)
- [Laptops](#)
- [Hand-Held Equipment](#)

3 Description

The MAX3243 device consists of three line drivers, five line receivers which is ideal for DE-9 DTE interface. ± 15 -kV ESD (HBM) protection pin to pin (serial- port connection pins, including GND). Flexible power features saves power automatically. Special outputs ROUT2B and INVALID are always enabled to allow checking for ring indicator and valid RS232 input.

Device Information

PART NUMBER	PACKAGE ⁽¹⁾	BODY SIZE
MAX3243	SSOP (28)	10.29 mm \times 5.30 mm
	SOIC (28)	17.90 mm \times 7.50 mm
	TSSOP (28)	9.70 mm \times 4.40 mm

(1) For all available packages, see the orderable addendum at the end of the data sheet.

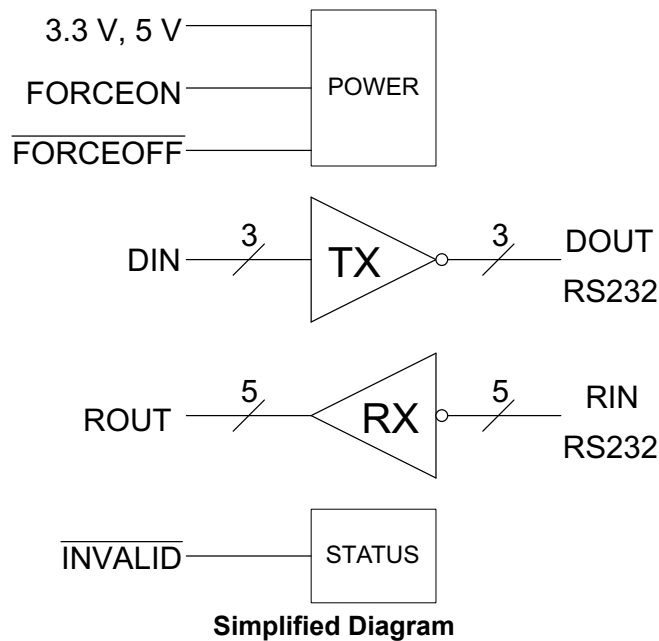

Table of Contents

1 Features	1	8 Detailed Description	10
2 Applications	1	8.1 Overview.....	10
3 Description	1	8.2 Functional Block Diagram.....	10
4 Revision History	2	8.3 Feature Description.....	11
5 Pin Configuration and Functions	3	8.4 Device Functional Modes.....	12
6 Specifications	4	9 Application and Implementation	13
6.1 Absolute Maximum Ratings.....	4	9.1 Application Information.....	13
6.2 ESD Ratings.....	4	9.2 Typical Application.....	13
6.3 Recommended Operating Conditions.....	4	9.3 Power Supply Recommendations.....	14
6.4 Thermal Information.....	5	9.4 Layout.....	14
6.5 Electrical Characteristics — Auto Power Down.....	5	10 Device and Documentation Support	16
6.6 Electrical Characteristics — Driver.....	6	10.1 Receiving Notification of Documentation Updates..	16
6.7 Electrical Characteristics — Receiver.....	6	10.2 Support Resources.....	16
6.8 Switching Characteristics — Auto Power Down.....	6	10.3 Trademarks.....	16
6.9 Switching Characteristics — Driver.....	7	10.4 Electrostatic Discharge Caution.....	16
6.10 Switching Characteristics — Receiver.....	7	10.5 Glossary.....	16
6.11 Typical Characteristics.....	7	11 Mechanical, Packaging, and Orderable Information	16
7 Parameter Measurement Information	8		

4 Revision History

Changes from Revision O (January 2015) to Revision P (October 2022)	Page
• Changed the <i>Thermal Information</i> table.....	5
• Changed the MAX value of I _{CC} Supply current auto-powerdown disabled from 1 mA to 1.2 mA in <i>Electrical Characteristics—Auto Power Down</i>	5

Changes from Revision N (May 2009) to Revision O (January 2015)	Page
• Added <i>Applications</i> , <i>Device Information</i> table, <i>Pin Functions</i> table, <i>ESD Ratings</i> table, <i>Thermal Information</i> table, <i>Typical Characteristics</i> , <i>Feature Description</i> section, <i>Device Functional Modes</i> , <i>Application and Implementation</i> section, <i>Power Supply Recommendations</i> section, <i>Layout</i> section, <i>Device and Documentation Support</i> section, and <i>Mechanical, Packaging, and Orderable Information</i> section.....	1
• Deleted <i>Ordering Information</i> table.....	1

5 Pin Configuration and Functions

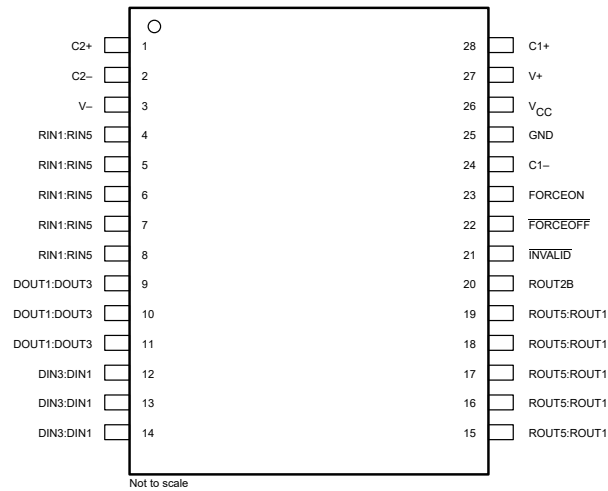

**Figure 5-1. DB, DW, or PW Package
(Top View)**

Table 5-1. Pin Functions

PIN		TYPE	DESCRIPTION
NAME	NO.		
C2+	1	—	Positive lead of C2 capacitor
C2–	2	—	Negative lead of C2 capacitor
V–	3	O	Negative charge pump output for storage capacitor only
RIN1:RIN5	4, 5, 6, 7, 8	I	RS232 line data input (from remote RS232 system)
DOUT1:DOUT3	9, 10, 11	O	RS232 line data output (to remote RS232 system)
DIN3:DIN1	12, 13, 14	I	Logic data input (from UART)
ROUT5:ROUT1	15, 16, 17, 18, 19	O	Logic data output (to UART)
ROUT2B	20	O	Always Active non-inverting output for RIN2 (normally used for ring indicator)
INVALID	21	O	Active low output when all RIN are unpowered
FORCEOFF	22	I	Low input forces DOUT1-5, ROUT1-5 high Z per Section 8.4
FORCEON	23	I	High forces drivers on. Low is automatic mode per Section 8.4
C1–	24	—	Negative lead on C1 capacitor
GND	25	—	Ground
V _{CC}	26	—	Supply Voltage, Connect to 3V to 5.5V power supply
V+	27	O	Positive charge pump output for storage capacitor only
C1+	28	—	Positive lead of C1 capacitor

6 Specifications

6.1 Absolute Maximum Ratings

over operating free-air temperature range (unless otherwise noted) ⁽¹⁾

		MIN	MAX	UNIT	
V _{CC}	Supply voltage range ⁽²⁾	-0.3	6	V	
V+	Positive output supply voltage range ⁽²⁾	-0.3	7	V	
V-	Negative output supply voltage range ⁽²⁾	0.3	-7	V	
V+ - V-	Supply voltage difference ⁽²⁾		13	V	
V _I	Input voltage range	Driver, FORCEOFF, FORCEON	-0.3	6	V
		Receiver	-25	25	
V _O	Output voltage range	Driver	-13.2	13.2	V
		Receiver, INVALID	-0.3	V _{CC} + 0.3	
T _J	Operating virtual junction temperature		150	°C	
T _{stg}	Storage temperature range	-65	150	°C	

- (1) Stresses beyond those listed under *Absolute Maximum Ratings* may cause permanent damage to the device. These are stress ratings only, and functional operation of the device at these or any other conditions beyond those indicated under [Section 6.3](#) is not implied. Exposure to absolute-maximum-rated conditions for extended periods may affect device reliability.
- (2) All voltages are with respect to network GND.

6.2 ESD Ratings

			MAX	UNIT
V _(ESD)	Electrostatic discharge	Human body model (HBM), per ANSI/ESDA/JEDEC JS-001 RIN, DOUT, and GND pins ⁽¹⁾	15000	V
		Human body model (HBM), per ANSI/ESDA/JEDEC JS-001 All other pins ⁽¹⁾	3000	
		Charged device model (CDM), per JEDEC specification JESD22-C101, all pins ⁽²⁾	1000	

- (1) JEDEC document JEP155 states that 500-V HBM allows safe manufacturing with a standard ESD control process.
- (2) JEDEC document JEP157 states that 250-V CDM allows safe manufacturing with a standard ESD control process.

6.3 Recommended Operating Conditions

⁽¹⁾ (See [Figure 9-1](#))

			MIN	NOM	MAX	UNIT
V _{CC}	Supply voltage	V _{CC} = 3.3 V	3	3.3	3.6	V
		V _{CC} = 5 V	4.5	5	5.5	
V _{IH}	Driver and control high-level input voltage	DIN, FORCEOFF, FORCEON	V _{CC} = 3.3 V	2	5.5	V
			V _{CC} = 5 V	2.4	5.5	
V _{IL}	Driver and control low-level input voltage	DIN, FORCEOFF, FORCEON	0	0.8	V	
V _I	Driver and control input voltage	DIN, FORCEOFF, FORCEON	0	5.5	V	
V _I	Receiver input voltage		-25	25	V	
T _A	Operating free-air temperature	MAX3243C	0	70	°C	
		MAX3243I	-40	85		

- (1) Test conditions are C1–C4 = 0.1 μF at V_{CC} = 3.3 V ± 0.3 V; C1 = 0.047 μF, C2–C4 = 0.33 μF at V_{CC} = 5 V ± 0.5 V.

6.4 Thermal Information

THERMAL METRIC ⁽¹⁾		DB	DW	PW	UNIT
		16 PINS	16 PINS	16 PINS	
R _{θJA}	Junction-to-ambient thermal resistance	76.1	59.0	70.3	°C/W
R _{θJC(top)}	Junction-to-case (top) thermal resistance	35.8	28.8	21.0	°C/W
R _{θJB}	Junction-to-board thermal resistance	37.4	30.3	29.2	°C/W
ψ _{JT}	Junction-to-top characterization parameter	7.4	7.8	1.3	°C/W
ψ _{JB}	Junction-to-board characterization parameter	37.0	30.0	28.8	°C/W
R _{θJC(bot)}	Junction-to-case (bottom) thermal resistance	N/A	N/A	N/A	°C/W

(1) For more information about traditional and new thermal metrics, see the *IC Package Thermal Metrics* application report (SPRA953).

6.5 Electrical Characteristics — Auto Power Down

over recommended ranges of supply voltage and operating free-air temperature (unless otherwise noted)⁽¹⁾ (see Figure 9-1)

PARAMETER		TEST CONDITIONS	MIN	TYP ⁽¹⁾	MAX	UNIT
I _{CC}	Supply current Auto-powerdown disabled	No load, $\overline{\text{FORCEOFF}}$ and FORCEON at V _{CC} . T _A = 25°C For DB and PW package		0.3	1.2	mA
	Supply current Auto-powerdown disabled	No load, $\overline{\text{FORCEOFF}}$ and FORCEON at V _{CC} . T _A = 25°C For DW package		0.3	1	mA
	Supply current Powered off	No load, $\overline{\text{FORCEOFF}}$ at GND. T _A = 25°C		1	10	μA
	Supply current Auto-powerdown enabled	No load, $\overline{\text{FORCEOFF}}$ at V _{CC} , FORCEON at GND, All RIN are open or grounded, All DIN are grounded. T _A = 25°C		1	10	
I _I	Input leakage current of $\overline{\text{FORCEOFF}}$, FORCEON	V _I = V _{CC} or V _I at GND		±0.01	±1	μA
V _{IT+}	Receiver input threshold for $\overline{\text{INVALID}}$ high-level output voltage	FORCEON = GND, $\overline{\text{FORCEOFF}}$ = V _{CC}			2.7	V
V _{IT-}	Receiver input threshold for $\overline{\text{INVALID}}$ high-level output voltage	FORCEON = GND, $\overline{\text{FORCEOFF}}$ = V _{CC}	-2.7			V
V _T	Receiver input threshold for $\overline{\text{INVALID}}$ low-level output voltage	FORCEON = GND, $\overline{\text{FORCEOFF}}$ = V _{CC}	-0.3		0.3	V
V _{OH}	$\overline{\text{INVALID}}$ high-level output voltage	I _{OH} = -1 mA, FORCEON = GND, $\overline{\text{FORCEOFF}}$ = V _{CC}	V _{CC} - 0.6			V
V _{OL}	$\overline{\text{INVALID}}$ low-level output voltage	I _{OL} = 1.6 mA, FORCEON = GND, $\overline{\text{FORCEOFF}}$ = V _{CC}			0.4	V

(1) Test conditions are C1–C4 = 0.1 μF at V_{CC} = 3.3 V ± 0.3 V; C1 = 0.047 μF, C2–C4 = 0.33 μF at V_{CC} = 5 V ± 0.5 V.

6.6 Electrical Characteristics — Driver

over recommended ranges of supply voltage and operating free-air temperature (unless otherwise noted)⁽¹⁾ (see Figure 9-1)

PARAMETER	TEST CONDITIONS	MIN	TYP ⁽²⁾	MAX	UNIT
V _{OH}	High-level output voltage	All DOUT at R _L = 3 kΩ to GND			V
V _{OL}	Low-level output voltage	All DOUT at R _L = 3 kΩ to GND			V
V _O	Output voltage (mouse driveability)	DIN1 = DIN2 = GND, DIN3 = V _{CC} , 3-kΩ to GND at DOUT3, DOUT1 = DOUT2 = 2.5 mA			V
I _{IH}	High-level input current	V _I = V _{CC}			μA
I _{IL}	Low-level input current	V _I at GND			μA
V _{hys}	Input hysteresis				V
I _{OS}	Short-circuit output current ⁽³⁾	V _{CC} = 3.6 V, V _O = 0 V		±35	±60
		V _{CC} = 5.5 V, V _O = 0 V			
r _o	Output resistance	V _{CC} , V+, and V- = 0 V, V _O = ±2 V			Ω
I _{off}	Output leakage current	FORCEOFF = GND, V _O = ±12 V, V _{CC} = 3 to 3.6 V		±25	μA
		V _O = ±10 V, V _{CC} = 4.5 to 5.5 V			

(1) Test conditions are C1–C4 = 0.1 μF at V_{CC} = 3.3 V ± 0.3 V; C1 = 0.047 μF, C2–C4 = 0.33 μF at V_{CC} = 5 V ± 0.5 V.

(2) All typical values are at V_{CC} = 3.3 V or V_{CC} = 5 V, and T_A = 25°C.

(3) Short-circuit durations should be controlled to prevent exceeding the device absolute power dissipation ratings, and not more than one output should be shorted at a time.

6.7 Electrical Characteristics — Receiver

over recommended ranges of supply voltage and operating free-air temperature (unless otherwise noted)⁽¹⁾ (see Figure 9-1)

PARAMETER	TEST CONDITIONS	MIN	TYP ⁽²⁾	MAX	UNIT
V _{OH}	High-level output voltage	I _{OH} = -1 mA			V
V _{OL}	Low-level output voltage	I _{OH} = 1.6 mA			V
V _{IT+}	Positive-going input threshold voltage	V _{CC} = 3.3 V			V
		V _{CC} = 5 V			
V _{IT-}	Negative-going input threshold voltage	V _{CC} = 3.3 V			V
		V _{CC} = 5 V			
V _{hys}	Input hysteresis (V _{IT+} - V _{IT-})				V
I _{off}	Output leakage current (except ROUT2B)	FORCEOFF = 0 V			μA
r _I	Input resistance	V _I = ±3 V or ±25 V			kΩ

(1) Test conditions are C1–C4 = 0.1 μF at V_{CC} = 3.3 V ± 0.3 V; C1 = 0.047 μF, C2–C4 = 0.33 μF at V_{CC} = 5 V ± 0.5 V.

(2) All typical values are at V_{CC} = 3.3 V or V_{CC} = 5 V, and T_A = 25°C.

6.8 Switching Characteristics — Auto Power Down

over recommended ranges of supply voltage and operating free-air temperature (unless otherwise noted) (see Figure 7-5)

PARAMETER	TEST CONDITIONS	TYP ⁽¹⁾	UNIT
t _{valid}	Propagation delay time, low- to high-level output	1	μs
t _{invalid}	Propagation delay time, high- to low-level output	30	μs
t _{en}	Supply enable time	100	μs

(1) All typical values are at V_{CC} = 3.3 V or V_{CC} = 5 V, and T_A = 25°C.

6.9 Switching Characteristics — Driver

over recommended ranges of supply voltage and operating free-air temperature (unless otherwise noted)⁽²⁾ (see Figure 9-1) MAX3243C, MAX3243I

PARAMETER		TEST CONDITIONS		MIN	TYP ⁽¹⁾	MAX	UNIT
Maximum data rate		$R_L = 3\text{ k}\Omega$ One DOUT switching,	$C_L = 1000\text{ pF}$ See Figure 7-1	150	250		kbit/s
$t_{sk(p)}$	Pulse skew ⁽³⁾	$R_L = 3\text{ k}\Omega$ to $7\text{ k}\Omega$	$C_L = 150\text{ pF}$ to 2500 pF See Figure 7-3		100		ns
SR(tr)	Slew rate, transition region (see Figure 7-1)	$V_{CC} = 3.3\text{ V}$, $R_L = 3\text{ k}\Omega$ to $7\text{ k}\Omega$	$C_L = 150\text{ pF}$ to 1000 pF	6	30		V/ μ s
			$C_L = 150\text{ pF}$ to 2500 pF	4	30		

- (1) All typical values are at $V_{CC} = 3.3\text{ V}$ or $V_{CC} = 5\text{ V}$, and $T_A = 25^\circ\text{C}$.
- (2) Test conditions are C_1 – $C_4 = 0.1\text{ }\mu\text{F}$ at $V_{CC} = 3.3\text{ V} \pm 0.3\text{ V}$; $C_1 = 0.047\text{ }\mu\text{F}$, C_2 – $C_4 = 0.33\text{ }\mu\text{F}$ at $V_{CC} = 5\text{ V} \pm 0.5\text{ V}$.
- (3) Pulse skew is defined as $|t_{PLH} - t_{PHL}|$ of each channel of the same device.

6.10 Switching Characteristics — Receiver

over recommended ranges of supply voltage and operating free-air temperature (unless otherwise noted)⁽²⁾

PARAMETER		TEST CONDITIONS	TYP ⁽¹⁾	UNIT
t_{PLH}	Propagation delay time, low- to high-level output	$C_L = 150\text{ pF}$, See Figure 7-3	150	ns
t_{PHL}	Propagation delay time, high- to low-level output		150	ns
t_{en}	Output enable time	$C_L = 150\text{ pF}$, $R_L = 3\text{ k}\Omega$, See Figure 7-4	200	ns
t_{dis}	Output disable time		200	ns
$t_{sk(p)}$	Pulse skew ⁽³⁾	See Figure 7-3	50	ns

- (1) All typical values are at $V_{CC} = 3.3\text{ V}$ or $V_{CC} = 5\text{ V}$, and $T_A = 25^\circ\text{C}$.
- (2) Test conditions are C_1 – $C_4 = 0.1\text{ }\mu\text{F}$ at $V_{CC} = 3.3\text{ V} \pm 0.3\text{ V}$; $C_1 = 0.047\text{ }\mu\text{F}$, C_2 – $C_4 = 0.33\text{ }\mu\text{F}$ at $V_{CC} = 5\text{ V} \pm 0.5\text{ V}$.
- (3) Pulse skew is defined as $|t_{PLH} - t_{PHL}|$ of each channel of the same device.

6.11 Typical Characteristics

$V_{CC} = 3.3\text{ V}$

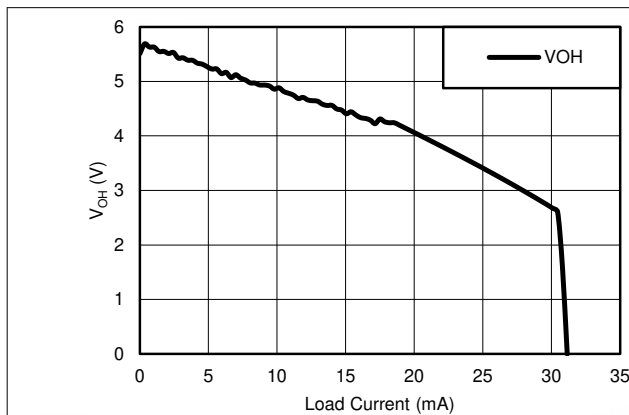

Figure 6-1. DOUT VOH vs Load Current

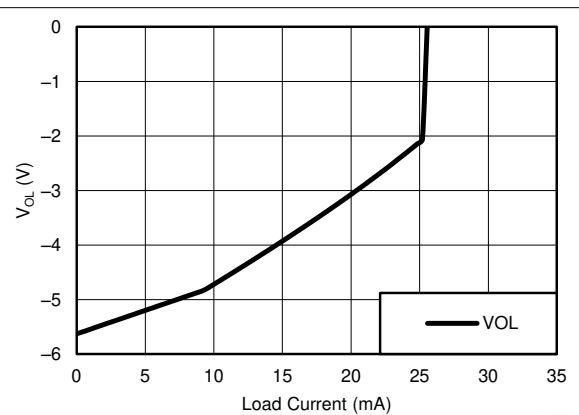
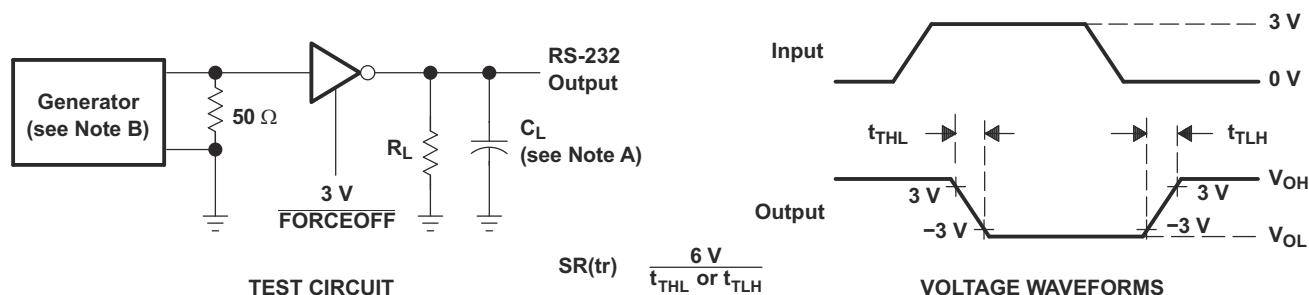

Figure 6-2. DOUT VOL vs Load Current

7 Parameter Measurement Information

7.1



NOTES: A. C_L includes probe and jig capacitance.

B. The pulse generator has the following characteristics: PRR = 250 kbit/s (MAX3243C/I) and 1 Mbit/s (MAX3243FC/I), $Z_O = 50\ \Omega$, 50% duty cycle, $t_r \leq 10\ \text{ns}$, $t_f \leq 10\ \text{ns}$.

Figure 7-1. Driver Slew Rate

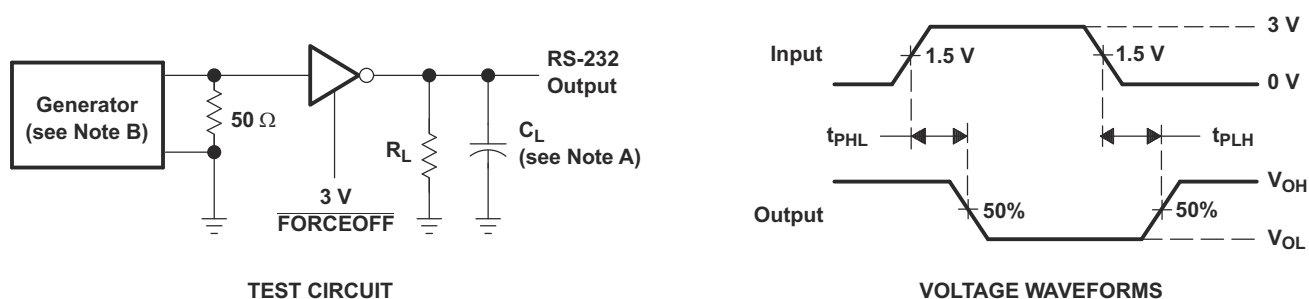

NOTES: A. C_L includes probe and jig capacitance.

B. The pulse generator has the following characteristics: PRR = 250 kbit/s (MAX3243C/I) and 1 Mbit/s (MAX3243FC/I), $Z_O = 50\ \Omega$, 50% duty cycle, $t_r \leq 10\ \text{ns}$, $t_f \leq 10\ \text{ns}$.

Figure 7-2. Driver Pulse Skew

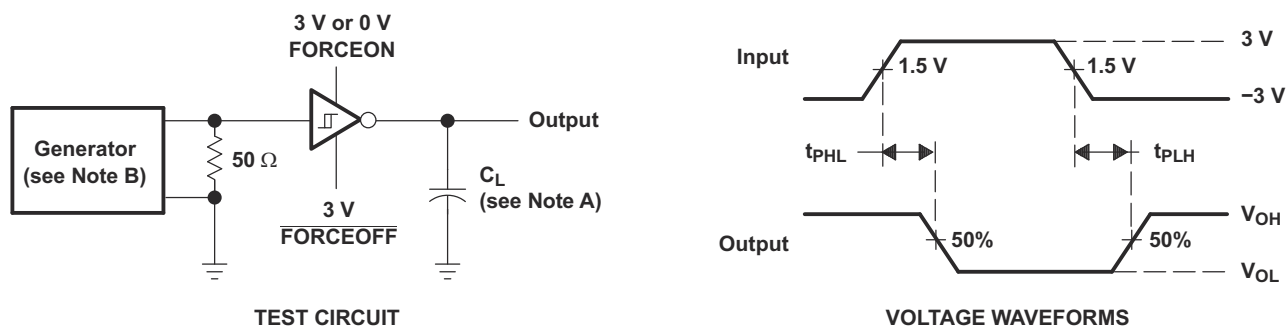

NOTES: A. C_L includes probe and jig capacitance.

B. The pulse generator has the following characteristics: $Z_O = 50\ \Omega$, 50% duty cycle, $t_r \leq 10\ \text{ns}$, $t_f \leq 10\ \text{ns}$.

Figure 7-3. Receiver Propagation Delay Times

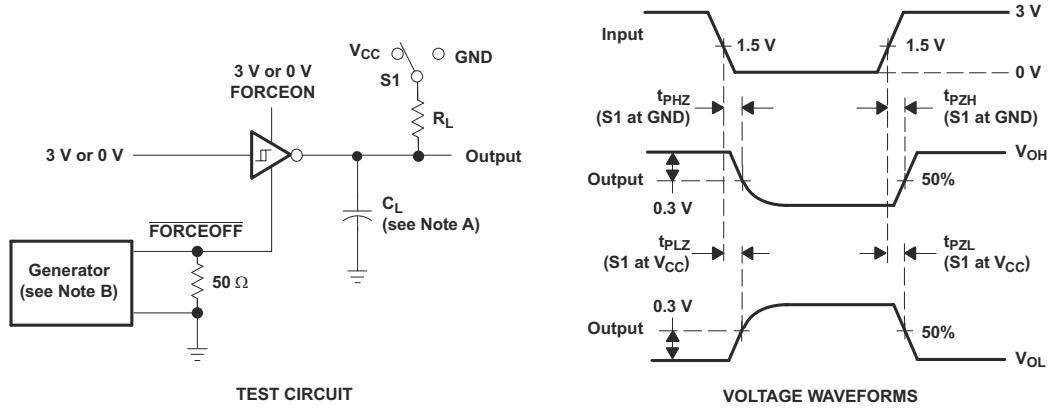

- NOTES: A. C_L includes probe and jig capacitance.
 B. The pulse generator has the following characteristics: $Z_O = 50 \Omega$, 50% duty cycle, $t_r \leq 10$ ns, $t_f \leq 10$ ns.
 C. t_{PLZ} and t_{PHZ} are the same as t_{dis} .
 D. t_{PZL} and t_{PZH} are the same as t_{en} .

Figure 7-4. Receiver Enable and Disable Times

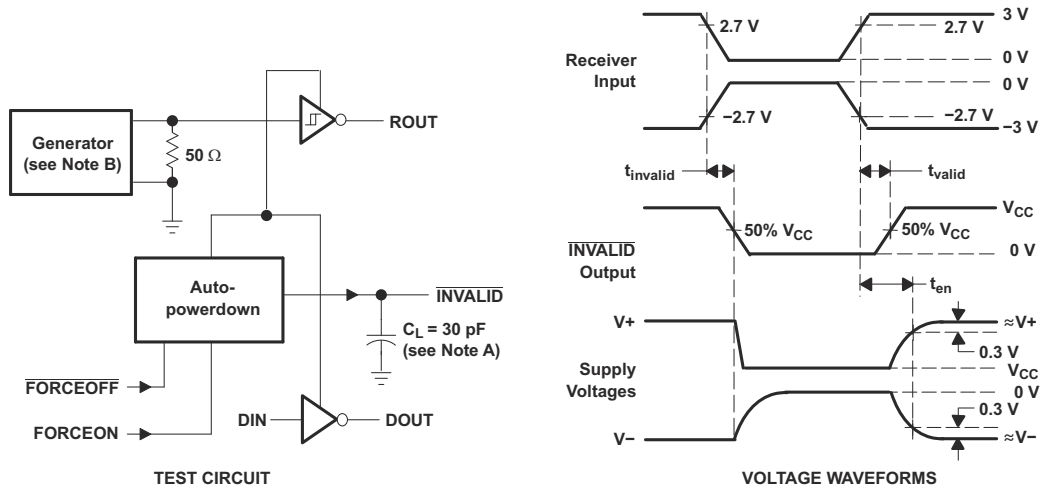

- NOTES: A. C_L includes probe and jig capacitance.
 B. The pulse generator has the following characteristics: PRR = 5 kbit/s, $Z_O = 50 \Omega$, 50% duty cycle, $t_r \leq 10$ ns, $t_f \leq 10$ ns.
 C. Auto-powerdown disables drivers and reduces supply current to $1 \mu A$.

Figure 7-5. $\overline{INVALID}$ Propagation Delay Times and Supply Enabling Time

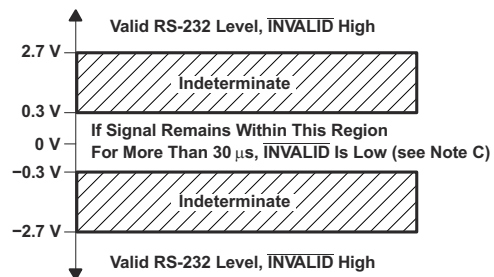

8 Detailed Description

8.1 Overview

The MAX3243 device consists of three line drivers, five line receivers, and a dual charge-pump circuit with ± 15 -kV ESD (HBM) protection pin to pin (serial-port connection pins, including GND). The device meets the requirements of TIA/EIA-232-F and provides the electrical interface between an asynchronous communication controller and the serial-port connector. This combination of drivers and receivers matches that needed for the typical serial port used in an IBM PC/AT, or compatible. The charge pump and four small external capacitors allow operation from a single 3-V to 5.5-V supply. In addition, the device includes an always-active noninverting output (ROUT2B), which allows applications using the ring indicator to transmit data while the device is powered down. Flexible control options for power management are available when the serial port is inactive. The auto-power-down feature functions when FORCEON is low and FORCEOFF is high. During this mode of operation, if the device does not sense a valid RS-232 signal, the driver outputs are disabled. If FORCEOFF is set low, both drivers and receivers (except ROUT2B) are shut off, and the supply current is reduced to 1 μ A. Disconnecting the serial port or turning off the peripheral drivers causes the auto-powerdown condition to occur. Auto-powerdown can be disabled when FORCEON and FORCEOFF are high and should be done when driving a serial mouse. With auto-powerdown enabled, the device is activated automatically when a valid signal is applied to any receiver input. The INVALID output is used to notify the user if an RS-232 signal is present at any receiver input. INVALID is high (valid data) if any receiver input voltage is greater than 2.7 V or less than -2.7 V or has been between -0.3 V and 0.3 V for less than 30 μ s. INVALID is low (invalid data) if all receiver input voltages are between -0.3 V and 0.3 V for more than 30 μ s.

8.2 Functional Block Diagram

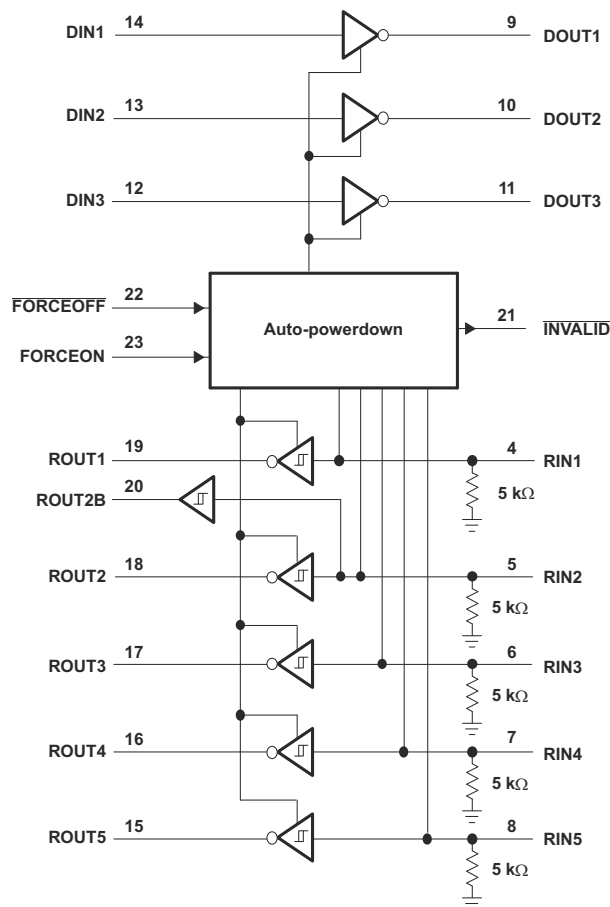

8.3 Feature Description

8.3.1 Auto-Power-Down

Auto-Power-Down can be used to automatically save power when the receivers are unconnected or connected to a powered down remote RS232 port. FORCEON being high will override Auto power down and the drivers will be active. FORCEOFF being low will override FORCEON and will power down all outputs except for ROUT2B and INVALID.

8.3.2 Charge Pump

The charge pump increases, inverts, and regulates voltage at V+ and V– pins and requires four external capacitors.

8.3.3 RS232 Driver

Three drivers interface standard logic level to RS232 levels. All DIN inputs must be valid high or low.

8.3.4 RS232 Receiver

Five receivers interface RS232 levels to standard logic levels. An open input will result in a high output on ROUT. Each RIN input includes an internal standard RS232 load.

8.3.5 ROUT2B Receiver

ROUT2B is an always-active noninverting output of RIN2 input, which allows applications using the ring indicator to transmit data while the device is powered down.

8.3.6 Invalid Input Detection

The INVALID output goes active low when all RIN inputs are unpowered. The INVALID output goes inactive high when any RIN input is connected to an active RS232 voltage level.

8.4 Device Functional Modes

Table 8-1. Each Driver⁽¹⁾

INPUTS				OUTPUT	DRIVER STATUS
DIN	FORCEON	FORCEOFF	VALID RIN RS-232 LEVEL	DOUT	
X	X	L	X	Z	Powered off
L	H	H	X	H	Normal operation with auto-powerdown disabled
H	H	H	X	L	
L	L	H	YES	H	Normal operation with auto-powerdown enabled
H	L	H	YES	L	
X	L	H	NO	Z	Power off by auto-powerdown feature

(1) H = high level, L = low level, X = irrelevant, Z = high impedance, YES = any RIN valid, NO = all RIN invalid

Table 8-2. Each Receiver⁽¹⁾

INPUTS			OUTPUTS	RECEIVER STATUS
RIN	FORCEON	FORCEOFF	ROUT	
X	X	L	Z	Powered off
L	X	H	H	Normal operation
H	X	H	L	
Open	X	H	H	

(1) H = high level, L = low level, X = irrelevant, Z = high impedance (off), Open = input disconnected or connected driver off

Table 8-3. $\overline{\text{INVALID}}$ and ROUT2B Outputs⁽¹⁾

INPUTS				OUTPUTS		OUTPUT STATUS
VALID RIN RS-232 LEVEL	RIN2	FORCEON	FORCEOFF	$\overline{\text{INVALID}}$	ROUT2B	
YES	L	X	X	H	L	Always Active
YES	H	X	X	H	H	
YES	OPEN	X	X	H	L	Always Active
NO	OPEN	X	X	L	L	

(1) H = high level, L = low level, X = irrelevant, Z = high impedance (off), OPEN = input disconnected or connected driver off, YES = any RIN valid, NO = all RIN invalid

9 Application and Implementation

Note

Information in the following applications sections is not part of the TI component specification, and TI does not warrant its accuracy or completeness. TI's customers are responsible for determining suitability of components for their purposes, as well as validating and testing their design implementation to confirm system functionality.

9.1 Application Information

It is recommended to add capacitors as shown in [Figure 9-1](#).

9.2 Typical Application

ROUT and DIN connect to UART or general purpose logic lines. RIN and DOUT lines connect to a RS232 connector or cable.

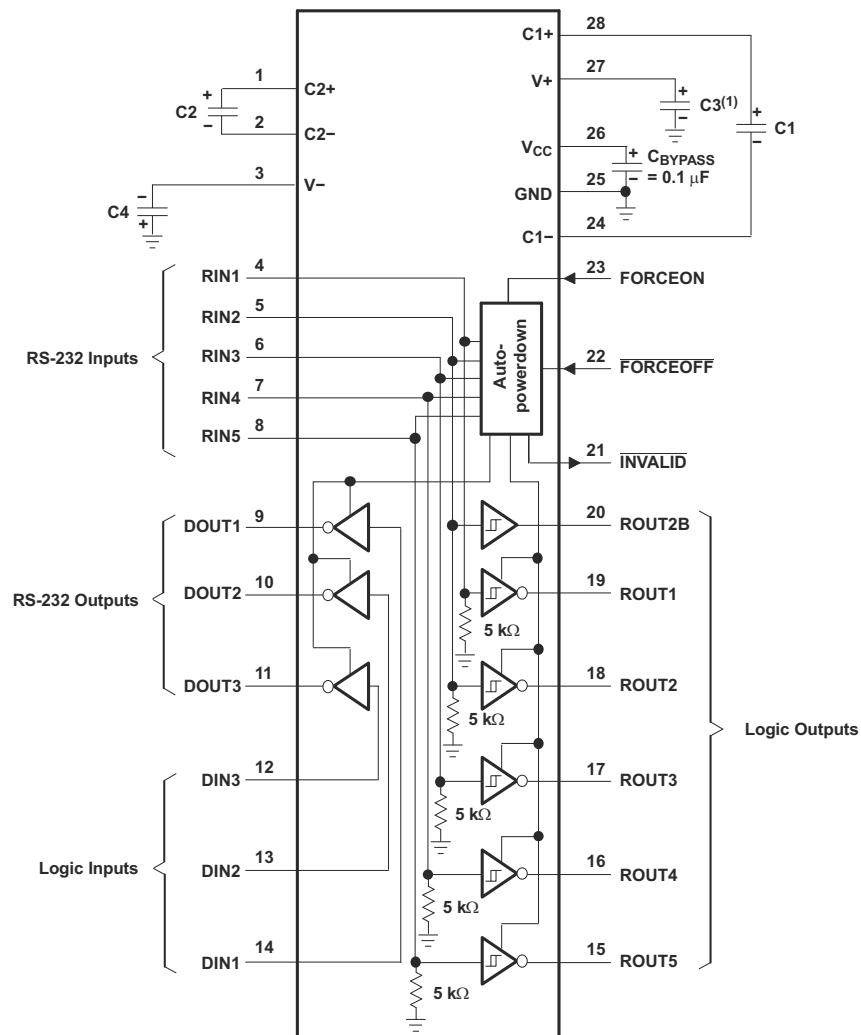

(1) C3 can be connected to V_{CC} or GND.

NOTES: A. Resistor values shown are nominal.

B. Nonpolarized ceramic capacitors are acceptable. If polarized tantalum or electrolytic capacitors are used, they should be connected as shown.

V_{CC} vs CAPACITOR VALUES

V_{CC}	C1	C2, C3, and C4
3.3 V \pm 0.3 V	0.1 μ F	0.1 μ F
5 V \pm 0.5 V	0.047 μ F	0.33 μ F
3 V to 5.5 V	0.1 μ F	0.47 μ F

Figure 9-1. Typical Operating Circuit and Capacitor Values

9.2.1 Design Requirements

- V_{CC} minimum is 3 V and maximum is 5.5V.
- Maximum recommended bit rate is 250 kbit/s.

9.2.2 Detailed Design Procedure

- All DIN, $\overline{\text{FORCEOFF}}$ and FORCEON inputs must be connected to valid low or high logic levels.
- Select capacitor values based on V_{CC} level for best performance.

9.2.3 Application Curves

$V_{CC} = 3.3$ V

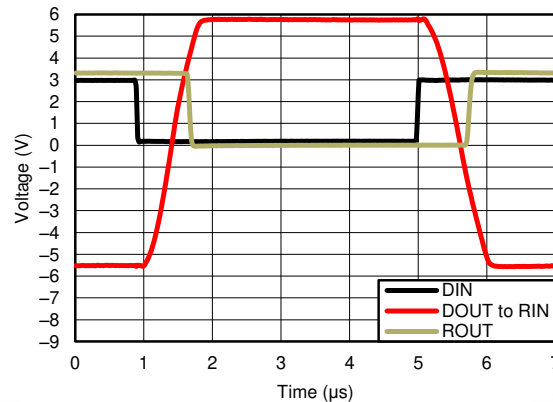

Figure 9-2. Driver to Receiver Loopback Timing Waveform

9.3 Power Supply Recommendations

V_{CC} should be between 3 V and 5.5 V. Charge pump capacitors should be chosen using table in [Figure 9-1](#).

9.4 Layout

9.4.1 Layout Guidelines

Keep the external capacitor traces short. This is more important on C1 and C2 nodes that have the fastest rise and fall times.

In the [Layout Example](#) diagram, only critical layout sections are shown. Input and output traces will vary in shape and size depending on the customer application. FORCEON and $\overline{\text{FORCEOFF}}$ should be pulled up to V_{CC} or GND via a pullup resistor, depending on which configuration the user desires upon power-up.

9.4.2 Layout Example

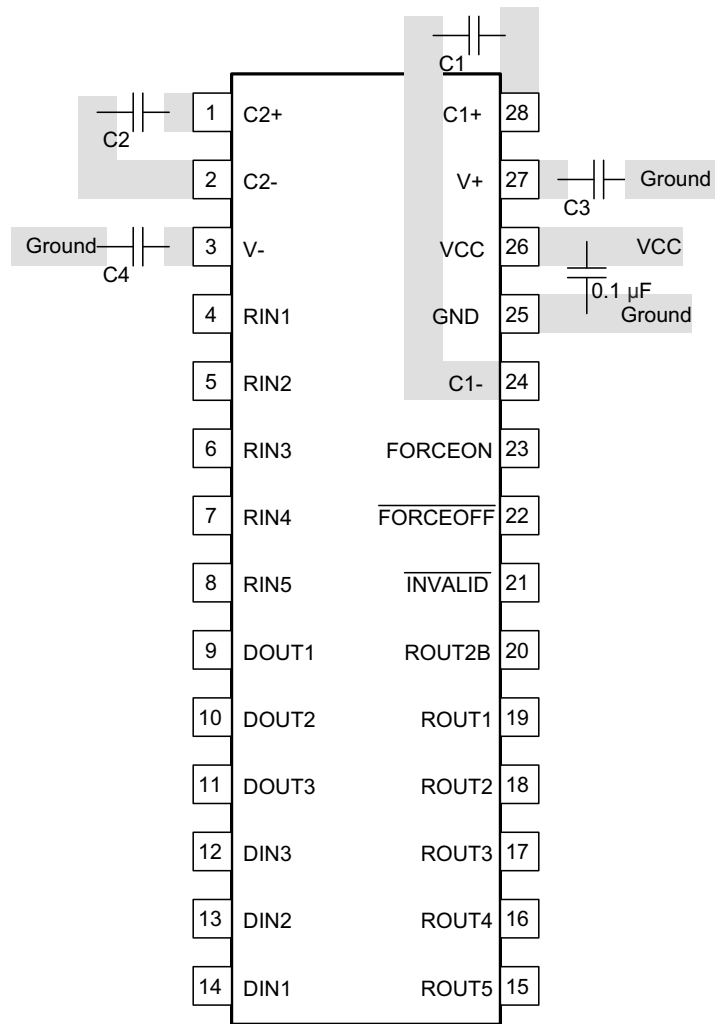

Figure 9-3. Layout Diagram

10 Device and Documentation Support

10.1 Receiving Notification of Documentation Updates

To receive notification of documentation updates, navigate to the device product folder on ti.com. Click on *Subscribe to updates* to register and receive a weekly digest of any product information that has changed. For change details, review the revision history included in any revised document.

10.2 Support Resources

TI E2E™ [support forums](#) are an engineer's go-to source for fast, verified answers and design help — straight from the experts. Search existing answers or ask your own question to get the quick design help you need.

Linked content is provided "AS IS" by the respective contributors. They do not constitute TI specifications and do not necessarily reflect TI's views; see TI's [Terms of Use](#).

10.3 Trademarks

IBM™ and PC/AT™ are trademarks of IBM.

TI E2E™ is a trademark of Texas Instruments.

All trademarks are the property of their respective owners.

10.4 Electrostatic Discharge Caution



This integrated circuit can be damaged by ESD. Texas Instruments recommends that all integrated circuits be handled with appropriate precautions. Failure to observe proper handling and installation procedures can cause damage.

ESD damage can range from subtle performance degradation to complete device failure. Precision integrated circuits may be more susceptible to damage because very small parametric changes could cause the device not to meet its published specifications.

10.5 Glossary

[TI Glossary](#) This glossary lists and explains terms, acronyms, and definitions.

11 Mechanical, Packaging, and Orderable Information

The following pages include mechanical, packaging, and orderable information. This information is the most current data available for the designated devices. This data is subject to change without notice and revision of this document. For browser-based versions of this data sheet, refer to the left-hand navigation.

PACKAGING INFORMATION

Orderable Device	Status (1)	Package Type	Package Drawing	Pins	Package Qty	Eco Plan (2)	Lead finish/ Ball material (6)	MSL Peak Temp (3)	Op Temp (°C)	Device Marking (4/5)	Samples
MAX3243CDBR	ACTIVE	SSOP	DB	28	2000	RoHS & Green	NIPDAU	Level-1-260C-UNLIM	0 to 70	MAX3243C	Samples
MAX3243CDBRE4	ACTIVE	SSOP	DB	28	2000	RoHS & Green	NIPDAU	Level-1-260C-UNLIM	0 to 70	MAX3243C	Samples
MAX3243CDBRG4	ACTIVE	SSOP	DB	28	2000	RoHS & Green	NIPDAU	Level-1-260C-UNLIM	0 to 70	MAX3243C	Samples
MAX3243CDWR	ACTIVE	SOIC	DW	28	1000	RoHS & Green	NIPDAU	Level-1-260C-UNLIM	0 to 70	MAX3243C	Samples
MAX3243CDWRG4	ACTIVE	SOIC	DW	28	1000	RoHS & Green	NIPDAU	Level-1-260C-UNLIM	0 to 70	MAX3243C	Samples
MAX3243CPWR	ACTIVE	TSSOP	PW	28	2000	RoHS & Green	NIPDAU	Level-1-260C-UNLIM	0 to 70	MA3243C	Samples
MAX3243CPWRG4	ACTIVE	TSSOP	PW	28	2000	RoHS & Green	NIPDAU	Level-1-260C-UNLIM	0 to 70	MA3243C	Samples
MAX3243IDBR	ACTIVE	SSOP	DB	28	2000	RoHS & Green	NIPDAU	Level-1-260C-UNLIM	-40 to 85	MAX3243I	Samples
MAX3243IDW	ACTIVE	SOIC	DW	28	20	RoHS & Green	NIPDAU	Level-1-260C-UNLIM	-40 to 85	MAX3243I	Samples
MAX3243IDWR	ACTIVE	SOIC	DW	28	1000	RoHS & Green	NIPDAU SN	Level-1-260C-UNLIM	-40 to 85	MAX3243I	Samples
MAX3243IPWR	ACTIVE	TSSOP	PW	28	2000	RoHS & Green	NIPDAU	Level-1-260C-UNLIM	-40 to 85	MB3243I	Samples
MAX3243IPWRE4	ACTIVE	TSSOP	PW	28	2000	RoHS & Green	NIPDAU	Level-1-260C-UNLIM	-40 to 85	MB3243I	Samples

(1) The marketing status values are defined as follows:

ACTIVE: Product device recommended for new designs.

LIFEBUY: TI has announced that the device will be discontinued, and a lifetime-buy period is in effect.

NRND: Not recommended for new designs. Device is in production to support existing customers, but TI does not recommend using this part in a new design.

PREVIEW: Device has been announced but is not in production. Samples may or may not be available.

OBSOLETE: TI has discontinued the production of the device.

(2) **RoHS:** TI defines "RoHS" to mean semiconductor products that are compliant with the current EU RoHS requirements for all 10 RoHS substances, including the requirement that RoHS substance do not exceed 0.1% by weight in homogeneous materials. Where designed to be soldered at high temperatures, "RoHS" products are suitable for use in specified lead-free processes. TI may reference these types of products as "Pb-Free".

RoHS Exempt: TI defines "RoHS Exempt" to mean products that contain lead but are compliant with EU RoHS pursuant to a specific EU RoHS exemption.

Green: TI defines "Green" to mean the content of Chlorine (Cl) and Bromine (Br) based flame retardants meet JS709B low halogen requirements of <=1000ppm threshold. Antimony trioxide based flame retardants must also meet the <=1000ppm threshold requirement.

- (3) MSL, Peak Temp. - The Moisture Sensitivity Level rating according to the JEDEC industry standard classifications, and peak solder temperature.
- (4) There may be additional marking, which relates to the logo, the lot trace code information, or the environmental category on the device.
- (5) Multiple Device Markings will be inside parentheses. Only one Device Marking contained in parentheses and separated by a "~" will appear on a device. If a line is indented then it is a continuation of the previous line and the two combined represent the entire Device Marking for that device.
- (6) Lead finish/Ball material - Orderable Devices may have multiple material finish options. Finish options are separated by a vertical ruled line. Lead finish/Ball material values may wrap to two lines if the finish value exceeds the maximum column width.

Important Information and Disclaimer:The information provided on this page represents TI's knowledge and belief as of the date that it is provided. TI bases its knowledge and belief on information provided by third parties, and makes no representation or warranty as to the accuracy of such information. Efforts are underway to better integrate information from third parties. TI has taken and continues to take reasonable steps to provide representative and accurate information but may not have conducted destructive testing or chemical analysis on incoming materials and chemicals. TI and TI suppliers consider certain information to be proprietary, and thus CAS numbers and other limited information may not be available for release.

In no event shall TI's liability arising out of such information exceed the total purchase price of the TI part(s) at issue in this document sold by TI to Customer on an annual basis.

OTHER QUALIFIED VERSIONS OF MAX3243 :

- Enhanced Product : [MAX3243-EP](#)

NOTE: Qualified Version Definitions:

- Enhanced Product - Supports Defense, Aerospace and Medical Applications

TAPE AND REEL INFORMATION

QUADRANT ASSIGNMENTS FOR PIN 1 ORIENTATION IN TAPE



*All dimensions are nominal

Device	Package Type	Package Drawing	Pins	SPQ	Reel Diameter (mm)	Reel Width W1 (mm)	A0 (mm)	B0 (mm)	K0 (mm)	P1 (mm)	W (mm)	Pin1 Quadrant
MAX3243CDBR	SSOP	DB	28	2000	330.0	16.4	8.2	10.5	2.5	12.0	16.0	Q1
MAX3243CDWR	SOIC	DW	28	1000	330.0	32.4	11.35	18.67	3.1	16.0	32.0	Q1
MAX3243CPWR	TSSOP	PW	28	2000	330.0	16.4	6.9	10.2	1.8	12.0	16.0	Q1
MAX3243IDBR	SSOP	DB	28	2000	330.0	16.4	8.2	10.5	2.5	12.0	16.0	Q1
MAX3243IDWR	SOIC	DW	28	1000	330.0	32.4	11.35	18.67	3.1	16.0	32.0	Q1
MAX3243IPWR	TSSOP	PW	28	2000	330.0	16.4	6.9	10.2	1.8	12.0	16.0	Q1

TAPE AND REEL BOX DIMENSIONS

*All dimensions are nominal

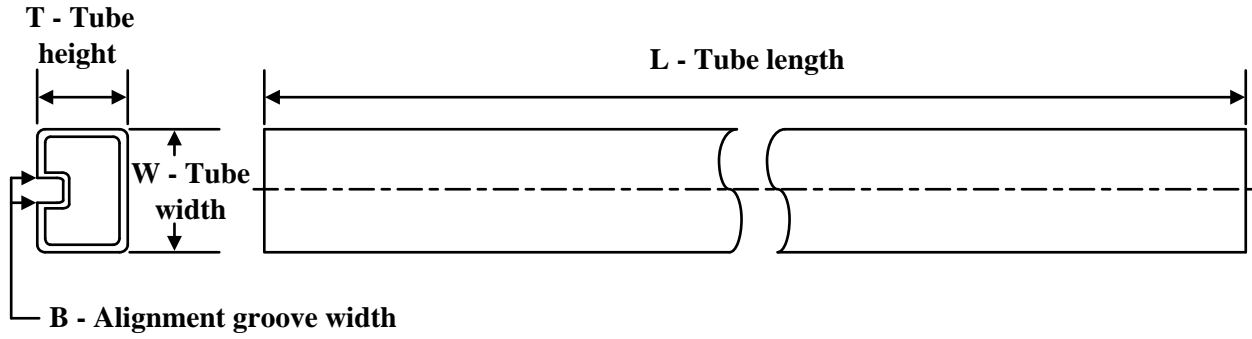
Device	Package Type	Package Drawing	Pins	SPQ	Length (mm)	Width (mm)	Height (mm)
MAX3243CDBR	SSOP	DB	28	2000	356.0	356.0	35.0
MAX3243CDWR	SOIC	DW	28	1000	350.0	350.0	66.0
MAX3243CPWR	TSSOP	PW	28	2000	356.0	356.0	35.0
MAX3243IDBR	SSOP	DB	28	2000	356.0	356.0	35.0
MAX3243IDWR	SOIC	DW	28	1000	350.0	350.0	66.0
MAX3243IPWR	TSSOP	PW	28	2000	356.0	356.0	35.0

TUBE

*All dimensions are nominal

Device	Package Name	Package Type	Pins	SPQ	L (mm)	W (mm)	T (μm)	B (mm)
MAX3243IDW	DW	SOIC	28	20	506.98	12.7	4826	6.6

DW (R-PDSO-G28)

PLASTIC SMALL OUTLINE

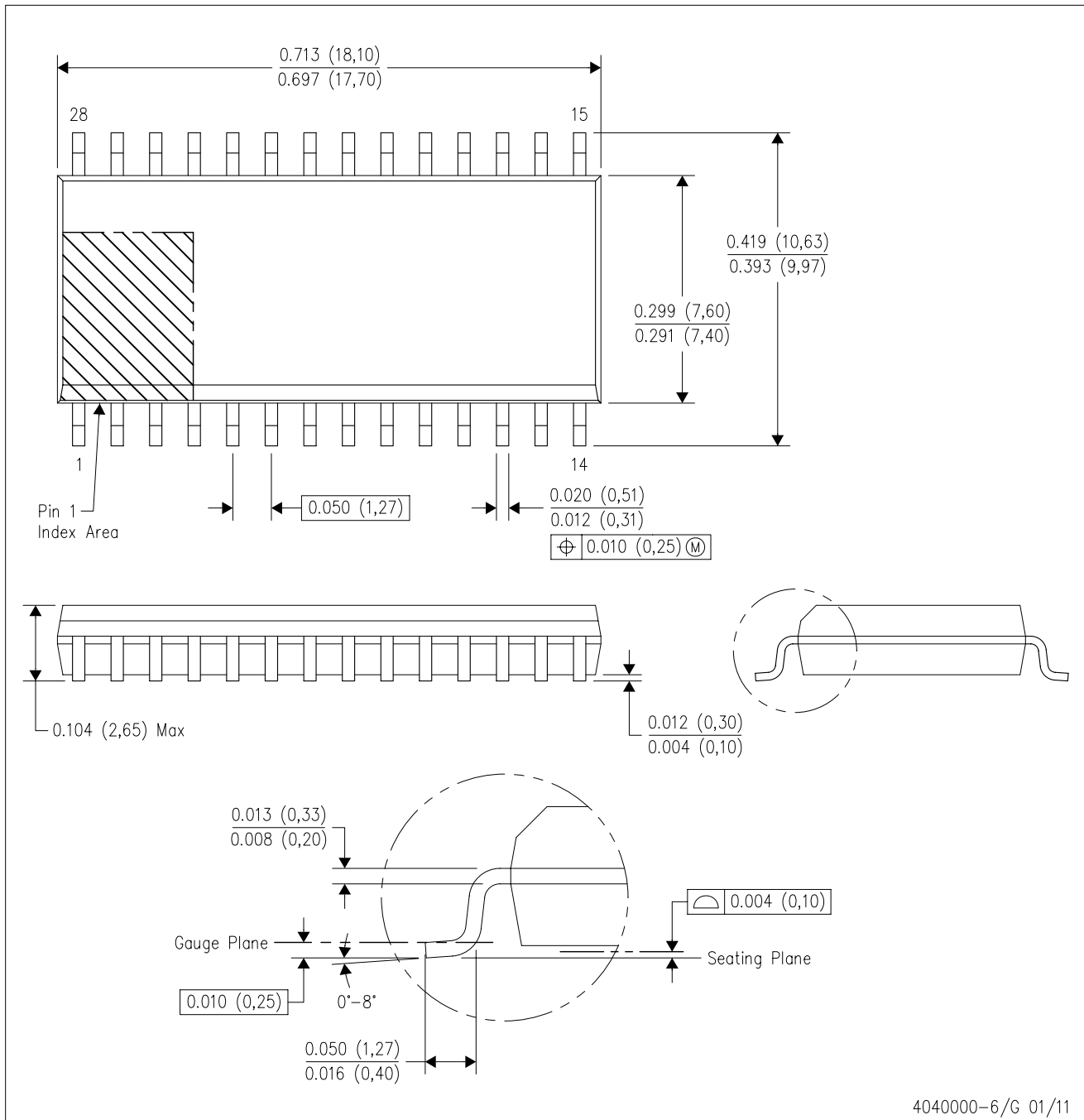

4040000-6/G 01/11

- NOTES:
- All linear dimensions are in inches (millimeters). Dimensioning and tolerancing per ASME Y14.5M-1994.
 - This drawing is subject to change without notice.
 - Body dimensions do not include mold flash or protrusion not to exceed 0.006 (0,15).
 - Falls within JEDEC MS-013 variation AE.

DW (R-PDSO-G28)

PLASTIC SMALL OUTLINE

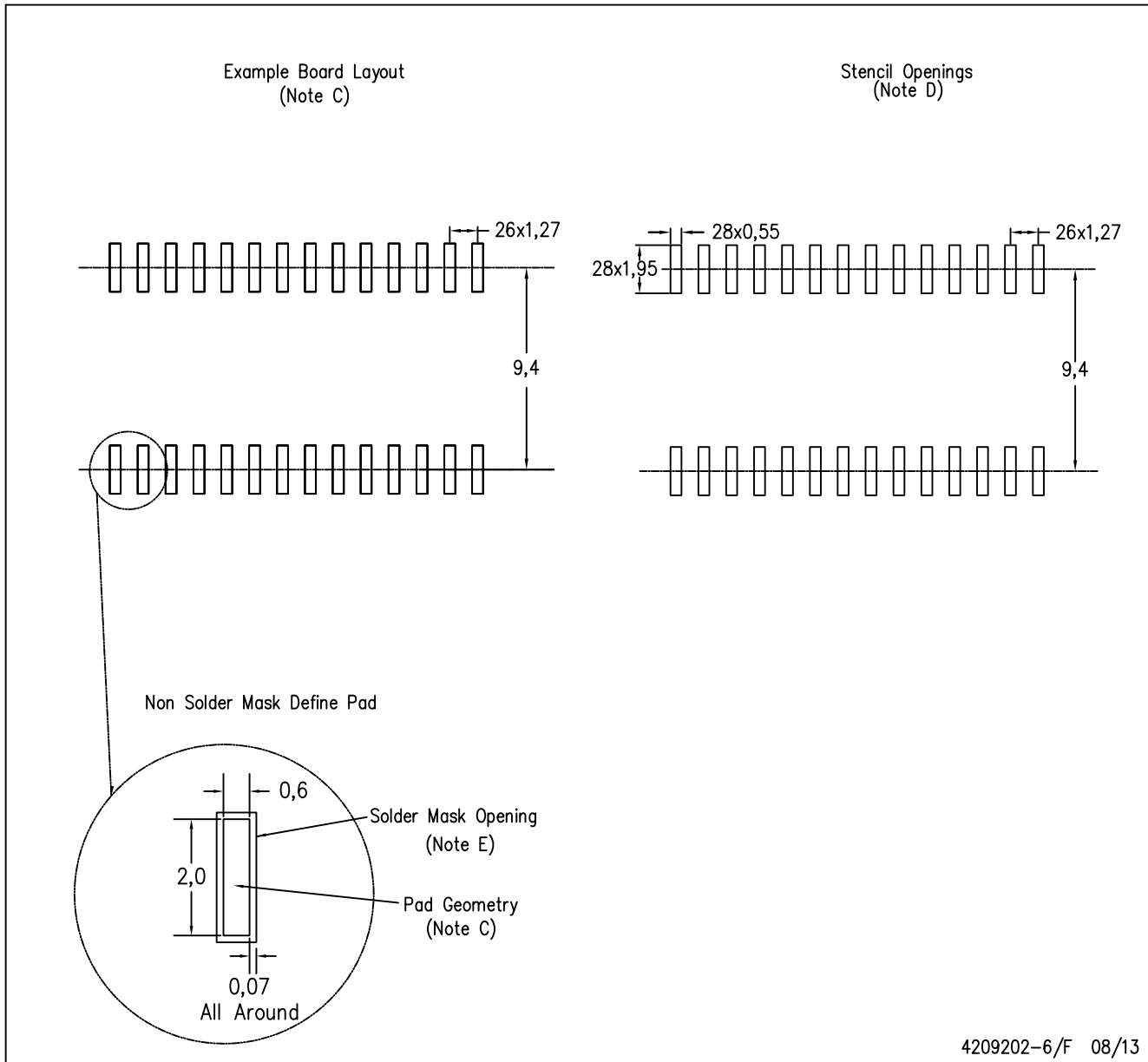

4209202-6/F 08/13

- NOTES:
- A. All linear dimensions are in millimeters.
 - B. This drawing is subject to change without notice.
 - C. Refer to IPC7351 for alternate board design.
 - D. Laser cutting apertures with trapezoidal walls and also rounding corners will offer better paste release. Customers should contact their board assembly site for stencil design recommendations. Refer to IPC-7525
 - E. Customers should contact their board fabrication site for solder mask tolerances between and around signal pads.

PW (R-PDSO-G28)

PLASTIC SMALL OUTLINE

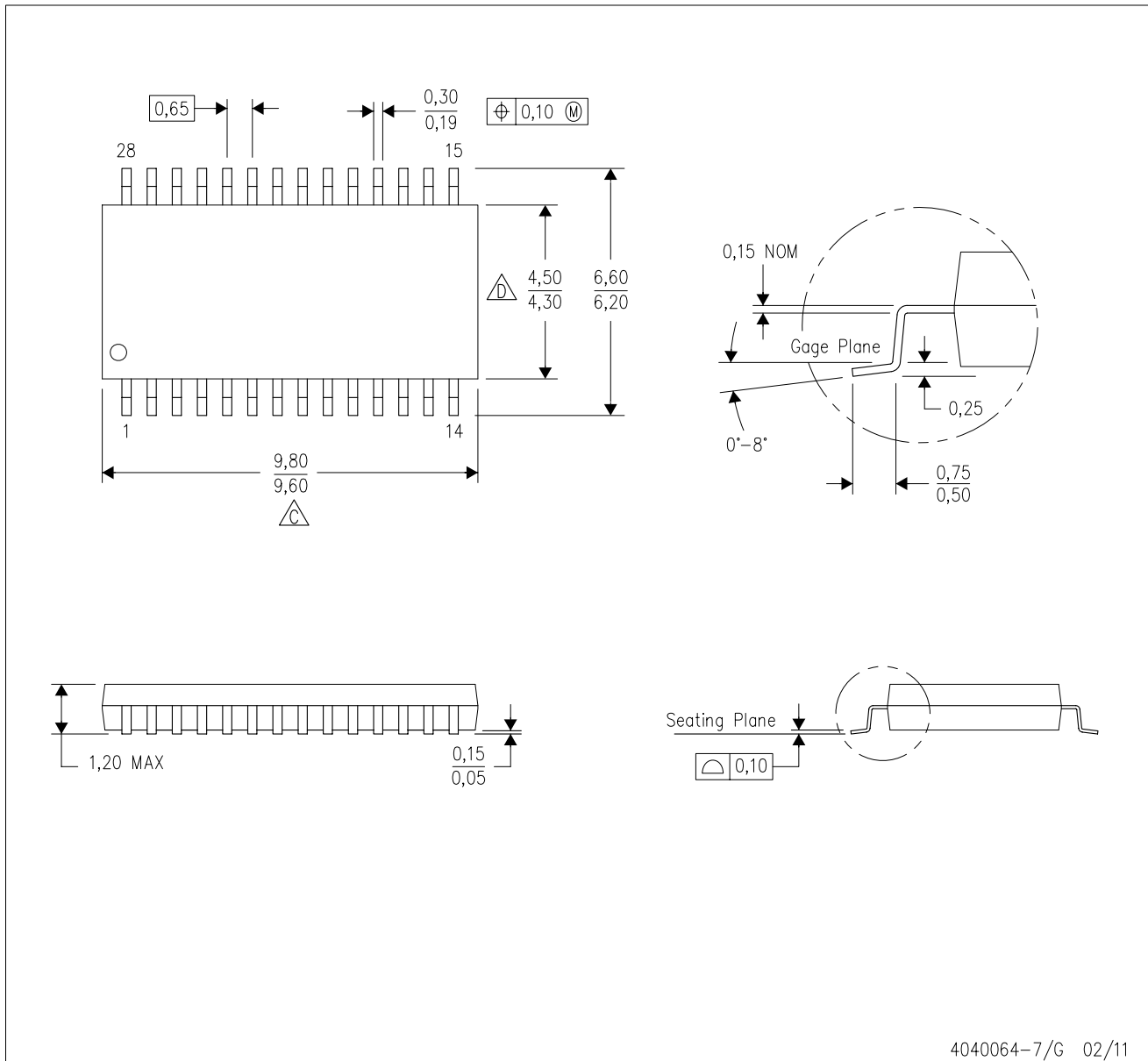

4040064-7/G 02/11

- NOTES:
- A. All linear dimensions are in millimeters. Dimensioning and tolerancing per ASME Y14.5M-1994.
 - B. This drawing is subject to change without notice.
 - C. Body length does not include mold flash, protrusions, or gate burrs. Mold flash, protrusions, or gate burrs shall not exceed 0,15 each side.
 - D. Body width does not include interlead flash. Interlead flash shall not exceed 0,25 each side.
 - E. Falls within JEDEC MO-153

PW (R-PDSO-G28)

PLASTIC SMALL OUTLINE

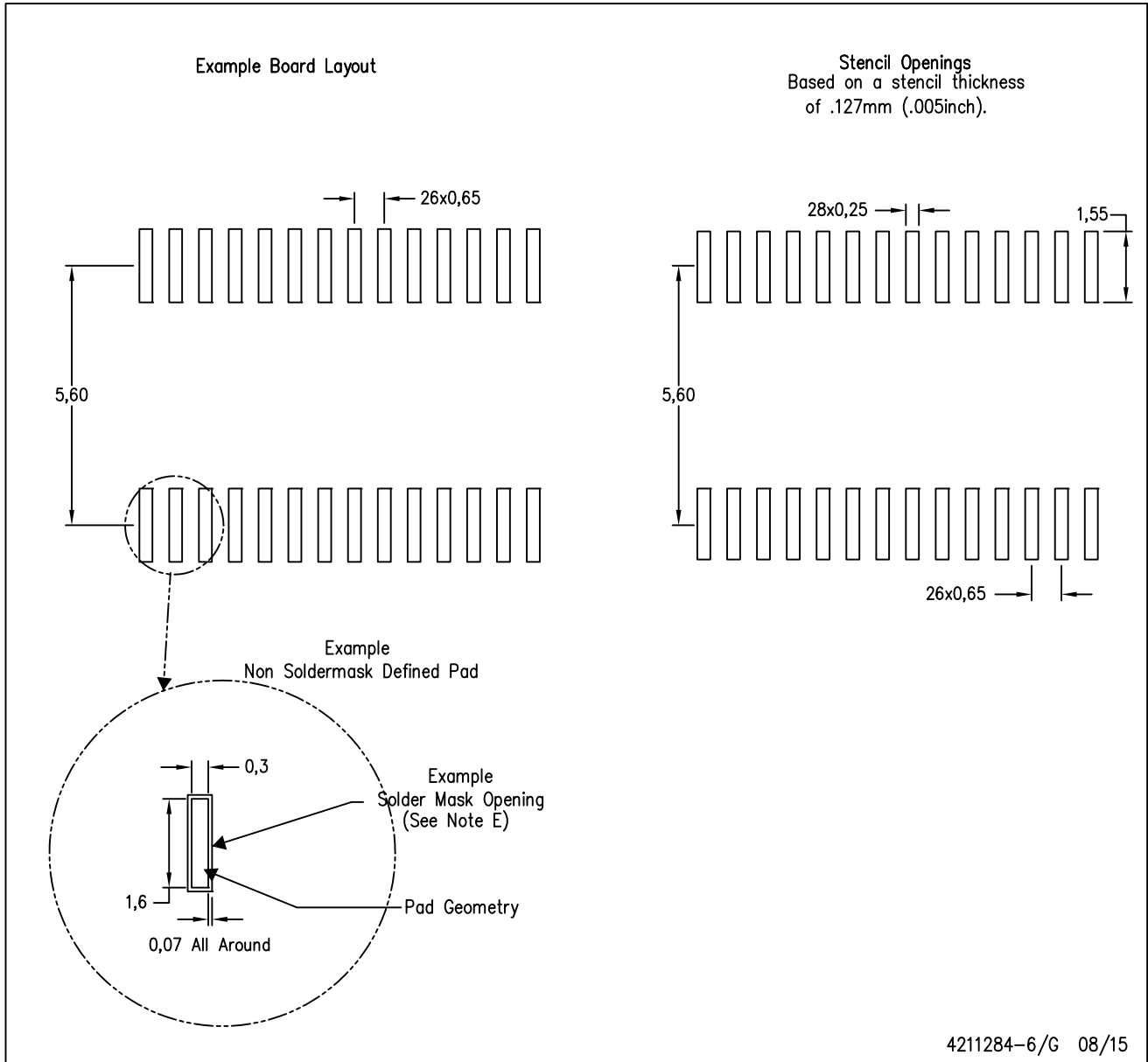

- NOTES:
- A. All linear dimensions are in millimeters.
 - B. This drawing is subject to change without notice.
 - C. Publication IPC-7351 is recommended for alternate design.
 - D. Laser cutting apertures with trapezoidal walls and also rounding corners will offer better paste release. Customers should contact their board assembly site for stencil design recommendations. Refer to IPC-7525 for other stencil recommendations.
 - E. Customers should contact their board fabrication site for solder mask tolerances between and around signal pads.

DB0028A

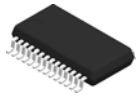

PACKAGE OUTLINE

SSOP - 2 mm max height

SMALL OUTLINE PACKAGE

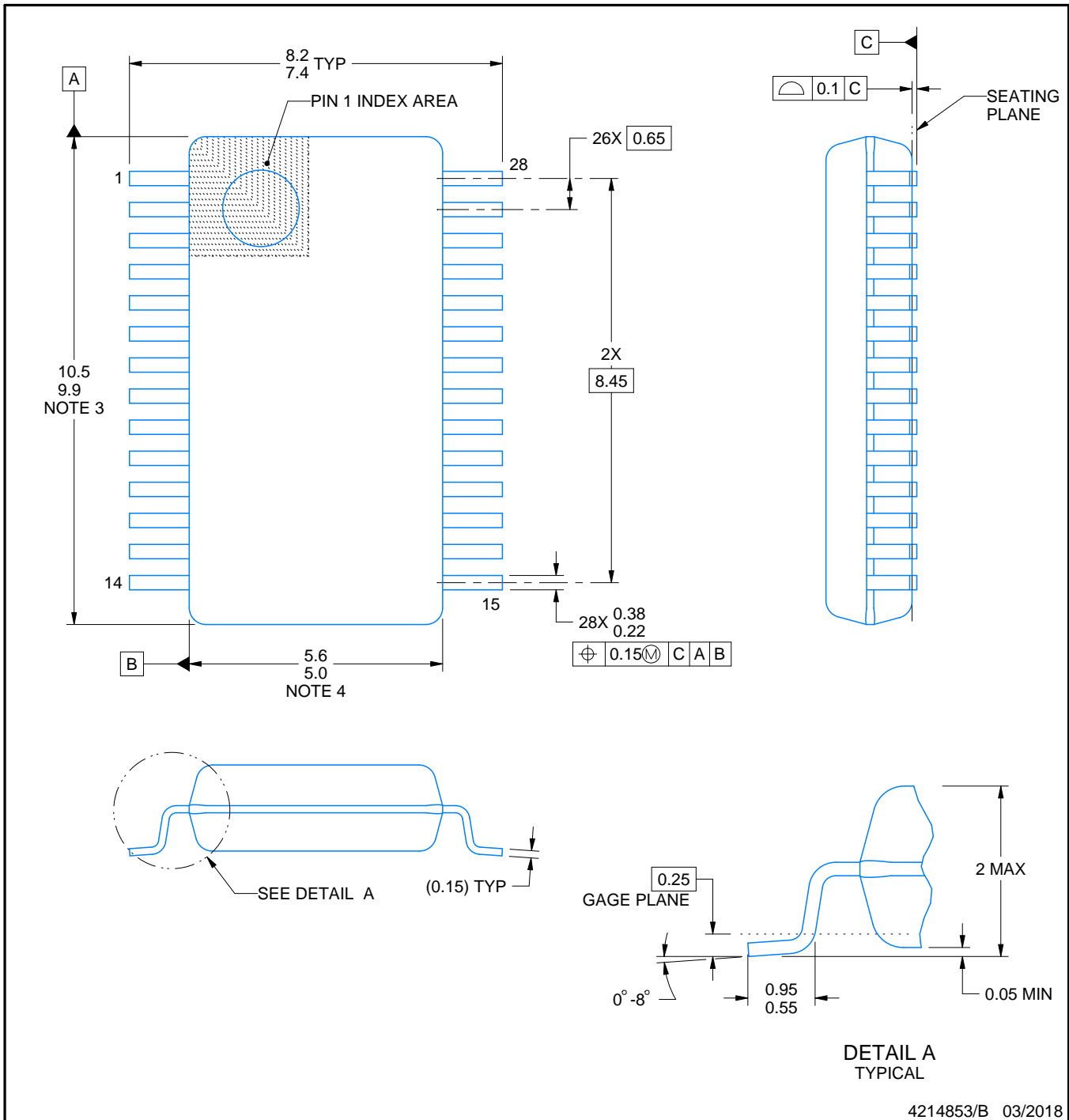

4214853/B 03/2018

NOTES:

1. All linear dimensions are in millimeters. Any dimensions in parenthesis are for reference only. Dimensioning and tolerancing per ASME Y14.5M.
2. This drawing is subject to change without notice.
3. This dimension does not include mold flash, protrusions, or gate burrs. Mold flash, protrusions, or gate burrs shall not exceed 0.15 mm per side.
4. This dimension does not include interlead flash. Interlead flash shall not exceed 0.25 mm per side.
5. Reference JEDEC registration MO-150.

EXAMPLE BOARD LAYOUT

DB0028A

SSOP - 2 mm max height

SMALL OUTLINE PACKAGE

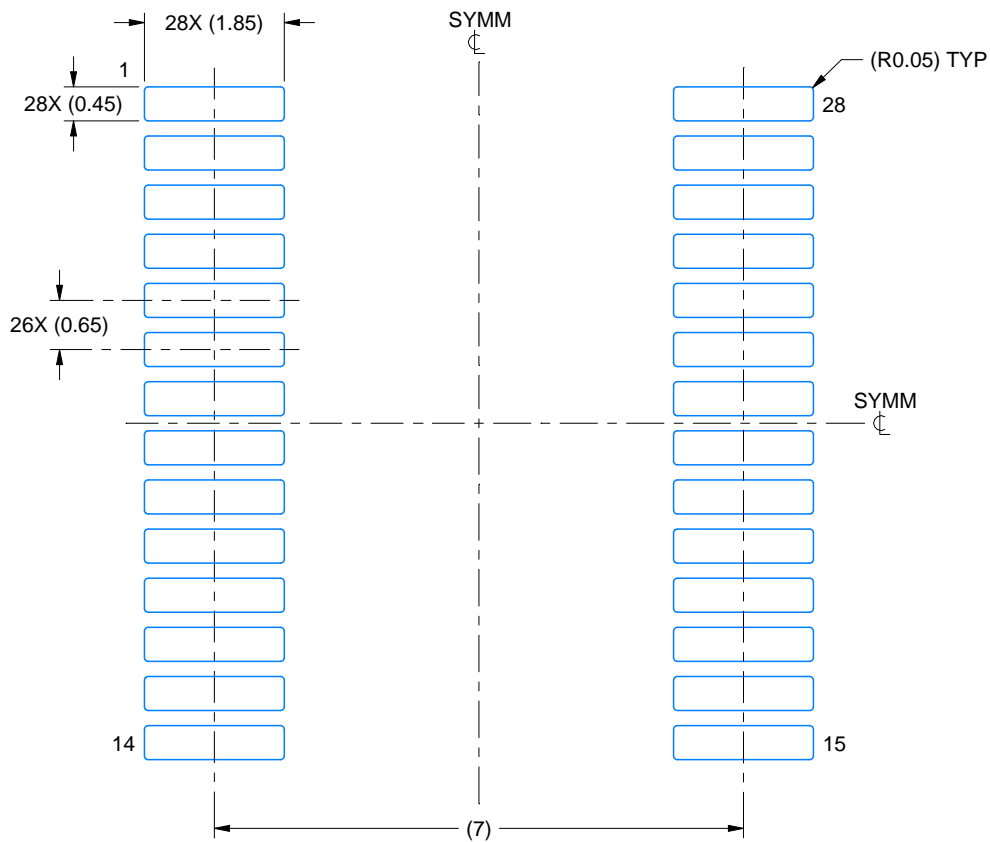

LAND PATTERN EXAMPLE
EXPOSED METAL SHOWN
SCALE: 10X

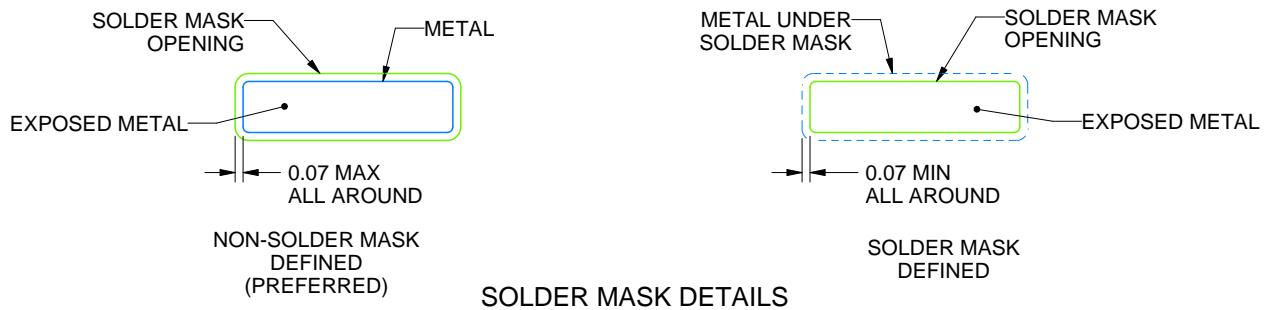

4214853/B 03/2018

NOTES: (continued)

- 6. Publication IPC-7351 may have alternate designs.
- 7. Solder mask tolerances between and around signal pads can vary based on board fabrication site.

EXAMPLE STENCIL DESIGN

DB0028A

SSOP - 2 mm max height

SMALL OUTLINE PACKAGE

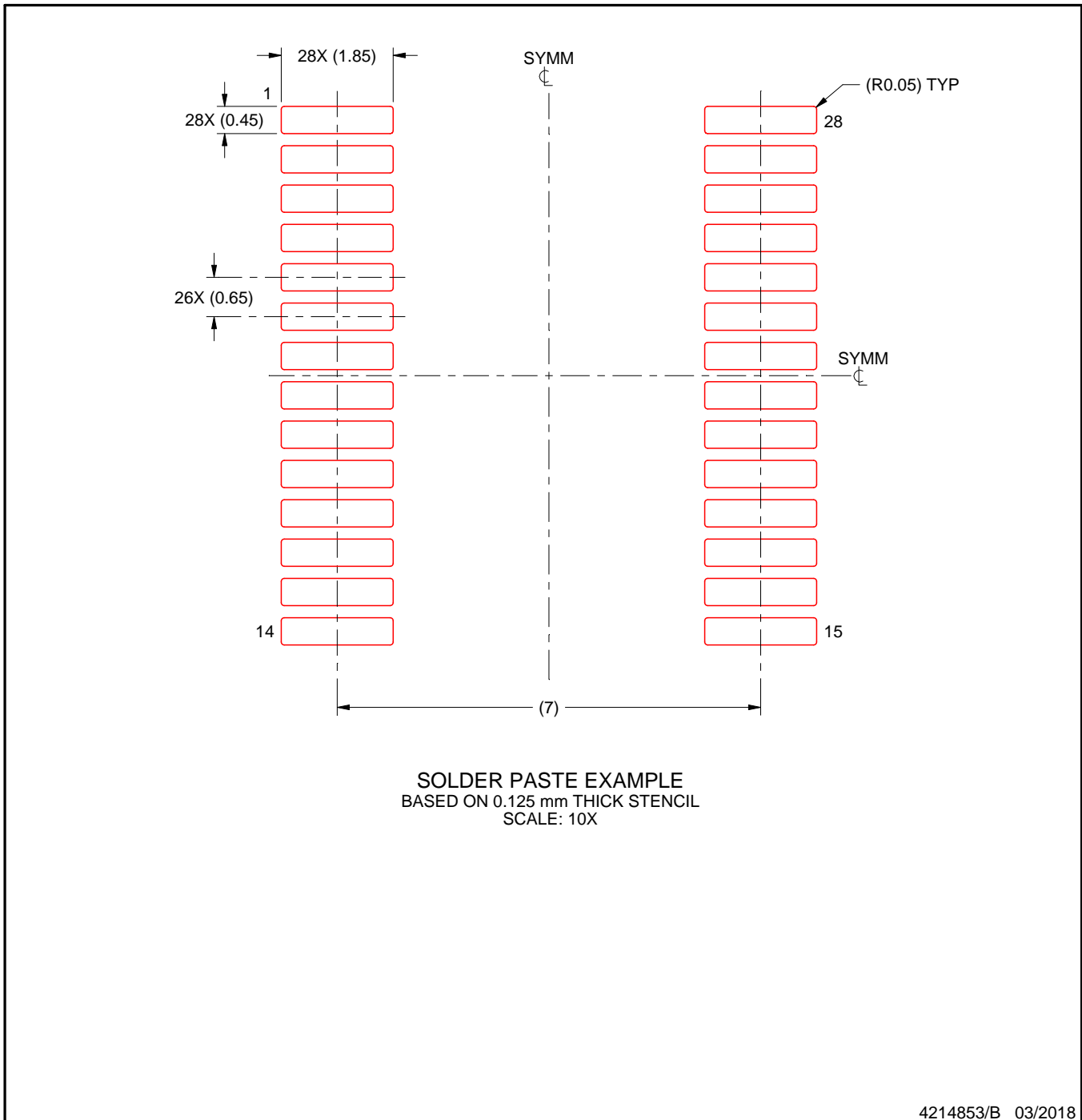

NOTES: (continued)

8. Laser cutting apertures with trapezoidal walls and rounded corners may offer better paste release. IPC-7525 may have alternate design recommendations.
9. Board assembly site may have different recommendations for stencil design.

IMPORTANT NOTICE AND DISCLAIMER

TI PROVIDES TECHNICAL AND RELIABILITY DATA (INCLUDING DATA SHEETS), DESIGN RESOURCES (INCLUDING REFERENCE DESIGNS), APPLICATION OR OTHER DESIGN ADVICE, WEB TOOLS, SAFETY INFORMATION, AND OTHER RESOURCES "AS IS" AND WITH ALL FAULTS, AND DISCLAIMS ALL WARRANTIES, EXPRESS AND IMPLIED, INCLUDING WITHOUT LIMITATION ANY IMPLIED WARRANTIES OF MERCHANTABILITY, FITNESS FOR A PARTICULAR PURPOSE OR NON-INFRINGEMENT OF THIRD PARTY INTELLECTUAL PROPERTY RIGHTS.

These resources are intended for skilled developers designing with TI products. You are solely responsible for (1) selecting the appropriate TI products for your application, (2) designing, validating and testing your application, and (3) ensuring your application meets applicable standards, and any other safety, security, regulatory or other requirements.

These resources are subject to change without notice. TI grants you permission to use these resources only for development of an application that uses the TI products described in the resource. Other reproduction and display of these resources is prohibited. No license is granted to any other TI intellectual property right or to any third party intellectual property right. TI disclaims responsibility for, and you will fully indemnify TI and its representatives against, any claims, damages, costs, losses, and liabilities arising out of your use of these resources.

TI's products are provided subject to [TI's Terms of Sale](#) or other applicable terms available either on [ti.com](https://www.ti.com) or provided in conjunction with such TI products. TI's provision of these resources does not expand or otherwise alter TI's applicable warranties or warranty disclaimers for TI products.

TI objects to and rejects any additional or different terms you may have proposed.

Mailing Address: Texas Instruments, Post Office Box 655303, Dallas, Texas 75265
Copyright © 2023, Texas Instruments Incorporated

Looking for pricing, stock, or lifecycle information?

Click below to explore more details on WIN SOURCE:

 [View MAX3243IPW](#) on WIN SOURCE

 [Texas Instruments](#) Information

Optimize Your Supply Chain with WIN SOURCE Solutions

-  Global Sourcing Solution
-  Obsolete Management
-  Cost Control Management
-  Shortage Management
-  Alternative Solution
-  Excess Inventory Management