



# Differential Microphone Preamplifier with Internal Bias and Complete Shutdown

## General Description

The MAX4063 is a differential-input microphone preamplifier optimized for high-performance, portable applications. The device features two selectable inputs, differential outputs, adjustable gain, an integrated low-noise bias source, and a low-power shutdown mode. Two input paths provide both differential and single-ended microphone sensing. The high-noise rejection of the differential input is ideally suited to an internal microphone where system noise and long-run PC board traces can degrade low-level signals. The single-ended input provides a simple connection to an external microphone.

The differential and single-ended inputs have independent, adjustable gains that are set with a single external resistor. Differential outputs provide a full-scale signal of up to 6V<sub>P-P</sub> from a single 3V supply, optimizing the dynamic range of the amplified signal. A complete shutdown mode reduces the supply current to only 0.3μA and disables the microphone bias for the ultimate in power savings.

The MAX4063 operates from 2.4V to 5.5V and is specified over the extended -40°C to +85°C operating temperature range. The MAX4063 is available in both 16-pin TQFN (4mm x 4mm x 0.8mm) and 14-pin TSSOP packages.

## Applications

Notebook Audio Systems  
Tablet PCs  
PDA Audio Systems  
Signal Conditioning

## Pin Configurations

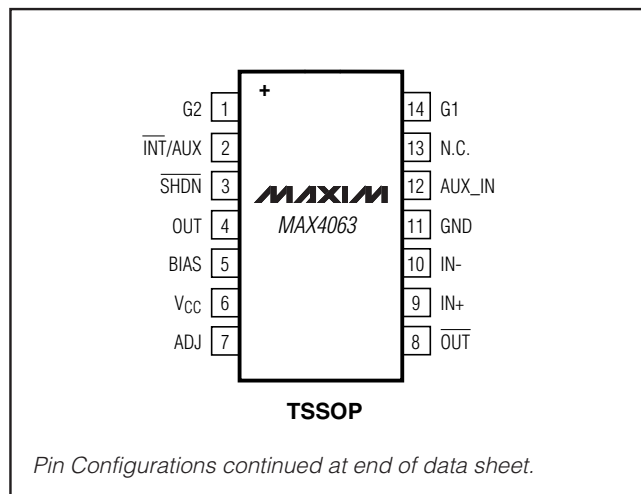

## Features

- ◆ 2.4V to 5.5V Single-Supply Operation
- ◆ Differential Inputs and Outputs
- ◆ Adjustable Gain
- ◆ High 95dB PSRR
- ◆ High 79dB CMRR
- ◆ Low-Noise, Integrated Microphone Bias
- ◆ 750μA Supply Current
- ◆ 0.3μA Shutdown Current
- ◆ ±4kV ESD Protection (AUX\_IN)
- ◆ THD+N: 0.05% at 1kHz
- ◆ Available in Space-Saving Packages
  - 14-Pin TSSOP
  - 16-Pin TQFN (4mm x 4mm x 0.8mm)

## Ordering Information

PART	TEMP RANGE	PIN-PACKAGE
MAX4063ETE+	-40°C to +85°C	16 TQFN-EP*
MAX4063EUD+	-40°C to +85°C	14 TSSOP

\*EP = Exposed pad.

+Denotes a lead(pB)-free/RoHS-compliant package.

## Typical Operating Circuit

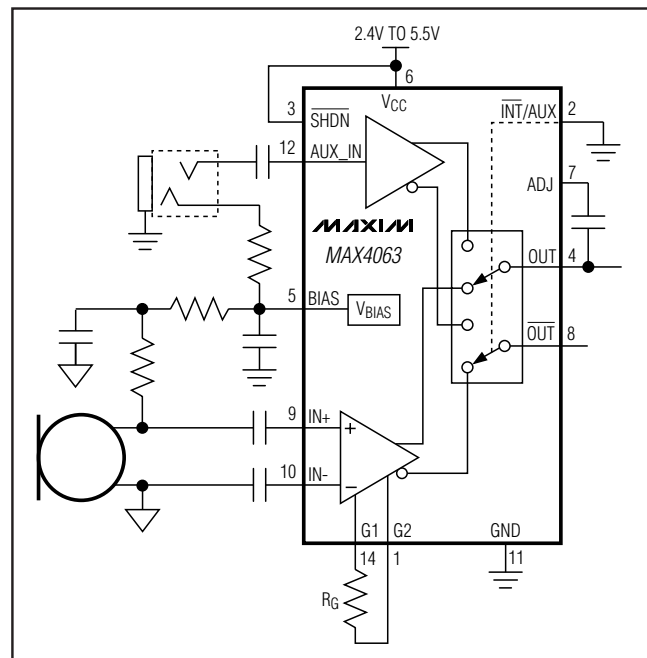

# Differential Microphone Preamplifier with Internal Bias and Complete Shutdown

## ABSOLUTE MAXIMUM RATINGS

Supply Voltage ( $V_{CC}$  to GND) .....-0.3V to +6V  
 Any Other Pin to GND .....-0.3V to ( $V_{CC} + 0.3V$ )  
 Duration of Short Circuit to GND or  $V_{CC}$  .....Continuous  
 Continuous Input Current (any pin) .....  $\pm 10mA$   
 Continuous Power Dissipation ( $T_A = +70^\circ C$ )  
 14-Pin TSSOP (derate 10.0mW/ $^\circ C$  above  $+70^\circ C$ ) .....796.8mW

16-Pin TQFN (derate 25.0mW/ $^\circ C$  above  $+70^\circ C$ ) .....2000mW  
 Operating Temperature Range .....-40 $^\circ C$  to +85 $^\circ C$   
 Storage Temperature Range .....-65 $^\circ C$  to +150 $^\circ C$   
 Lead Temperature (soldering, 10s) .....+300 $^\circ C$   
 Soldering Temperature (reflow) .....+260 $^\circ C$

Stresses beyond those listed under "Absolute Maximum Ratings" may cause permanent damage to the device. These are stress ratings only, and functional operation of the device at these or any other conditions beyond those indicated in the operational sections of the specifications is not implied. Exposure to absolute maximum rating conditions for extended periods may affect device reliability.

## ELECTRICAL CHARACTERISTICS

( $V_{CC} = 3V$ ,  $V_{GND} = 0V$ ,  $V_{SHDN} = V_{CC}$ ,  $V_{INT/AUX} = 0V$ ,  $R_G = 11.11k\Omega$ ,  $R_L = 100k\Omega$  to 1.5V,  $R_{BIAS} = \infty$ ,  $V_{OUT}$  is measured between OUT and  $\overline{OUT}$ .  $T_A = T_{MIN}$  to  $T_{MAX}$ , unless otherwise noted. Typical values are at  $T_A = +25^\circ C$ .) (Notes 1 and 2)

PARAMETER	SYMBOL	CONDITIONS	MIN	TYP	MAX	UNITS	
Supply Voltage Range	$V_{CC}$	Inferred from PSRR test	2.4		5.5	V	
Supply Current	$I_{CC}$			0.75	1.1	mA	
Output Common-Mode Voltage	$V_{OCM}$		1.25	1.5	1.75	V	
Slew Rate	SR	$A_V = 20V/V$		$\pm 1$		V/ $\mu s$	
Supply Current in Shutdown	$I_{SHDN}$	$V_{SHDN} = 0V$		0.001	1	$\mu A$	
Output Short-Circuit Current	ISC	To GND		30		mA	
		To $V_{CC}$		30			
<b>DIFFERENTIAL INPUT (<math>V_{INT/AUX} = 0V</math>)</b>							
Input Offset Voltage	$V_{OS}$	$T_A = +25^\circ C$		$\pm 1$		mV	
Common-Mode Input Voltage Range	$V_{CM}$	Inferred from CMRR test	1		2	V	
Maximum Differential Input Voltage	$V_{DIFFMAX}$	$A_V = 2V/V$		1		V	
Small-Signal Bandwidth	BW-3dB			600		kHz	
Input Resistance	$R_{IN}$	Either differential input		100		k $\Omega$	
Input Resistance Match	$R_{MATCH}$			1		%	
Input Noise-Voltage Density	$e_n$	$A_V = 20V/V$ , $f = 1kHz$		70		nV/ $\sqrt{Hz}$	
		$A_V = 200V/V$ , $f = 1kHz$		12			
RMS Output Noise Voltage	$V_{NRMS}$	$A_V = 20V/V$ , BW = 22Hz to 22kHz		225		$\mu V_{RMS}$	
Total Harmonic Distortion Plus Noise	THD+N	$A_V = 20V/V$ , $f = 1kHz$ , $V_{OUT} = 0.7V_{RMS}$ , BW = 22Hz to 22kHz		0.05		%	
Differential Gain	$A_{VDIFF}$	1V < $V_{CM}$ < 2V, $V_{OUT} = 0.7V_{RMS}$	$R_G = open$		2	V/V	
			$R_G = 11.11k\Omega$	19.2	20		20.8
			$R_G = 1.01k\Omega$		200		
Common-Mode Rejection Ratio	CMRR	$V_{CM} = 500mV_{P-P}$ , $f = 1kHz$		70		dB	
Power-Supply Rejection Ratio	PSRR	$T_A = +25^\circ C$		95		dB	
		$T_A = T_{MIN} - T_{MAX}$		85			
		$V_{CC} = 5V \pm 100mV$ , $f = 1kHz$		86			

# Differential Microphone Preamplifier with Internal Bias and Complete Shutdown

## ELECTRICAL CHARACTERISTICS (continued)

( $V_{CC} = 3V$ ,  $V_{GND} = 0V$ ,  $V_{SHDN} = V_{CC}$ ,  $V_{INT/AUX} = 0V$ ,  $R_G = 11.11k\Omega$ ,  $R_L = 100k\Omega$  to  $1.5V$ ,  $R_{BIAS} = \infty$ ,  $V_{OUT}$  is measured between  $\overline{OUT}$  and  $\overline{OUT}$ .  $T_A = T_{MIN}$  to  $T_{MAX}$ , unless otherwise noted. Typical values are at  $T_A = +25^\circ C$ .) (Notes 1 and 2)

PARAMETER	SYMBOL	CONDITIONS	MIN	TYP	MAX	UNITS
<b>AUXILIARY INPUT (<math>\overline{INT/AUX} = V_{CC}</math>)</b>						
Small-Signal Bandwidth	BW <sub>-3dB</sub>			230		kHz
Input Resistance	$R_{IN}$			100		k $\Omega$
Input Noise-Voltage Density	$e_n$	$f = 1kHz$		200		nV/ $\sqrt{Hz}$
RMS Output Noise Voltage	$V_{NRMS}$	BW = 22Hz to 22kHz		620		$\mu V_{RMS}$
Total Harmonic Distortion Plus Noise	THD+N	$f = 1kHz$ , BW = 22Hz to 22kHz		0.007		%
Power-Supply Rejection Ratio	PSRR	$T_A = +25^\circ C$	80	100		dB
		$T_A = T_{MIN} - T_{MAX}$	72			
Voltage Gain	$A_{VAUX}$	$V_{OUT} = 0.7V_{RMS}$	-19.5	-20	-20.5	V/V
<b>BIAS OUTPUT</b>						
Output Voltage	$V_{OUT}$	$I_{BIAS} = 0.5mA$ to GND	2	2.2		V
Output Resistance	$R_{OUT}$	$I_{BIAS} = 0.5mA$ to GND		16	30	$\Omega$
Output Noise Voltage	$V_{NRMS}$	$I_{BIAS} = 0.5mA$ to GND, BW = 22Hz to 22kHz		20		$\mu V_{RMS}$
Power-Supply Rejection Ratio	PSRR	$I_{BIAS} = 0.5mA$ to GND, $V_{CC} = 2.4V$ to $5.5V$	60	74		dB
		$I_{BIAS} = 0.5mA$ , $V_{CC} = 3V + 100mV_{P-P}$ , $f = 1kHz$		71		
<b>DIGITAL INPUTS (<math>\overline{SHDN}</math> and <math>\overline{INT/AUX}</math>)</b>						
Input Leakage Current	$I_{IN}$	$V_{IN} = 0V$ or $V_{CC}$			$\pm 1$	$\mu A$
Input Voltage High	$V_{INH}$		$0.7 \times V_{CC}$			V
Input Voltage Low	$V_{INL}$			$0.3 \times V_{CC}$		V
Shutdown Enable Time	$t_{ON}$			10		$\mu s$
Shutdown Disable Time	$t_{OFF}$			10		$\mu s$

**Note 1:** All specifications are 100% tested at  $T_A = +25^\circ C$ . Specification limits over temperature ( $T_A = T_{MIN}$  to  $T_{MAX}$ ) are guaranteed by design, not production tested.

**Note 2:** MAX4063 requires a  $1\mu F$  capacitor from BIAS to ground and a  $10pF$  capacitor from ADJ to  $\overline{OUT}$ .

# Differential Microphone Preamplifier with Internal Bias and Complete Shutdown

## Typical Operating Characteristics

( $V_{CC} = 3V$ ,  $A_V = 20V/V$ ,  $R_L \geq 100k\Omega$  to  $1.5V$ ,  $V_{SHDN} = V_{CC}$ ,  $V_{OUT}$  is measured between  $OUT$  and  $\overline{OUT}$ .  $T_A = +25^\circ C$ , unless otherwise noted.)

**GAIN vs. FREQUENCY (NO LOAD)**

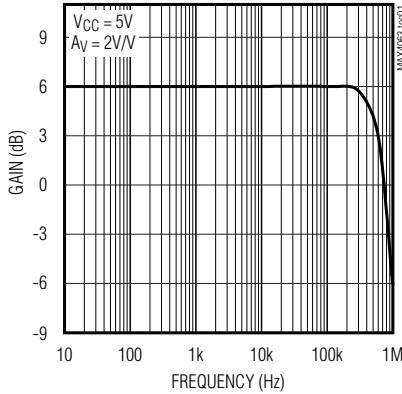

**POWER-SUPPLY REJECTION RATIO vs. FREQUENCY (DIFF INPUT)**

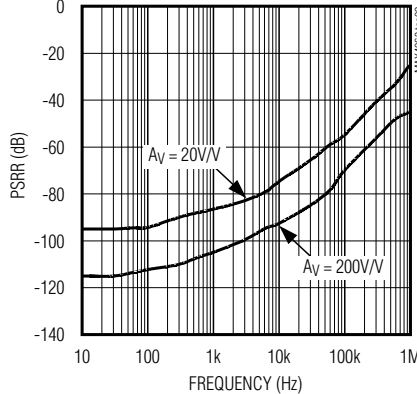

**SUPPLY CURRENT vs. TEMPERATURE**

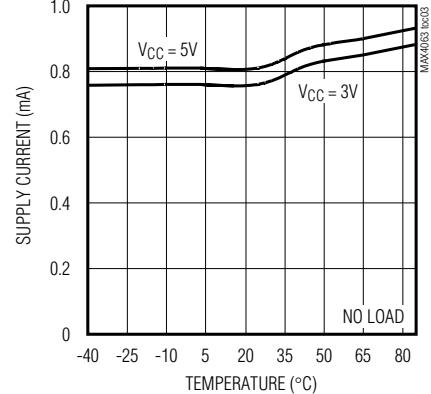

**SUPPLY CURRENT vs. SUPPLY VOLTAGE**

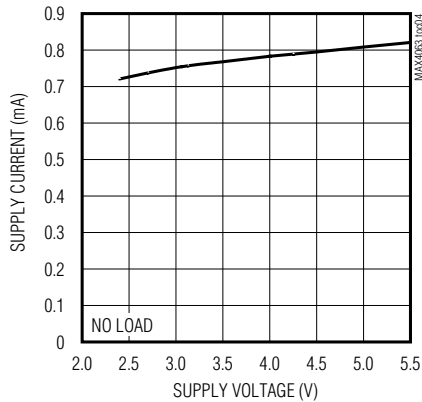

**SHUTDOWN SUPPLY CURRENT vs. TEMPERATURE**

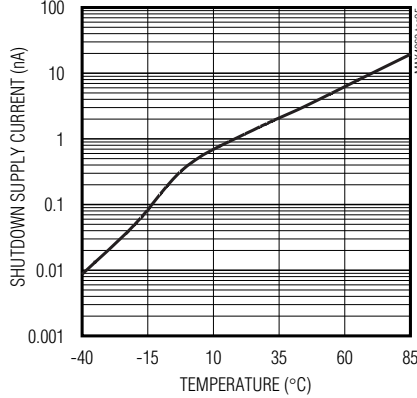

**V<sub>OH</sub> vs. TEMPERATURE**

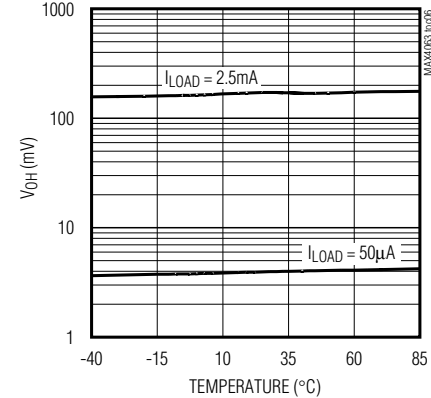

**V<sub>OL</sub> vs. TEMPERATURE**

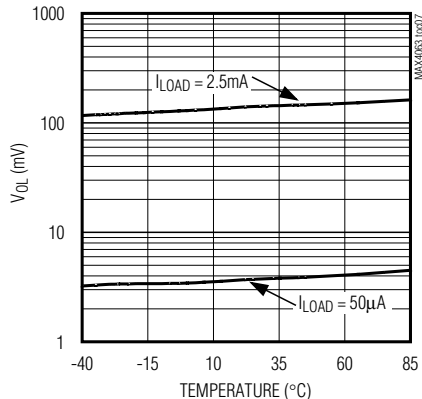

**V<sub>OH</sub> vs. LOAD CURRENT**

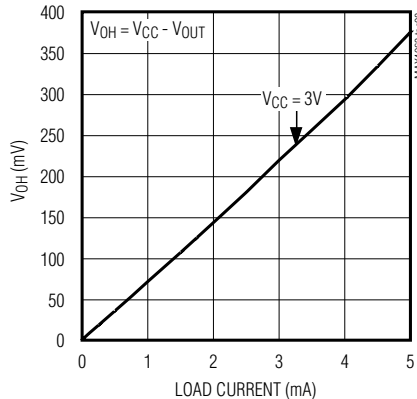

**V<sub>OL</sub> vs. LOAD CURRENT**

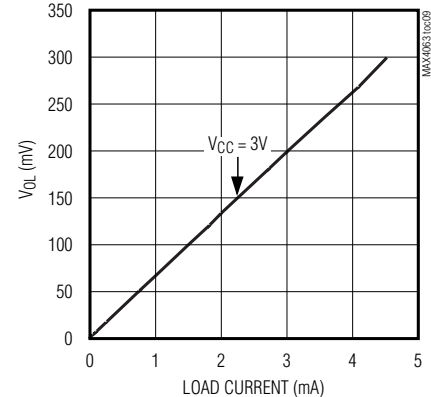

# Differential Microphone Preamplifier with Internal Bias and Complete Shutdown

MAX4063

## Typical Operating Characteristics (continued)

( $V_{CC} = 3V$ ,  $A_V = 20V/V$ ,  $R_L \geq 100k\Omega$  to 1.5V,  $V_{SHDN} = V_{CC}$ ,  $V_{OUT}$  is measured between  $OUT$  and  $\overline{OUT}$ .  $T_A = +25^\circ C$ , unless otherwise noted.)

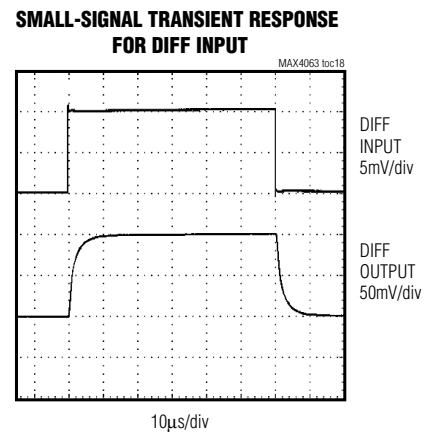
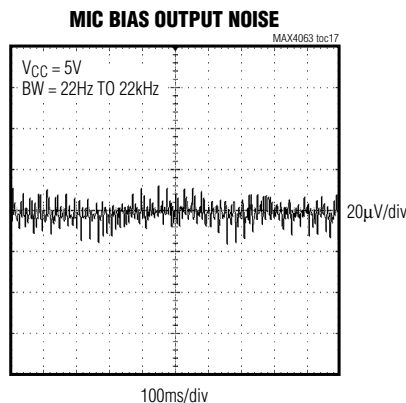
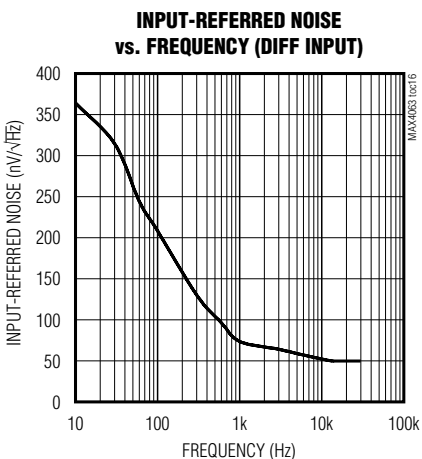
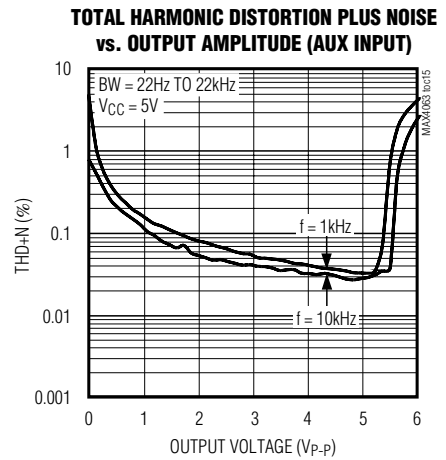
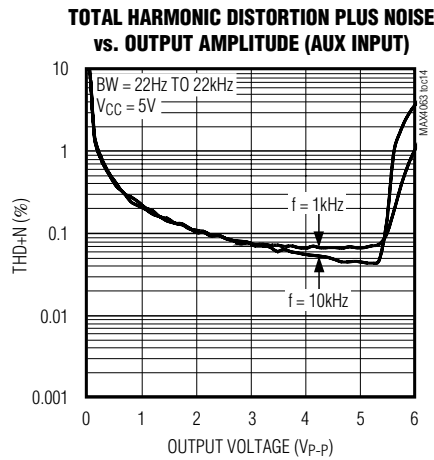
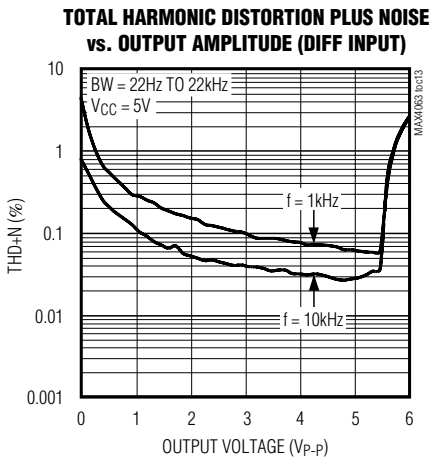
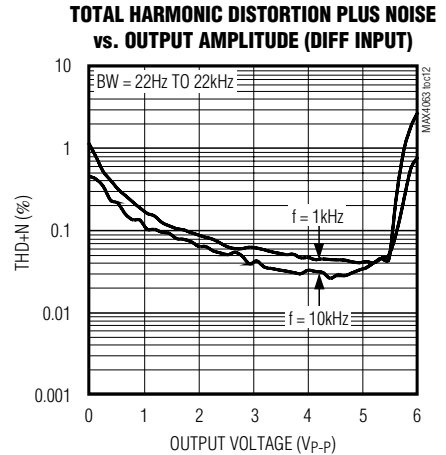
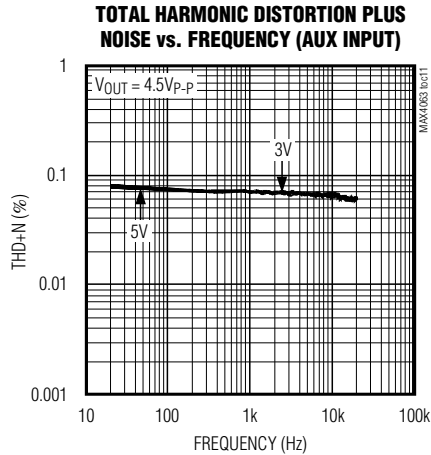
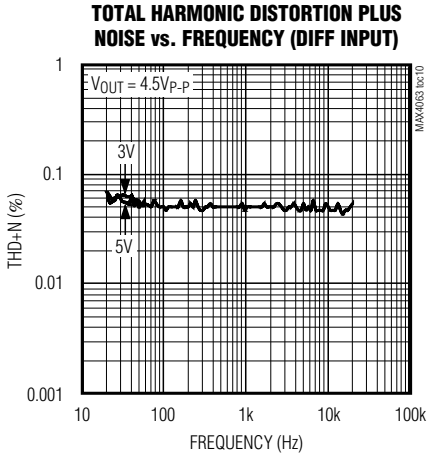

# Differential Microphone Preamplifier with Internal Bias and Complete Shutdown

## Typical Operating Characteristics (continued)

( $V_{CC} = 3V$ ,  $A_V = 20V/V$ ,  $R_L \geq 100k\Omega$  to 1.5V,  $V_{SHDN} = V_{CC}$ ,  $V_{OUT}$  is measured between  $OUT$  and  $\overline{OUT}$ .  $T_A = +25^\circ C$ , unless otherwise noted.)

**SMALL-SIGNAL TRANSIENT RESPONSE FOR AUX INPUT**

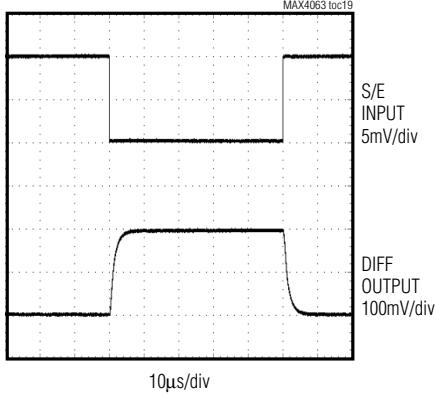

**LARGE-SIGNAL TRANSIENT RESPONSE FOR DIFF INPUT**

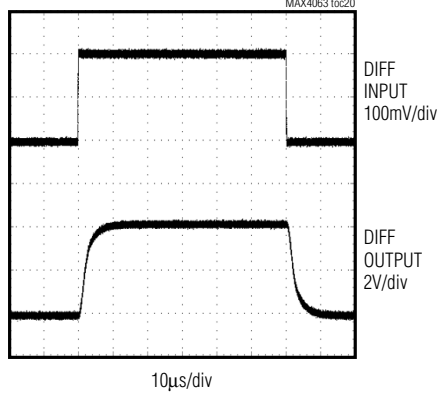

**LARGE-SIGNAL TRANSIENT RESPONSE FOR AUX INPUT**

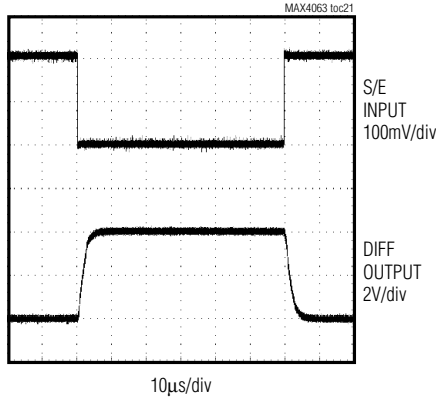

**OUTPUT OVERDRIVEN**

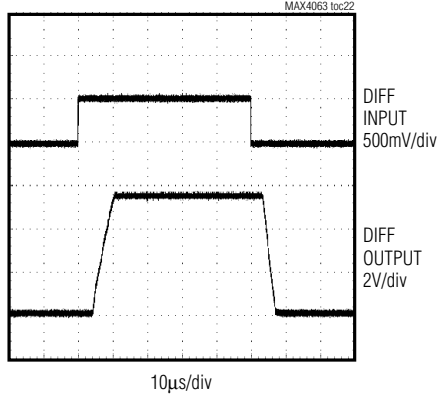

# Differential Microphone Preamplifier with Internal Bias and Complete Shutdown

MAX4063

## Pin Description

PIN		NAME	FUNCTION
TSSOP	TQFN		
1	15	G2	Gain-Selectable Input. Connect an external resistor between G1 and G2 to set the gain for the differential amplifier (see <i>Adjustable Differential Gain-Setting</i> section).
2	16	$\overline{\text{INT/AUX}}$	Internal (Differential) or Auxiliary (Single-Ended) Input Select. Drive $\overline{\text{INT/AUX}}$ low to select differential in or high to select auxiliary in.
3	1	$\overline{\text{SHDN}}$	Shutdown Input. Drive $\overline{\text{SHDN}}$ high for normal operation. Drive $\overline{\text{SHDN}}$ low for shutdown mode.
4	2	OUT	Amplifier Output. OUT is high impedance when in shutdown mode.
5	3	BIAS	External Electret Microphone Capsule Bias Output. Bypass BIAS with a 1 $\mu$ F capacitor to ground.
6	4	V <sub>CC</sub>	Power Supply. Bypass the V <sub>CC</sub> to GND with a 0.1 $\mu$ F capacitor.
7	5	ADJ	Adjustable Gain Select for AUX_IN (see <i>Auxiliary Input-Gain Adjustment</i> section). Connect a 10pF capacitor between OUT and ADJ.
8	7	$\overline{\text{OUT}}$	Complementary Amplifier Output. $\overline{\text{OUT}}$ is high impedance in shutdown mode.
9	9	IN+	Noninverting Differential Amplifier Input. AC-couple the audio signal into IN+.
10	10	IN-	Inverting Differential Amplifier Input. AC-couple the audio signal into IN-.
11	11	GND	Ground
12	12	AUX_IN	Single-Ended Input for Auxiliary Microphone. AC-couple the audio signal into AUX_IN.
13	6, 8, 14	N.C.	No Connection. Not internally connected.
14	13	G1	Gain-Selectable Input. Connect an external resistor between G1 and G2 to set the gain for the differential amplifier.
—	—	EP	Exposed Pad (TQFN Only). Internally connected to GND. Connect to a large ground plane to maximize thermal performance. Not intended as an electrical connection point.

## Detailed Description

The MAX4063 is a differential microphone preamplifier providing high-quality amplification, optimized for use in computer and mobile applications. This device features adjustable gain, very high power-supply rejection (95dB), and common-mode rejection (79dB), making it ideal for low-noise applications. The MAX4063 provides a differential input stage, making the device particularly effective when layout constraints force the microphone amplifier to be physically remote from the ECM microphone.

The MAX4063 is capable of switching its output between the differential input and an inverting single-ended input.  $\overline{\text{INT/AUX}}$  selects either the differential input or single-ended auxiliary input. In addition, the MAX4063 has an integrated microphone bias source, simplifying system design and eliminating the need for

external components. The MAX4063 has a complementary output allowing CODECs and other devices with differential inputs to be optimally driven (see *Functional Diagram*). The MAX4063 includes a 0.3 $\mu$ A shutdown mode for ultimate power savings. The differential gain of the MAX4063 is set with a single resistor connected between the G1 and G2 pins. The MAX4063 has an internal default gain of 20V/V on the AUX\_IN input. The AUX\_IN gain can be increased with a single external resistor (see the *Differential-Gain Adjustment and Auxiliary Input-Gain Adjustment* sections).

### Differential Input

The main microphone amplifier is a low-noise, differential input structure. This is an almost essential element when faced with amplification of low-amplitude analog signals in digitally intense environments such as note-

# Differential Microphone Preamp with Internal Bias and Complete Shutdown

## Functional Diagram

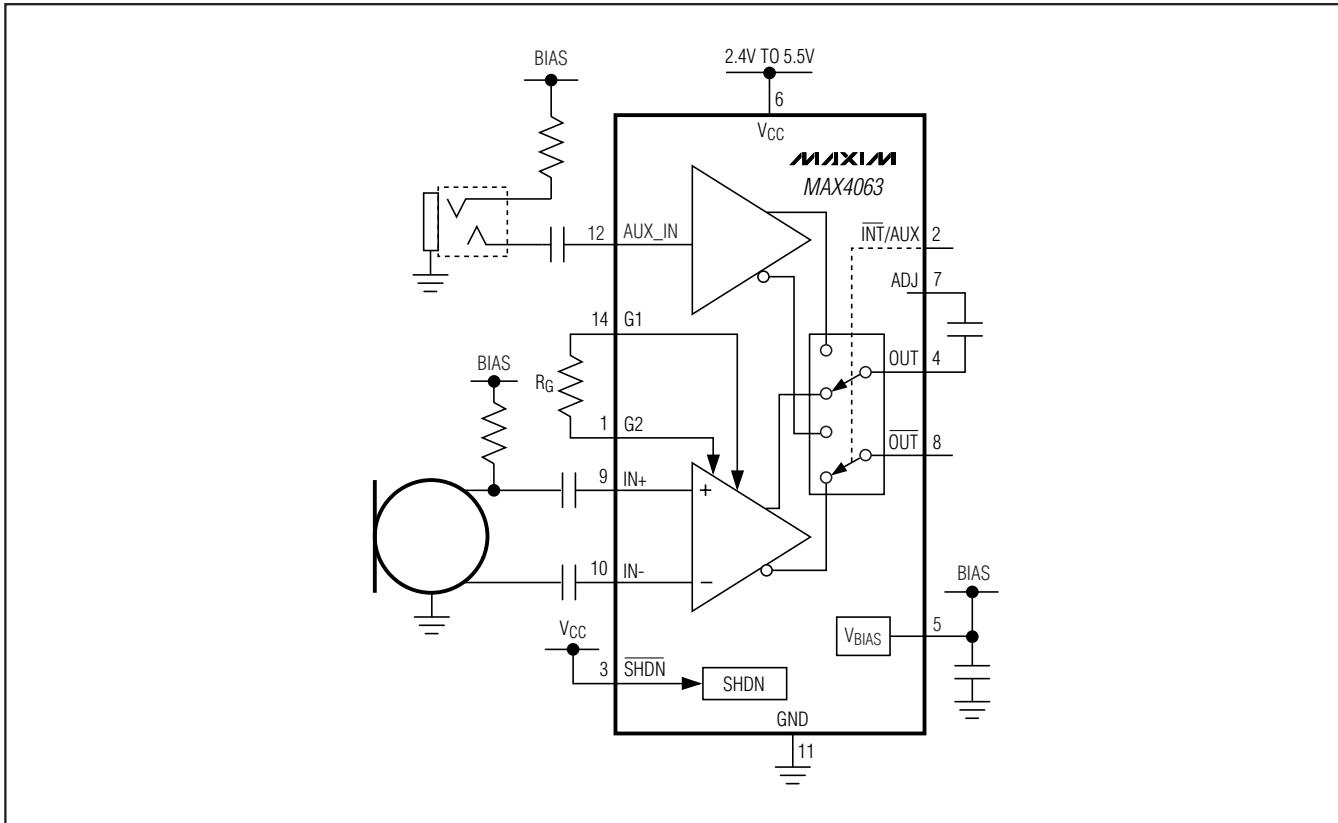

book PCs or PDAs. Used correctly, the advantages over a single-ended solution are:

- Better power-supply noise rejection.
- Less degradation from noise in PC board ground planes.
- The microphone and preamplifier may be placed physically further apart, easing PC board layout restrictions.

### Differential-Gain Adjustment

The MAX4063 allows the user to alter the differential gain to optimize the signal-to-noise ratio (SNR) of their system. The gain is set by a single external resistor ( $R_G$ ) connected between the G1 and G2 pins:

$$R_G = \frac{200k\Omega}{A_{VD} - 2}$$

where  $A_V$  is the required voltage gain.

Hence, an 11.11k $\Omega$  resistor yields a gain of 20V/V, or 26dB. Leaving the pins unconnected results in a gain of 2V/V. Gain is defined as:

For differential out:

$$A_{VD} = \frac{V_{OUT+} - V_{OUT-}}{V_{IN+} - V_{IN-}}$$

The resistor can be either fixed or variable, allowing the use of a digitally controlled potentiometer to alter the gain under software control.

### Auxiliary Input-Gain Adjustment

The MAX4063 provides an option to increase the AUX\_IN (see Figure 3). To increase the gain, connect resistor  $R_{ADJ}$  between the ADJ and AUX\_IN pins.  $R_{ADJ}$  is calculated from the following formula:

$$R_{ADJ} = \frac{2M\Omega}{A_{V_{AUX}} - 20} \text{ (to increase the gain)}$$

# Differential Microphone Preamplifier with Internal Bias and Complete Shutdown

MAX4063

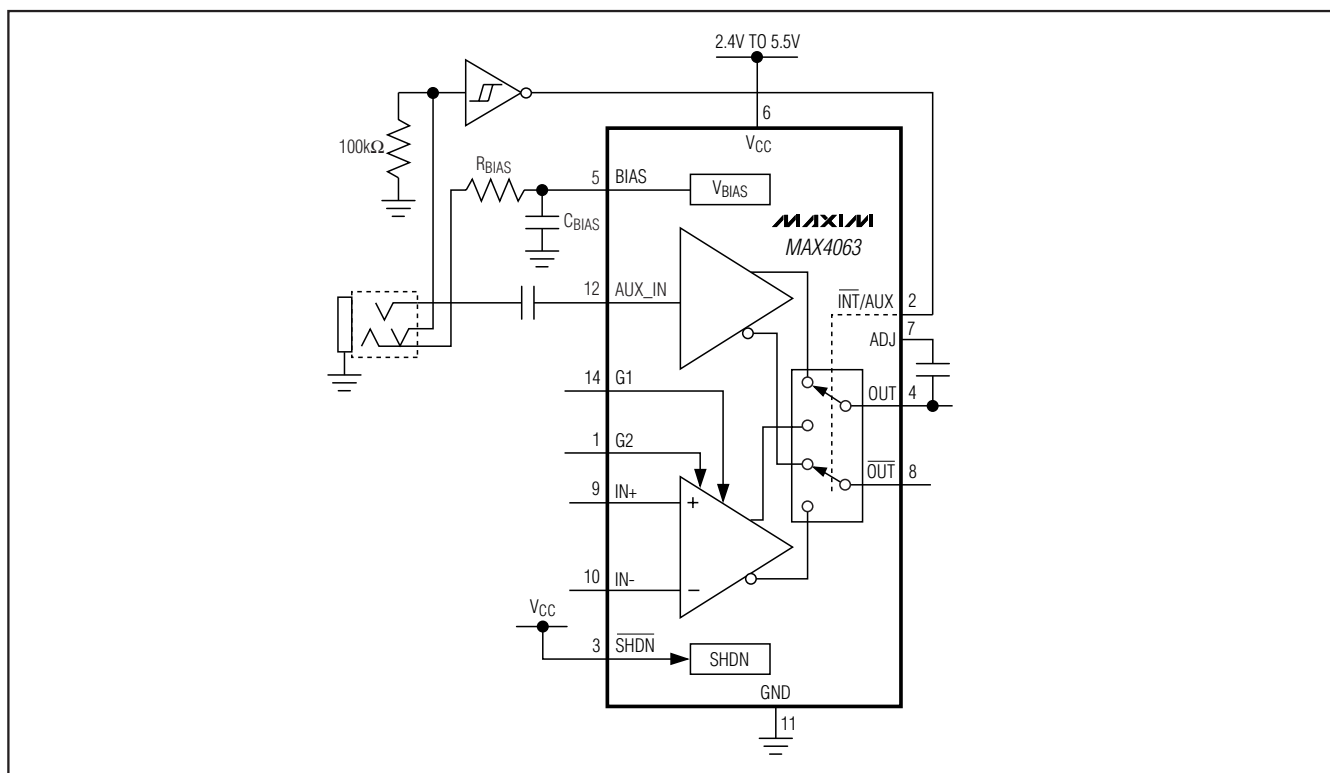

Figure 1. MAX4063 with Auxiliary Input Configuration

where:

$$AV_{AUX} = \frac{V_{OUT} - \overline{V_{OUT}}}{V_{AUX\_IN}}$$

$R_{ADJ}$  is placed between AUX\_IN and ADJ.

## Input Capacitors

The two differential microphone inputs and the single-ended auxiliary input of the MAX4063 have on-chip bias components, allowing the user to AC-couple any signals into the input. The input resistance is 100kΩ (typ), so the capacitor size may be chosen accordingly to define the LF rolloff desired. This can be calculated as:

$$C_{IN} = 1 / (2\pi f_{CUT} R_{IN})$$

This assumes a low source impedance is driving the inputs.

A further consideration for the differential input is the effect of these series input capacitors on low-frequency, common-mode rejection. Any mismatch in the values of these two capacitors degrades the CMRR at frequencies where the impedance of the capacitor is significant

compared to the input resistance of the amplifier—this is usually most noticeable at low frequencies. One way to avoid the need for matched or tight tolerance capacitors is to deliberately oversize the values on the differential inputs and to set the lower 3dB point ( $f_{CUT}$ ) of the amplifier by sizing the output capacitor appropriately.

The input impedance matching on the differential input is typically 1%, allowing input capacitor matching to be effective at improving low-frequency PSRR.

## Common-Mode Rejection Ratio

The common-mode rejection ratio (CMRR) refers to the amount of rejection that the amplifier is capable of providing to any signal applied equally to the IN+ and IN- inputs. In the case of amplifying low-level microphone signals in noisy digital environments, it is a key figure of merit. In audio circuits, this is generally measured for  $V_{IN}$  as an AC signal:

$$CMRR(dB) = A_{DM} / A_{CM}$$

where  $A_{DM}$  is the differential gain,  $A_{CM}$  is the common-mode gain.

Input voltages should be sufficiently small such that the output is not clipped in either differential or common-

# Differential Microphone Preamp with Internal Bias and Complete Shutdown

mode application. The topology used in the MAX4063 means that the CMRR actually improves at higher differential gains—another advantage of using differential sensing.

## Auxiliary Input

The auxiliary input is a single-ended input intended to be used with a jack-socket type microphone input (Figure 1). Internal DC-bias components (as on the main inputs) allow the input signal to be AC-coupled. Mechanically switched jack sockets can be used in conjunction with the  $\overline{\text{INT/AUX}}$  select pin, allowing the auxiliary microphone input to be automatically selected when a jack socket is inserted.

## Microphone Bias Voltage

On the MAX4063 thin QFN package, connect the exposed paddle (backside of PRS) to the ground plane. The MAX4063 has an integrated low-noise, low-output impedance bias voltage. An optimum electret bias resistor can be set externally. This gives a low-noise, flexible solution that can run from 2.4V to 5.5V, which is suitable for hand-held devices such as PDAs that typically have audio power supplies in the 3V region (Figure 2).

## Output

### DC Bias

In shutdown mode, the bias voltage is disabled.  $\text{OUT}$  and  $\overline{\text{OUT}}$  have a low-noise, DC-bias voltage independent of the power supplies, resulting in superior PSRR performance. The MAX4063 outputs are high impedance when the part is in shutdown mode.

### Differential Output

The MAX4063 features a differential output stage ( $\text{OUT}$  and  $\overline{\text{OUT}}$ ), allowing optimum performance when connected to ADCs and CODECs with differential inputs. This differential output is particularly useful in designs where the microphone preamplifier is mounted some distance away from the CODEC/ADC, as the low-impedance, differential line provides excellent noise rejection and immunity (Figure 4).

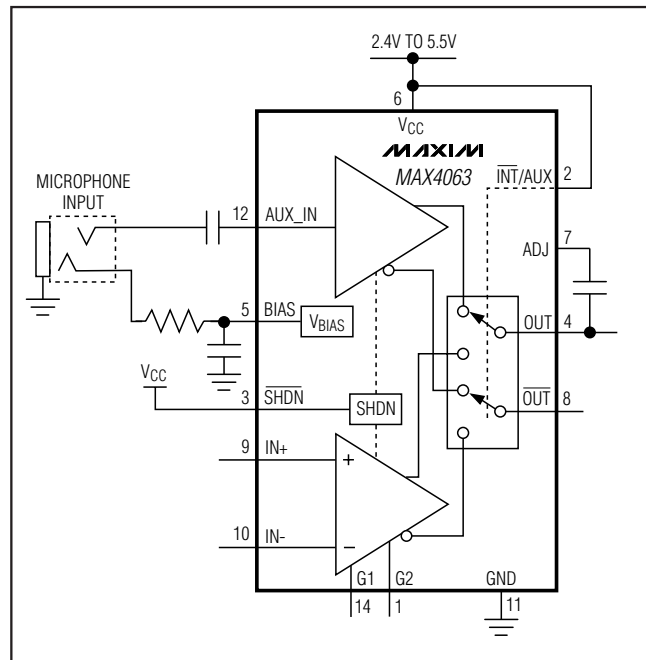

Figure 2. MAX4063 Used for Biasing a Microphone

## Applications Information

### Shutdown Mode

The MAX4063 features a low-power, complete shutdown mode. When  $\overline{\text{SHDN}}$  goes low, the supply current drops to  $0.3\mu\text{A}$ , the output enters a high-impedance state, and the bias current to the microphone is switched off. Driving  $\overline{\text{SHDN}}$  high enables the amplifier.  $\overline{\text{SHDN}}$  should not be left unconnected.

### Power Supplies and Layout

The MAX4063 operates from a 2.4V to 5.5V single supply. Bypass the power supply with a  $0.1\mu\text{F}$  capacitor to ground. In systems where analog and digital grounds are available, the MAX4063 should be connected to the analog ground.

# Differential Microphone Preamplifier with Internal Bias and Complete Shutdown

MAX4063

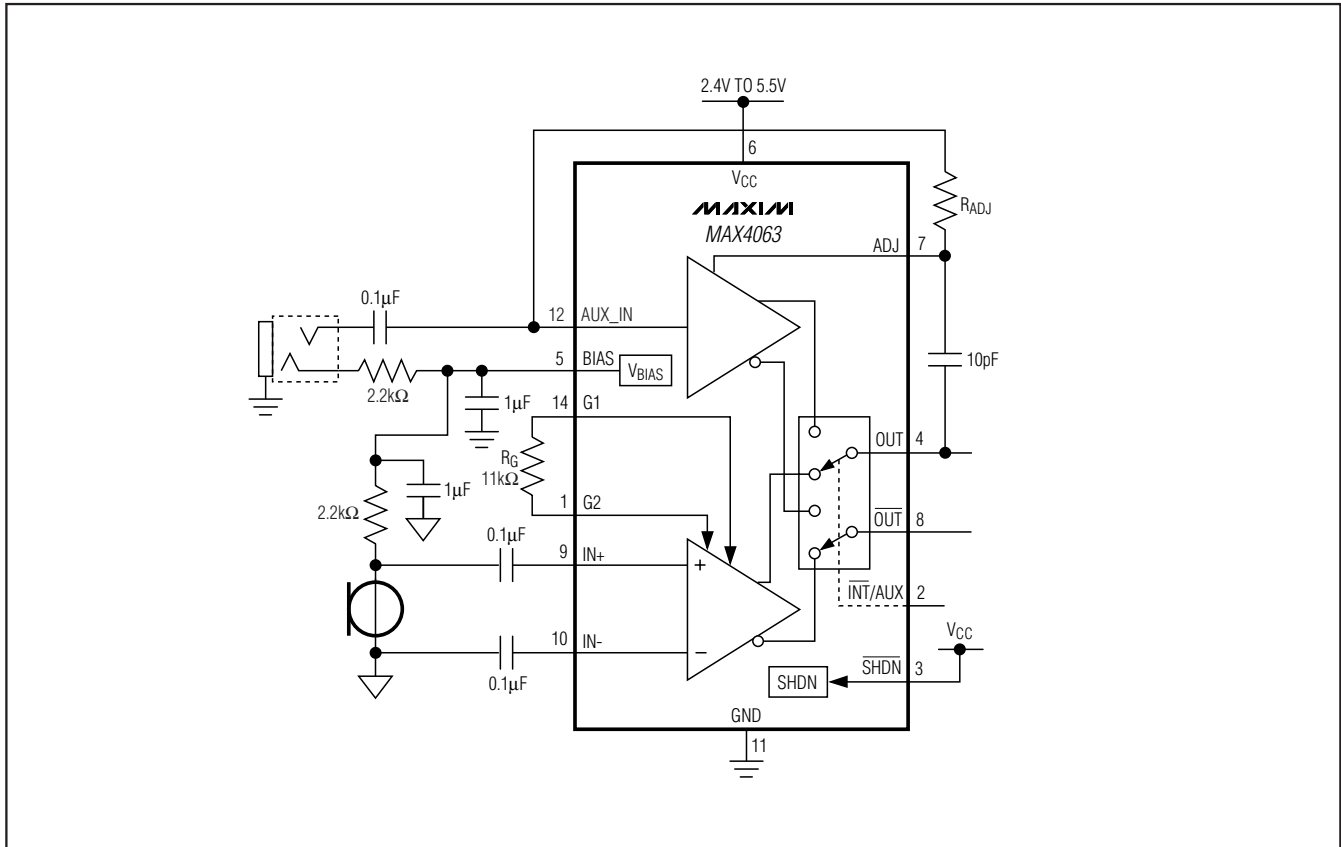

Figure 3. MAX4063 Used to Bias a Microphone Connected to the Auxiliary Input and the Differential Input

# Differential Microphone Preamplifier with Internal Bias and Complete Shutdown

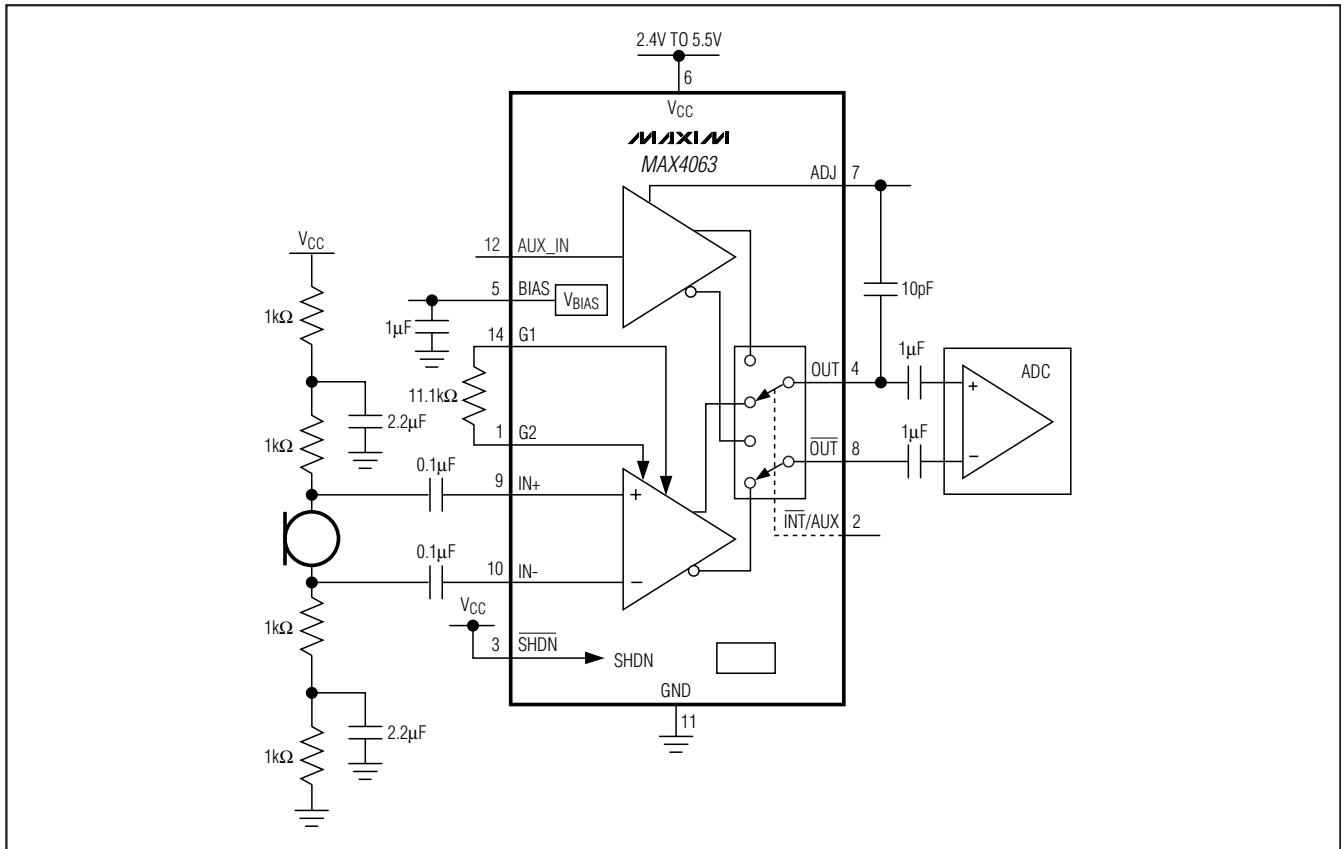
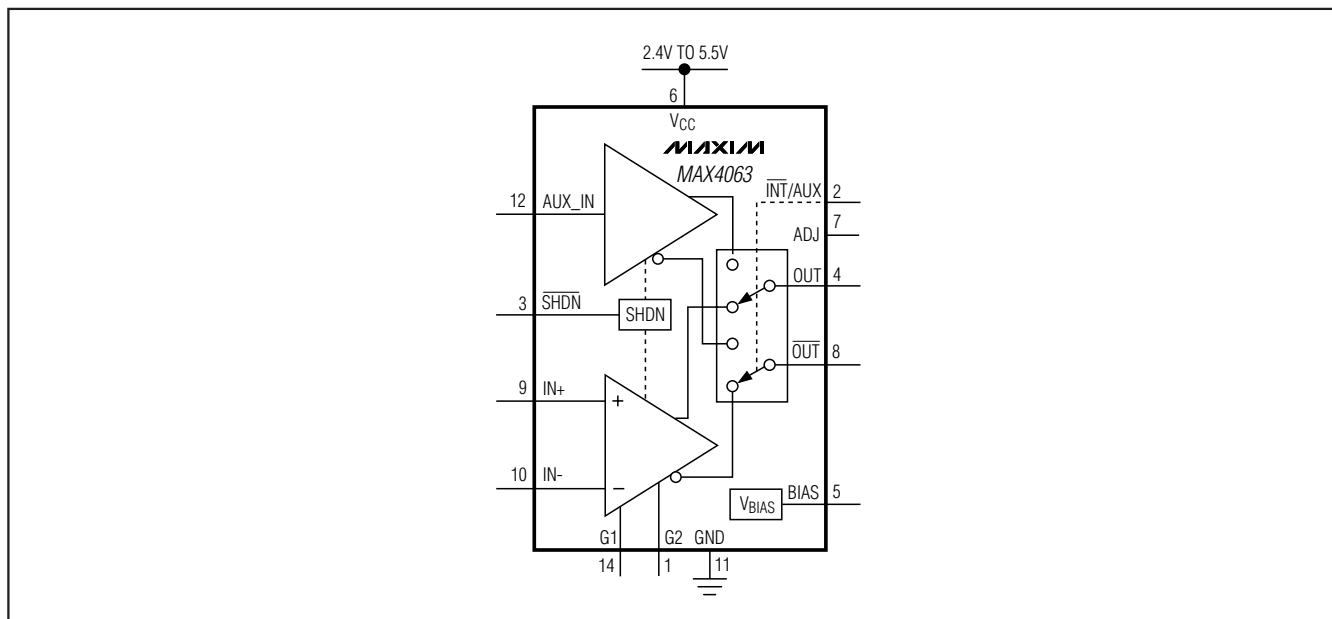

Figure 4. Using the MAX4063 with Differential Input/Differential Output Configuration

# Differential Microphone Preamplifier with Internal Bias and Complete Shutdown

## Simplified Block Diagram

**MAX4063**



## Chip Information

PROCESS: BiCMOS

## Pin Configurations (continued)

### Package Information

For the latest package outline information and land patterns (footprints), go to [www.maxim-ic.com/packages](http://www.maxim-ic.com/packages). Note that a "+", "#", or "-" in the package code indicates RoHS status only. Package drawings may show a different suffix character, but the drawing pertains to the package regardless of RoHS status.

PACKAGE TYPE	PACKAGE CODE	OUTLINE NO.	LAND PATTERN NO.
14 SSOP	U14+1	<a href="#">21-0066</a>	<a href="#">90-0113</a>
16 TQFN	T1644+4	<a href="#">21-0139</a>	<a href="#">90-0070</a>

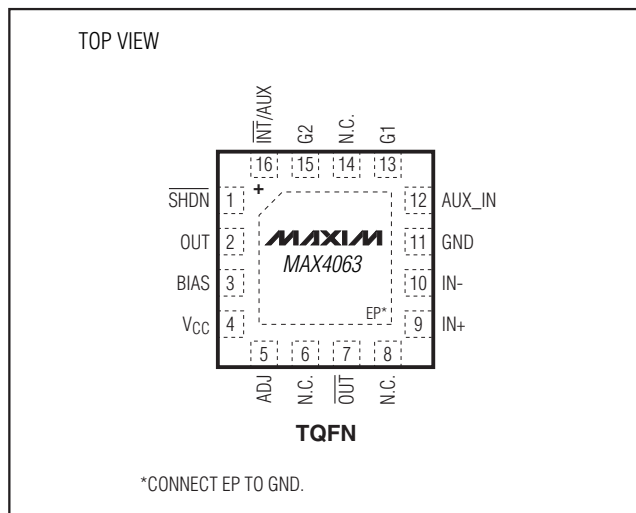

# **Differential Microphone Preamplifier with Internal Bias and Complete Shutdown**

## **Revision History**



<b>REVISION NUMBER</b>	<b>REVISION DATE</b>	<b>DESCRIPTION</b>	<b>PAGES CHANGED</b>
0	1/03	Initial release	—
1	6/11	Added EP information to <i>Pin Description</i> , updated power dissipation ratings, updated <i>Ordering Information</i> and <i>Pin Configuration</i> for lead-free parts	1, 2, 7, 13

Maxim cannot assume responsibility for use of any circuitry other than circuitry entirely embodied in a Maxim product. No circuit patent licenses are implied. Maxim reserves the right to change the circuitry and specifications without notice at any time.

14 **Maxim Integrated Products, 120 San Gabriel Drive, Sunnyvale, CA 94086 408-737-7600**

## Looking for pricing, stock, or lifecycle information?

Click below to explore more details on WIN SOURCE:

-  [View MAX4063ETE+T on WIN SOURCE](#)
-  [Maxim Integrated Information](#)

## Optimize Your Supply Chain with WIN SOURCE Solutions

-  Global Sourcing Solution
-  Obsolete Management
-  Cost Control Management
-  Shortage Management
-  Alternative Solution
-  Excess Inventory Management