



**THE DATASHEET OF
MAX5021EUT+T**



Current-Mode PWM Controllers for Isolated Power Supplies

General Description

The MAX5021/MAX5022 current-mode PWM controllers contain all the control circuitry required for the design of wide input voltage range isolated power supplies. These devices are well suited for use in universal input (85VAC to 265VAC) off-line or telecom (-36VDC to -72VDC) power supplies.

An undervoltage lockout (UVLO) circuit with large hysteresis coupled with low startup and operating current reduce power dissipation in the startup resistor and allow use of ceramic bypass capacitors. The 262kHz switching frequency is internally trimmed to $\pm 12\%$ accuracy; this allows the optimization of the magnetic and filter components resulting in compact, cost-effective power supplies. The MAX5021 with 50% maximum duty cycle and MAX5022 with 75% maximum duty cycle are recommended for forward converters and fly-back converters, respectively. The MAX5021/MAX5022 are available in 6-pin SOT23, 8-pin μ MAX, and 8-pin DIP packages and are rated for operation over the -40°C to $+85^{\circ}\text{C}$ temperature range.

Applications

- Universal Off-Line Power Supplies
- Standby Power Supplies
- Isolated Power Supplies
- Isolated Telecom Power Supplies
- Mobile Phone Chargers

Features

- ◆ Available in a Tiny 6-Pin SOT23 Package
- ◆ 50 μ A Typical Startup Current
- ◆ 1.2mA Typical Operating Current
- ◆ Large UVLO Hysteresis of 14V
- ◆ Fixed Switching Frequency of 262kHz $\pm 12\%$
- ◆ 50% Maximum Duty Cycle Limit (MAX5021)
- ◆ 75% Maximum Duty Cycle Limit (MAX5022)
- ◆ 60ns Cycle-by-Cycle Current-Limit Response Time

Ordering Information

PART	MAX DUTY CYCLE	TEMP. RANGE	PIN-PACKAGE	TOP MARK
MAX5021EUT	50%	-40°C to $+85^{\circ}\text{C}$	6 SOT23-6	AASQ
MAX5021EUA	50%	-40°C to $+85^{\circ}\text{C}$	8 μ MAX	—
MAX5021EPA	50%	-40°C to $+85^{\circ}\text{C}$	8 PDIP	—
MAX5022EUT	75%	-40°C to $+85^{\circ}\text{C}$	6 SOT23-6	AASR
MAX5022EUA	75%	-40°C to $+85^{\circ}\text{C}$	8 μ MAX	—
MAX5022EPA	75%	-40°C to $+85^{\circ}\text{C}$	8 PDIP	—

WARNING: The MAX5021/MAX5022 are designed to work with high voltages. Exercise caution!

Typical Operating Circuit

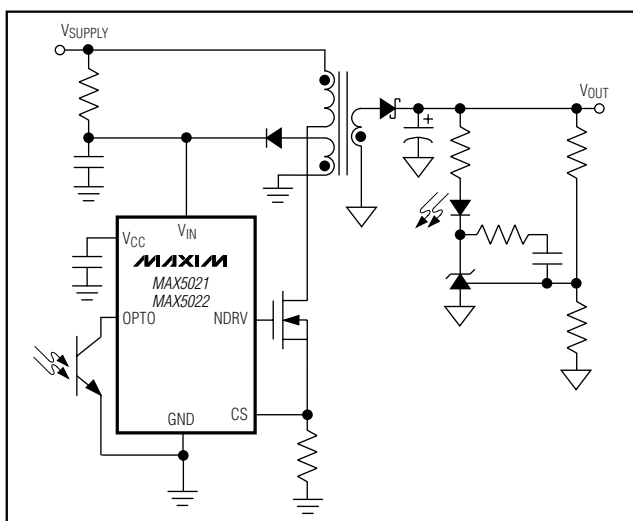

Pin Configuration

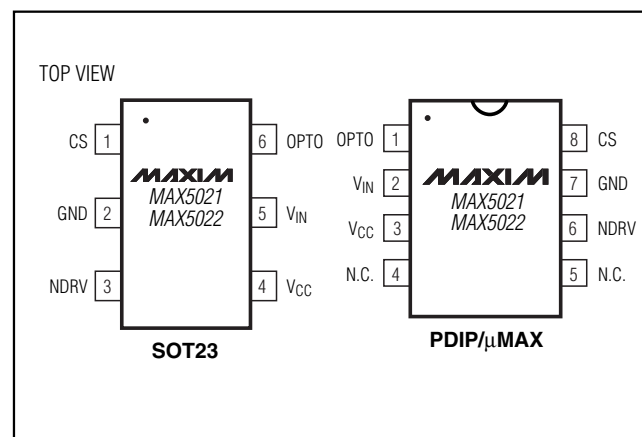

Current-Mode PWM Controllers for Isolated Power Supplies

ABSOLUTE MAXIMUM RATINGS

V_{IN} to GND	-0.3V to +30V	8-Pin μ MAX (derate 4.5mW/°C above +70°C)	362mW
V_{CC} to GND	-0.3V to +13V	8-Pin PDIP (derate 9.1mW/°C above +70°C)	727mW
NDRV to GND	-0.3V to ($V_{CC} + 0.3V$)	Operating Temperature Range	-40°C to +85°C
CS, OPTO to GND	-0.3V to +6V	Storage Temperature Range	-55°C to +150°C
NDRV Short-Circuit to GND	Continuous	Lead Temperature (soldering 10s)	+300°C
Continuous Power Dissipation ($T_A = +70^\circ\text{C}$)			
6-Pin SOT23 (derate 8.7mW/°C above +70°C)	696mW		

Stresses beyond those listed under "Absolute Maximum Ratings" may cause permanent damage to the device. These are stress ratings only, and functional operation of the device at these or any other conditions beyond those indicated in the operational sections of the specifications is not implied. Exposure to absolute maximum rating conditions for extended periods may affect device reliability.

ELECTRICAL CHARACTERISTICS

($V_{IN} = +11V$ to +28V, $V_{CS} = 0$, OPTO is unconnected, 10nF bypass capacitors at V_{IN} and V_{CC} , NDRV unconnected, $T_A = -40^\circ\text{C}$ to +85°C, unless otherwise noted. Typical values are at $V_{IN} = +12V$, $T_A = +25^\circ\text{C}$, unless otherwise noted.) (Note 1)

PARAMETER	SYMBOL	CONDITIONS	MIN	TYP	MAX	UNITS
UNDERVOLTAGE LOCKOUT/STARTUP						
Undervoltage Lockout Wakeup Level	V_{UVR}	V_{IN} rising	22	24	26	V
Undervoltage Lockout Shutdown Level	V_{UVF}	V_{IN} falling	9.3	10	10.9	V
V_{IN} Supply Current at Startup	I_{START}	$V_{IN} = +22V$		50	85	μA
V_{IN} Range	V_{IN}		11		28	V
Undervoltage Lockout Propagation Delay	T_{UVR}	V_{IN} steps up from +9V to +26V		5		μs
	T_{UVF}	V_{IN} steps down from +26V to +9V		1		
INTERNAL SUPPLY						
V_{CC} Regulator Set Point	V_{CCSP}	$V_{IN} = +11V$ to +28V, sourcing 1 μA to 5mA from V_{CC}	7.0		10.5	V
V_{IN} Supply Current after Startup	I_{IN}	$V_{IN} = +28V$, OPTO connected to GND	0.9		2.43	mA
		$V_{IN} = +28V$, OPTO unconnected (Note 2)	0.4			
GATE DRIVER						
Driver Output Impedance	$R_{ON(LOW)}$	Measured at NDRV sinking 5mA		10	20	Ω
	$R_{ON(HIGH)}$	Measured at NDRV sourcing 5mA		20	40	
Driver Peak Sink Current	I_{SINK}			250		mA
Driver Peak Source Current	I_{SOURCE}			150		mA
PWM COMPARATOR						
Comparator Offset Voltage	V_{OPWM}	$V_{OPTO} - V_{CS}$	600	750	900	mV
CS Input Bias Current	I_{CS}		-2		+2	μA
Propagation Delay from Comparator Input to NDRV	T_{PWM}	25mV overdrive		60		ns
Minimum On-Time	$T_{ON(MIN)}$			150		ns
CURRENT-LIMIT COMPARATOR						
Current-Limit Trip Threshold	V_{CS}		540	600	660	mV
Current-Limit Propagation Delay from Comparator Input to NDRV	T_{CL}	25mV overdrive		60		ns

Current-Mode PWM Controllers for Isolated Power Supplies

MAX5021/MAX5022

ELECTRICAL CHARACTERISTICS (continued)

($V_{IN} = +11V$ to $+28V$, $V_{CS} = 0$, OPTO is unconnected, 10nF bypass capacitors at V_{IN} and V_{CC} , NDRV unconnected, $T_A = -40^{\circ}C$ to $+85^{\circ}C$, unless otherwise noted. Typical values are at $V_{IN} = +12V$, $T_A = +25^{\circ}C$, unless otherwise noted.) (Note 1)

PARAMETER	SYMBOL	CONDITIONS	MIN	TYP	MAX	UNITS
OSCILLATOR						
Switching Frequency	f_{SW}		230	262	290	kHz
Maximum Duty Cycle	D_{MAX}	MAX5021		50	51	%
		MAX5022		75	76	
OPTO INPUT						
OPTO Pullup Voltage	V_{OPTO}	OPTO sourcing 10 μ A			5.5	V
OPTO Pullup Resistance	R_{OPTO}		4.5	6.2	7.9	k Ω

Note 1: All devices are 100% tested at $T_A = +25^{\circ}C$. All limits over temperature are guaranteed by characterization.

Note 2: This minimum current after startup is a safeguard that prevents the V_{IN} pin voltage from rising in the event that OPTO and NDRV become unconnected.

Typical Operating Characteristics

($V_{IN} = 15V$, $T_A = +25^{\circ}C$, unless otherwise noted.)

UNDERVOLTAGE LOCKOUT vs. TEMPERATURE

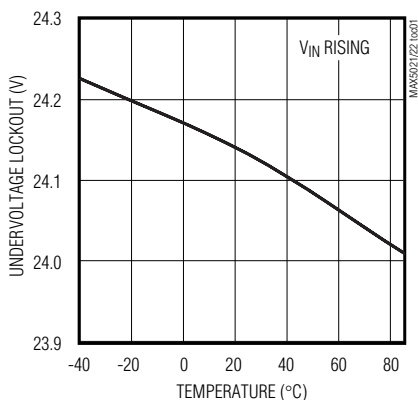

UNDERVOLTAGE LOCKOUT vs. TEMPERATURE

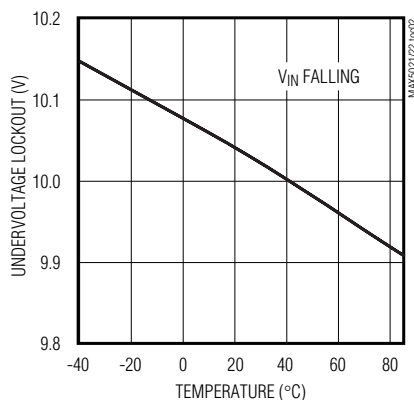

STARTUP CURRENT vs. TEMPERATURE

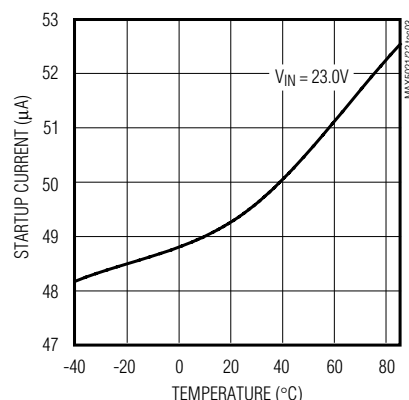

Current-Mode PWM Controllers for Isolated Power Supplies

Typical Operating Characteristics (continued)

($V_{IN} = 15V$, $T_A = +25^\circ C$, unless otherwise noted.)

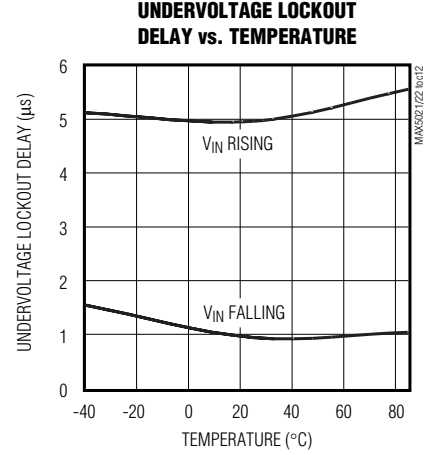
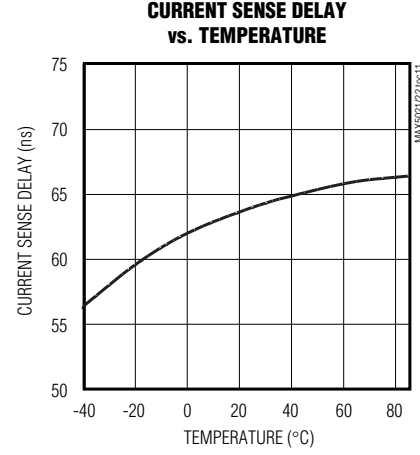
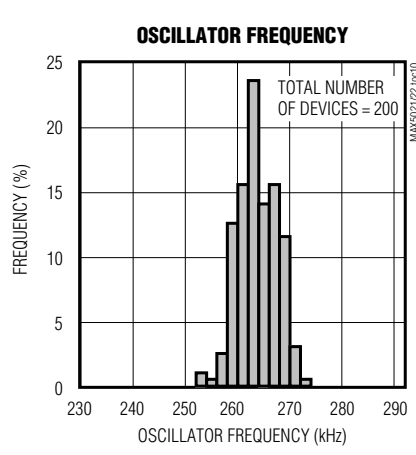
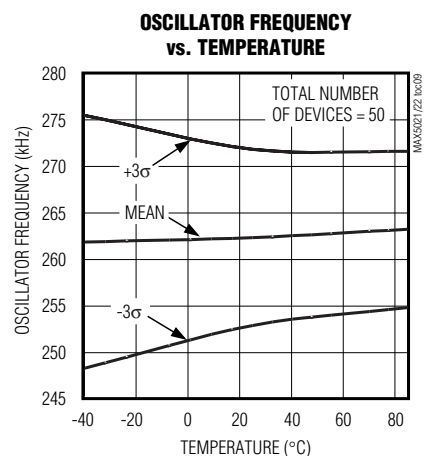
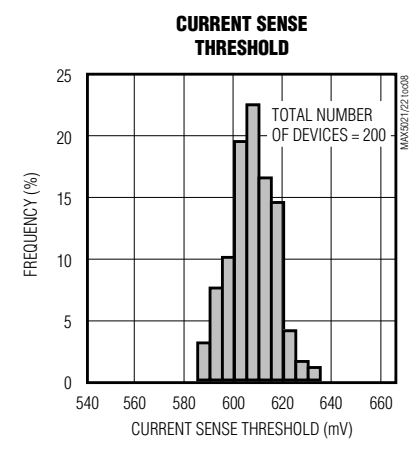
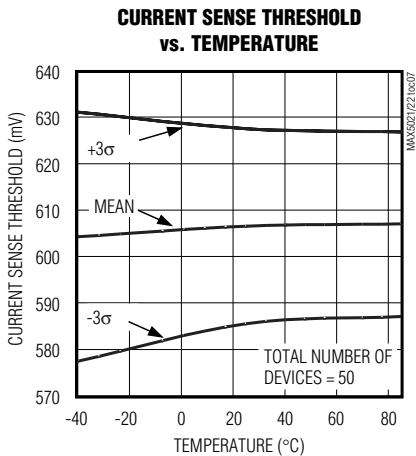
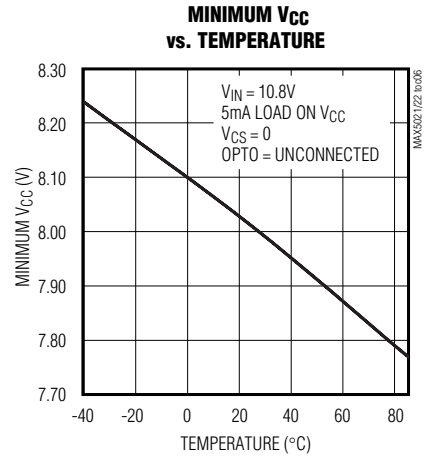
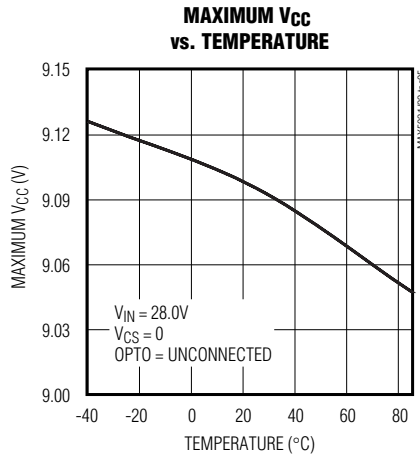
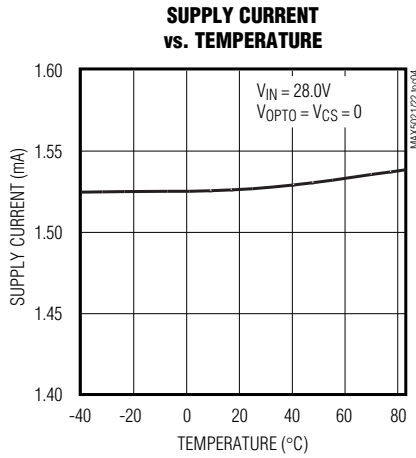

Current-Mode PWM Controllers for Isolated Power Supplies

Pin Description

MAX5021/MAX5022

PIN		NAME	FUNCTION
SOT23	PDIP μMAX		
1	8	CS	Current Sense Connection for PWM Regulation and Overcurrent Protection. The current-limit comparator threshold is internally set to 0.6V.
2	7	GND	Power-Supply Ground
3	6	NDRV	External N-Channel MOSFET Gate Connection
4	3	V _{CC}	Gate Drive Supply. Internally regulated down from V _{IN} . Decouple with a 10nF or larger capacitor to GND.
5	2	V _{IN}	IC Supply. Decouple with a 10nF or larger capacitor to GND. Connect a startup resistor (R _S) from the input supply line to V _{IN} . Connect to bias winding through diode rectifier. See <i>Typical Operating Circuit</i> .
6	1	OPTO	Optocoupler Transistor Collector Connection. Connect emitter of optocoupler to GND. The OPTO has an internal pullup resistor with a typical value of 6.2kΩ.
—	4, 5	N.C.	No Connection. Do not make connections to these pins.

Detailed Description

The MAX5021/MAX5022 are current-mode PWM controllers that have been specifically designed for use in isolated power supplies. An undervoltage lockout circuit (UVLO) with a large hysteresis (14V) along with very low startup and operating current result in high-efficiency, universal input power supplies. Both devices can be used in power supplies capable of operating from a universal 85VAC to 265VAC line or the telecom voltage range of -36VDC to -72VDC.

Power supplies designed with these devices use a high-value startup resistor, R_S, (series combination of R₁ and R₂) that charges a reservoir capacitor, C₂ (see Figure 1). During this initial period while the voltage is less than the UVLO start threshold, the IC typically consumes only 50μA of quiescent current. This low startup current and the large UVLO hysteresis combined with the use of a ceramic capacitor C₂ keeps the power dissipation in R_S to less than 1/4W even at the high end of the universal AC input voltage (265VAC).

The MAX5021/MAX5022 include a cycle-by-cycle current limit which turns off the gate drive to the external MOSFET during an overcurrent condition. If the output on the secondary side of transformer T₁ is shorted, the tertiary winding voltage will drop below the 10V threshold causing the UVLO circuit to turn off the gate drive to the external power MOSFET, thus re-initiating the startup sequence.

Startup

Figure 2 shows the voltages on V_{IN} and V_{CC} during startup. Initially, both V_{IN} and V_{CC} are 0V. After the line voltage is applied, C₂ charges through the startup resistor, R_S, to an intermediate voltage at which point the internal reference and regulator begin charging C₃ (see Figure 1). The bias current consumed by the device during this period is only 50μA; the remaining input current charges C₂ and C₃. Charging of C₃ stops when the V_{CC} voltage reaches approximately 9.5V, while the voltage across C₂ continues rising until it reaches the wakeup level of 24V. Once V_{IN} exceeds the UVLO threshold, NDRV begins switching the MOSFET, transferring energy to the secondary and tertiary outputs. If the voltage on the tertiary output builds to higher than 10V (UVLO lower threshold), then startup has been accomplished and sustained operation will commence.

If V_{IN} drops below 10V before startup is complete, then the IC goes back into UVLO. In this case, increase the value of C₂ and/or use a MOSFET with a lower gate-charge requirement.

Startup Time Considerations

The V_{IN} bypass capacitor C₂ supplies current immediately after wakeup. The size of C₂ will determine the number of cycles available for startup. Large values for C₂ will increase the startup time, but will also supply more gate charge, allowing for more cycles after wakeup. If the value of C₂ is too small, V_{IN} will drop below 10V because

Current-Mode PWM Controllers for Isolated Power Supplies

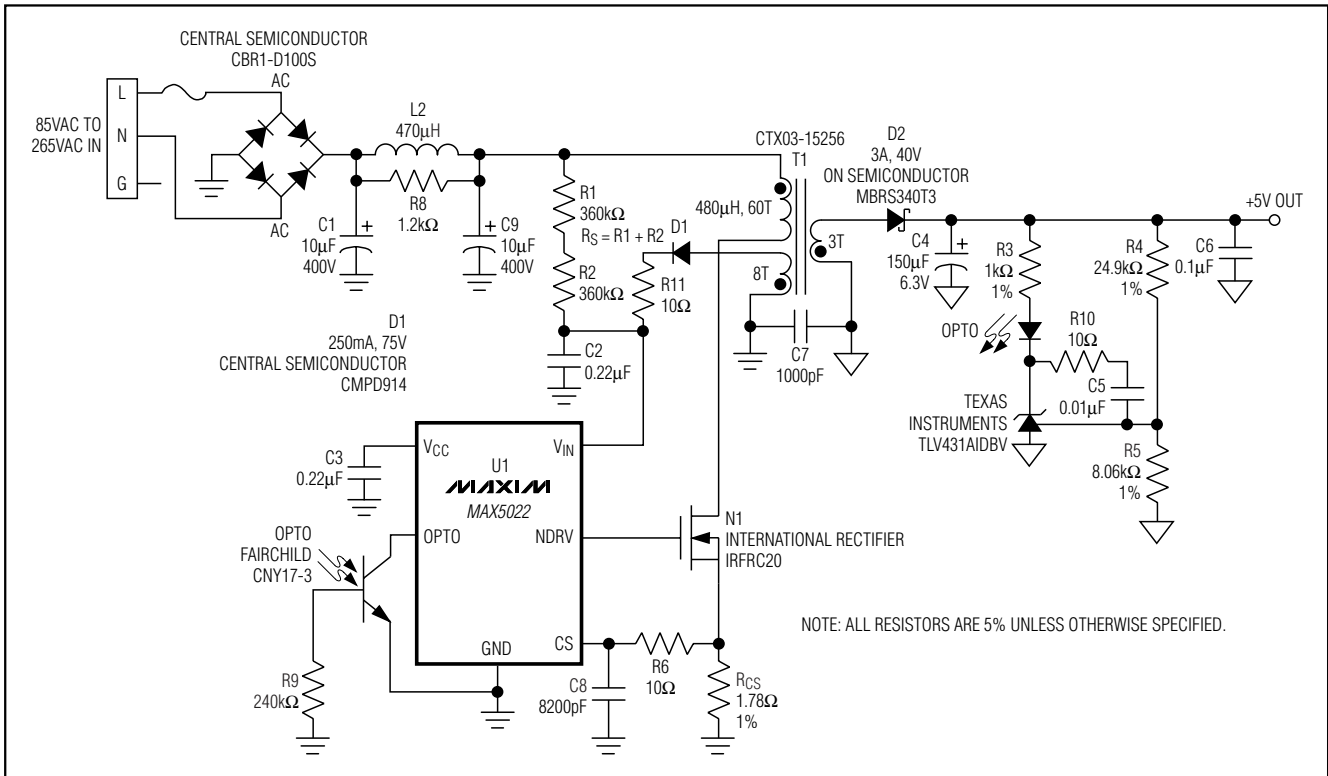

Figure 1. Universal 5W Off-Line Standby Power Supply

NDRV did not switch enough times to build up sufficient voltage across the tertiary output to power the device. The device will go back into UVLO and will not start. Use a low-leakage ceramic or film capacitor for C2 and C3.

As a rule of thumb, off-line power supplies keep typical startup times to less than 500ms even in low-line conditions (85VAC input). Size the startup resistor, R_S , to supply the maximum startup bias of the IC (85µA) plus the additional current required for charging the capacitors C2 and C3 in less than 500ms. This resistor dissipates continuous power in normal operation, despite the fact that it is only used during the startup sequence. Therefore it must be chosen to provide enough current for the low-line condition as well as have an appropriate power rating for the high-line condition (265VAC). In most cases, split the value into two resistors connected in series for the required voltage of approximately 400VDC.

The typical value for C2 and C3 is 220nF. The startup resistor, R_S , provides both the maximum quiescent current of 85µA and the charging current for C2 and C3. Bypass capacitor C3 charges to 9.5V and C2 charges

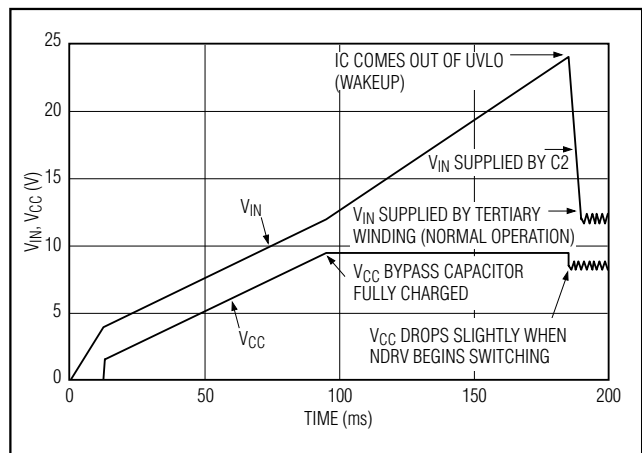

Figure 2. V_{IN} and V_{CC} During Startup

to 24V all within the desired time period of 500ms, for an overall average charging current of 15µA. Hence, the startup resistor must provide a total of at least 100µA. Developing 100µA from an input voltage of

Current-Mode PWM Controllers for Isolated Power Supplies

85VAC (corresponding to 120VDC) to the 24V wakeup level results in a resistor value of about 1M Ω . If we assume R_S values between 750k Ω and 1M Ω , then at the high-line voltage of 265VAC (corresponding to 374VDC) power dissipation will be between 140mW to 190mW. A single 1/4W resistor or a series combination of two 1/4W resistors is adequate.

Undervoltage Lockout (UVLO)

The device will attempt to start when V_{IN} exceeds the UVLO threshold of 24V. During startup, the UVLO circuit keeps the CPWM comparator, ILIM comparator, oscillator, and output driver shut down to reduce current consumption (*Functional Diagram*). Once V_{IN} reaches 24V, the UVLO circuit turns on both the CPWM and ILIM comparators, as well as the oscillator, and allows the output driver to switch. If V_{IN} drops below 10V, the UVLO circuit will shut down the CPWM comparator, ILIM comparator, oscillator, and output driver returning the MAX5021/MAX5022 to the startup mode.

N-Channel MOSFET Switch Driver

The NDRV pin drives an external N-channel MOSFET. The NDRV output is supplied by the internal regulator (V_{CC}), which is internally set to approximately 9V. For the universal input voltage range, the MOSFET used must be able to withstand the DC level of the high-line input voltage plus the reflected voltage at the primary of the transformer. For most applications that use the discontinuous flyback topology, this requires a MOSFET rated at 600V. NDRV can source/sink 150mA/250mA peak current, thus select a MOSFET that will yield acceptable conduction and switching losses.

Internal Oscillator

The internal oscillator switches at 1.048MHz and is divided down to 262kHz by two D flip-flops. The MAX5021 inverts the Q output of the last D flip-flop to provide a duty cycle of 50% (Figure 3). The MAX5022 performs a logic NAND operation on the Q outputs of both D flip-flops to provide a duty cycle of 75%.

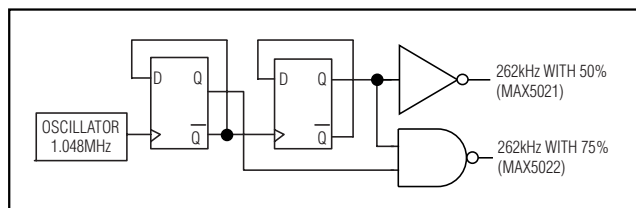

Figure 3. Internal Oscillator

Optocoupler Feedback

The MAX5021/MAX5022 do not include an internal error amplifier and are recommended for use in optocoupler feedback power supplies. Isolated voltage feedback is achieved by using an optocoupler and a shunt regulator as shown in the *Typical Operating Circuit*. The output voltage set point accuracy is a function of the accuracy of the shunt regulator and resistor divider.

When a TLV431 shunt regulator is used for output voltage regulation, the output voltage is set by the ratio of R₄ and R₅ (Figure 1). Output voltage is given by the following equation:

$$V_{OUT} = V_{REF} \times \left(1 + \frac{R_4}{R_5} \right)$$

where V_{REF} = 1.24V for the TLV431.

During normal operation, the optocoupler feedback pin (OPTO) is pulled up through a 6.2k Ω resistor to the internal supply voltage of 5.25V. When the device is in UVLO, OPTO is disconnected from the 5.25V regulator and connected to ground (*Functional Diagram*). This helps initial startup by reducing the current consumption of the device.

Current Limit

The current limit is set by a current sense resistor, R_{CS}, connected between the source of the MOSFET and ground. The CS input has a voltage trip level (V_{CS}) of 600mV. Use the following equation to calculate the value of R_{CS}:

$$R_{CS} = \frac{V_{CS}}{I_{PRI}}$$

where I_{PRI} is the peak current in the primary that flows through the MOSFET. When the voltage produced by this current through the current sense resistor exceeds the current-limit comparator threshold, the MOSFET driver (NDRV) will quickly terminate the current ON-cycle, typically within 60ns. In most cases a small RC filter will be required to filter out the leading-edge spike on the sense waveform. Set the corner frequency at a few MHz.

Applications Information

Universal Off-Line Power Supply

Figure 1 shows the design of a 5V/1A isolated power supply capable of operating from a line voltage of 85VAC to 265VAC. This circuit is implemented in the MAX5022EVKIT.

Current-Mode PWM Controllers for Isolated Power Supplies

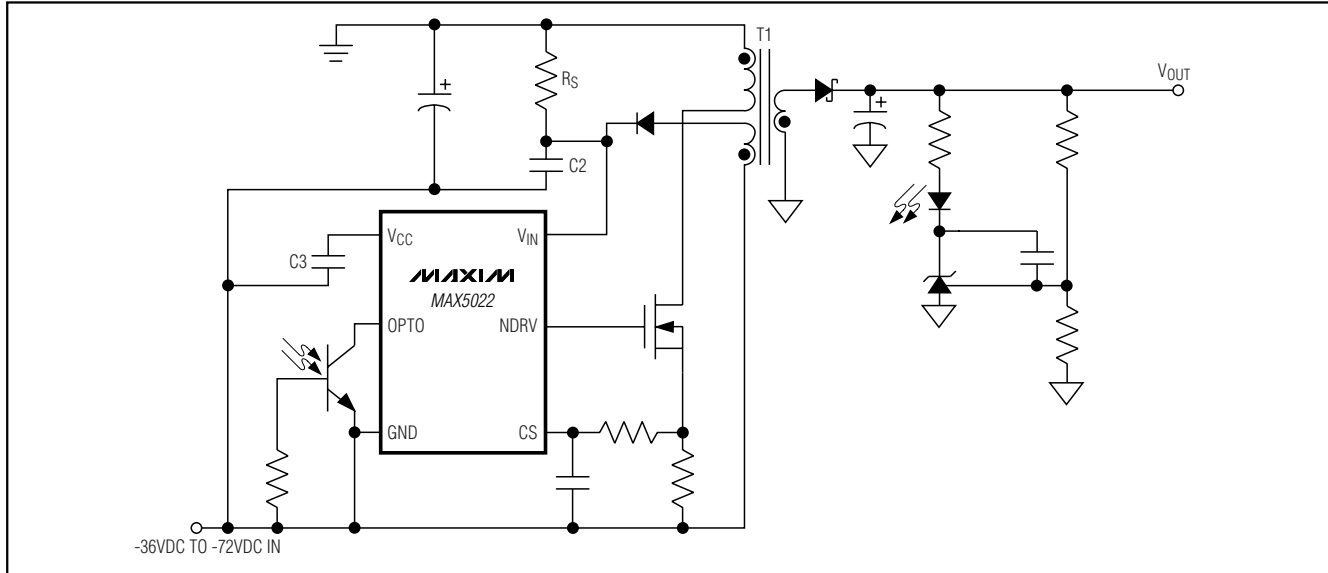

Figure 4. -48VDC Input to +5V Output

WARNING! DANGEROUS AND LETHAL VOLTAGES ARE PRESENT IN OFF-LINE CIRCUITS! USE EXTREME CAUTION IN THE CONSTRUCTION, TESTING, AND USE OF OFF-LINE CIRCUITS.

Isolated Telecom Power Supply

Figure 4 shows a -48VDC telecom power supply capable of generating an isolated +5V output.

Layout Recommendations

All printed circuit board traces carrying switching currents must be kept as short as possible, and the current loops they form must be minimized. The pins of the SOT23 package have been placed to allow simple interfacing to the external MOSFET. The order of these pins directly corresponds to the order of a TO-220 or similar package MOSFET.

For universal AC input design all applicable safety regulations must be followed. Off-line power supplies may require UL, VDE, and other similar agency approvals. These agencies can be contacted for the latest layout and component rules.

Typically there are two sources of noise emission in a switching power supply: high di/dt loops and high dv/dt surfaces. For example, traces that carry the drain current often form high di/dt loops. Similarly the heatsink of the MOSFET presents a dv/dt source, thus the surface area of the heatsink must be minimized as much as possible.

To achieve best performance, a star ground connection is recommended to avoid ground loops. For example, the ground returns for the power-line input filter, power MOSFET switch, and sense resistor should be routed separately through wide copper traces to meet at a single system ground connection.

Chip Information

TRANSISTOR COUNT: 519

PROCESS: BiCMOS

Current-Mode PWM Controllers for Isolated Power Supplies

Functional Diagram

MAX5021/MAX5022

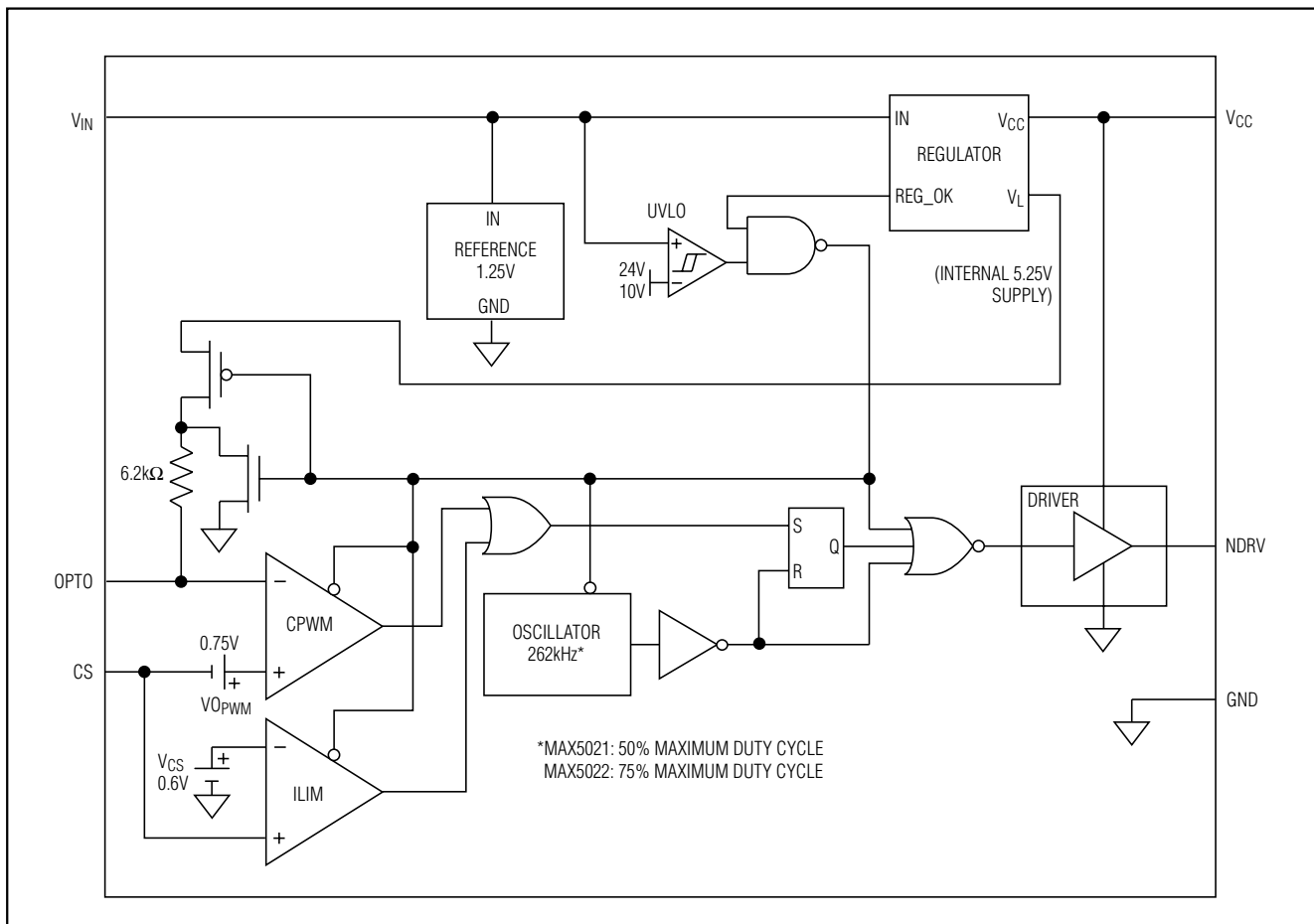

Current-Mode PWM Controllers for Isolated Power Supplies

Package Information

SYMBOL	MIN	MAX
A	0.90	1.45
A1	0.00	0.15
A2	0.90	1.30
b	0.35	0.50
c	0.08	0.20
D	2.80	3.00
E	2.60	3.00
E1	1.50	1.75
L	0.35	0.55
e	0.95 REF	
α	0°	10°

NOTES:
 1. ALL DIMENSIONS ARE IN MILLIMETERS.
 2. FOOT LENGTH MEASURED AT INTERCEPT POINT BETWEEN DATUM A & LEAD SURFACE.
 3. PACKAGE OUTLINE EXCLUSIVE OF MOLD FLASH & METAL BURR.
 4. PACKAGE OUTLINE INCLUSIVE OF SOLDER PLATING.
 5. PIN 1 IS LOWER LEFT PIN WHEN READING TOP MARK FROM LEFT TO RIGHT. (SEE EXAMPLE TOP MARK)
 6. PIN 1 I.D. DOT IS 0.3 MM Ø MIN. LOCATED ABOVE PIN 1.
 7. MEETS JEDEC MO178.

6/SOT23

PROPRIETARY INFORMATION			
TITLE: PACKAGE OUTLINE, SOT-23, 6L			
APPROVAL:	DOCUMENT CONTROL NO. 21-0058	REV E	1/1

NOTES:
 1. D&E DO NOT INCLUDE MOLD FLASH.
 2. MOLD FLASH OR PROTRUSIONS NOT TO EXCEED 0.15MM (.006").
 3. CONTROLLING DIMENSION: MILLIMETERS.
 4. MEETS JEDEC MO-187C-AA.

PROPRIETARY INFORMATION			
TITLE: PACKAGE OUTLINE, 8L uMAXuSOP			
APPROVAL:	DOCUMENT CONTROL NO. 21-0036	REV J	1/1

Current-Mode PWM Controllers for Isolated Power Supplies

Package Information (continued)

MAX5021/MAX5022

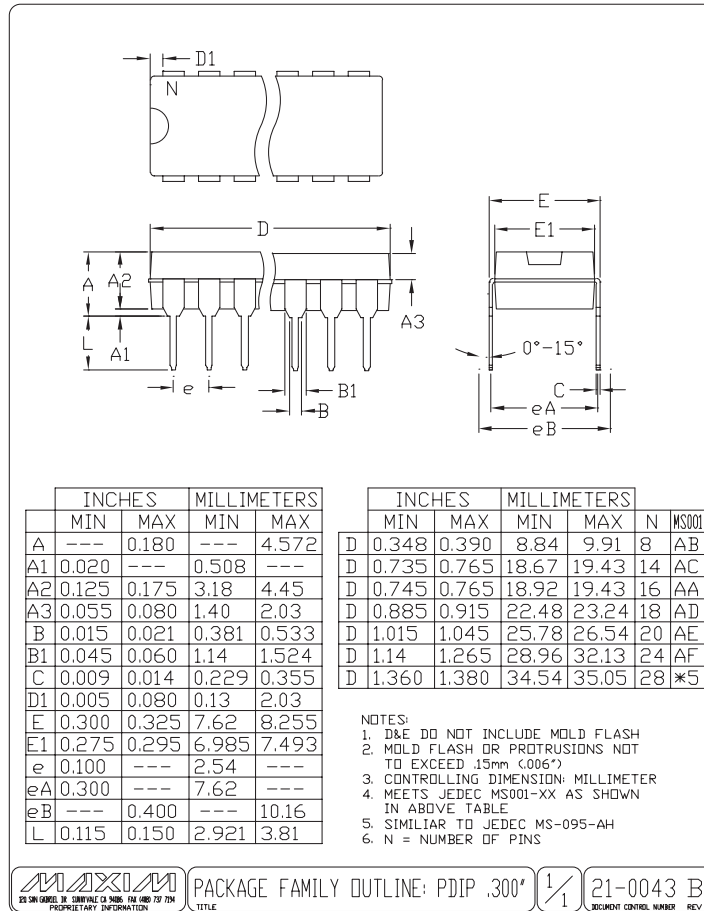

Maxim cannot assume responsibility for use of any circuitry other than circuitry entirely embodied in a Maxim product. No circuit patent licenses are implied. Maxim reserves the right to change the circuitry and specifications without notice at any time.

Maxim Integrated Products, 120 San Gabriel Drive, Sunnyvale, CA 94086 408-737-7600 _____ 11

Looking for pricing, stock, or lifecycle information?

Click below to explore more details on WIN SOURCE:

 [View MAX5021EUT+T on WIN SOURCE](#)

 [Maxim Integrated](#) Information

Optimize Your Supply Chain with WIN SOURCE Solutions

-  Global Sourcing Solution
-  Obsolete Management
-  Cost Control Management
-  Shortage Management
-  Alternative Solution
-  Excess Inventory Management