



**THE DATASHEET OF  
MAX5078BATT+T**



## 4A, 20ns, MOSFET Driver

### General Description

The MAX5078A/MAX5078B high-speed MOSFET drivers source and sink up to 4A peak current. These devices feature a fast 20ns propagation delay and 20ns rise and fall times while driving a 5000pF capacitive load. Propagation delay time is minimized and matched between the inverting and noninverting inputs. High sourcing/sinking peak currents, low propagation delay, and thermally enhanced packages make the MAX5078A/MAX5078B ideal for high-frequency and high-power circuits.

The MAX5078A/MAX5078B operate from a 4V to 15V single power supply and consume 40 $\mu$ A (typ) of supply current when not switching. These devices have an internal logic circuitry that prevents shoot-through during output state changes to minimize the operating current at a high switching frequency. The logic inputs are protected against voltage spikes up to +18V, regardless of the V<sub>DD</sub> voltage. The MAX5078A has CMOS input logic levels while the MAX5078B has TTL-compatible input logic levels.

The MAX5078A/MAX5078B feature both inverting and noninverting inputs for greater flexibility in controlling the MOSFET. They are available in a 6-pin TDFN (3mm x 3mm) package and operate over the automotive temperature range of -40°C to +125°C.

### Applications

Power MOSFET Switching      Motor Control  
Switch-Mode Power Supplies      Power-Supply Modules  
DC-DC Converters

### Typical Operating Circuit

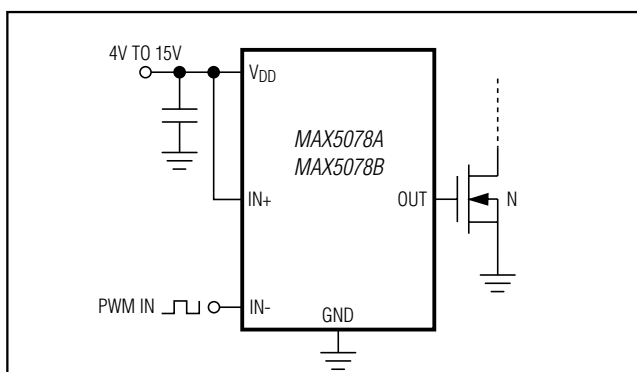

### Features

- ◆ 4V to 15V Single Power Supply
- ◆ 4A Peak Source/Sink Drive Current
- ◆ 20ns (typ) Propagation Delay
- ◆ Matching Delay Between Inverting and Noninverting Inputs
- ◆ V<sub>DD</sub> / 2 CMOS (MAX5078A)/TTL (MAX5078B) Logic Inputs
- ◆ 0.1 x V<sub>DD</sub> (CMOS) and 0.3V (TTL) Logic-Input Hysteresis
- ◆ Up to +18V Logic Inputs (Regardless of V<sub>DD</sub> Voltage)
- ◆ Low Input Capacitance: 2.5pF (typ)
- ◆ 40 $\mu$ A (typ) Quiescent Current
- ◆ -40°C to +125°C Operating Temperature Range
- ◆ 6-Pin TDFN Package

### Ordering Information

PART	TEMP RANGE	PIN-PACKAGE
MAX5078AATT+	-40°C to +125°C	6 TDFN-EP*
MAX5078AATT/V+	-40°C to +125°C	6 TDFN-EP*
MAX5078BATT+	-40°C to +125°C	6 TDFN-EP*
MAX5078BATT/V+	-40°C to +125°C	6 TDFN-EP*

\*EP = Exposed pad.

+Denotes a lead(Pb)-free/RoHS-compliant package.

\*EP = Exposed pad.

/V denotes an automotive qualified part.

**Note:** Devices are also available in a tape-and-reel package. Specify tape and reel by adding "T" to the part number when ordering.

### Selector Guide

PART	PIN-PACKAGE	LOGIC INPUT
MAX5078AATT	6 TDFN-EP	V <sub>DD</sub> / 2 CMOS
MAX5078BATT	6 TDFN-EP	TTL

### Pin Configuration

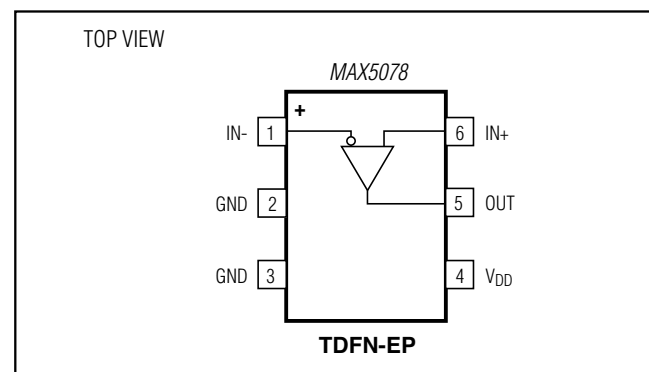

**For pricing, delivery, and ordering information, please contact Maxim Direct at 1-888-629-4642, or visit Maxim's website at [www.maximintegrated.com](http://www.maximintegrated.com).**

# MAX5078

## 4A, 20ns, MOSFET Driver

### ABSOLUTE MAXIMUM RATINGS

(Voltages referenced to GND.)

V <sub>DD</sub> .....	-0.3V to +18V
IN+, IN- .....	-0.3V to +18V
OUT .....	-0.3V to (V <sub>DD</sub> + 0.3V)
OUT Short-Circuit Duration.....	10ms
Continuous Source/Sink Current at OUT_ (P <sub>D</sub> < P <sub>D</sub> MAX).....	200mA

Continuous Power Dissipation (T<sub>A</sub> = +70°C)

6-Pin TDFN-EP (derate 18.2mW/°C above +70°C).....	1454mW
Operating Temperature Range.....	-40°C to +125°C
Storage Temperature Range .....	-65°C to +150°C
Junction Temperature.....	+150°C
Lead Temperature (soldering, 10s).....	+300°C
Soldering Temperature (reflow).....	+260°C

Stresses beyond those listed under "Absolute Maximum Ratings" may cause permanent damage to the device. These are stress ratings only, and functional operation of the device at these or any other conditions beyond those indicated in the operational sections of the specifications is not implied. Exposure to absolute maximum rating conditions for extended periods may affect device reliability.

### PACKAGE THERMAL CHARACTERISTICS (Note 1)

Junction-to-Ambient Thermal Resistance (θ <sub>JA</sub> ).....	42°C/W
Junction-to-Case Thermal Resistance (θ <sub>JC</sub> ).....	9°C/W

**Note 1:** Package thermal resistances were obtained using the method described in JEDEC specification JESD51-7, using a four-layer board. For detailed information on package thermal considerations, refer to [www.maximintegrated.com/thermal-tutorial](http://www.maximintegrated.com/thermal-tutorial).

### ELECTRICAL CHARACTERISTICS

(V<sub>DD</sub> = 4V to 15V, T<sub>A</sub> = -40°C to +125°C, unless otherwise noted. Typical values are at V<sub>DD</sub> = 15V and T<sub>A</sub> = +25°C.) (Note 1)

PARAMETER	SYMBOL	CONDITIONS	MIN	TYP	MAX	UNITS
<b>POWER SUPPLY</b>						
V <sub>DD</sub> Operating Range	V <sub>DD</sub>		4		15	V
V <sub>DD</sub> Undervoltage Lockout	UVLO	V <sub>DD</sub> rising	3.00	3.5	3.85	V
V <sub>DD</sub> Undervoltage Lockout Hysteresis				200		mV
V <sub>DD</sub> Undervoltage Lockout to Output Delay		V <sub>DD</sub> rising		12		µs
V <sub>DD</sub> Supply Current	I <sub>DD</sub>	V <sub>IN+</sub> = 0V, IN- = V <sub>DD</sub> (not switching)	V <sub>DD</sub> = 4V	28	55	µA
			V <sub>DD</sub> = 15V	40	75	
	I <sub>DD-SW</sub>	Switching at 250kHz, C <sub>L</sub> = 0	0.5	1.2	2.2	mA
<b>DRIVER OUTPUT (SINK)</b>						
Driver Output Resistance Pulling Down	R <sub>ON-N</sub>	V <sub>DD</sub> = 15V, I <sub>OUT</sub> = -100mA	T <sub>A</sub> = +25°C	1.1	1.8	Ω
			T <sub>A</sub> = +125°C	1.5	2.4	
		V <sub>DD</sub> = 4.5V, I <sub>OUT</sub> = -100mA	T <sub>A</sub> = +25°C	2.2	3.3	
			T <sub>A</sub> = +125°C	3.0	4.5	
Peak Output Current (Sinking)	I <sub>PK-N</sub>	V <sub>DD</sub> = 15V, C <sub>L</sub> = 10,000pF		4		A
Output-Voltage Low		I <sub>OUT</sub> = -100mA	V <sub>DD</sub> = 4.5V		0.45	V
			V <sub>DD</sub> = 15V		0.24	
Latchup Protection	I <sub>LUP</sub>	Reverse current I <sub>OUT</sub> (Note 2)	400			mA
<b>DRIVER OUTPUT (SOURCE)</b>						
Driver Output Resistance Pulling Up	R <sub>ON-P</sub>	V <sub>DD</sub> = 15V, I <sub>OUT</sub> = 100mA	T <sub>A</sub> = +25°C	1.5	2.1	Ω
			T <sub>A</sub> = +125°C	1.9	2.75	
		V <sub>DD</sub> = 4.5V, I <sub>OUT</sub> = 100mA	T <sub>A</sub> = +25°C	2.75	4	
			T <sub>A</sub> = +125°C	3.75	5.5	
Peak Output Current (Sourcing)	I <sub>PK-P</sub>	V <sub>DD</sub> = 15V, C <sub>L</sub> = 10,000pF		4		A

# MAX5078

## 4A, 20ns, MOSFET Driver

### ELECTRICAL CHARACTERISTICS (continued)

( $V_{DD} = 4V$  to  $15V$ ,  $T_A = -40^{\circ}C$  to  $+125^{\circ}C$ , unless otherwise noted. Typical values are at  $V_{DD} = 15V$  and  $T_A = +25^{\circ}C$ .) (Note 1)

PARAMETER	SYMBOL	CONDITIONS	MIN	TYP	MAX	UNITS
Output-Voltage High		$I_{OUT} = 100mA$	$V_{DD} = 4.5V$	$V_{DD} - 0.55$		V
			$V_{DD} = 15V$	$V_{DD} - 0.275$		
<b>LOGIC INPUT (Note 3)</b>						
Logic 1 Input Voltage	$V_{IH}$	MAX5078A	$0.7 \times V_{DD}$		V	
		MAX5078B (Note 4)	2.1			
Logic 0 Input Voltage	$V_{IL}$	MAX5078A	$0.3 \times V_{DD}$		V	
		MAX5078B	0.8			
Logic-Input Hysteresis	$V_{HYS}$	MAX5078A	$0.1 \times V_{DD}$		V	
		MAX5078B	0.3			
Logic-Input-Current Leakage		$V_{IN+} = V_{IN-} = 0V$ or $V_{DD}$	-1	+0.1	+1	$\mu A$
Input Capacitance	$C_{IN}$		2.5		pF	
<b>SWITCHING CHARACTERISTICS FOR <math>V_{DD} = 15V</math> (Figure 1)</b>						
OUT Rise Time	$t_R$	$C_L = 1000pF$	4		ns	
		$C_L = 5000pF$	18			
		$C_L = 10,000pF$	32			
OUT Fall Time	$t_F$	$C_L = 1000pF$	4		ns	
		$C_L = 5000pF$	15			
		$C_L = 10,000pF$	26			
Turn-On Delay Time	$t_{D-ON}$	$C_L = 10,000pF$ (Note 2)	10	20	34	ns
Turn-Off Delay Time	$t_{D-OFF}$	$C_L = 10,000pF$ (Note 2)	10	20	34	ns
<b>SWITCHING CHARACTERISTICS FOR <math>V_{DD} = 4.5V</math> (Figure 1)</b>						
OUT Rise Time	$t_R$	$C_L = 1000pF$	7		ns	
		$C_L = 5000pF$	37			
		$C_L = 10,000pF$	85			
OUT Fall Time	$t_F$	$C_L = 1000pF$	7		ns	
		$C_L = 5000pF$	30			
		$C_L = 10,000pF$	75			
Turn-On Delay Time	$t_{D-ON}$	$C_L = 10,000pF$ (Note 2)	18	35	70	ns
Turn-Off Delay Time	$t_{D-OFF}$	$C_L = 10,000pF$ (Note 2)	18	35	70	ns

# MAX5078

## 4A, 20ns, MOSFET Driver

### ELECTRICAL CHARACTERISTICS (continued)

( $V_{DD} = 4V$  to  $15V$ ,  $T_A = -40^\circ C$  to  $+125^\circ C$ , unless otherwise noted. Typical values are at  $V_{DD} = 15V$  and  $T_A = +25^\circ C$ .) (Note 1)

PARAMETER	SYMBOL	CONDITIONS	MIN	TYP	MAX	UNITS
<b>MATCHING CHARACTERISTICS</b>						
Mismatch Propagation Delays from Inverting and Noninverting Inputs to Output	$\Delta t_{ON-OFF}$	$V_{DD} = 15V$ , $C_L = 10,000pF$		2		ns
		$V_{DD} = 4.5V$ , $C_L = 10,000pF$		4		

**Note 1:** All devices are 100% tested at  $T_A = +25^\circ C$ . Specifications over  $-40^\circ C$  to  $+125^\circ C$  are guaranteed by design.

**Note 2:** Limits are guaranteed by design, not production tested.

**Note 3:** The logic-input thresholds are tested at  $V_{DD} = 4V$  and  $V_{DD} = 15V$ .

**Note 4:** TTL compatible with reduced noise immunity.

### Typical Operating Characteristics

( $T_A = +25^\circ C$ , unless otherwise noted.)

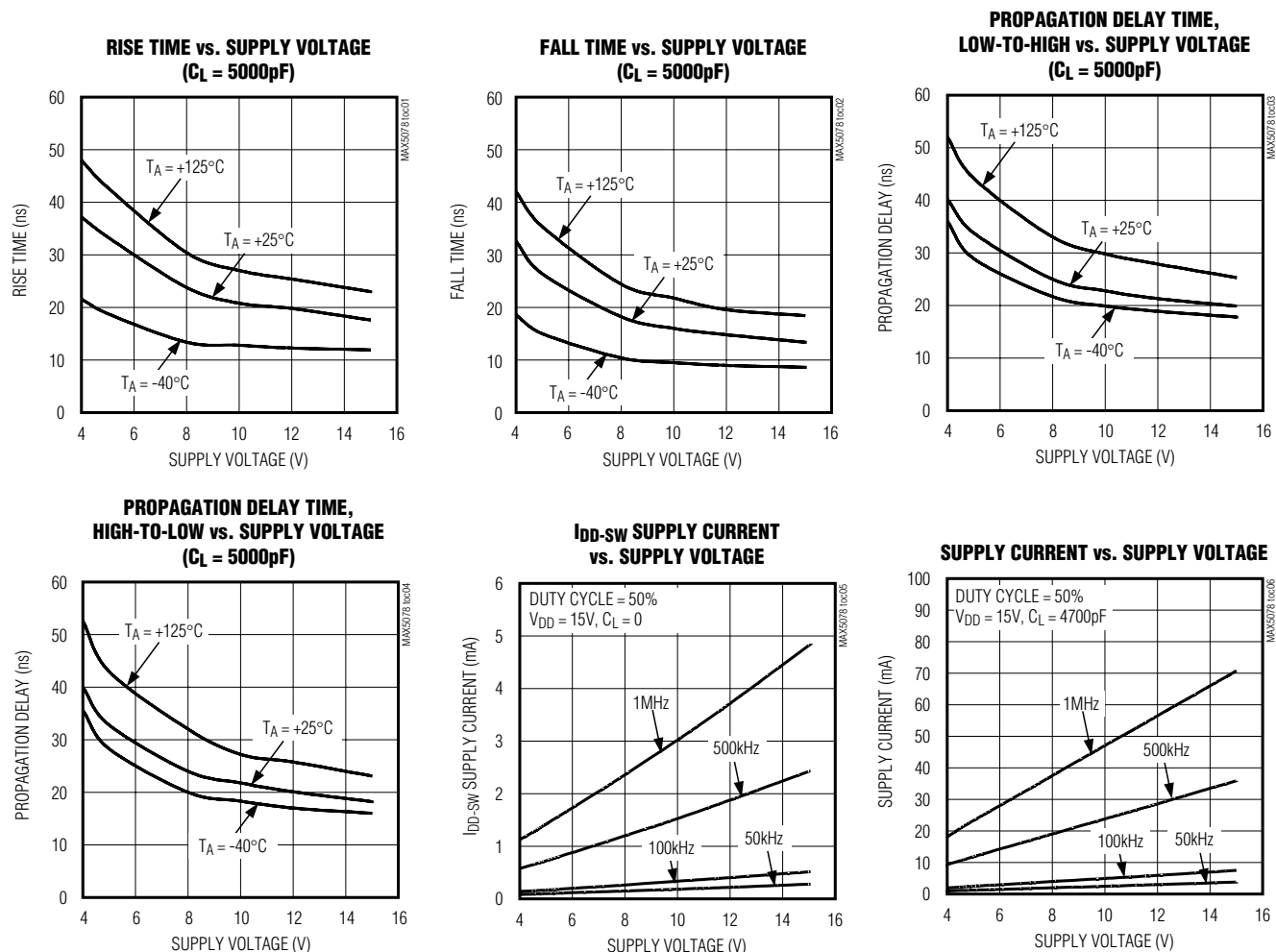

# MAX5078

## 4A, 20ns, MOSFET Driver

### Typical Operating Characteristics (continued)

( $T_A = +25^\circ\text{C}$ , unless otherwise noted.)

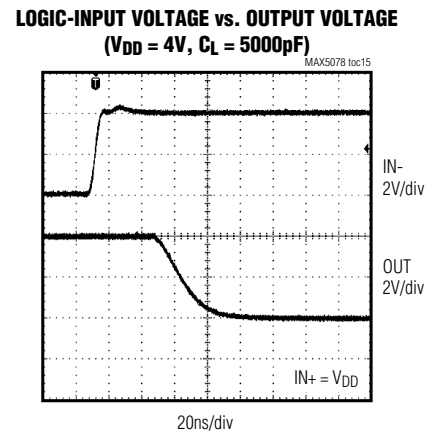
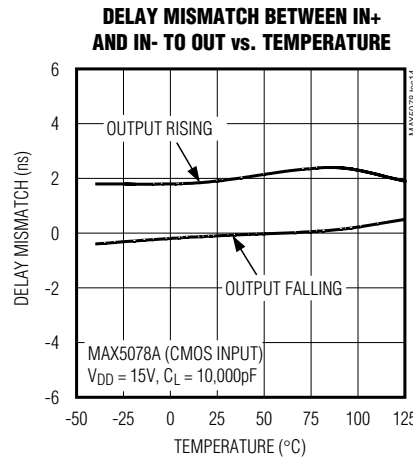
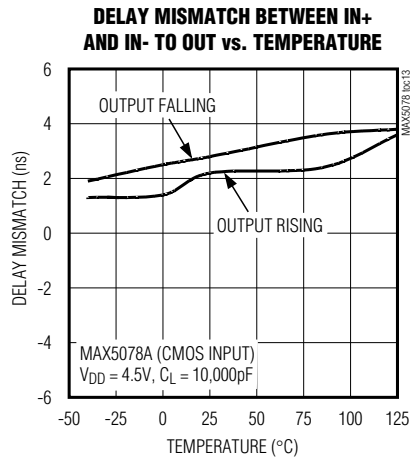
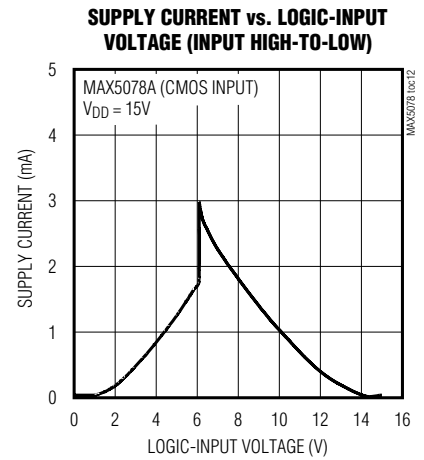
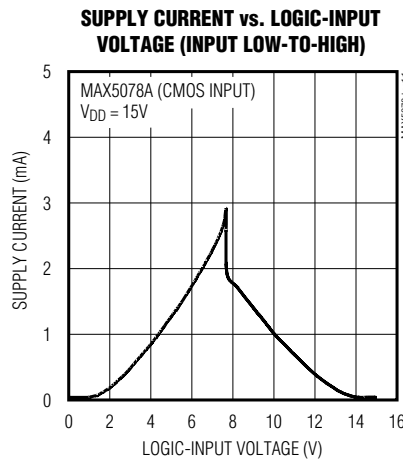
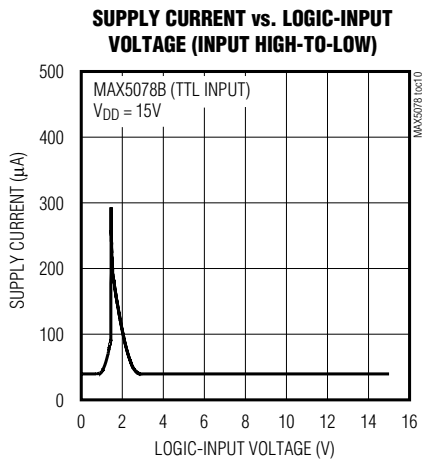
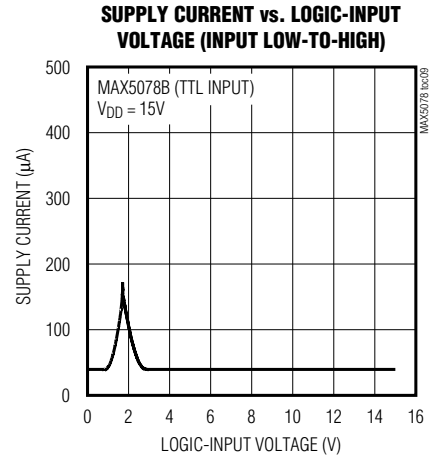
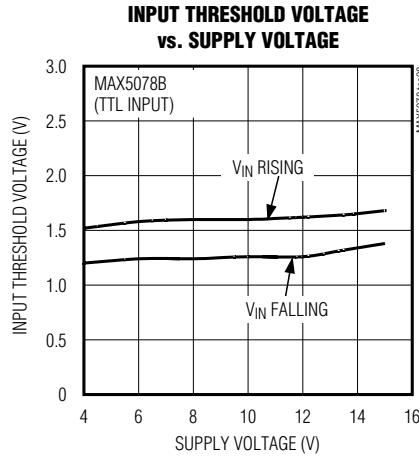
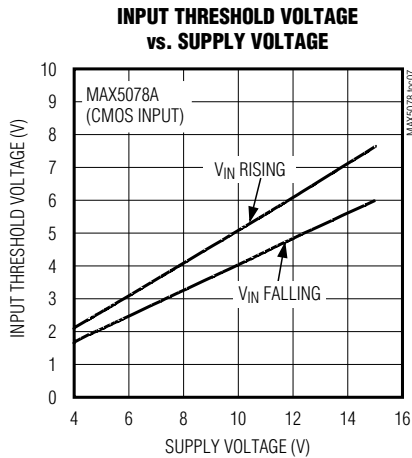

# MAX5078

## 4A, 20ns, MOSFET Driver

### Typical Operating Characteristics (continued)

( $T_A = +25^\circ\text{C}$ , unless otherwise noted.)

**LOGIC-INPUT VOLTAGE vs. OUTPUT VOLTAGE**  
( $V_{DD} = 4\text{V}$ ,  $C_L = 10,000\text{pF}$ )

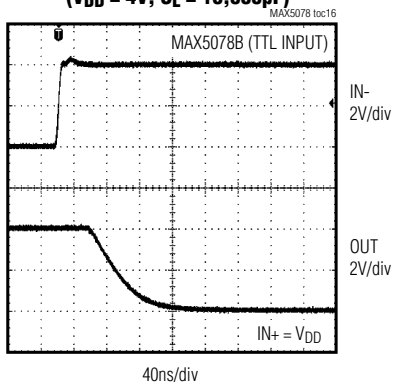

**LOGIC-INPUT VOLTAGE vs. OUTPUT VOLTAGE**  
( $V_{DD} = 4\text{V}$ ,  $C_L = 5000\text{pF}$ )

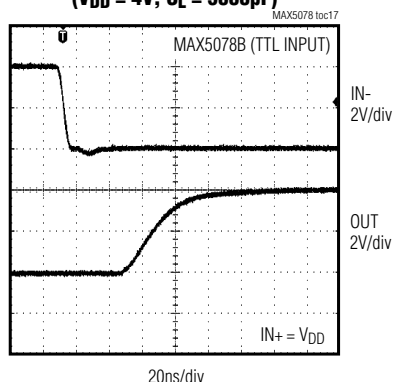

**LOGIC-INPUT VOLTAGE vs. OUTPUT VOLTAGE**  
( $V_{DD} = 4\text{V}$ ,  $C_L = 10,000\text{pF}$ )

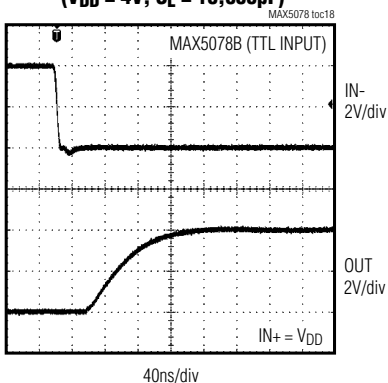

**LOGIC-INPUT VOLTAGE vs. OUTPUT VOLTAGE**  
( $V_{DD} = 15\text{V}$ ,  $C_L = 5000\text{pF}$ )

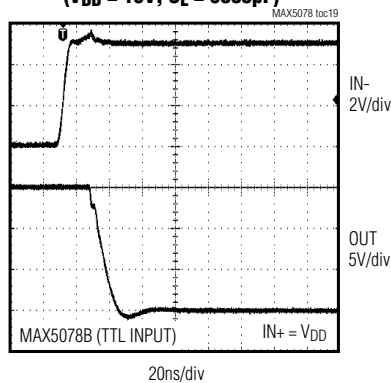

**LOGIC-INPUT VOLTAGE vs. OUTPUT VOLTAGE**  
( $V_{DD} = 15\text{V}$ ,  $C_L = 10,000\text{pF}$ )

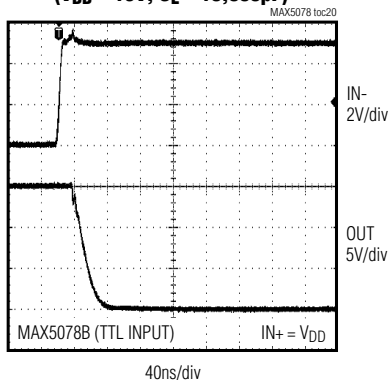

# MAX5078

## 4A, 20ns, MOSFET Driver

### Typical Operating Characteristics (continued)

( $T_A = +25^\circ\text{C}$ , unless otherwise noted.)

**LOGIC-INPUT VOLTAGE vs. OUTPUT VOLTAGE**  
( $V_{DD} = 15\text{V}$ ,  $C_L = 5000\text{pF}$ )

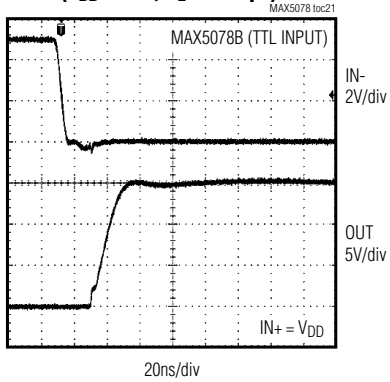

**LOGIC-INPUT VOLTAGE vs. OUTPUT VOLTAGE**  
( $V_{DD} = 15\text{V}$ ,  $C_L = 10,000\text{pF}$ )

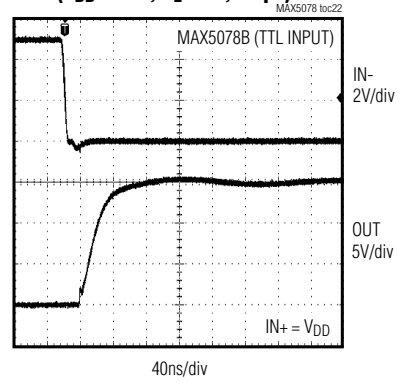

**$V_{DD}$  vs. OUTPUT VOLTAGE**

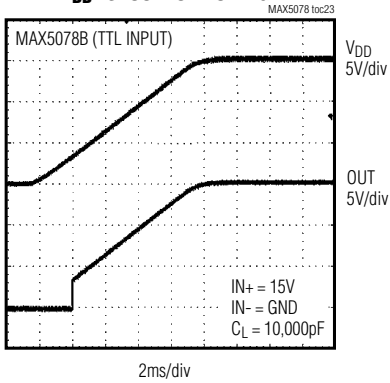

**$V_{DD}$  vs. OUTPUT VOLTAGE**

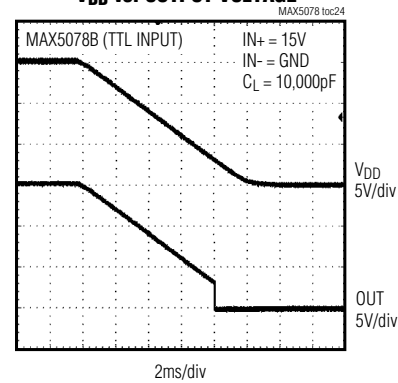

# MAX5078

## 4A, 20ns, MOSFET Driver

### Pin Description

PIN	NAME	FUNCTION
1	IN-	Inverting Logic-Input Terminal. Connect to GND when not used.
2, 3	GND	Ground
4	V <sub>DD</sub>	Power Supply. Bypass to GND with one or more 0.1µF ceramic capacitors.
5	OUT	Driver Output. Sources or sinks current to turn the external MOSFET on or off.
6	IN+	Noninverting Logic-Input Terminal. Connect to V <sub>DD</sub> when not used.
—	EP	Exposed Pad. Internally connected to GND. Do not use the exposed pad as the only electrical ground connection.

### Detailed Description

#### V<sub>DD</sub> Undervoltage Lockout (UVLO)

The MAX5078A/MAX5078B have internal undervoltage lockout (UVLO) for V<sub>DD</sub>. When V<sub>DD</sub> is below the UVLO threshold, OUT is pulled low independent of the state of the inputs. The undervoltage lockout is typically 3.5V with 200mV typical hysteresis to avoid chattering. When V<sub>DD</sub> rises above the UVLO threshold, the output goes high or low depending upon the logic-input levels. Bypass V<sub>DD</sub> using a low-ESR ceramic capacitor for proper operation (see the *Applications Information* section).

#### Logic Inputs

The MAX5078A has CMOS logic inputs while the MAX5078B has TTL-compatible logic inputs. The logic inputs are protected against the voltage spikes up to 18V, regardless of the V<sub>DD</sub> voltage. The TTL and CMOS logic inputs have 300mV and 0.1 × V<sub>DD</sub> hysteresis, respectively, to avoid double pulsing during transition. The low 2.5pF input capacitance reduces loading and increases switching speed.

The logic inputs are high impedance and must not be left floating. If the inputs are left open, OUT can go to an undefined state as soon as V<sub>DD</sub> rises above the UVLO threshold. Therefore, the PWM output from the controller must assume proper state when powering up the device.

The MAX5078A/MAX5078B have two logic inputs, providing greater flexibility in controlling the MOSFET. Use IN+ for noninverting logic and IN- for inverting logic operation. Connect IN+ to V<sub>DD</sub> and IN- to GND, if not used. Alternatively, the unused input can be used as an ON/OFF function. Use IN+ for active-low shutdown logic and IN- for active-high shutdown logic (see Figure 3). See Table 1 for all possible input combinations.

#### Driver Output

The MAX5078A/MAX5078B have low R<sub>DS(ON)</sub> p-channel and n-channel devices (totem pole) in the output stage for the fast turn-on/turn-off, high-gate-charge switching MOSFETs. The peak source or sink current is typically 4A. The output voltage (V<sub>OUT</sub>) is approximately equal to V<sub>DD</sub> when in high state and is ground when in low state. The driver R<sub>DS(ON)</sub> is lower at higher V<sub>DD</sub> resulting in higher source-/sink-current capability and faster switching speeds. The propagation delays from the noninverting and inverting logic inputs to OUT are matched to 2ns typically. The break-before-make logic avoids any cross-conduction between the internal p- and n-channel devices, and eliminates shoot-through, thus reducing the quiescent supply current.

### Applications Information

#### RLC Series Circuit

The driver's R<sub>DS(ON)</sub> (R<sub>ON</sub>), internal bond/lead inductance (L<sub>P</sub>), trace inductance (L<sub>S</sub>), gate inductance (L<sub>G</sub>), and gate capacitance (C<sub>G</sub>) form a series RLC circuit with a second-order characteristic equation. The series RLC circuit has an undamped natural frequency ( $\omega_0$ ) and a damping ratio ( $\xi$ ) where:

$$\omega_0 = \frac{1}{\sqrt{(L_P + L_S + L_G) \times C_G}}$$

$$\xi = \frac{R_{ON}}{2 \times \sqrt{\frac{(L_P + L_S + L_G)}{C_G}}}$$

The damping ratio needs to be greater than 0.5 (ideally 1) to avoid ringing. Add a small resistor (R<sub>GATE</sub>) in series with the gate when driving a very low gate-charge MOSFET, or when the driver is placed away from the MOSFET.

# MAX5078

## 4A, 20ns, MOSFET Driver

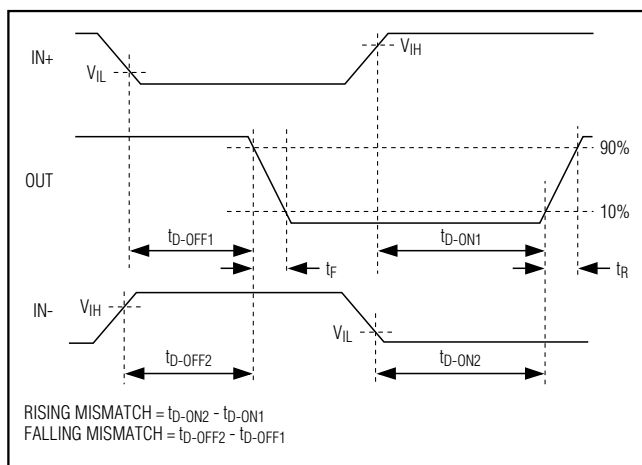

Figure 1. Timing Diagram

Use the following equation to calculate the series resistor:

$$R_{GATE} \geq \sqrt{\frac{(L_P + L_S + L_G)}{C_G}} - R_{ON}$$

$L_P$  can be approximated as 2nH for the TDFN package.  $L_S$  is on the order of 20nH/in. Verify  $L_G$  with the MOSFET vendor.

### Supply Bypassing and Grounding

Pay extra attention to bypassing and grounding the MAX5078A/MAX5078B. Peak supply and output currents may exceed 4A when driving large external capacitive loads. Supply voltage drops and ground shifts create negative feedback for inverters and may degrade the delay and transition times. Ground shifts due to poor device grounding may also disturb other circuits sharing the same AC ground return path. Any series inductance in the  $V_{DD}$ ,  $OUT$ , and/or  $GND$  paths can cause oscillations due to the very high di/dt when switching the MAX5078A/MAX5078B with any capacitive load. Place one or more 0.1 $\mu$ F ceramic capacitors in parallel as close to the device as possible to bypass  $V_{DD}$  to  $GND$ . Use a ground plane to minimize ground return resistance and series inductance. Place the external MOSFET as close as possible to the MAX5078A/MAX5078B to further minimize board inductance and AC path impedance.

### Power Dissipation

Power dissipation of the MAX5078A/MAX5078B consists of three components: caused by the quiescent current, capacitive charge/discharge of internal nodes, and the output current (either capacitive or resistive load). Maintain the sum of these components below the maximum power dissipation limit.

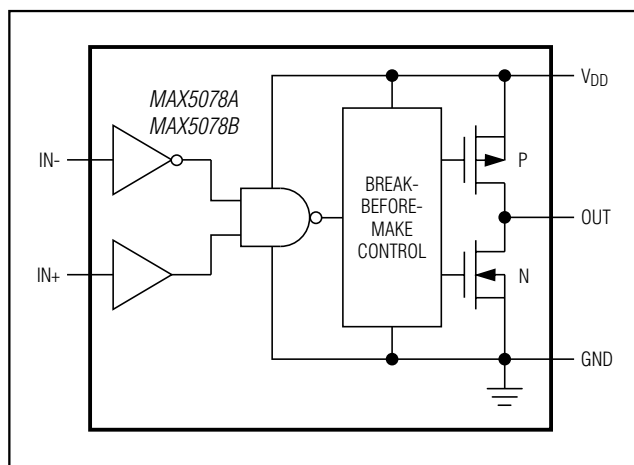

Figure 2. MAX5078 Simplified Diagram (1 Driver)

The current required to charge and discharge the internal nodes is frequency dependent (see the  $I_{DD-SW}$  Supply Current vs. Supply Voltage graph in the *Typical Operating Characteristics*). The power dissipation ( $P_Q$ ) due to the quiescent switching supply current ( $I_{DD-SW}$ ) can be calculated as:

$$P_Q = V_{DD} \times I_{DD-SW}$$

For capacitive loads, use the following equation to estimate the power dissipation:

$$P_{CLOAD} = C_{LOAD} \times (V_{DD})^2 \times f_{SW}$$

where  $C_{LOAD}$  is the capacitive load,  $V_{DD}$  is the supply voltage, and  $f_{SW}$  is the switching frequency.

Calculate the total power dissipation ( $P_T$ ) as follows:

$$P_T = P_Q + P_{CLOAD}$$

Use the following equations to estimate the MAX5078A/MAX5078B total power dissipation when driving a ground-referenced resistive load:

$$P_T = P_Q + P_{RLOAD}$$

$$P_{RLOAD} = D \times R_{ON(MAX)} \times I_{LOAD}^2$$

where  $D$  is the fraction of the period the MAX5078A/MAX5078B's output pulls high,  $R_{ON(MAX)}$  is the maximum on-resistance of the device with the output high, and  $I_{LOAD}$  is the output load current of the MAX5078A/MAX5078B.

### Layout Information

The MAX5078A/MAX5078B MOSFET drivers source and sink large currents to create very fast rising and falling edges at the gate of the switching MOSFET. The high di/dt can cause unacceptable ringing if the trace lengths and impedances are not well controlled.

# MAX5078

## 4A, 20ns, MOSFET Driver

**Table 1. MAX5078 Truth Table**

IN+	IN-	OUT
Low	Low	Low
Low	High	Low
High	Low	High
High	High	Low

Use the following PC board layout guidelines when designing with the MAX5078A/MAX5078B:

- Place one or more 0.1 $\mu$ F decoupling ceramic capacitors from V<sub>DD</sub> to GND as close to the device as possible. Connect V<sub>DD</sub> and GND to large copper areas. Place one bulk capacitor of 10 $\mu$ F (min) on the PC board with a low resistance path to the V<sub>DD</sub> input and GND of the MAX5078A/MAX5078B.
- Two AC current loops form between the device and the gate of the driven MOSFET. The MOSFET looks like a large capacitance from gate to source when the gate pulls low. The active current loop is from the MOSFET gate to OUT of the MAX5078A/MAX5078B, to GND of the MAX5078A/MAX5078B, and to the source of the MOSFET. When the gate of the MOSFET pulls high, the active current is from the V<sub>DD</sub> terminal of the decoupling capacitor, to V<sub>DD</sub> of the MAX5078A/MAX5078B, to OUT of the MAX5078A/MAX5078B, to the MOSFET gate, to the MOSFET source, and to the negative terminal of the decoupling capacitor. Both charging current and discharging current loops are important. Minimize the physical distance and the impedance in these AC current paths.
- Keep the device as close to the MOSFET as possible.
- In a multilayer PC board, the inner layers should consist of a GND plane containing the discharging and charging current loops.
- Pay extra attention to the ground loop and use a low-impedance source when using a TTL logic-input device. Fast fall time at OUT may corrupt the input during transition.

### Exposed Pad

The TDFN-EP package has an exposed pad on the bottom of its package. This pad is internally connected to GND. For the best thermal conductivity, solder the exposed pad to the ground plane in order to dissipate 1.9W. Do not use the ground-connected pad as the only electrical ground connection or ground return. Use GND (pins 2 and 3) as the primary electrical ground connection.

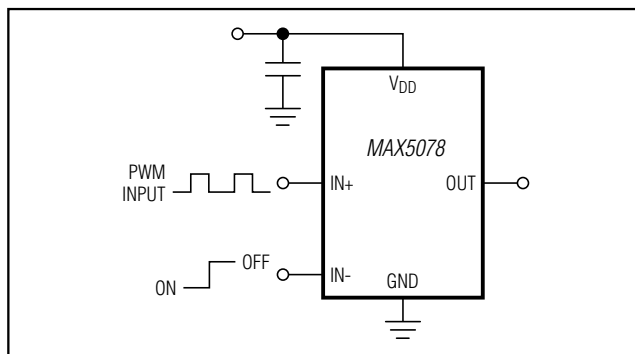

Figure 3. Unused Input as an ON/OFF Function

### Additional Application Circuits

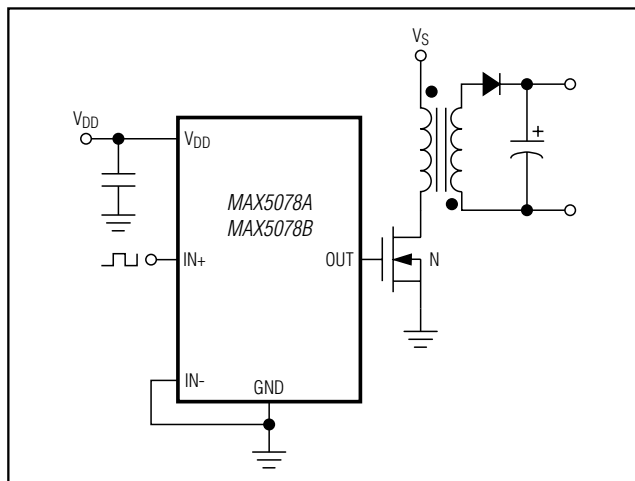

Figure 4. Noninverting Application

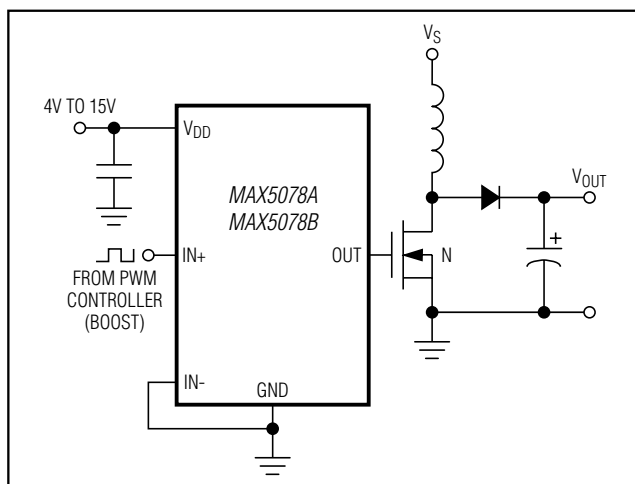

Figure 5. Boost Converter



# **MAX5078**

## **4A, 20ns, MOSFET Driver**

---

### **Chip Information**

PROCESS: CMOS

---

### **Package Information**

For the latest package outline information and land patterns (footprints), go to [www.maximintegrated.com/packages](http://www.maximintegrated.com/packages). Note that a "+", "#", or "-" in the package code indicates RoHS status only. Package drawings may show a different suffix character, but the drawing pertains to the package regardless of RoHS status.

<b>PACKAGE TYPE</b>	<b>PACKAGE CODE</b>	<b>OUTLINE NO.</b>	<b>LAND PATTERN NO.</b>
6 TDFN-EP	T633+2	<a href="#">21-0137</a>	<a href="#">90-0058</a>

# MAX5078

## 4A, 20ns, MOSFET Driver

### Revision History

REVISION NUMBER	REVISION DATE	DESCRIPTION	PAGES CHANGED
2	9/12	Added automotive qualified parts to <i>Ordering Information</i>	1



Maxim cannot assume responsibility for use of any circuitry other than circuitry entirely embodied in a Maxim product. No circuit patent licenses are implied. Maxim reserves the right to change the circuitry and specifications without notice at any time. The parametric values (min and max limits) shown in the Electrical Characteristics table are guaranteed. Other parametric values quoted in this data sheet are provided for guidance.

## Looking for pricing, stock, or lifecycle information?

Click below to explore more details on WIN SOURCE:

- ⊖ [View MAX5078BATT+T on WIN SOURCE](#)
- ⊖ [Maxim Integrated Information](#)

## Optimize Your Supply Chain with WIN SOURCE Solutions

- ✓ Global Sourcing Solution
- ✓ Obsolete Management
- ✓ Cost Control Management
- ✓ Shortage Management
- ✓ Alternative Solution
- ✓ Excess Inventory Management