



**THE DATASHEET OF
MAX5116EEE+**



Nonvolatile, Quad, 8-Bit DACs with 2-Wire Serial Interface

General Description

The MAX5115/MAX5116 quad, 8-bit, digital-to-analog converters (DACs) feature nonvolatile registers. These nonvolatile registers store the DAC operating modes and output states, allowing the DACs to initialize to specified configurations at power-up.

Precision on-chip output buffers swing rail-to-rail, and provide 8 μ s settling time. The I²C-compatible, 2-wire serial interface allows for a maximum clock frequency of 400kHz.

The MAX5115 has independent high and low reference inputs allowing maximum output voltage range flexibility. The MAX5116 has single high and low reference inputs for all DACs to minimize trace count and save board space. The reference rails accept voltage inputs that range from ground to the positive supply rail.

The devices operate from a single +2.7V to +5.25V supply and consume 200 μ A per DAC. A software-controlled power-down mode decreases supply current to less than 25 μ A. A software-controlled mute mode sets each DAC, or both DACs simultaneously, to their respective REFL_ voltages. The MAX5116 also includes an asynchronous MUTE input, that drives all DAC outputs simultaneously to their respective REFL_ voltages.

The MAX5115 is available in a 20-pin QSOP, and the MAX5116 is available in a 16-pin QSOP package. Both devices are specified for operation over the extended (-40°C to +85°C) temperature range.

Applications

- Digital Gain and Offset Adjustments
- Programmable Attenuators
- Portable Instruments
- Power-Amp Bias Control
- ATE Calibration
- Laser Biasing

Pin Configuration and Typical Operating Circuit appear at end of data sheet.

Features

- ◆ Nonvolatile Registers Initialize DACs to Stored States
- ◆ +2.7V to +5.25V Single-Supply Operation
- ◆ Quad 8-Bit DACs with Independent High and Low Reference Inputs
- ◆ Rail-to-Rail Output Buffers
- ◆ Low 200 μ A per DAC Supply Current
- ◆ Power-Down Mode Reduces Supply Current to 25 μ A (max)
- ◆ 400kHz, I²C-Compatible, 2-Wire Serial Interface
- ◆ Asynchronous MUTE Input (MAX5116)
- ◆ Small 16-/20-Pin QSOP Packages

Ordering Information

PART	TEMP RANGE	PIN-PACKAGE	REFERENCE INPUTS
MAX5115EEP	-40°C to +85°C	20 QSOP	4
MAX5116EEE	-40°C to +85°C	16 QSOP	1

Simplified Diagram

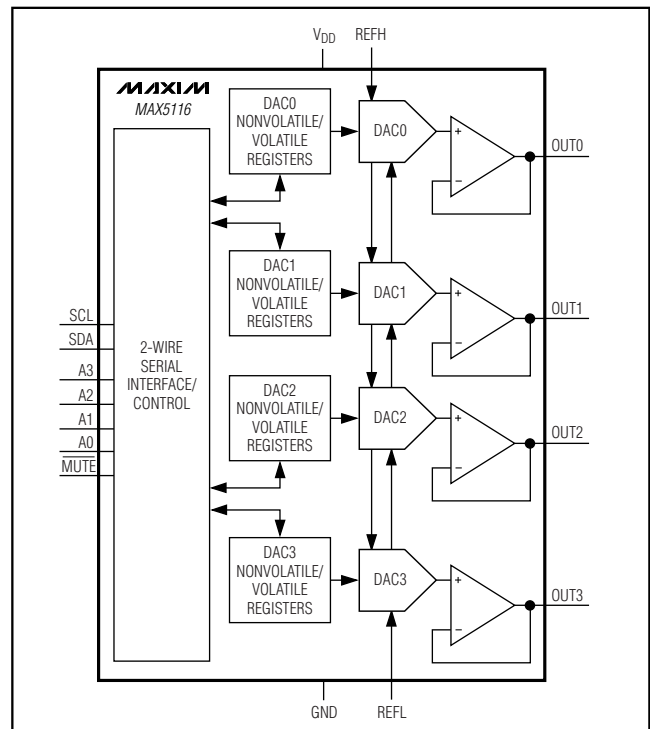

Nonvolatile, Quad, 8-Bit DACs with 2-Wire Serial Interface

ABSOLUTE MAXIMUM RATINGS

(All voltages referenced to GND, unless otherwise noted.)

V _{DD} , A0, A1, A2, A3, SCL, SDA, MUTE	-0.3V to +6.0V
OUT0, OUT1, OUT2, OUT3, REFH0, REFH1, REFH2, REFH3, REFH, REFL0, REFL1, REFL2, REFL3, REFL	-0.3V to (V _{DD} + 0.3V)
Maximum Current into Any Pin	±50mA

Power Dissipation (T_A = +70°C)

16-Pin QSOP (derate 8.3mW/°C above +70°C)	667mW
20-Pin QSOP (derate 9.1mW/°C above +70°C)	727mW
Operating Temperature Range	-40°C to +85°C
Junction Temperature	+150°C
Storage Temperature Range	-60°C to +150°C
Lead Temperature (soldering, 10s)	+300°C

Stresses beyond those listed under "Absolute Maximum Ratings" may cause permanent damage to the device. These are stress ratings only, and functional operation of the device at these or any other conditions beyond those indicated in the operational sections of the specifications is not implied. Exposure to absolute maximum rating conditions for extended periods may affect device reliability.

ELECTRICAL CHARACTERISTICS

(V_{DD} = +2.7V to +5.25V, GND = 0, REFH₋ = V_{DD}, REFL₋ = GND, R_{LOAD} = 5kΩ, C_L = 100pF, T_A = -40°C to +85°C, unless otherwise noted. Typical values are at V_{DD} = +3.0V and T_A = +25°C.) (Note 1)

PARAMETER	SYMBOL	CONDITIONS	MIN	TYP	MAX	UNITS
STATIC ACCURACY						
Resolution			8			Bits
Integral Nonlinearity	INL	Code range 0A hex to F0 hex			±1	LSB
		Full code range		±2		
Differential Nonlinearity (Note 2)	DNL	Code range 0A hex to F0 hex			±0.5	LSB
		Full code range		±1		
Offset Error	ZCE	Code = 0A hex			±20	mV
Offset Temperature Coefficient		Code = 0A hex		±20		μV/°C
Gain Error		Code = F0 hex (Note 3)			±1	LSB
Gain-Error Temperature Coefficient		Code = F0 hex		±0.002		LSB/°C
Power-Supply Rejection Ratio	PSRR	Code = FF hex or 0A hex, V _{REFH-} = 2.5V, V _{REFL-} = 0, f = DC			1	LSB/V
REFERENCE INPUT (REFH₋, REFL₋, REFH, REFL)						
Input Voltage Range	V _{REFH-} , V _{REFL-}	V _{REFH-} ≥ V _{REFL-}	0		V _{DD}	V
Input Resistance		MAX5115	320	460	600	kΩ
		MAX5116	80	115	150	
Input-Resistance Temperature Coefficient				±35		ppm/°C
Input Capacitance				10		pF
DAC OUTPUTS (OUT₋)						
Load Regulation		Code = F0 hex, R _{LOAD} ≥ 5kΩ		±0.5	±1	LSB
Output Leakage		DAC powered down, not muted			±10	μA
Amplifier Output Resistance		0.5V ≤ V _{OUT-} ≤ (V _{DD} - 0.5V)		0.5		Ω
DIGITAL INPUTS (A₋, MUTE)						
Input High Voltage (Note 4)	V _{IH}	2.7V ≤ V _{DD} < 3.6V	0.7 x			V
		3.6V ≤ V _{DD} ≤ 5.25V	V _{DD}	2.52		

Nonvolatile, Quad, 8-Bit DACs with 2-Wire Serial Interface

MAX5115/MAX5116

ELECTRICAL CHARACTERISTICS (continued)

($V_{DD} = +2.7V$ to $+5.25V$, $GND = 0$, $REFH_{-} = V_{DD}$, $REFL_{-} = GND$, $R_{LOAD} = 5k\Omega$, $C_L = 100pF$, $T_A = -40^{\circ}C$ to $+85^{\circ}C$, unless otherwise noted. Typical values are at $V_{DD} = +3.0V$ and $T_A = +25^{\circ}C$.) (Note 1)

PARAMETER	SYMBOL	CONDITIONS	MIN	TYP	MAX	UNITS
Input Low Voltage (Note 4)	V_{IL}	$2.7V \leq V_{DD} < 3.6V$			$0.3 \times V_{DD}$	V
		$3.6V \leq V_{DD} \leq 5.25V$			1.1	
Input Hysteresis	V_{HYS}			$0.05 \times V_{DD}$		V
Input Leakage Current	I_{IN}	$V_{IN} = 0$ or V_{DD}			± 1	μA
Input Capacitance	C_{IN}			10		pF
DIGITAL OUTPUT (SDA)						
Output Low Voltage	V_{OL}	$I_{SINK} = 3mA$			0.4	V
		$I_{SINK} = 6mA$			0.6	
Tri-State Leakage	I_L				± 1	μA
Tri-State Output Capacitance	C_{OUT}			15		pF
DYNAMIC PERFORMANCE						
SCL to OUT_ Settling	t_{COS}	(Note 5)		8		μs
Crosstalk		(Note 6)		55		dB
Multiplying Signal-to-Noise Plus Distortion	SINAD	$V_{REFH_{-}} = 2.5V_{P-P}$ at 1kHz		65		dB
		$V_{REFH_{-}} = 2.5V_{P-P}$ at 10kHz		52		
Multiplying Bandwidth		$V_{REFH_{-}} = 0.5V_{P-P}$, 3dB bandwidth		325		kHz
Reference Feedthrough		$V_{REFH_{-}} = 2.5V_{P-P}$ at 10kHz (Note 7)		88		dB
Clock Feedthrough				2.5		nVs
Output Noise	e_N			800		nV/\sqrt{Hz}
Power-Up Time	t_{SDR}	From power-down state		4		μs
Power-Down Time	t_{SDN}			1.5		μs
INTERFACE PORTS (SCL, SDA)						
Input Voltage	V_{IL}				$0.3 \times V_{DD}$	V
	V_{IH}			$0.7 \times V_{DD}$		
Input Hysteresis	V_{HYS}			$0.05 \times V_{DD}$		V
Input Current	I_{IN}				± 1	μA
Input Capacitance	C_{IN}			5		pF
POWER SUPPLIES						
Power-Supply Voltage	V_{DD}		2.70		5.25	V
Supply Current	I_{DD}	$I_{LOAD} = 0$, digital inputs at GND or V_{DD}	Normal operation	0.8	1.3	mA
			During nonvolatile write		2	
Power-Down Current					25	μA

Nonvolatile, Quad, 8-Bit DACs with 2-Wire Serial Interface

ELECTRICAL CHARACTERISTICS (continued)

($V_{DD} = +2.7V$ to $+5.25V$, $GND = 0$, $REFH_{-} = V_{DD}$, $REFL_{-} = GND$, $R_{LOAD} = 5k\Omega$, $C_L = 100pF$, $T_A = -40^{\circ}C$ to $+85^{\circ}C$, unless otherwise noted. Typical values are at $V_{DD} = +3.0V$ and $T_A = +25^{\circ}C$.) (Note 1)

PARAMETER	SYMBOL	CONDITIONS	MIN	TYP	MAX	UNITS
DIGITAL TIMING (Figure 4, Note 8)						
SCL Clock Frequency	f_{SCL}				400	kHz
Setup Time for START Condition	$t_{SU:STA}$		0.6			μs
Hold Time for START Condition	$t_{HD:STA}$		0.6			μs
SCL High Time	t_{HIGH}		0.6			μs
SCL Low Time	t_{LOW}		1.3			μs
Data Setup Time	$t_{SU:DAT}$		100			ns
Data Hold Time	$t_{HD:DAT}$		0		0.9	μs
SDA, SCL Rise Time	t_R				300	ns
SDA, SCL Fall Time	t_F				300	ns
Setup Time for STOP Condition	$t_{SU:STO}$		0.6			μs
Bus Free Time Between a STOP and START Condition	t_{BUF}		1.3			μs
Pulse Width of Spike Suppressed	t_{SP}				50	ns
Maximum Capacitive Load for Each Bus Line	C_B	(Note 9)		400		pF
Write NV Register Busy Time		(Note 10)			15	ms
NONVOLATILE MEMORY RELIABILITY						
Data Retention		$T_A = +85^{\circ}C$		50		Years
Endurance		$T_A = +25^{\circ}C$		200,000		Stores
		$T_A = +85^{\circ}C$		50,000		

Note 1: All devices are 100% production tested at $T_A = +25^{\circ}C$. All temperature limits are guaranteed by design.

Note 2: Guaranteed monotonic.

Note 3: Gain error is defined as:

$$\frac{256 \times (V_{F0,Meas} - ZCE - V_{F0,Ideal})}{V_{REFH_{-}}}$$

where $V_{F0,Meas}$ is the DAC voltage with input code F0 hex and $V_{F0,Ideal}$ is the ideal DAC voltage with input code F0 hex or $(V_{REFH_{-}} - V_{REFL_{-}}) \times (240 / 256) + V_{REFL_{-}}$.

Note 4: The device draws higher supply current when the digital inputs are driven with voltages between $(V_{DD} - 0.5V)$ and $(GND + 0.5V)$. See Supply Current vs. Digital Input Voltage in the *Typical Operating Characteristics*.

Note 5: Output settling time is measured from the 50% point of the rising edge of the last SCL of the data byte to 0.5 LSB of OUT_{-} 's final value for a code transition from 10 hex to F0 hex.

Note 6: Crosstalk is defined as the coupling from a DAC switching from code 00 hex to code FF hex to any other DAC that is in a steady state at code 00 hex.

Note 7: Reference feedthrough is defined as the coupling from one driven reference with input code = FF hex to any other DAC output with the reference of the DAC at a constant value and input code = 00 hex.

Note 8: SCL clock period includes rise and fall times t_R and t_F . All digital input signals are specified with $t_R = t_F = 2ns$ and timed from a voltage level of $(V_{IL} + V_{IH}) / 2$.

Note 9: An appropriate bus pullup resistance must be selected depending on board capacitance. Refer to the document linked to this web address: www.semiconductors.philips.com/acrobat/literature/9398/39340011.pdf.

Note 10: The busy time begins from the initiation of the stop pulse.

Nonvolatile, Quad, 8-Bit DACs with 2-Wire Serial Interface

Typical Operating Characteristics

($V_{DD} = +3V$, $V_{REFH_} = +3V$, $V_{REFL_} = GND$, $R_L = 5k\Omega$, $C_L = 100pF$, $T_A = +25^\circ C$, unless otherwise noted.)

MAX5115/MAX5116

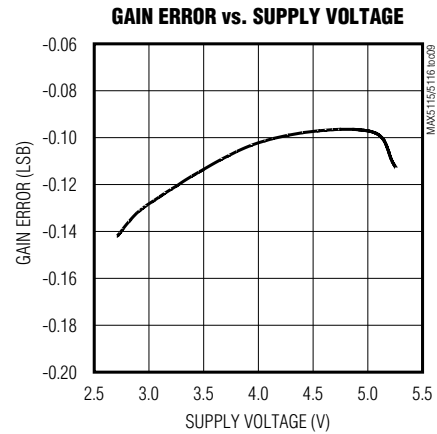
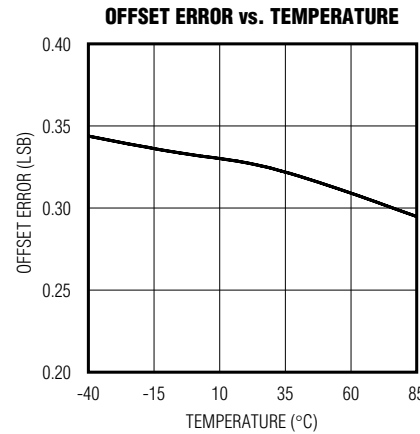
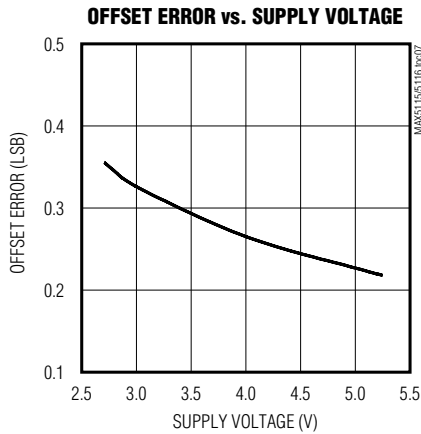
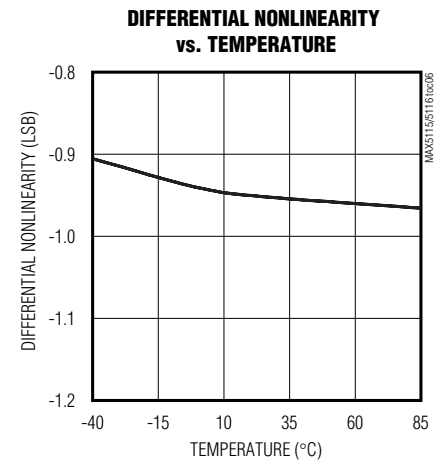
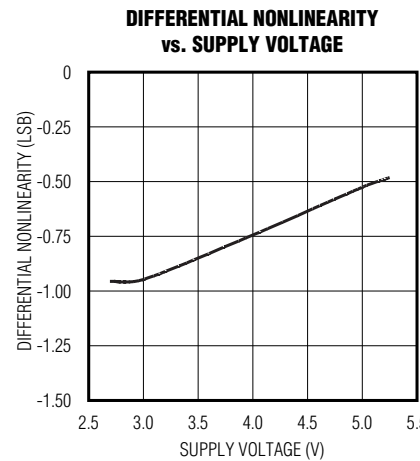
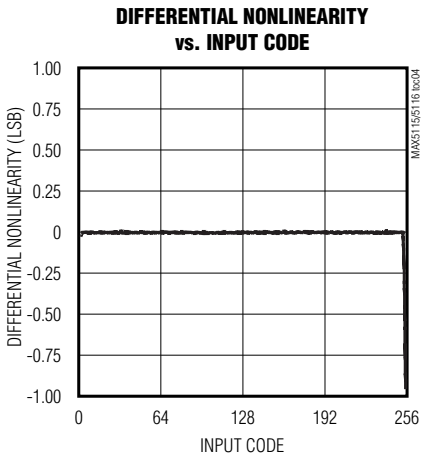
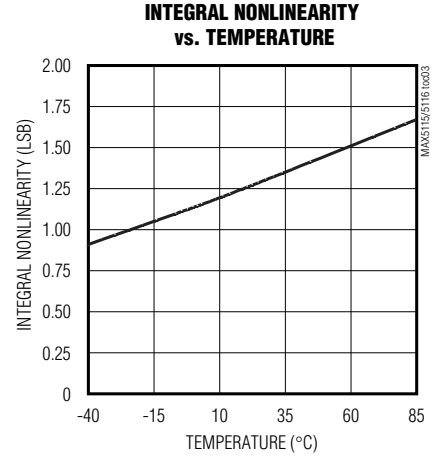
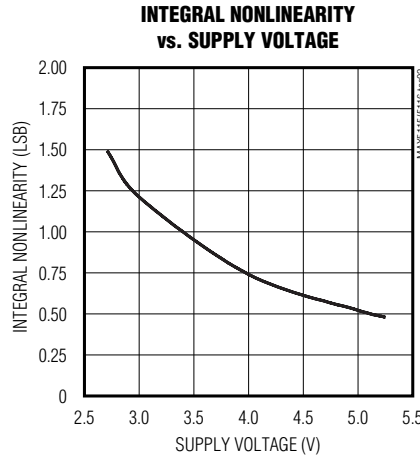
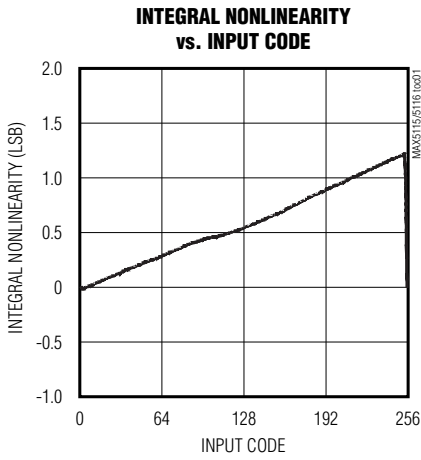

Nonvolatile, Quad, 8-Bit DACs with 2-Wire Serial Interface

Typical Operating Characteristics (continued)

($V_{DD} = +3V$, $V_{REFH} = +3V$, $V_{REFL} = GND$, $R_L = 5k\Omega$, $C_L = 100pF$, $T_A = +25^\circ C$, unless otherwise noted.)

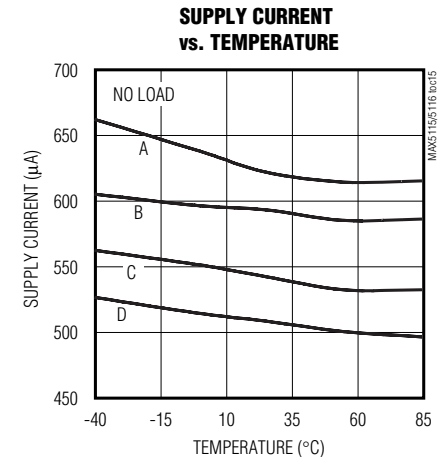
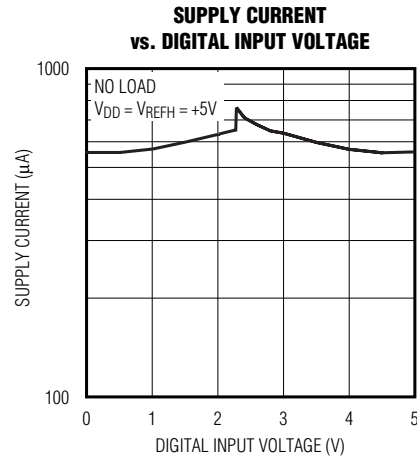
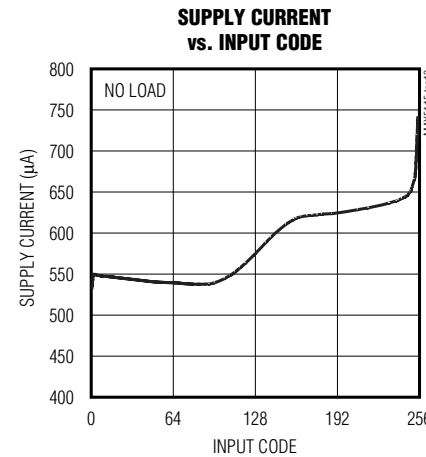
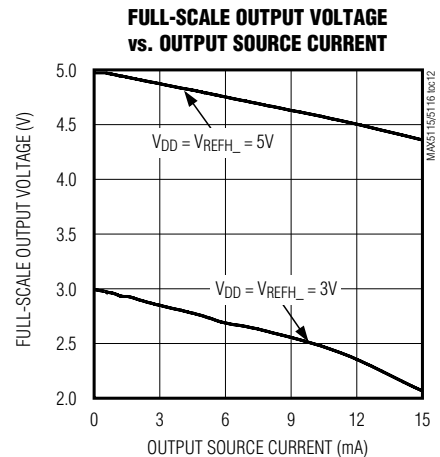
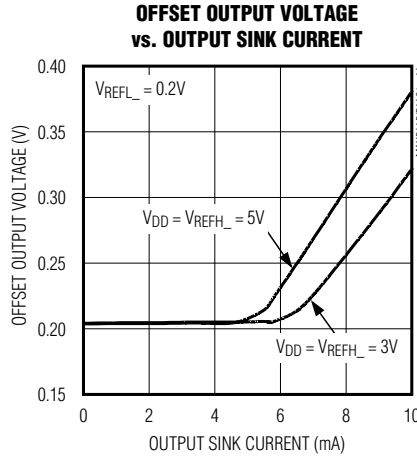
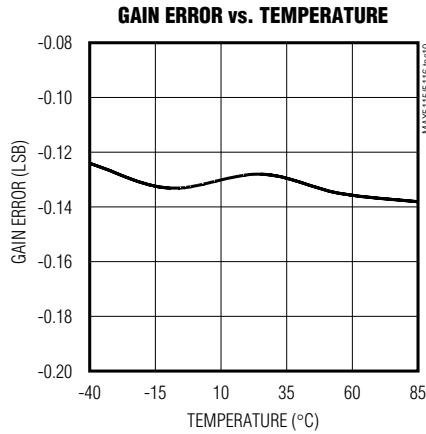

A: $V_{DD} = 5V$, $V_{REFH} = 4.096V$, CODE = FFh
 B: $V_{DD} = 5V$, $V_{REFH} = 4.096V$, CODE = 00h
 C: $V_{DD} = 3V$, $V_{REFH} = 2.5V$, CODE = FFh
 D: $V_{DD} = 3V$, $V_{REFH} = 2.5V$, CODE = 00h

Nonvolatile, Quad, 8-Bit DACs with 2-Wire Serial Interface

Typical Operating Characteristics (continued)

($V_{DD} = +3V$, $V_{REFH_} = +3V$, $V_{REFL_} = GND$, $R_L = 5k\Omega$, $C_L = 100pF$, $T_A = +25^\circ C$, unless otherwise noted.)

MAX5115/MAX5116

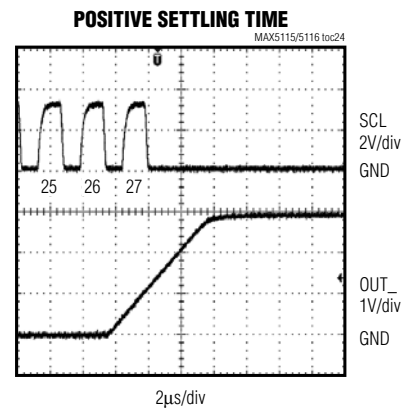
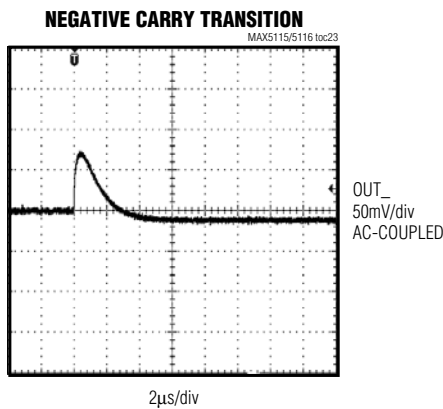
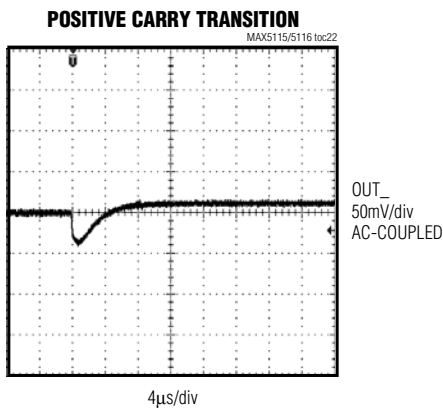
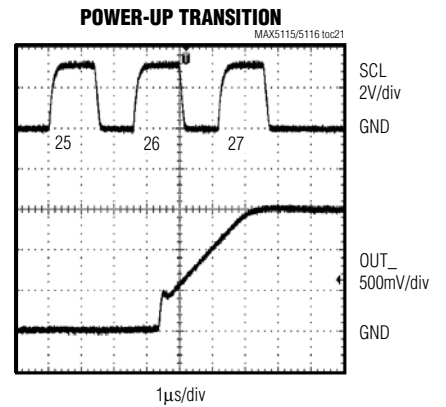
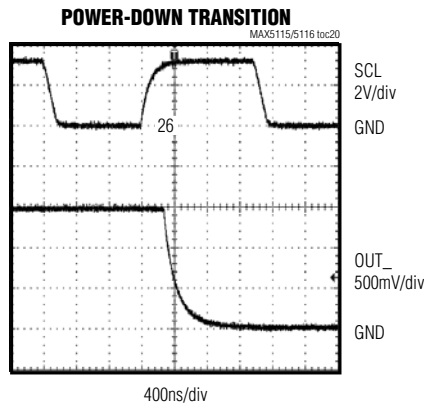
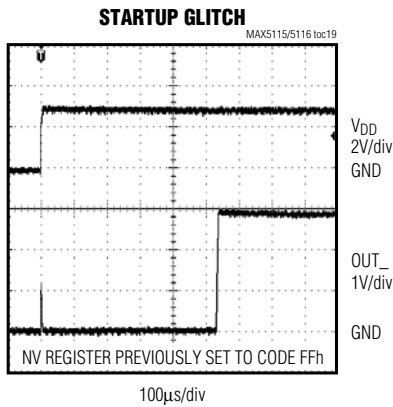
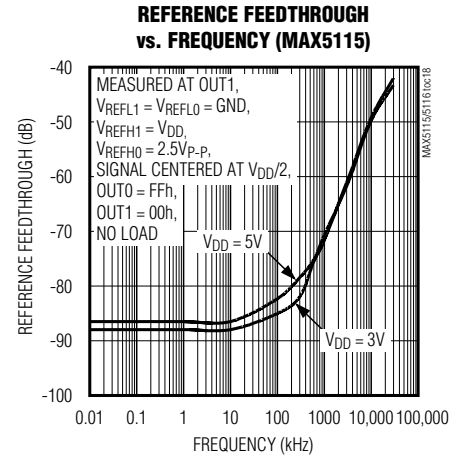
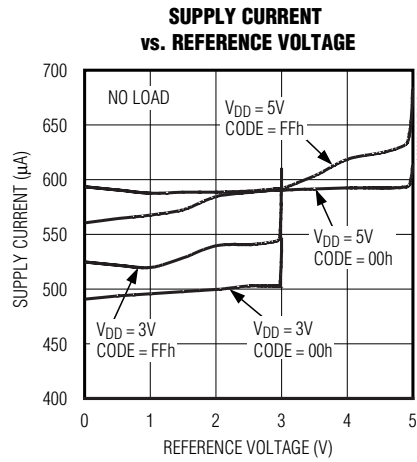
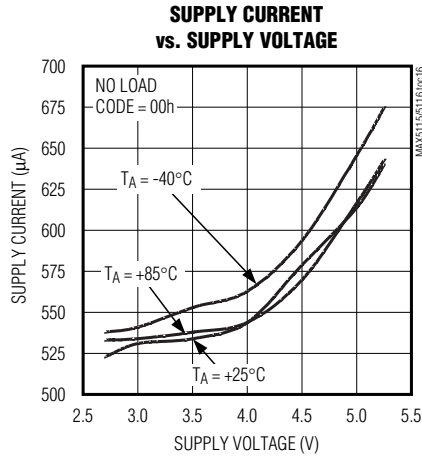

Nonvolatile, Quad, 8-Bit DACs with 2-Wire Serial Interface

Typical Operating Characteristics (continued)

($V_{DD} = +3V$, $V_{REFH_} = +3V$, $V_{REFL_} = GND$, $R_L = 5k\Omega$, $C_L = 100pF$, $T_A = +25^\circ C$, unless otherwise noted.)

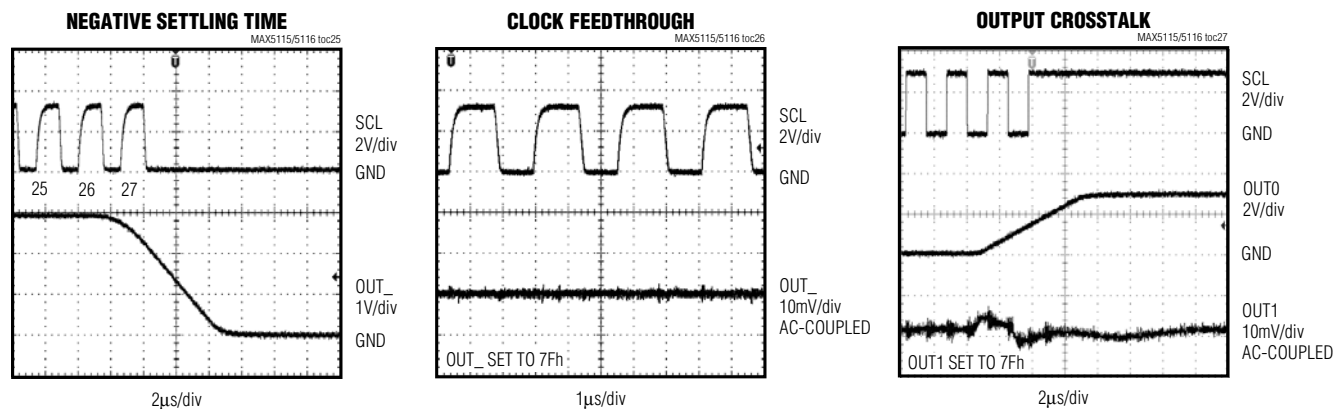

Pin Description

PIN		NAME	FUNCTION
MAX5115	MAX5116		
1	2	A2	Address Select 2. Connect to V_{DD} or GND to set the device address.
2	3	A1	Address Select 1. Connect to V_{DD} or GND to set the device address.
3	4	A0	Address Select 0. Connect to V_{DD} or GND to set the device address.
4	—	REFH1	DAC1 High Reference Input. REFH1 must be equal to or greater than REFL1.
5	—	REFL1	DAC1 Low Reference Input. REFL1 must be equal to or less than REFH1.
6	6	OUT1	DAC1 Output. OUT1 is buffered with a unity-gain amplifier.
7	—	REFH2	DAC2 High Reference Input. REFH2 must be equal to or greater than REFL2.
8	—	REFL2	DAC2 Low Reference Input. REFL2 must be equal to or less than REFH2.
9	7	OUT2	DAC2 Output. OUT2 is buffered with a unity-gain amplifier.
10	8	GND	Ground
11	10	OUT3	DAC3 Output. OUT3 is buffered with a unity-gain amplifier.
12	—	REFL3	DAC3 Low Reference Input. REFL3 must be equal to or less than REFH3.
13	—	REFH3	DAC3 High Reference Input. REFH3 must be equal to or greater than REFL3.
14	11	OUT0	DAC0 Output. OUT0 is buffered with a unity-gain amplifier.
15	—	REFL0	DAC0 Low Reference Input. REFL0 must be equal to or less than REFH0.
16	—	REFH0	DAC0 High Reference Input. REFH0 must be equal to or greater than REFL0.
17	14	SCL	Serial-Clock Input. Connect SCL to V_{DD} through a $2.4k\Omega$ pullup resistor.
18	15	V_{DD}	Positive-Power Input. Connect V_{DD} to a +2.7 to +5.25V power supply. Bypass V_{DD} to GND with a $0.1\mu F$ capacitor as close to the device as possible.
19	16	SDA	Serial Data Input/Output. Connect SDA to V_{DD} through a $2.4k\Omega$ pullup resistor.
20	1	A3	Address Select 3. Connect to V_{DD} or GND to set the device address.
—	5	N.C.	No Connection. Not internally connected.
—	9	\overline{MUTE}	Active-Low Mute Input. Connect \overline{MUTE} low to drive all DAC outputs to their respective reference low voltages. Connect \overline{MUTE} to V_{DD} for normal operation.
—	12	REFL	DAC Low Reference Input. REFL must be equal to or less than REFH.
—	13	REFH	DAC High Reference Input. REFH must be equal to or greater than REFL.

Nonvolatile, Quad, 8-Bit DACs with 2-Wire Serial Interface

MAX5115/MAX5116

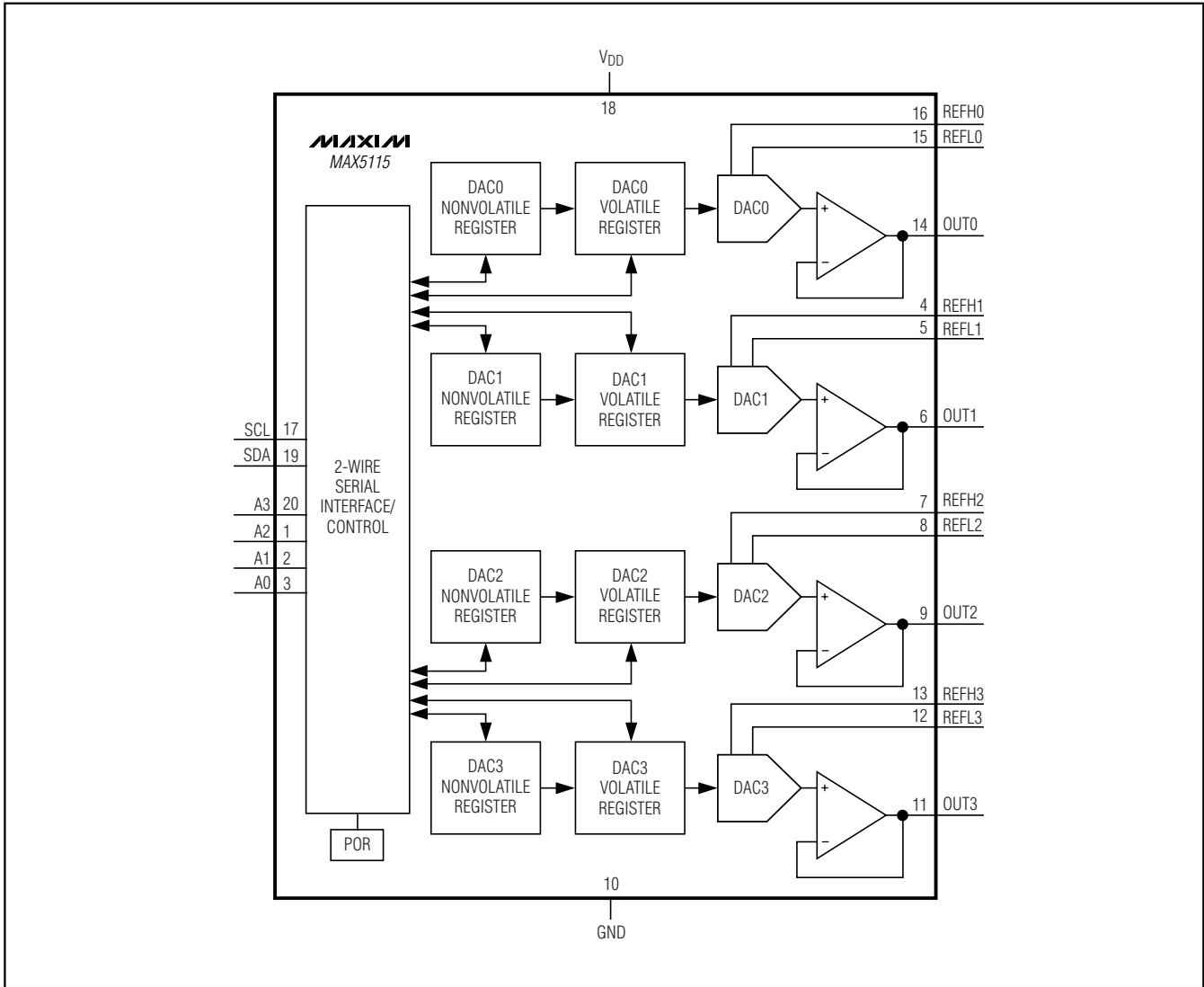

Figure 1. MAX5115 Functional Diagram

Nonvolatile, Quad, 8-Bit DACs with 2-Wire Serial Interface

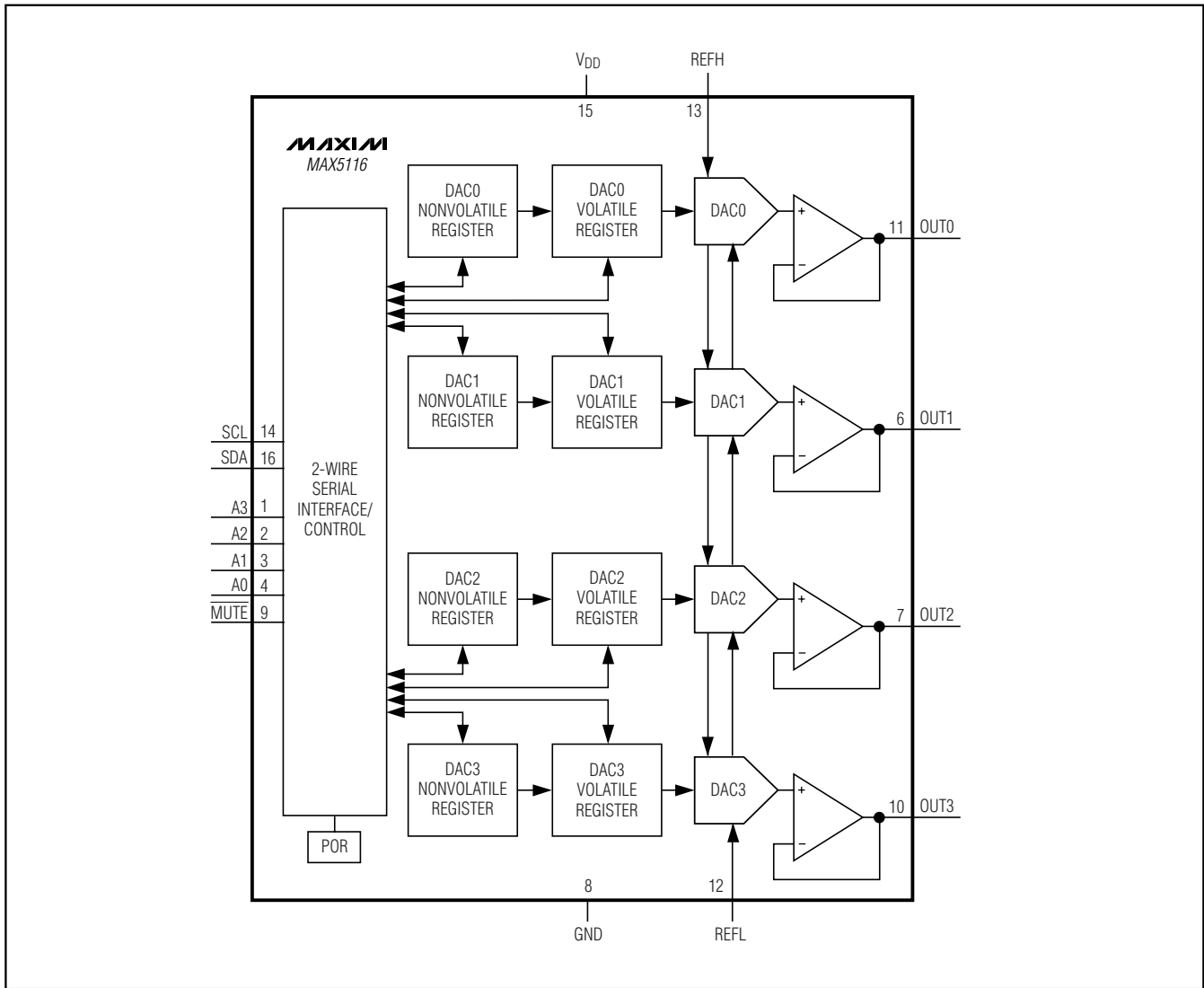

Figure 2. MAX5116 Functional Diagram

Nonvolatile, Quad, 8-Bit DACs with 2-Wire Serial Interface

MAX5115/MAX5116

Detailed Description

The MAX5115/MAX5116 8-bit DACs feature internal, nonvolatile registers that store the DAC states for initialization during power-up. These devices consist of resistor-string DACs, rail-to-rail output buffers, a shift register, power-on reset (POR) circuitry, and volatile and nonvolatile memory registers (Figures 1 and 2). The shift register decodes the control and address bits, routing the data to the proper registers. Writing data to a selected volatile register immediately updates the DAC outputs.

The volatile registers retain data as long as the device is powered. Removing power clears the volatile registers. The nonvolatile registers retain data even after power is removed. On startup, when power is first applied, data from the nonvolatile registers is transferred to the volatile registers to automatically initialize the device. Read data from the nonvolatile or volatile registers using the 2-wire serial interface.

DAC Operation

The MAX5115/MAX5116 use a DAC matrix decoding architecture that saves power. A resistor string divides the difference between the external reference voltages, V_{REFH} and V_{REFL} . Row and column decoders select the appropriate tap from the resistor string, providing the equivalent analog voltage. The resistor string presents a code-independent input impedance to the reference and guarantees a monotonic output. Figure 3 shows a simplified diagram of one DAC.

Output Buffer Amplifiers

The MAX5115/MAX5116 analog outputs are internally buffered by a precision unity-gain amplifier. The outputs swing from GND to V_{DD} with a V_{REFL} -to- V_{REFH} output transition. The amplifier outputs typically settle to ± 0.5 LSB in 8 μ s when loaded with 5k Ω in parallel with 100pF.

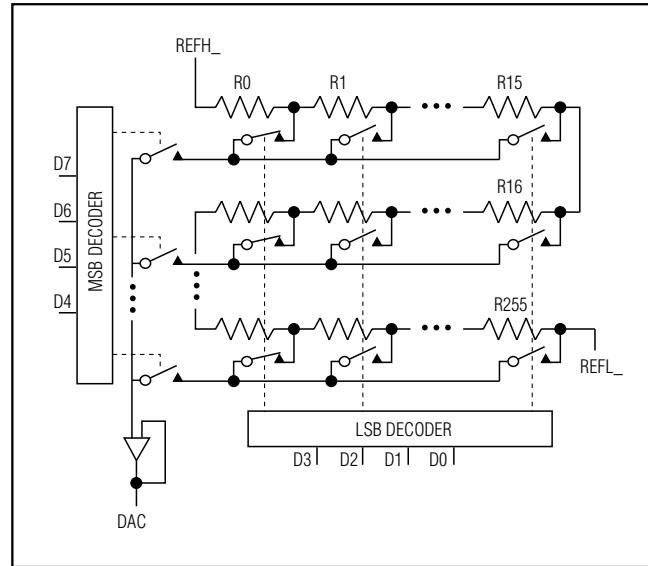

Figure 3. DAC Simplified Circuit Diagram

DAC Registers

The MAX5115/MAX5116 feature two registers per DAC, a volatile and a nonvolatile register, that store the DAC data. The volatile DAC register holds the current value of each DAC. Write data to the volatile registers directly from the 2-wire serial interface or by loading the previously stored data from the respective nonvolatile register. Clear the volatile registers by removing power to the device. The volatile registers are read/write.

The nonvolatile register retains the DAC values even after power is removed. Read stored data using the 2-wire serial interface. On power-up, the devices automatically initialize with data stored in the nonvolatile registers. The nonvolatile registers are read/write and programmed to all zeros at the factory.

Nonvolatile, Quad, 8-Bit DACs with 2-Wire Serial Interface

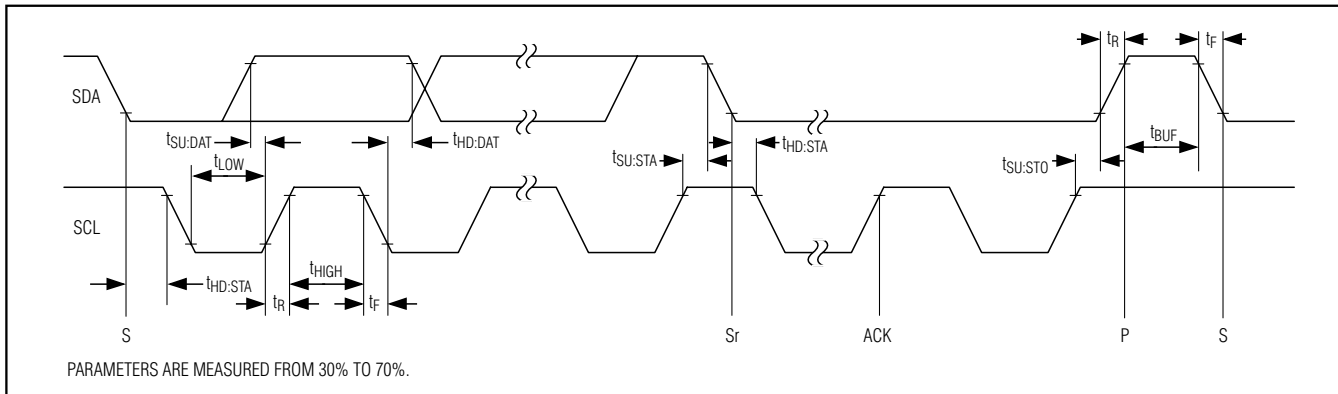

Figure 4. 2-Wire Serial-Interface Timing Diagram

Serial Interface

The MAX5115/MAX5116 feature an I²C-compatible, 2-wire serial interface consisting of a bidirectional serial data line (SDA) and a serial clock line (SCL). SDA and SCL facilitate bidirectional communication between the MAX5115/MAX5116 and the master at rates up to 400kHz (Figure 4). The master (typically a microcontroller) initiates data transfer on the bus and generates SCL. SDA and SCL require pullup resistors (2.4k Ω or greater; see the *Typical Operating Circuit*). Optional resistors (24 Ω) in series with SDA and SCL protect the device inputs from high-voltage spikes on the bus lines. Series resistors also minimize crosstalk and undershoot of the bus signals.

I²C Compatibility

The MAX5115/MAX5116 are compatible with existing I²C systems. SCL and SDA are high-impedance inputs; SDA has an open-drain output. The *Typical Operating Circuit* shows an I²C application. The communication protocol supports standard I²C 8-bit communications. The general call address is ignored, and CBUS formats are not supported. The devices' addresses are compatible with 7-bit I²C addressing protocol only. No 10-bit address formats are supported.

Bit Transfer

One data bit transfers during each SCL rising edge. Nine clock cycles are required to transfer the data into or out of the MAX5115/MAX5116. The data on SDA must remain stable during the high period of the SCL clock pulse. Changes in SDA while SCL is high are read as control signals (see the *START and STOP Conditions* section). Both SDA and SCL idle high.

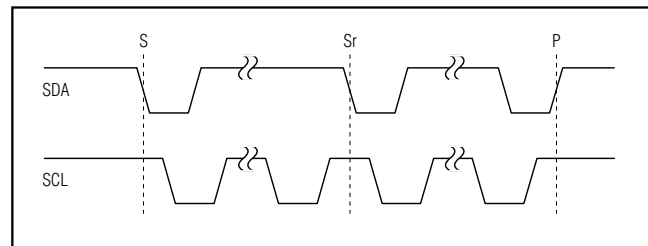

Figure 5. START and STOP Conditions

START and STOP Conditions

The master initiates a transmission with a START condition (S), a high-to-low transition on SDA with SCL high. The master terminates a transmission with a STOP condition (P), a low-to-high transition on SDA while SCL is high (Figure 5). A START condition from the master signals the beginning of a transmission to the MAX5115/MAX5116. The master terminates transmission by issuing a STOP condition. The STOP condition frees the bus. If a REPEATED START condition (Sr) is generated instead of a STOP condition, the bus remains active.

Early STOP Conditions

The MAX5115/MAX5116 recognize a STOP condition at any point during transmission except if a STOP condition occurs in the same high pulse as a START condition (Figure 6). This condition is not a legal I²C format.

REPEATED START Conditions

A REPEATED START (Sr) condition is used when the bus master is writing to several I²C devices and does not want to relinquish control of the bus. The MAX5115/MAX5116 serial interface supports continuous write operations with an Sr condition separating them. Continuous read operations require Sr conditions because of the change in direction of data flow.

Nonvolatile, Quad, 8-Bit DACs with 2-Wire Serial Interface

Acknowledge Bit (ACK) and Not-Acknowledge Bit (NACK)

Successful data transfers are acknowledged with an acknowledge bit (ACK) or a not-acknowledge bit (NACK). Both the master and the MAX5115/MAX5116 (slave) generate acknowledge bits. To generate an acknowledge, the receiving device must pull SDA low before the rising edge of the acknowledge-related clock pulse (ninth pulse) and keep it low during the high period of the clock pulse (Figure 7). To generate a not acknowledge, the receiver allows SDA to be pulled

high before the rising edge of the acknowledge-related clock pulse and leaves it high during the high period of the clock pulse.

Monitoring the acknowledge bits allows for detection of unsuccessful data transfers. An unsuccessful data transfer happens if a receiving device is busy or if a system fault has occurred. In the event of an unsuccessful data transfer, the master should reattempt communication at a later time.

Slave Address

A master initiates communication with a slave device by issuing a START condition followed by a slave address (Figure 8). The slave address consists of 7 address bits and a read/write bit (R/W). When idle, the device continuously waits for a START condition followed by its slave address. When the device recognizes its slave address, it acquires the data byte and executes the command. The first 3 bits (MSBs) of the slave address have been factory programmed and are always 010. Connect A3–A0 to V_{DD} or GND to program the remaining 4 bits of the slave address. The least significant bit (LSB) of the address byte (R/W) determines whether the master is writing to or reading from the MAX5115/MAX5116. (R/W = 0 selects a write condition. R/W = 1 selects a read condition.) After receiving the address, the MAX5115/MAX5116 (slave) issues an acknowledge by pulling SDA low for one clock cycle.

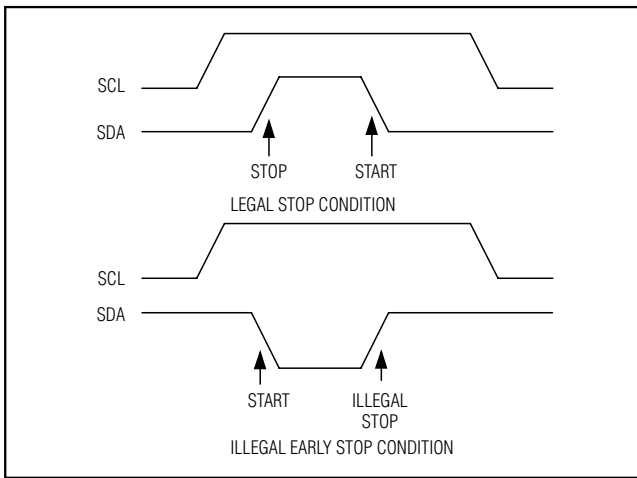

Figure 6. Early STOP Conditions

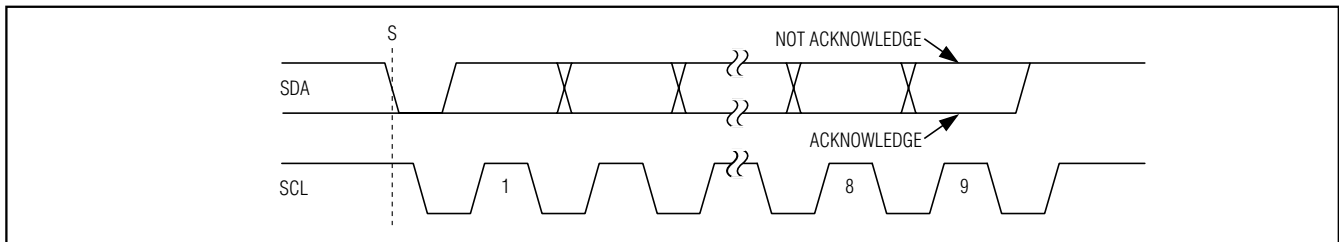

Figure 7. Acknowledge and Not-Acknowledge Bits

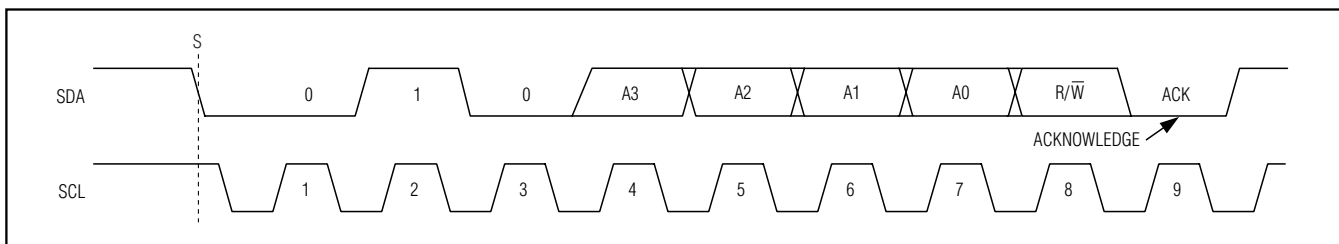

Figure 8. Slave Address Byte

Nonvolatile, Quad, 8-Bit DACs with 2-Wire Serial Interface

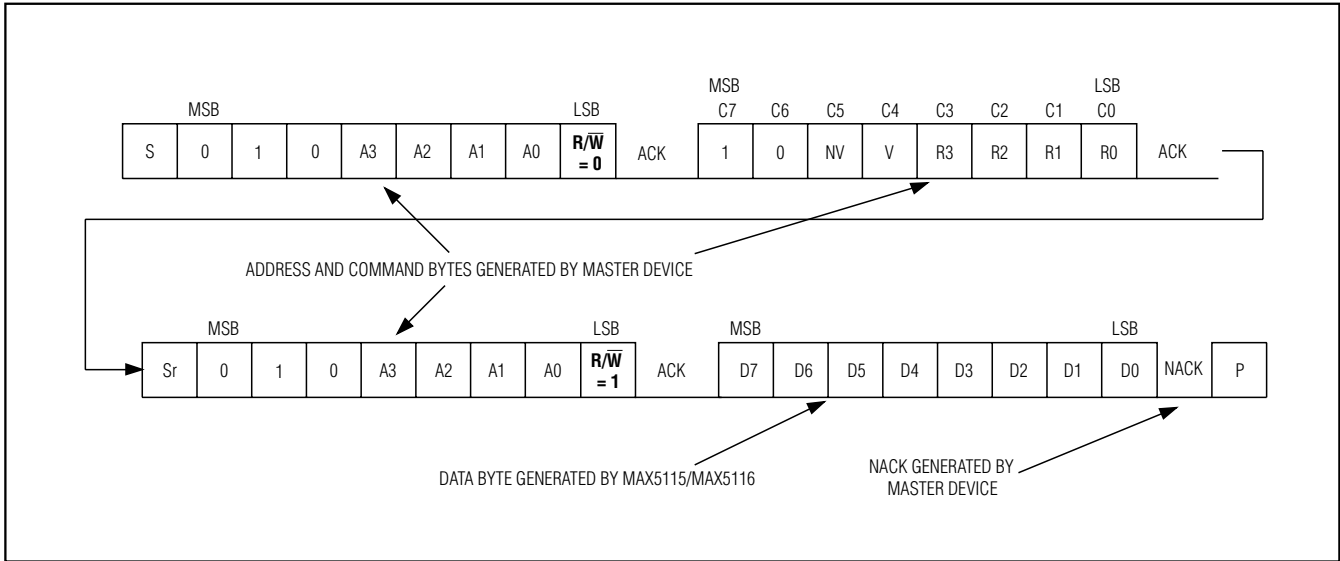

Figure 9. Example Read Word Data Sequence

Write Cycle

The write command requires 27 clock cycles. In write mode ($R/\overline{W} = 0$), the command byte that follows the address byte controls the MAX5115/MAX5116 (Table 1). For a write function, set bits C7 and C6 to zero. Set bits C5 and C4 to select the volatile or nonvolatile register (Table 2). Set bits C3–C0 to select the respective DAC register (Table 3). The registers update on the rising edge of the 26th SCL pulse. Prematurely aborting the write cycle does not update the DAC. See Table 4 for a summary of the write commands.

Read Cycle

A read command requires 36 clock cycles. In read mode, the MAX5115/MAX5116 send the contents of the volatile and nonvolatile registers to the bus. Reading a register requires a REPEATED START (Sr) condition. To

read a register first, write a read command ($R/\overline{W} = 0$, Figure 9). Set the most significant 2 bits of the command byte to 10 (C7 = 1 and C6 = 0). Set bits C5 and C4 to read from either the volatile or nonvolatile register (Table 5). Set bits C3–C0 to select the desired DAC register (Table 6). After the command byte, send a (Sr) condition followed by the address of the device ($R/\overline{W} = 1$). The MAX5115/MAX5116 then acknowledge and send the data on the bus.

Mute/Power-Down Mode

The MAX5115/MAX5116 feature software-controlled mute and power-down modes for each DAC. The power-down mode places the DAC output in a high-impedance state and reduces quiescent-current consumption (25µA (max) with all DACs powered-down).

Table 1. Write Operation

	START	ADDRESS BYTE								R/ \overline{W}	COMMAND BYTE								DATA BYTE								STOP
		Sr	0	1	0	A3	A2	A1	A0		C7	C6	C5	C4	C3	C2	C1	C0	D7	D6	D5	D4	D3	D2	D1	D0	
Master SDA	S	0	1	0	A3	A2	A1	A0	0	C7	C6	NV	V	R3	R2	R1	R0	D7–D0								P	
Slave SDA									ACK									ACK									ACK

Nonvolatile, Quad, 8-Bit DACs with 2-Wire Serial Interface

Table 2. Volatile and Nonvolatile Write Selection

NONVOLATILE (NV)	VOLATILE (V)	FUNCTION
0	0	Transfer data from NVREG_ to VREG_
0	1	Write to VREG_
1	0	Write to NVREG_
1	1	Write to NVREG and VREG_

Table 3. DAC Write Selection

R3	R2	R1	R0	FUNCTION
0	0	0	0	DAC0
0	0	0	1	DAC1
0	0	1	0	DAC2
0	0	1	1	DAC3
1	1	1	1	All DACs*

*This option is only valid for a write to all volatile registers.

Table 4. Write-Command Summary

COMMAND	START	ADDRESS BYTE		ACK	COMMAND BYTE								ACK	DATA BYTE								ACK	STOP
			R/W		C7	C6	C5	C4	C3	C2	C1	C0		MSB				LSB					
					D7	D6	D5	D4	D3	D2	D1	D0											
Write VREG_	S		0		0	0	0	1	R3	R2	R1	R0	D7-D0									P	
Write All VREG_*	S		0		0	0	0	1	1	1	1	1	D7-D0									P	
Write NVREG_	S		0		0	0	1	0	R3	R2	R1	R0	D7-D0									P	
Write VREG_ and NVREG_	S		0		0	0	1	1	R3	R2	R1	R0	D7-D0									P	
Transfer NVREG_ to VREG_	S		0		0	0	0	0	R3	R2	R1	R0	—									P	

*This option is only valid for a write to all volatile registers.

Mute drives the selected DAC output to the corresponding REFL_ voltage. The volatile DAC registers retain data and the output returns to its previous state when mute is disabled. The MAX5116 also features an asynchronous MUTE input that mutes all DACs simultaneously.

The volatile and nonvolatile registers remain active while the MAX5115/MAX5116 are in mute and power-down modes. Writing to or reading from the volatile or nonvolatile registers does not remove the MAX5115/MAX5116 from mute or power-down mode. Writing or transferring data to the volatile registers while the

device is muted or powered down updates the DAC outputs to the new state upon exiting mute or power-down mode.

Mute/Power-Down Register and Operation

Separate nonvolatile and volatile control registers store and update the state of the mute/power-down mode for each DAC. Tables 7 and 8 show how to access and control each register. Register access is gained by setting control bits C3-C0 to 0100. Bits C5 and C4 indicate whether the nonvolatile or volatile control register is accessed. The volatile register maintains data while

Nonvolatile, Quad, 8-Bit DACs with 2-Wire Serial Interface

Table 5. Volatile and Nonvolatile Read Selection

NONVOLATILE (NV)	VOLATILE (V)	FUNCTION
0	1	Read from VREG_
1	0	Read from NVREG_

Table 6. DAC Read Selection

R3	R2	R1	R0	FUNCTION
0	0	0	0	DAC0
0	0	0	1	DAC1
0	0	1	0	DAC2
0	0	1	1	DAC3

Table 7. Mute/Power-Down Operation

COMMAND	START	ADDRESS BYTE		ACK	COMMAND BYTE								ACK	DATA BYTE								ACK	STOP
		R/W			C	C	C	C	C	C	C	C		MSB				LSB					
					7	6	5	4	3	2	1	0		D	D	D	D	D	D	D	D		
Write VCTL	S		0		0	0	0	1	0	1	0	0	Control register*									P	
Write NVCTL	S		0		0	0	1	0	0	1	0	0	Control register*									P	
Write VCTL and NVCTL	S		0		0	0	1	1	0	1	0	0	Control register*									P	
Transfer NVCTL to VCTL	S		0		0	0	0	0	0	1	0	0	Control register*									P	

*See Mute/Power-Down Control Register (Table 8).

Table 8. Mute/Power-Down Control Register

	BIT IN REGISTER							
	D7 (MSB)	D6	D5	D4	D3	D2	D1	D0 (LSB)
CONTROLLING FUNCTION	Mute DAC3	Mute DAC2	Mute DAC1	Mute DAC0	Power-down DAC3	Power-down DAC2	Power-down DAC1	Power-down DAC0

the device remains powered. The nonvolatile register maintains data even after power is removed. The MAX5115/MAX5116 start up (power first applied) by transferring the mute/power-down from the nonvolatile to the volatile control register. The nonvolatile control register is set to 00 hex at the factory.

Power-On Reset

Power-on reset (POR) circuitry controls the initialization of the MAX5115/MAX5116. A power-on reset loads the volatile registers with the data stored in the nonvolatile registers.

This initialization period takes 500µs (typ). During this time, the DAC outputs are held in mute mode. At the completion of the initialization period, the DAC outputs update in accordance with the configuration register.

DAC Data

The 8-bit DAC data is decoded as offset binary, MSB first, with 1 LSB = $(V_{REFH} - V_{REFL}) / 256$, and converted into the corresponding analog voltage as shown in Table 9.

Nonvolatile, Quad, 8-Bit DACs with 2-Wire Serial Interface

MAX5115/MAX5116

Applications Information

DAC Linearity and Offset Voltage

The output buffer can have a negative input offset voltage that would normally drive the output negative, but with no negative supply, the output remains at GND (Figure 10). Determine linearity using the end-point method, measuring between code 10 (0A hex) and code 240 (F0 hex) after calibrating the offset and gain error (Figure 10).

External Voltage Reference

The MAX5115 features two reference inputs for each DAC (REFH_ and REFL_). The MAX5116 uses a single reference for all four DACs (REFH and REFL). REFH_ sets the full-scale voltage, while REFL_ sets the zero code output. The MAX5115 has a 460kΩ typical input impedance that is independent of the code. The MAX5116 has a 115kΩ typical input impedance that is independent of the code.

Power Sequencing

The voltage applied to REFH_ and REFL_ should not exceed V_{DD} at any time. If proper power sequencing is not possible, connect an external Schottky diode between REFH_, REFL_, and V_{DD} to ensure compliance with the absolute maximum ratings. Do not apply signals to the digital inputs before the device is fully powered.

Power-Supply Bypassing and Ground Management

Digital or AC transient signals on GND can create noise at the analog output. Return GND to the highest-quality ground available. Bypass V_{DD} with a 0.1μF capacitor, located as close to the device as possible. Bypass REFH_ and REFL_ to GND with 0.1μF capacitors. Careful PC board ground layout minimizes crosstalk between the DAC outputs and digital inputs.

Table 9. Unipolar Code Output Voltage

DAC CODE	OUTPUT VOLTAGE (V)
1111 1111	$\frac{255 \times (V_{REFH_} - V_{REFL_})}{256} + V_{REFL_}$
1000 0000	$\frac{128 \times (V_{REFH_} - V_{REFL_})}{256} + V_{REFL_}$
0000 0001	$\frac{(V_{REFH_} - V_{REFL_})}{256} + V_{REFL_}$
0000 0000	V _{REFL_}

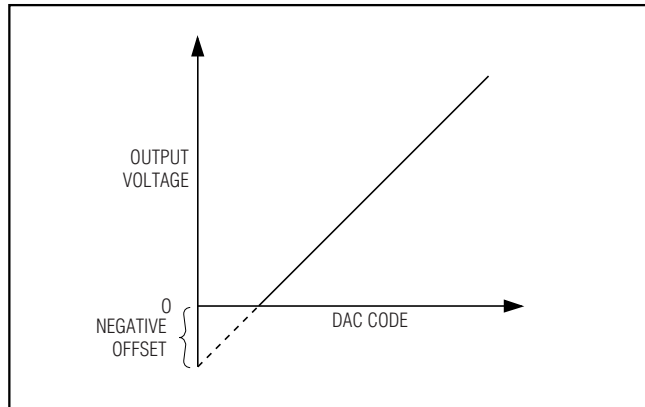
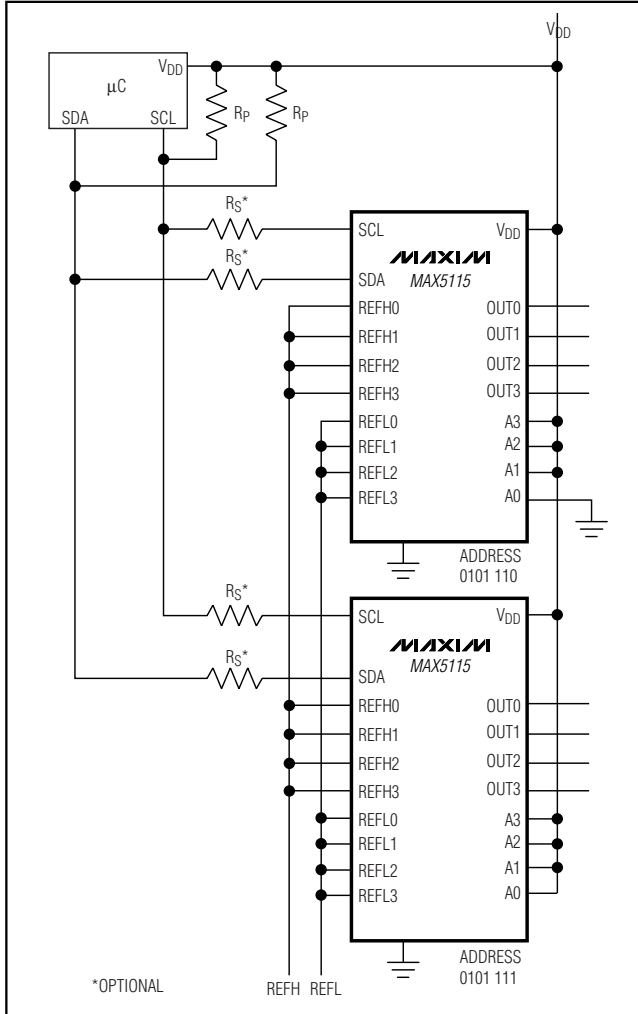

Figure 10. Effect of Negative Offset (Single Supply)

Nonvolatile, Quad, 8-Bit DACs with 2-Wire Serial Interface

Typical Operating Circuit



Pin Configurations

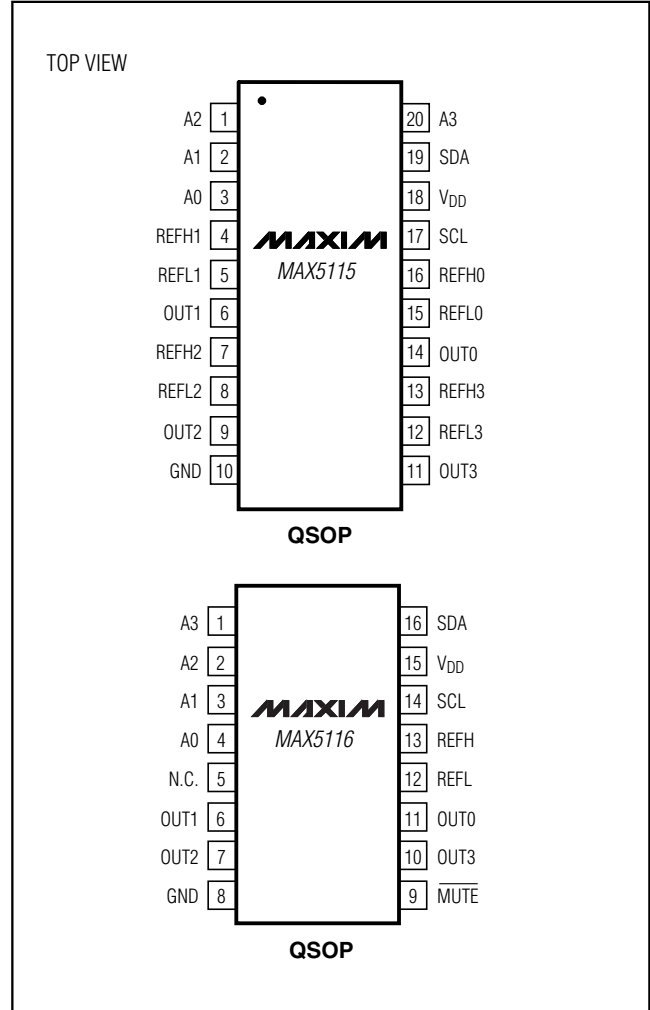

Chip Information

TRANSISTOR COUNT: 40,209
 PROCESS: BiCMOS

Nonvolatile, Quad, 8-Bit DACs with 2-Wire Serial Interface

Package Information

(The package drawing(s) in this data sheet may not reflect the most current specifications. For the latest package outline information, go to www.maxim-ic.com/packages.)

MAX5115/MAX5116

QSOP-EPS

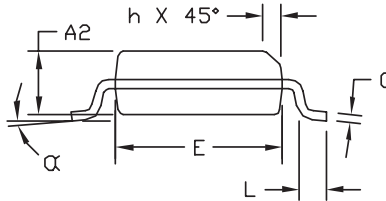
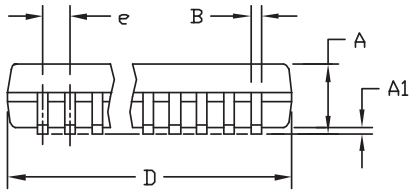
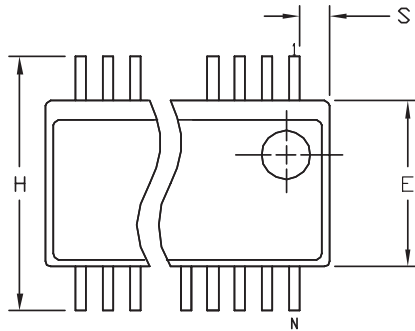

DIM	INCHES		MILLIMETERS	
	MIN	MAX	MIN	MAX
A	.053	.069	1.35	1.75
A1	.004	.010	.102	.254
A2	.049	.065	1.245	1.651
B	.008	.012	0.20	0.30
C	.0075	.0098	0.191	0.249
D	SEE VARIATIONS			
E	.150	.157	3.81	3.99
e	.025 BSC		0.635 BSC	
H	.230	.244	5.84	6.20
h	.010	.016	0.25	0.41
L	.016	.035	0.41	0.89
N	SEE VARIATIONS			
α	0°	8°	0°	8°

VARIATIONS:

DIM	INCHES		MILLIMETERS		N
	MIN.	MAX.	MIN.	MAX.	
D	.189	.196	4.80	4.98	16 AB
S	.0020	.0070	0.05	0.18	
D	.337	.344	8.56	8.74	20 AD
S	.0500	.0550	1.270	1.397	
D	.337	.344	8.56	8.74	24 AE
S	.0250	.0300	0.635	0.762	
D	.386	.393	9.80	9.98	28 AF
S	.0250	.0300	0.635	0.762	

NOTES:

- 1). D & E DO NOT INCLUDE MOLD FLASH OR PROTRUSIONS.
- 2). MOLD FLASH OR PROTRUSIONS NOT TO EXCEED .006" PER SIDE.
- 3). CONTROLLING DIMENSIONS: INCHES.
- 4). MEETS JEDEC MO137.

DALLAS SEMICONDUCTOR **MAXIM**
 PROPRIETARY INFORMATION
 TITLE
 PACKAGE OUTLINE, QSOP .150", .025" LEAD PITCH
 APPROVAL _____ DOCUMENT CONTROL NO. 21-0055 REV. F 1/1

Maxim cannot assume responsibility for use of any circuitry other than circuitry entirely embodied in a Maxim product. No circuit patent licenses are implied. Maxim reserves the right to change the circuitry and specifications without notice at any time.

Maxim Integrated Products, 120 San Gabriel Drive, Sunnyvale, CA 94086 408-737-7600 _____ 19

Looking for pricing, stock, or lifecycle information?

Click below to explore more details on WIN SOURCE:

- ⊖ [View MAX5116EEE+ on WIN SOURCE](#)
- ⊖ [Maxim Integrated Information](#)

Optimize Your Supply Chain with WIN SOURCE Solutions

- ✓ Global Sourcing Solution
- ✓ Obsolete Management
- ✓ Cost Control Management
- ✓ Shortage Management
- ✓ Alternative Solution
- ✓ Excess Inventory Management