

# 2SC5019

## Silicon NPN epitaxial planar type

For UHF band low-noise amplification

### ■ Features

- Low noise figure NF
- High maximum unilateral power gain  $G_{UM}$
- High transition frequency  $f_T$
- Mini Power type package, allowing downsizing of the equipment and automatic insertion through the tape packing and the magazine packing

### ■ Absolute Maximum Ratings $T_a = 25^\circ\text{C}$

| Parameter                             | Symbol    | Rating      | Unit             |
|---------------------------------------|-----------|-------------|------------------|
| Collector-base voltage (Emitter open) | $V_{CBO}$ | 15          | V                |
| Collector-emitter voltage (Base open) | $V_{CEO}$ | 10          | V                |
| Emitter-base voltage (Collector open) | $V_{EBO}$ | 2           | V                |
| Collector current                     | $I_C$     | 80          | mA               |
| Collector power dissipation *         | $P_C$     | 1           | W                |
| Junction temperature                  | $T_j$     | 150         | $^\circ\text{C}$ |
| Storage temperature                   | $T_{stg}$ | -55 to +150 | $^\circ\text{C}$ |

Note) \*: Copper plate at the collector is more than  $1\text{ cm}^2$  in area, 1.7 mm in thickness  
Absolute maximum rating without heat sink for  $P_C$  is 0.5 W

### ■ Electrical Characteristics $T_a = 25^\circ\text{C} \pm 3^\circ\text{C}$

| Parameter  | Symbol        | Conditions   | Min | Typ  | Max | Unit          |
|--|---------------|--|-----|------|-----|---------------|
| Collector-base voltage (Emitter open)                            | $V_{CBO}$     | $I_C = 10\ \mu\text{A}$ , $I_E = 0$                                    | 15  |      |     | V             |
| Collector-emitter voltage (Base open)                            | $V_{CEO}$     | $I_C = 100\ \mu\text{A}$ , $I_B = 0$                                   | 10  |      |     | V             |
| Collector-base cutoff current (Emitter open)                     | $I_{CBO}$     | $V_{CB} = 10\ \text{V}$ , $I_E = 0$                                    |     |      | 1   | $\mu\text{A}$ |
| Emitter-base cutoff current (Collector open)                     | $I_{EBO}$     | $V_{EB} = 2\ \text{V}$ , $I_C = 0$                                     |     |      | 1   | $\mu\text{A}$ |
| Forward current transfer ratio                                   | $h_{FE}$      | $V_{CE} = 8\ \text{V}$ , $I_C = 20\ \text{mA}$                         | 80  |      | 250 | —             |
| Transition frequency   | $f_T$         | $V_{CE} = 8\ \text{V}$ , $I_C = 20\ \text{mA}$ , $f = 0.8\ \text{GHz}$ | 5   | 6    |     | GHz           |
| Collector output capacitance (Common base, input open circuited) | $C_{ob}$      | $V_{CB} = 10\ \text{V}$ , $I_E = 0$ , $f = 1\ \text{MHz}$              |     | 0.9  | 1.2 | pF            |
| Forward transfer gain  | $ S_{21e} ^2$ | $V_{CE} = 8\ \text{V}$ , $I_C = 20\ \text{mA}$ , $f = 0.8\ \text{GHz}$ | 7.5 | 10.0 |     | dB            |
| Maximum unilateral power gain                                    | $G_{UM}$      | $V_{CE} = 8\ \text{V}$ , $I_C = 20\ \text{mA}$ , $f = 0.8\ \text{GHz}$ |     | 11.5 |     | dB            |
| Noise figure   | NF            | $V_{CE} = 8\ \text{V}$ , $I_C = 7\ \text{mA}$ , $f = 0.8\ \text{GHz}$  |     | 1.7  |     | dB            |

Note) Measuring methods are based on JAPANESE INDUSTRIAL STANDARD JIS C 7030 measuring methods for transistors.

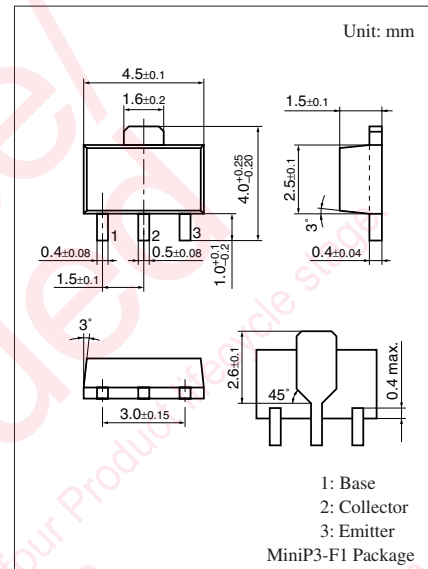

Marking Symbol: 1W

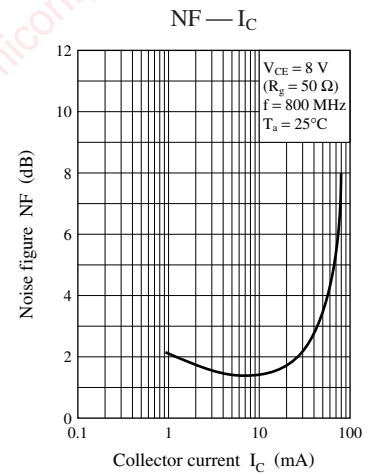
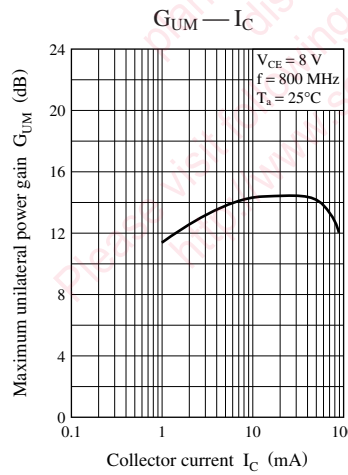
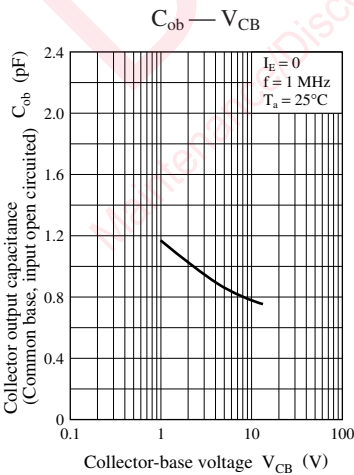
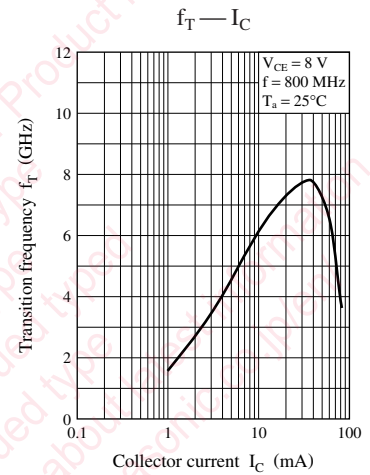
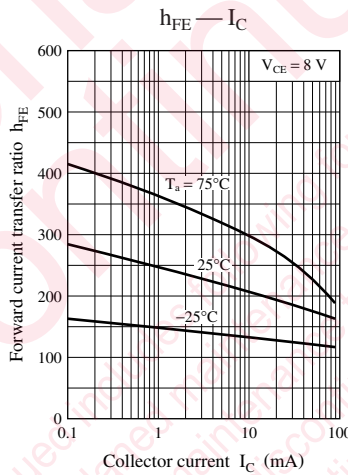
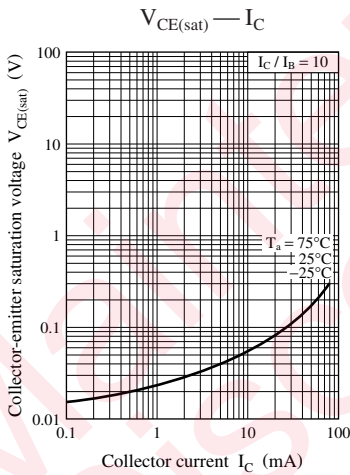
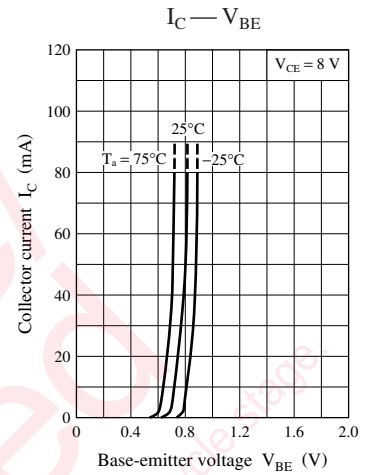
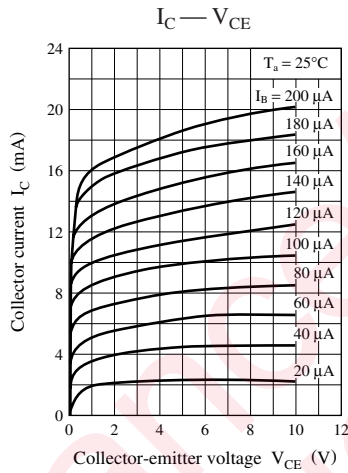
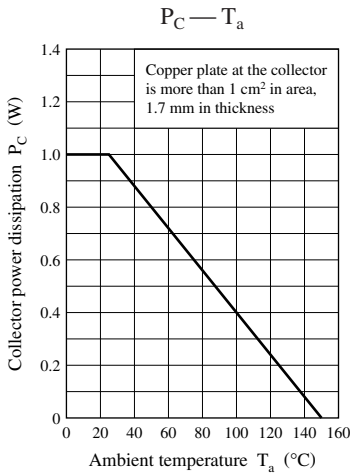

## utions in using the technical information and scribed in this book

s book is to be exported or provided to non-residents, the laws and  
rd to security export control, must be observed.

ly to show the main characteristics and application circuit examples  
l property right or other right owned by our company or any other  
any as to the infringement upon any such right owned by any other  
rmation described in this book.

standard applications or general electronic equipment (such as office  
and household appliances).

ng applications:

biles, traffic control equipment, combustion equipment, life support  
reliability are required, or if the failure or malfunction of the prod-

k are subject to change without notice for modification and/or im-  
use of the products, therefore, ask for the most up-to-date Product  
atisfy your requirements.

bsolute maximum rating and the guaranteed operating conditions  
(.). Especially, please be careful not to exceed the range of absolute  
r-off and mode-switching. Otherwise, we will not be liable for any

take into the consideration of incidence of break down and failure  
n the systems such as redundant design, arresting the spread of fire  
al injury, fire, social damages, for example, by using the products.

own and characteristics change due to external factors (ESD, EOS,  
mounting or at customer's process. When using products for which  
shelf life and the elapsed time since first opening the packages.

ly or partially, without the prior written permission of Matsushita

## Looking for pricing, stock, or lifecycle information?

Click below to explore more details on WIN SOURCE:

 [View 2SC5019-\(TX\) on WIN SOURCE](#)

 [Panasonic Information](#)

## Optimize Your Supply Chain with WIN SOURCE Solutions

-  Global Sourcing Solution
-  Obsolete Management
-  Cost Control Management
-  Shortage Management
-  Alternative Solution
-  Excess Inventory Management