



**THE DATASHEET OF  
MAX6330TUR-T**



# MAX6330/MAX6331

# Precision Shunt Regulators with Reset in SOT23-3

## General Description

The MAX6330/MAX6331 combine a precision shunt regulator with a power-on reset function in a single SOT23-3 package. They offer a low-cost method of operating small microprocessor ( $\mu\text{P}$ )-based systems from high-voltage sources, while simultaneously protecting  $\mu\text{P}$ s from power-up, power-down, and brownout conditions.

Both active-low (MAX6330) and active-high (MAX6331) push/pull output versions are available. The output voltage has  $\pm 1.5\%$  tolerance. The MAX6330/MAX6331 operate over a wide shunt current range from  $100\mu\text{A}$  to  $50\text{mA}$ , and offer very good transient immunity.

A 3-pin SOT23 package allows for a significant reduction in board space and improves reliability compared to multiple-IC/discrete solutions. These devices have a minimum order increment of 2,500 pieces.

## Applications

- Controllers
- Household Appliances
- Intelligent Instruments
- Critical  $\mu\text{P}$  and  $\mu\text{C}$  Power Monitoring
- Portable/Size-Sensitive Equipment

## Typical Operating Circuit

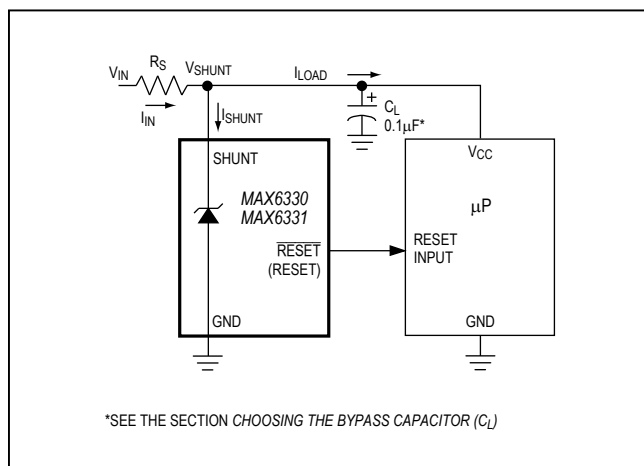

## Features

- $100\mu\text{A}$  to  $50\text{mA}$  Shunt Current Range
- Low Cost
- 3-Pin SOT23 Package
- $\pm 1.5\%$  Tolerance on Output Voltage
- Three Shunt Voltages Available:  $5\text{V}$ ,  $3.3\text{V}$ ,  $3.0\text{V}$
- Precision Power-On Reset Threshold:  $1.5\%$  Tolerance Available with Either RESET (MAX6331) or  $\overline{\text{RESET}}$  (MAX6330) Outputs
- $140\text{ms}$  Reset Timeout Period—No External Components Required

## Ordering Information

PART*	TEMP RANGE	PIN-PACKAGE
MAX6330_UR-T	$-40^\circ\text{C}$ to $+85^\circ\text{C}$	3 SOT23-3
MAX6331_UR-T	$-40^\circ\text{C}$ to $+85^\circ\text{C}$	3 SOT23-3

\*Insert the desired suffix letter (from the table below) into the blank to complete the part number. These devices have a minimum order increment of 2,500 pieces.

Devices are available in both leaded and lead-free packaging. Specify lead-free by replacing “-T” with “+T” when ordering.

SUFFIX	RESET THRESHOLD (V)	SHUNT REGULATOR VOLTAGE (V)	SOT TOP MARK	
			MAX6330	MAX6331
L	4.63	5.0	EKAA	ELAA
T	3.06	3.3	EMAA	ENAA
S	2.78	3.0	EDAA	EPAA

## Pin Configuration

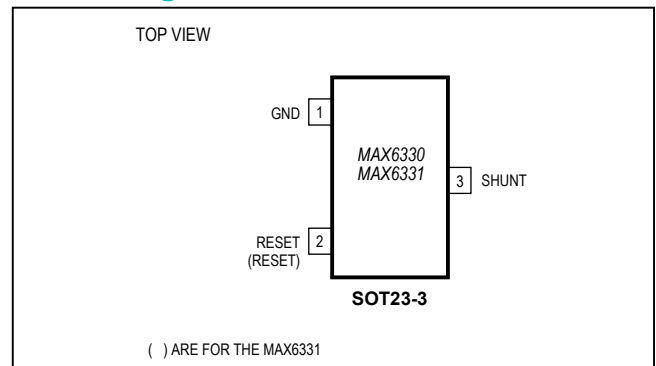

**Absolute Maximum Ratings**

Terminal Voltage (with respect to GND),  
All Pins Except SHUNT ..... -0.3V to (V<sub>SHUNT</sub> + 0.3V)  
Input Current (I<sub>SHUNT</sub>) ..... 60mA  
Output Current (RESET/RESET) ..... 20mA  
Short-Circuit Duration ..... Continuous

Continuous Power Dissipation  
SOT23-3 (derate 4mW/°C above +70°C) ..... 320mW  
Operating Temperature Range ..... -40°C to +85°C  
Storage Temperature Range ..... -65°C to +160°C  
Lead Temperature (soldering, 10sec) ..... +300°C

*Stresses beyond those listed under "Absolute Maximum Ratings" may cause permanent damage to the device. These are stress ratings only, and functional operation of the device at these or any other conditions beyond those indicated in the operational sections of the specifications is not implied. Exposure to absolute maximum rating conditions for extended periods may affect device reliability.*

**Electrical Characteristics**

(I<sub>SHUNT</sub> = 1mA, C<sub>L</sub> = 0.1µF, T<sub>A</sub> = -40°C to +85°C, unless otherwise noted. Typical values are at T<sub>A</sub> = +25°C.)

PARAMETER	SYMBOL	CONDITIONS		MIN	TYP	MAX	UNITS	
V <sub>SHUNT</sub> Regulation Voltage (Note 1)	V <sub>SHUNT</sub>	I <sub>SHUNT</sub> = 0.1 mA to 50mA	MAX633_L	T <sub>A</sub> = +25°C	4.93	5.0	5.07	V
				T <sub>A</sub> = -40°C to +85°C	4.85		5.15	
			MAX633_T	T <sub>A</sub> = +25°C	3.25	3.3	3.35	
				T <sub>A</sub> = -40°C to +85°C	3.20		3.40	
			MAX633_S	T <sub>A</sub> = +25°C	2.96	3.0	3.04	
				T <sub>A</sub> = -40°C to +85°C	2.91		3.09	
Minimum V <sub>SHUNT</sub> for which RESET is Valid (MAX6330)			T <sub>A</sub> = 0°C to +70°C	1.0			V	
			T <sub>A</sub> = -40°C to +85°C	1.2				
V <sub>SHUNT</sub> Tempco					40		ppm/°C	
Minimum Shunt Current (Note 2)	I <sub>SHUNT(min)</sub>			100	60		µA	
Maximum Shunt Current (Note 3)	I <sub>SHUNT(max)</sub>					50	mA	
Reset Threshold Voltage	V <sub>TH</sub>		MAX633_L	T <sub>A</sub> = +25°C	4.56	4.63	4.69	V
				T <sub>A</sub> = -40°C to +85°C	4.50		4.75	
			MAX633_T	T <sub>A</sub> = +25°C	3.01	3.06	3.11	
				T <sub>A</sub> = -40°C to +85°C	2.97		3.15	
			MAX633_S	T <sub>A</sub> = +25°C	2.74	2.78	2.82	
				T <sub>A</sub> = -40°C to +85°C	2.70		2.86	
Reset Threshold Tempco					40		ppm/°C	
V <sub>SHUNT</sub> to Reset Delay			100mV overdrive, C <sub>L</sub> = 15pF		20		µs	
Reset Pulse Width				100	140	200	ms	

Electrical Characteristics (continued)

(I<sub>SHUNT</sub> = 1mA, C<sub>L</sub> = 0.1μF, T<sub>A</sub> = -40°C to +85°C, unless otherwise noted. Typical values are at T<sub>A</sub> = +25°C.)

RESET/ $\overline{\text{RESET}}$ Output Voltage Low (Note 4)	VOL	I <sub>SINK</sub> = 3.2mA	MAX6330L, V <sub>TH(min)</sub>	0.4	V
			MAX6331L, V <sub>TH(max)</sub>		
		I <sub>SINK</sub> = 1.2mA	MAX6330T/S, V <sub>TH(min)</sub>	0.3	
			MAX6331T/S, V <sub>TH(max)</sub>		
		MAX6330, V <sub>SHUNT</sub> = 1V, I <sub>SINK</sub> = 50μA, T <sub>A</sub> = 0°C to +70°C			
MAX6330, V <sub>SHUNT</sub> = 1.2V, I <sub>SINK</sub> = 50μA, T <sub>A</sub> = -40°C to +85°C			0.3		
RESET/ $\overline{\text{RESET}}$ Output Voltage High (Note 4)	VOH	I <sub>SOURCE</sub> = 800μA	MAX6331L, V <sub>TH(min)</sub>	0.8 x V <sub>SHUNT</sub>	V
			MAX6330L, V <sub>TH(max)</sub>		
		I <sub>SOURCE</sub> = 500μA	MAX6331T/S, V <sub>TH(min)</sub>	0.8 x V <sub>SHUNT</sub>	
			MAX6330T/S, V <sub>TH(max)</sub>		
		MAX6331, 1.8V < V <sub>SHUNT</sub> < V <sub>TH(min)</sub> , I <sub>SOURCE</sub> = 150μA			

**Note 1:** It is recommended that the regulation voltage be measured using a 4-wire force-sense technique when operating at high shunt currents. For operating at elevated temperatures, the device must be derated based on a +150°C maximum allowed junction temperature and a maximum thermal resistance of 0.25°C/mW junction to ambient when soldered on a printed circuit board. The T<sub>A</sub> = +25°C specification over load is measured using a pulse test at 50mA with less than 5ms on time.

**Note 2:** Minimum shunt current required for regulated V<sub>SHUNT</sub>.

**Note 3:** Maximum shunt current required for regulated V<sub>SHUNT</sub>.

**Note 4:** In a typical application where SHUNT serves as the system voltage regulator, note that both I<sub>SOURCE</sub> for V<sub>OH</sub> and I<sub>SINK</sub> for V<sub>OL</sub> come from V<sub>SHUNT</sub> (see the *Typical Operating Circuit*).

Typical Operating Characteristics

(Typical Operating Circuit,  $C_L = 0.1\mu\text{F}$ ,  $I_{\text{LOAD}} = 0\text{mA}$ ,  $T_A = +25^\circ\text{C}$ , unless otherwise noted.)

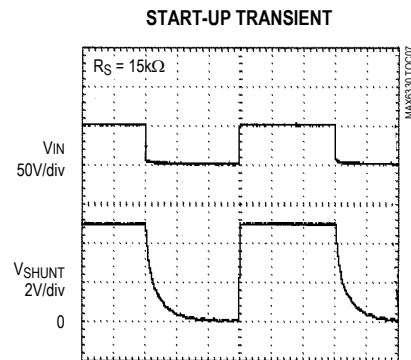
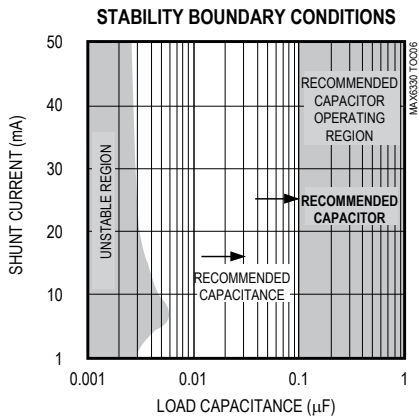
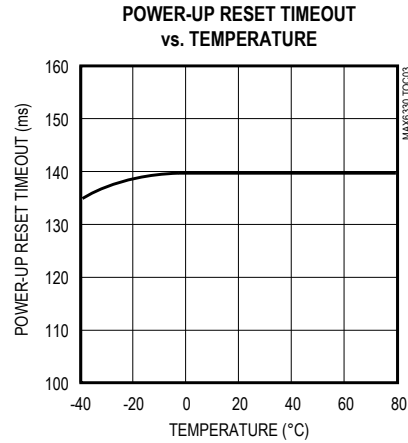
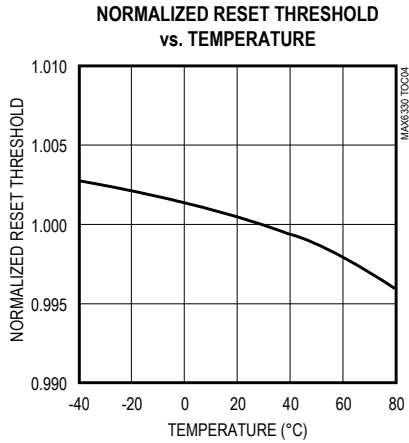
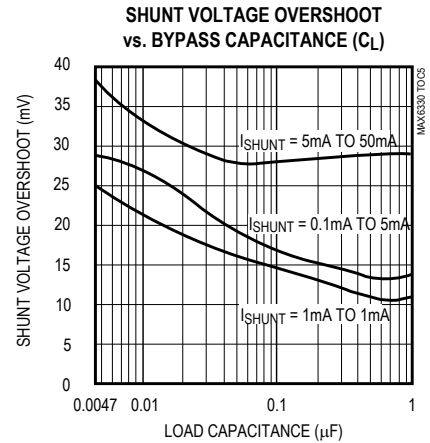
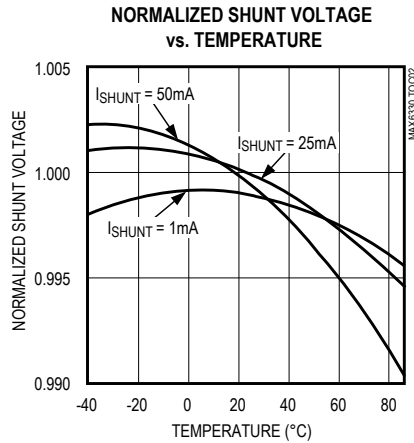
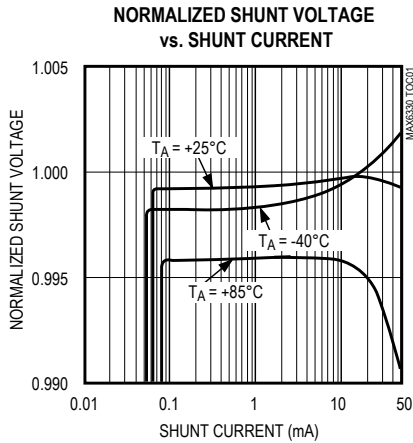

Pin Description

PIN		NAME	FUNCTION
MAX6330	MAX6331		
1	1	GND	Ground
2	—	$\overline{\text{RESET}}$	Inverting Reset Output. $\overline{\text{RESET}}$ remains low while $V_{\text{SHUNT}}$ is below the reset threshold and for 140ms after $V_{\text{SHUNT}}$ rises above the threshold.
—	2	RESET	Noninverting Reset Output. RESET remains high while $V_{\text{SHUNT}}$ is below the reset threshold and for 140ms after $V_{\text{SHUNT}}$ rises above the threshold.
3	3	SHUNT	Regulated Shunt Voltage (+5V, +3.3V, or +3.0V)

Detailed Description

Reset Output

A microprocessor's ( $\mu\text{P}$ 's) reset input starts the  $\mu\text{P}$  in a known state. The MAX6330/MAX6331  $\mu\text{P}$  supervisory circuits assert reset to prevent code-execution errors during power-up, power-down, or brownout conditions.

$\overline{\text{RESET}}$  is guaranteed to be a logic low for  $V_{\text{SHUNT}} > 1\text{V}$ . Once  $V_{\text{SHUNT}}$  exceeds the reset threshold, an internal timer keeps  $\overline{\text{RESET}}$  low for the reset timeout period; after this interval,  $\overline{\text{RESET}}$  goes high.

If a brownout condition occurs ( $V_{\text{SHUNT}}$  dips below the reset threshold),  $\overline{\text{RESET}}$  goes low. When  $V_{\text{SHUNT}}$  falls below the reset threshold, the internal timer resets to zero and  $\overline{\text{RESET}}$  goes low. The internal timer starts after  $V_{\text{SHUNT}}$  returns above the reset threshold, and  $\overline{\text{RESET}}$  then remains low for the reset timeout period.

The MAX6331 has an active-high RESET output that is the inverse of the MAX6330's  $\overline{\text{RESET}}$  output.

Shunt Regulator

The shunt regulator consists of a pass device and a controlling circuit, as illustrated in Figure 1. The pass device allows the regulator to sink current while regulating the desired output voltage within a  $\pm 1.5\%$  tolerance. The shunt current range ( $I_{\text{SHUNT}}$ ) is  $100\mu\text{A}$  to  $50\text{mA}$ .

The pass transistor in the MAX6330/MAX6331 maintains a constant output voltage ( $V_{\text{SHUNT}}$ ) by sinking the necessary amount of shunt current. When  $I_{\text{LOAD}}$  (see *Typical Operating Circuit*) is at a maximum, the shunt current is at a minimum, and vice versa:

$$I_{\text{IN}} = I_{\text{SHUNT}} + I_{\text{LOAD}} = (V_{\text{IN}} - V_{\text{SHUNT}}) / R_{\text{S}}$$

Consider the following information when choosing the external resistor  $R_{\text{S}}$ :

- 1) The input voltage range, ( $V_{\text{IN}}$ )
- 2) The regulated voltage, ( $V_{\text{SHUNT}}$ )
- 3) The output current range, ( $I_{\text{LOAD}}$ )

Choose  $R_{\text{S}}$  as follows:

$$(V_{\text{IN}(\text{max})} - V_{\text{SHUNT}(\text{min})}) / (50\text{mA} + I_{\text{LOAD}(\text{min})}) \leq R_{\text{S}} \leq (V_{\text{IN}(\text{min})} - V_{\text{SHUNT}(\text{max})}) / (100\mu\text{A} + I_{\text{LOAD}(\text{max})})$$

Choose the largest nominal resistor value for  $R_{\text{S}}$  that gives the lowest current consumption. Provide a safety margin to incorporate the worst-case tolerance of the

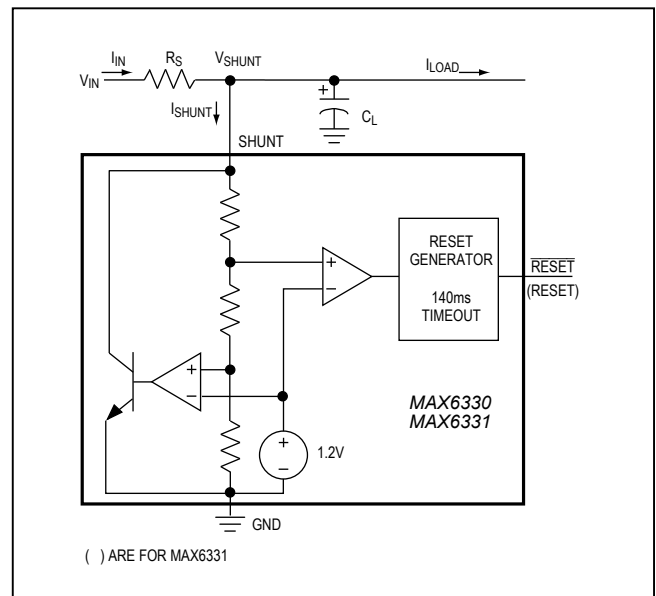

Figure 1. Functional Diagram

resistor used. Ensure that the resistor’s power rating is adequate, using the following general power equation:

$$P_R = I_{IN}(V_{IN(max)} - V_{SHUNT}) = I_{IN}^2 R_S = (V_{IN(max)} - V_{SHUNT})^2 / R_S$$

### Applications Information

#### Negative-Going VSHUNT Transients

In addition to issuing a reset to the μP during power-up, power-down, and brownout conditions, the MAX6330/MAX6331 are relatively immune to short-duration negative-going VSHUNT transients (glitches). Additional bypass filter capacitance mounted close to the SHUNT pin provides additional transient immunity.

#### Choosing the Bypass Capacitor, CL

The bypass capacitor (CL) on the SHUNT pin can significantly affect the device’s load-transient response, so choose it carefully. When a load transient occurs, the current for this load is diverted from the shunt regulator.

The maximum load current that can be diverted from the regulator is:

$$I_{LOAD} \text{ (diverted from regulator)} = I_{SHUNT(max)} - I_{SHUNT(min)} = 50\text{mA} - 100\mu\text{A} = 49.9\text{mA}$$

The shunt regulator has a finite response to this transient. The instantaneous requirements of the load change are met by the charge on CL, resulting in overshoot/undershoot on VSHUNT. The magnitude of this overshoot/undershoot increases with ISHUNT and decreases with CL. When VSHUNT undershoots, the shunt current decreases to where it will only draw quiescent current (IQ), and the shunt element turns off. At this point, VSHUNT will slew toward VIN at the following rate:

$$\Delta V_{SHUNT} / \Delta t = (I_{IN} - I_{LOAD} - 60\mu\text{A}) / C_L$$

As VSHUNT rises, it will turn on the shunt regulator when it can sink 100μA of current. A finite response time for the shunt regulator to start up will result in a brief overshoot of VSHUNT before it settles into its regulation voltage. Therefore, ILOAD should always be 100μA or more below IIN, or VSHUNT will not recover to its regulation point. To prevent this condition, be sure to select the correct series-resistor RS value (see the Shunt Regulator section).

Figures 2, 3, and 4 show load-transient responses for different choices of bypass capacitors on VSHUNT. These photos clearly illustrate the benefits and drawbacks of the capacitor options. A smaller bypass

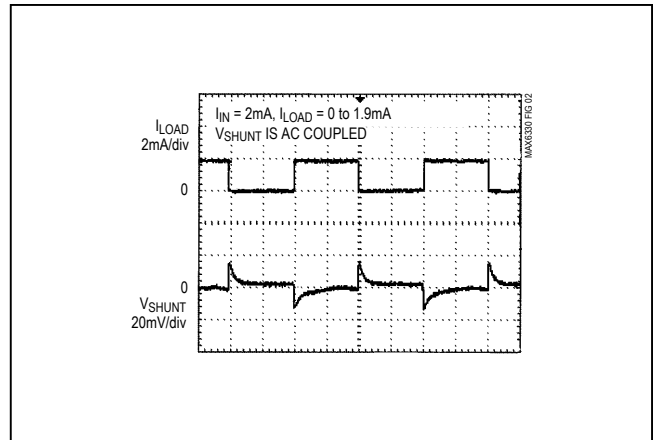

Figure 2. Load-Transient Response with CL = 0.22μF

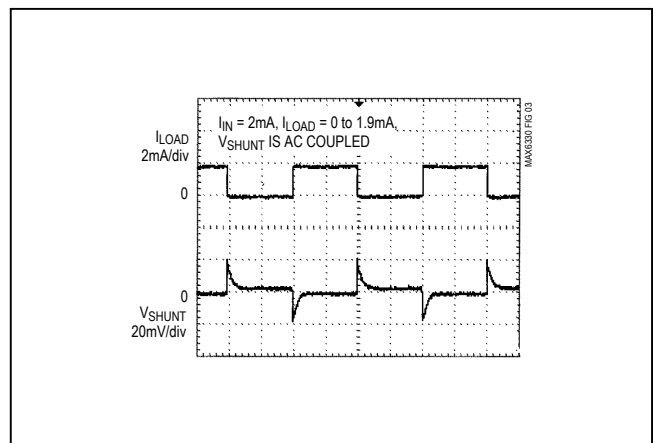

Figure 3. Load-Transient Response with CL = 0.033μF

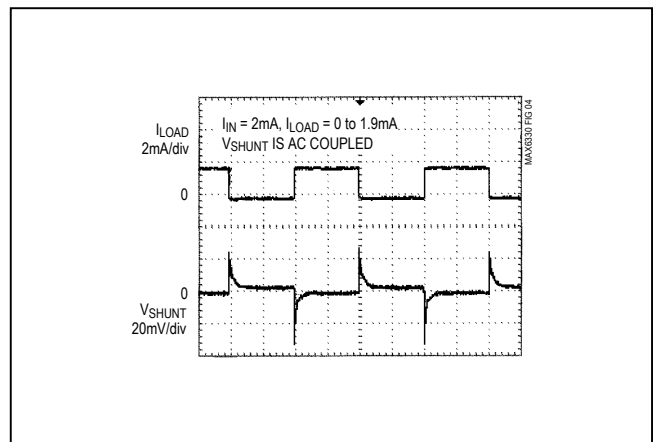

Figure 4. Load-Transient Response with CL = 0.0047μF

capacitor allows a sharper drop in  $V_{SHUNT}$  when the load transient occurs, and will suffer from a steeper overshoot when the device re-enters regulation. On the other hand, the increased compensation on a larger bypass capacitor will lead to a longer recovery time to regulation. The *Typical Operating Characteristics* graph Overshoot vs. Bypass Capacitance ( $C_L$ ) illustrates this trade-off.

If the compensation of the bypass capacitor chosen is insufficient, the output ( $V_{SHUNT}$ ) can oscillate. Before choosing a bypass capacitor for the desired shunt current, observe the stability boundary conditions indicated in the *Typical Operating Characteristics*. The minimum output capacitance is  $0.03\mu F$  to ensure stability over the full load-current range.

**Adding Hysteresis**

In certain circumstances, the MAX6330 can be trapped in a state that forces it to enter into and exit from a reset condition indefinitely. This usually occurs in systems where  $V_{SHUNT}$  is just below the device’s trip threshold and the system draws less quiescent current under reset conditions than when operating out of reset. The difference in supply current when the device is in or out of reset can translate to a significant change in the voltage drop across  $R_S$ , which the MAX6330’s built-in hysteresis may not overcome. A  $100k\Omega$  pull-up resistor will overcome this condition and add hysteresis (Figure 5).

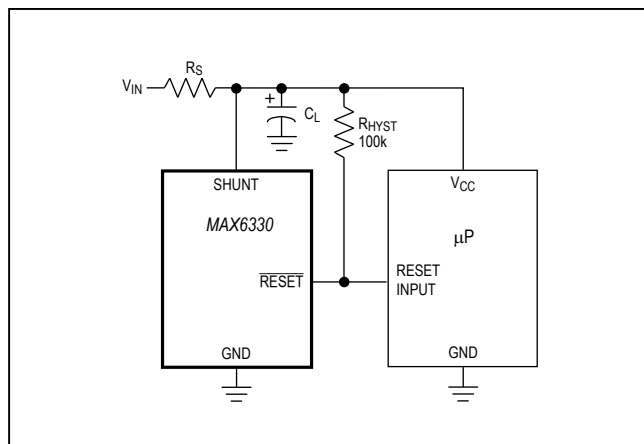

Figure 5. Adding Hysteresis to the MAX6330

Note that adding this pull-up resistor to the MAX6330 will render  $\overline{RESET}$  invalid with  $V_{SHUNT} < 1V$ , since this output loses sinking capability at this point, and the pull-up resistor would invalidate the signal. This does not present a problem in most applications, since most  $\mu P$ s and other circuitry are inoperative when  $V_{SHUNT}$  is below  $1V$ .

**Interfacing to  $\mu P$ s with Bidirectional Reset Pins**

Microprocessors with bidirectional reset pins (such as the Motorola 68HC11 series) can contend with MAX6330’s reset output. If, for example, the MAX6330’s  $\overline{RESET}$  output is asserted high and the  $\mu P$  wants to pull it low, indeterminate logic levels may result. To correct this, connect a  $4.7k\Omega$  resistor between the  $\overline{RESET}$  output and the  $\mu P$  reset I/O (Figure 6). Buffer the  $\overline{RESET}$  output to other system components. Also,  $R_S$  must be sized to compensate for additional current drawn by the  $\mu P$  during the fault condition.

**Shunt Current Effects on  $V_{SHUNT}$  and  $V_{TH}$**

When sinking large shunt currents, power dissipation heats the die to temperatures greater than ambient. This may cause the  $V_{SHUNT}$  and  $V_{TH}$  tolerances to approach  $\pm 3\%$  at high ambient temperatures and high shunt currents. Limit the die temperature to less than  $+150^\circ C$  using  $\Theta_{JA} = 0.25^\circ C/mW$ .

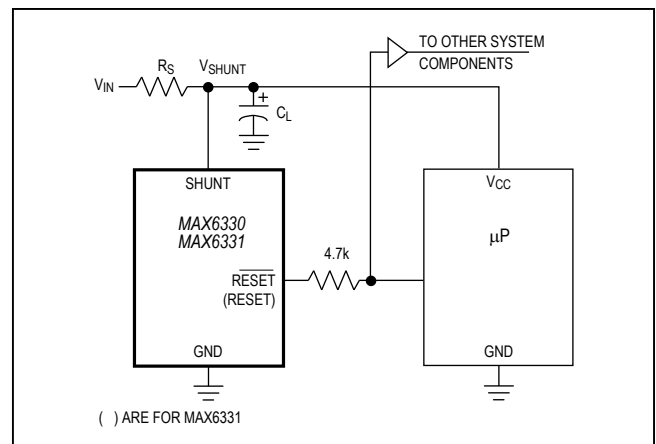

Figure 6. Interfacing to  $\mu P$ s with Bidirectional Reset I/O

### Chip Information

TRANSISTOR COUNT: 283

### Package Information

For the latest package outline information and land patterns (footprints), go to [www.maximintegrated.com/packages](http://www.maximintegrated.com/packages). Note that a "+", "#", or "-" in the package code indicates RoHS status only. Package drawings may show a different suffix character, but the drawing pertains to the package regardless of RoHS status.

PACKAGE TYPE	PACKAGE CODE	OUTLINE NO.	LAND PATTERN NO.
3 SOT23	U3+1	<a href="#">21-0151</a>	<a href="#">90-0179</a>

## Revision History

REVISION NUMBER	REVISION DATE	DESCRIPTION	PAGES CHANGED
2	4/14	No IV OPNs; Removed Automotive reference from <i>Applications</i> section	1

For pricing, delivery, and ordering information, please contact Maxim Direct at 1-888-629-4642, or visit Maxim Integrated's website at [www.maximintegrated.com](http://www.maximintegrated.com).

*Maxim Integrated cannot assume responsibility for use of any circuitry other than circuitry entirely embodied in a Maxim Integrated product. No circuit patent licenses are implied. Maxim Integrated reserves the right to change the circuitry and specifications without notice at any time. The parametric values (min and max limits) shown in the Electrical Characteristics table are guaranteed. Other parametric values quoted in this data sheet are provided for guidance.*

## Looking for pricing, stock, or lifecycle information?

Click below to explore more details on WIN SOURCE:

 [View MAX6330TUR-T on WIN SOURCE](#)

 [Maxim Integrated](#) Information

## Optimize Your Supply Chain with WIN SOURCE Solutions

-  Global Sourcing Solution
-  Obsolete Management
-  Cost Control Management
-  Shortage Management
-  Alternative Solution
-  Excess Inventory Management