



**THE DATASHEET OF
MAX6452UT26L**



General Description

The MAX6443–MAX6452 low-current microprocessor reset circuits feature single or dual manual reset inputs with an extended setup period. Because of the extended setup period, short switch closures (nuisance resets) are ignored.

On all devices, the reset output asserts when any of the monitored supply voltages drops below its specified threshold. The reset output remains asserted for the reset timeout period (210ms typ) after all monitored supplies exceed their reset thresholds. The reset output is one-shot pulse asserted for the reset timeout period (140ms min) when selected manual reset input(s) are held low for an extended setup timeout period. These devices ignore manual reset transitions of less than the extended setup timeout period.

The MAX6443–MAX6448 are single fixed-voltage µP supervisors. The MAX6443/MAX6444 have a single extended manual reset input. The MAX6445/MAX6446 have two extended manual reset inputs. The MAX6447/MAX6448 have one extended and one immediate manual reset input.

The MAX6449–MAX6452 have one fixed-threshold µP supervisor and one adjustable-threshold µP supervisor. The MAX6449/MAX6450 have two delayed manual reset inputs. The MAX6451/MAX6452 have one delayed and one immediate manual reset input.

The MAX6443–MAX6452 have an active-low $\overline{\text{RESET}}$ with push-pull or open-drain output logic options. These devices, offered in small SOT packages, are fully guaranteed over the extended temperature range (-40°C to +85°C).

Applications

- Set-Top Boxes
- Consumer Electronics
- DVD Players
- Cable/DSL Modems
- MP3 Players
- Industrial Equipment
- Automotive
- Medical Devices

Features

- Single or Dual-Supply Voltage Monitors
- Precision Factory-Set Reset Thresholds from 1.6V to 4.6V
- Adjustable Threshold to Monitor Voltages Down to 0.63V (MAX6449–MAX6452)
- Single or Dual Manual Reset Inputs with Extended Setup Period
- Optional Short Setup Time Manual Reset Input (MAX6447/MAX6448 and MAX6451/MAX6452)
- Immune to Short Voltage Transients
- Low 6µA Supply Current
- Guaranteed Valid Reset Down to $V_{CC} = 1.0V$
- Active-Low $\overline{\text{RESET}}$ (Push-Pull or Open-Drain) Outputs
- 140ms (min) Reset Timeout Period
- Small SOT143 and SOT23 Packages
- AEC-Q100 Qualified (MAX6444US16K/V+T)

Ordering Information at end of data sheet.

Typical Operating Circuit

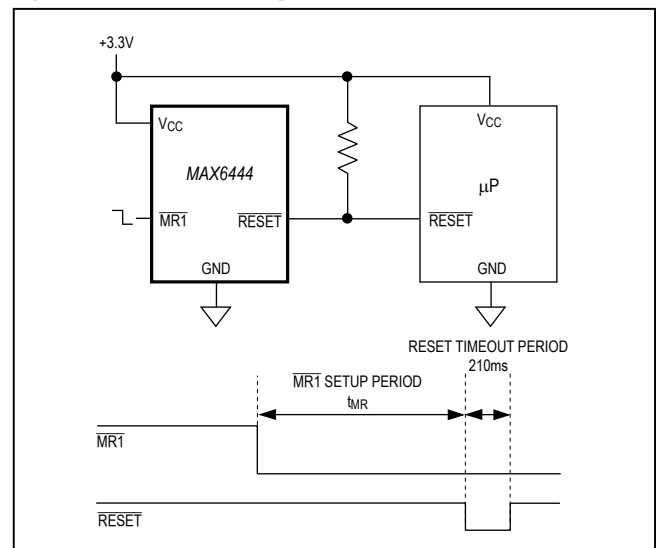

Absolute Maximum Ratings

(All voltages referenced to GND.)

V_{CC}-0.3V to +6V
 Open-Drain RESET-0.3V to +6V
 Push-Pull RESET-0.3V to (V_{CC} + 0.3V)
 MR1, MR2, MR2, RSTIN-0.3V to +6V
 Input Current, All Pins±20mA
 Continuous Power Dissipation (T_A = +70°C)
 4-Pin SOT143 (derate 4.0mW/°C above +70°C)320mW
 5-Pin SOT23 (derate 7.1mW/°C above +70°C)571mW
 6-Pin SOT23 (derate 8.7mW/°C above +70°C)696mW

Operating Temperature Range..... -40°C to +85°C
 Junction Temperature..... +150°C
 Storage Temperature Range..... -65°C to +150°C
 Lead Temperature (soldering, 10s)..... +300°C
 Soldering Temperature (reflow)
 Lead(Pb)-free..... +260°C
 Containing lead..... +240°C

Stresses beyond those listed under “Absolute Maximum Ratings” may cause permanent damage to the device. These are stress ratings only, and functional operation of the device at these or any other conditions beyond those indicated in the operational sections of the specifications is not implied. Exposure to absolute maximum rating conditions for extended periods may affect device reliability.

Electrical Characteristics

(V_{CC} = 1.0V to 5.5V, T_A = -40°C to +85°C, unless otherwise specified. Typical values are at T_A = +25°C.) (Note 1)

PARAMETER	SYMBOL	CONDITIONS	MIN	TYP	MAX	UNITS	
Operating Voltage Range	V _{CC}		1.0		5.5	V	
V _{CC} Supply Current	I _{CC}	V _{CC} = 5.5V, no load		7	20	µA	
		V _{CC} = 3.6V, no load		6	16		
V _{CC} Reset Threshold	V _{TH}	46	4.50	4.63	4.75	V	
		44	4.25	4.38	4.50		
		31	3.00	3.08	3.15		
		29	2.85	2.93	3.00		
		26	2.55	2.63	2.70		
		23	2.25	2.32	2.38		
		22	2.12	2.19	2.25		
		17	1.62	1.67	1.71		
16	1.52	1.58	1.62				
Reset Threshold Tempco				60		ppm/°C	
Reset Threshold Hysteresis				2 × V _{TH}		mV	
RSTIN Threshold	V _{TH-RSTIN}	MAX6449–MAX6452	T _A = 0°C to +85°C	0.615	0.630	0.645	V
			T _A = -40°C to +85°C	0.610		0.650	
RSTIN Threshold Hysteresis	V _{HYST}	MAX6449–MAX6452		2.5		mV	
RSTIN Input Current	I _{RSTIN}	MAX6449–MAX6452	-25		+25	nA	
RSTIN to Reset Output Delay		MAX6449–MAX6452, V _{RSTIN} falling at 1mV/µs		15		µs	
Reset Timeout Period	t _{RP}		140	210	280	ms	
V _{CC} to RESET Output Delay	t _{RD}	V _{CC} falling at 1mV/µs		20		µs	
Manual Reset Minimum Setup Period Pulse Width	t _{MR}	K	6.72	10.08	13.44	s	
		L	4.48	6.72	8.96		
		S	2.24	3.36	4.48		
		T	1.12	1.68	2.24		

Electrical Characteristics (continued)(V_{CC} = 1.0V to 5.5V, T_A = -40°C to +85°C, unless otherwise specified. Typical values are at T_A = +25°C.) (Note 1)

PARAMETER	SYMBOL	CONDITIONS	MIN	TYP	MAX	UNITS
MR2 Minimum Setup Period Pulse Width		MAX6447/MAX6448/MAX6451/MAX6452	1			μs
MR2 Glitch Rejection		MAX6447/MAX6448/MAX6451/MAX6452		100		ns
MR2 to $\overline{\text{RESET}}$ Delay		MAX6447/MAX6448/MAX6451/MAX6452		200		ns
Manual Reset Timeout Period	t _{MRP}		140	210	280	ms
$\overline{\text{MR1}}$ to V _{CC} Pullup Impedance			25	50	75	kΩ
$\overline{\text{MR2}}$ to V _{CC} Pullup Impedance		MAX6445/MAX6446/MAX6449/MAX6450	25	50	75	kΩ
$\overline{\text{RESET}}$ Output Low (Open Drain or Push-Pull)	V _{OL}	V _{CC} ≥ 1.00V, I _{SINK} = 50μA, $\overline{\text{RESET}}$ asserted			0.3	V
		V _{CC} ≥ 1.20V, I _{SINK} = 100μA, $\overline{\text{RESET}}$ asserted			0.3	
		V _{CC} ≥ 2.55V, I _{SINK} = 1.2mA, $\overline{\text{RESET}}$ asserted			0.3	
		V _{CC} ≥ 4.25V, I _{SINK} = 3.2mA, $\overline{\text{RESET}}$ asserted			0.4	
$\overline{\text{RESET}}$ Output High (Push-Pull)	V _{OH}	V _{CC} ≥ 1.80V, I _{SOURCE} = 200μA, $\overline{\text{RESET}}$ deasserted	0.8 × V _{CC}			V
		V _{CC} ≥ 3.15V, I _{SOURCE} = 500μA, $\overline{\text{RESET}}$ deasserted	0.8 × V _{CC}			
		V _{CC} ≥ 4.75V, I _{SOURCE} = 800μA, $\overline{\text{RESET}}$ deasserted	0.8 × V _{CC}			
$\overline{\text{RESET}}$ Open-Drain Leakage Current	I _{LKG}	$\overline{\text{RESET}}$ deasserted			1	μA
$\overline{\text{MR1}}$, $\overline{\text{MR2}}$, MR2 Input Low Voltage	V _{IL}			0.3 × V _{CC}		V
$\overline{\text{MR1}}$, $\overline{\text{MR2}}$, MR2 Input High Voltage	V _{IH}		0.7 × V _{CC}			V

Note 1: Devices production tested at T_A = +25°C. Overtemperature limits are guaranteed by design.

Typical Operating Characteristics

(V_{CC} = 3.3V, T_A = +25°C, unless otherwise noted.)

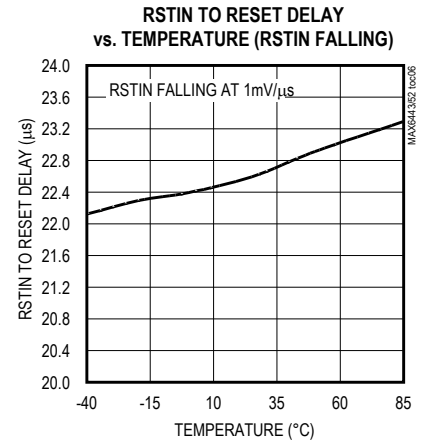
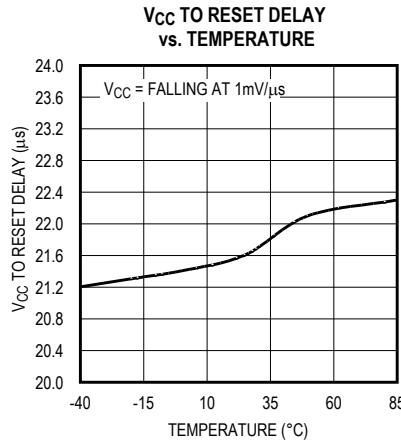
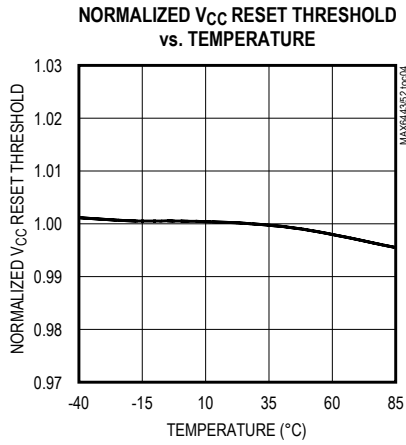
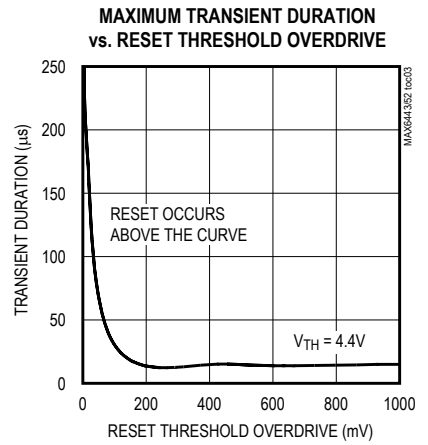
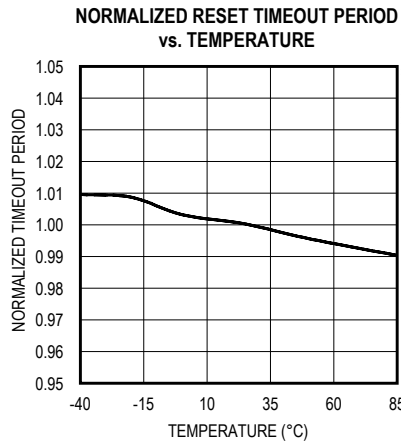
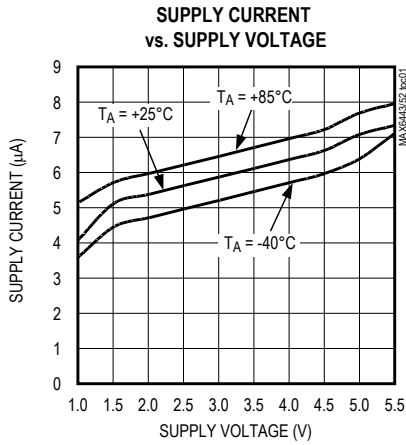

MANUAL RESET TO RESET DELAY (MAX6445L/MAX6446L/MAX6449L/MAX6450L)

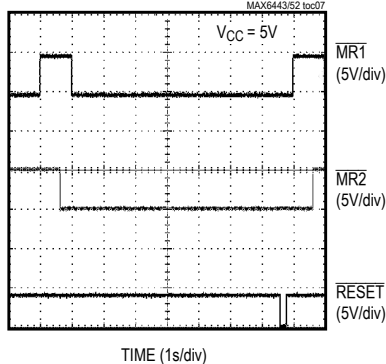

V_{CC} TO RESET DELAY

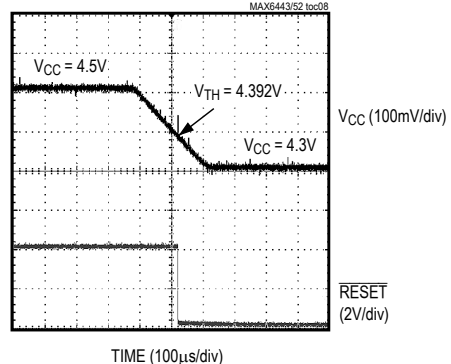

Pin Description

PIN					NAME	FUNCTION
MAX6443 MAX6444	MAX6445 MAX6446	MAX6447 MAX6448	MAX6449 MAX6450	MAX6451 MAX6452		
1	2	2	2	2	GND	Ground
2	1	1	1	1	$\overline{\text{RESET}}$	Active-Low Push-Pull or Open-Drain Output. $\overline{\text{RESET}}$ changes from high to low when V_{CC} or RSTIN drops below its selected reset threshold and remains low for the 210ms reset timeout period after all monitored power-supply inputs exceed their selected reset thresholds. $\overline{\text{RESET}}$ is one-shot pulsed low for the reset timeout period (140ms min) after selected manual reset inputs are asserted longer than the specified setup period. For the open-drain output, use a minimum 20kΩ pullup resistor to V_{CC} .
3	—	3	—	3	$\overline{\text{MR1}}$	Manual Reset Input, Active Low. Internal 50kΩ pullup to V_{CC} . Pull $\overline{\text{MR1}}$ low for the typical input pulse width (t_{MR}) to one-shot pulse $\overline{\text{RESET}}$ for the reset timeout period.
—	3	—	3	—		Manual Reset Input, Active Low. Pull both $\overline{\text{MR1}}$ and $\overline{\text{MR2}}$ low for the typical input pulse width (t_{MR}) to one-shot pulse $\overline{\text{RESET}}$ for the reset timeout period.
4	4	4	4	4	V_{CC}	V_{CC} Voltage Input. Power supply and input for the primary microprocessor voltage reset monitor.
—	5	—	6	—	$\overline{\text{MR2}}$	Manual Reset Input, Active Low. Internal 50kΩ pullup to V_{CC} . Pull both $\overline{\text{MR1}}$ and $\overline{\text{MR2}}$ low for the typical input pulse width (t_{MR}) to one-shot pulse $\overline{\text{RESET}}$ for the reset timeout period.
—	—	5	—	6	MR2	Manual Reset Input. Pull the MR2 high to immediately one-shot pulse $\overline{\text{RESET}}$ for the reset timeout period.
—	—	—	5	5	RSTIN	Reset Input. High-impedance input to the adjustable reset comparator. Connect RSTIN to the center point of an external resistor-divider to set the threshold of the externally monitored voltage.

Detailed Description

Reset Output

The reset output is typically connected to the reset input of a microprocessor (μP). A μP's reset input starts or restarts the μP in a known state. The MAX6443–MAX6452 μP supervisory circuits provide the reset logic to prevent code-execution errors during power-up, power-down and brownout conditions (see the *Typical Operating Circuit*).

$\overline{\text{RESET}}$ changes from high to low whenever the monitored voltages (RSTIN or V_{CC}) drop below the reset

threshold voltages. Once V_{RSTIN} and V_{CC} exceed their respective reset threshold voltages, $\overline{\text{RESET}}$ remains low for the reset timeout period and then goes high. $\overline{\text{RESET}}$ is one-shot pulsed whenever selected manual reset inputs are asserted. $\overline{\text{RESET}}$ stays asserted for the normal reset timeout period (140ms min).

$\overline{\text{RESET}}$ is guaranteed to be in the proper output logic state for V_{CC} inputs $\geq 1V$. For applications requiring valid reset logic when V_{CC} is less than 1V, see the *Ensuring a Valid $\overline{\text{RESET}}$ Output Down to $V_{CC} = 0V$* section.

Manual Reset Input Options

Unlike typical manual reset functions associated with supervisors, each device in the MAX6443–MAX6452 family includes at least one manual reset input, which must be held logic-low for an extended setup period (t_{MR}) before the \overline{RESET} output asserts. When valid manual reset input conditions/setup periods are met, the \overline{RESET} output is one-shot pulse asserted low for a fixed reset timeout period (140ms min). Existing front-panel pushbutton switches (i.e., power on/off, channel up/down, or mode select) can be used to drive the manual reset inputs. The extended manual reset setup period prevents nuisance system resets during normal front-panel usage or resulting from inadvertent short-term pushbutton closure.

The MAX6443/MAX6444, MAX6447/MAX6448, and MAX6451/MAX6452 include a single manual reset input with extended setup period ($\overline{MR1}$). The MAX6445/MAX6446 and MAX6449/MAX6450 include two manual reset inputs ($\overline{MR1}$ and $\overline{MR2}$) with extended setup periods. For dual $\overline{MR1}$, $\overline{MR2}$ devices, both inputs must be held low simultaneously for the extended setup period (t_{MR}) before the reset output is pulse asserted. The dual extended setup provides greater protection from nuisance resets. (For example, the user or service technician is informed to simultaneously push both the on/off button and the channel-select button for 6.72s (L suffix) to reset the system.)

The MAX6443/MAX6452 \overline{RESET} output is pulse asserted once for the reset timeout period after each valid manual reset input condition. At least one manual reset input must be released (go high) and then be driven low for the extended setup period before \overline{RESET} asserts again. Internal timing circuitry debounces low-to-high manual reset logic transitions, so no external circuitry is required. Figure 1 illustrates the single manual reset function of the MAX6443/MAX6444 single-voltage monitors, and Figure 2 represents the dual manual reset function of the MAX6445/MAX6446 and MAX6449/MAX6450.

The MAX6447/MAX6448 and MAX6451/MAX6452 include both an extended setup period and immediate setup period manual reset inputs. A low-to-high $\overline{MR2}$ rising edge transition immediately pulse asserts the \overline{RESET} output for the reset timeout period (140ms min). If the MAX6447/MAX6448 and MAX6451/MAX6452 $\overline{MR2}$ input senses another rising edge before the end of the 140ms timeout period (Figure 3), the internal timer clears and begins counting again. If no rising edges are detected within the 210ms timeout period, \overline{RESET} deasserts. The high-to-low transition on $\overline{MR2}$ input is internally debounced for 210ms to ensure that

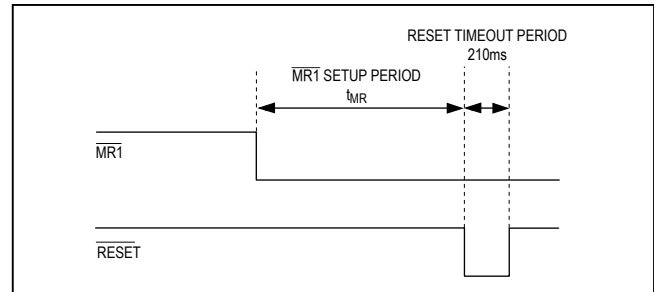

Figure 1. MAX6443/MAX6444 Manual Reset Timing Diagram

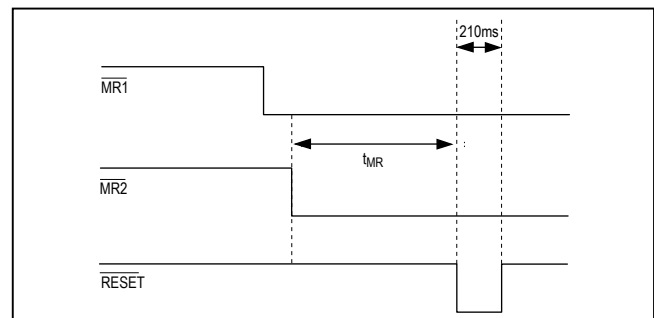

Figure 2. MAX6445/MAX6446/MAX6449/MAX6450 Manual Reset Timing Diagram

there are no false \overline{RESET} assertions when $\overline{MR2}$ is driven from high to low (Figure 4). The $\overline{MR2}$ input can be used for system test purposes or smart-card-detect applications (see the *Applications Information* section).

Adjustable Input Voltage (RSTIN)

The MAX6449–MAX6452 monitor the voltage on RSTIN using an adjustable reset threshold set with an external resistor voltage-divider (Figure 5). Use the following formula to calculate the externally monitored voltage (V_{MON-TH}):

$$V_{MON-TH} = V_{TH-RSTIN} \times (R1 + R2)/R2$$

where V_{MON-TH} is the desired reset threshold voltage and $V_{TH-RSTIN}$ is the reset input threshold (0.63V). Resistors $R1$ and $R2$ can have very high values to minimize current consumption because of low leakage currents. Set $R2$ to some conveniently high value (250k Ω , for example), and calculate $R1$ based on the desired reset threshold voltage, using the following formula:

$$R1 = R2 \times (V_{MON-TH}/V_{TH-RSTIN} - 1) \Omega$$

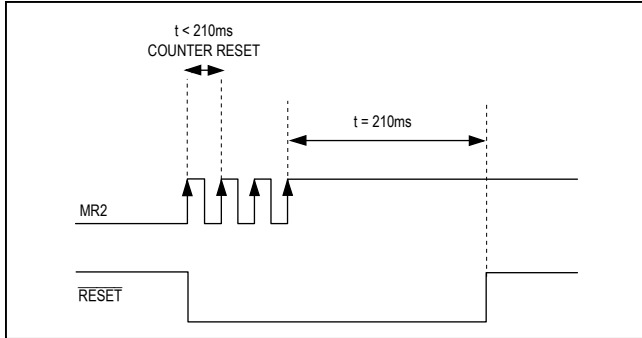

Figure 3. MAX6447/MAX6448/MAX6451/MAX6452 MR2 Assertion Debouncing Timing Diagram

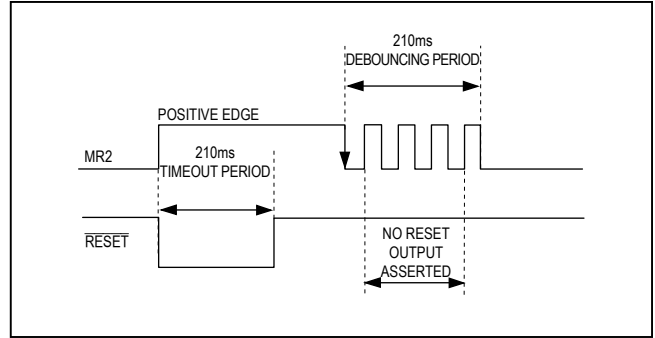

Figure 4. MAX6447/MAX6448/MAX6451/MAX6452 MR2 Deassertion Debouncing Timing Diagram

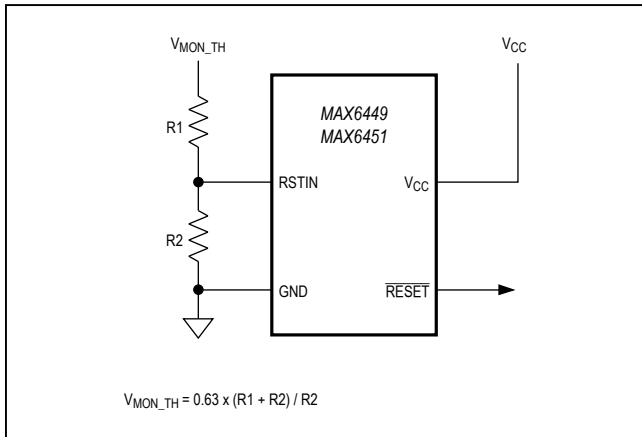

Figure 5. Calculating the Monitored Threshold Voltages

Applications Information

Interrupt Before Reset

To minimize data loss and speed system recovery, many applications interrupt the processor or reset only portions of the system before a processor hard reset is asserted. The extended setup time of the MAX6443–MAX6452 manual reset inputs allows the same pushbutton (connected to both the processor interrupt and the extended $\overline{MR1}$ input, as shown in Figure 6) to control both the interrupt and hard reset functions. If the pushbutton is closed for less than t_{MR} , the processor is only interrupted. If the system still does not respond properly, the pushbutton (or two buttons for the dual manual reset) can be closed for the full extended setup period to hard reset the processor. If desired, connect an LED to the \overline{RESET} output to blink off (or on) for the reset timeout period to signify when the pushbutton is

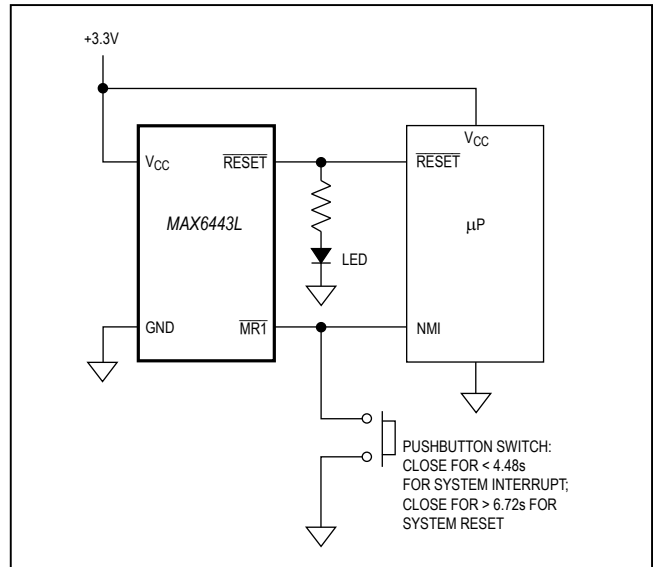

Figure 6. Interrupt Before Reset Application Circuit

closed long enough for a hard reset (the same LED might be used as the front-panel power-on display).

Smart Card Insertion/Removal

The MAX6447/MAX6448/MAX6451/MAX6452 dual manual resets are useful in applications in which both an extended and immediate setup periods are needed. Figure 7 illustrates the insertion and removal of a smart card. $\overline{MR1}$ monitors a front-panel pushbutton. When closed for t_{MR} , \overline{RESET} one-shot pulses low for 140ms min. Because $\overline{MR1}$ is internally pulled to V_{CC} through a 50kΩ resistor, the front-panel switch can be connected to a microprocessor for general-purpose I/O control. $\overline{MR2}$ monitors a switch to detect when a smart card is inserted. When the switch is closed high (card inserted),

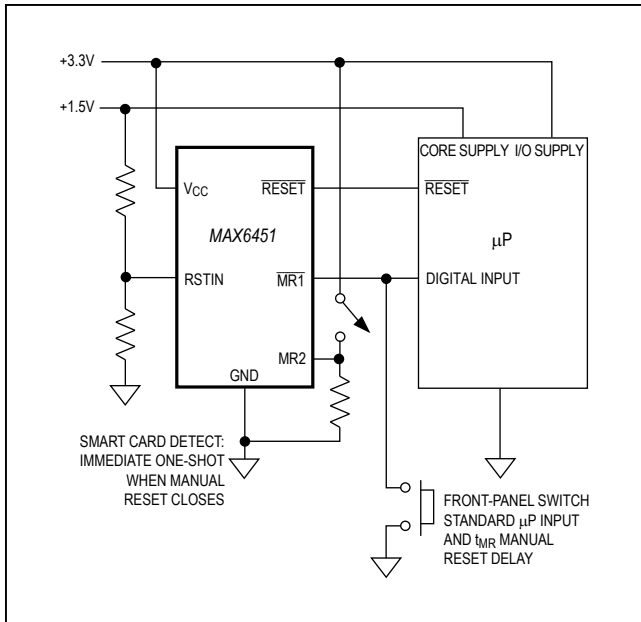

Figure 7. MAX6451/MAX6452 Application Circuit

$\overline{\text{RESET}}$ one-shot pulses low for 140ms. MR2 is internally debounced for 210ms to prevent false resets when the smart card is removed.

Interfacing to Other Voltages for Logic Compatibility

The open-drain $\overline{\text{RESET}}$ output can be used to interface to a μP with other logic levels. As shown in Figure 8, the open-drain output can be connected to voltages from 0 to 6V.

Generally, the pullup resistor connected to the $\overline{\text{RESET}}$ connects to the supply voltage that is being monitored at the IC's V_{CC} pin. However, some systems may use the open-drain output to level-shift from the monitored supply to reset circuitry powered by some other supply (Figure 8). Keep in mind that as the supervisor's V_{CC} decreases toward 1V, so does the IC's ability to sink current at $\overline{\text{RESET}}$. $\overline{\text{RESET}}$ is pulled high as V_{CC} decays toward 0. The voltage where this occurs depends on the pullup resistor value and the voltage to which it is connected.

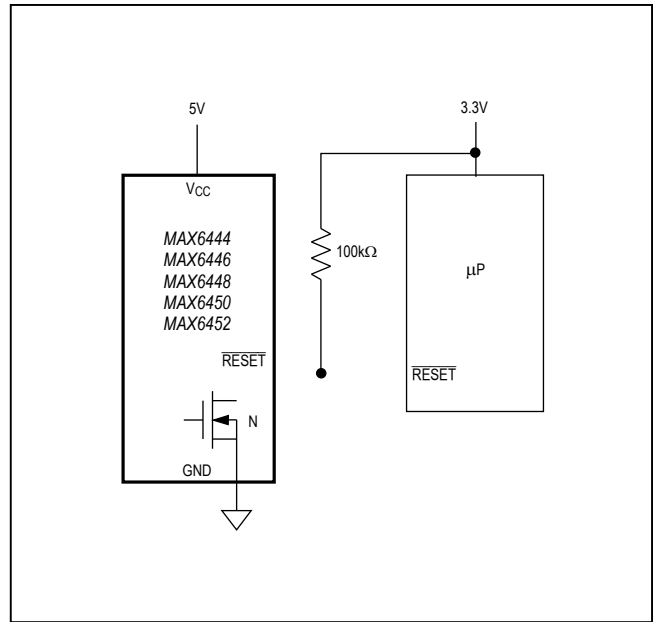

Figure 8. Interfacing to Other Voltage Levels

Ensuring a Valid $\overline{\text{RESET}}$ Down to $V_{CC} = 0V$ (Push-Pull $\overline{\text{RESET}}$)

When V_{CC} falls below 1V, $\overline{\text{RESET}}$ current-sinking capabilities decline drastically. The high-impedance CMOS-logic inputs connected to $\overline{\text{RESET}}$ can drift to undetermined voltages. This presents no problems in most applications, because most μPs and other circuitry do not operate with V_{CC} below 1V.

In applications in which $\overline{\text{RESET}}$ must be valid down to 0V, add a pulldown resistor between $\overline{\text{RESET}}$ and GND for the push-pull outputs. The resistor sinks any stray leakage currents, holding $\overline{\text{RESET}}$ low (Figure 9). The value of the pulldown resistor is not critical; 100kΩ is large enough not to load $\overline{\text{RESET}}$ and small enough to pull $\overline{\text{RESET}}$ to ground. The external pulldown cannot be used with the open-drain reset outputs.

Transient Immunity

In addition to issuing a reset to the μP during power-up, power-down, and brownout conditions, these supervisors are relatively immune to short-duration falling transients (glitches). The graph Maximum Transient Duration vs. Reset Threshold Overdrive in the *Typical Operating Characteristics* section shows this relationship.

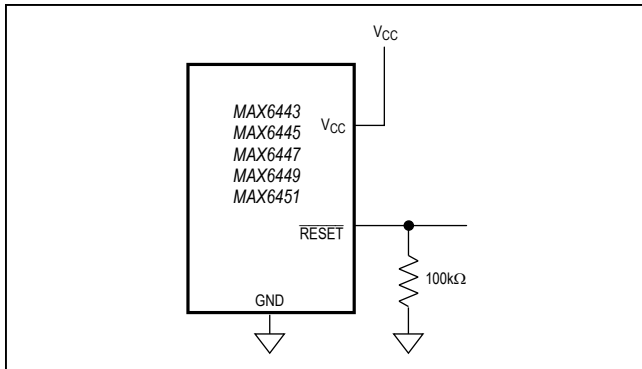

Figure 9. Ensuring \overline{RESET} Valid to $V_{CC} = 0V$

The area below the curves of the graph is the region in which these devices typically do not generate a reset pulse. This graph was generated using a falling pulse applied to V_{CC} , starting above the actual reset threshold (V_{TH}) and ending below it by the magnitude indicated (reset threshold overdrive). As the magnitude of the transient increases (V_{CC} goes further below the reset threshold), the maximum allowable pulse width decreases. Typically, a V_{CC} transient that goes 100mV below the reset threshold and lasts 20μs or less does not cause a reset pulse to be asserted.

Table 1. Reset Voltage Threshold

PART NO. SUFFIX (_ _)	VCC NOMINAL VOLTAGE THRESHOLD (V)
46	4.625
44	4.375
31	3.075
29	2.925
26	2.625
23	2.313
22	2.188
17	1.665
16	1.575

Table 2. Manual Reset Setup Period (t_{MR})

PART NO. SUFFIX (_)	MANUAL RESET SETUP PERIOD (s)
K	10.08
L	6.72
S	3.36
T	1.68

Pin Configurations (continued)

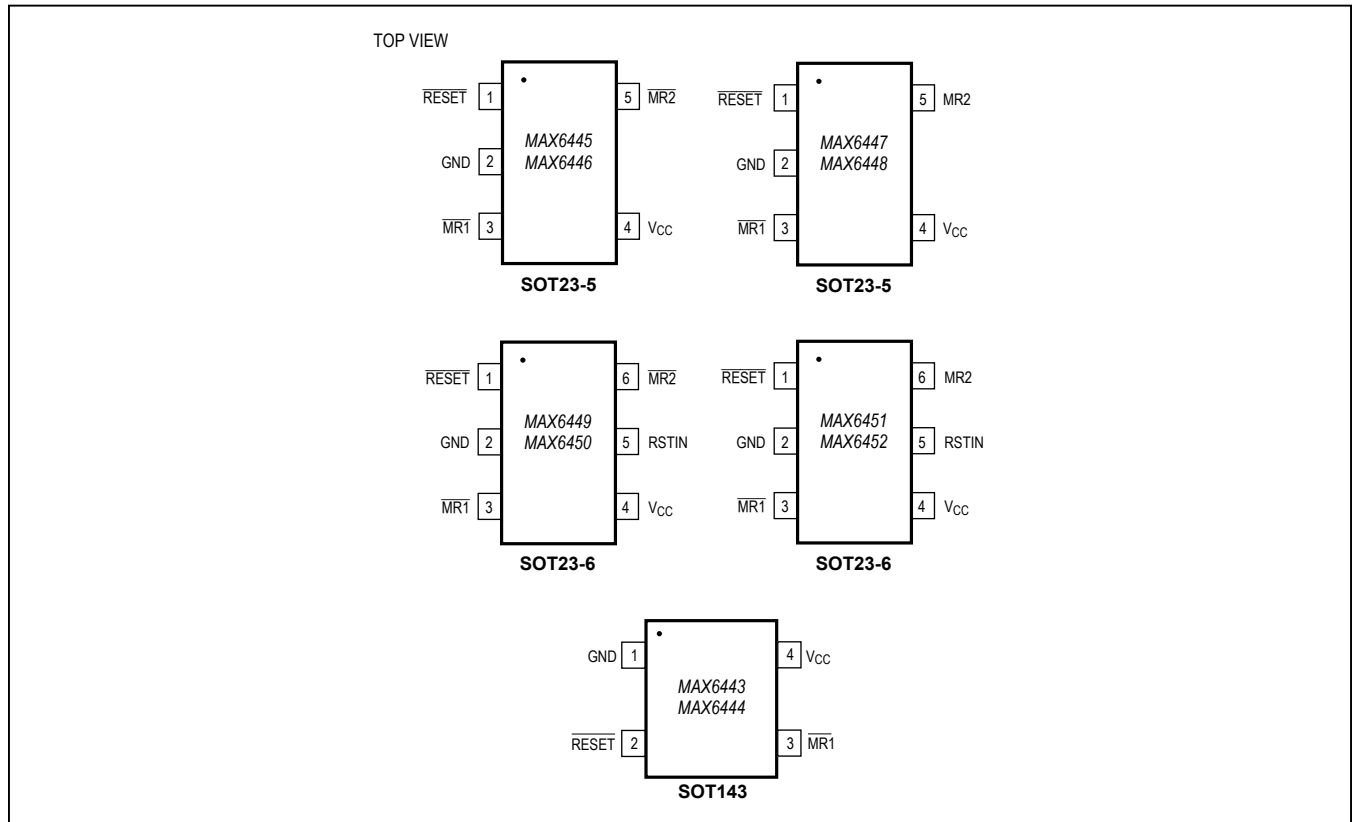

Ordering Information

PART	TEMP RANGE	PIN-PACKAGE
MAX6443US__+T	-40°C to +85°C	4 SOT143
MAX6444US__+T	-40°C to +85°C	4 SOT143
MAX6444US__/V+T*	-40°C to +85°C	4 SOT143
MAX6444US16K/V+T	-40°C to +85°C	4 SOT143
MAX6445UK__+T	-40°C to +85°C	5 SOT23
MAX6446UK__+T	-40°C to +85°C	5 SOT23
MAX6447UK__+T	-40°C to +85°C	5 SOT23
MAX6448UK__+T	-40°C to +85°C	5 SOT23
MAX6449UT__+T	-40°C to +85°C	6 SOT23
MAX6450UT__+T	-40°C to +85°C	6 SOT23
MAX6451UT__+T	-40°C to +85°C	6 SOT23
MAX6452UT__+T	-40°C to +85°C	6 SOT23

Note: The first “__” is a placeholder for the threshold voltage level of the devices. A desired threshold level is set by the two-number suffix found in Table 1. The third “_” is a placeholder for the manual reset setup period of the devices. A desired setup period is set by the letter suffix found in Table 2. All devices are available in tape-and-reel only. There is a 2500-piece minimum order increment for standard versions (Table 2). Sample stock is typically held on standard versions only. Nonstandard versions require a minimum order increment of 10,000 pieces. Contact factory for availability. Most devices are available in lead(Pb)-free packaging only. See Ordering Information for devices available in both leaded and lead(Pb)-free packaging. /V denotes an automotive qualified part. *Future product—contact factory for availability. +Denotes Lead(Pb)-free packages and - denotes leaded packages. For top mark information, please go to <https://www.maximintegrated.com/en/design/packaging/topmark/>.

Selector Guide

PART	$\overline{MR1}$ EXT. SETUP	MR2 (NO SETUP)	$\overline{MR2}$ EXT. SETUP	RSTIN	PUSH-PULL \overline{RESET}	OPEN-DRAIN \overline{RESET}
MAX6443	✓	—	—	—	✓	—
MAX6444	✓	—	—	—	—	✓
MAX6445	✓	—	✓	—	✓	—
MAX6446	✓	—	✓	—	—	✓
MAX6447	✓	✓	—	—	✓	—
MAX6448	✓	✓	—	—	—	✓
MAX6449	✓	—	✓	✓	✓	—
MAX6450	✓	—	✓	✓	—	✓
MAX6451	✓	✓	—	✓	✓	—
MAX6452	✓	✓	—	✓	—	✓

Functional Diagram

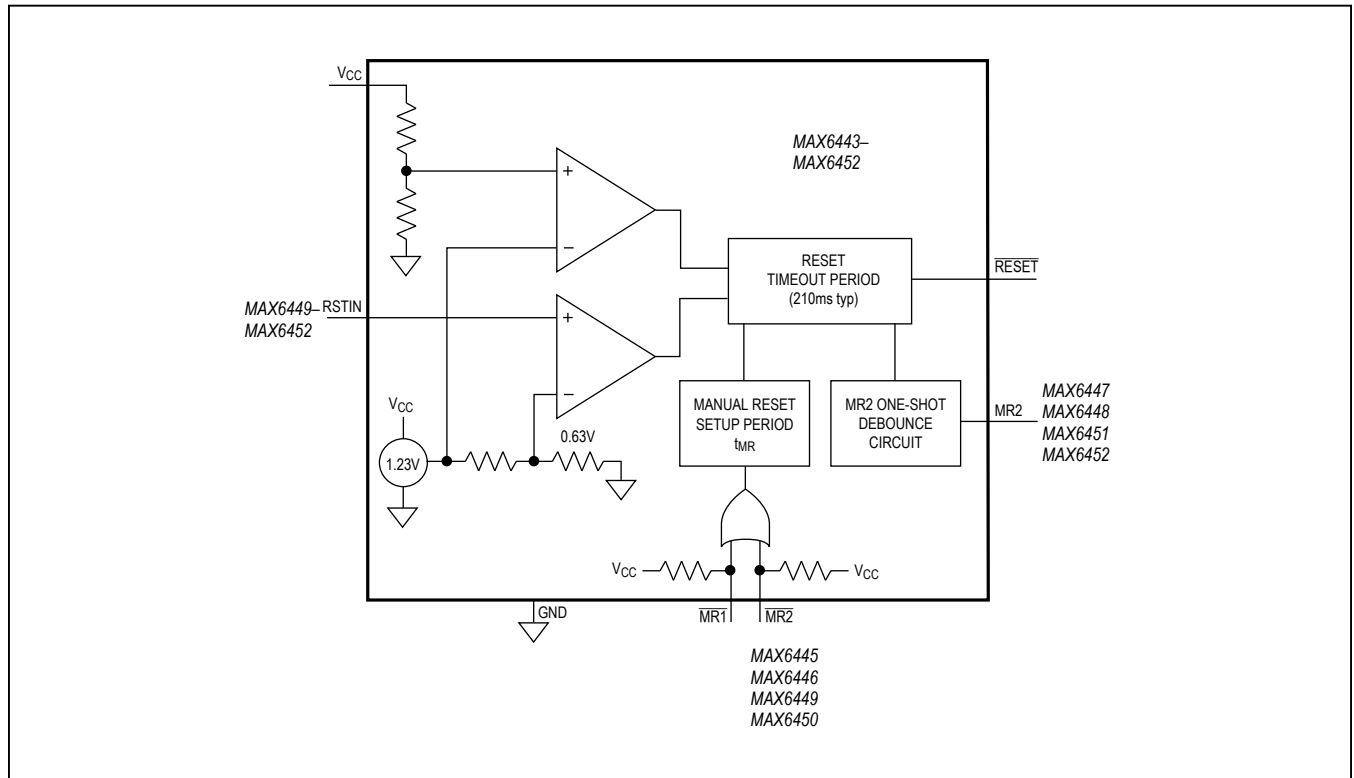

Chip Information

PROCESS: BICMOS

Package Information

For the latest package outline information and land patterns (footprints), go to www.maximintegrated.com/packages. Note that a "+", "#", or "-" in the package code indicates RoHS status only. Package drawings may show a different suffix character, but the drawing pertains to the package regardless of RoHS status.

PACKAGE TYPE	PACKAGE CODE	OUTLINE NO.	LAND PATTERN NO.
4 SOT143	U4+1	21-0052	90-0183
5 SOT23	U5+1, U5-1	21-0057	90-0174
6 SOT23	U6+1	21-0058	90-0175

Revision History

REVISION NUMBER	REVISION DATE	DESCRIPTION	PAGES CHANGED
0	10/02	Initial release	—
3	6/10	Revised the <i>General Description, Features, Applications, Ordering Information, Absolute Maximum Ratings, Electrical Characteristics, Typical Operating Characteristics, Pin Description</i> , the <i>Manual Reset Input Options, Interrupt Before Reset</i> , and <i>Smart Card Insertion/Removal</i> sections, <i>Functional Diagram, Typical Operating Circuit, Selector Guide</i> , Figures 1, 6, and 7, as well as Tables 2 and 3 to add extended setup timeout specifications	1, 2, 4, 5–12
4	3/14	Added the automotive MAX6444US___/V+T to the <i>Ordering Information</i> table	1
5	12/15	Added lead-free package part numbers, removed top mark table and added reference to top mark information on website	1, 10, 12
6	3/18	Updated <i>Ordering Information</i> table and <i>Benefits and Features</i> section	1, 10

For pricing, delivery, and ordering information, please contact Maxim Direct at 1-888-629-4642, or visit Maxim Integrated's website at www.maximintegrated.com.

Maxim Integrated cannot assume responsibility for use of any circuitry other than circuitry entirely embodied in a Maxim Integrated product. No circuit patent licenses are implied. Maxim Integrated reserves the right to change the circuitry and specifications without notice at any time. The parametric values (min and max limits) shown in the *Electrical Characteristics* table are guaranteed. Other parametric values quoted in this data sheet are provided for guidance.

Looking for pricing, stock, or lifecycle information?

Click below to explore more details on WIN SOURCE:

 [View MAX6452UT26L on WIN SOURCE](#)

 [Maxim Integrated Information](#)

Optimize Your Supply Chain with WIN SOURCE Solutions

-  Global Sourcing Solution
-  Obsolete Management
-  Cost Control Management
-  Shortage Management
-  Alternative Solution
-  Excess Inventory Management