



**THE DATASHEET OF  
MAX6519UKP105+T**





# Low-Cost, 2.7V to 5.5V, Analog Temperature Sensor Switches in a SOT23

MAX6516-MAX6519

## General Description

The MAX6516-MAX6519 low-cost, fully integrated temperature switches assert a logic signal when their die temperature crosses a factory-programmed threshold. Operating from a 2.7V to 5.5V supply, these devices feature a fixed voltage reference, an analog temperature sensor, and a comparator. They are available with factory-trimmed temperature trip thresholds from -45°C to +115°C in 10°C increments, and are accurate to ±0.5°C (typ). These devices require no external components and typically consume 22µA of supply current. Hysteresis is pin selectable at 2°C or 10°C.

The MAX6516-MAX6519 are offered with hot-temperature thresholds (+35°C to +115°C), asserting when the temperature is above the threshold, or with cold-temperature thresholds (-45°C to +15°C), asserting when the temperature is below the threshold.

These devices provide an analog output proportional to temperature and are stable with any capacitive load up to 1000pF. The MAX6516-MAX6519 can be used over a range of -35°C to +125°C with a supply voltage of 2.7V to 5.5V. For applications sensing temperature down to -45°C, a supply voltage above 4.5V is required.

The MAX6516 and MAX6518 have an active-high, push-pull output. The MAX6517 and MAX6519 have an active-low, open-drain output. These devices are available in a space-saving 5-pin SOT23 package and operate over the -55°C to +125°C temperature range.

## Applications

- |                     |                                  |
|---------------------|----------------------------------|
| Fan Control         | Over/Undertemperature Protection |
| Test Equipment      | Notebook, Desktop PCs            |
| Temperature Control | RAID                             |
| Temperature Alarms  | Servers                          |

## Typical Operating Circuit

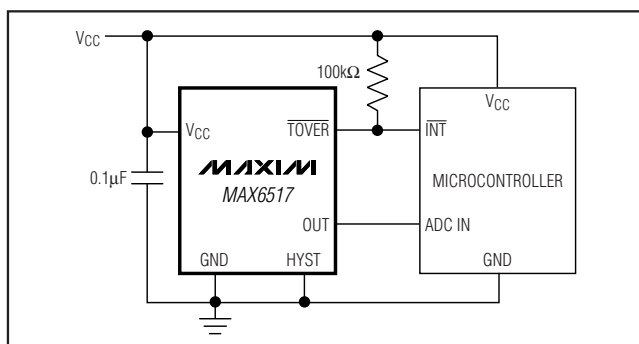

## Features

- ◆ High Accuracy ±1.5°C (max) Over -15°C to +65°C Temperature Range
- ◆ Low Power Consumption—22µA Typical Current
- ◆ Factory-Programmed Thresholds from -45°C to +115°C in 10°C Increments
- ◆ Analog Output to Allow Board-Level Testing
- ◆ Open-Drain or Push-Pull Outputs
- ◆ Pin-Selectable 2°C or 10°C Hysteresis

## Ordering Information

PART	TEMP RANGE	PIN-PACKAGE
MAX6516UK_ _ _ _+T	-55°C to +125°C	5 SOT23
MAX6517UK_ _ _ _+T	-55°C to +125°C	5 SOT23
MAX6518UK_ _ _ _+T	-55°C to +125°C	5 SOT23
MAX6519UK_ _ _ _+T	-55°C to +125°C	5 SOT23

**Note:** These parts are offered in 16 standard temperature versions with a minimum order of 2500 pieces. To complete the suffix information, add P or N for positive or negative trip temperature, and select an available trip point in degrees centigrade. For example, the MAX6516UKP065+T describes a MAX6516 in a 5-pin SOT23 package with a +65°C threshold. Contact the factory for pricing and availability.  
+Denotes a lead(Pb)-free/RoHS-compliant package.  
T = Tape and reel.

Functional Diagram appears at end of data sheet.

## Pin Configurations

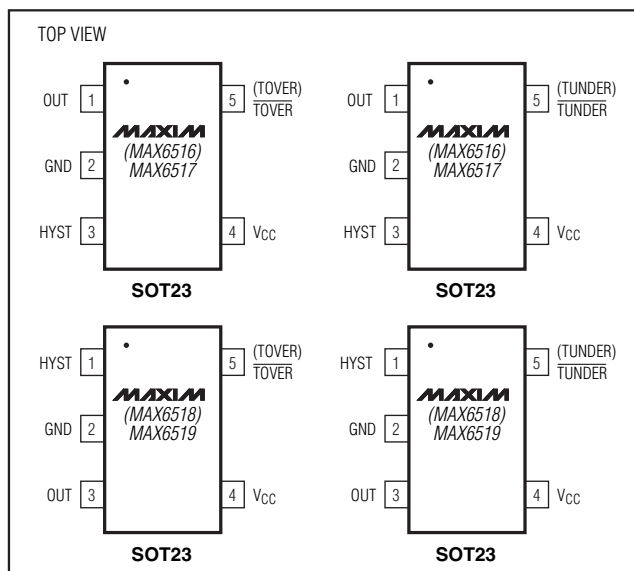

# Low-Cost, 2.7V to 5.5V, Analog Temperature Sensor Switches in a SOT23

## ABSOLUTE MAXIMUM RATINGS

All voltages are referenced to GND.

V <sub>CC</sub> .....	-0.3V to +6V
TOVER, TUNDER (open drain).....	-0.3V to +6V
TOVER, TUNDER (push-pull).....	-0.3V to (V <sub>CC</sub> + 0.3V)
OUT, HYST.....	-0.3V to (V <sub>CC</sub> + 0.3V)
OUT Short to GND.....	Indefinite

Continuous Power Dissipation (T<sub>A</sub> = +70°C)

SOT23 (derate 3.1mW/°C above +70°C).....	247mW
Operating Temperature Range.....	-55°C to +125°C
Junction Temperature.....	+150°C
Storage Temperature Range.....	-65°C to +150°C
Lead Temperature (soldering, 10s).....	+300°C
Soldering Temperature (reflow).....	+260°C

Stresses beyond those listed under "Absolute Maximum Ratings" may cause permanent damage to the device. These are stress ratings only, and functional operation of the device at these or any other conditions beyond those indicated in the operational sections of the specifications is not implied. Exposure to absolute maximum rating conditions for extended periods may affect device reliability.

## ELECTRICAL CHARACTERISTICS

(V<sub>CC</sub> = 2.7V to 5.5V, R<sub>PULLUP</sub> = 100kΩ (open-drain output only), T<sub>A</sub> = -55°C to +125°C, unless otherwise noted. Typical values are at T<sub>A</sub> = +25°C.) (Note 1)

PARAMETER	SYMBOL	CONDITIONS	MIN	TYP	MAX	UNITS
Supply Voltage Range	V <sub>CC</sub>		2.7		5.5	V
Supply Current	I <sub>CC</sub>	Hot-temperature thresholds (+35°C to +115°C)		22	40	μA
		Cold-temperature thresholds (-45°C to +15°C)		40		
Temperature Threshold Accuracy (Note 2)	ΔT <sub>TH</sub>	-15°C to +65°C	-1.5		+1.5	°C
		+75°C to +115°C	-2.5		+2.5	
		-45°C to -25°C (Note 3)	-3		+3	
Temperature Threshold Hysteresis	T <sub>HYST</sub>	HYST = V <sub>CC</sub>		2		°C
		HYST = GND		10		
HYST Input Logic Level (Note 4)	V <sub>IH</sub>		0.8 x V <sub>CC</sub>			V
	V <sub>IL</sub>		0.2 x V <sub>CC</sub>			
Logic Output Voltage High (Push-Pull)	V <sub>OH</sub>	I <sub>SOURCE</sub> = 500μA, V <sub>CC</sub> > 2.7V	0.8 x V <sub>CC</sub>			V
		I <sub>SOURCE</sub> = 800μA, V <sub>CC</sub> > 4.5V	V <sub>CC</sub> - 1.5			
Logic Output Voltage Low (Push-Pull and Open Drain)	V <sub>OL</sub>	I <sub>SINK</sub> = 1.2mA, V <sub>CC</sub> > 2.7V			0.3	V
		I <sub>SINK</sub> = 3.2mA, V <sub>CC</sub> > 4.5V			0.4	
Open-Drain Output Leakage Current		V <sub>CC</sub> = 2.7V, open-drain output = 5.5V		10		nA
<b>OUT TEMPERATURE SENSITIVITY</b>						
Error to Equation: OUT = 1.8015V - 10.62mV(T - 30) - 1.1μV (T - 30) <sup>2</sup>		-30°C to +125°C, V <sub>CC</sub> = 2.7V to 5.5V	-2		+2	°C
		-55°C to -30°C (Note 3)	-5		+2	
Sensor Gain				-10.62		mV/°C
OUT Capacitive Load (Note 4)					1000	pF
OUT Load Regulation		0 < I <sub>OUT</sub> < 40μA			0.24	°C
		-1μA < I <sub>OUT</sub> < 0			0.02	
OUT Line Regulation				0.04	0.3	°C/V

**Note 1:** 100% production tested at T<sub>A</sub> = +25°C. Specifications over temperature are guaranteed by design.

**Note 2:** The MAX6516-MAX6519 are available with internal factory-programmed temperature trip thresholds from -45°C to +115°C in 10°C increments.

**Note 3:** V<sub>CC</sub> must be greater than 4.5V for a switching threshold of -45°C.

**Note 4:** Guaranteed by design.

# Low-Cost, 2.7V to 5.5V, Analog Temperature Sensor Switches in a SOT23

## Typical Operating Characteristics

( $V_{CC} = 5V$ ,  $T_A = +25^\circ C$ , unless otherwise noted.)

MAX6516-MAX6519

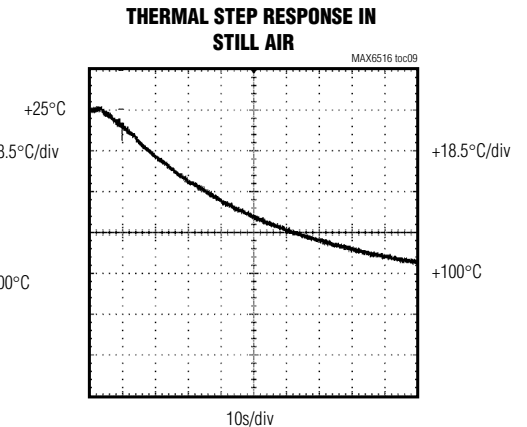
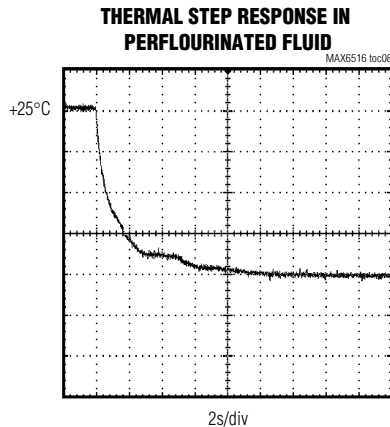
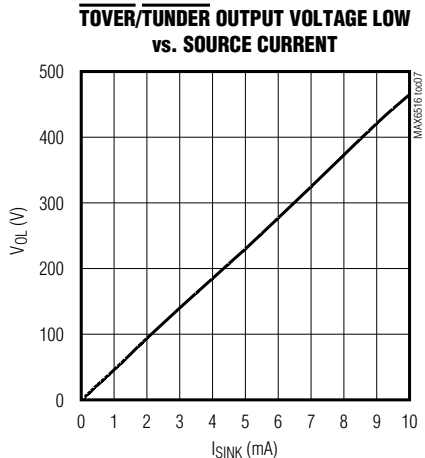
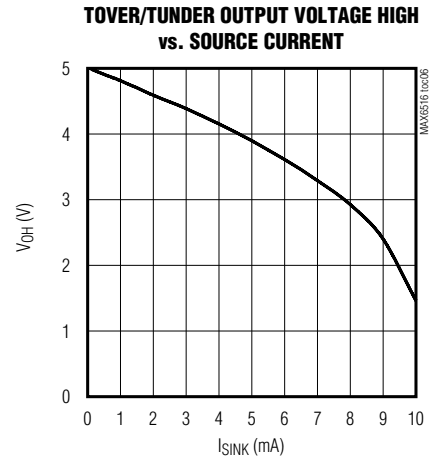
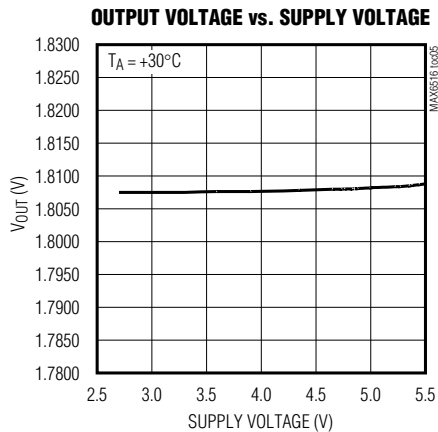
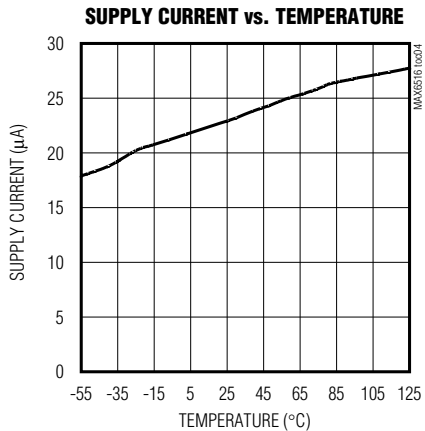
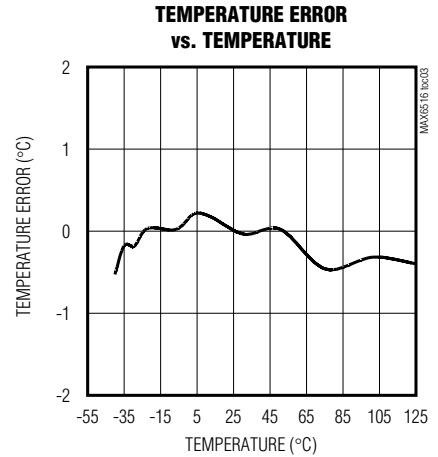
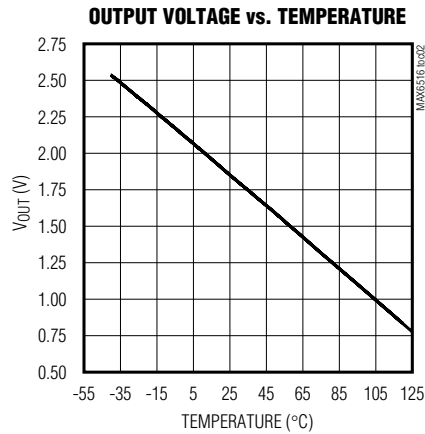
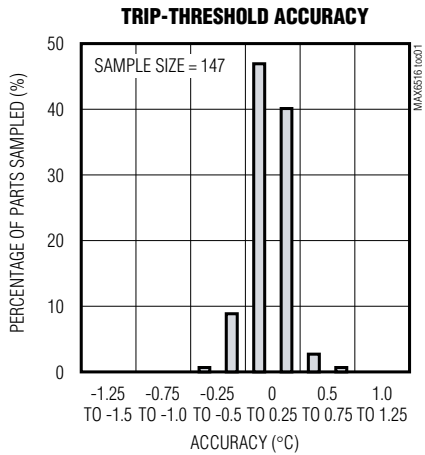

# Low-Cost, 2.7V to 5.5V, Analog Temperature Sensor Switches in a SOT23

## Typical Operating Characteristics (continued)

( $V_{CC} = 5V$ ,  $T_A = +25^\circ C$ , unless otherwise noted.)

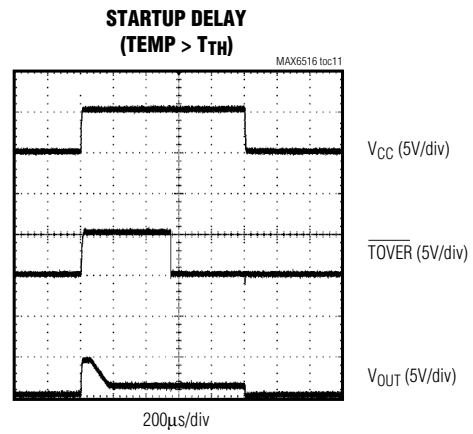
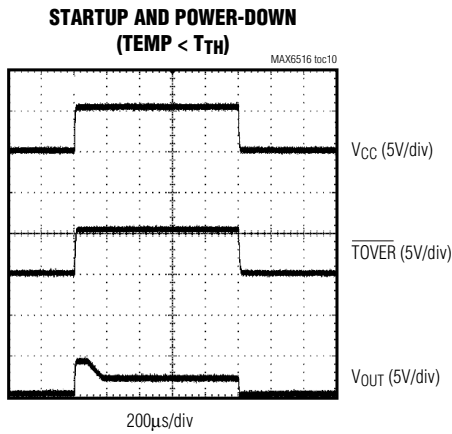

## Pin Description

PIN				NAME	FUNCTION
MAX6516	MAX6517	MAX6518	MAX6519		
1	1	3	3	OUT	Analog Output. Voltage represents the die's temperature.
2	2	2	2	GND	Ground
3	3	1	1	HYST	Hysteresis Input. Connect to $V_{CC}$ for $2^\circ C$ of hysteresis or to GND for $10^\circ C$ hysteresis.
4	4	4	4	$V_{CC}$	Input Supply. Bypass to ground with a $0.1\mu F$ capacitor.
5	—	5	—	TOVER	Push-Pull Active-High Output (Hot Threshold). TOVER goes high when the die temperature exceeds the factory-programmed hot temperature threshold.
—	5	—	5	$\overline{TOVER}$	Open-Drain, Active-Low Output (Hot Threshold). $\overline{TOVER}$ goes low when the die temperature exceeds the factory-programmed hot temperature threshold. Connect to a $100k\Omega$ pullup resistor. May be pulled up to a voltage higher than $V_{CC}$ .
5	—	5	—	TUNDER	Push-Pull Active-High Output (Cold Threshold). TUNDER goes high when the die temperature falls below the factory-programmed cold temperature threshold.
—	5	—	5	$\overline{TUNDER}$	Open-Drain, Active-Low Output (Cold Threshold). $\overline{TUNDER}$ goes low when the die temperature goes below the factory-programmed cold temperature threshold. Connect to a $100k\Omega$ pullup resistor. May be pulled up to a voltage higher than $V_{CC}$ .

# Low-Cost, 2.7V to 5.5V, Analog Temperature Sensor Switches in a SOT23

## Detailed Description

The MAX6516–MAX6519 fully integrated temperature switches incorporate a fixed reference, an analog temperature sensor, and a comparator. The temperature at which the two reference voltages are equal determines the temperature trip point. OUT is an analog voltage that varies with the die's temperature. Pin-selectable 2°C or 10°C hysteresis keeps the digital output from oscillating when the die temperature approaches the threshold temperature. The MAX6516 and MAX6518 have an active-high, push-pull output structure that can sink or source current. The MAX6517 and MAX6519 have an active-low, open-drain output structure that can only sink current. The internal power-on reset circuit guarantees the logic output is at its +25°C state for at least 50μs.

### Analog Output

OUT is an analog output that is proportional to the die temperature. OUT voltage range is between 0.77V to 2.59V, within the temperature range of -45°C to +125°C. For applications with a switching threshold of -45°C, the supply voltage must be greater than 4.5V. The temperature-to-voltage transfer function is approximately linear and can be described by the quadratic equation:

$$V_{OUT} = 1.8015 - 10.62\text{mV} (T - 30) + 1.1\mu\text{V} (T - 30)^2$$

where T = temperature in °C.

In most cases, a linear approximation can be applied:

$$V_{OUT} = 1.8015 - 10.62\text{mV} (T - 30)$$

Therefore,

$$T = \frac{1.8015 - V_{OUT}}{0.01062} + 30^\circ\text{C}$$

### Hysteresis Input

The HYST input selects the devices' temperature hysteresis and prevents the output from oscillating when the temperature approaches the trip point. Connect HYST to V<sub>CC</sub> for 2°C hysteresis or to GND for 10°C hysteresis.

## Logic Temperature Indicators

### Overtemperature Indicator (Hot Thresholds)

TOVER and  $\overline{\text{TOVER}}$  designations apply to thresholds above T<sub>A</sub> = +25°C (+35°C, +45°C, +55°C, +65°C, +75°C, +85°C, +95°C, +105°C, +115°C). All "hot" thresholds are positive temperatures.

The overtemperature indicator output is open-drain active low ( $\overline{\text{TOVER}}$ ) or push-pull active high (TOVER).  $\overline{\text{TOVER}}$  goes low when the die temperature exceeds the factory-programmed temperature threshold.  $\overline{\text{TOVER}}$  should be pulled up to a voltage no greater than 5.5V with a 100kΩ pullup resistor. TOVER is a push-pull active-high CMOS output that goes high when the die temperature exceeds the factory-programmed temperature threshold.

### Undertemperature Indicator (Cold Thresholds)

TUNDER and  $\overline{\text{TUNDER}}$  designations apply to thresholds below T<sub>A</sub> = +25°C (+15°C, +5°C, -5°C, -15°C, -25°C, -35°C, -45°C). The undertemperature indicator output is open drain, active low ( $\overline{\text{TUNDER}}$ ), or push-pull active high (TUNDER).  $\overline{\text{TUNDER}}$  goes low when the die temperature goes below the factory-programmed temperature threshold.  $\overline{\text{TUNDER}}$  should be pulled up to a voltage no greater than 5.5V with a 100kΩ pullup resistor. TUNDER is a push-pull active-high CMOS output that goes high when the die temperature falls below the factory-programmed temperature threshold.

## Applications Information

### Temperature-Window Alarm

The MAX6516/MAX6518 logic outputs assert when the die temperature is outside the factory-programmed range. Combining the outputs of two devices creates an over/undertemperature alarm. Two MAX6516s or two MAX6518s are used to form two complementary pairs, containing one cold trip-point output and one hot trip-point output. The assertion of either output alerts the system to an out-of-range temperature. The MAX6516 push-pull output stages can be ORed to produce a thermal out-of-range alarm (Figure 1).

More favorably, two MAX6517s or two MAX6519s can be directly wire-ORed with a single external resistor to accomplish the same task. The temperature window alarms shown in Figure 2 can be used to accurately determine when a device's temperature falls out of the -5°C to +75°C range. The thermal overrange signal can be used to assert a thermal shutdown, power-up, recalibration, or other temperature-dependent function.

# Low-Cost, 2.7V to 5.5V, Analog Temperature Sensor Switches in a SOT23

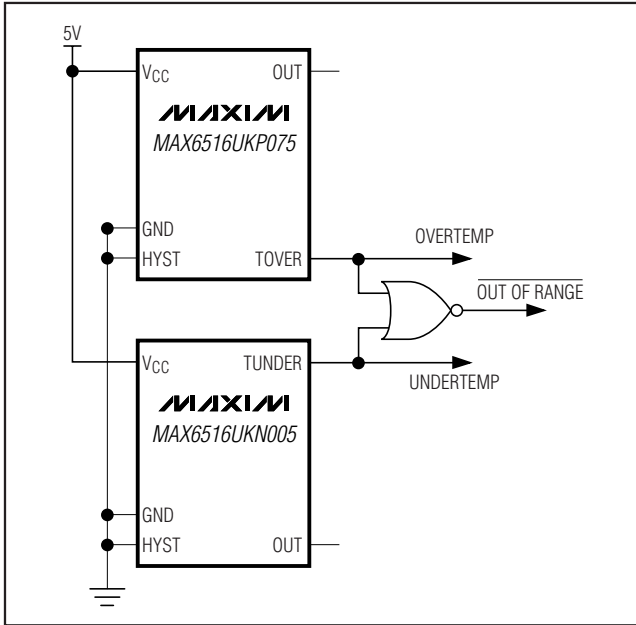

Figure 1. Temperature-Window Alarms Using the MAX6516

### Low-Cost, Fail-Safe Temperature

In high-performance/high-reliability applications, multiple temperature monitoring is important. The high-level integration and low cost of the MAX6516 and MAX6518 facilitate the use of multiple temperature monitors to increase system reliability. The application in Figure 3 uses two MAX6516s with different hot temperature thresholds to ensure that fault conditions that can overheat the monitored device cause no permanent damage. The first temperature monitor activates the fan when the die temperature exceeds +45°C. The second MAX6516 triggers a system shutdown if the die temperature reaches +75°C, preventing damage from a wide variety of destructive fault conditions, including latches, short circuits, and cooling-system failures.

### PC Board Testing

The MAX6516-MAX6519 temp sensor devices can be tested after PC board assembly using OUT. Testing can be used to verify proper assembly and functionality of the temperature protection circuitry. Since OUT has a weak drive capability, the voltage at OUT can be forced to cause the digital outputs to change states, thereby verifying that the internal comparators and output circuitry function properly after assembly. Below is a test procedure that can be used to test the MAX6516-MAX6519:

- Power up the device, measure OUT, and observe the state of the logic output.

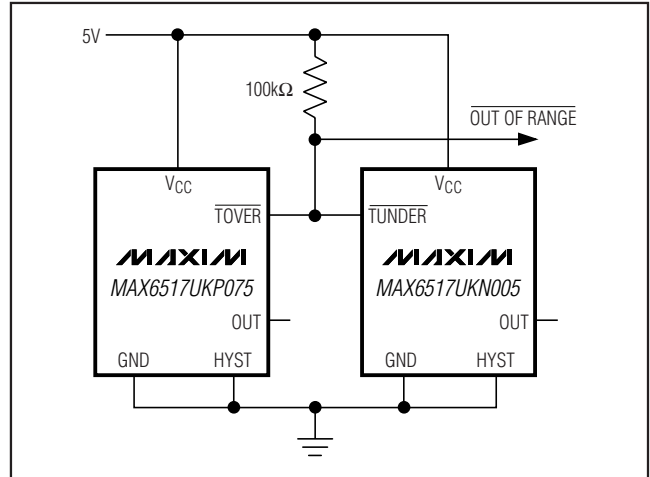

Figure 2. Temperature Window Alarm Using the MAX6517

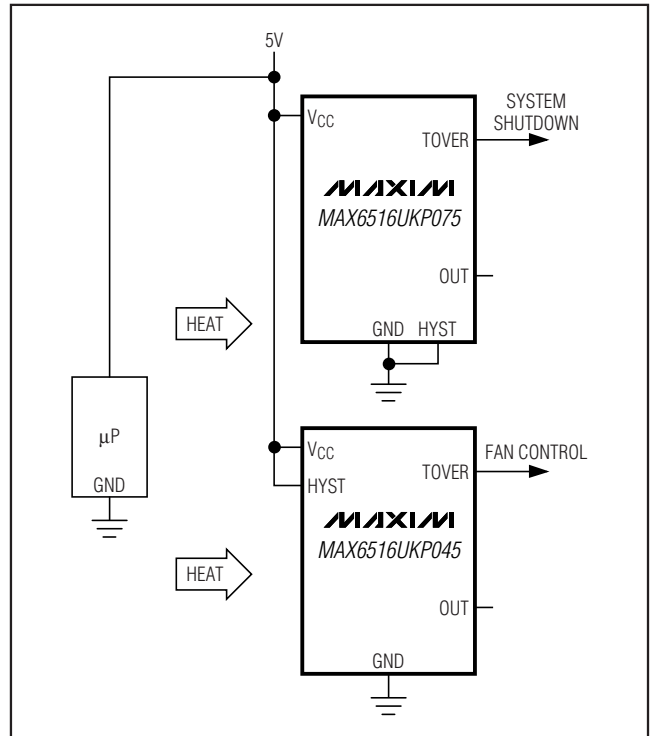

Figure 3. Low-Power, High-Reliability, Fail-Safe Temperature Monitor

## Low-Cost, 2.7V to 5.5V, Analog Temperature Sensor Switches in a SOT23

- Calculate the temperature using the formula:

$$T = \frac{1.8015 - V_{OUT}}{0.01062} + 30$$

- Verify that the temperature measured is within  $\pm 2^\circ\text{C}$  of the ambient board temperature. Measure the ambient board temperature using an accurate calibrated temperature sensor.
- Connect OUT to ground (OUT to  $V_{CC}$  for cold threshold versions) and observe the state change of the logic output.
- Disconnect OUT from ground and observe that the logic output reverts to its initial state.

### Hysteresis Testing

The MAX6516-MAX6519 can be programmed with  $2^\circ\text{C}$  or  $10^\circ\text{C}$  of hysteresis by pin strapping HYST to  $V_{CC}$  or GND, respectively. Below is a test feature that can be used to measure the accuracy of the device's hysteresis using a device with a  $+65^\circ\text{C}$  threshold:

- Power up the device and observe the state of the digital output.
- Drive the OUT voltage down gradually.
- When the digital output changes state, note  $V_{OUT}$ .
- $V_{OUTtrip} = V_{OUT}$  at logic output change of state (high to low or low to high).
- Calculate trip temperature ( $T_1$ ) using:

$$T = \frac{1.8015 - V_{OUT}}{0.01062} + 30$$

- Gradually raise  $V_{OUT}$  until the digital output reverts to its initial state and note  $V_{OUT}$ .
- Calculate trip temperature ( $T_2$ ).
- $T_{HYST} = T_2 - T_1$ .

### Thermal Considerations

The MAX6516-MAX6519 supply current is typically  $22\mu\text{A}$ . When used to drive high-impedance loads, the devices dissipate negligible power. Therefore, the die temperature is essentially the same as the package temperature.

Accurate temperature monitoring depends on the thermal resistance between the device being monitored and the MAX6516-MAX6519 die. Heat flows in and out of plastic packages, primarily through the leads. Pin 2 of the 5-pin SOT23 package provides the lowest thermal resistance to the die. Short, wide copper traces between the MAX6516-MAX6519 and the object whose temperature is being monitored ensures heat transfers occur quickly and reliably. The rise in die temperature due to self-heating is given by the following formula:

$$\Delta T_J = P_{DISSIPATION} \times \theta_{JA}$$

where  $P_{DISSIPATION}$  is the power dissipated by the MAX6516-MAX6519, and  $\theta_{JA}$  is the thermal resistance of the package.

The typical thermal resistance is  $140^\circ\text{C}/\text{W}$  for the 5-pin SOT23 package. To limit the effects of self-heating, minimize the output current. For example, if the MAX6516-MAX6519 sink  $1\text{mA}$ , the open-drain output voltage is guaranteed to be less than  $0.3\text{V}$ . Therefore, an additional  $0.3\text{mW}$  of power is dissipated within the IC. This corresponds to a  $0.042^\circ\text{C}$  shift in the die temperature in the 5-pin SOT23 package.

### Chip Information

PROCESS: BiCMOS

# Low-Cost, 2.7V to 5.5V, Analog Temperature Sensor Switches in a SOT23

Table 1. Top Marks

PART	TOP MARK	PART	TOP MARK
MAX6516UKN045	AEHS	MAX6518UKN045	AELL
MAX6516UKN035	AECZ	MAX6518UKN035	AEDD
MAX6516UKN025	AEHR	MAX6518UKN025	AELK
MAX6516UKN015	AEHQ	MAX6518UKN015	AELJ
MAX6516UKN005	AEHP	MAX6518UKN005	AELI
MAX6516UKP005	AEHT	MAX6518UKP005	AELM
MAX6516UKP015	AEHU	MAX6518UKP015	AELN
MAX6516UKP035	AEHV	MAX6518UKP035	AELO
MAX6516UKP045	AEHW	MAX6518UKP045	AELP
MAX6516UKP055	AEHX	MAX6518UKP055	AELQ
MAX6516UKP065	AEHY	MAX6518UKP065	AELR
MAX6516UKP075	AEDA	MAX6518UKP075	AEDE
MAX6516UKP085	AEHZ	MAX6518UKP085	AELS
MAX6516UKP095	AEIA	MAX6518UKP095	AELT
MAX6516UKP105	AEIB	MAX6518UKP105	AELU
MAX6516UKP115	AEIC	MAX6518UKP115	AELV
MAX6517UKN045	AELZ	MAX6519UKN045	AEIG
MAX6517UKN035	AEDB	MAX6519UKN035	AEDF
MAX6517UKN025	AELY	MAX6519UKN025	AEIF
MAX6517UKN015	AELX	MAX6519UKN015	AEIE
MAX6517UKN005	AELW	MAX6519UKN005	AEID
MAX6517UKP005	AEMA	MAX6519UKP005	AEIH
MAX6517UKP015	AEMB	MAX6519UKP015	AEII
MAX6517UKP035	AEMC	MAX6519UKP035	AEIS
MAX6517UKP045	AEMD	MAX6519UKP045	AEIK
MAX6517UKP055	AEME	MAX6519UKP055	AEIL
MAX6517UKP065	AEMF	MAX6519UKP065	AEIM
MAX6517UKP075	AEDC	MAX6519UKP075	AEDG
MAX6517UKP085	AEMG	MAX6519UKP085	AEIN
MAX6517UKP095	AEMH	MAX6519UKP095	AEIO
MAX6517UKP105	AEMI	MAX6519UKP105	AEIP
MAX6517UKP115	AEMJ	MAX6519UKP115	AEIQ

## Package Information

For the latest package outline information and land patterns (footprints), go to [www.maxim-ic.com/packages](http://www.maxim-ic.com/packages). Note that a "+", "#", or "-" in the package code indicates RoHS status only. Package drawings may show a different suffix character, but the drawing pertains to the package regardless of RoHS status.

PACKAGE TYPE	PACKAGE CODE	OUTLINE NO.	LAND PATTERN NO.
5 SOT23	U5+2	<a href="#">21-0057</a>	<a href="#">90-0174</a>

# Low-Cost, 2.7V to 5.5V, Analog Temperature Sensor Switches in a SOT23

## Functional Diagram

MAX6516-MAX6519

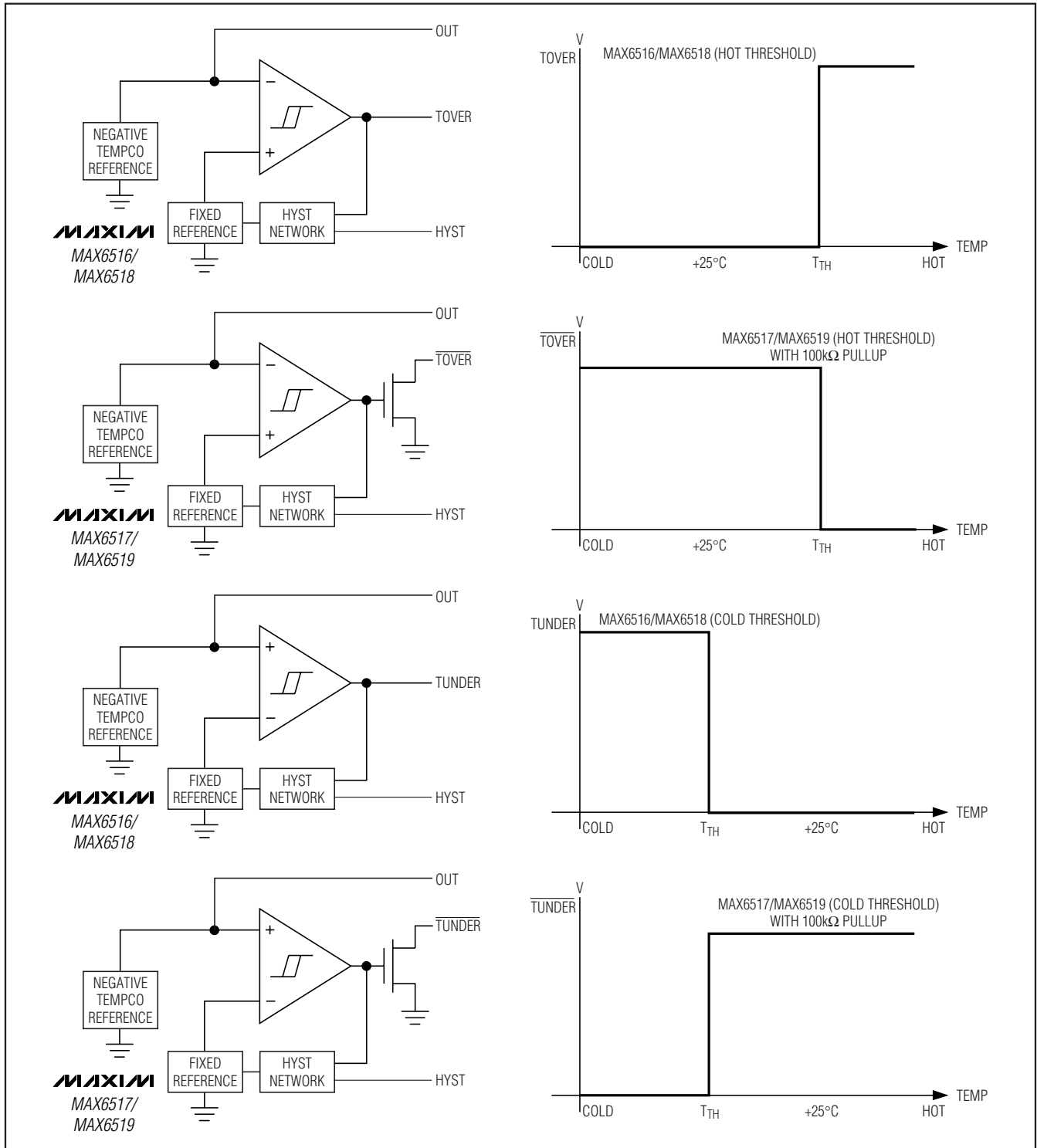

# Low-Cost, 2.7V to 5.5V, Analog Temperature Sensor Switches in a SOT23

## Revision History

REVISION NUMBER	REVISION DATE	DESCRIPTION	PAGES CHANGED
0	11/03	Initial release	—
1	2/11	Changed the leaded parts to lead(Pb)-free parts in the <i>Ordering Information</i> table; in the <i>Absolute Maximum Ratings</i> section changed the continuous power dissipation numbers (7.1mW/°C to 3.1mW/°C and 571mW to 247mW); added the <i>Package Information</i> table	1, 2, 8

Maxim cannot assume responsibility for use of any circuitry other than circuitry entirely embodied in a Maxim product. No circuit patent licenses are implied. Maxim reserves the right to change the circuitry and specifications without notice at any time.

10 \_\_\_\_\_ **Maxim Integrated Products, 120 San Gabriel Drive, Sunnyvale, CA 94086 408-737-7600**

## Looking for pricing, stock, or lifecycle information?

Click below to explore more details on WIN SOURCE:

- ⊖ [View MAX6519UKP105+T on WIN SOURCE](#)
- ⊖ [Maxim Integrated Information](#)

## Optimize Your Supply Chain with WIN SOURCE Solutions

- ✓ Global Sourcing Solution
- ✓ Obsolete Management
- ✓ Cost Control Management
- ✓ Shortage Management
- ✓ Alternative Solution
- ✓ Excess Inventory Management