



**THE DATASHEET OF
MAX6763UT+T**



MAX6754–MAX6764 Low-Power, Single/Dual-Voltage Window Detectors

General Description

The MAX6754–MAX6764 low-power window detectors monitor undervoltage/overvoltage conditions on system power supplies. These devices assert when the monitored voltage is under the undervoltage and/or over the overvoltage thresholds.

The MAX6754–MAX6759/MAX6763/MAX6764 monitor a single voltage. The MAX6760/MAX6761/MAX6762 monitor dual-voltage systems. The MAX6754/MAX6755/MAX6756 provide a single undervoltage/overvoltage output and the MAX6757–MAX6764 provide independent undervoltage and overvoltage outputs. The outputs are available in push-pull or open-drain configurations.

The MAX6754–MAX6762 offer factory-fixed voltage thresholds for monitoring system voltages from 0.9V to 5V with a selectable $\pm 5\%$, $\pm 10\%$, or $\pm 15\%$ window voltage. The MAX6763/MAX6764 allow for externally adjustable thresholds. The MAX6754–MAX6762 are available in two delay-timing options (20 μ s, typ or 100ms, min). The MAX6760/MAX6761/MAX6762 also include a latched overvoltage output function and the MAX6754–MAX6762 include a manual reset input.

This family of products is available in small SOT23 and TDFN packages, and is specified over the extended temperature range of -40°C to $+125^{\circ}\text{C}$.

Applications

- Telecommunications
- Networking
- Computers/Servers
- Data Storage
- Power Metering
- DC-DC Converter Modules
- Automotive

[Pin Configurations](#) appear towards end of data sheet.

[Ordering Information](#) appears at end of data sheet.

Benefits and Features

- Single/Dual-Supply Voltage Monitors
- Factory-Trimmed Window Threshold Options for 5V, 3.3V, 3V, 2.5V, 1.8V, 1.5V, 1.2V, and 0.9V Supplies
- Externally Adjustable Window Monitoring Options for Supplies Down to 0.5V
- Selectable Window Threshold Options ($\pm 5\%$, $\pm 10\%$, $\pm 15\%$)
- Single (Combined UV/OV) or Dual (Separate UV and OV) Outputs
- 20 μ s (typ) or 100ms (min) Timeout Period Options (MAX6754–MAX6762)
- Manual Reset Input (MAX6754–MAX6762)
- Latched Overvoltage Output Function (MAX6760/MAX6761/MAX6762)
- Immune to Short Voltage Transients
- Low 10 μ A Supply Current
- Low-Voltage Operation (Outputs Valid for VCC Down to 1V)
- -40°C to $+125^{\circ}\text{C}$ Operating Temperature Range
- Small SOT23 and TDFN Packages
- AEC-Q100 Qualified (IV Parts Only, Refer to [Ordering Information](#))

Typical Application Circuit

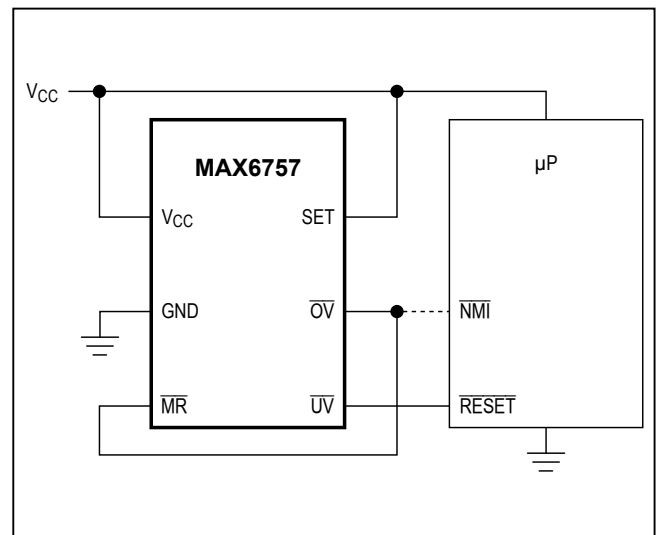

Absolute Maximum Ratings

(Voltages with respect to GND.)

V_{CC}, V_{CC2}	-0.3V to +6.5V
SET, OVLATCH, \overline{MR} , UVIN, OVIN	-0.3V to ($V_{CC} + 0.3V$)
UV, RESET, \overline{OV} (open drain)	-0.3V to +6.5V
RESET, \overline{OV} , UV, \overline{UV} , RESET (push-pull)	-0.3V to ($V_{CC} + 0.3V$)
Input/Output Current (all pins)	20mA
Continuous Power Dissipation ($T_A = +70^\circ C$)	
5-Pin SOT23-5 (derate 3.9mW/ $^\circ C$ above $T_A = +70^\circ C$) ...	312mW
6-Pin SOT23-6 (derate 8.7mW/ $^\circ C$ above $T_A = +70^\circ C$) ...	696mW
8-Pin TDFN (derate 24.4mW/ $^\circ C$ above $T_A = +70^\circ C$)	1951mW

Operating Temperature Range	-40 $^\circ C$ to +125 $^\circ C$
Junction Temperature	+150 $^\circ C$
Storage Temperature Range	-65 $^\circ C$ to +150 $^\circ C$
Lead Temperature (soldering, 10s)	+300 $^\circ C$
Soldering Temperature (reflow)	
Lead(Pb)-Free Package	+260 $^\circ C$
Containing Lead(Pb)	+240 $^\circ C$

Stresses beyond those listed under "Absolute Maximum Ratings" may cause permanent damage to the device. These are stress ratings only, and functional operation of the device at these or any other conditions beyond those indicated in the operational sections of the specifications is not implied. Exposure to absolute maximum rating conditions for extended periods may affect device reliability.

Package Information

5 SOT23

PACKAGE CODE	U5+1/U5+1A
Outline Number	21-0057
Land Pattern Number	90-0174
Thermal Resistance, Single-Layer Board:	
Junction to Ambient (θ_{JA})	324.3 $^\circ C/W$
Junction to Case (θ_{JC})	82 $^\circ C/W$
Thermal Resistance, Multi-Layer Board:	
Junction to Ambient (θ_{JA})	255.9 $^\circ C/W$
Junction to Case (θ_{JC})	81 $^\circ C/W$

6 SOT23

PACKAGE CODE	U6+1
Outline Number	21-0058
Land Pattern Number	90-0175
Thermal Resistance, Single-Layer Board:	
Junction to Ambient (θ_{JA})	N/A
Junction to Case (θ_{JC})	80 $^\circ C/W$
Thermal Resistance, Multi-Layer Board:	
Junction to Ambient (θ_{JA})	115 $^\circ C/W$
Junction to Case (θ_{JC})	80 $^\circ C/W$

8 TDFN

PACKAGE CODE	T833+2
Outline Number	21-0137
Land Pattern Number	90-0059
Thermal Resistance, Single-Layer Board:	
Junction to Ambient (θ_{JA})	54 $^\circ C/W$
Junction to Case (θ_{JC})	8 $^\circ C/W$
Thermal Resistance, Multi-Layer Board:	
Junction to Ambient (θ_{JA})	41 $^\circ C/W$
Junction to Case (θ_{JC})	8 $^\circ C/W$

Package Information (continued)

For the latest package outline information and land patterns (footprints), go to www.maximintegrated.com/packages. Note that a “+”, “#”, or “-” in the package code indicates RoHS status only. Package drawings may show a different suffix character, but the drawing pertains to the package regardless of RoHS status.

Package thermal resistances were obtained using the method described in JEDEC specification JESD51-7, using a four-layer board. For detailed information on package thermal considerations, refer to www.maximintegrated.com/thermal-tutorial.

Electrical Characteristics

($V_{CC} = 1.0V$ to $6.0V$, $V_{CC2} = 0$ to $6.0V$ (MAX6760–MAX6762), $T_A = -40^{\circ}C$ to $+125^{\circ}C$, unless otherwise noted. Typical values are at $T_A = +25^{\circ}C$.) (Note 1)

PARAMETER	SYMBOL	CONDITIONS	MIN	TYP	MAX	UNITS		
POWER REQUIREMENTS								
Operating Voltage Range	V_{CC}	(Note 2)	1.0		6.0	V		
		MAX6760TAAA/MAX6761TAAA/ MAX6762TAAA/MAX6763/MAX6764UT-T	1.4		6.0			
V_{CC} Supply Current	I_{CC}	$V_{CC} = 3.6V$, MAX6754–MAX6759, no load		13	30	μA		
		$V_{CC} = 3.6V$, MAX6763/MAX6764, no load		10	23			
		$V_{CC} = 3.6V$, $V_{CC} \geq V_{CC2}$, MAX6760/MAX6761/MAX6762, no load		13	30			
V_{CC2} Supply Current	I_{CC2}	$V_{CC2} = 1.8V$, $V_{CC} \geq V_{CC2}$, MAX6760/MAX6761/MAX6762		1	1.5	μA		
Adjustable Bias Current		V_{CC2} (MAX6760–MAX6762TA_AD_) (Note 3)	-20		+20	nA		
V_{CC} THRESHOLD								
V_{CC} Overvoltage Threshold	OV_{TH}	$T_A = -40^{\circ}C$ to $+125^{\circ}C$, rising V_{CC}	L, 5V	$V_{SET} = V_{SB}$	5.750	5.875	6.000	V
				$SET = V_{CC}$	5.500	5.625	5.750	
				$SET = GND$	5.250	5.375	5.500	
			T, 3.3V	$V_{SET} = V_{SB}$	3.795	3.878	3.960	
				$SET = V_{CC}$	3.630	3.713	3.795	
				$SET = GND$	3.465	3.548	3.630	
			R, 3.0V	$V_{SET} = V_{SB}$	3.450	3.525	3.600	
				$SET = V_{CC}$	3.300	3.375	3.450	
				$SET = GND$	3.150	3.225	3.300	
			Z, 2.5V	$V_{SET} = V_{SB}$	2.875	2.938	3.000	
				$SET = V_{CC}$	2.750	2.813	2.875	
				$SET = GND$	2.625	2.688	2.750	
			W, 1.8V	$V_{SET} = V_{SB}$	2.070	2.115	2.160	
				$SET = V_{CC}$	1.980	2.025	2.070	
				$SET = GND$	1.890	1.935	1.980	

Electrical Characteristics (continued)

($V_{CC} = 1.0V$ to $6.0V$, $V_{CC2} = 0$ to $6.0V$ (MAX6760–MAX6762), $T_A = -40^{\circ}C$ to $+125^{\circ}C$, unless otherwise noted. Typical values are at $T_A = +25^{\circ}C$.) (Note 1)

PARAMETER	SYMBOL	CONDITIONS			MIN	TYP	MAX	UNITS
V_{CC} Undervoltage Threshold	UV_{TH}	$T_A = -40^{\circ}C$ to $+125^{\circ}C$, falling V_{CC}	L, 5V	$V_{SET} = V_{SB}$	4.000	4.125	4.250	V
				$SET = V_{CC}$	4.250	4.375	4.500	
				$SET = GND$	4.500	4.625	4.750	
			T, 3.3V	$V_{SET} = V_{SB}$	2.640	2.723	2.805	
				$SET = V_{CC}$	2.805	2.888	2.970	
				$SET = GND$	2.970	3.053	3.135	
			R, 3.0V	$V_{SET} = V_{SB}$	2.400	2.475	2.550	
				$SET = V_{CC}$	2.550	2.625	2.700	
				$SET = GND$	2.700	2.775	2.850	
			Z, 2.5V	$V_{SET} = V_{SB}$	2.000	2.063	2.125	
				$SET = V_{CC}$	2.125	2.188	2.250	
				$SET = GND$	2.250	2.313	2.375	
			W, 1.8V	$V_{SET} = V_{SB}$	1.440	1.485	1.530	
				$SET = V_{CC}$	1.530	1.575	1.620	
				$SET = GND$	1.620	1.665	1.710	
V_{CC2} Overvoltage Threshold	OV_{TH2}	$T_A = -40^{\circ}C$ to $+125^{\circ}C$, rising V_{CC2}	T, 3.3V	$V_{SET} = V_{SB}$	3.795	3.878	3.960	V
				$SET = V_{CC}$	3.630	3.713	3.795	
				$SET = GND$	3.465	3.548	3.630	
			R, 3.0V	$V_{SET} = V_{SB}$	3.450	3.525	3.600	
				$SET = V_{CC}$	3.300	3.375	3.450	
				$SET = GND$	3.150	3.225	3.300	
			Z, 2.5V	$V_{SET} = V_{SB}$	2.875	2.938	3.000	
				$SET = V_{CC}$	2.750	2.813	2.875	
				$SET = GND$	2.625	2.688	2.750	
			W, 1.8V	$V_{SET} = V_{SB}$	2.070	2.115	2.160	
				$SET = V_{CC}$	1.980	2.025	2.070	
				$SET = GND$	1.890	1.935	1.980	
			I, 1.5V	$V_{SET} = V_{SB}$ (Note 2)	1.725	1.763	1.800	
				$SET = V_{CC}$ (Note 2)	1.650	1.688	1.725	
				$SET = GND$ (Note 2)	1.575	1.613	1.650	
			G, 1.2V	$V_{SET} = V_{SB}$ (Note 2)	1.380	1.410	1.440	
				$SET = V_{CC}$ (Note 2)	1.320	1.350	1.380	
				$SET = GND$ (Note 2)	1.260	1.290	1.320	
			E, 0.9V	$V_{SET} = V_{SB}$ (Note 2)	1.035	1.058	1.080	
				$SET = V_{CC}$ (Note 2)	0.990	1.013	1.035	
				$SET = GND$ (Note 2)	0.945	0.968	0.990	
ADJ	$V_{SET} = V_{SB}$	0.489	0.500	0.511				
	$SET = V_{CC}$	0.468	0.479	0.489				
	$SET = GND$	0.447	0.457	0.468				

Electrical Characteristics (continued)

($V_{CC} = 1.0V$ to $6.0V$, $V_{CC2} = 0$ to $6.0V$ (MAX6760–MAX6762), $T_A = -40^{\circ}C$ to $+125^{\circ}C$, unless otherwise noted. Typical values are at $T_A = +25^{\circ}C$.) (Note 1)

PARAMETER	SYMBOL	CONDITIONS			MIN	TYP	MAX	UNITS
V _{CC2} Undervoltage Threshold	UV _{TH2}	T _A = -40°C to +125°C, falling V _{CC2}	T, 3.3V	V _{SET} = V _{SB}	2.640	2.723	2.805	V
				SET = V _{CC}	2.805	2.888	2.970	
				SET = GND	2.970	3.053	3.135	
			R, 3.0V	V _{SET} = V _{SB}	2.400	2.475	2.550	
				SET = V _{CC}	2.550	2.625	2.700	
				SET = GND	2.700	2.775	2.850	
			Z, 2.5V	V _{SET} = V _{SB}	2.000	2.063	2.125	
				SET = V _{CC}	2.125	2.188	2.250	
				SET = GND	2.250	2.313	2.375	
			W, 1.8V	V _{SET} = V _{SB}	1.440	1.485	1.530	
				SET = V _{CC}	1.530	1.575	1.620	
				SET = GND	1.620	1.665	1.710	
			I, 1.5V	V _{SET} = V _{SB} (Note 2)	1.200	1.238	1.275	
				SET = V _{CC} (Note 2)	1.275	1.313	1.350	
				SET = GND (Note 2)	1.350	1.388	1.425	
			G, 1.2V	V _{SET} = V _{SB} (Note 2)	0.960	0.990	1.020	
				SET = V _{CC} (Note 2)	1.020	1.050	1.080	
				SET = GND (Note 2)	1.080	1.110	1.140	
			E, 0.9V	V _{SET} = V _{SB} (Note 2)	0.720	0.743	0.765	
				SET = V _{CC} (Note 2)	0.765	0.788	0.810	
				SET = GND (Note 2)	0.810	0.833	0.855	
ADJ	V _{SET} = V _{SB}	0.340	0.351	0.362				
	SET = V _{CC}	0.362	0.372	0.383				
	SET = GND	0.383	0.394	0.404				
Threshold Hysteresis	V _{HYST}	V _{CC} , V _{CC2}	0.7			%		
UNDERVOLTAGE/OVERVOLTAGE INPUTS (UVIN, OVIN) (MAX6763/MAX6764)								
UVIN, OVIN Threshold Voltage	V _{TH-IN}		0.485	0.5	0.515	V		
UVIN, OVIN Input Bias Current	I _{IN}	(Note 3)	-20		+20	nA		
UVIN, OVIN Threshold Hysteresis	V _{HYST}		0.7			%		

Electrical Characteristics (continued)

($V_{CC} = 1.0V$ to $6.0V$, $V_{CC2} = 0$ to $6.0V$ (MAX6760–MAX6762), $T_A = -40^{\circ}C$ to $+125^{\circ}C$, unless otherwise noted. Typical values are at $T_A = +25^{\circ}C$.) (Note 1)

PARAMETER	SYMBOL	CONDITIONS		MIN	TYP	MAX	UNITS
TIMING CHARACTERISTICS							
Reset and UV Timeout Period	t_{RP}	Figure 7	D0	20			μs
			D3	100	185	320	ms
V_{CC} to Reset Delay	$t_{D-RESET}$	V_{CC}/V_{CC2} falling at $10mV/\mu s$ from $UV_{TH} + 100mV$ to $UV_{TH} - 100mV$		20			μs
V_{CC} to UV Delay	t_{D-UV}	V_{CC}/V_{CC2} rising at $10mV/\mu s$ from $OV_{TH} - 100mV$ to $OV_{TH} + 100mV$		20			μs
V_{CC} to OV Delay	t_{D-OV}	V_{CC}/V_{CC2} rising at $10mV/\mu s$ from $OV_{TH} - 100mV$ to $OV_{TH} + 100mV$ (MAX6757–MAX6762 only)		20			μs
UVIN to UV Delay		(MAX6763/MAX6764)		20			μs
OVIN to OV Delay		(MAX6763/MAX6764)		20			μs
Startup Delay Time	t_{START}	D0 options only, \overline{OV} output (Note 4)		2			ms
THRESHOLD WINDOW SELECT INPUT (SET)							
Input-Voltage Low				0		0.1	V
Input Bias Voltage (Note 5)	V_{SB}	$V_{CC} = 1.4V$		0.65		0.75	V
		$V_{CC} = 3.0V$		0.81		2.19	
		$V_{CC} = 6.0V$		1.10		4.90	
Input-Voltage High				$V_{CC} - 0.1$		V_{CC}	V
Input Current	I_{SET}			-1		+1	μA
MANUAL RESET (\overline{MR})							
Input-Voltage Low						$0.23 \times V_{CC}$	V
Input-Voltage High				$0.6 \times V_{CC}$			V
Pullup Resistance to V_{CC}				26			k Ω
Minimum Pulse Width				4			μs
Transient Immunity				300			ns
Propagation Delay	t_{D-MR}	\overline{MR} falling, Figure 7		300			ns
	t_{MR_P}	\overline{MR} rising, Figure 7	D0	40			
D3			100	185	320	ms	
OVERVOLTAGE OUTPUT LATCH CONTROL INPUT (OVLATCH)							
Input-Voltage Low						$0.3 \times V_{CC}$	V
Input-Voltage High				$0.7 \times V_{CC}$			V

Electrical Characteristics (continued)

($V_{CC} = 1.0V$ to $6.0V$, $V_{CC2} = 0$ to $6.0V$ (MAX6760–MAX6762), $T_A = -40^\circ C$ to $+125^\circ C$, unless otherwise noted. Typical values are at $T_A = +25^\circ C$.) (Note 1)

PARAMETER	SYMBOL	CONDITIONS	MIN	TYP	MAX	UNITS
Input Bias Current	$I_{OVLATCH}$		-1		+1	μA
RESET, \overline{RESET}, \overline{UV}, UV, \overline{OV}						
\overline{RESET} , \overline{UV} Output Low (Open Drain or Push-Pull)	V_{OL}	Any $V_{CC} \geq 1.0V$, $I_{SINK} = 100\mu A$, output asserted			0.3	V
		Any $V_{CC} \geq 1.2V$, $I_{SINK} = 200\mu A$, output asserted			0.3	
		Any $V_{CC} \geq 1.71V$, $I_{SINK} = 1.0mA$, output asserted			0.3	
		Any $V_{CC} \geq 2.85V$, $I_{SINK} = 2.0mA$, output asserted			0.3	
		Any $V_{CC} \geq 4.75V$, $I_{SINK} = 4.0mA$, output asserted			0.3	
\overline{RESET} , \overline{UV} Output High (Push-Pull)	V_{OH}	Any $V_{CC} \geq 1.71V$, $I_{SOURCE} = 0.8mA$, output deasserted	$0.8 \times V_{CC}$			V
		Any $V_{CC} \geq 2.85V$, $I_{SOURCE} = 2.0mA$, output deasserted	$0.8 \times V_{CC}$			
		Any $V_{CC} \geq 4.75V$, $I_{SOURCE} = 4.0mA$, output deasserted	$0.8 \times V_{CC}$			
RESET, UV Output Low (Push-Pull)	V_{OL}	Any $V_{CC} \geq 1.71V$, $I_{SINK} = 1.0mA$, output deasserted			0.3	V
		Any $V_{CC} \geq 2.85V$, $I_{SINK} = 2.0mA$, output deasserted			0.3	
		Any $V_{CC} \geq 4.75V$, $I_{SINK} = 4.0mA$, output deasserted			0.3	
RESET, UV Output High (Push-Pull)	V_{OH}	Any $V_{CC} \geq 1.0V$, $I_{SOURCE} = 50\mu A$, output asserted	$0.8 \times V_{CC}$			V
		Any $V_{CC} \geq 1.2V$, $I_{SOURCE} = 100\mu A$, output asserted	$0.8 \times V_{CC}$			
		Any $V_{CC} \geq 1.71V$, $I_{SOURCE} = 0.8mA$, output asserted	$0.8 \times V_{CC}$			
		Any $V_{CC} \geq 2.85V$, $I_{SOURCE} = 2.0mA$, output asserted	$0.8 \times V_{CC}$			
		Any $V_{CC} \geq 4.75V$, $I_{SOURCE} = 4.0mA$, output asserted	$0.8 \times V_{CC}$			

Electrical Characteristics (continued)

($V_{CC} = 1.0V$ to $6.0V$, $V_{CC2} = 0$ to $6.0V$ (MAX6760–MAX6762), $T_A = -40^\circ C$ to $+125^\circ C$, unless otherwise noted. Typical values are at $T_A = +25^\circ C$.) (Note 1)

PARAMETER	SYMBOL	CONDITIONS	MIN	TYP	MAX	UNITS
\overline{OV} Output Low (Open-Drain or Push-Pull)	V_{OL}	Any $V_{CC} \geq 1.98V$, $I_{SINK} = 1.4mA$, output asserted			0.3	V
		Any $V_{CC} \geq 2.75V$, $I_{SINK} = 2.0mA$, output asserted			0.3	
		Any $V_{CC} \geq 3.63V$, $I_{SINK} = 3.0mA$, output asserted			0.3	
		Any $V_{CC} \geq 5.5V$, $I_{SINK} = 4.0mA$, output asserted			0.3	
\overline{OV} Output High (Push-Pull)	V_{OH}	Any $V_{CC} \geq 1.0V$, $I_{SOURCE} = 50\mu A$, output deasserted	$0.8 \times V_{CC}$			V
		Any $V_{CC} \geq 1.2V$, $I_{SOURCE} = 100\mu A$, output deasserted	$0.8 \times V_{CC}$			
		Any $V_{CC} \geq 1.98V$, $I_{SOURCE} = 1.4mA$, output deasserted	$0.8 \times V_{CC}$			
		Any $V_{CC} \geq 2.75V$, $I_{SOURCE} = 2.0mA$, output deasserted	$0.8 \times V_{CC}$			
		Any $V_{CC} \geq 3.63V$, $I_{SOURCE} = 3.0mA$, output deasserted	$0.8 \times V_{CC}$			
		Any $V_{CC} \geq 5.5V$, $I_{SOURCE} = 4.5mA$, output deasserted	$0.8 \times V_{CC}$			
\overline{RESET} , \overline{UV} , \overline{OV} Output Open-Drain Leakage Current	I_{LKG}	Output not asserted			1	μA

Note 1: Devices are production tested at $+25^\circ C$. Overtemperature limits are guaranteed by design.

Note 2: Voltage monitoring requires that V_{CC} must be greater than or equal to $1.4V$, but outputs remain asserted in the correct state for V_{CC} down to $1.0V$.

Note 3: Guaranteed by design.

Note 4: For D0 window detector options and \overline{OV} outputs, startup delay time is the time required for the internal reference/circuitry to reach specified accuracy after the monitor is powered up from GND.

Note 5: The input bias voltage is based off of V_{CC} . The minimum value is given by the equation $(0.1 \times V_{CC} + 0.51)V$ and the maximum value is given by $(0.9 \times V_{CC} - 0.51)V$.

Typical Operating Characteristics

($V_{CC} = 5V$, $V_{CC2} = 3.3V$, $T_A = +25^\circ C$, unless otherwise noted.)

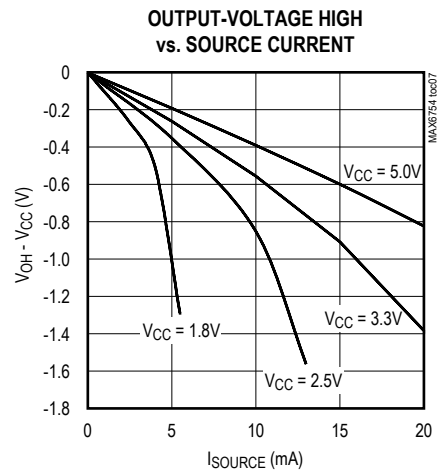
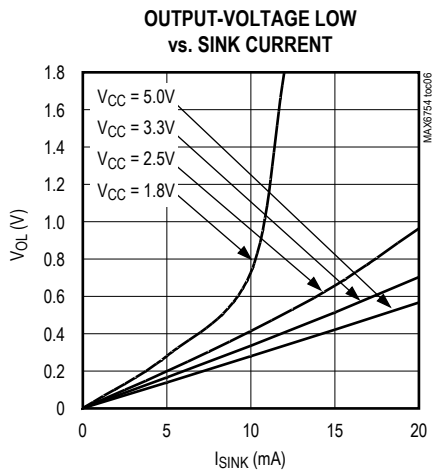
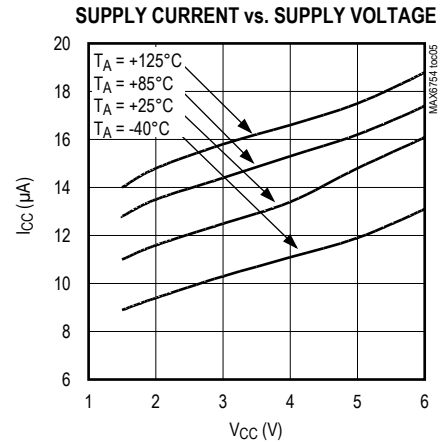
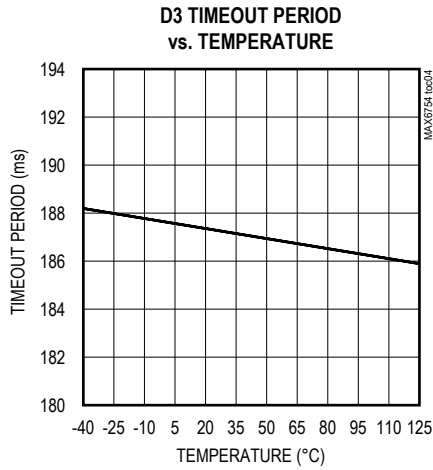
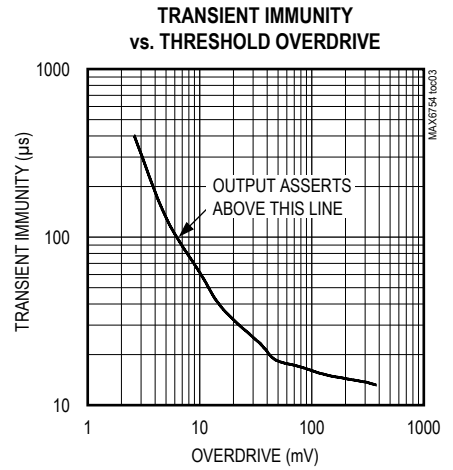
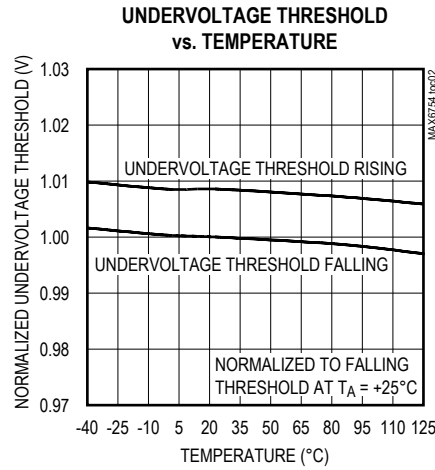
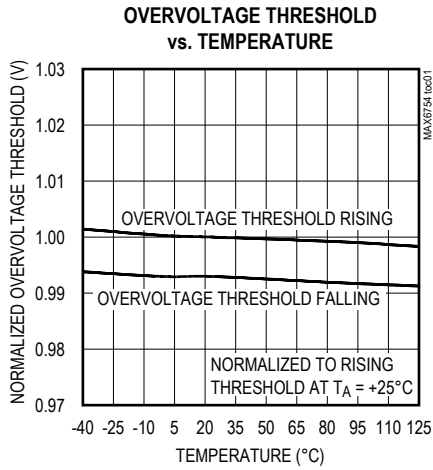

Pin Configurations

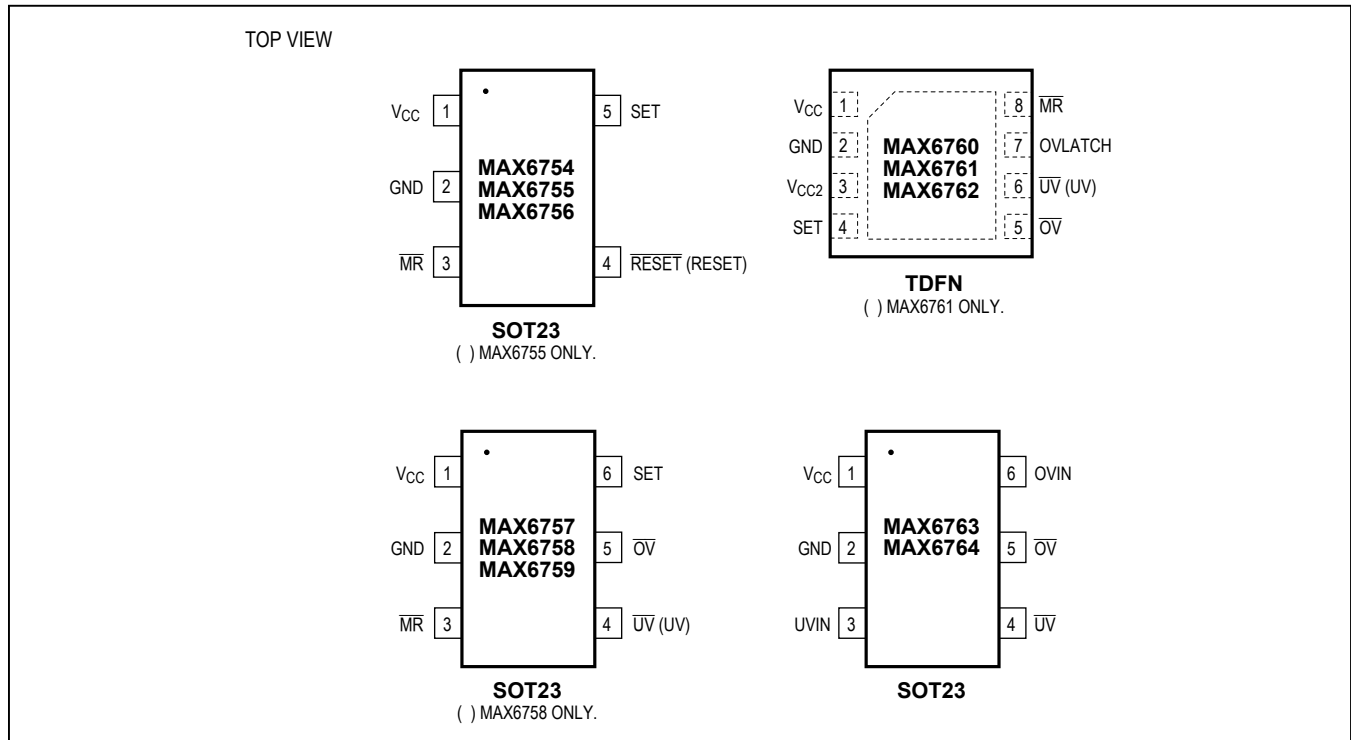

Pin Description

PIN				NAME	FUNCTION
MAX6754/ MAX6755/ MAX6756	MAX6757/ MAX6758/ MAX6759	MAX6760/ MAX6761/ MAX6762	MAX6763/ MAX6764		
1	1	1	—	V _{CC}	Power Voltage Input. V _{CC} powers the device. V _{CC} is the monitored voltage. Connect V _{CC} of the MAX6756 to an RC filter to ensure proper operation during extreme transition events. A 100Ω resistor in series with a 0.1μF bypass capacitor is sufficient for most applications. See Figure 9 for more details.
—	—	—	1	V _{CC}	Power Input. V _{CC} powers the device.
2	2	2	2	GND	Ground
3	3	8	—	MR	Active-Low Manual Reset Input. Drive MR low to assert undervoltage and reset outputs. The asserted output remains asserted for the specified propagation delay period after MR goes high. MR is internally pulled up to V _{CC} through a 26kΩ resistor.
4	—	—	—	RESET/ RESET	Reset Output. The Reset Output asserts when V _{CC} is below the selected UV _{TH} threshold or above the selected OV _{TH} threshold. Reset output deasserts after the specified timeout period after V _{CC} rises above the UV _{TH} threshold or drops below the OV _{TH} threshold. MAX6754: Active-low push-pull output (RESET). MAX6755: Active-high push-pull output (RESET). MAX6756: Active-low open-drain output (RESET).

Pin Description (continued)

PIN				NAME	FUNCTION
MAX6754/ MAX6755/ MAX6756	MAX6757/ MAX6758/ MAX6759	MAX6760/ MAX6761/ MAX6762	MAX6763/ MAX6764		
5	6	4	—	SET	Threshold Window Select Input. SET configures the undervoltage and overvoltage window range for the internal detectors. Connect SET to GND for $\pm 5\%$ window, or to V_{CC} for $\pm 10\%$ window. Bias SET to $V_{CC}/2$ for a $\pm 15\%$ window.
—	4	6	—	UV/ \overline{UV}	Undervoltage Output. UV/ \overline{UV} asserts when the monitored supply/supplies are below the UV_{TH} thresholds or \overline{MR} is low. UV/ \overline{UV} deasserts after the specified timeout period when the monitored supply/supplies rise above the UV_{TH} thresholds or for the specified propagation delay after \overline{MR} goes high. MAX6757/MAX6760: Active-low push-pull output (\overline{UV}). MAX6758/MAX6761: Active-high push-pull output (\overline{UV}). MAX6759/MAX6762: Active-low open-drain output (\overline{UV}).
—	—	3	—	V_{CC2}	V_{CC2} Voltage Input. Input for the second window voltage monitor, and device output power supply when $V_{CC2} > V_{CC}$.
—	5	5	5	\overline{OV}	Active-Low Overvoltage Output. \overline{OV} asserts low when the monitored supply/supplies are above their overvoltage threshold (OV_{TH}). \overline{OV} goes high impedance immediately when the monitored supply/supplies drop below OV_{TH} . There is no timeout delay period for the \overline{OV} output. For MAX6763/MAX6764, \overline{OV} is low when OVIN is above the internal 0.5V threshold. \overline{OV} is high when OVIN is below the internal 0.5V threshold. MAX6757–MAX6762: Active-low open-drain output. MAX6763: Active-low push-pull output. MAX6764: Active-low open-drain output.
—	—	7	—	OVLATCH	Overvoltage Output Latch Control Input. Drive OVLATCH high to latch the overvoltage output for any V_{CC} or V_{CC2} overvoltage condition. Drive OVLATCH low to clear the latch after overvoltage conditions have been removed. The latch is transparent when OVLATCH is connected to GND. OVLATCH is a high-impedance input. Use external pullup or pulldown.
—	—	—	3	UVIN	Undervoltage Input. \overline{UV} is low when UVIN is below the internal 0.5V threshold. \overline{UV} is high when UVIN is above the internal 0.5V threshold.
—	—	—	4	\overline{UV}	Undervoltage Output. \overline{UV} is low when UVIN is below the internal 0.5V threshold. \overline{UV} is high when UVIN is above the internal 0.5V threshold. There is no timeout delay period for the \overline{UV} output.
—	—	—	6	OVIN	Overvoltage Input. \overline{OV} is low when OVIN is above the internal 0.5V threshold. \overline{OV} is high when OVIN is below the internal 0.5V threshold.
—	—	—	—	EP	Exposed Pad (TDFN Only). EP is internally connected to GND. Leave EP unconnected or connect to GND.

Functional Diagrams (continued)

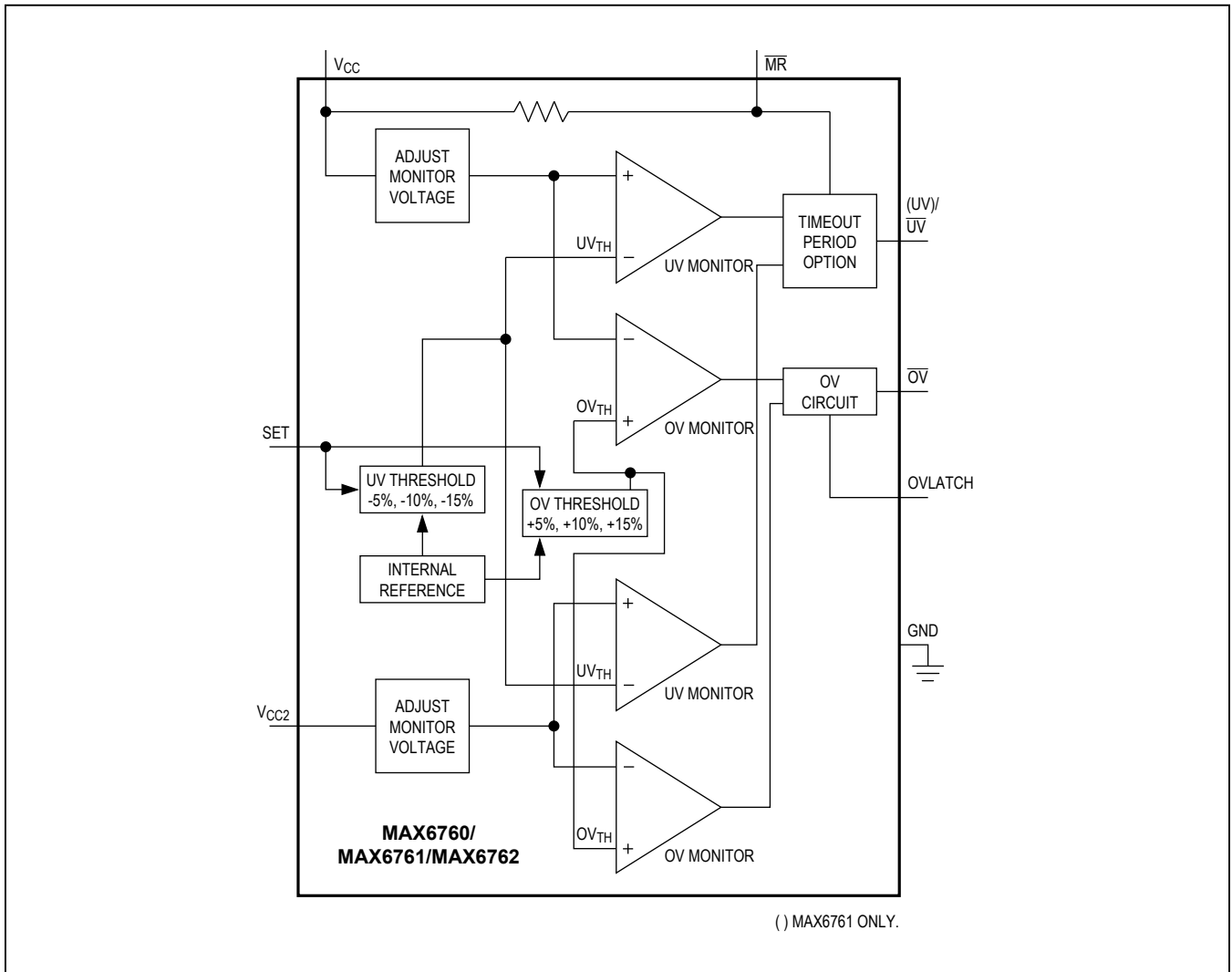

Figure 3. MAX6760/MAX6761/MAX6762 Functional Diagram

Functional Diagrams (continued)

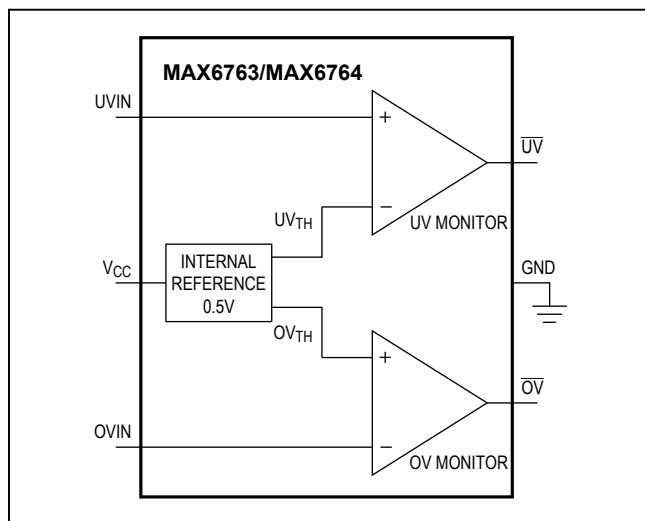

Figure 4. MAX6763/MAX6764 Functional Diagram

Detailed Description

The MAX6754–MAX6764 are low-power window voltage detectors capable of monitoring undervoltage and overvoltage conditions on system power supplies. Whenever a monitored voltage falls below its undervoltage threshold or exceeds its overvoltage threshold, these devices assert their outputs to notify the system (see [Functional Diagrams](#)).

The MAX6754/MAX6755/MAX6756 are single-voltage window detectors with internally fixed nominal voltage, externally adjustable set window, single reset undervoltage/overvoltage output, and a manual reset input.

The MAX6757/MAX6758/MAX6759 are single-voltage window detectors with internally set nominal voltage, externally adjustable set window, separate undervoltage/overvoltage outputs, and manual reset input.

The MAX6760/MAX6761/MAX6762 are dual-voltage window detectors with internally/externally set nominal voltages, externally adjustable set window, separate undervoltage/overvoltage outputs, manual reset input, and overvoltage latch functions.

The MAX6763/MAX6764 are single adjustable window detectors with separate undervoltage/overvoltage outputs.

The MAX6754–MAX6762 offer factory-fixed voltage thresholds for monitoring system voltages from 0.9V to 5V. The MAX6754–MAX6762 include a SET function to select the window voltage to $\pm 5\%$, $\pm 10\%$, or $\pm 15\%$. The MAX6763/MAX6764 allow for externally adjustable upper

and lower voltage thresholds to be set externally (down to 0.5V). The MAX6754–MAX6762 are available with two timing options (20 μ s propagation delay or 100ms minimum reset timeout).

Supply Voltages

V_{CC} is the power-supply input and the monitored voltage of the MAX6754–MAX6762. These devices feature a factory-trimmed V_{CC} and V_{CC2} divider that sets the nominal input range (see [Table 1](#) and [Table 2](#)). V_{CC} for the MAX6763/MAX6764 is the power supply of the device and not the monitored voltage. For noisy systems, bypass V_{CC} and V_{CC2} each with a 0.1 μ F capacitor to GND. Connect V_{CC} of the MAX6756 to an RC filter to ensure proper operation during extreme transition events. A 100 Ω resistor in series with a 0.1 μ F bypass capacitor is sufficient for most applications. See [Figure 9](#) for more details.

Setting the Adjustable Nominal Voltage Threshold

The MAX6760/MAX6761/MAX6762 (versions with suffixes LA, TA, RA, ZA, WA, and AA) offer adjustable nominal voltage threshold to monitor V_{CC2} . Use an external voltage-divider to set the voltage at V_{CC2} to 0.4255V. Configure SET to select a monitor window of $\pm 5\%$, $\pm 10\%$, or $\pm 15\%$ (see [Figure 5](#)). The MAX6760/MAX6761/MAX6762 suffix AA monitor only V_{CC2} and do not monitor V_{CC} .

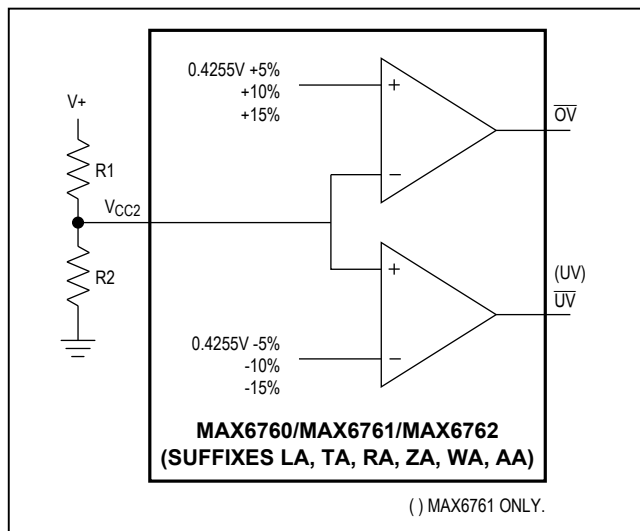

Figure 5. Setting the Threshold Voltage of V_{CC2}

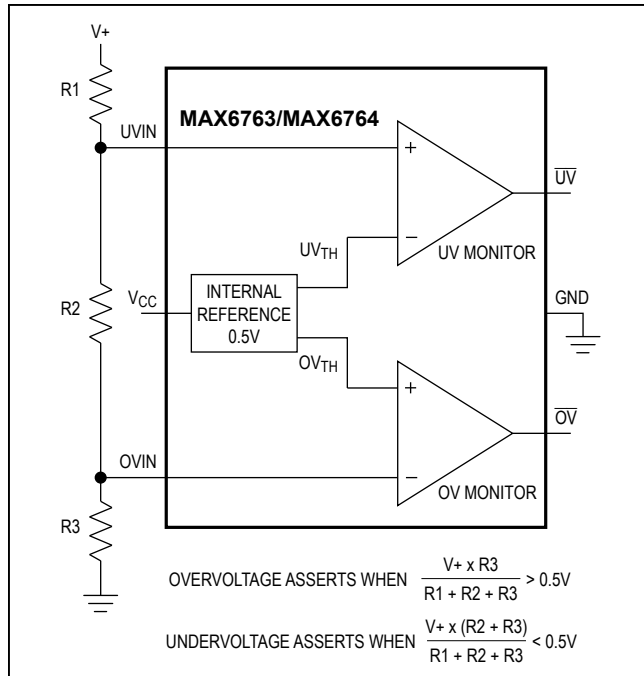

Figure 6. Setting the Undervoltage/Overvoltage Window

Choose R2 to have a resistance of up to 500kΩ. Calculate R1 by:

$$R1 = ((V+ - 0.4255V) \times R2) / 0.4255V$$

The MAX6763/MAX6764 provide inputs to a window detector allowing the programming of the threshold voltage to within VCC (see Figure 6).

Choose R1, R2, and R3 such that:

$$(V+ / (R1 + R2 + R3)) \geq 1\mu A$$

SET

The MAX6754–MAX6762 allow the setting of the window voltage range of the voltage detector. Connect SET to GND to set a ±5% window. Connect SET to VCC for a ±10% window. Bias SET to VCC / 2 for a ±15% window.

Manual Reset (\overline{MR})

The MAX6754–MAX6762 include an active-low manual reset input. Drive \overline{MR} low to assert a reset output (MAX6754/MAX6755/MAX6756) or an undervoltage output (MAX6757/MAX6758/MAX6759). The output remains asserted for the specified propagation delay time (see Figure 7a and Figure 7b) after \overline{MR} goes high. \overline{MR} is internally pulled to VCC with a 26kΩ resistor.

Overvoltage Latch Control Input (OVLATCH)

The MAX6760/MAX6761/MAX6762 provide an overvoltage latch control input (OVLATCH). Drive OVLATCH high to latch the overvoltage output for any VCC or VCC2 overvoltage condition. Drive OVLATCH low to clear the latch after overvoltage conditions have been removed. The latch is transparent when OVLATCH is connected to GND. OVLATCH is a high impedance input. Use external pullup or pulldown.

Reset, Undervoltage, and Overvoltage Outputs (\overline{RESET} , $\overline{RESE\overline{T}}$, \overline{UV} , UV, OV)

\overline{RESET} , $\overline{RESE\overline{T}}$, \overline{UV} , UV, and OV outputs assert when the monitored supply is below the selected UVTH threshold or above the selected OVTH threshold. The reset output deasserts after the specified timeout period when the monitored supply rises above the UVTH threshold or drops below the OVTH threshold. The push-pull versions are referenced to VCC.

The MAX6760/MAX6761/MAX6762 monitor both VCC and VCC2. An undervoltage/overvoltage condition on either voltage supply asserts the corresponding output. $\overline{RESE\overline{T}}$ and \overline{UV} are guaranteed to be in the correct logic state when VCC or VCC2 > 1V.

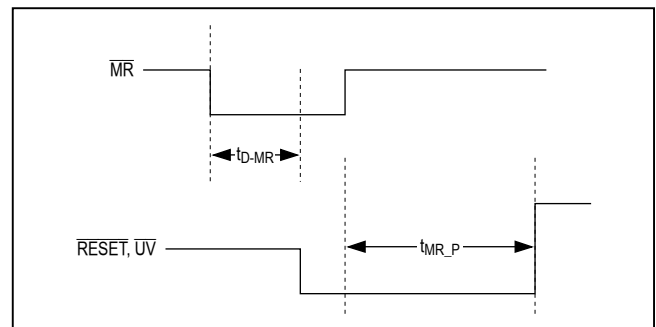

Figure 7a. Manual $\overline{RESE\overline{T}}$ /RESET Timing Diagram

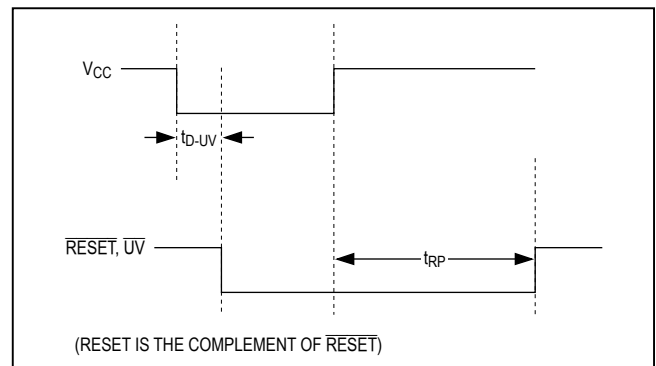

Figure 7b. VCC/ $\overline{RESE\overline{T}}$, \overline{UV} Timing Diagram

Applications Information

Microprocessor Monitoring

Figure 8 shows a microprocessor monitoring circuit. An overvoltage condition on either the core or I/O supply

turns the SCR on, blowing the fuse to disconnect the circuit from the power source. An optional capacitor (C1) on the gate of the SCR provides additional transient immunity against nuisance trips.

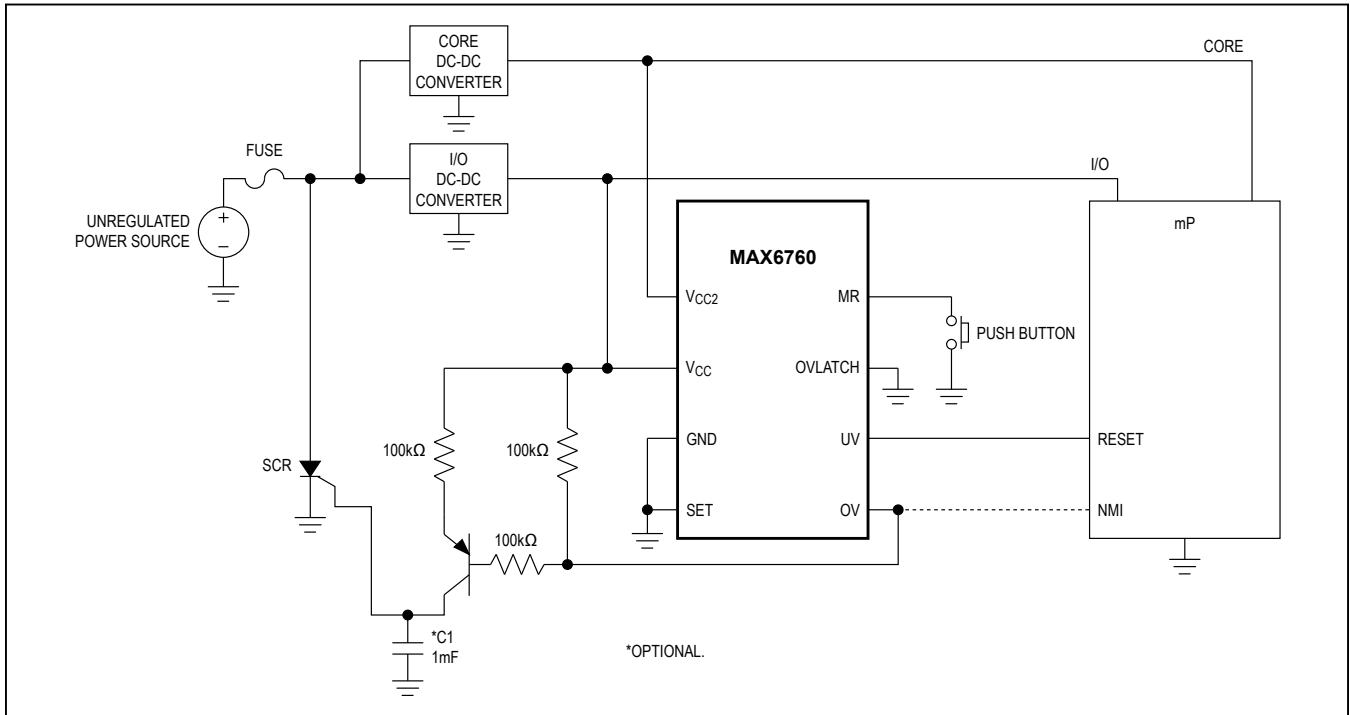

Figure 8. Microprocessor Monitoring

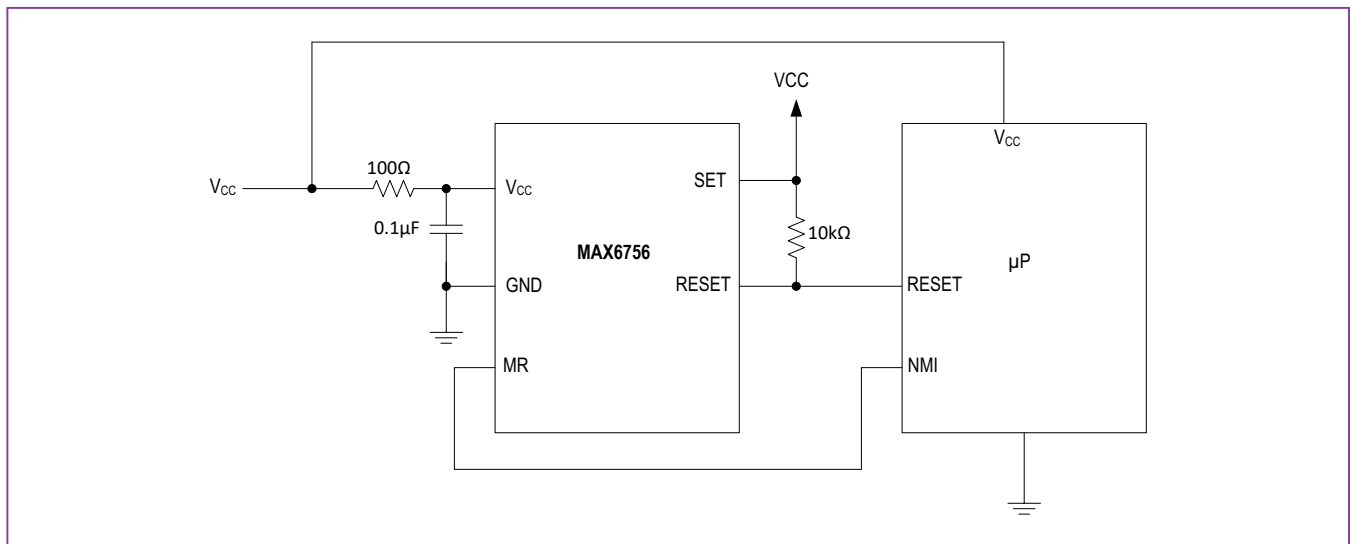

Figure 9. MAX6756 Input Filter Connection

Table 1. Window Threshold Voltage Suffix Guide Single Fixed V_{CC} (MAX6754—MAX6759)

PART NO. SUFFIX	V _{CC} NOMINAL SYSTEM VOLTAGE (V)
L	5.0
T	3.3
R	3.0
Z	2.5
W	1.8

Table 2. Window Threshold Voltage Suffix Guide Dual Fixed/Adjustable (MAX6760/MAX6761/MAX6762)

PART NO. SUFFIX	V _{CC} NOMINAL SYSTEM VOLTAGE (V)	V _{CC2} NOMINAL SYSTEM VOLTAGE (V)
LT	5	3.3
LR	5	3.0
LA	5	ADJ*
TZ	3.3	2.5
TW	3.3	1.8
TI	3.3	1.5
TG	3.3	1.2
TE	3.3	0.9
TA	3.3	ADJ*
RZ	3.0	2.5
RW	3.0	1.8
RI	3.0	1.5
RG	3.0	1.2
RE	3.0	0.9
RA	3.0	ADJ*
ZW	2.5	1.8
ZI	2.5	1.5
ZG	2.5	1.2
ZE	2.5	0.9
ZA	2.5	ADJ*
WI	1.8	1.5
WG	1.8	1.2
WE	1.8	0.9
WA	1.8	ADJ*
AA	—	ADJ*

*See the [Setting the Adjustable Nominal Voltage Threshold](#) section.

Table 3. Timeout Period Suffix Guide

TIMEOUT PERIOD SUFFIX	ACTIVE TIMEOUT PERIOD		
	MIN (ms)	Typ (ms)	MAX (ms)
D0	—	0.02	—
D3	100	185	320

Standard Versions Table

PART	PART
MAX6754 UKLD0	MAX6759 UTLDO
MAX6754UKLD3	MAX6759UTLD3
MAX6754UKTD0	MAX6759UTTDO
MAX6754UKTD3	MAX6759UTTD3
MAX6754UKZD0	MAX6759UTZD0
MAX6754UKZD3	MAX6759UTZD3
MAX6754UKWD0	MAX6759UTWDO
MAX6754UKWD3	MAX6759UTWD3
MAX6755 UKLD0	MAX6760 TALTD3
MAX6755UKLD3	MAX6760TALAD3
MAX6755UKTD0	MAX6760TATZD3
MAX6755UKTD3	MAX6760TATWD3
MAX6755UKZD0	MAX6760TATAD3
MAX6755UKZD3	MAX6760TARAD3
MAX6755UKWD0	MAX6760TAZWD3
MAX6755UKWD3	MAX6760TAZAD3
MAX6756 UKLD0	MAX6760TAWED3
MAX6756UKLD3	MAX6760TAWAD3
MAX6756UKTD0	MAX6761 TALTD3
MAX6756UKTD3	MAX6761TALAD3
MAX6756UKZD0	MAX6761TATZD3
MAX6756UKZD3	MAX6761TATWD3
MAX6756UKWD0	MAX6761TATAD3
MAX6756UKWD3	MAX6761TARAD3
MAX6757 UTTD0	MAX6761TAZWD3
MAX6757UTTD3	MAX6761TAZAD3
MAX6757UTLDO	MAX6761TAWED3
MAX6757UTLD3	MAX6761TAWAD3
MAX6757UTZD0	MAX6762 TALTD3
MAX6757UTZD3	MAX6762TALAD3
MAX6757UTWDO	MAX6762TATZD3
MAX6757UTWD3	MAX6762TATWD3
MAX6758 UTLDO	MAX6762TATAD3
MAX6758UTLD3	MAX6762TARAD3
MAX6758UTTD0	MAX6762TAZWD3
MAX6758UTTD3	MAX6762TAZAD3
MAX6758UTZD0	MAX6762TAWED3
MAX6758UTZD3	MAX6762TAWAD3
MAX6758UTWDO	MAX6763 UT
MAX6758UTWD3	MAX6764 UT

Selector Guide

	PUSH-PULL $\overline{\text{RESET}}$	PUSH-PULL RESET	OPEN-DRAIN $\overline{\text{RESET}}$	PUSH-PULL $\overline{\text{UV}}$	PUSH-PULL UV	OPEN-DRAIN $\overline{\text{UV}}$	PUSH-PULL $\overline{\text{OV}}$	OPEN-DRAIN $\overline{\text{OV}}$
MAX6754	X	—	—	—	—	—	—	—
MAX6755	—	X	—	—	—	—	—	—
MAX6756	—	—	X	—	—	—	—	—
MAX6757	—	—	—	X	—	—	—	X
MAX6758	—	—	—	—	X	—	—	X
MAX6759	—	—	—	—	—	X	—	X
MAX6760	—	—	—	X	—	—	—	X
MAX6761	—	—	—	—	X	—	—	X
MAX6762	—	—	—	—	—	X	—	X
MAX6763	—	—	—	X	—	—	X	—
MAX6764	—	—	—	—	—	X	—	X

Ordering Information

PART	TEMP RANGE	PIN-PACKAGE
MAX6754UK_D_-T	-40°C to +125°C	5 SOT23-5
MAX6755UK_D_-T	-40°C to +125°C	5 SOT23-5
MAX6756UK_D_-T	-40°C to +125°C	5 SOT23-5
MAX6756UK_D_/V+T	-40°C to +125°C	5 SOT23-5
MAX6757UT_D_-T	-40°C to +125°C	6 SOT23-6
MAX6758UT_D_-T	-40°C to +125°C	6 SOT23-6
MAX6759UT_D_/V-T	-40°C to +125°C	6 SOT23-6
MAX6760TA__D_-T	-40°C to +125°C	8 TDFN-EP
MAX6761TA__D_-T	-40°C to +125°C	8 TDFN-EP
MAX6762TA__D_-T	-40°C to +125°C	8 TDFN-EP
MAX6763UT-T	-40°C to +125°C	6 SOT23-6
MAX6764UT-T	-40°C to +125°C	6 SOT23-6

Devices are available in both leaded and lead(Pb)-free packaging. Specify lead-free by replacing “-T” with “+T” when ordering.

/V denotes an automotive qualified part.

Insert the threshold level suffixes for V_{CC} and V_{CC2} (see [Table 1](#) and [Table 2](#)) after UK, UT, or TA. For the MAX6754–MAX6759, insert only the V_{CC} threshold suffix after the UK or UT. Insert the reset timeout delay (see [Table 3](#)) after D to complete the part number. For example, the MAX6760TALTD3-T provides a V_{CC} threshold of 5V, a V_{CC2} threshold of 3.3V, and a 100ms minimum reset timeout period. Sample stock is generally held on standard versions only (see the [Standard Versions Table](#)).

Standard versions have an order increment requirement of 2500 pieces. Nonstandard versions have an order increment requirement of 10,000 pieces. Contact factory for availability.

Chip Information

PROCESS: BiCMOS

Revision History

REVISION NUMBER	REVISION DATE	DESCRIPTION	PAGES CHANGED
4	1/11	Added <i>I_V</i> to the MAX6759 <i>Ordering Information</i> and added soldering temperature in the <i>Absolute Maximum Rating</i> section	2, 16
5	10/15	Adding <i>I_V</i> part number of MAX6756 to data sheet	1, 16–18
6	11/15	Updated package code for 5 SOT23 in <i>Ordering Information</i> section	19
7	3/16	Re-added <i>Standard Versions</i> table	17–18
8	6/16	Removed top mark information from <i>Standard Versions</i> table	17–18
9	3/17	Moved <i>Ordering Information</i> and <i>Selector Guide</i> to end of data sheet and <i>Pin Configurations</i> to before <i>Pin Description</i> table; updated <i>Pin Description</i> (row 1), <i>Supply Voltages</i> section, and added Figure 9	1, 9, 13, 16, 17
10	11/17	Added AEC statement to <i>Benefits and Features</i> section	1
11	3/19	Updated <i>Package Information</i>	2, 17

For pricing, delivery, and ordering information, please visit Maxim Integrated's online storefront at <https://www.maximintegrated.com/en/storefront/storefront.html>.

Maxim Integrated cannot assume responsibility for use of any circuitry other than circuitry entirely embodied in a Maxim Integrated product. No circuit patent licenses are implied. Maxim Integrated reserves the right to change the circuitry and specifications without notice at any time. The parametric values (min and max limits) shown in the Electrical Characteristics table are guaranteed. Other parametric values quoted in this data sheet are provided for guidance.

Looking for pricing, stock, or lifecycle information?

Click below to explore more details on WIN SOURCE:

 [View MAX6763UT+T on WIN SOURCE](#)

 [Maxim Integrated Information](#)

Optimize Your Supply Chain with WIN SOURCE Solutions

-  Global Sourcing Solution
-  Obsolete Management
-  Cost Control Management
-  Shortage Management
-  Alternative Solution
-  Excess Inventory Management