



**THE DATASHEET OF
MAX6958AAEE+**





2-Wire Interfaced, 3V to 5.5V, 4-Digit, 9-Segment LED Display Drivers with Keyscan

General Description

The MAX6958/MAX6959 compact multiplexed common-cathode display drivers interface microprocessors to seven-segment numeric LED digits, or discrete LEDs through an SMBus™- and I²C-compatible 2-wire serial interface. The 2-wire serial interface uses fixed 0.8V/2.1V logic thresholds for compatibility with 2.5V and 3.3V systems when the display driver is powered from a 5V supply.

The MAX6958/MAX6959 drive up to four 7-segment digits, with decimal points, plus four discrete LEDs, or four 7-segment digits and eight discrete LEDs if the digits' decimal points are not used, or up to 36 discrete LEDs. The MAX6959 also includes two input ports, one or both of which may be configured as a key-switch reader, which automatically scans and debounces a matrix of up to eight switches. Key-switch status is obtained by polling internal status registers or by configuring the MAX6959 interrupt output.

Other on-chip features include a hexadecimal font for seven-segment displays, multiplex scan circuitry, anode and cathode drivers, and static RAM that stores each digit. The peak segment current for the display digits is set internally to 23mA. Display intensity is adjusted using a 64-step internal digital brightness control. The MAX6958/MAX6959 include a low-power shutdown mode, a scan-limit register that allows the user to display from one to four digits, and a test mode, which forces all LEDs on. The LED drivers are slew-rate-limited to reduce EMI.

The MAX6958/MAX6959 are available in 16-pin PDIP and QSOP packages and are fully specified over the -40°C to +125°C automotive temperature range.

Applications

Set-Top Boxes	Audio/Video Equipment
Panel Meters	Vending Machines
White Goods	Industrial Controls

Pin Configuration, Functional Diagram, and Typical Application Circuit appear at end of data sheet.

SMBus is a trademark of Intel Corp.



Features

- ◆ 400kbps 2-Wire Serial Interface
- ◆ 3V to 5.5V Operation
- ◆ Drive 4 Digits plus 4 or 8 Discrete LEDs
- ◆ Drive Common-Cathode LED Digits
- ◆ 23mA Constant-Current LED Segment Drive
- ◆ Hexadecimal Decode/No-Decode Digit Selection
- ◆ 64-Step Digital Brightness Control
- ◆ Slew-Rate-Limited Segment Drivers Reduced EMI
- ◆ Debounces Up to Eight Switches with n-Key Rollover (MAX6959 Only)
- ◆ IRQ Output When a Key Input Is Debounced (MAX6959 Only)
- ◆ 20µA Low-Power Shutdown (Data Retained)
- ◆ Automotive Temperature Range (-40°C to +125°C)
- ◆ Compact 16-Pin PDIP and QSOP Packages

Ordering Information

PART	TEMP RANGE	SLAVE ADDRESS	PIN-PACKAGE	PKG CODE
MAX6958AAEE	-40°C to +125°C	0111000	16 QSOP	E16-1
MAX6958AAPE	-40°C to +125°C	0111000	16 DIP	P16-1

Ordering Information continued at end of data sheet.

Typical Operating Circuit

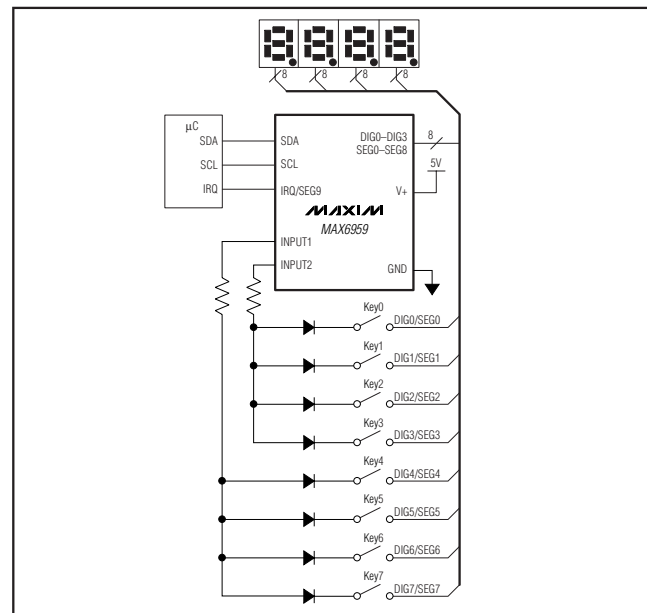

MAX6958/MAX6959

2-Wire Interfaced, 3V to 5.5V, 4-Digit, 9-Segment LED Display Drivers with Keyscan

ABSOLUTE MAXIMUM RATINGS

(Voltage with respect to GND.)

V+, SCL, SDA	-0.3V to +6V
All Other Pins	-0.3V to (V+ + 0.3V)
Current	
DIG0/SEG0–DIG3/SEG3 Sink Current	275mA
DIG0/SEG0–SEG9 Source Current	30mA
SCL, SDA, INPUT1, INPUT2	20mA

Continuous Power Dissipation ($T_A = +70^\circ\text{C}$)

16-Pin QSOP (derate at 8.34mW/°C above +70°C).....	667mW
16-Pin DIP (derate at 10.5mW/°C above +70°C).....	842mW
Operating Temperature Range	
MAX695_ (T_{MIN} to T_{MAX})	-40°C to +125°C
Junction Temperature	+150°C
Storage Temperature Range	-65°C to +150°C
Lead Temperature (soldering, 10s)	+300°C

Stresses beyond those listed under "Absolute Maximum Ratings" may cause permanent damage to the device. These are stress ratings only, and functional operation of the device at these or any other conditions beyond those indicated in the operational sections of the specifications is not implied. Exposure to absolute maximum rating conditions for extended periods may affect device reliability.

DC ELECTRICAL CHARACTERISTICS

($V_+ = 3\text{V}$ to 5.5V , $T_A = T_{\text{MIN}}$ to T_{MAX} , unless otherwise noted. Typical values are at $V_+ = 5\text{V}$, $T_A = +25^\circ\text{C}$.) (Note 1)

PARAMETER	SYMBOL	CONDITIONS	MIN	TYP	MAX	UNITS	
Operating Supply Voltage	V_+		3		5.5	V	
Shutdown Supply Current	I_{SHDN}	Shutdown mode, all digital inputs at V_+	$T_A = +25^\circ\text{C}$	20	50	μA	
			$T_A = T_{\text{MIN}}$ to $+85^\circ\text{C}$		125		
Operating Supply Current	I_+	Intensity set to full, no display load connected, INPUT1 and INPUT2 open circuit	$T_A = +25^\circ\text{C}$	5.9	6.7	mA	
			$T_A = T_{\text{MIN}}$ to T_{MAX}		7.5		
Display Scan Rate	f_{SCAN}	4 digits scanned	$T_A = T_{\text{MIN}}$ to T_{MAX}	510	780	1050	Hz
Keyscan Debounce Time	t_{DEBOUNCE}		$T_A = T_{\text{MIN}}$ to T_{MAX}	30.3	41	63	ms
Segment Drive Source Current	I_{SEG}	$V_{\text{LED}} = 2.4\text{V}$, $V_+ = 4.5\text{V}$ to 5.5V	$T_A = +25^\circ\text{C}$	-19	-23	-29	mA
			$T_A = T_{\text{MIN}}$ to T_{MAX}	-18		-30	
			$T_A = +25^\circ\text{C}$	-16		-29.5	
		$V_{\text{LED}} = 2\text{V}$, $V_+ = 3\text{V}$ to 5.5V	$T_A = T_{\text{MIN}}$ to T_{MAX}	-15.5		-30.5	
Segment Current Slew Rate	$\Delta I_{\text{SEG}}/\Delta t$			11		$\text{mA}/\mu\text{s}$	
Segment Drive Current Matching	ΔI_{SEG}			4		%	
LOGIC INPUTS AND OUTPUTS							
Input Leakage Current SCL and SDA	$I_{\text{IH}}, I_{\text{IL}}$		-1		+1	μA	
Logic High Input Voltage SCL, SDA	V_{IH}		2.1			V	
Logic Low Input Voltage SCL, SDA	V_{IL}				0.8	V	
Input Leakage Current INPUT1, INPUT2	$I_{\text{INH}}, I_{\text{INL}}$	INPUT_ = V_+	-1		+1	μA	
Logic High Input Voltage INPUT1, INPUT2	V_{INH}		$0.7 \times V_+$			V	
Logic Low Input Voltage INPUT1, INPUT2	V_{INL}				$0.3 \times V_+$	V	

2-Wire Interfaced, 3V to 5.5V, 4-Digit, 9-Segment LED Display Drivers with Keyscan

MAX6958/MAX6959

DC ELECTRICAL CHARACTERISTICS (continued)

(V+ = 3V to 5.5V, T_A = T_{MIN} to T_{MAX}, unless otherwise noted. Typical values are at V+ = 5V, T_A = +25°C.) (Note 1)

PARAMETER	SYMBOL	CONDITIONS	MIN	TYP	MAX	UNITS
Pullup to V+ INPUT1, INPUT2	I _{PULLUP}			26.5		μA
IRQ/SEG9, SDA Output Low Voltage	V _{OLBK}	I _{SINK} = 6mA, T _A = -40°C to +85°C			0.4	V
		I _{SINK} = 4mA, T _A = T _{MIN} to T _{MAX}			0.4	
SDA Output Low Voltage	V _{OL(SDA)}	I _{SINK} = 6mA			0.4	V

TIMING CHARACTERISTICS

(V+ = 3V to 5.5V, T_A = T_{MIN} to T_{MAX}, Figure 1, unless otherwise noted.) (Note 1)

PARAMETER	SYMBOL	CONDITIONS	MIN	TYP	MAX	UNITS
Serial Clock Frequency	f _{SCL}				400	kHz
Bus Free Time Between a STOP and a START Condition	t _{BUF}		1.3			μs
Hold Time (Repeated) START Condition	t _{HD, STA}		0.6			μs
Repeated START Setup Time	t _{SU, STA}		0.6			μs
STOP Condition Setup Time	t _{SU, STO}		0.6			μs
Data Hold Time	t _{HD, DAT}	(Note 3)			0.9	μs
Data Setup Time	t _{SU, DAT}		100			ns
SCL Clock Low Period	t _{LOW}		1.3			μs
SCL Clock High Period	t _{HIGH}		0.6			μs
Rise Time of Both SDA and SCL Signals, Receiving	t _R	(Notes 2, 4)		20 + 0.1C _B	300	ns
Fall Time of Both SDA and SCL Signals, Receiving	t _F	(Notes 2, 4)		20 + 0.1C _B	300	ns
Fall Time of SDA Transmitting	t _F	(Notes 2, 5)		20 + 0.1C _B	250	ns
Pulse Width of Spike Suppressed	t _{SP}	(Note 6)		50		ns
Capacitive Load for Each Bus Line	C _B			400		pF

Note 1: All parameters tested at T_A = +25°C. Specifications over temperature are guaranteed by design.

Note 2: Guaranteed by design.

Note 3: A master device must provide a hold time of at least 300ns for the SDA signal (referred to V_{IL} of the SCL signal) in order to bridge the undefined region of SCL's falling edge.

Note 4: C_B = total capacitance of one bus line in pF. t_R and t_F measured between 0.3V+ and 0.7V+.

Note 5: I_{SINK} ≤ 6mA. C_B = total capacitance of one bus line in pF. t_R and t_F measured between 0.3V+ and 0.7V+.

Note 6: Input filters on the SDA and SCL inputs suppress noise spikes less than 50ns.

2-Wire Interfaced, 3V to 5.5V, 4-Digit, 9-Segment LED Display Drivers with Keyscan

Typical Operating Characteristics

(V+ = 5V, LED forward voltage = 2.4V, T_A = +25°C, unless otherwise noted.)

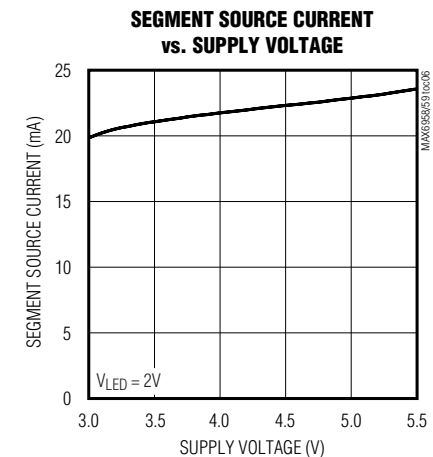
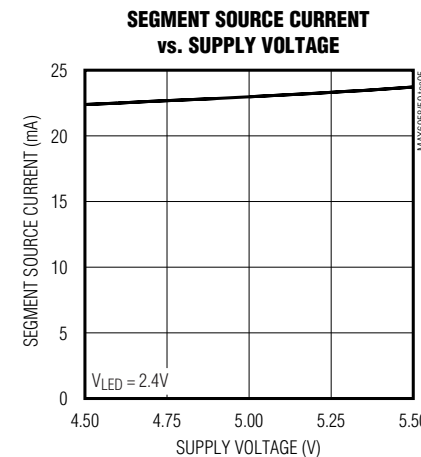
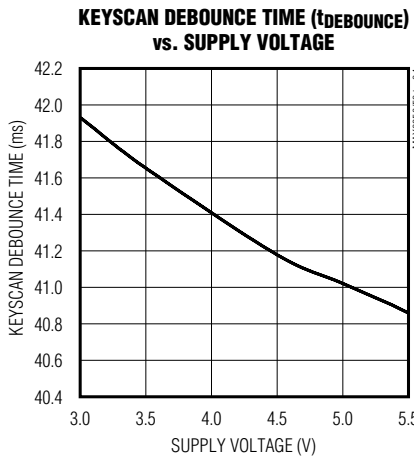
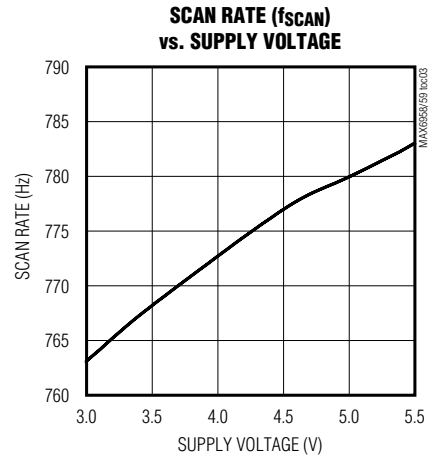
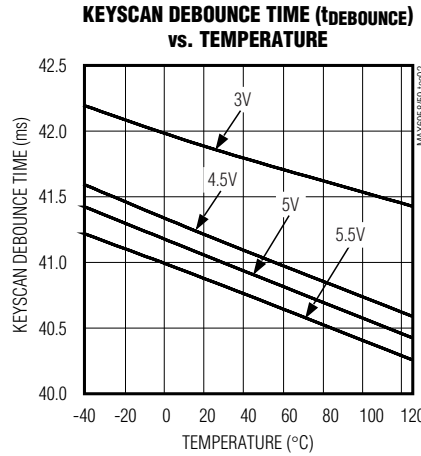
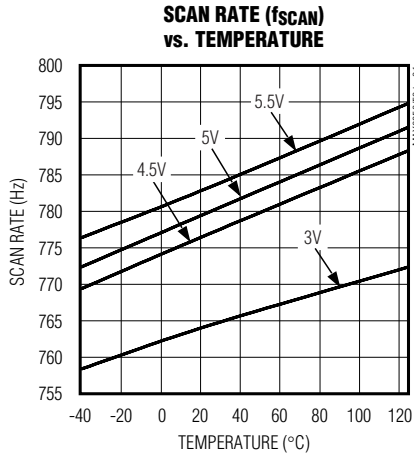

WAVEFORM AT DIG0/SEGO, FULL INTENSITY

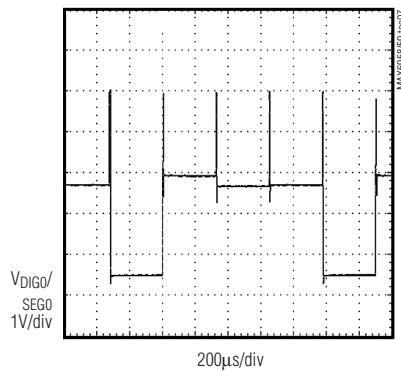

INPUT PULLUP CURRENT vs. TEMPERATURE

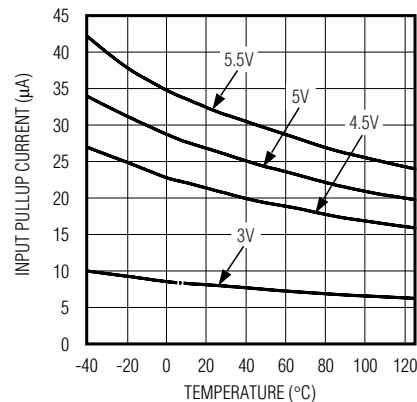

2-Wire Interfaced, 3V to 5.5V, 4-Digit, 9-Segment LED Display Drivers with Keyscan

MAX6958/MAX6959

Pin Description

PIN		NAME	FUNCTION
MAX6958	MAX6959		
1	1	SDA	Serial Data I/O
2	2	SCL	Serial Clock Input
3	—	SEG9	Segment Output. Segment driver sourcing current to a display anode.
—	3	IRQ/SEG9	Interrupt or Segment Output. May be segment driver sourcing current to a display anode, or open-drain interrupt output, or open-drain logic output.
4–7, 11–15	4–7, 11–15	DIGX, SEGX	Digit and Segment Drivers. Digit X outputs sink current from the display common cathode when acting as digit drivers. Segment X drivers source current to the display anodes. Segment/digit drivers are high impedance when turned off.
8	8	GND	Ground
9, 10	—	N.C.	No Connect. Connect to V+ or leave open.
—	9	INPUT1	General-Purpose Input Port 1 with Internal Pullup. May be configured as general-purpose logic input or keyscan input. Connect to V+ or leave open if unused.
—	10	INPUT2	General-Purpose Input Port 2 with Internal Pullup. May be configured as general-purpose logic input or keyscan input. Connect to V+ or leave open if unused.
16	16	V+	Positive Supply Voltage

Detailed Description

The MAX6958/MAX6959 serially interfaced display drivers drive up to: four 7-segment digits plus four discrete LEDs if the decimal points are used, or four 7-segment digits plus eight discrete LEDs if the decimal points are not used, or 36 discrete LEDs. Table 1 lists the display connection scheme.

The MAX6958/MAX6959 include the hexadecimal font map for seven-segment displays. The seven-segment LED digits can be controlled directly or programmed to use the hexadecimal font. Direct segment control allows the MAX6958/MAX6959 to drive bar graphs and discrete LED indicators.

The MAX6958/MAX6959 use a multiplexing scheme that minimizes the connections between the driver and LED display. The MAX6958/MAX6959 can drive monochrome and bicolor single-digit type displays, and monochrome dual-digit displays. Dual-digit displays internally wire together the equivalent segments for each digit, requiring only eight segment pins instead of 16. The

MAX6958/MAX6959 can also drive multidigit LED displays that have the segments individually pinned for each digit.

To connect four single-digit displays to the MAX6958/MAX6959, connect cathode outputs DIG0/SEG0–DIG3/SEG3 to the cathodes of the four display digits as shown in Table 1 (CC0–CC3). Drive eight additional LEDs with SEG0 to SEG7. Four of the eight LEDs can be the decimal point (DP) segments of the four displays, and the other four can be discrete LED indicators.

To connect two dual-digit displays to the MAX6958/MAX6959, connect cathode outputs DIG0/SEG0 and DIG1/SEG1 to the cathodes of the first dual digit. Connect DIG2/SEG2 and DIG3/SEG3 to the cathodes of the second dual digit. SEG0 to SEG3 can only drive discrete LEDs, not digit DP segments. SEG4 to SEG7 can drive the DP segments if required. Bicolor single-digit displays are connected and treated as dual-digit displays, each digit being one of the two colors.

Table 1. Standard Driver Connection to LED Displays

	DIG0/SEG0	DIG1/SEG1	DIG2/SEG2	DIG3/SEG3	SEG 4	SEG 5	SEG 6	SEG 7	SEG 8	SEG 9/IRQ
LED Digit 0	CC0	SEG 0	SEG g	SEG f	SEG e	SEG d	SEG c	SEG b	SEG a	SEG 4
LED Digit 1	SEG 1	CC1	SEG g	SEG f	SEG e	SEG d	SEG c	SEG b	SEG a	SEG 5
LED Digit 2	SEG g	SEG f	CC2	SEG 2	SEG e	SEG d	SEG c	SEG b	SEG a	SEG 6
LED Digit 3	SEG g	SEG f	SEG 3	CC3	SEG e	SEG d	SEG c	SEG b	SEG a	SEG 7

2-Wire Interfaced, 3V to 5.5V, 4-Digit, 9-Segment LED Display Drivers with Keyscan

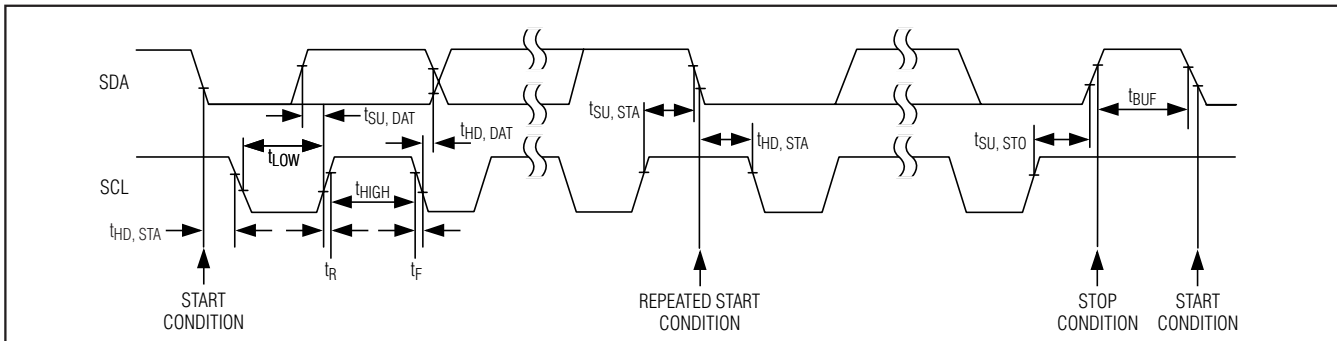

Figure 1. 2-Wire Serial Interface Timing Details

Differences Between MAX6958 and MAX6959

The MAX6958/MAX6959 have the same LED drive capability, four common-cathode digits of nine segments per digit. The MAX6959 additionally contains two logic input ports, INPUT1 and INPUT2. Each input port can be individually configured as either a general-purpose input port that is read through the serial interface, or as a keyscan input. In keyscan mode, the input is used to read and automatically debounce four key switches. A maximum of eight key switches can be read if both INPUT1 and INPUT2 are assigned to keyscanning.

The MAX6958's SEG9 output is preconfigured as the 9th LED segment output. The IRQ/SEG9 output on the MAX6959 can be configured as either an open-drain logic output or the 9th segment output. This logic output serves as either a general-purpose logic output, set through the serial interface, or an interrupt (IRQ) output that alerts a microcontroller of debounced key-switch events. Key-switch status can also be obtained by polling the internal status registers at any time.

Use the Option bit in the configuration register to detect whether a MAX6958 or MAX6959 is present. The option bit allows host software to establish whether a high-end front panel (using the MAX6959 for keyscan support) or a low-end panel (using a MAX6958 and no key switches) is fitted to a product.

Serial Interface

Serial Addressing

The MAX6958/MAX6959 operate as a slave that sends and receives data through a 2-wire interface. The interface uses a serial data line (SDA) and a serial clock line (SCL) to achieve bidirectional communication between master(s) and slave(s). A master, typically a microcontroller, initiates all data transfers to and from the MAX6958/MAX6959, and generates the SCL clock that synchronizes the data transfer (Figure 1).

The MAX6958/MAX6959 SDA line operates as both an input and an open-drain output. A pullup resistor, typically $4.7k\Omega$, is required on the SDA bus. The MAX6958/MAX6959 SCL line operates only as an input. A pullup resistor, typically $4.7k\Omega$, is required on the SCL bus if there are multiple masters on the 2-wire interface, or if the master in a single-master system has an open-drain SCL output.

Each transmission consists of a START condition (Figure 2) sent by a master, followed by the MAX6958/MAX6959 7-bit slave address plus R/W bit (Figure 3), 1 or more data bytes, and finally a STOP condition (Figure 2).

Start and Stop Conditions

Both SCL and SDA remain high when the interface is not busy. A master signals the beginning of a transmission with a START (S) condition by transitioning SDA from high to low while SCL is high. When the master has finished communicating with the slave, it issues a STOP (P) condition by transitioning the SDA from low to high while SCL is high. The bus is then free for another transmission (Figure 2).

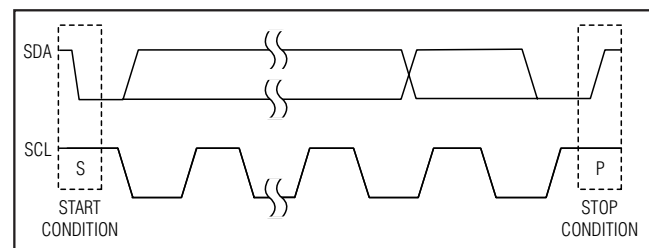

Figure 2. Start and Stop Conditions

2-Wire Interfaced, 3V to 5.5V, 4-Digit, 9-Segment LED Display Drivers with Keyscan

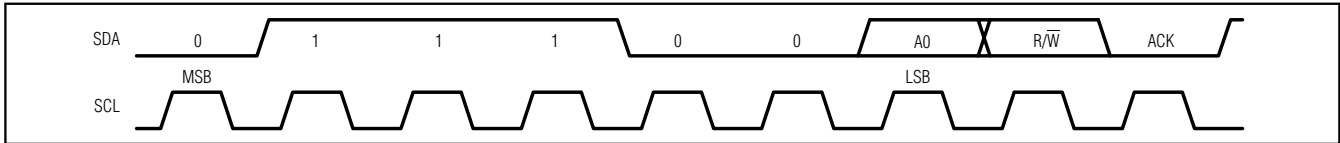

Figure 3. Slave Address

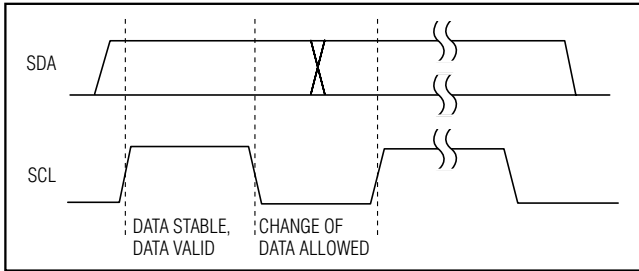

Figure 4. Bit Transfer

Bit Transfer

One data bit is transferred during each clock pulse. The data on the SDA line must remain stable while SCL is high (Figure 4).

Acknowledge

The acknowledge bit is a clocked 9th bit that the recipient uses to handshake receipt of each byte of data (Figure 5). Thus, each byte transferred effectively requires 9 bits. The master generates the 9th clock pulse, and the recipient pulls down SDA during the acknowledge clock pulse, such that the SDA line is stable low during the high period of the clock pulse. When the master is transmitting to the MAX6958/MAX6959, the MAX6958/MAX6959 generate the acknowledge bit because the MAX6958/MAX6959 are the recipients. When the MAX6958/MAX6959 are transmitting to the master, the master generates the acknowledge bit because the master is the recipient.

Slave Address

The MAX6958/MAX6959 have a 7-bit-long slave address (Figure 3). The eighth bit following the 7-bit slave address is the R/W bit. Set the R/W bit low for a write command and high for a read command.

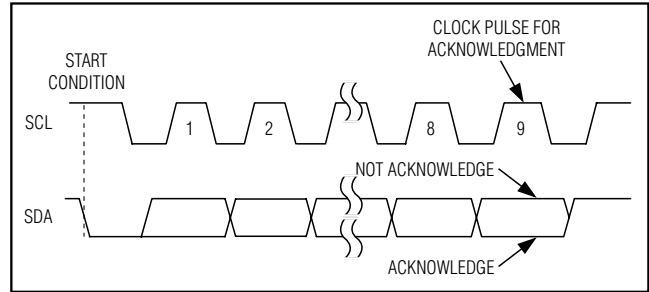

Figure 5. Acknowledge

The MAX6958/MAX6959 are available in one of two possible slave addresses (see Table 2 and *Ordering Information*). The first 6 bits (MSBs) of the MAX6958/MAX6959 slave address are always 011100. Slave address bit A0 is internally hardwired to either GND in the MAX695_A_, or V+ in the MAX695_B_. A maximum of two MAX6958/MAX6959 devices can share a bus.

Message Format for Writing

A write to the MAX6958/MAX6959 comprises the transmission of the MAX6958/MAX6959's slave address with the R/W bit set to zero, followed by at least 1 byte of information. The first byte of information is the command byte, which determines the register that stores the next byte written to the MAX6958/MAX6959. If a STOP condition is detected after the command byte is received, the MAX6958/MAX6959 take no further action (Figure 6) beyond storing the command byte.

Table 2. MAX6958/MAX6959 Address Map

SLAVE ADDRESS BIT A0	MAX6958/MAX6959 DEVICE ADDRESS						
	A6	A5	A4	A3	A2	A1	A0
MAX695_A_	0	1	1	1	0	0	0
MAX695_B_	0	1	1	1	0	0	1

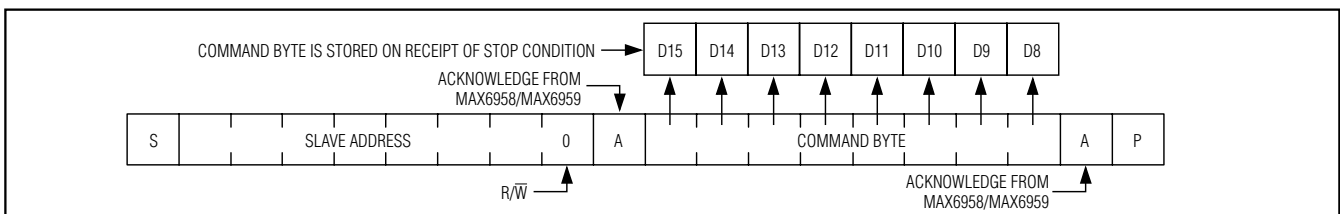

Figure 6. Command Byte Received

2-Wire Interfaced, 3V to 5.5V, 4-Digit, 9-Segment LED Display Drivers with Keyscan

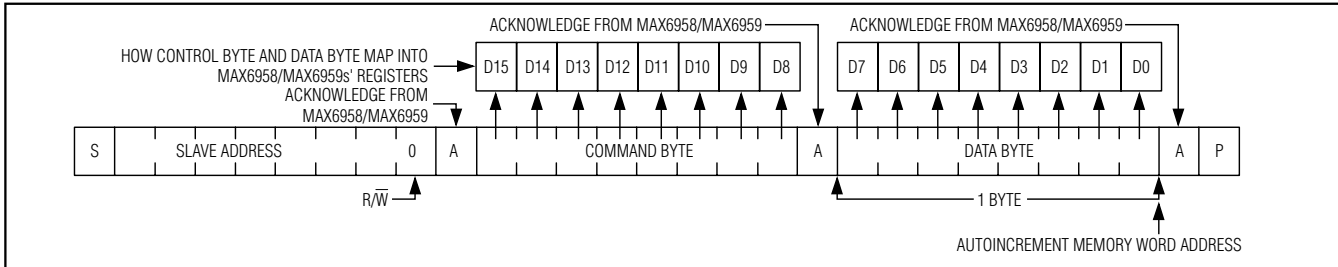

Figure 7. Command and Single Data Byte Received

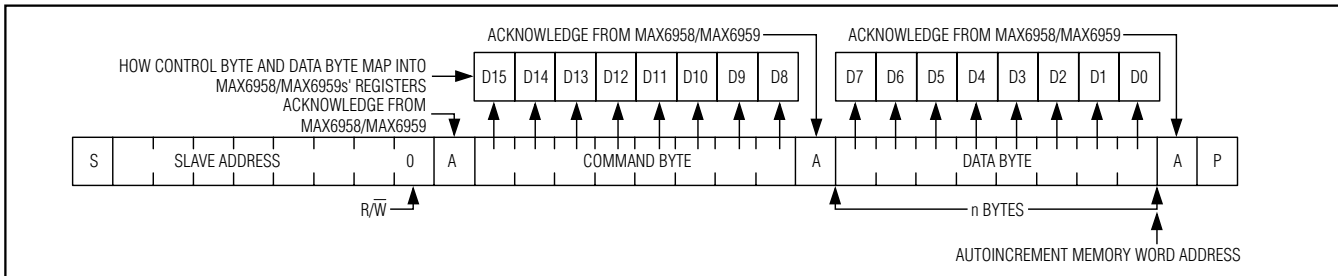

Figure 8. n Data Bytes Received

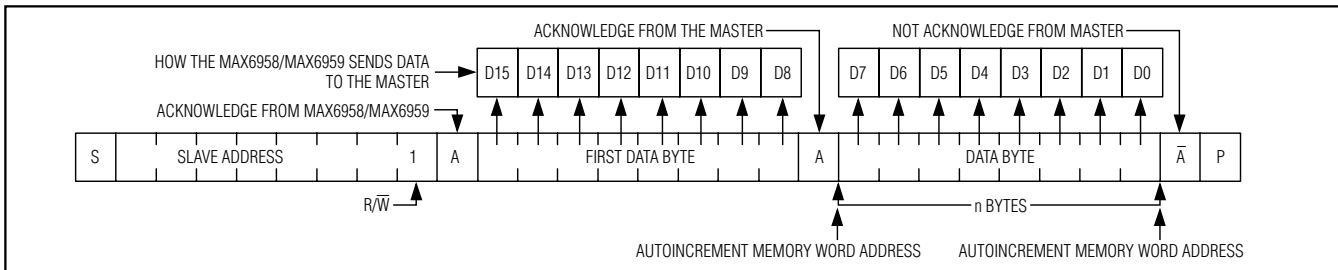

Figure 9. Reading n Data Bytes from the MAX6958/MAX6959

Bytes received after the command byte are data bytes. The first data byte goes into the internal register of the MAX6958/MAX6959 as selected by the command byte (Figure 7).

The address pointer in the MAX6958/MAX6959 autoincrements after each data byte. If multiple data bytes are transmitted before a STOP condition is detected, these bytes are stored in subsequent MAX6958/MAX6959 internal registers (Figure 8), unless the address pointer has reached address 01111111. The address pointer does not autoincrement once address 01111111 has been reached (Table 3).

Message Format for Reading

The MAX6958/MAX6959 are read using the internally stored command byte as an address pointer the same way the stored command byte is used as an address pointer for a write. The pointer autoincrements after

each data byte read using the same rules as for a write (Table 3). A read is initiated by first configuring the MAX6958/MAX6959s' command byte with a write command (Figure 6). The master can now read n consecutive bytes from the MAX6958/MAX6959. The master acknowledges receipt of each read byte during the acknowledge clock pulse. The master must acknowledge all consecutive bytes received except the last byte. The final read byte must be followed by a not acknowledge from the master and then a stop condition (Figure 9). The first data byte is read from the register addressed by the initialized command byte (Figure 8). Reset the address pointer when performing read-after-write verification because the stored byte address is autoincremented after the write. The address pointer does not autoincrement if it points to register 01111111 (Table 3).

Table 4 is the register address map.

2-Wire Interfaced, 3V to 5.5V, 4-Digit, 9-Segment LED Display Drivers with Keyscan

MAX6958/MAX6959

Table 3. Command Address Autoincrement Behavior

COMMAND BYTE ADDRESS RANGE	AUTOINCREMENT BEHAVIOR
00000000 to 01111110	Command byte address autoincrements after byte read or written
01111111	Command byte address remains at 01111111 after byte written or read

Operation with Multiple Masters

If the MAX6958/MAX6959 are operated on a 2-wire interface with multiple masters, a master reading the MAX6958/MAX6959 should use a repeated start between the write, which sets the MAX6958/MAX6959s' address pointer, and the read(s) that takes the data from the location(s) set by the address pointer. It is possible for master 2 to take over the bus after master 1 has set up the MAX6958/MAX6959s' address pointer but before master 1 has read the data. If master 2 subsequently changes the MAX6958/MAX6959s' address pointer, then master 1's delayed read may be from an unexpected location.

Command Address Autoincrementing

Address autoincrementing allows the MAX6958/MAX6959 to be configured with the shortest number of transmissions by minimizing the number of times the command byte needs to be sent. The address pointer stored in the MAX6958/MAX6959 increments after each data byte is written or read, unless the address equals 01111111 (Table 3).

Digit Type Registers

The MAX6958/MAX6959 store display data in five registers. The four digit registers each control the seven numeric segments of a seven-segment digit, but not the DP segments. The segments register controls eight individual LEDs, which can be any mix of discrete LEDs and any or all of the DP segments of the four 7-segment digits (Table 5) (Figure 10).

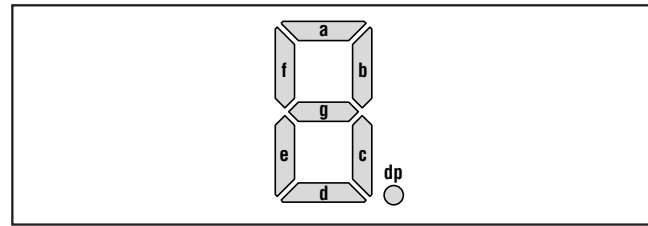

Figure 10. Segment Labeling for 7-Segment Display

Table 4. Register Address Map

REGISTER	COMMAND ADDRESS								HEX CODE
	D15	D14	D13	D12	D11	D10	D9	D8	
No-op	0	0	0	0	0	0	0	0	0x00
Decode mode	0	0	0	0	0	0	0	1	0x01
Intensity	0	0	0	0	0	0	1	0	0x02
Scan limit	0	0	0	0	0	0	1	1	0x03
Configuration	0	0	0	0	0	1	0	0	0x04
Factory reserved. Do not write to this register.	0	0	0	0	0	1	0	1	0x05
GPIO (MAX6959 only)	0	0	0	0	0	1	1	0	0x06
Display test	0	0	0	0	0	1	1	1	0x07
Read key debounced (MAX6959 only) A write to this register is ignored.	0	0	0	0	1	0	0	0	0x08
Read key pressed (MAX6959 only) A write to this register is ignored.	0	0	0	0	1	1	0	0	0x0C
Digit 0	0	0	1	0	0	0	0	0	0x20
Digit 1	0	0	1	0	0	0	0	1	0x21
Digit 2	0	0	1	0	0	0	1	0	0x22
Digit 3	0	0	1	0	0	0	1	1	0x23
Segments	0	0	1	0	0	1	0	0	0x24

2-Wire Interfaced, 3V to 5.5V, 4-Digit, 9-Segment LED Display Drivers with Keyscan

Table 5. No-Decode Mode Data Bits and Corresponding Segment Lines

DIGIT/SEGMENT REGISTER	ADDRESS CODE (HEX)	REGISTER DATA							
		D7	D6	D5	D4	D3	D2	D1	D0
Digit 0	0x20	X	SEG a	SEG b	SEG c	SEG d	SEG e	SEG f	SEG g
Digit 1	0x21	X	SEG a	SEG b	SEG c	SEG d	SEG e	SEG f	SEG g
Digit 2	0x22	X	SEG a	SEG b	SEG c	SEG d	SEG e	SEG f	SEG g
Digit 3	0x23	X	SEG a	SEG b	SEG c	SEG d	SEG e	SEG f	SEG g
Segments	0x24	SEG 7	SEG 6	SEG 5	SEG 4	SEG 3	SEG 2	SEG 1	SEG 0

The digit registers and segments register use 1 bit to set the state of one segment. Each bit is high to turn a segment on, or low to turn it off (Table 6).

Table 6. No-Decode Mode Data Bits and Corresponding Segment Lines

REGISTER BIT	SEGMENT BEHAVIOR
0	Segment off
1	Segment on

Decode-Mode Register

The decode-mode register sets hexadecimal code (0–9, A–F) or no-decode operation for each digit. Each bit in the register corresponds to one digit. Logic high selects hexadecimal decoding while logic low bypasses the decoder. Digits can be set for decode or no decode in any combination. Bit assignment and examples of the decode mode control register format are shown in Table 7.

Table 7. Decode-Mode Register Examples

DECODE MODE	ADDRESS CODE (HEX)	REGISTER DATA								HEX CODE
		D7	D6	D5	D4	D3	D2	D1	D0	
Bit assignment for each digit	0x01	X	X	X	X	Digit 3	Digit 2	Digit 1	Digit 0	—
No decode for digits 3–0	0x01	X	X	X	X	0	0	0	0	0xX0
Hexadecimal decode for digit 0; no decode for digits 3–1	0x01	X	X	X	X	0	0	0	1	0xX1
—	—	—	—	—	—	—	—	—	—	—
Hexadecimal decode for digits 2–0; no decode for digit 3	0x01	X	X	X	X	0	1	1	1	0xX7
Hexadecimal decode for digit 3; no decode for digits 2–0	0x01	X	X	X	X	1	0	0	0	0xX8
—	—	—	—	—	—	—	—	—	—	—
Hexadecimal decode for digits 3–0	0x01	X	X	X	X	1	1	1	1	0xXF

In hexadecimal code-decode mode, the decoder looks only at the lower nibble of the data in the digit register (D3–D0), disregarding bits D7–D4. Table 7 lists the hexadecimal code font. When no decode is selected, data bits D7–D0 correspond to the segment lines of the MAX6958/MAX6959. Table 8 shows the one-to-one pairing of each data bit to the appropriate segment line.

Initial Power-Up

On initial power-up, all control registers are reset, the display is blanked, and the MAX6958/MAX6959 enter shutdown mode (Table 9). At power-up, the MAX6958/MAX6959 are initially set to scan four digits, do not decode data in the digit registers or scan key switches (MAX6959 only), and the intensity register is set to a low value (4/64 intensity).

2-Wire Interfaced, 3V to 5.5V, 4-Digit, 9-Segment LED Display Drivers with Keyscan

MAX6958/MAX6959

Table 8. Seven-Segment Mapping Decoder for Hexadecimal Font

7-SEGMENT CHARACTER	REGISTER DATA					ON SEGMENTS = 1						
	D7–D4	D3	D2	D1	D0	a	b	c	d	e	f	g
0	X	0	0	0	0	1	1	1	1	1	1	0
1	X	0	0	0	1	0	1	1	0	0	0	0
2	X	0	0	1	0	1	1	0	1	1	0	1
3	X	0	0	1	1	1	1	1	1	0	0	1
4	X	0	1	0	0	0	1	1	0	0	1	1
5	X	0	1	0	1	1	0	1	1	0	1	1
6	X	0	1	1	0	1	0	1	1	1	1	1
7	X	0	1	1	1	1	1	1	0	0	0	0
8	X	1	0	0	0	1	1	1	1	1	1	1
9	X	1	0	0	1	1	1	1	1	0	1	1
A	X	1	0	1	0	1	1	1	0	1	1	1
B	X	1	0	1	1	0	0	1	1	1	1	1
C	X	1	1	0	0	1	0	0	1	1	1	0
D	X	1	1	0	1	0	1	1	1	1	0	1
E	X	1	1	1	0	1	0	0	1	1	1	1
F	X	1	1	1	1	1	0	0	0	1	1	1

Table 9. Initial Power-Up Register Status

REGISTER	POWER-UP CONDITION	ADDRESS CODE (HEX)	REGISTER DATA							
			D7	D6	D5	D4	D3	D2	D1	D0
Decode mode	No decode for digits 3–0	0x01	X	X	X	X	0	0	0	0
Intensity	4/64 intensity	0x02	X	X	0	0	0	0	1	0
Scan limit	Display 4 digits: 0 1 2 3	0x03	X	X	X	X	X	X	X	1
Configuration	Shutdown enabled	0x04	X	X	0	X	X	X	X	D bit
GPIO*	IRQ/SEG9 is a segment output (not IRQ or logic output); INPUT2 and INPUT1 are logic inputs; IRQ flag is clear	0x06	1	0	0	0	0	0	X	X
Display test	Normal operation	0x07	X	X	X	X	X	X	X	X
Key debounced*	No key detected as debounced	0x08	0	0	0	0	0	0	0	0
Key pressed*	No key detected as pressed	0x0C	0	0	0	0	0	0	0	0
Digit 0	Blank digit (because not decoded)	0x20	X	0	0	0	0	0	0	0
Digit 1	Blank digit (because not decoded)	0x21	X	0	0	0	0	0	0	0
Digit 2	Blank digit (because not decoded)	0x22	X	0	0	0	0	0	0	0
Digit 3	Blank digit (because not decoded)	0x23	X	0	0	0	0	0	0	0
Segments	Blank segments	0x24	0	0	0	0	0	0	0	0

*MAX6959 only.

2-Wire Interfaced, 3V to 5.5V, 4-Digit, 9-Segment LED Display Drivers with Keyscan

Configuration Register

Use the configuration register to enter and exit shutdown, check device type, and globally clear the digit data (Tables 10–13). The S bit selects shutdown or normal operation (read/write). The D bit reports whether the device is a MAX6958 or a MAX6959 (read only). The R bit clears all the digit and segment data (data is not stored-transient bit)

Scan-Limit Register

The scan-limit register sets the number of digits displayed, from one to four (Table 14). A bicolor digit is connected as two monochrome digits. The scan-limit register also limits the number of keys that can be

scanned. Since the number of scanned digits affects the display brightness, the scan-limit register should not be used to blank portions of the display (such as leading zero suppression).

Intensity Register

An internal pulse-width modulator controlled by the intensity register provides digital control of display brightness. The modulator scales the average segment current in 63 steps from a maximum of 63/64 down to 1/64 of the 23mA peak current. The minimum interdigit blanking time is set to 1/64 of a cycle (Figure 11 and Table 15).

Table 10. Configuration Register Format

MODE	ADDRESS CODE (HEX)	REGISTER DATA							
		D7	D6	D5	D4	D3	D2	D1	D0
Configuration register	0x04	X	X	R	X	X	X	D	S

Table 11. Shutdown Control (S Data Bit D0) Format

MODE	ADDRESS CODE (HEX)	REGISTER DATA							
		D7	D6	D5	D4	D3	D2	D1	D0
Shutdown mode	0x04	X	X	R	X	X	X	D	0
Normal operation	0x04	X	X	R	X	X	X	D	1

Table 12. Device Readback (D Data Bit D1) Format

MODE	ADDRESS CODE (HEX)	REGISTER DATA							
		D7	D6	D5	D4	D3	D2	D1	D0
MAX6958	0x04	X	X	R	X	X	X	0	S
MAX6959	0x04	X	X	R	X	X	X	1	S

Table 13. Global Clear Digit Data (R Data Bit D5) Format

MODE	ADDRESS CODE (HEX)	REGISTER DATA							
		D7	D6	D5	D4	D3	D2	D1	D0
Digit and segment data are unaffected	0x04	X	X	0	X	X	X	D	S
Digit and segment data are cleared	0x04	X	X	1	X	X	X	D	S

Table 14. Scan-Limit Register Format

SCAN LIMIT	ADDRESS CODE (HEX)	REGISTER DATA								HEX CODE
		D7	D6	D5	D4	D3	D2	D1	D0	
Display digit 0 and segments 0, 4	0x03	X	X	X	X	X	X	0	0	0xX0
Display digits 0, 1 and segments 0, 1, 4, 5	0x03	X	X	X	X	X	X	0	1	0xX1
Display digits 0, 1, 2 and segments 0, 1, 2, 4, 5, 6	0x03	X	X	X	X	X	X	1	0	0xX2
Display digits 0, 1, 2, 3 and segments 0, 1, 2, 3, 4, 5, 6, 7	0x03	X	X	X	X	X	X	1	1	0xX3

2-Wire Interfaced, 3V to 5.5V, 4-Digit, 9-Segment LED Display Drivers with Keyscan

MAX6958/MAX6959

Table 15. Global Intensity Register Format

DUTY CYCLE	TYPICAL SEGMENT CURRENT (mA)	ADDRESS CODE (HEX)	D7	D6	D5	D4	D3	D2	D1	D0	HEX CODE
1/64 (min on)	0.36	0x02	X	X	0	0	0	0	0	0	0x00
2/64	0.72	0x02	X	X	0	0	0	0	0	1	0x01
3/64	1.08	0x02	X	X	0	0	0	0	1	0	0x02
4/64	1.44	0x02	X	X	0	0	0	0	1	1	0x03
5/64	1.80	0x02	X	X	0	0	0	1	0	0	0x04
6/64	2.16	0x02	X	X	0	0	0	1	0	1	0x05
—	—	0x02	X	X	—	—	—	—	—	—	—
60/64	21.56	0x02	X	X	1	1	1	0	1	1	0x3B
61/64	21.92	0x02	X	X	1	1	1	1	0	0	0x3C
62/64	22.28	0x02	X	X	1	1	1	1	1	0	0x3D
63/64	22.64	0x02	X	X	1	1	1	1	1	1	0x3E
63/64 (max on)	22.64	0x02	X	X	1	1	1	1	1	1	0x3F

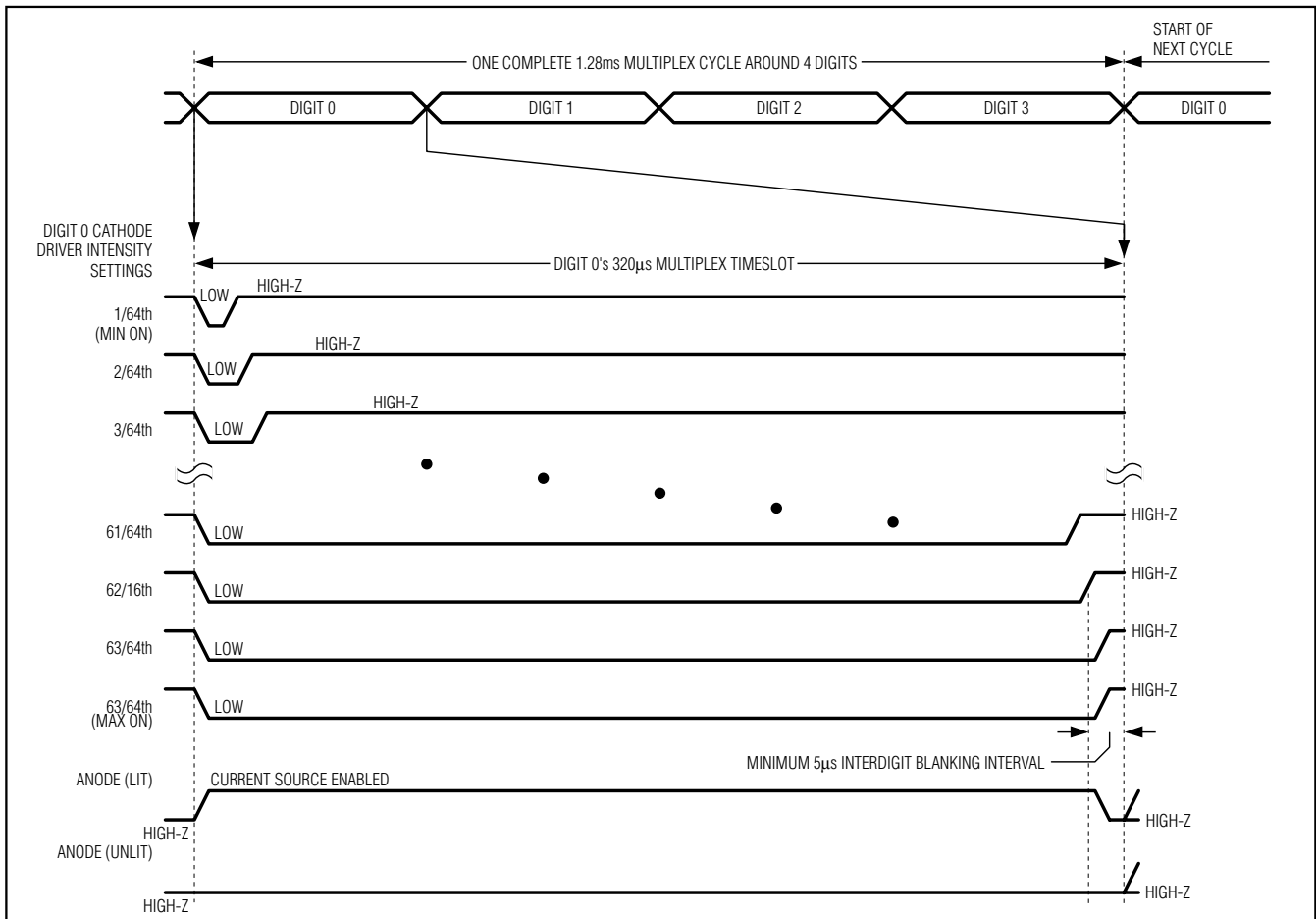

Figure 11. Multiplex Timing Diagram

2-Wire Interfaced, 3V to 5.5V, 4-Digit, 9-Segment LED Display Drivers with Keyscan

Ports and Key Scanning (MAX6959 Only)

The MAX6959 features two input ports, INPUT1 and INPUT2. These two ports can be used as general-purpose logic inputs, or configured to perform automatic keyscanning. Both ports have internal pullup resistors enabled in shutdown and normal operation for both general-purpose input mode and keyscanning mode. The ports can be read using the 2-wire interface.

The keyscan logic uses one or both of the INPUT1 and INPUT2 logic inputs (Figure 12). An interrupt output that flags key presses is optional. The interrupt flag can be read (polled) through the serial interface instead, allowing IRQ/SEG9 to be used as an open-drain general-purpose logic output or as a segment driver.

One small-signal diode is required per key switch when more than one key is connected to INPUT1 or INPUT2. The diodes prevent two simultaneous key switch depressions from shorting digit drivers together. For example, if KEY0 and KEY1 were pressed together (Figure 12) and the diodes were not fitted, DIG0/SEG0 and DIG1/SEG1 would be shorted together and the LED multiplexing would be incorrect. These diodes can be common-anode dual diodes in SOT23 like BAW56. A diode is not required for a single key connection to INPUT1 or INPUT2. Therefore, up to two key switches can be directly connected without adding diodes (Figure 13).

Resistors R1 and R2 are required if the MAX6959 is operated with V_+ greater than 4V. R1 and R2 are optional if V_+ is between 3V and 4V.

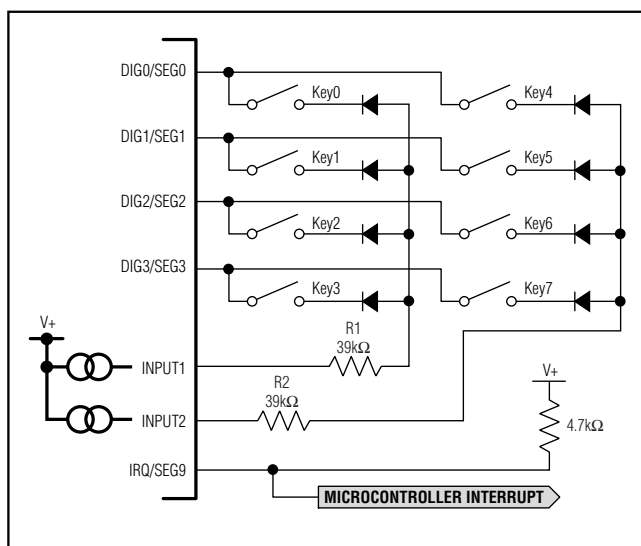

Figure 12. Maximum Keyscan Configuration

The keyscanning circuit utilizes the LED's common-cathode driver outputs as the keyscan drivers. The outputs DIG0/SEG0 to DIG3/SEG3 pulse low for nominally 320 μ s sequentially as the displays are multiplexed. The actual low time varies from 5 μ s to 315 μ s due to pulse-width modulation from 1/64th to 63/64th for intensity control. The timing diagram (Figure 14) shows the typical situation when all four LED cathode drivers are used. The maximum eight keys can be scanned only if the scan-limit register is set to scan the maximum four digits. If fewer than four digits are driven, then only (2 x n) switches can be scanned, where n is the number of digits (1, 2, 3, or 4) set in the scan-limit register (Table 14).

The keyscan cycle loops continuously over time, with all eight keys experiencing a full keyscanning debounce over 41ms (Figure 14). A key press is debounced and an interrupt issued if at least one key that was not pressed in a previous cycle is found pressed during both sampling periods. The keyscan circuit detects any combination of keys pressed during each debounce cycle (n-key rollover).

Port Configuration Register (MAX6959 Only)

The port configuration register configures INPUT1, INPUT2, and IRQ/SEG9 ports for the MAX6959 (Table 16).

IRQ/SEG9 can be set to either an LED segment output (driving four multiplexed LED segments), or an open-drain logic output. The open-drain logic output can be configured as either an IRQ output controlled by the keyscan circuitry, or as a general-purpose logic output controlled through the 2-wire interface. Connect a

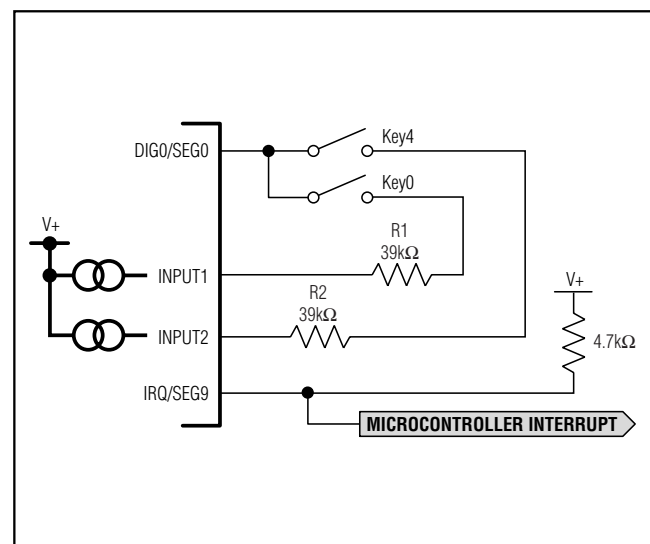

Figure 13. Keyscanning Two Keys Without Diodes

2-Wire Interfaced, 3V to 5.5V, 4-Digit, 9-Segment LED Display Drivers with Keyscan

MAX6958/MAX6959

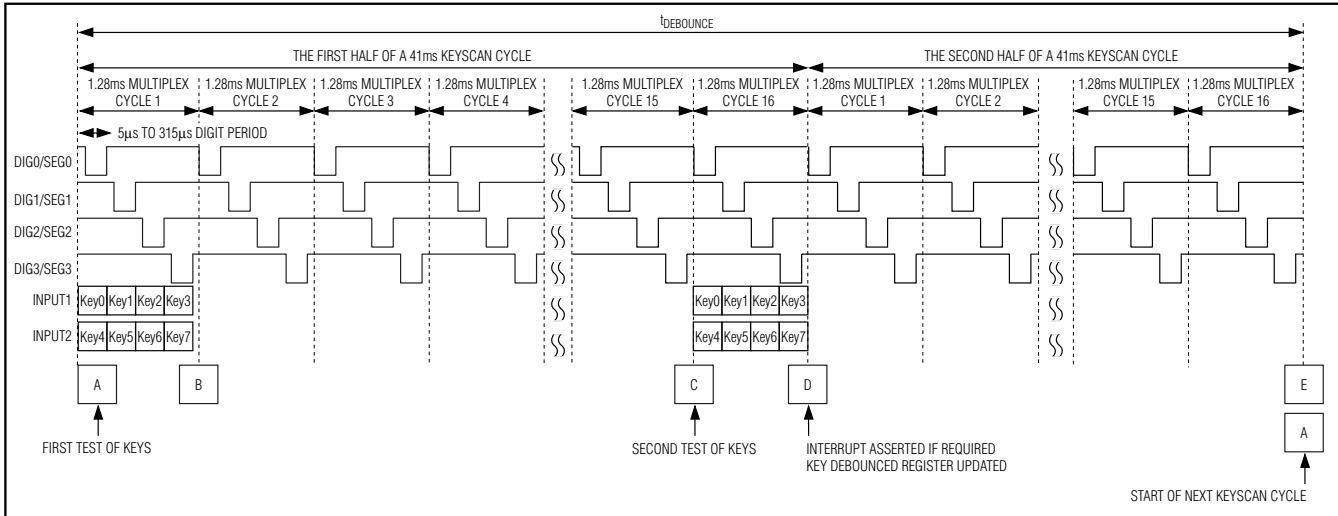

Figure 14. Keyscan Timing Diagram

pullup resistor from IRQ/SEG9 to a voltage no greater than 5.5V when configuring IRQ/SEG9 as an interrupt or logic output.

INPUT1 and INPUT2 can be individually configured as either general-purpose logic inputs or as keyscan inputs. In either mode, the input structure is the same—CMOS logic inputs with internal pullup resistors. The

pullups are always enabled, even in shutdown. Ensure these inputs are either close to V+ or open circuit for minimum shutdown supply current. If both INPUT1 and INPUT2 are assigned to keyscan, then eight keys can be debounced. If only INPUT1 or INPUT2 is assigned to keyscan, then only four keys can be debounced.

Table 16. Port Configuration Register Format

MODE	ADDRESS CODE (HEX)	REGISTER DATA								
		D7	D6	D5	D4	D3	D2	D1	D0	
This is the bit assignment:										
Read GPIO register	0x06	Read back IRQ/SEG9 configuration		Read back INPUT 2 configuration		Read back INPUT 1 configuration		INPUT2 logic level	INPUT1 logic level	IRQ status (1 = interrupt)
Write GPIO register	0x06	Configure IRQ/SEG9 output		Configure INPUT 2: 0 = logic input 1 = keyscan		Configure INPUT 1: 0 = logic input 1 = keyscan		X	X	X
Here are the IRQ/SEG9 allocation options, determined by the settings of D7, D6, D5:										
IRQ/SEG9 is logic 0 output	0x06	0	0	0	X	X	X	X	X	
IRQ/SEG9 is logic 1 output	0x06	0	0	1	X	X	X	X	X	
IRQ/SEG9 is active-low IRQ	0x06	0	1	0	X	X	X	X	X	
IRQ/SEG9 is active-high IRQ	0x06	0	1	1	X	X	X	X	X	
IRQ/SEG9 is segment driver	0x06	1	X	X	X	X	X	X	X	

2-Wire Interfaced, 3V to 5.5V, 4-Digit, 9-Segment LED Display Drivers with Keyscan

Key Debounced Register (MAX6959 Only)

The key debounced register shows which keys have been detected as debounced by the keyscanning circuit (Table 17). Each bit in the register corresponds to one key switch. The bit is set to 1 if the switch has been correctly debounced since the last key debounced register read operation.

Reading the key debounced register clears the register (after the data has been read) so that future key presses can be identified. If the key debounced register is not read, the keyscan data accumulates. There is no FIFO register in the MAX6959. Key-press order, or whether a key has been pressed more than once, cannot be determined unless the key debounced register is read after each interrupt and before completion of the next keyscan cycle.

Reading the key debounced register clears the IRQ output. If a key is pressed and held down, the key is reported as debounced (and an IRQ is issued) only once. The key must be detected as released by the keyscanning circuit before it is debounced again.

The key debounced register is read only. A write to address 0x08 is ignored.

Key Pressed Register (MAX6959 Only)

The key pressed register shows which keys have been detected as pressed by the keyscanning circuit during the last test. Each bit in the register corresponds to one key switch. The bit is set if the switch has been detected as pressed by the keyscanning circuit during the last test. The bit is cleared if the switch has not been

detected as pressed by the keyscanning circuit during the last test. Reading the key pressed register does not clear either the key pressed register, or the key debounced register, and does not clear the IRQ output.

The key pressed register is read only. A write to address 0x0C is ignored.

Display Test Register

The display test register operates in two modes: normal and display test (Table 19). Display test mode turns on all LEDs by overriding, but not altering, all control and digit registers (including the shutdown register) except for the port configuration register. The duty cycle while in display test mode is 28/64.

Applications Information

Driving Bicolor LEDs

Bicolor digits combine a red and a green die for each display element, so that the element displays red or green (or orange), depending on which die (or both) is lit. The MAX6958/MAX6959 treat a bicolor digit as two monocolored digits.

Low-Voltage Operation

The MAX6958/MAX6959 are guaranteed to drive a 23mA segment current into 2.4V (or lower) LEDs when operated from a supply voltage of 4.5V to 5.5V. Operating the MAX6958/MAX6959 from a supply voltage lower than 4.5V reduces the LED drive current. The drivers drive at least 15.5mA segment current into 2V (or lower) LEDs when operated from a 3V supply voltage.

Table 17. Key Debounced Register Format

KEY DEBOUNCED REGISTER	ADDRESS CODE (HEX)	REGISTER DATA WITH APPROPRIATE SWITCH NAMED BELOW							
		D7	D6	D5	D4	D3	D2	D1	D0
Key debounced register	0x08	Key7	Key6	Key5	Key4	Key3	Key2	Key1	Key0

Table 18. Key Pressed Register Format

KEY PRESSED REGISTER	ADDRESS CODE (HEX)	REGISTER DATA WITH APPROPRIATE SWITCH NAMED BELOW							
		D7	D6	D5	D4	D3	D2	D1	D0
Key pressed register	0x0C	Key7	Key6	Key5	Key4	Key3	Key2	Key1	Key0

Table 19. Display Test Register

MODE	ADDRESS CODE (HEX)	REGISTER DATA							
		D7	D6	D5	D4	D3	D2	D1	D0
Normal operation	0x07	X	X	X	X	X	X	X	0
Display test mode	0x07	X	X	X	X	X	X	X	1

2-Wire Interfaced, 3V to 5.5V, 4-Digit, 9-Segment LED Display Drivers with Keyscan

MAX6958/MAX6959

Computing Power Dissipation

Determine the MAX6958/MAX6959 upper-limit power dissipation (P_D) with the following equation:

$$P_D = (V_+ \times I_+) + (V_+ - V_{LED}) (\text{DUTY} \times I_{SEG} \times N)$$

where:

V_+ = supply voltage

I_+ = operating supply current

DUTY = duty cycle set by intensity register

N = number of segments driven (worst case is nine)

V_{LED} = LED forward voltage at I_{SEG}

I_{SEG} = peak segment current

P_D = power dissipation, in mW if currents are in mA

Dissipation example:

$$\begin{aligned} I_{SEG} &= 23\text{mA}, N = 9, \text{DUTY} = 63/64, V_{LED} = 2.2\text{V}, \\ V_+ &= 5.25\text{V} \\ P_D &= 5.25\text{V} (5.9\text{mA}) + (5.25\text{V} - 2.2\text{V}) \\ & \quad (63/64 \times 23\text{mA} \times 9) = 0.652\text{W} \end{aligned}$$

For a 16-pin DIP package ($T_{JA} = 1/0.0105 = +95.2^\circ\text{C/W}$ from *Absolute Maximum Ratings*), the maximum allowed ambient temperature T_A is given by:

$$\begin{aligned} T_{J(\text{MAX})} &= T_A + (P_D \times T_{JA}) = +150^\circ\text{C} \\ &= T_A + (0.652 \times 95.2^\circ\text{C/W}) \end{aligned}$$

Therefore, $T_A = +87.9^\circ\text{C}$.

Power Supplies

The MAX6958/MAX6959 operate from a single 3V to 5.5V power supply. Bypass V_+ with a 0.1 μF capacitor to GND, as close to the device as possible. Bypass V_+ with an additional 10 μF capacitor if the MAX6958/MAX6959 are not close to the board input's bulk decoupling capacitor.

Chip Information

TRANSISTOR COUNT: 17,340

PROCESS: CMOS

Ordering Information (continued)

PART	TEMP RANGE	SLAVE ADDRESS	PIN-PACKAGE	PKG CODE
MAX6958BAEE	-40°C to +125°C	0111001	16 QSOP	E16-1
MAX6958BAPE	-40°C to +125°C	0111001	16 DIP	P16-1
MAX6959AAEE	-40°C to +125°C	0111000	16 QSOP	E16-1
MAX6959AAPE	-40°C to +125°C	0111000	16 DIP	P16-1
MAX6959BAEE	-40°C to +125°C	0111001	16 QSOP	E16-1
MAX6959BAPE	-40°C to +125°C	0111001	16 DIP	P16-1

Functional Diagram

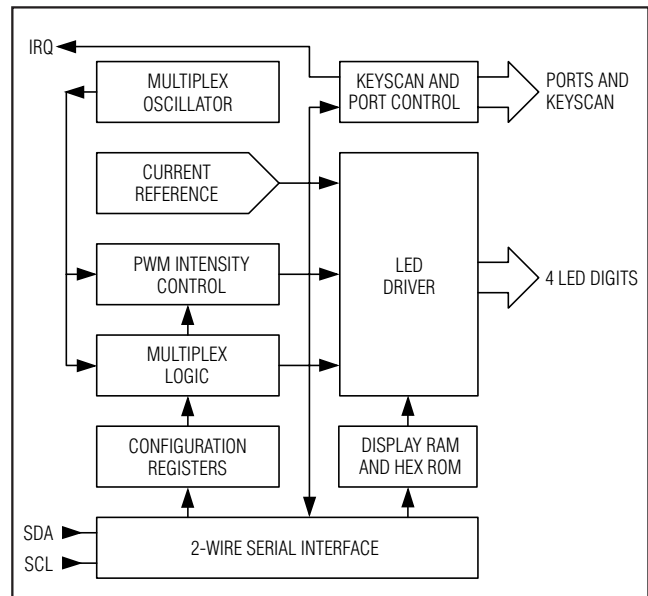

2-Wire Interfaced, 3V to 5.5V, 4-Digit, 9-Segment LED Display Drivers with Keyscan

Pin Configuration

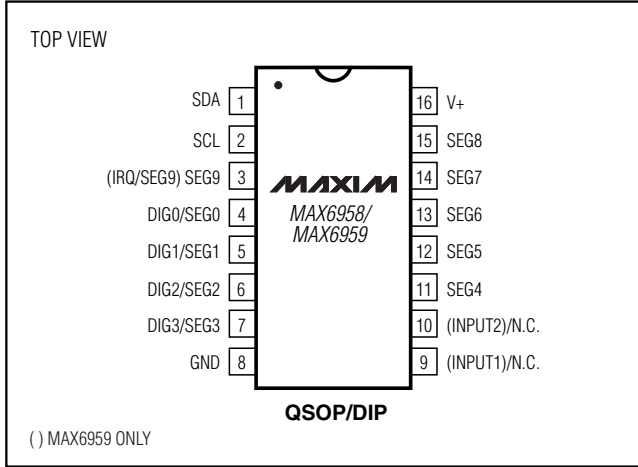

Typical Application Circuit

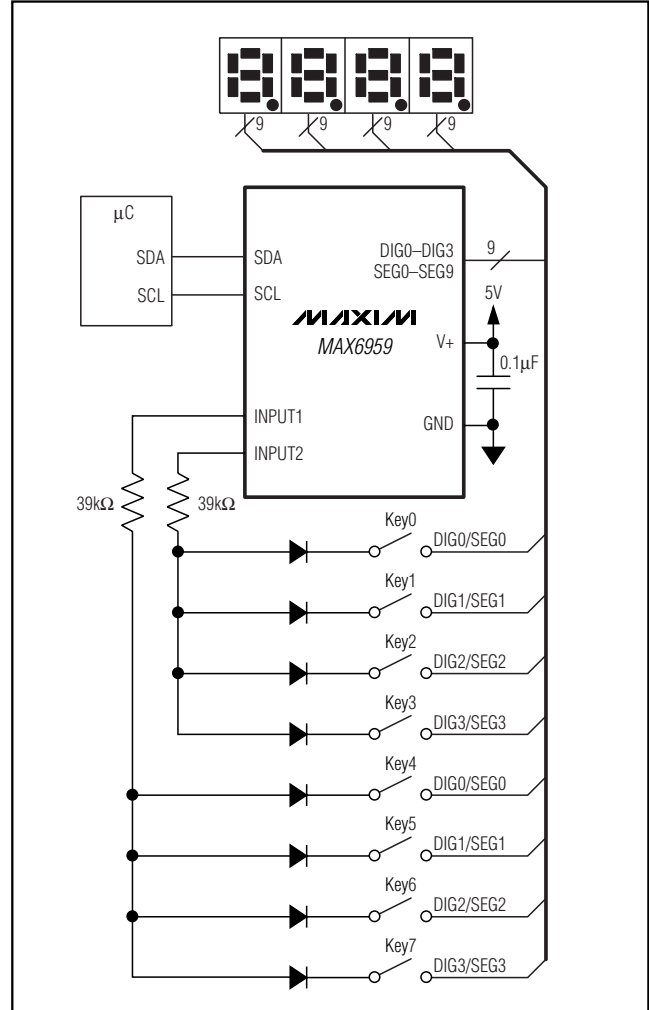

2-Wire Interfaced, 3V to 5.5V, 4-Digit, 9-Segment LED Display Drivers with Keyscan

Package Information

(The package drawing(s) in this data sheet may not reflect the most current specifications. For the latest package outline information, go to www.maxim-ic.com/packages.)

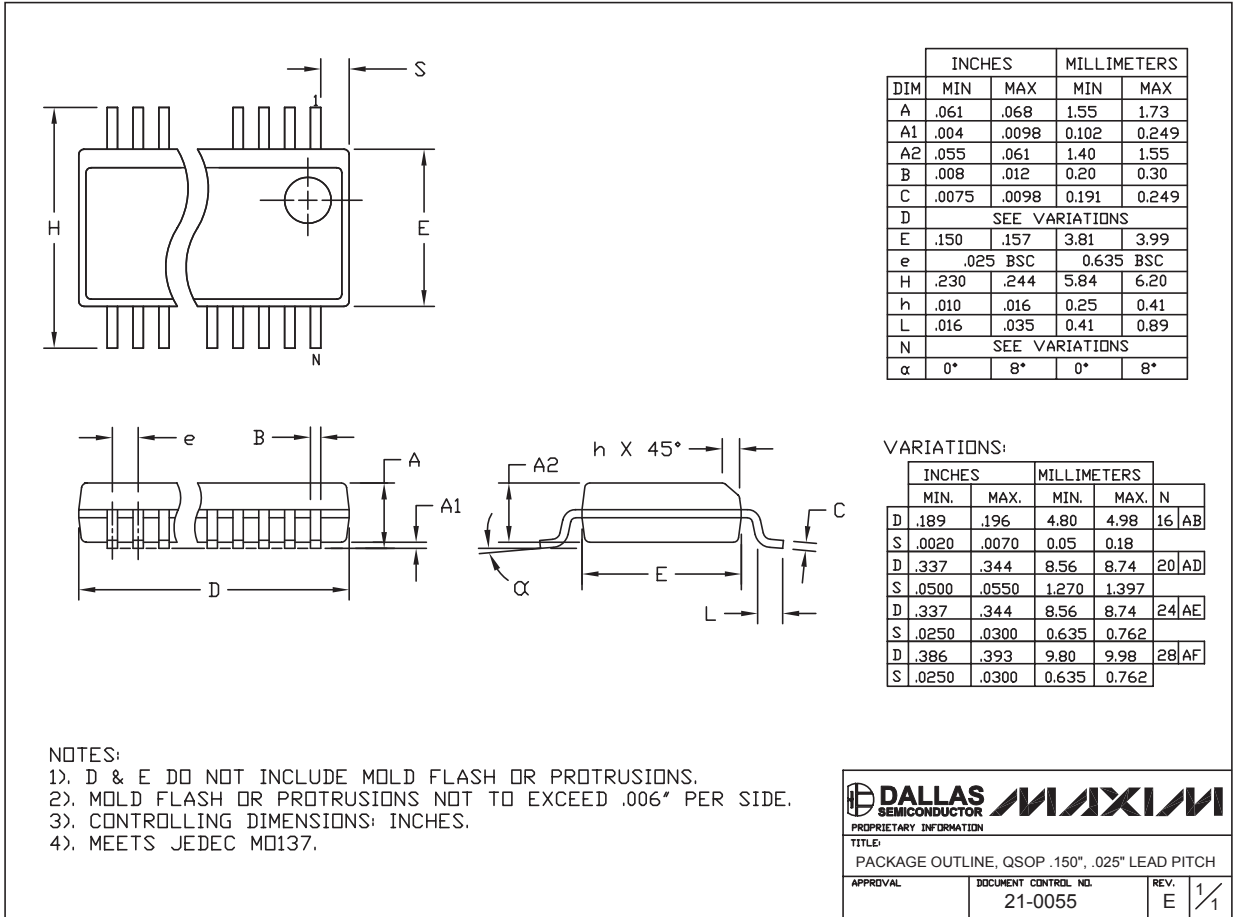

QSOP-EP8S

MAX6958/MAX6959

DALLAS SEMICONDUCTOR **MAXIM**

PROPRIETARY INFORMATION

TITLE:
PACKAGE OUTLINE, QSOP .150", .025" LEAD PITCH

APPROVAL	DOCUMENT CONTROL NO. 21-0055	REV. E	1/1
----------	---------------------------------	-----------	-----

Maxim cannot assume responsibility for use of any circuitry other than circuitry entirely embodied in a Maxim product. No circuit patent licenses are implied. Maxim reserves the right to change the circuitry and specifications without notice at any time.

Maxim Integrated Products, 120 San Gabriel Drive, Sunnyvale, CA 94086 408-737-7600 _____ 19

Looking for pricing, stock, or lifecycle information?

Click below to explore more details on WIN SOURCE:

- ⊖ [View MAX6958AAEE+ on WIN SOURCE](#)
- ⊖ [Maxim Integrated Information](#)

Optimize Your Supply Chain with WIN SOURCE Solutions

- ✓ Global Sourcing Solution
- ✓ Obsolete Management
- ✓ Cost Control Management
- ✓ Shortage Management
- ✓ Alternative Solution
- ✓ Excess Inventory Management