



**THE DATASHEET OF
MAX734ESA+**



Evaluation Kit Manual
Follows Data Sheet

MAXIM

+12V, 120mA Flash Memory Programming Supply

MAX734

General Description

The MAX734 is a +12V-output, step-up, DC-DC switch-mode regulator. It delivers a guaranteed 120mA from a 4.75V input, and is ideal for programming flash memories. Available in 8-pin SO and DIP packages, it uses only a diode, an 18 μ H inductor, and two 33 μ F capacitors. The entire circuit is completely surface-mountable and fits into less than 0.3in². The MAX734 also features a logic-controlled shutdown pin that allows direct microprocessor (μ P) control. In-circuit testing ensures guaranteed output specifications over load, line, and temperature limits.

Battery-saving features include 85% efficiency, 1.2mA operating quiescent supply current, and 70 μ A shutdown supply current. The operating supply current can be reduced to less than 500 μ A by toggling the shutdown pin with the μ P.

The MAX734 uses current-mode pulse-width modulation (PWM) control to provide precise output regulation and low subharmonic noise. A fixed 170kHz oscillator frequency facilitates ripple filtering and allows the use of tiny external capacitors.

For higher-current solutions up to 250mA, refer to the MAX732 data sheet and evaluation kit (MAX732EVKIT-SO).

Applications

- +12V Flash Memory Programming Supplies
- PCMCIA +12V Supplies
- Solid-State Disk Drives
- Palmtop Computers
- Compact +12V Op-Amp Supplies

Pin Configuration

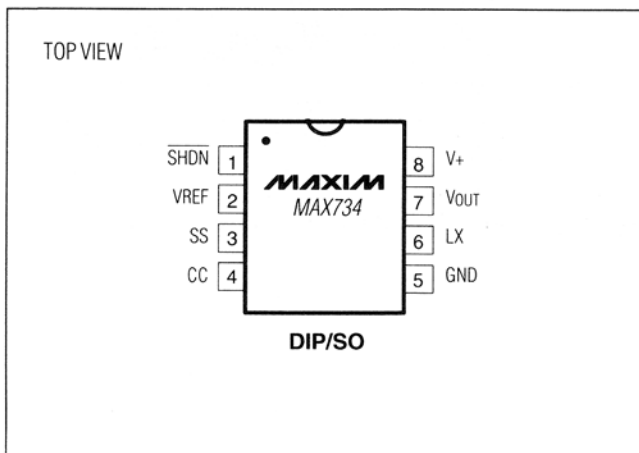

Features

- ◆ Regulated +12V \pm 5% Output
- ◆ Guaranteed 120mA Output Current
- ◆ Tiny Flash Memory Programming Circuit:
Fits into 0.3in²
8-Pin SO and Plastic DIP Packages
Uses Tiny 18 μ H Inductor and 33 μ F Capacitors
- ◆ Logic-Controlled 70 μ A Shutdown
- ◆ 85% Typical Efficiency

Ordering Information

PART	TEMP. RANGE	PIN-PACKAGE
MAX734CPA	0°C to +70°C	8 Plastic DIP
MAX734CSA	0°C to +70°C	8 SO
MAX734C/D	0°C to +70°C	Dice*
MAX734EPA	-40°C to +85°C	8 Plastic DIP
MAX734ESA	-40°C to +85°C	8 SO
MAX734MJA	-55°C to +125°C	8 CERDIP**

* Contact factory for dice specifications.

** Contact factory for availability and processing to MIL-STD-883.

Typical Operating Circuit

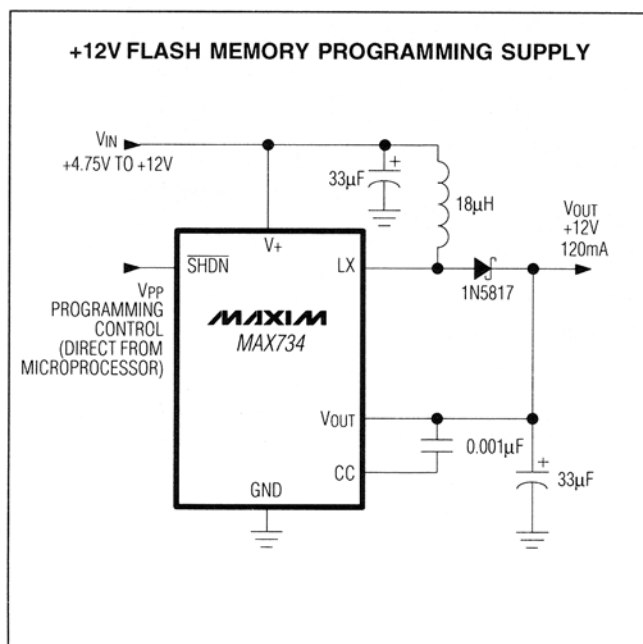

+12V, 120mA Flash Memory Programming Supply

ABSOLUTE MAXIMUM RATINGS

Pin Voltages	
V+, LX	+17V, -0.3V
V _{OUT}	±25V
SS, CC, SHDN	-0.3V to (V+ + 0.3V)
Peak Switch Current (I _{LX})	1.5A
Reference Current (I _{VREF})	2.5mA
Continuous Power Dissipation (T _A = +70°C)	
Plastic DIP (derate 9.09mW/°C above +70°C)	727mW
SO (derate 5.88mW/°C above +70°C)	471mW
CERDIP (derate 8.00mW/°C above +70°C)	640mW

Operating Temperature Ranges:

MAX734C__	0°C to +70°C
MAX734E__	-40°C to +85°C
MAX734MJA	-55°C to +125°C

Junction Temperatures:

MAX734C_/E__	+150°C
MAX734MJA	+175°C

Storage Temperature Range -65°C to +160°C

Lead Temperature (soldering, 10sec) +300°C

Stresses beyond those listed under "Absolute Maximum Ratings" may cause permanent damage to the device. These are stress ratings only, and functional operation of the device at these or any other conditions beyond those indicated in the operational sections of the specifications is not implied. Exposure to absolute maximum rating conditions for extended periods may affect device reliability.

ELECTRICAL CHARACTERISTICS

(Circuit of Figure 1, V+ = 5V, I_{LOAD} = 0mA, T_A = T_{MIN} to T_{MAX}, typical values are at T_A = +25°C, unless otherwise noted.)

PARAMETER	CONDITIONS	MIN	TYP	MAX	UNITS	
Output Voltage	V+ = 4.75V to 12V, Figure 1, 0mA < I _{LOAD} < 120mA	MAX734C/E	11.64	12.12	12.60	V
		MAX734M	11.40	12.12	12.60	
Load Current	V+ = 4.75V, Figure 1	120	150		mA	
	V+ = 4.5V, Figure 2		225			
	V+ = 3.0V, Figure 2		150			
Maximum Input Voltage				V _{OUT}	V	
Line Regulation	V+ = 5V to 12V		0.20		%/V	
Load Regulation	I _{LOAD} = 0mA to 120mA		0.0035		%/mA	
Efficiency	V+ = 5V, I _{LOAD} = 120mA		83		%	
Supply Current	Includes switch current (Note 1)		1.2	2.5	mA	
Standby Current	SHDN = 0, entire circuit		70	100	μA	
	SHDN = 0, into V+		6			
Shutdown Input Threshold	V _{IH}	2.0			V	
	V _{IL}			0.25		
Shutdown Input Leakage Current				1.0	μA	
LX On Resistance	I _{LX} = 500mA		0.5		Ω	
LX Leakage Current	V _{DS} = 12V		1.0		μA	
Reference Voltage			1.23		V	
Reference Drift	T _A = T _{MIN} to T _{MAX}		50		ppm/°C	
Oscillator Frequency			170		kHz	
Compensation Pin Impedance			7500		Ω	

Note 1: Quiescent supply current can be reduced to less than 500μA by pulsing SHDN while supplying 12V to a small load. See *Reducing Operating Supply Current* section.

+12V, 120mA Flash Memory Programming Supply

MAX734

Typical Operating Characteristics

(Circuit of Figure 1, $V_{IN} = +5V$, $V_{OUT} = +12V$, $T_A = +25^{\circ}C$, unless otherwise noted.)

SWITCHING WAVEFORMS - CONTINUOUS CONDUCTION

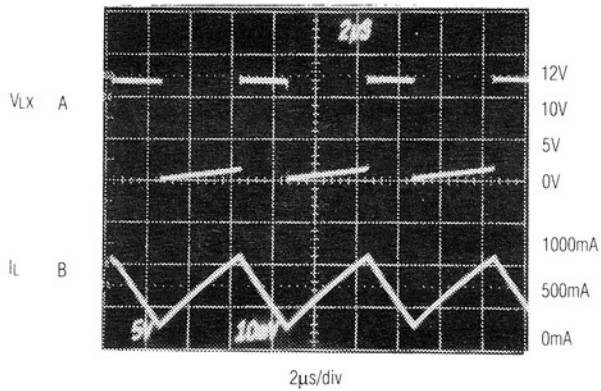

A = LX PIN, 5V/div
B = INDUCTOR CURRENT, 0.5A/div
 $I_{OUT} = 150mA$

SWITCHING WAVEFORMS - DISCONTINUOUS CONDUCTION

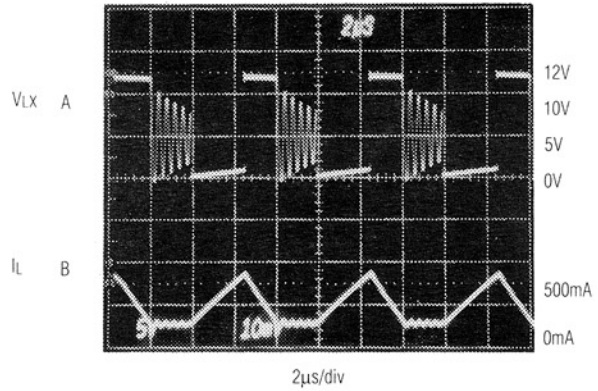

A = LX PIN, 5V/div
B = INDUCTOR CURRENT, 500mA/div
 $I_{OUT} = 50mA$

SHDN RESPONSE TIME

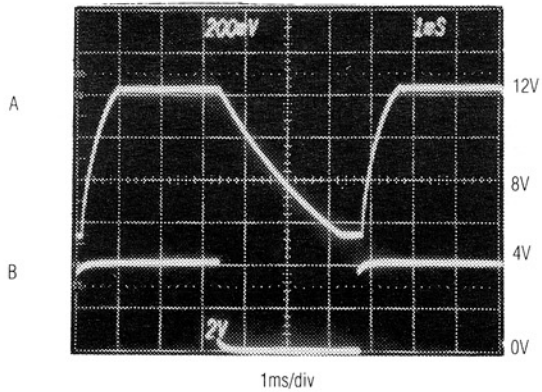

A = V_{OUT} , LOAD = 100Ω
B = SHDN, SS = NO CAPACITOR

LINE-TRANSIENT RESPONSE

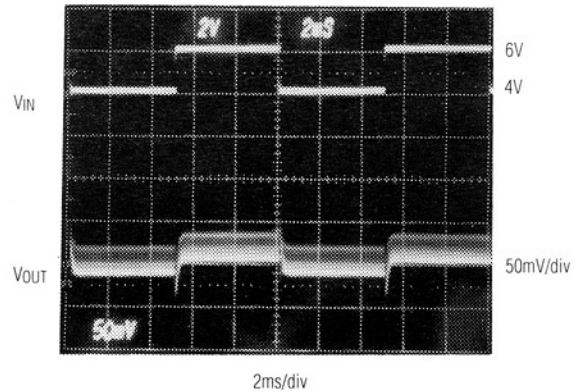

$I_{OUT} = 50mA$

+12V, 120mA Flash Memory Programming Supply

Typical Operating Characteristics (continued)

(Circuit of Figure 1, $V_{IN} = +5V$, $V_{OUT} = +12V$, $T_A = +25^\circ C$, unless otherwise noted.)

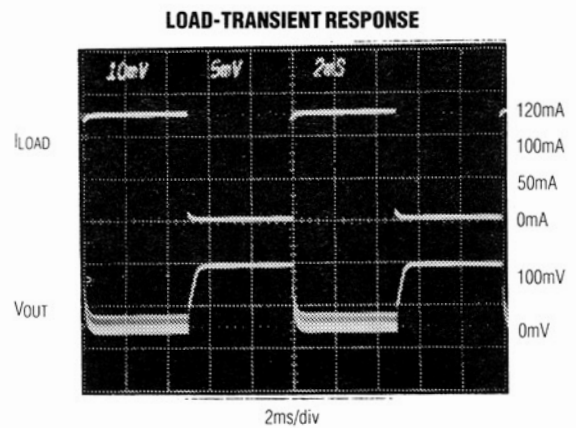
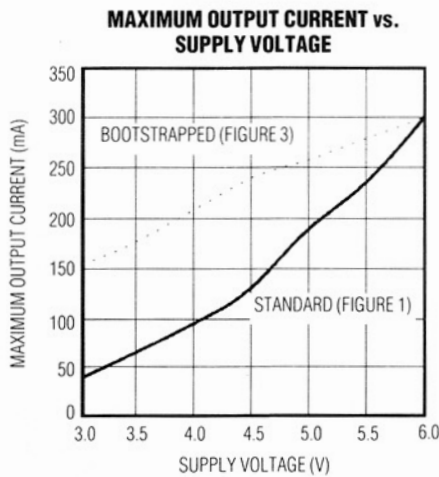
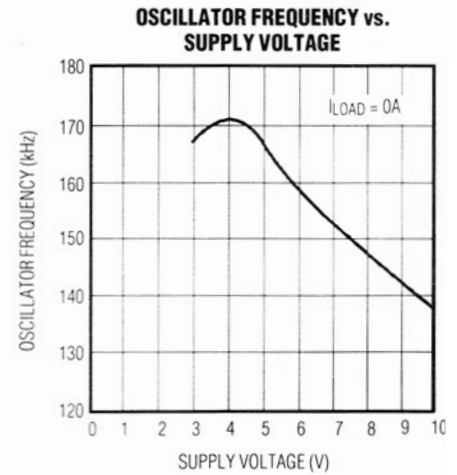
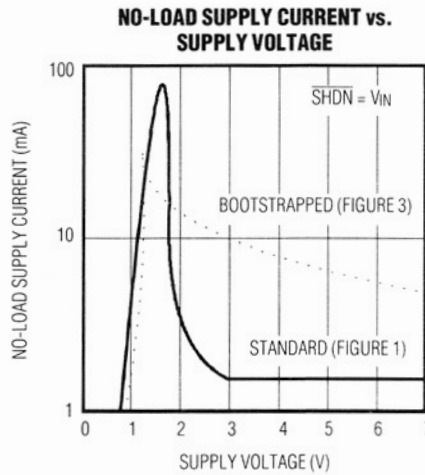
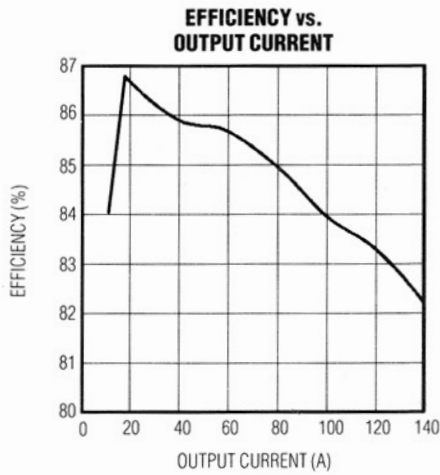

Pin Description

PIN	NAME	FUNCTION
1	SHDN	Shutdown - active low. Connect to ground to shut down the MAX734. Connect to V+ for normal operation. Power switching FET is held off when SHDN is low.
2	VREF	Reference Voltage Output (+1.23V) - supplies up to 100 μA for external loads.
3	SS	Soft-Start. Capacitor between SS and GND provides soft-start and short-circuit protection.
4	CC	Compensation Capacitor Input. Externally compensates the outer feedback loop.
5	GND	Ground
6	LX	Drain of internal N-channel power MOSFET
7	V _{OUT}	Output-Voltage Sense Input. Provides regulation feedback sensing.
8	V+	Supply-Voltage Input. The bypass capacitor must be as close to the device as possible.

+12V, 120mA Flash Memory Programming Supply

MAX734

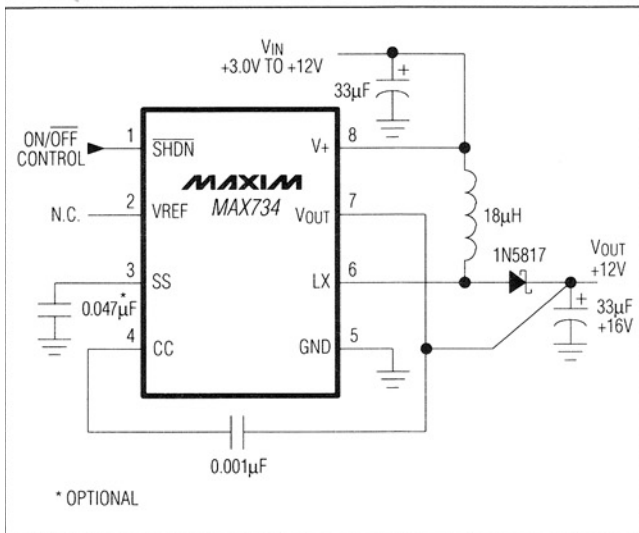

Figure 1. Standard Operating Circuit

Table 1. Typical Soft-Start Times

SUPPLY VOLTAGE (V)	SOFT-START TIME (ms) vs. C _{SS} (µF)				
	No C _{SS}	0.047µF	0.1µF	0.47µF	1.0µF
5	1	29	55	260	500
7.5		18	27	83	162
9		6	10	47	78

Note: Soft-start times are ±35%. C₁ is the soft-start capacitor (C_{SS}); the output capacitor (C_{OUT}) = 33µF; I_{LOAD} = 75mA.

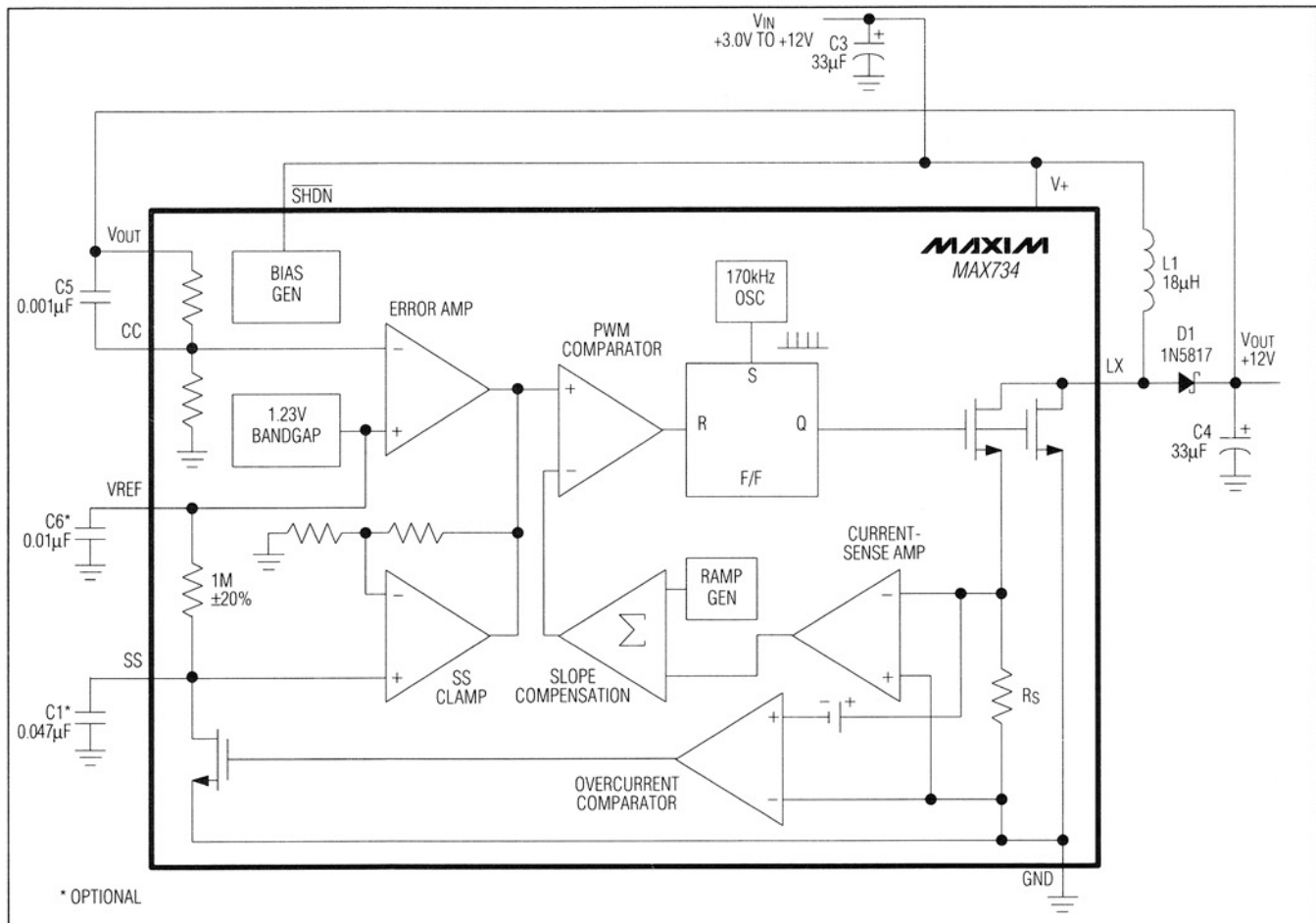

Figure 2. Detailed Block Diagram with External Components

+12V, 120mA Flash Memory Programming Supply

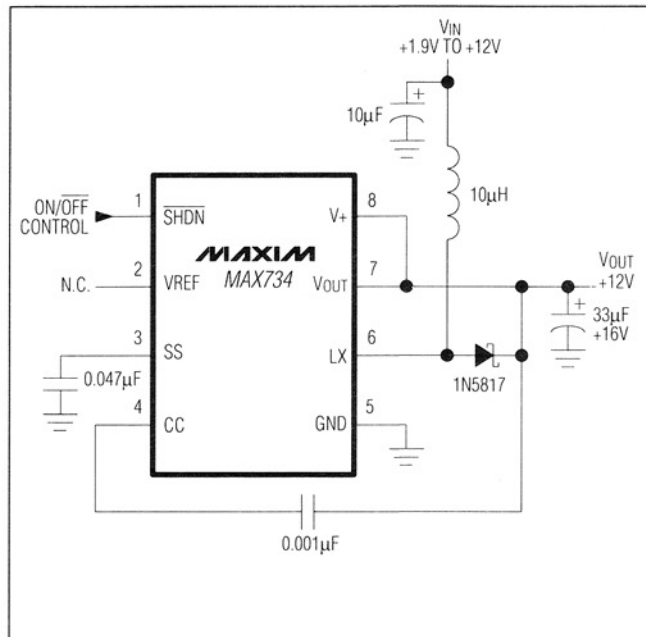

Figure 3. Bootstrap Operation

Detailed Description

The MAX734 switch-mode regulator uses a current-mode pulse-width modulation (PWM) controller in a simple boost regulator circuit to convert +5V to +12V, as shown in Figure 1. The current-mode PWM architecture provides cycle-by-cycle current limiting and excellent line- and load-transient response characteristics.

Operating Principle

The controller consists of two feedback loops: an inner (current) loop that monitors the switch current via the current-sense resistor (R_S) and amplifier; and an outer (voltage) loop that monitors the output voltage via the error amplifier (Figure 2). The inner loop performs cycle-by-cycle current limiting, truncating the power transistor on-time when the switch current reaches a predetermined threshold. This threshold is determined by the outer loop. For example, a sagging output voltage produces an error signal that raises the threshold, allowing the circuit to store and transfer more energy during each cycle.

Programmable Soft Start

A capacitor connected to the Soft-Start (SS) pin ensures an orderly power-up. The voltage on the charging capacitor slowly raises the clamp on the error-amplifier output voltage, limiting surge currents at power-up by slowly increasing the cycle-by-cycle current-limit threshold.

Soft-start timing is controlled by the value of the SS capacitor. Table 1 lists timing characteristics for selected capacitor values and circuit conditions. Where the circuit is required to start up with no load, for example in flash memory programming supplies, soft start is not required. Omitting C_{SS} provides a minimum output voltage rise time from the shutdown state, improving access time.

The output voltage falls if more than the maximum load current is drawn. The overcurrent comparator trips if the load exceeds approximately 1.5A. An SS cycle is actively initiated when either an external shutdown signal is switched from ground to above +2V, or an overcurrent fault condition triggers an internal transistor to discharge the SS capacitor to ground.

Overcurrent Limiting

When the load current exceeds approximately 1.5A, the output stage is turned off by the inner loop cycle-by-cycle current-limiting action, and the overcurrent comparator signals the control logic to initiate a soft-start cycle. On each clock cycle, the switching MOSFET turns on again and attempts to deliver current until cycle-by-cycle or overcurrent limits are exceeded. Note that the SS capacitor must be at least 0.01µF for overcurrent protection to function properly. The SS period should also be longer than the rise time of the supply voltage to which it is connected.

Shutdown

The MAX734 is held in shutdown mode by keeping \overline{SHDN} at ground. In shutdown, the output power FET is off, but there is still an external path from V_+ to the load via the inductor and diode. The internal reference also turns off, which causes the SS capacitor to discharge. Typical device standby current in shutdown mode is 70µA. When current consumption is critical, \overline{SHDN} can be pulse modulated with frequencies as high as 1kHz. This provides +12V at less than the maximum output current, but allows dramatic reduction in overall power consumption. For normal operation, connect \overline{SHDN} to V_+ . An SS cycle is initiated when the MAX734 comes out of shutdown.

Keep \overline{SHDN} low if V_{IN} rises slowly between 1V and 2V. This prevents excessive current flow, which could stall weak +5V supplies and/or battery chargers. When V_{IN} rises more quickly than the SS voltage, this peaking does not occur.

Internal Reference

The +1.23V bandgap reference supplies up to 100µA at V_{REF} . A 0.01µF bypass capacitor from V_{REF} to GND is recommended when V_{REF} supplies current.

+12V, 120mA Flash Memory Programming Supply

Inductor Selection

An 18 μ H inductor is sufficient for most designs. The important specification is the inductor's incremental saturation current rating, which should be greater than three times the DC load current for 5V inputs and five times the DC load for 3V inputs. For lower-power applications, smaller inductor values may be used. Table 2 lists recommended inductor types and suppliers for various applications. The listed surface-mount inductors' efficiencies are nearly equivalent to those of the larger-sized, through-hole inductors.

Output Filter Capacitor Selection

The primary criterion for selecting the output filter capacitor is low effective series resistance (ESR). The product of the inductor current variation and the ESR of the output capacitor determines the amplitude of the high frequency seen on the output voltage. The capacitor's ESR should be less than 0.25 Ω to keep the output ripple less than 50mV_{p-p} over the entire current range (using an 18 μ H inductor). In addition, the output filter capacitor's ESR should be minimized to maintain AC stability. Table 2 lists some suppliers of low-ESR capacitors.

Other Components

Use a Schottky diode or high-speed silicon rectifier with a continuous current rating of at least 300mA for full-load (120mA) operation. The 1N5817 is a good choice. The compensation capacitor (CCC) value at the CC input is critical because it has been selected to provide the best transient response.

Printed Circuit Layout

Printed circuit board layout is not critical except to ensure quiet operation. A ground plane is recommended. Locate bypass capacitors as close to the device as possible to prevent instability and noise pickup. If the V+ to GND bypass capacitor cannot be placed adjacent to the IC pins, bypass these pins directly with a small ceramic capacitor (e.g. 0.1 μ F). Keep the Schottky diode leads short to prevent fast rise-time pulses in the output. Minimize stray capacitance at the LX pin.

Do not use plug-in plastic proto-boards.

Reducing Operating Supply Current

In normal operation with no load, the MAX734 draws about 1.2mA. At full load, this supply current contributes only slightly to inefficiency, but when operating at very light loads, e.g. a few milliamps, it begins to dominate the efficiency calculations. In these circumstances, the SHDN pin can be toggled with a logic signal to reduce the chip's supply current to about 500 μ A. The toggle signal required depends on the load demanded, but a typical application would use a 25% duty cycle at 1kHz.

Bootstrapped Output Circuit

If additional output current is required, the bootstrapped circuit (Figure 3) can be used. This circuit operates on the +12V that it creates (bootstrapped) and produces more output current than the non-bootstrapped circuit with input voltages under +6V. The no-load quiescent current (SHDN = HI) is greater than the normal circuit, but it is unchanged in shutdown mode. See the *Typical Operating Characteristics*.

Chip Topography

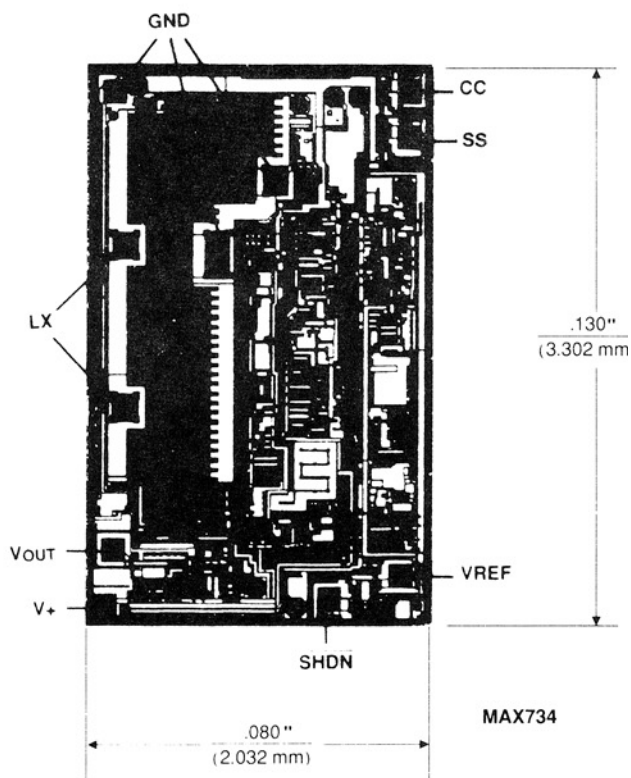

NOTE: SUBSTRATE CONNECTED TO V+;
TRANSISTOR COUNT: 222.

MAX734 Evaluation Kit

EV Kit General Description

The MAX734 evaluation kit is a 12V-output, step-up, switch-mode converter. It delivers a guaranteed 120mA output current with input voltages as low as 4.75V. It is intended for use as a 12V flash memory programming supply. The kit is assembled using the MAX734CSA 8-pin SO and surface-mounted passive components.

The MAX734 evaluation kit has a conversion efficiency of 85% with a low quiescent supply current of 1.2mA. The MAX734 supply current will reduce to less than 100µA when the shutdown control is activated.

The MAX734 uses current-mode pulse-width modulation (PWM) control to provide precise output regulation and low subharmonic ripple noise. A fixed 170kHz oscillator frequency facilitates ripple filtering with the use of smaller external capacitors.

Ordering Information

PART	TEMP. RANGE	BOARD TYPE
MAX734EVKIT-SO	0°C to +70°C	Surface-Mount

Suggested Test Procedure

Place the shunt across pins 1 and 2 of J1. This connects the SHDN pin to VIN for normal operation.

Connect a 5V power supply across the VIN and ground terminals on the evaluation kit printed circuit board. Do not apply power until all connections are complete.

Turn on the supply and measure the output voltage. It will be between 11.52V and 12.48V.

Moving the shunt on J1 to pins 2 and 3 (SHDN to ground) causes the output voltage to drop to 0.3V (a Schottky diode drop) below VIN.

The turn-on time for the MAX734 is controlled by the capacitance on the soft-start pin (SS). C3 is connected to the pin but is not connected to ground. Placing a wire across the pads on J2 connects C3 and changes the start-up time from 1ms to 2.5ms.

Component List

DESIGNATION	QTY	DESCRIPTION	MANUFACTURER
C1, C5	2	33µF 16V low-ESR tantalum capacitor	Sprague 595D336X9016A7 or Matsuo 267M 1602 336 M
C2	1	0.1µF ceramic 1206 SMD chip capacitors	
C3	1	0.01µF ceramic 1206 SMD chip capacitors	
C4	1	0.001µF ceramic 1206 SMD chip capacitors	
D1	1	1N5817 diode	Philips PRL15817 or Nihon EC15QS02L
L1	1	18 µH SMT inductor	Sumida CD54-180
U1	1	MAX734CSA	
None	1	MAX734 data sheet	
None	1	printed circuit board	

Surface Mount Low-ESR Tantalum Capacitors.

Matsuo	(714) 969-2491	267M series
Sprague	(603) 224-1961	595D series

Through-Hole Low-ESR Electrolytic Capacitors.

Nichicon	(708) 843-7500	PL series
United Chemi-Con	(708) 696-2000	LXF series

Ceramic Capacitors

Murata-Erie	(404) 436-1300
-------------	----------------

Diodes

Nihon Inter Electronics	(805) 867-2555
Philips	(401) 762-3800

MAX734 Evaluation Kit

Input Voltage Range

The maximum input voltage for the evaluation kit circuit is restricted to 7V (rather than 9V stated in the MAX734 data sheet) because of inductor value choice. AC instability due to high peak currents will result if this circuit is operated above 7V supply at heavy loads. For a wider input range, increase the inductor value to the 22 μ H to 47 μ H range. If the circuit is operated in continuous-conduction mode, with both high load current and high inductor value (47 μ H), it will require much larger filter capacitors, plus soft-start and reference bypass capacitors to achieve low-noise operation. Continuous-conduction mode allows for lower noise, somewhat greater load-current capability, and better efficiency at the expense of component size and complexity.

Table 3. Troubleshooting Chart

SYMPTOM	POSSIBLE CAUSE
Output collapses when load is applied	<ol style="list-style-type: none"> SHDN is floating. Input supply cannot support demand. Use 500mA 5V source. Load too heavy; reduce to 120mA or less.
Excessive output noise or spikes	<ol style="list-style-type: none"> Scope ground lead is picking up radiated EMI; shorten it. Filter capacitor has high inductance. Add a filter consisting of a 0.5Ω series resistor and a 0.1μF capacitor to the output. SHDN is floating.
Input supply has noise, or spike on start-up	<ol style="list-style-type: none"> Inadequate input filtering; increase C1 value/reduce ESR or add a series inductor. Needs soft-start. Add a 47nF SS capacitor.

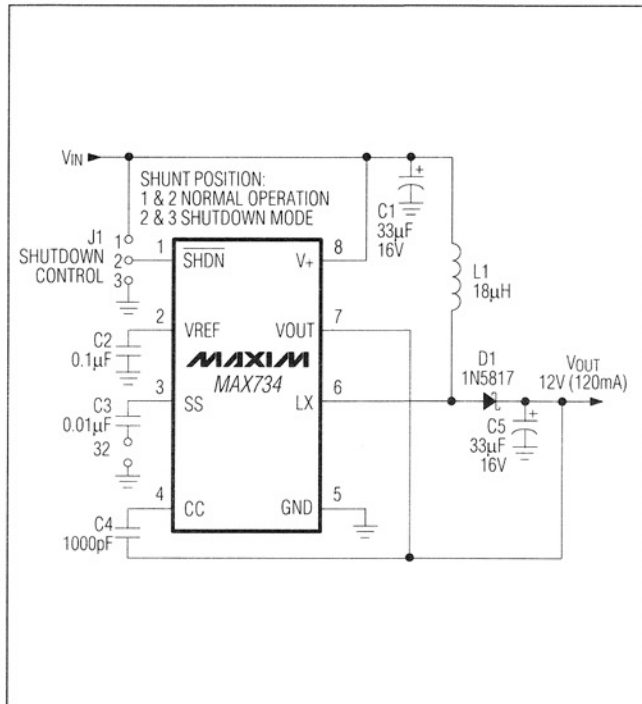

Figure 4. MAX734 EV Kit Schematic Diagram

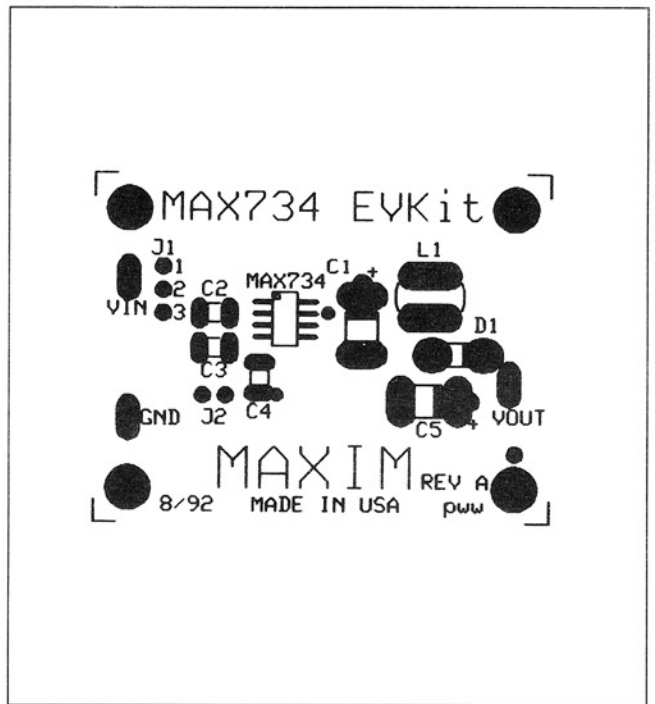

Figure 5. Component Placement Diagram (1x Scale)

MAX734 Evaluation Kit

MAX734 EV Kit

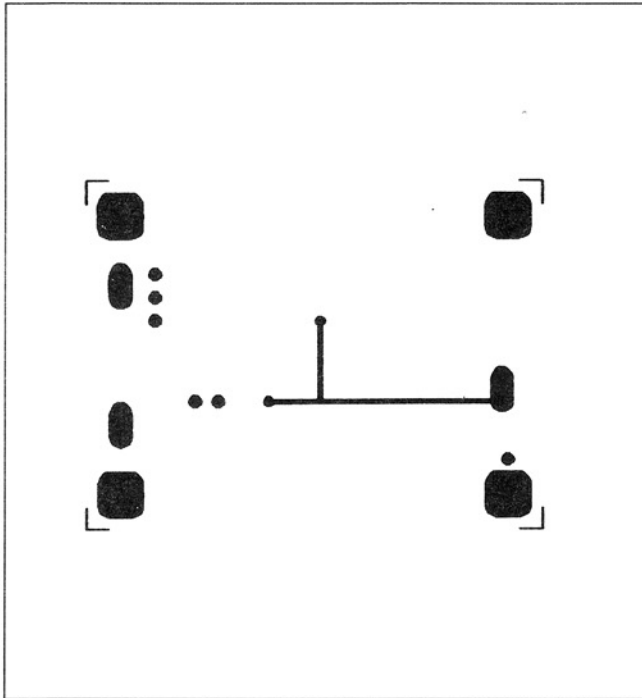

Figure 6a. Printed Circuit Layout (1x Scale, Component Layer, Side View)

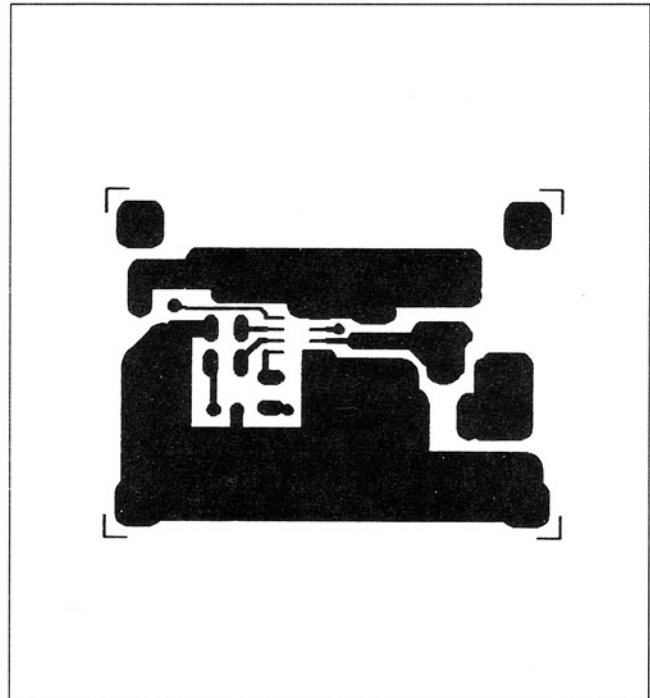

Figure 6b. Printed Circuit Layout (1x Scale, Bottom Layer, Component Side View)

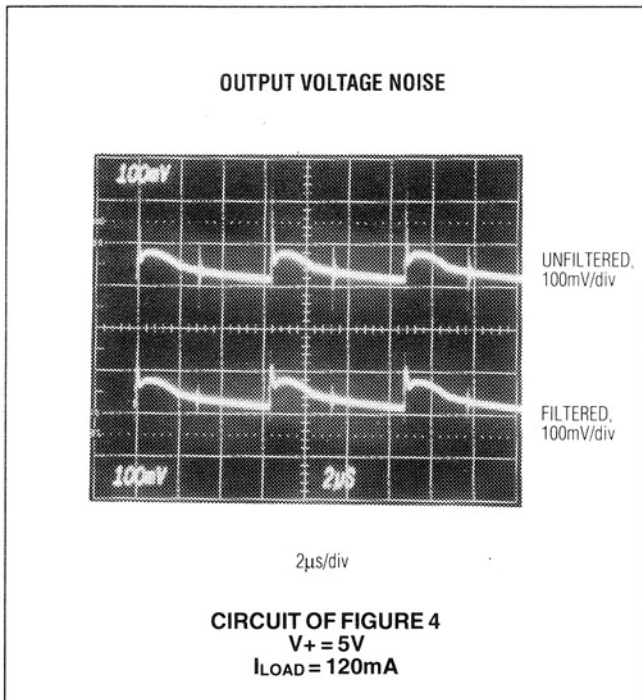

Figure 7. Output Voltage Noise — Unfiltered and Filtered

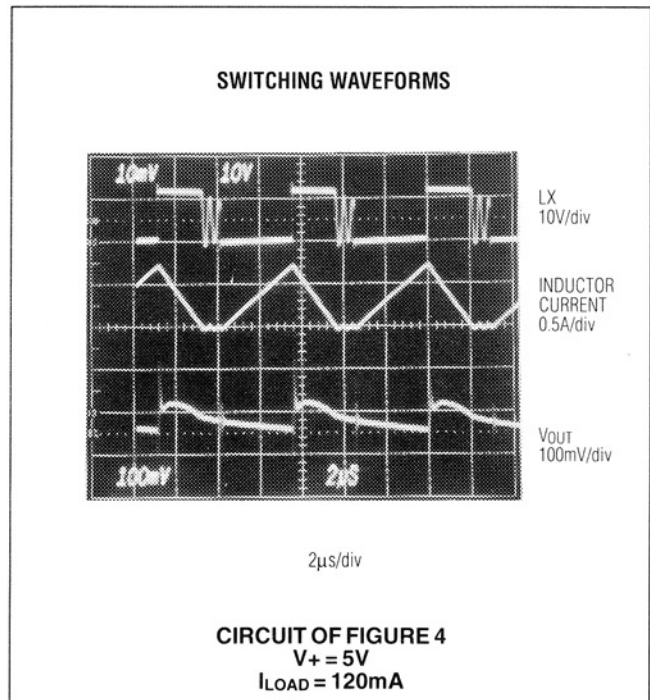

Figure 8. MAX734 Switching Waveforms

MAX734 Evaluation Kit

Flash EEPROM Programmer Applications Information

These application notes give a general description of the VPP programming process and VPP requirements, followed by a "cookbook" collection of flash memory power-supply circuits. These notes are not specific to the MAX734; instead, they employ a number of different IC and discrete solutions.

The seemingly trivial requirement of a +12V DC supply with on/off control leads to some odd and interesting solutions. Four such circuits will be discussed: a 5V-to-12V switch-mode supply for mainstream applications, a linear regulator approach for applications offering higher levels of raw DC voltage, a charge-pump voltage booster that needs no inductors, and four different switching regulators for notebook and palmtop computers and other battery-powered systems.

Flash Memory Programming Power, Vpp

VPP is a label for the 12V DC input terminal on flash memory ICs. Proper operation of the IC restricts this voltage to a narrow window, sandwiched between the conditions of overvoltage — with instant self-destruction — and undervoltage — which can cause faulty programming due to insufficient charge transfer. Consequently, the 5% tolerances on the data sheet are essential specifications.

Flash memory behaves as a primarily capacitive load, with the result that write or erase operations cause a fast-rising current spike ($t_r < 20\text{ns}$) at the VPP pin (Figure 9). Good local bypassing is a must, because the spikes usually exceed the data sheet specs for DC IPP by a wide margin.

A question that may arise is why, if the flash EEPROM load is mostly capacitive, can't the DC load requirements on the power supply be relaxed in favor of adding high-energy filter capacitors to supply the capacitive load spike? The answer lies in the EEPROM's erase cycle. When the cycle begins, an internal switching transistor connects 12V to the source terminals of all transistors in the memory cell array, and the gates of each of the single-transistor memory cells are grounded. Fowler-Nordheim tunneling then erases all bits in the array simultaneously.

The grounded gates cause a breakdown of the gate dielectric, which allows an unwanted flow of DC current (15mA typical, 30mA worst-case for most flash devices). Erase cycles last at least ten milliseconds, so to hold the output-ripple amplitude below 200mV the hold-up capacitor must be 150,000 μF — an unreasonably large value. Therefore, the power supply must be inherently capable of delivering the worst-case DC IPP current.

Flash Memory Ipp Requirements: 30mA, 60mA, 120mA

Flash memory DC-DC applications with VPP supplies involving DC-DC conversion can be sorted by load current or by input voltage. First, the load current considerations:

In designing a flash memory power supply, the first variable to consider is the number of flash devices to be programmed at one time, because that number determines the maximum load current. Supplies, therefore, are commonly specified in multiples of 30mA — the worst-case IPP current drawn by a typical byte-wide flash EEPROM chip during its erase cycle. This current is nearly independent of the memory size, even for experimental 8- and 16-Mbit devices.

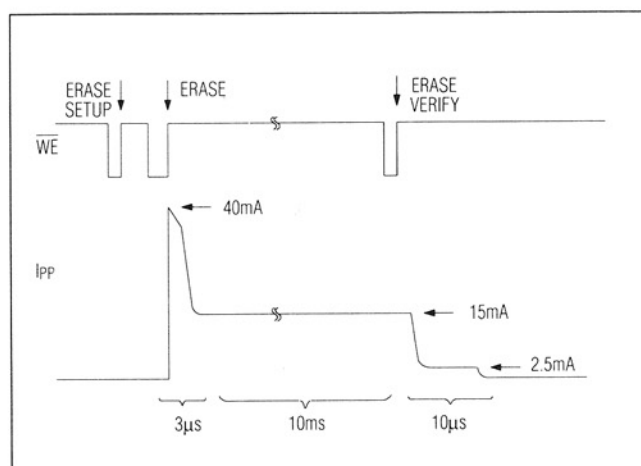

Figure 9. Flash Memory Ipp Input Current Waveforms. On the erase command, Ipp supply current of a 2-Meg Intel 28F020 spikes sharply to 35mA or 45mA, then settles to 15mA steady-state for the duration of the erase cycle. Erase verify consumes only 2.5mA.

Common current requirements for flash EEPROM supplies:

- 30mA:** Update applications for embedded control firmware are not usually speed-critical because reprogramming might occur only once per year (Figure 10). The current needed often defaults to that necessary for programming one device at a time (30mA). Some of these applications require 60mA or even more, if only for the convenience of programming 16 bits at a time.
- 60mA:** In 16-bit systems where write/erase times are important, a 60mA spec allows two byte-wide devices to be programmed simultaneously in word-wide mode (Figure 11). The PCMCIA PC memory card for palmtop computers is one example.

MAX734 Evaluation Kit

120mA: Solid-state "disc drives" made with flash EEPROMs may become common in notebook computers over the next two or three years. To achieve quick access, the chips are organized into two separate banks, each 16 bits wide (Figure 12). While one bank is being programmed the other can be erased. This arrangement doubles the supply-current requirement to 120mA.

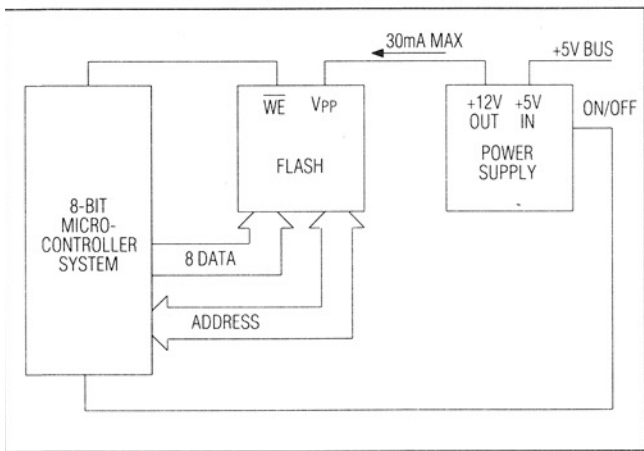

Figure 10. Typical Firmware Update Application ($I_{PP} = 30\text{mA}$). Typical application for 30mA: Add a 5V-to-12V converter to an 8-bit industrial control system. Maximum load current is 30mA. Efficiency is not critical, but physical size and simplicity are important.

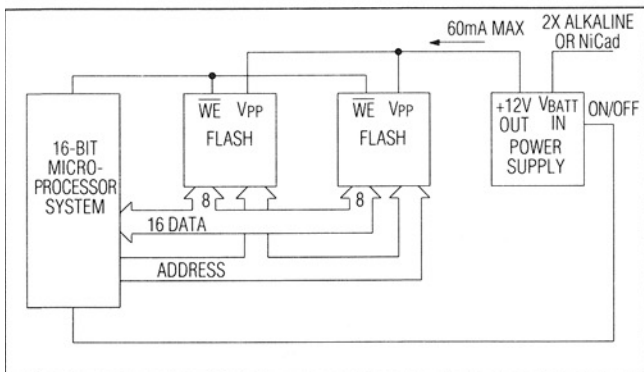

Figure 11. Mass-Storage 1- Palmtop Computer ($I_{PP} = 60\text{mA}$). Typical application for 60mA: Generate 12V from a low-voltage battery pack (often two series NiCad or alkaline cells) for a 16-bit system. Maximum load current is 60mA. Efficiency and standby supply currents are important.

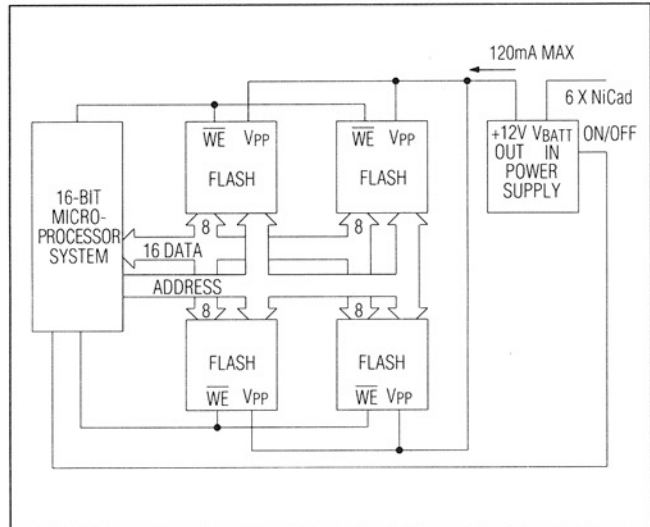

Figure 12. Mass-Storage 2- Notebook/Laptop Computer ($I_{PP} = 120\text{mA}$). Typical application for 120mA: Generate 12V from a medium-voltage battery pack (often six to ten series NiCad cells) for two banks of flash memory in a 16-bit system. Maximum load current is 120mA. Efficiency and standby currents are important.

Overvoltage Considerations

Check your designs for spikes and overshoot because Vpp transients exceeding 13V can destroy flash EEPROMs. Three conditions are likely to cause accidental overvoltage:

- Start-up overshoot
- Load-transient overshoot
- Excessive inductance in the output trace

In a switch-mode power supply (SMPS), start-up overshoot is related to the compensation for loop stability. Excessive compensation can result in large overshoot on power-up, so designs with slow, ultra-stable feedback loops tend to exhibit overshoot. Often, implementing the soft-start function included in some SMPS ICs can reduce this problem, improve overshoot, and reduce supply current transients on power-up. Check the Vpp waveform for power-up overshoot using a storage oscilloscope (Figure 13).

Flash devices are not sensitive to the sequence in which the +12V Vpp and +5V Vcc supply are first applied, so power-supply sequencing is not important. But when not in use, Vpp should be less than 6.5V to prevent accidental erasures or undesired programming.

MAX734 Evaluation Kit

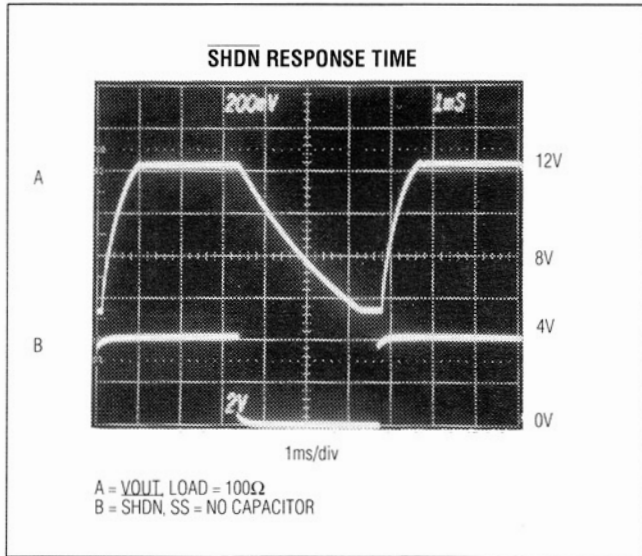

Figure 13. Boost-Regulator Start-Up Waveforms. The output voltage of a properly compensated SMPS will not overshoot when starting up. This photo shows a 5V-to-12V regulator capable of 120mA starting up in less than 2ms with no overshoot.

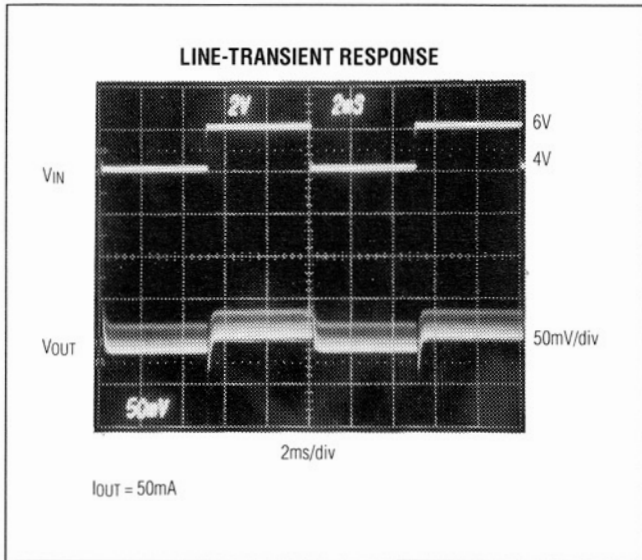

Figure 14. Output Stability vs. Input Swing of 2V (4V to 6V)

Load-transient overshoot in a SMPS or linear regulator is also related to loop compensation. This overshoot is particularly important in flash memory applications, because the rapid change in I_{PP} following an erase command (0 to full load with $t_r < 20\text{ns}$) hits the regulator with a heavy transient. Poorly compensated designs can exhibit overshoot measured in volts instead of millivolts, as some

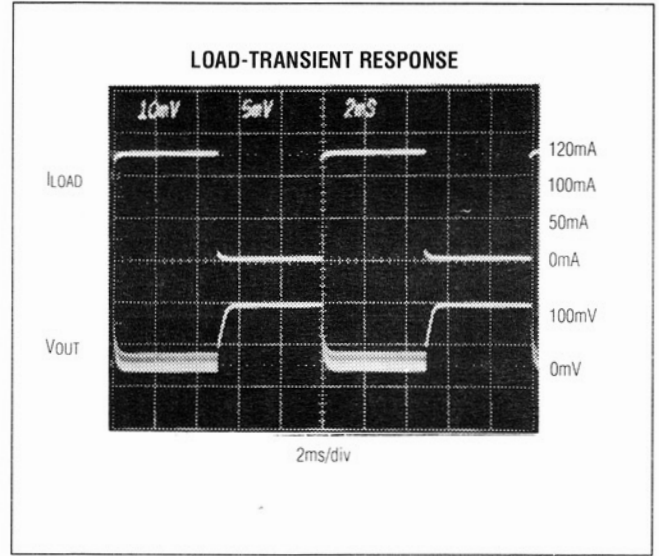

Figure 15. Well-Behaved Load-Transient Response. A well-compensated SMPS exhibits a damped and benign output voltage response when hit with a sharp load current step.

commercial power-supply products demonstrate. Check for problems in the load-transient response using a dummy load and load-pulsing transistor switch (Figure 15).

Excessive inductance in PC board traces can also cause an overvoltage problem, in which I_{PP}'s rapid $\Delta I/\Delta t$ causes a corresponding $\Delta V/\Delta t$ at V_{PP}. The result is destructive overvoltage and ringing. Hash chokes (inductors) can have a similar effect, so the common practice of filtering SMPS switching noise by placing these chokes in series with the 12V output is a bad idea. Filter noise with resistive and capacitive elements only. To check for ringing, monitor V_{PP} and trigger the oscilloscope with the erase command.

Noise, Ripple, and EMI

The V_{PP} input of a flash EEPROM is reasonably noise tolerant in terms of inadvertent erasure and faulty programming. The maximum ripple recommended by manufacturers (typically 200mV) is specified more as a safety margin for overvoltage than as a noise margin.

Two main components characterize the output voltage noise for most switching power supplies: fundamental ripple and high-frequency switching noise. Ripple is created by current pulses at the switching frequency, produced by the inductor or transformer, flowing through the equivalent series resistance (ESR) in the output filter capacitor. In flash V_{PP} supplies, the resulting noise is best minimized by the brute-force technique of specifying low-ESR capacitors.

MAX734 Evaluation Kit

High-frequency components appear as sharp spikes at the switching transitions, and are caused by phenomena such as series inductance in the filter capacitor, diode switching transients, HF ground currents, and radiated EMI picked up by the scope probe's ground lead. You can cure most of these HF noise problems by practicing good PC-board layout, by connecting extra ceramic capacitors in parallel to reduce the filter capacitor inductance, and by shortening the scope probe's ground lead to reduce the phantom noise due to EMI pickup. An extra RC filter consisting of a series resistor of 1Ω or less (higher values cause load regulation problems) and a 0.1μF ceramic capacitor to ground between the power supply and the flash EEPROM (Figures 4 and 7) usually tame even the worst HF switching noise.

Input Voltage Considerations

After load current, input voltage is the main variable when applying DC-DC converters to flash memories. Four major applications may be distinguished according to input voltage:

- 5V only
- Unregulated DC input
- 12V ±10% input
- Batteries

5V-Only Applications

Many microcontroller systems include only a single 5V supply, so to add flash capability you must boost this voltage to 12V. Because all flash memories currently require 5V ±10% in addition to the 12V V_{PP} supply, the applicability of 5V-to-12V DC-DC converters is nearly universal (Figure 16). This circuit is the same as the MAX734 EV kit circuit (Figure 4). This circuit features fixed-frequency, 170kHz operation that allows the use of small inductors and filter components. Combining this advantage with the space-saving SOIC packaging and an elementary boost topology that requires only a simple inductor yields a complete-circuit footprint just over 1/2 square inch.

The MAX734 DC-DC regulator IC used in this circuit contains a current-mode SMPS controller and 2A power MOSFET. The regulator is digitally controlled via its $\overline{\text{SHDN}}$ pin. When low, $\overline{\text{SHDN}}$ disables the device and reduces the IC supply current to 6μA. In this inactive state, the series-DC connection of inductor and rectifier places V_{PP} at the level of V_{IN} minus the forward drop of the rectifier diode.

Because this low level of V_{PP} (approximately 4.7V) cannot program a flash memory device, there is no need for an extra switch transistor that disconnects the output completely. When $\overline{\text{SHDN}}$ goes high, the internal pulse-width

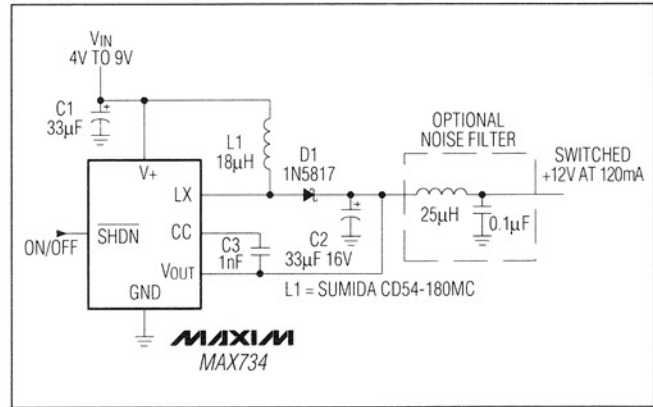

Figure 16. MAX734 Universal 5V-to-12V Solution. 170kHz fixed-frequency operation keeps component sizes small in this basic boost regulator circuit.

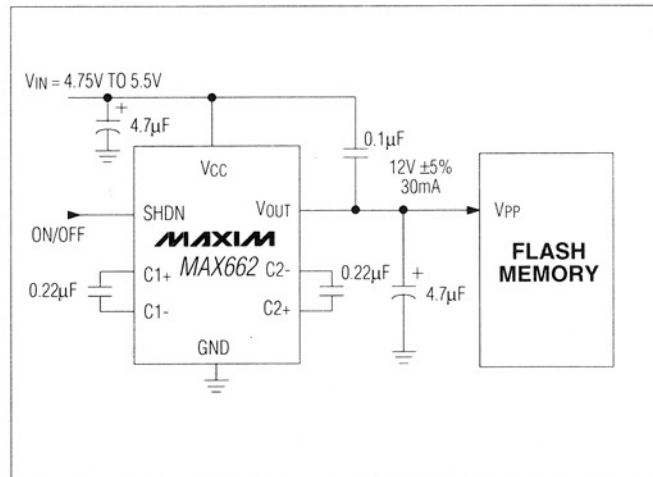

Figure 17. MAX662 Charge-Pump DC-DC (5V-to-12V at 30mA). This charge pump does the 5V-to-12V conversion task without inductors or transformers.

modulator begins switching and drives V_{PP} to 12V. Efficiency is greater than 85% over most of the load range. For 60mA or 30mA applications, efficiency can be increased by a few percent (up to 90%) by increasing the inductor value to 33μH or 47μH.

In most cases you can turn V_{PP} off and on with a logic signal applied to $\overline{\text{SHDN}}$. This method is convenient and simple, and reduces the circuit supply current to about 100μA, which is the current required by the internal resistor feedback divider that sets the output voltage. For examples of other shutdown methods, see the battery-powered circuits that follow.

MAX734 Evaluation Kit

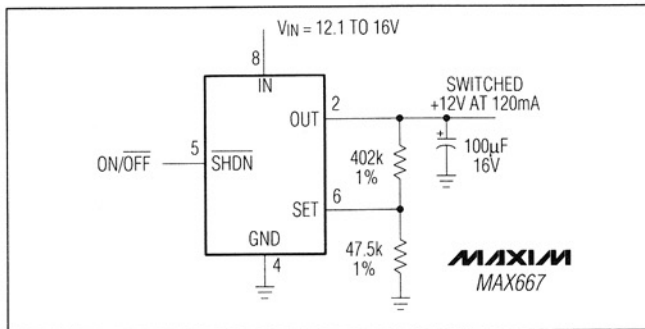

Figure 18. Switched Linear Regulator Supply. A linear regulator provides simple and compact V_{PP} supply for unregulated DC inputs higher than V_{PP} .

For people who absolutely hate inductors and all things magnetic, the MAX662 capacitor-based charge pump provides an excellent alternative to the SMPS approach. The 5V-to-12V charge-pump converter of Figure 17, for example, generates a clean, well-regulated V_{PP} supply that delivers 30mA.

The resulting 12V output is regulated to $\pm 5\%$ at 30mA, guaranteed over the commercial temperature range.

The MAX662's input supply range is 4.75V to 5V. Quiescent supply current is $320\mu\text{A}$ ($70\mu\text{A}$ in logic controlled shutdown).

The circuit of Figure 18 offers a good mix of features for applications in which the maximum unregulated DC voltage is 16.5V or less. The linear regulator IC has a built-in shutdown function, comes in a small 8-lead SOIC package, and allows V_{IN} to sag within 100mV of 12V at full load due to its low-dropout capability. This micropower circuit also provides post-regulation for multi-output power supplies (see the buck regulator with flyback winding in Figure 19).

Operation From 12V $\pm 10\%$ Input

Often encountered is the need to tighten the output tolerance of a supply from, say, $\pm 10\%$ (commonly found in the power supplies for desktop PCs) to $\pm 5\%$. Some engineers, unfortunately, pass this tolerance burden on to their customers by ignoring the $\pm 5\%$ restrictions on V_{PP} . One manufacturer, for example, simply taps the PC's bus directly to obtain power for its add-on flash memory solid-state disc drive card. But if you dig far enough into the specs for the card, you will find a disclaimer stating that one must provide $\pm 2.5\%$ tolerance supplies.

The spec is $\pm 2.5\%$ instead of $\pm 5\%$ to accommodate high IR drops in their high-side V_{PP} switches. This bad engineering is "best-case" instead of "worst-case" design. Better off, but possibly asking for trouble, is the mass-storage tape-drive manufacturer who puts a low-dropout linear regulator on the +12V bus. At least his EEPROMs won't blow up when the 117V AC line surges, but he may suffer slow programming and outright programming failures. Such faults are particularly likely in flash chips that have undergone many write/erase cycles, because the gate-tunneling in these devices has an inherent wear-out mechanism. For firmware update applications, the low-dropout regulator is actually a decent compromise between cost and reliability, since it will almost certainly see only one or two reprogrammings over the lifetime of the product.

It's possible to make a 12V-to-12V converter for tightening the $\pm 10\%$ tolerance on a 12V supply, but a 5V-to-12V step-up approach is more practical. The 12V-to-12V converter must both step up and step down, requiring a flyback transformer, a lossy zener in series with the rectifier, or some other complicated scheme. A boost regulator operating from 5V provides a cleaner solution.

Battery-Powered Circuits

The emerging mass-storage applications for flash memory have escalated the demand for 12V V_{PP} supplies. These applications take various forms. A flash memory programmer for portable battery-operated equipment, for example, is best powered directly from the battery; deriving 12V from the 5V system compounds the efficiency losses. Battery-powered flash supplies need a wider input voltage range (to accommodate the decaying battery voltage) than do their 5V-powered counterparts. Also important in battery-powered systems are efficiency, low quiescent current, and start-up time.

Input range and battery type establish three major applications for battery-powered computers:

Laptop/notebook computers:

- 6V to 15V input range
- 6 to 10 NiCad cells or a 12V lead-acid battery

Portable data-entry terminals and notebook computers:

- 4V to 9V input range
- 4 or 5 NiCad cells or two lithium cells in series

Palmtop computers:

MAX734 Evaluation Kit

A light minimum load should also be maintained on the 12V output to prevent that output from creeping up. Note that returning the secondary winding to 5V rather than to ground allows for fewer transformer windings, and also reduces peak currents in the power MOSFET. The 12V output can be switched on and off with the SHDN input on the MAX667 low-dropout linear regulator.

Boost Regulator With Low-Power Shutdown Mode

Previous circuits (except for the MAX667 linear regulator) have not been micropower in nature, for they still draw 100 μ A or more when in standby mode. To be truly micropower, the supply current should be down at the level of the battery self-leakage current (typically 20 μ A or so). Boost regulators in general are difficult to shut down completely because of the series connection of inductor and rectifier, which forces the output to $V_{IN}-V_{DIODE}$. Even if the load is not drawing current, the regulator's own feedback resistors act as a load.

Figure 18 shows a boost regulator using an external P-channel power MOSFET as a high-side load switch, which enables the standby current to be cut to 6 μ A typ. The MAX734's feedback input (V_{OUT}) is connected to the output side of the load switch, and is therefore disconnected when the circuit is shut down. The MOSFET switch provides an unexpected bonus, in that it can be used as part of an RC filter to eliminate HF switching noise. This filter consists of the on resistance of the switch and a 0.1 μ F ceramic capacitor. The V_{PP} control must be driven by an open-collector or open-drain gate capable of withstanding 12V. Start-up time is less than 2ms.

PCMCIA Memory Card Programmer

In September 1991, a preliminary standard for removable memory cards was adopted by an association of portable computer and memory card manufacturers. Personal Computer Memory Card International Association's (PCMCIA) PC Card release 2.0 sets the V_{PP} power requirements for flash memory cards and other types such as SRAM, DRAM, EPROM, EEPROM, and OTP. Because regular EPROMs require V_{PP} levels of 0V and 5V, the V_{PP} line in a PCMCIA adapter must deliver 0V, 5V, and 12V to accommodate all memory types. This multi-voltage function is also useful for embedded control applications in programming certain boot-block-erase flash EEPROMs.

Like the palmtop computer application, the PCMCIA programmer (Figure 21) powers the inductor directly from the battery in order to avoid compounding efficiency losses through two converters.

Discrete N-channel and P-channel MOSFETs perform the output switching in Figure 21. 0V/5V/12V switching action requires two series N-channel devices in the 5V line because of the body diode between source and drain of commercially available discrete MOSFETs. Without the extra MOSFET, the 12V output would be pulled down to 5V through the body diode when the circuit is programmed to the 12V state.

References

Levy, Markus, "Flash Memory Energy Consumption Characteristics," Intel Application Note May 1991

Intel 1991 Memory Products Databook, Intel publication 210830

PCMCIA PC Card Standard, Release 2.0, September 1991

MAX734 Evaluation Kit

MAX734 EV Kit

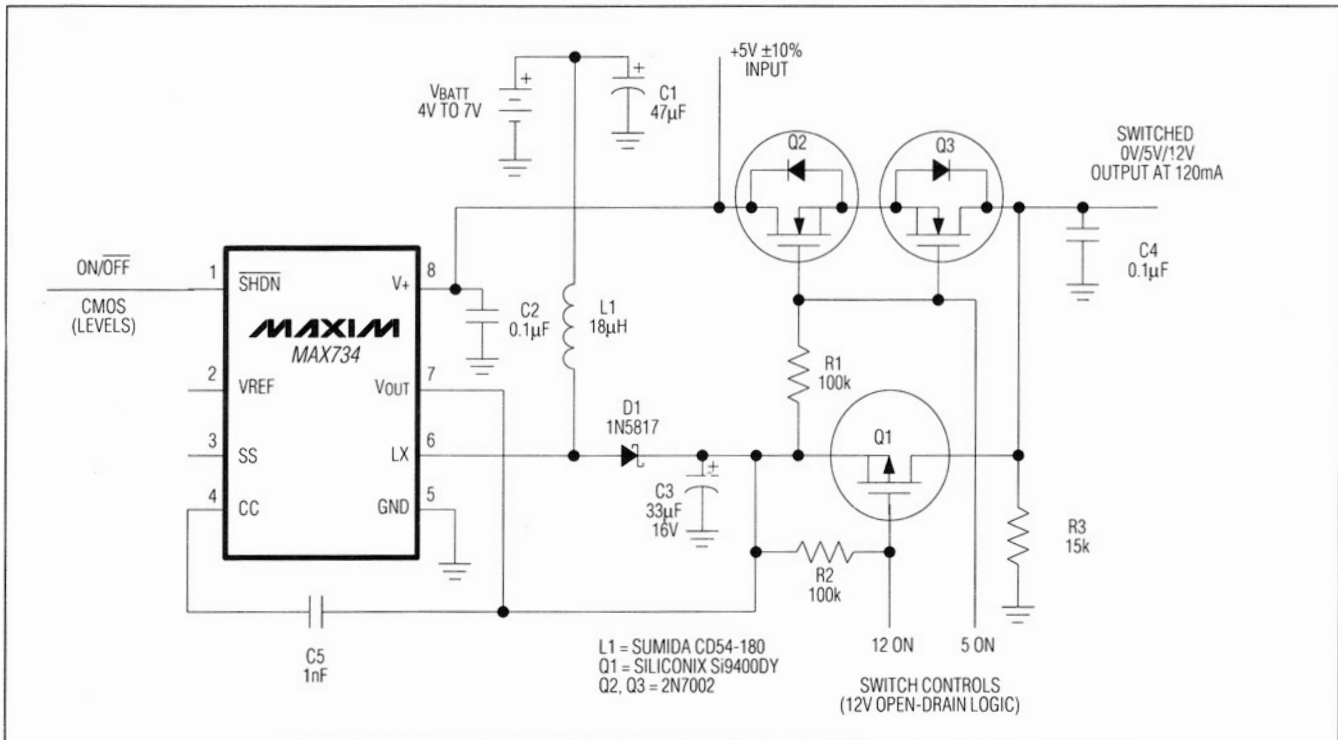

Figure 21. PCMCIA Memory Card Switched 0V/5V/12V Supply. A boost regulator plus a MOSFET switching network provide power to a PCMCIA adapter.

MAX734 Evaluation Kit

Maxim cannot assume responsibility for use of any circuitry other than circuitry entirely embodied in a Maxim product. No circuit patent licenses are implied. Maxim reserves the right to change the circuitry and specifications without notice at any time.

20 _____ **Maxim Integrated Products, 120 San Gabriel Drive, Sunnyvale, CA 94086 (408) 737-7600**

Looking for pricing, stock, or lifecycle information?

Click below to explore more details on WIN SOURCE:

 [View MAX734ESA+](#) on WIN SOURCE

 [Maxim Integrated](#) Information

Optimize Your Supply Chain with WIN SOURCE Solutions

-  Global Sourcing Solution
-  Obsolete Management
-  Cost Control Management
-  Shortage Management
-  Alternative Solution
-  Excess Inventory Management