



**THE DATASHEET OF
MAX797CSE+T**



Step-Down Controllers with Synchronous Rectifier for CPU Power

General Description

The MAX796/MAX797/MAX799 high-performance, step-down DC-DC converters with single or dual outputs provide main CPU power in battery-powered systems. These buck controllers achieve 96% efficiency by using synchronous rectification and Maxim's proprietary Idle Mode™ control scheme to extend battery life at full-load (up to 10A) and no-load outputs. Excellent dynamic response corrects output transients caused by the latest dynamic-clock CPUs within five 300kHz clock cycles. Unique bootstrap circuitry drives inexpensive N-channel MOSFETs, reducing system cost and eliminating the crowbar switching currents found in some PMOS/NMOS switch designs.

The MAX796/MAX799 are specially equipped with a secondary feedback input (SECFB) for transformer-based dual-output applications. This secondary feedback path improves cross-regulation of positive (MAX796) or negative (MAX799) auxiliary outputs.

The MAX797 has a logic-controlled and synchronizable fixed-frequency pulse-width-modulating (PWM) operating mode, which reduces noise and RF interference in sensitive mobile-communications and pen-entry applications. The SKIP override input allows automatic switchover to idle-mode operation (for high-efficiency pulse skipping) at light loads, or forces fixed-frequency mode for lowest noise at all loads.

The MAX796/MAX797/MAX799 are all available in 16-pin DIP and narrow SO packages. See the table below to compare these three converters.

PART	MAIN OUTPUT	SPECIAL FEATURE
MAX796	3.3V/5V or adj	Regulates positive secondary voltage (such as +12V)
MAX797	3.3V/5V or adj	Logic-controlled low-noise mode
MAX799	3.3V/5V or adj	Regulates negative secondary voltage (such as -5V)

Applications

Notebook and Subnotebook Computers
PDAs and Mobile Communicators
Cellular Phones

Idle Mode is a trademark of Maxim Integrated Products.

Features

- ◆ 96% Efficiency
- ◆ 4.5V to 30V Input Range
- ◆ 2.5V to 6V Adjustable Output
- ◆ Preset 3.3V and 5V Outputs (at up to 10A)
- ◆ Multiple Regulated Outputs
- ◆ +5V Linear-Regulator Output
- ◆ Precision 2.505V Reference Output
- ◆ Automatic Bootstrap Circuit
- ◆ 150kHz/300kHz Fixed-Frequency PWM Operation
- ◆ Programmable Soft-Start
- ◆ 375µA Typ Quiescent Current ($V_{IN} = 12V$, $V_{OUT} = 5V$)
- ◆ 1µA Typ Shutdown Current

Ordering Information

PART	TEMP RANGE	PIN-PACKAGE
MAX796CPE	0°C to +70°C	16 Plastic DIP
MAX796CSE	0°C to +70°C	16 Narrow SO
MAX796C/D	0°C to +70°C	Dice*
MAX796EPE	-40°C to +85°C	16 Plastic DIP
MAX796ESE	-40°C to +85°C	16 Narrow SO
MAX796MJE	-55°C to +125°C	16 CERDIP

Ordering Information continued at end of data sheet.

*Contact factory for dice specifications.

Pin Configuration

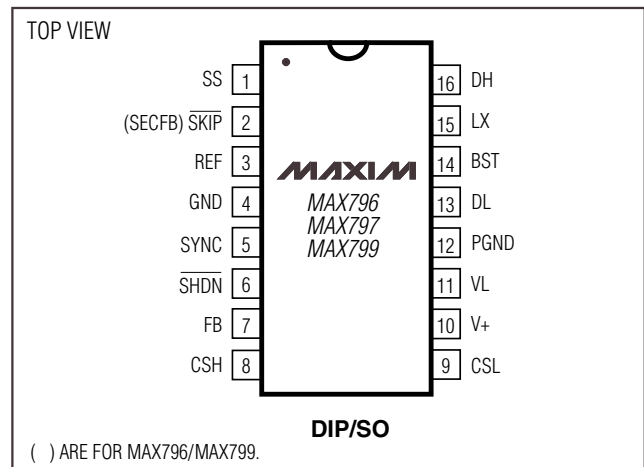

Step-Down Controllers with Synchronous Rectifier for CPU Power

ABSOLUTE MAXIMUM RATINGS

V+ to GND	-0.3V, +36V	VL Output Current	50mA
GND to PGND	±2V	Continuous Power Dissipation (TA = +70°C)	
VL to GND	-0.3V, +7V	SO (derate 8.70mW/°C above +70°C)	696mW
BST to GND	-0.3V, +36V	Plastic DIP (derate 10.53mW/°C above +70°C)	842mW
DH to LX	-0.3V, BST + 0.3V	CERDIP (derate 10.00mW/°C above +70°C)	800mW
LX to BST	-7V, +0.3V	Operating Temperature Ranges	
SHDN to GND	-0.3V, +36V	MAX79_C_	0°C to +70°C
SYNC, SS, REF, FB, SECFB, SKIP, DL to GND	-0.3V, VL + 0.3V	MAX79_E_	-40°C to +85°C
CSH, CSL to GND	-0.3V, +7V	MAX79_MJE	-55°C to +125°C
VL Short Circuit to GND	Momentary	Storage Temperature Range	-65°C to +160°C
REF Short Circuit to GND	Continuous	Lead Temperature (soldering, 10s)	+300

Stresses beyond those listed under "Absolute Maximum Ratings" may cause permanent damage to the device. These are stress ratings only, and functional operation of the device at these or any other conditions beyond those indicated in the operational sections of the specifications is not implied. Exposure to absolute maximum rating conditions for extended periods may affect device reliability.

ELECTRICAL CHARACTERISTICS

(V+ = 15V, GND = PGND = 0V, I_{VL} = I_{REF} = 0A, TA = 0°C to +70°C for MAX79_C, TA = 0°C to +85°C for MAX79_E, TA = -55°C to +125°C for MAX79_M, unless otherwise noted.)

PARAMETER	CONDITIONS	MIN	TYP	MAX	UNITS
+3.3V AND +5V STEP-DOWN CONTROLLERS					
Input Supply Range	MAX79_C	4.5		30	V
	MAX79_E/M	5.0		30	
5V Output Voltage (CSL)	0mV < (CSH-CSL) < 80mV, FB = VL, 6V < V+ < 30V, includes line and load regulation	4.85	5.10	5.25	V
3.3V Output Voltage (CSL)	0mV < (CSH-CSL) < 80mV, FB = 0V, 4.5V < V+ < 30V, includes line and load regulation	3.20	3.35	3.46	V
Nominal Adjustable Output Voltage Range	External resistor divider	REF		6	V
Feedback Voltage	(CSH-CSL) = 0V	2.43	2.505	2.57	V
Load Regulation	0mV < (CSH-CSL) < 80mV		2.5		%
	25mV < (CSH-CSL) < 80mV		1.5		
Line Regulation	6V < V+ < 30V		0.04	0.06	%/V
Current-Limit Voltage	CSH-CSL, positive	80	100	120	mV
	CSH-CSL, negative	-50	-100	-160	
SS Source Current		2.5	4.0	6.5	µA
SS Fault Sink Current		2.0			mA
FLYBACK/PWM CONTROLLER					
SECFB Regulation Setpoint	Falling edge, hysteresis = 15mV (MAX796)	2.45	2.505	2.55	V
	Falling edge, hysteresis = 20mV (MAX799)	-0.05	0	0.05	
INTERNAL REGULATOR AND REFERENCE					
VL Output Voltage	SHDN = 2V, 0mA < I _{VL} < 25mA, 5.5V < V+ < 30V	4.7		5.3	V
VL Fault Lockout Voltage	Rising edge, hysteresis = 15mV	3.8		4.1	V
VL/CSL Switchover Voltage	Rising edge, hysteresis = 25mV	4.2		4.7	V

Step-Down Controllers with Synchronous Rectifier for CPU Power

MAX796/MAX797/MAX799

ELECTRICAL CHARACTERISTICS (continued)

(V+ = 15V, GND = PGND = 0V, I_{VL} = I_{REF} = 0A, T_A = 0°C to +70°C for MAX79_C, T_A = 0°C to +85°C for MAX79_E, T_A = -55°C to +125°C for MAX79_M, unless otherwise noted.)

PARAMETER	CONDITIONS	MIN	TYP	MAX	UNITS	
Reference Output Voltage	No external load (Note 1)	MAX79_C	2.46	2.505	2.54	V
		MAX79_E/M	2.45		2.55	
Reference Fault Lockout Voltage	Falling edge	1.8		2.3	V	
Reference Load Regulation	0μA < I _{REF} < 100μA			50	mV	
CSL Shutdown Leakage Current	$\overline{\text{SHDN}} = 0\text{V}$, CSL = 6V, V+ = 0V or 30V, VL = 0V		0.1	1	μA	
V+ Shutdown Current	$\overline{\text{SHDN}} = 0\text{V}$, V+ = 30V, CSL = 0V or 6V	MAX79_C	1	3	μA	
		MAX79_E/M	1	5		
V+ Off-State Leakage Current	FB = CSH = CSL = 6V, VL switched over to CSL	MAX79_C	1	3	μA	
		MAX79_E/M	1	5		
Dropout Power Consumption	V+ = 4V, CSL = 0V (Note 2)		4	8	mW	
Quiescent Power Consumption	CSH = CSL = 6V		4.8	6.6	mW	
OSCILLATOR AND INPUTS/OUTPUTS						
Oscillator Frequency	SYNC = REF	270	300	330	kHz	
	SYNC = 0V or 5V	125	150	175		
SYNC High Pulse Width		200			ns	
SYNC Low Pulse Width		200			ns	
SYNC Rise/Fall Time	Guaranteed by design			200	ns	
Oscillator Sync Range		190		340	kHz	
Maximum Duty Cycle	SYNC = REF	89	91		%	
	SYNC = 0V or 5V	93	96			
Input High Voltage	SYNC	VL - 0.5			V	
	$\overline{\text{SHDN}}$, $\overline{\text{SKIP}}$	2.0				
Input Low Voltage	SYNC	0.8			V	
	$\overline{\text{SHDN}}$, $\overline{\text{SKIP}}$	0.5				
Input Current	$\overline{\text{SHDN}}$, 0V or 30V	2.0			μA	
	SECFB, 0V or 4V	0.1				
	SYNC, $\overline{\text{SKIP}}$	1.0				
	CSH, CSL, CSH = CSL = 6V, device not shut down	50				
	FB, FB = REF	±100				
DL Sink/Source Current	DL forced to 2V		1		A	
DH Sink/Source Current	DH forced to 2V, BST-LX = 4.5V		1		A	
DL On-Resistance	High or low			7	Ω	
DH On-Resistance	High or low, BST-LX = 4.5V			7	Ω	

Note 1: Since the reference uses VL as its supply, V+ line-regulation error is insignificant.

Note 2: At very low input voltages, quiescent supply current may increase due to excess PNP base current in the VL linear regulator. This occurs only if V+ falls below the preset VL regulation point (5V nominal). See the Quiescent Supply Current vs. Supply Voltage graph in the *Typical Operating Characteristics*.

Step-Down Controllers with Synchronous Rectifier for CPU Power

ELECTRICAL CHARACTERISTICS (continued)

(V₊ = 15V, GND = PGND = 0V, I_{VL} = I_{REF} = 0A, T_A = -40°C to +85°C for MAX79_E, unless otherwise noted.) (Note 3)

PARAMETER	CONDITIONS	MIN	TYP	MAX	UNITS
+3.3V and +5V STEP-DOWN CONTROLLERS					
Input Supply Range		5.0		30	V
5V Output Voltage (CSL)	0mV < (CSH - CSL) < 80mV, FB = VL, 6V < V ₊ < 30V, includes line and load regulation	4.70	5.10	5.40	V
3.3V Output Voltage (CSL)	0mV < (CSH - CSL) < 80mV, FB = VL, 4.5V < V ₊ < 30V, includes line and load regulation	3.10	3.35	3.56	V
Nominal Adjustable Output Voltage Range	External resistor divider	REF		6.0	V
Feedback Voltage	(CSH-CSL) = 0V	2.40		2.60	V
Line Regulation	6V < V ₊ < 30V		0.04	0.06	%/V
Current-Limit Voltage	CSH - CSL, positive	70		130	mV
	CSH - CSL, negative	-40	-100	-160	
FLYBACK/PWM CONTROLLER					
SECFB Regulation Setpoint	Falling edge, hysteresis = 15mV (MAX796)	2.40		2.60	V
	Falling edge, hysteresis = 20mV (MAX799)	-0.08		0.08	
INTERNAL REGULATOR AND REFERENCE					
VL Output Voltage	$\overline{\text{SHDN}} = 2\text{V}$, 0mA < I _{VL} < 25mA, 5.5V < V ₊ < 30V	4.7		5.3	V
VL Fault Lockout Voltage	Rising edge, hysteresis = 15mV	3.75		4.05	V
VL/CSL Switchover Voltage	Rising edge, hysteresis = 25mV	4.2		4.7	V
Reference Output Voltage	No external load (Note 1)	2.43	2.505	2.57	V
Reference Load Regulation	0μA < I _{REF} < 100μA			50	mV
V ₊ Shutdown Current	$\overline{\text{SHDN}} = 0\text{V}$, V ₊ = 30V, CSL = 0V or 6V		1	10	μA
V ₊ Off-State Leakage Current	FB = CSH = CSL = 6V, VL switched over to CSL		1	10	μA
Quiescent Power Consumption			4.8	8.4	mW
OSCILLATOR AND INPUTS/OUTPUTS					
Oscillator Frequency	SYNC = REF	250	300	350	kHz
	SYNC = 0V or 5V	120	150	180	
SYNC High Pulse Width		250			ns
SYNC Low Pulse Width		250			ns
Oscillator Sync Range		210		320	kHz
Maximum Duty Cycle	SYNC = REF	89	91		%
	SYNC = 0V or 5V	93	96		
DL On-Resistance	High or low			7	Ω
DH On-Resistance	High or low, BST - LX = 4.5V			7	Ω

Note 3: All -40°C to +85°C specifications above are guaranteed by design.

Step-Down Controllers with Synchronous Rectifier for CPU Power

Typical Operating Circuits

MAX796/MAX797/MAX799

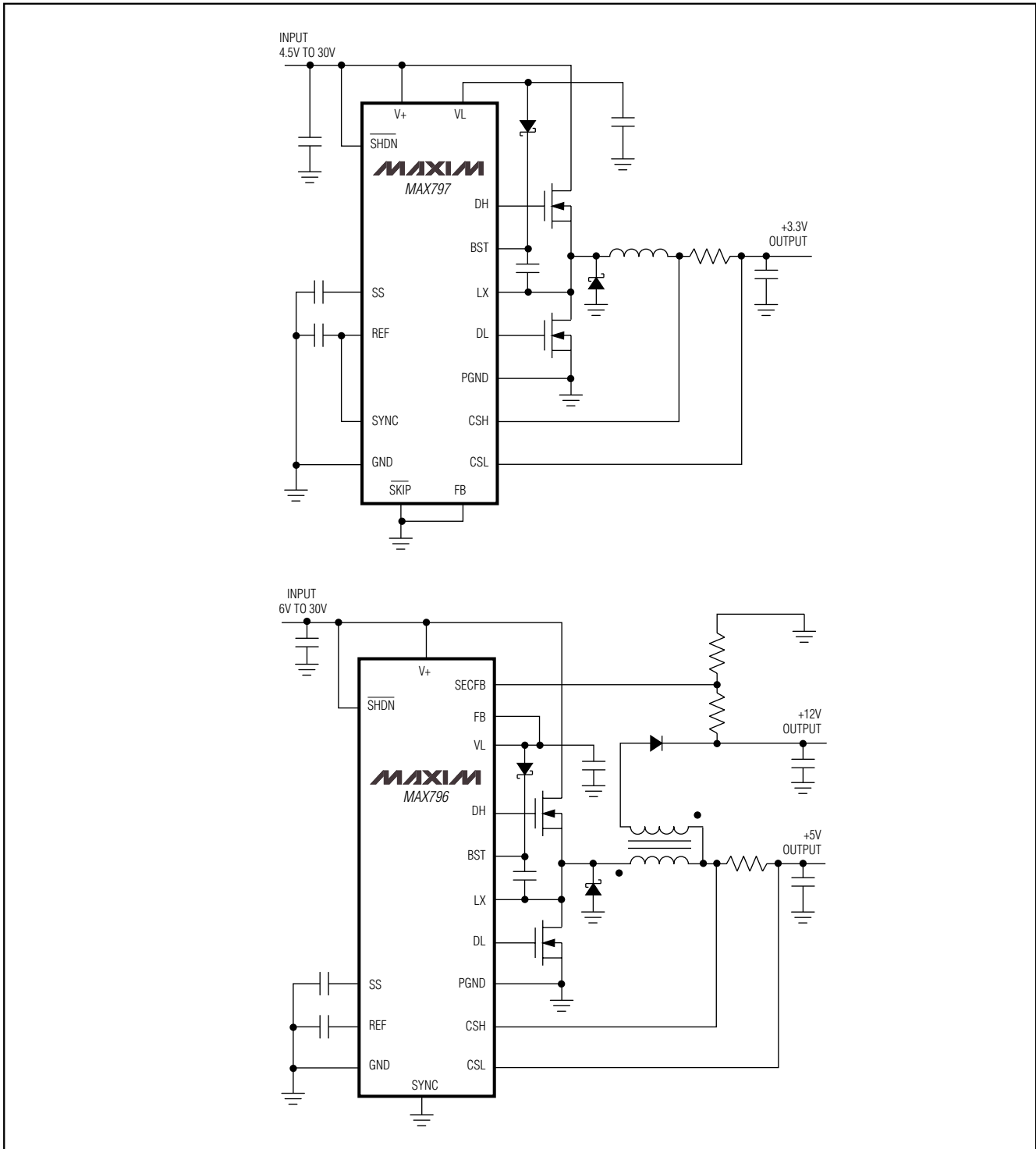

Step-Down Controllers with Synchronous Rectifier for CPU Power

Typical Operating Circuits (continued)

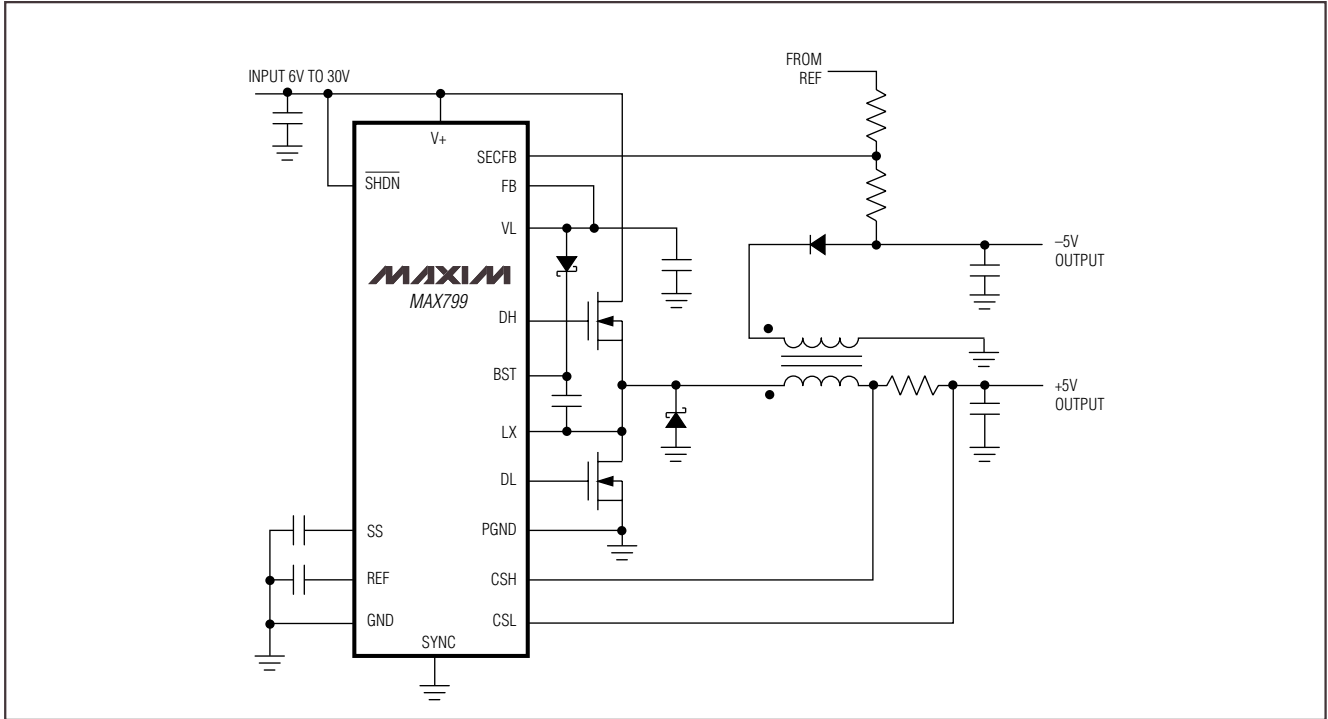

Typical Operating Characteristics

($T_A = +25^\circ\text{C}$, unless otherwise noted.)

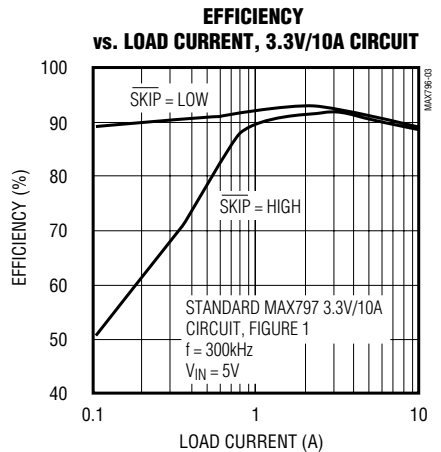
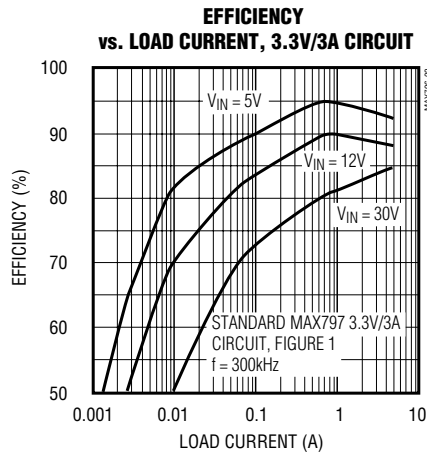
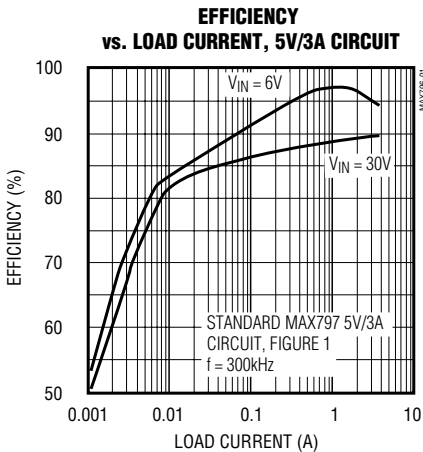

Step-Down Controllers with Synchronous Rectifier for CPU Power

Typical Operating Characteristics (continued)

($T_A = +25^\circ\text{C}$, unless otherwise noted.)

MAX796/MAX797/MAX799

QUIESCENT SUPPLY CURRENT vs. SUPPLY VOLTAGE, 5V/3A CIRCUIT IN IDLE MODE

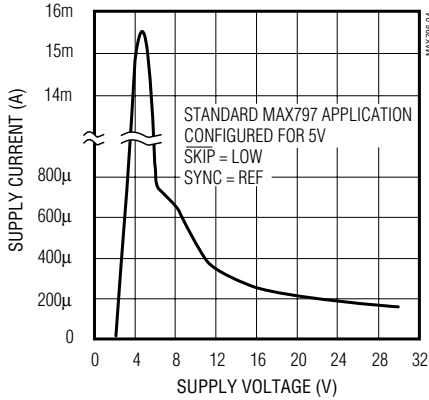

QUIESCENT SUPPLY CURRENT vs. SUPPLY VOLTAGE, 3.3V/3A CIRCUIT IN IDLE MODE

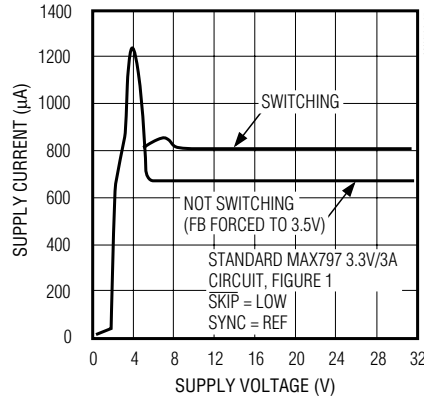

QUIESCENT SUPPLY CURRENT vs. SUPPLY VOLTAGE, LOW-NOISE MODE

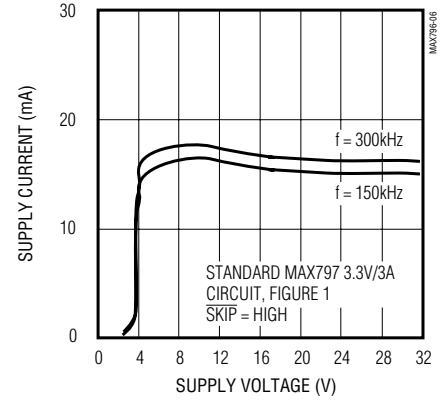

SHUTDOWN SUPPLY CURRENT vs. SUPPLY VOLTAGE

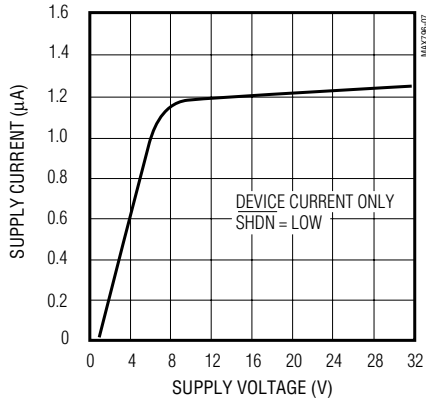

DROPOUT VOLTAGE vs. LOAD CURRENT

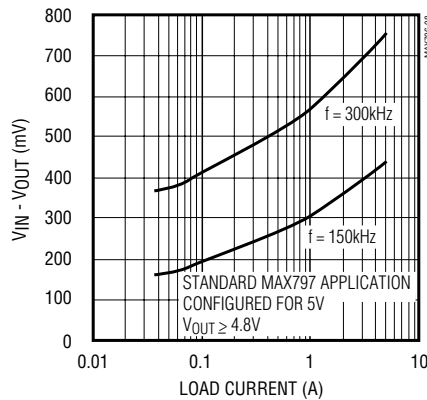

REF LOAD-REGULATION ERROR vs. LOAD CURRENT

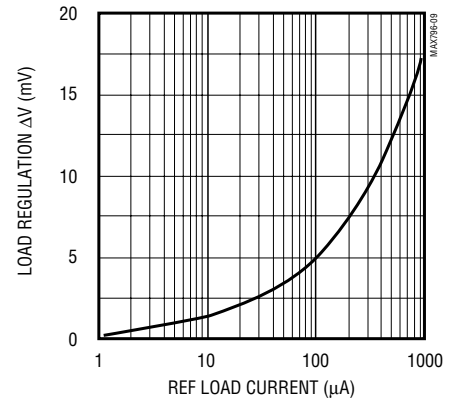

VL LOAD-REGULATION ERROR vs. LOAD CURRENT

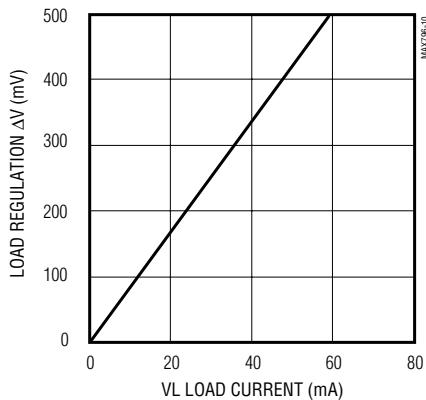

SWITCHING FREQUENCY vs. LOAD CURRENT

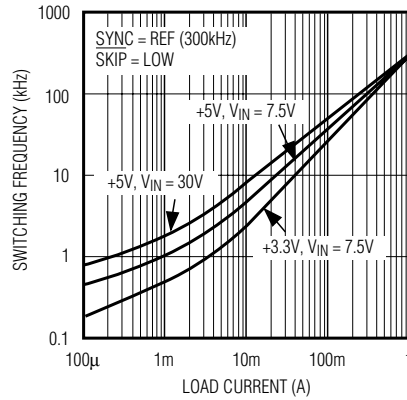

MAX796 MAXIMUM SECONDARY CURRENT vs. SUPPLY VOLTAGE, 5V/15V CIRCUIT

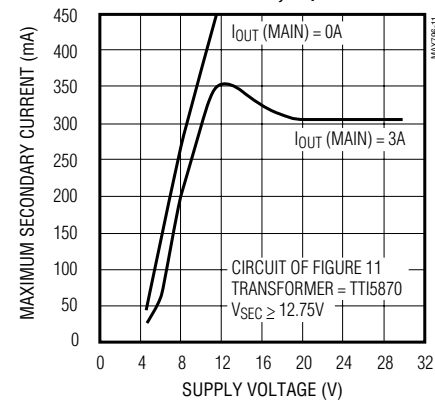

Step-Down Controllers with Synchronous Rectifier for CPU Power

Typical Operating Characteristics (continued)

($T_A = +25^\circ\text{C}$, unless otherwise noted.)

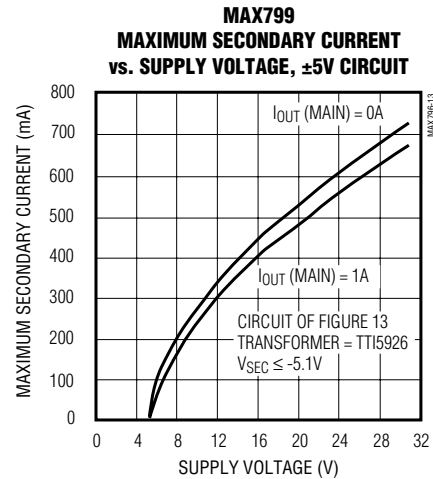
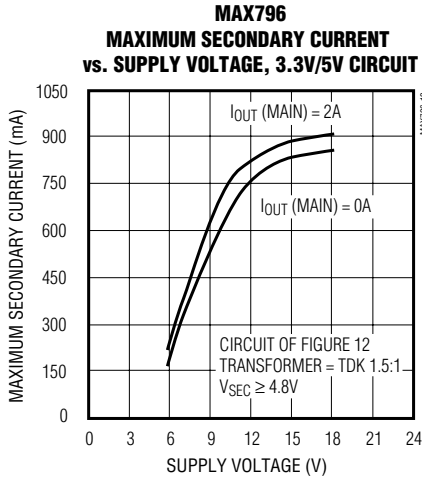

PULSE-WIDTH-MODULATION MODE WAVEFORMS

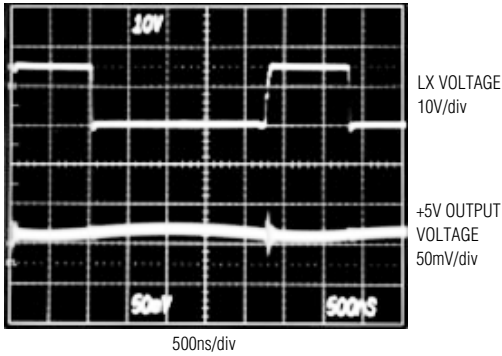

$I_{LOAD} = 1A$, $V_{IN} = 16V$,
CIRCUIT OF FIGURE 1

IDLE-MODE WAVEFORMS

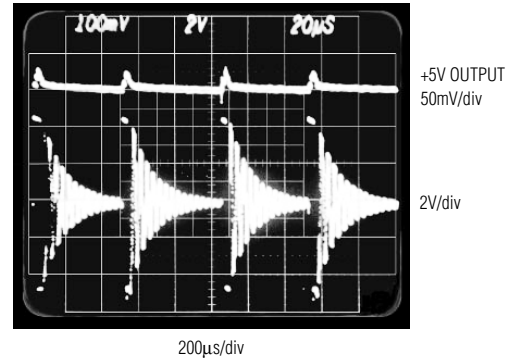

$I_{LOAD} = 100mA$, $V_{IN} = 10V$,
CIRCUIT OF FIGURE 1

+5V LOAD-TRANSIENT RESPONSE

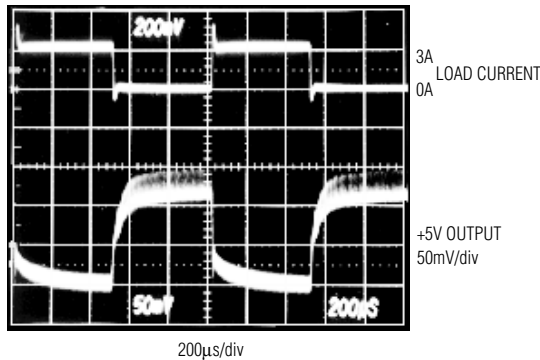

$V_{IN} = 15V$, CIRCUIT OF FIGURE 1

Step-Down Controllers with Synchronous Rectifier for CPU Power

Pin Description

MAX796/MAX797/MAX799

PIN	NAME	FUNCTION
1	SS	Soft-Start timing capacitor connection. Ramp time to full current limit is approximately 1ms/nF.
2	SECFB (MAX796/ MAX799)	Secondary winding Feedback input. Normally connected to a resistor divider from an auxiliary output. Don't leave SECFB unconnected. <ul style="list-style-type: none"> MAX796: SECFB regulates at VSECFB = 2.505V. Tie to VL if not used. MAX799: SECFB regulates at VSECFB = 0V. Tie to a negative voltage through a high-value current-limiting resistor ($I_{MAX} = 100\mu A$) if not used.
	$\overline{\text{SKIP}}$ (MAX797)	Disables pulse-skipping mode when high. Connect to GND for normal use. Don't leave $\overline{\text{SKIP}}$ unconnected. With $\overline{\text{SKIP}}$ grounded, the device will <i>automatically</i> change from pulse-skipping operation to full PWM operation when the load current exceeds approximately 30% of maximum. (See Table 3.)
3	REF	Reference voltage output. Bypass to GND with 0.33 μ F minimum.
4	GND	Low-noise analog Ground and feedback reference point.
5	SYNC	Oscillator Synchronization and frequency select. Tie to GND or VL for 150kHz operation; tie to REF for 300kHz operation. A high-to-low transition begins a new cycle. Drive SYNC with 0V to 5V logic levels (see the <i>Electrical Characteristics</i> table for V_{IH} and V_{IL} specifications). SYNC capture range is 190kHz to 340kHz guaranteed.
6	$\overline{\text{SHDN}}$	Shutdown control input, active low. Logic threshold is set at approximately 1V (V_{TH} of an internal N-channel MOSFET). Tie SHDN to V+ for automatic start-up.
7	FB	Feedback input. Regulates at FB = REF (approximately 2.505V) in adjustable mode. FB is a Dual-Mode™ input that also selects the fixed output voltage settings as follows: <ul style="list-style-type: none"> Connect to GND for 3.3V operation. Connect to VL for 5V operation. Connect FB to a resistor divider for adjustable mode. FB can be driven with +5V rail-to-rail logic in order to change the output voltage under system control.
8	CSH	Current-Sense input, High side. Current-limit level is 100mV referred to CSL.
9	CSL	Current-Sense input, Low side. Also serves as the feedback input in fixed-output modes.
10	V+	Battery voltage input (4.5V to 30V). Bypass V+ to PGND close to the IC with a 0.1 μ F capacitor. Connects to a linear regulator that powers VL.
11	VL	5V Internal linear-regulator output. VL is also the supply voltage rail for the chip. VL is switched to the output voltage via CSL ($V_{CSL} > 4.5V$) for automatic bootstrapping. Bypass to GND with 4.7 μ F. VL can supply up to 5mA for external loads.
12	PGND	Power Ground.
13	DL	Low-side gate-drive output. Normally drives the synchronous-rectifier MOSFET. Swings 0V to VL.
14	BST	Boost capacitor connection for high-side gate drive (0.1 μ F).
15	LX	Switching node (inductor) connection. Can swing 2V below ground without hazard.
16	DH	High-side gate-drive output. Normally drives the main buck switch. DH is a floating driver output that swings from LX to BST, riding on the LX switching-node voltage.

Dual Mode is a trademark of Maxim Integrated Products.

Step-Down Controllers with Synchronous Rectifier for CPU Power

Standard Application Circuit

It is easy to adapt the basic MAX797 single-output 3.3V buck converter (Figure 1) to meet a wide range of applications with inputs up to 28V (limited by choice of external MOSFET). Simply substitute the appropriate components from Table 1. These circuits represent a good set of tradeoffs between cost, size, and efficiency while staying within the worst-case specification limits for stress-related parameters such as capacitor ripple current. Each of these circuits is rated for a continuous load current at $T_A = +85^\circ\text{C}$, as shown. The 1A, 2A and 10A applications can withstand a continuous output short-circuit to ground. The 3A and 5A applications can withstand a short circuit of many seconds duration, but the synchronous-rectifier MOSFET overheats, exceeding the manufacturer's ratings for junction temperature by 50°C or more.

If the 3A or 5A circuit must be guaranteed to withstand a continuous output short circuit indefinitely, see the section *MOSFET Switches* under *Selecting Other Components*. Don't change the frequency of these circuits without first recalculating component values (particularly inductance value at maximum battery voltage).

Detailed Description

The MAX796 is a BiCMOS, switch-mode power-supply controller designed primarily for buck-topology regulators in battery-powered applications where high efficiency and low quiescent supply current are critical. The MAX796 also works well in other topologies such as boost, inverting, and CLK due to the flexibility of its floating high-speed gate driver. Light-load efficiency is enhanced by automatic idle-mode operation—a variable-frequency pulse-skipping mode that reduces

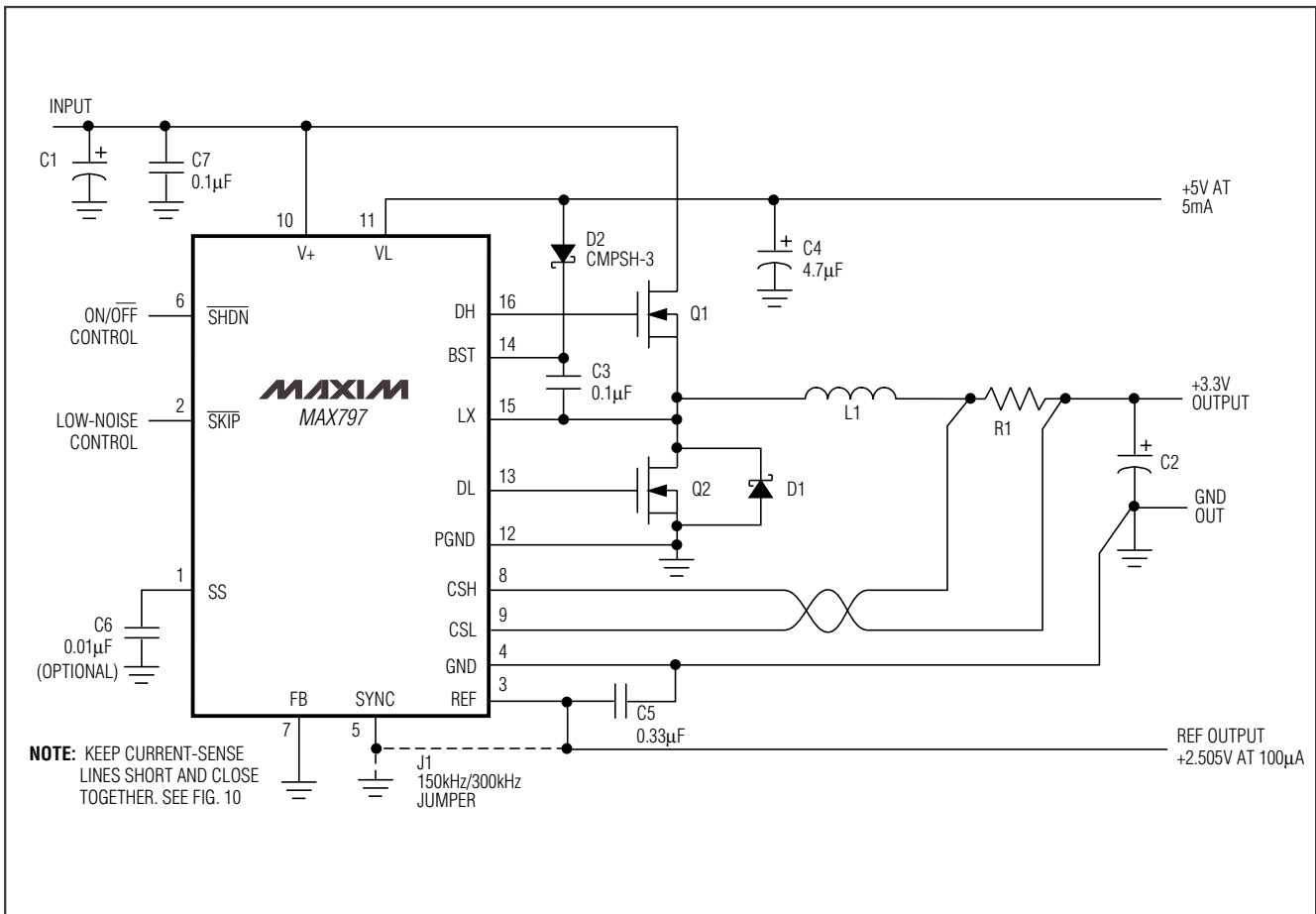

Figure 1. Standard 3.3V Application Circuit

Step-Down Controllers with Synchronous Rectifier for CPU Power

MAX796/MAX797/MAX799

Table 1. Component Selection for Standard 3.3V Applications

COMPONENT	LOAD CURRENT				
	1A	2A	3A	4A	10A
Input Range	4.75V to 18V	4.75V to 18V	4.75V to 28V	4.75V to 24V	4.5V to 6V
Application	PDA	Sub-Notebook	Notebook	High-End Notebook	Desktop 5V-to-3V
Frequency	150kHz	300kHz	300kHz	300kHz	300kHz
Q1 High-Side MOSFET	International Rectifier 1/2 IRF7101	Motorola 1/2 MMDF3N03HD or 1/2 Si9936	Motorola MMSF5N03HD or Si9410	Motorola MTD20N03HDL DPAK	Motorola MTD75N03HDL D ² PAK
Q2 Low-Side MOSFET	International Rectifier 1/2 IRF7101	Motorola 1/2 MMDF3N03HD or 1/2 Si9936	Motorola MMSF5N03HD or Si9410	Motorola MTD20N03HDL DPAK	Motorola MTD75N03HDL D ² PAK
C1 Input Capacitor	22μF, 35V AVX TPS or Sprague 595D	2 x 22μF, 35V AVX TPS or Sprague 595D	2 x 22μF, 35V AVX TPS or Sprague 595D	4 x 22μF, 35V AVX TPS or Sprague 595D	2 x 220μF, 10V Sanyo OS-CON 10SA220M
C2 Output Capacitor	150μF, 10V AVX TPS or Sprague 595D	150μF, 10V AVX TPS or Sprague 595D	220μF, 10V AVX TPS or Sprague 595D	3 x 220μF, 10V AVX TPS or Sprague 595D	4 x 220μF, 10V Sanyo OS-CON 10SA220M
D1 Rectifier	1N5817 Motorola MBR0502L SOD-89	1N5817 NIEC EC10QS02L or Motorola MBRS130T3	1N5819 NIEC EC10QS03 or Motorola MBRS130T3	1N5821 NIEC NSQ03A04 or Motorola MBRS340T3	1N5820 NIEC NSQ03A02, or Motorola MBRS340T3
R1 Resistor	0.062Ω IRC LR2010-01-R062	0.039Ω IRC LR2010-01-R039	0.025Ω IRC LR2010-01-R025	0.015Ω IRC LR2010-01-015	3 x 0.02Ω IRC LR2010-01-R020 (3 in parallel)
L1 Inductor	47μH, 1.2A Ferrite or Kool-Mu Sumida CD75-470	33μH, 2.2A Ferrite Dale LPE6562-330MB	10μH, 3A Ferrite Sumida CDRH125	4.7μH, 5.5A Ferrite Coilcraft DO3316-472	1.5μH, 11A, 3.5mΩ Coiltronics CTX03-12357-1

Table 2. Component Suppliers

MANUFACTURER	USA PHONE	FACTORY FAX [Country Code]
AVX	(803) 946-0690	[1] 803-626-3123
Central Semiconductor	(516) 435-1110	[1] 516-435-1824
Coilcraft	(847) 639-6400	[1] 847-639-1469
Coiltronics	(561) 241-7876	[1] 561-241-9339
Dale	(605) 668-4131	[1] 605-665-1627
International Rectifier	(310) 322-3331	[1] 310-322-3332
IRC	(512) 992-7900	[1] 512-992-3377
Kemet	(864) 963-6300	[1] 864-963-6521
Matsuo	(714) 969-2491	[1] 714-960-6492
Motorola	(602) 303-5454	[1] 602-994-6430

* Distributor

MANUFACTURER	USA PHONE	FACTORY FAX [Country Code]
Murata-Erie	(814) 237-1431 (800) 831-9172	[1] 814-238-0490
NIEC	(805) 867-2555*	[81] 3-3494-7414
Sanyo	(619) 661-6835	[81] 7-2070-1174
Siliconix	(408) 988-8000 (800) 554-5565	[1] 408-970-3950
Sprague	(603) 224-1961	[1] 603-224-1430
Sumida	(847) 956-0666	[81] 3-3607-5144
TDK	(847) 390-4461	[1] 847-390-4405
Transpower Technologies	(702) 831-0140	[1] 702-831-3521

losses due to MOSFET gate charge. The step-down power-switching circuit consists of two N-channel MOSFETs, a rectifier, and an LC output filter. The output voltage is the average of the AC voltage at the switching node, which is adjusted and regulated by changing the duty cycle of the MOSFET switches. The

gate-drive signal to the N-channel high-side MOSFET must exceed the battery voltage and is provided by a flying capacitor boost circuit that uses a 100nF capacitor connected to BST.

The MAX796 contains nine major circuit blocks, which are shown in Figure 2.

Step-Down Controllers with Synchronous Rectifier for CPU Power

MAX796/MAX797/MAX799

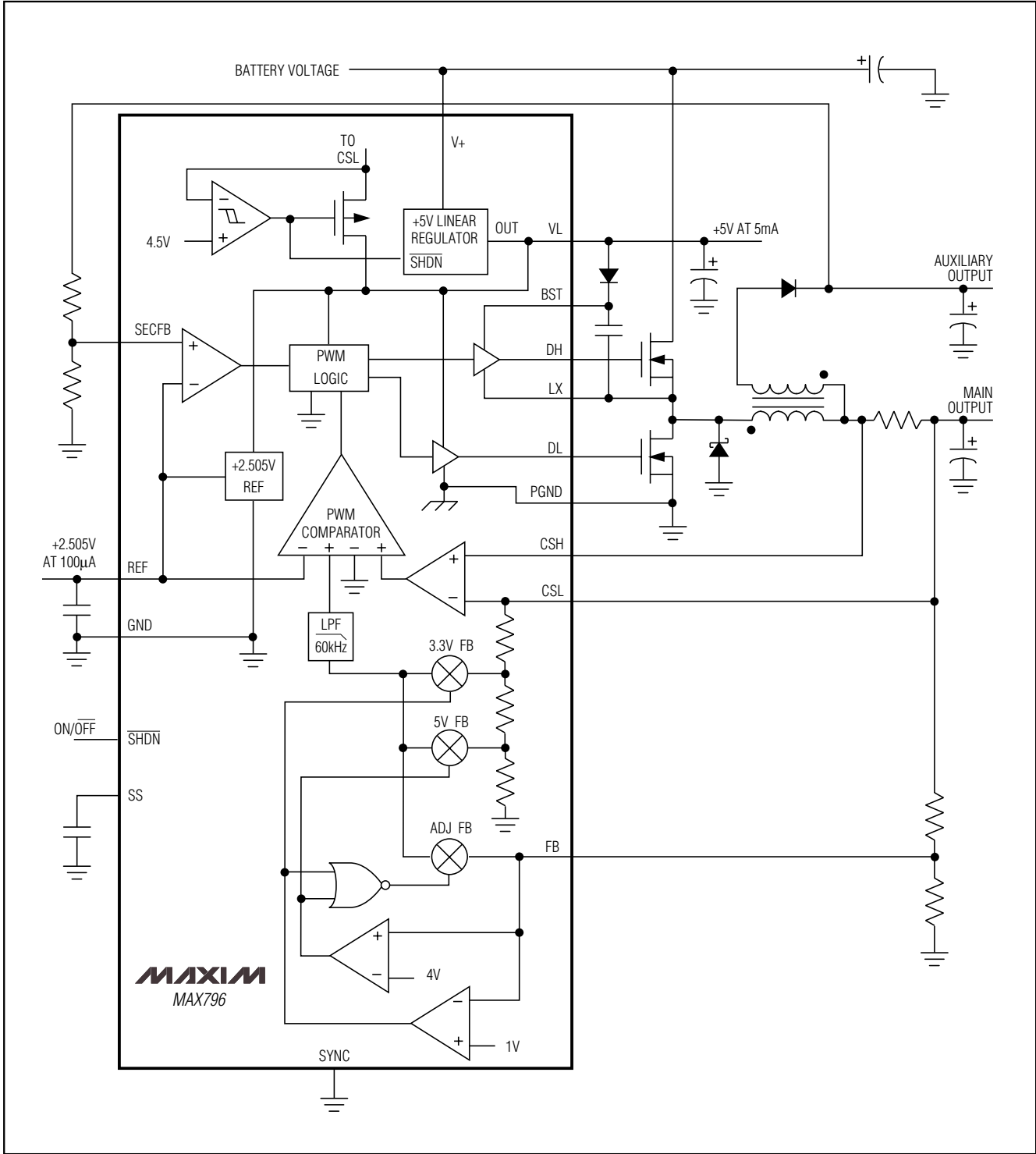

Figure 2. MAX796 Block Diagram

Step-Down Controllers with Synchronous Rectifier for CPU Power

PWM Controller Blocks:

- Multi-Input PWM Comparator
- Current-Sense Circuit
- PWM Logic Block
- Dual-Mode Internal Feedback Mux
- Gate-Driver Outputs
- Secondary Feedback Comparator

Bias Generator Blocks:

- +5V Linear Regulator
- Automatic Bootstrap Switchover Circuit
- +2.505V Reference

These internal IC blocks aren't powered directly from the battery. Instead, a +5V linear regulator steps down the battery voltage to supply both the IC internal rail (VL pin) as well as the gate drivers. The synchronous-switch gate driver is directly powered from +5V VL, while the high-side-switch gate driver is indirectly powered from VL via an external diode-capacitor boost circuit. An automatic bootstrap circuit turns off the +5V linear regulator and powers the IC from its output voltage if the output is above 4.5V.

PWM Controller Block

The heart of the current-mode PWM controller is a multi-input open-loop comparator that sums three signals: output voltage error signal with respect to the reference voltage, current-sense signal, and slope compensation ramp (Figure 3). The PWM controller is a direct summing type, lacking a traditional error amplifier and the phase shift associated with it. This direct-summing configuration approaches the ideal of cycle-by-cycle control over the output voltage.

Under heavy loads, the controller operates in full PWM mode. Each pulse from the oscillator sets the main PWM latch that turns on the high-side switch for a period determined by the duty factor (approximately V_{OUT}/V_{IN}). As the high-switch turns off, the synchronous rectifier latch is set. 60ns later the low-side switch turns on, and stays on until the beginning of the next clock cycle (in continuous mode) or until the inductor current crosses zero (in discontinuous mode). Under fault conditions where the inductor current exceeds the 100mV current-limit threshold, the high-side latch resets and the high-side switch turns off.

At light loads ($\overline{SKIP} = \text{low}$), the inductor current fails to exceed the 30mV threshold set by the minimum-current comparator. When this occurs, the controller goes into idle mode, skipping most of the oscillator pulses in order to reduce the switching frequency and cut back gate-charge losses. The oscillator is effectively gated off at light loads because the minimum-current comparator immediately resets the high-side latch at the

Table 3. Operating-Mode Truth Table

\overline{SHDN}	\overline{SKIP}	LOAD CURRENT	MODE NAME	DESCRIPTION
Low	X	X	Shutdown	All circuit blocks turned off; supply current = 1 μ A typ
High	Low	Low, <10%	Idle	Pulse-skipping; supply current = 700 μ A typ at $V_{IN} = 10V$; discontinuous inductor current
High	Low	Medium, <30%	Idle	Pulse-skipping; continuous inductor current
High	Low	High, >30%	PWM	Constant-frequency PWM; continuous inductor current
High	High	X	Low Noise* (PWM)	Constant-frequency PWM regardless of load; continuous inductor current even at no load

* MAX796/MAX799 have no \overline{SKIP} pin and therefore can't go into low-noise mode.

X = Don't Care

beginning of each cycle, unless the feedback signal falls below the reference voltage level.

When in PWM mode, the controller operates as a fixed-frequency current-mode controller where the duty ratio is set by the input/output voltage ratio. The current-mode feedback system regulates the peak inductor current as a function of the output voltage error signal. Since the average inductor current is nearly the same as the peak current, the circuit acts as a switch-mode transconductance amplifier and pushes the second output LC filter pole, normally found in a duty-factor-controlled (voltage-mode) PWM, to a higher frequency. To preserve inner-loop stability and eliminate regenerative inductor current "staircasing," a slope-compensation ramp is summed into the main PWM comparator to reduce the apparent duty factor to less than 50%.

The relative gains of the voltage- and current-sense inputs are weighted by the values of current sources that bias three differential input stages in the main PWM comparator (Figure 4). The relative gain of the voltage comparator to the current comparator is internally fixed at $K = 2:1$. The resulting loop gain (which is relatively low) determines the 2.5% typical load regulation error. The low loop-gain value helps reduce output filter capacitor size and cost by shifting the unity-gain crossover to a lower frequency.

Step-Down Controllers with Synchronous Rectifier for CPU Power

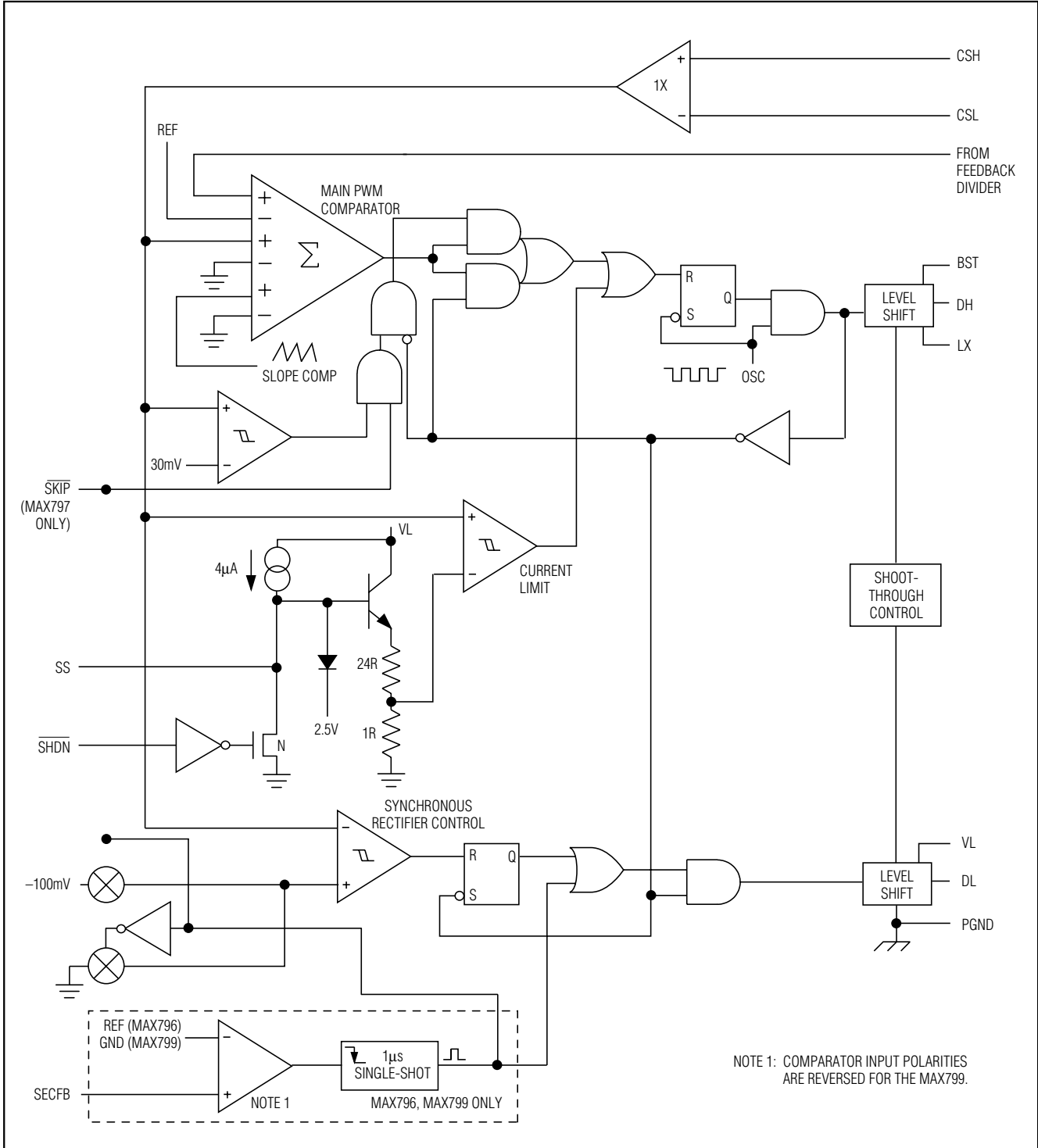

Figure 3. PWM Controller Detailed Block Diagram

Step-Down Controllers with Synchronous Rectifier for CPU Power

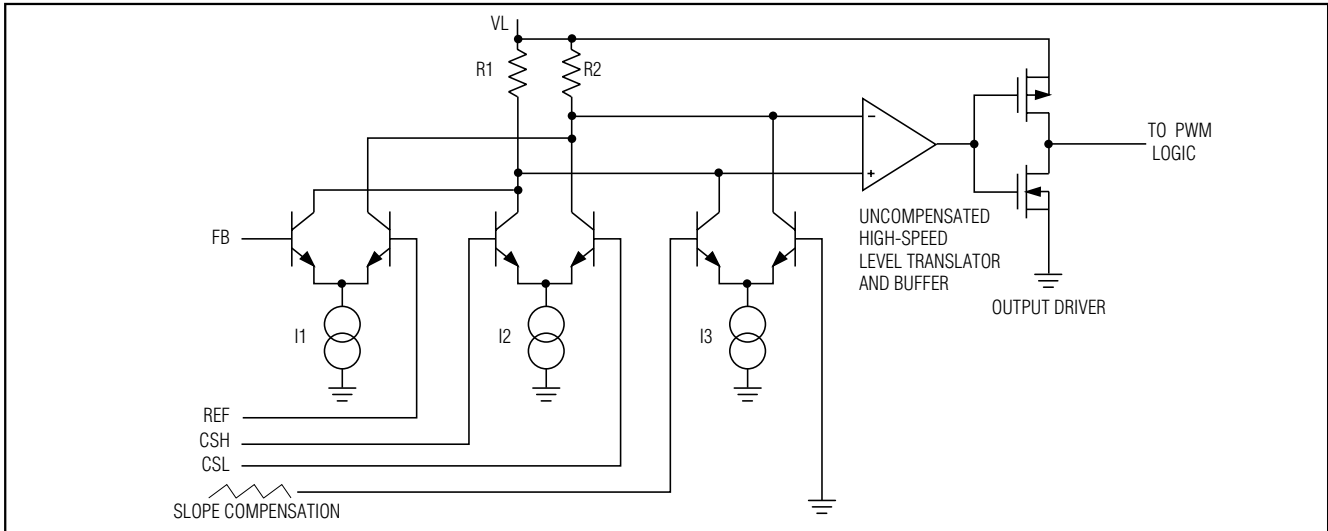

Figure 4. Main PWM Comparator Block Diagram

The output filter capacitor C2 sets a dominant pole in the feedback loop. This pole must roll off the loop gain to unity before the zero introduced by the output capacitor's parasitic resistance (ESR) is encountered (see *Design Procedure* section). A 60kHz pole-zero cancellation filter provides additional rolloff above the unity-gain crossover. This internal 60kHz lowpass compensation filter cancels the zero due to the filter capacitor's ESR. The 60kHz filter is included in the loop in both fixed- and adjustable-output modes.

Synchronous-Rectifier Driver (DL Pin)

Synchronous rectification reduces conduction losses in the rectifier by shunting the normal Schottky diode with a low-resistance MOSFET switch. The synchronous rectifier also ensures proper start-up of the boost-gate driver circuit. If you must omit the synchronous power MOSFET for cost or other reasons, replace it with a small-signal MOSFET such as a 2N7002.

If the circuit is operating in continuous-conduction mode, the DL drive waveform is simply the complement of the DH high-side drive waveform (with controlled dead time to prevent cross-conduction or "shoot-through"). In discontinuous (light-load) mode, the synchronous switch is turned off as the inductor current falls through zero. The synchronous rectifier works under all operating conditions, including idle mode. The synchronous-switch timing is further controlled by the secondary feedback (SECFB) signal in order to improve multiple-output cross-regulation (see *Secondary Feedback-Regulation Loop* section).

Internal VL and REF Supplies

An internal regulator produces the 5V supply (VL) that powers the PWM controller, logic, reference, and other blocks within the MAX796. This +5V low-dropout linear regulator can supply up to 5mA for external loads, with a reserve of 20mA for gate-drive power. Bypass VL to GND with 4.7μF. **Important:** VL must not be allowed to exceed 6V. Measure VL with the main output fully loaded. If VL is being pumped up above 5.5V, the probable cause is either excessive boost-diode capacitance or excessive ripple at V+. Use only small-signal diodes for D2 (1N4148 preferred) and bypass V+ to PGND with 0.1μF directly at the package pins.

The 2.505V reference (REF) is accurate to ±1.6% over temperature, making REF useful as a precision system reference. Bypass REF to GND with 0.33μF minimum. REF can supply up to 1mA for external loads. However, if tight-accuracy specs for either VOUT or REF are essential, avoid loading REF with more than 100μA. Loading REF reduces the main output voltage slightly, according to the reference-voltage load regulation error. In MAX799 applications, ensure that the SECFB divider doesn't load REF heavily.

When the main output voltage is above 4.5V, an internal P-channel MOSFET switch connects CSL to VL while simultaneously shutting down the VL linear regulator. This action bootstraps the IC, powering the internal circuitry from the output voltage, rather than through a linear regulator from the battery. Bootstrapping reduces power dissipation caused by gate-charge and quiescent losses by providing that power from a 90%-efficient switch-mode source, rather than from a 50%-efficient linear regulator.

Step-Down Controllers with Synchronous Rectifier for CPU Power

It's often possible to achieve a bootstrap-like effect, even for circuits that are set to $V_{OUT} < 4.5V$, by powering VL from an external-system +5V supply. To achieve this pseudo-bootstrap, add a Schottky diode between the external +5V source and VL, with the cathode to the VL side. This circuit provides a 1% to 2% efficiency boost and also extends the minimum battery input to less than 4V. The external source must be in the range of 4.8V to 6V. Another way to achieve a pseudo-bootstrap is to add an extra flyback winding to the main inductor to generate the +5V bootstrap source, as shown in the +3.3V/+5V Dual-Output Application (Figure 12).

Boost High-Side Gate-Driver Supply (BST Pin)

Gate-drive voltage for the high-side N-channel switch is generated by a flying-capacitor boost circuit as shown in Figure 5. The capacitor is alternately charged from the VL supply and placed in parallel with the high-side MOSFET's gate-source terminals.

On start-up, the synchronous rectifier (low-side MOSFET) forces LX to 0V and charges the BST capacitor to 5V. On the second half-cycle, the PWM turns on the high-side MOSFET by closing an internal switch between BST and DH. This provides the necessary enhancement voltage to turn on the high-side switch, an action that "boosts" the 5V gate-drive signal above the battery voltage.

Ringing seen at the high-side MOSFET gate (DH) in discontinuous-conduction mode (light loads) is a natural operating condition, and is caused by the residual energy in the tank circuit formed by the inductor and stray capacitance at the switching node LX. The gate-driver negative rail is referred to LX, so any ringing there is directly coupled to the gate-drive output.

Current-Limiting and Current-Sense Inputs (CSH and CSL)

The current-limit circuit resets the main PWM latch and turns off the high-side MOSFET switch whenever the voltage difference between CSH and CSL exceeds 100mV. This limiting is effective for both current flow directions, putting the threshold limit at $\pm 100mV$. The tolerance on the positive current limit is $\pm 20\%$, so the external low-value sense resistor must be sized for $80mV/R_1$ to guarantee enough load capability, while components must be designed to withstand continuous current stresses of $120mV/R_1$.

For breadboarding purposes or very high-current applications, it may be useful to wire the current-sense inputs with a twisted pair rather than PC traces. This twisted pair needn't be anything special, perhaps two pieces of wire-wrap wire twisted together.

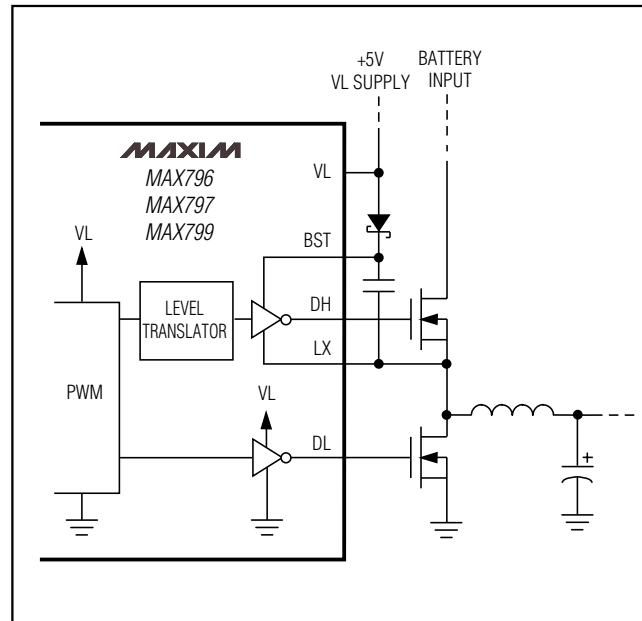

Figure 5. Boost Supply for Gate Drivers

Oscillator Frequency and Synchronization (SYNC Pin)

The SYNC input controls the oscillator frequency. Connecting SYNC to GND or to VL selects 150kHz operation; connecting SYNC to REF selects 300kHz. SYNC can also be used to synchronize with an external 5V CMOS or TTL clock generator. SYNC has a guaranteed 190kHz to 340kHz capture range.

300kHz operation optimizes the application circuit for component size and cost. 150kHz operation provides increased efficiency and improved load-transient response at low input-output voltage differences (see *Low-Voltage Operation* section).

Low-Noise Mode (SKIP Pin)

The low-noise mode (SKIP = high) is useful for minimizing RF and audio interference in noise-sensitive applications such as Soundblaster™ hi-fi audio-equipped systems, cellular phones, RF communicating computers, and electromagnetic pen-entry systems. See the summary of operating modes in Table 3. SKIP can be driven from an external logic signal.

The MAX797 can reduce interference due to switching noise by ensuring a constant switching frequency regardless of load and line conditions, thus concentrating the emissions at a known frequency outside the system audio or IF bands. Choose an oscillator fre-

Soundblaster is a trademark of Creative Labs.

Step-Down Controllers with Synchronous Rectifier for CPU Power

quency where harmonics of the switching frequency don't overlap a sensitive frequency band. If necessary, synchronize the oscillator to a tight-tolerance external clock generator.

The low-noise mode ($\overline{\text{SKIP}} = \text{high}$) forces two changes upon the PWM controller. First, it ensures fixed-frequency operation by disabling the minimum-current comparator and ensuring that the PWM latch is set at the beginning of each cycle, even if the output is in regulation. Second, it ensures continuous inductor current flow, and thereby suppresses discontinuous-mode inductor ringing by changing the reverse current-limit detection threshold from zero to -100mV , allowing the inductor current to reverse at very light loads.

In most applications, $\overline{\text{SKIP}}$ should be tied to GND in order to minimize quiescent supply current. Supply current with $\overline{\text{SKIP}}$ high is typically 10mA to 20mA , depending on external MOSFET gate capacitance and switching losses.

Forced continuous conduction via $\overline{\text{SKIP}}$ can improve cross regulation of transformer-coupled multiple-output supplies. This second function of the $\overline{\text{SKIP}}$ pin produces a result that is similar to the method of adding secondary regulation via the SECFB feedback pin, but with much higher quiescent supply current. Still, improving cross regulation by enabling $\overline{\text{SKIP}}$ instead of building in SECFB feedback can be useful in noise-sensitive applications, since SECFB and $\overline{\text{SKIP}}$ are mutually exclusive pins/functions in the MAX796 family.

Adjustable-Output Feedback (Dual-Mode FB Pin)

Adjusting the main output voltage with external resistors is easy for any of the devices in the MAX796 family, via the circuit of Figure 6. The nominal output voltage (given by the formula in Figure 6) should be set approximately 2% high in order to make up for the MAX796's -2.5% typical load-regulation error. For example, if designing for a 3.0V output, use a resistor ratio that results in a nominal output voltage of 3.06V . This slight offsetting gives the best possible accuracy. Recommended normal values for $R5$ range from $5\text{k}\Omega$ to $100\text{k}\Omega$. To achieve a 2.505V nominal output, simply connect FB to CSL directly. To achieve output voltages lower than 2.5V , use an external reference-voltage source higher than V_{REF} , as shown in Figure 7. For best accuracy, this second reference voltage should be much higher than V_{REF} . Alternatively, an external op amp could be used to gain-up REF in order to create the second reference source. This scheme requires a minimum load on the output in order to sink the $R3/R4$ divider current.

Remote sensing of the output voltage, while not possible in fixed-output mode due to the combined nature of the voltage- and current-sense input (CSL), is easy to achieve in adjustable mode by using the top of the external resistor divider as the remote sense point. Fixed-output accuracy is guaranteed to be $\pm 4\%$ over all conditions. In special circumstances, it may be necessary to improve upon this output accuracy. The High-Accuracy Adjustable-Output Application (Figure 18) provides $\pm 2.5\%$ accuracy by adding an integrator-type error amplifier.

The breakdown voltage rating of the current-sense inputs (7V absolute maximum) determines the 6V maximum output adjustment range. To extend this output range, add two matched resistor dividers and speed-up capacitors to form a level translator, as shown in Figure 8. Be sure to set these resistor ratios accurately (using 0.1% resistors), to avoid adding excessive error to the 100mV current-limit threshold.

Secondary Feedback-Regulation Loop (SECFB Pin)

A flyback winding control loop regulates a secondary winding output (MAX796/MAX799 only), improving cross-regulation when the primary is lightly loaded or when there is a low input-output differential voltage. If SECFB crosses its regulation threshold (V_{REF} for the

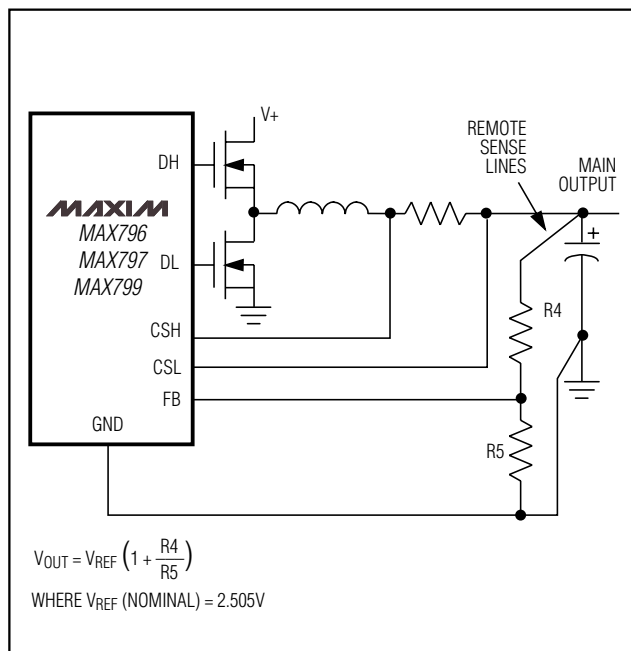

Figure 6. Adjusting the Main Output Voltage

Step-Down Controllers with Synchronous Rectifier for CPU Power

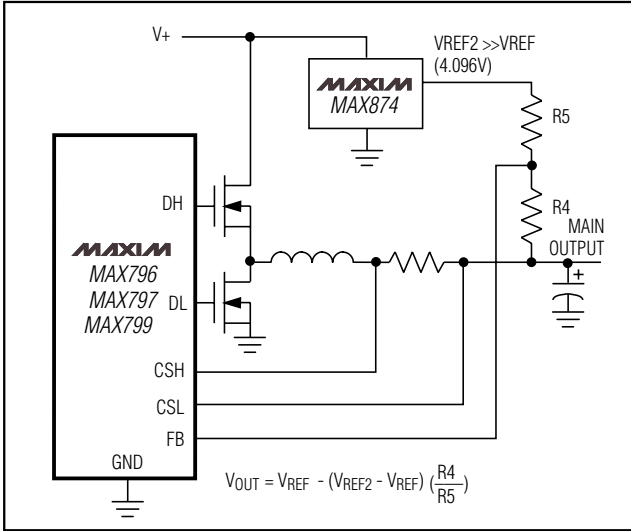

Figure 7. Output Voltage Less than 2.5V

MAX796), a 1μs one-shot is triggered that extends the low-side switch's on-time beyond the point where the inductor current crosses zero (in discontinuous mode). This causes the inductor (primary) current to reverse, which in turn pulls current out of the output filter capacitor and causes the flyback transformer to operate in the forward mode. The low impedance presented by the transformer secondary in the forward mode dumps current into the secondary output, charging up the secondary capacitor and bringing SECFB back into regulation. The SECFB feedback loop does not improve secondary output accuracy in normal flyback mode, where the main (primary) output is heavily loaded. In this mode, secondary output accuracy is determined, as usual, by the secondary rectifier drop, turns ratio, and accuracy of the main output voltage. So, a linear post-regulator may still be needed in order to meet tight output accuracy specifications.

The secondary output voltage-regulation point is determined by an external resistor divider at SECFB. For negative output voltages, the SECFB comparator is referenced to GND (MAX799); for positive output voltages, SECFB regulates at the 2.505V reference (MAX796). As a result, output resistor divider connections and design equations for the two device types differ slightly (Figure 9). Ordinarily, the secondary regulation point is set 5% to 10% below the voltage normally produced by the flyback effect. For example, if the output voltage as determined by the turns ratio is +15V, the feedback resistor ratio should be set to produce about +13.5V; otherwise, the SECFB one-shot might be triggered unintentionally, causing an unnecessary increase in supply current and output

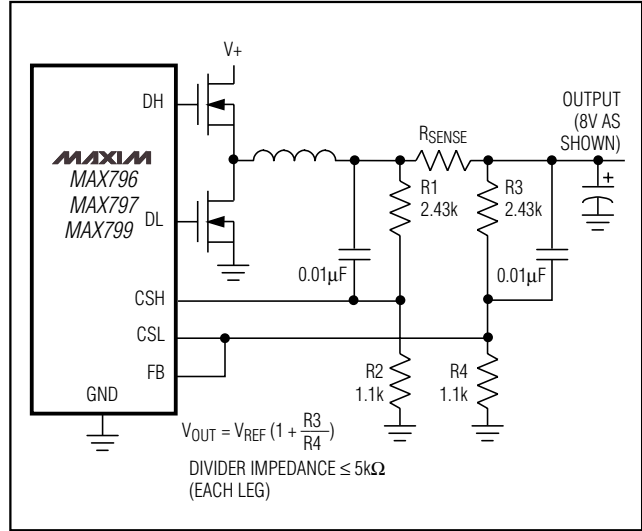

Figure 8. Adjusting the Output Voltage to Greater than 6V

noise. In negative-output (MAX799) applications, the resistor divider acts as a load on the internal reference, which in turn can cause errors at the main output. Avoid overloading REF (see the Reference Load-Regulation Error vs. Load Current graph in the *Typical Operating Characteristics*). 100kΩ is a good value for R3 in MAX799 circuits.

Soft-Start Circuit (SS)

Soft-start allows a gradual increase of the internal current-limit level at start-up for the purpose of reducing input surge currents, and perhaps for power-supply sequencing. In shutdown mode, the soft-start circuit holds the SS capacitor discharged to ground. When SHDN goes high, a 4μA current source charges the SS capacitor up to 3.2V. The resulting linear ramp waveform causes the internal current-limit level to increase proportionally from 20mV to 100mV. The main output capacitor thus charges up relatively slowly, depending on the SS capacitor value. The exact time of the output rise depends on output capacitance and load current and is typically 1ms per nanofarad of soft-start capacitance. With no SS capacitor connected, maximum current limit is reached within 10μs.

Shutdown

Shutdown mode ($\overline{\text{SHDN}} = 0\text{V}$) reduces the V+ supply current to typically 1μA. In this mode, the reference and VL are inactive. SHDN is a logic-level input, but it can be safely driven to the full V+ range. Connect SHDN to V+ for automatic start-up. Do not allow slow transitions (slower than 0.02V/μs) on SHDN.

Step-Down Controllers with Synchronous Rectifier for CPU Power

Design Procedure

The five pre-designed standard application circuits (Figure 1 and Table 1) contain ready-to-use solutions for common applications. Use the following design procedure to optimize the basic schematic for different voltage or current requirements. Before beginning a design, firmly establish the following:

V_{IN(MAX)}, the maximum input (battery) voltage. This value should include the worst-case conditions, such as no-load operation when a battery charger or AC adapter is connected but no battery is installed. V_{IN(MAX)} must not exceed 30V. This 30V upper limit is determined by the breakdown voltage of the BST floating gate driver to GND (36V absolute maximum).

V_{IN(MIN)}, the minimum input (battery) voltage. This should be taken at full-load under the lowest battery conditions. If V_{IN(MIN)} is less than 4.5V, a special circuit must be used to externally hold up V_L above 4.8V. If the minimum input-output difference is less than 1.5V, the filter capacitance required to maintain good AC load regulation increases.

Inductor Value

The exact inductor value isn't critical and can be adjusted freely in order to make tradeoffs among size, cost, and efficiency. Although lower inductor values will minimize size and cost, they will also reduce efficiency due to higher peak currents. To permit use of the physically smallest inductor, lower the inductance until the circuit is operating at the border between continuous and discontinuous modes. Reducing the inductor value even further, below this crossover point, results in discontinuous-conduction operation even at full load. This helps reduce output filter capacitance requirements but causes the core energy storage requirements to increase again. On the other hand, higher inductor values will increase efficiency, but at some point resistive losses due to extra turns of wire will exceed the benefit gained from lower AC current levels. Also, high inductor values can affect load-transient response; see the V_{SAG} equation in the *Low-Voltage Operation* section.

The following equations are given for continuous-conduction operation since the MAX796 is mainly intended for high-efficiency battery-powered applications. See Appendix A in Maxim's *Battery Management and DC-DC Converter Circuit Collection* for crossover point and discontinuous-mode equations. Discontinuous conduction doesn't affect normal idle-mode operation.

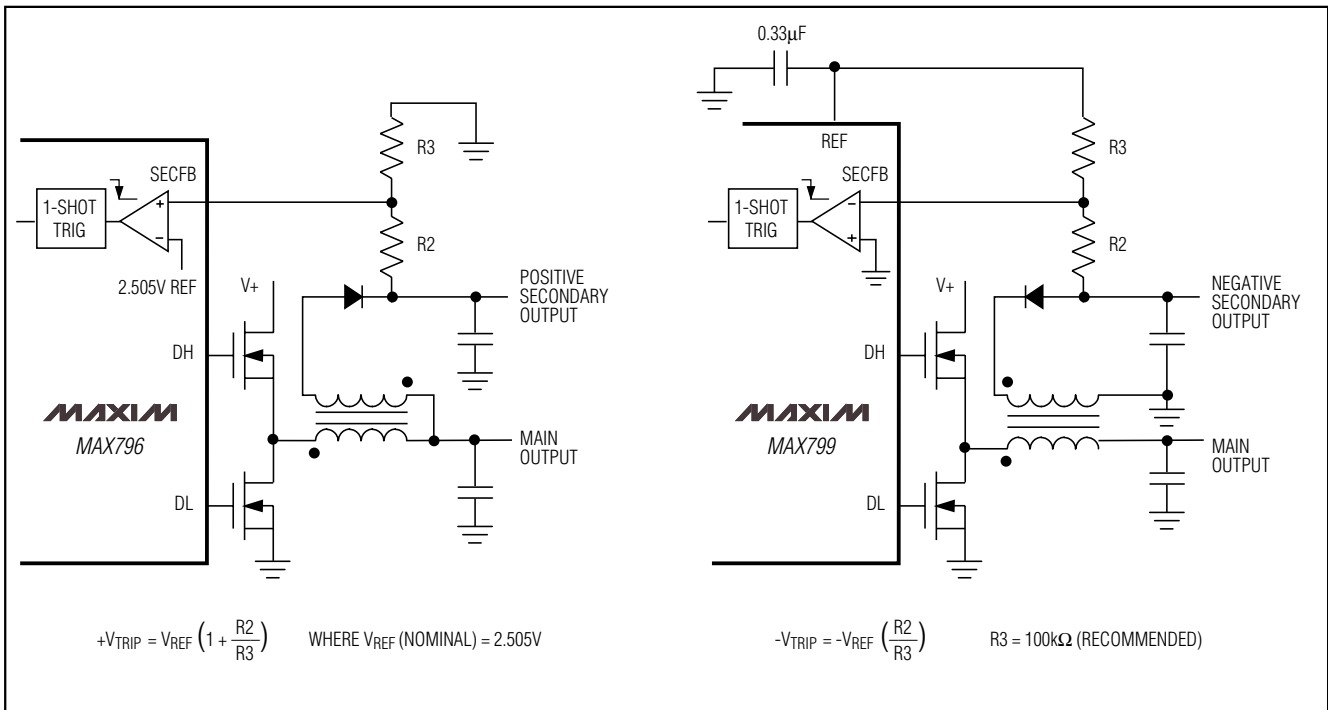

Figure 9. Secondary-Output Feedback Dividers, MAX796 vs. MAX799

Step-Down Controllers with Synchronous Rectifier for CPU Power

Three key inductor parameters must be specified: inductance value (L), peak current (I_{PEAK}), and DC resistance (R_{DC}). The following equation includes a constant LIR, which is the ratio of inductor peak-to-peak AC current to DC load current. A higher value of LIR allows smaller inductance, but results in higher losses and ripple. A good compromise between size and losses is found at a 30% ripple current to load current ratio (LIR = 0.3), which corresponds to a peak inductor current 1.15 times higher than the DC load current.

$$L = \frac{V_{OUT} (V_{IN(MAX)} - V_{OUT})}{V_{IN(MAX)} \times f \times I_{OUT} \times LIR}$$

where: f = switching frequency, normally 150kHz or 300kHz

I_{OUT} = maximum DC load current

LIR = ratio of AC to DC inductor current, typically 0.3

The peak inductor current at full load is 1.15 x I_{OUT} if the above equation is used; otherwise, the peak current can be calculated by:

$$I_{PEAK} = I_{LOAD} + \frac{V_{OUT} (V_{IN(MAX)} - V_{OUT})}{2 \times f \times L \times V_{IN(MAX)}}$$

The inductor's DC resistance is a key parameter for efficiency performance and must be ruthlessly minimized, preferably to less than 25mΩ at I_{OUT} = 3A. If a standard off-the-shelf inductor is not available, choose a core with an LI² rating greater than L x I_{PEAK}² and wind it with the largest diameter wire that fits the winding area. For 300kHz applications, ferrite core material is strongly preferred; for 150kHz applications, Kool-mu (aluminum alloy) and even powdered iron can be acceptable. If light-load efficiency is unimportant (in desktop 5V-to-3V applications, for example) then low-permeability iron-powder cores, such as the Micrometals type found in Pulse Engineering's 2.1μH PE-53680, may be acceptable even at 300kHz. For high-current applications, shielded core geometries (such as toroidal or pot core) help keep noise, EMI, and switching-waveform jitter low.

Current-Sense Resistor Value

The current-sense resistor value is calculated according to the worst-case-low current-limit threshold voltage (from the *Electrical Characteristics* table) and the peak inductor current. The continuous-mode peak inductor-current calculations that follow are also useful for sizing the switches and specifying the inductor-current saturation ratings. In order to simplify the calculation, I_{LOAD}

may be used in place of I_{PEAK} if the inductor value has been set for LIR = 0.3 or less (high inductor values) and 300kHz operation is selected. Low-inductance resistors, such as surface-mount metal-film resistors, are preferred.

$$R_{SENSE} = \frac{80mV}{I_{PEAK}}$$

Input Capacitor Value

Place a small ceramic capacitor (0.1μF) between V+ and GND, close to the device. Also, connect a low-ESR bulk capacitor directly to the drain of the high-side MOSFET. Select the bulk input filter capacitor according to input ripple-current requirements and voltage rating, rather than capacitor value. Electrolytic capacitors that have low enough ESR to meet the ripple-current requirement invariably have more than adequate capacitance values. Aluminum-electrolytic capacitors such as Sanyo OS-CON or Nichicon PL are preferred over tantalum types, which could cause power-up surge-current failure, especially when connecting to robust AC adapters or low-impedance batteries. RMS input ripple current is determined by the input voltage and load current, with the worst possible case occurring at V_{IN} = 2 x V_{OUT}:

$$I_{RMS} = I_{LOAD} \times \frac{\sqrt{V_{OUT} (V_{IN} - V_{OUT})}}{V_{IN}}$$

$$I_{RMS} = I_{LOAD} / 2 \text{ when } V_{IN} \text{ is } 2 \times V_{OUT}$$

Output Filter Capacitor Value

The output filter capacitor values are generally determined by the ESR (effective series resistance) and voltage rating requirements rather than actual capacitance requirements for loop stability. In other words, the low-ESR electrolytic capacitor that meets the ESR requirement usually has more output capacitance than is required for AC stability. Use only specialized low-ESR capacitors intended for switching-regulator applications, such as AVX TPS, Sprague 595D, Sanyo OS-CON, or Nichicon PL series. To ensure stability, the capacitor must meet *both* minimum capacitance and maximum ESR values as given in the following equations:

$$C_F > \frac{V_{REF} (1 + V_{OUT} / V_{IN(MIN)})}{V_{OUT} \times R_{SENSE} \times f}$$

$$RESR < \frac{R_{SENSE} \times V_{OUT}}{V_{REF}}$$

(can be multiplied by 1.5, see note below)

Step-Down Controllers with Synchronous Rectifier for CPU Power

These equations are “worst-case” with 45 degrees of phase margin to ensure jitter-free fixed-frequency operation and provide a nicely damped output response for zero to full-load step changes. Some cost-conscious designers may wish to bend these rules by using less expensive (lower quality) capacitors, particularly if the load lacks large step changes. This practice is tolerable, provided that some bench testing over temperature is done to verify acceptable noise and transient response.

There is no well-defined boundary between stable and unstable operation. As phase margin is reduced, the first symptom is a bit of timing jitter, which shows up as blurred edges in the switching waveforms where the scope won't quite sync up. Technically speaking, this (usually) harmless jitter is unstable operation, since the switching frequency is now non-constant. As the capacitor quality is reduced, the jitter becomes more pronounced and the load-transient output voltage waveform starts looking ragged at the edges. Eventually, the load-transient waveform has enough ringing on it that the peak noise levels exceed the allowable output voltage tolerance. Note that even with zero phase margin and gross instability present, the output voltage noise never gets much worse than $I_{PEAK} \times R_{ESR}$ (under constant loads, at least).

Designers of RF communicators or other noise-sensitive analog equipment should be conservative and stick to the guidelines. Designers of notebook computers and similar commercial-temperature-range digital systems can multiply the R_{ESR} value by a factor of 1.5 without hurting stability or transient response.

The output voltage ripple is usually dominated by the ESR of the filter capacitor and can be approximated as $I_{RIPPLE} \times R_{ESR}$. There is also a capacitive term, so the full equation for ripple in the continuous mode is $V_{NOISE(p-p)} = I_{RIPPLE} \times (R_{ESR} + 1 / (2 \times \pi \times f \times C_F))$. In idle mode, the inductor current becomes discontinuous with high peaks and widely spaced pulses, so the noise can actually be higher at light load compared to full load. In idle mode, the output ripple can be calculated as:

$$V_{NOISE(p-p)} = \frac{0.02 \times R_{ESR}}{R_{SENSE}} + \frac{0.0003 \times L \times [1 / V_{OUT} + 1 / (V_{IN} - V_{OUT})]}{(R_{SENSE})^2 \times C_F}$$

Transformer Design (MAX796/MAX799 Only)

Buck-plus-flyback applications, sometimes called “coupled-inductor” topologies, need a transformer in order to generate multiple output voltages. The basic electrical design is a simple task of calculating turns ratios and adding the power delivered to the secondary in order to calculate the current-sense resistor and primary inductance. However, extremes of low input-output differentials, widely different output loading levels, and high turns ratios can complicate the design due to parasitic transformer parameters such as inter-winding capacitance, secondary resistance, and leakage inductance. For examples of what is possible with real-world transformers, see the graphs of Maximum Secondary Current vs. Input Voltage in the *Typical Operating Characteristics*.

Power from the main and secondary outputs is lumped together to obtain an equivalent current referred to the main output voltage (see Inductor L1 for definitions of parameters). Set the value of the current-sense resistor at $80mV / I_{TOTAL}$.

P_{TOTAL} = the sum of the output power from all outputs

$I_{TOTAL} = P_{TOTAL} / V_{OUT}$ = the equivalent output current referred to V_{OUT}

$$L(\text{primary}) = \frac{V_{OUT} (V_{IN(\text{MAX})} - V_{OUT})}{V_{IN(\text{MAX})} \times f \times I_{TOTAL} \times LIR}$$

$$\text{Turns Ratio } N = \frac{V_{SEC} + V_{FWD}}{V_{OUT(\text{MIN})} + V_{RECT} + V_{SENSE}}$$

where: V_{SEC} is the minimum required rectified secondary-output voltage

V_{FWD} is the forward drop across the secondary rectifier

$V_{OUT(\text{MIN})}$ is the *minimum* value of the main output voltage (from the *Electrical Characteristics*)

V_{RECT} is the on-state voltage drop across the synchronous-rectifier MOSFET

V_{SENSE} is the voltage drop across the sense resistor

In positive-output (MAX796) applications, the transformer secondary return is often referred to the main output voltage rather than to ground in order to reduce the needed turns ratio. In this case, the main output voltage must first be subtracted from the secondary voltage to obtain V_{SEC} .

Step-Down Controllers with Synchronous Rectifier for CPU Power

Selecting Other Components

MOSFET Switches

The two high-current N-channel MOSFETs must be logic-level types with guaranteed on-resistance specifications at $V_{GS} = 4.5V$. Lower gate threshold specs are better (i.e., 2V max rather than 3V max). Drain-source breakdown voltage ratings must at least equal the maximum input voltage, preferably with a 20% derating factor. The best MOSFETs will have the lowest on-resistance per nanocoulomb of gate charge. Multiplying $R_{DS(ON)} \times Q_G$ provides a meaningful figure by which to compare various MOSFETs. Newer MOSFET process technologies with dense cell structures generally give the best performance. The internal gate drivers can tolerate $>100nC$ total gate charge, but 70nC is a more practical upper limit to maintain best switching times.

In high-current applications, MOSFET package power dissipation often becomes a dominant design factor. I^2R power losses are the greatest heat contributor for both high- and low-side MOSFETs. I^2R losses are distributed between Q1 and Q2 according to duty factor (see the equations below). Switching losses affect the upper MOSFET only, since the Schottky rectifier clamps the switching node before the synchronous rectifier turns on. Gate-charge losses are dissipated by the driver and don't heat the MOSFET. Ensure that both MOSFETs are within their maximum junction temperature at high ambient temperature by calculating the temperature rise according to package thermal-resistance specifications. The worst-case dissipation for the high-side MOSFET occurs at the minimum battery voltage, and the worst-case for the low-side MOSFET occurs at the maximum battery voltage.

$$PD \text{ (upper FET)} = I_{LOAD}^2 \times R_{DS(ON)} \times DUTY + V_{IN} \times I_{LOAD} \times f \times \left(\frac{V_{IN} \times C_{RSS}}{I_{GATE}} + 20ns \right)$$

$$PD \text{ (lower FET)} = I_{LOAD}^2 \times R_{DS(ON)} \times (1 - DUTY) \\ DUTY = (V_{OUT} + V_{Q2}) / (V_{IN} - V_{Q1})$$

where: $I_{LOAD} \times R_{DS(ON)}$ = On-state voltage drop V_{Q_1}
 C_{RSS} = MOSFET reverse transfer capacitance
 I_{GATE} = DH driver peak output current capability (1A typically)
 20ns = DH driver inherent rise/fall time

Under output short circuit, the synchronous-rectifier MOSFET suffers extra stress and may need to be oversized if a continuous DC short circuit must be tolerated.

During short circuit, Q2's duty factor can increase to greater than 0.9 according to:

$$Q2 \text{ DUTY (short circuit)} = 1 - [V_{Q2} / (V_{IN(MAX)} - V_{Q1})] \\ \text{where the on-state voltage drop } V_Q = (120mV / R_{SENSE}) \times R_{DS(ON)}$$

Rectifier Diode D1

Rectifier D1 is a clamp that catches the negative inductor swing during the 110ns dead time between turning off the high-side MOSFET and turning on the low-side. D1 must be a Schottky type in order to prevent the lossy parasitic MOSFET body diode from conducting. It is acceptable to omit D1 and let the body diode clamp the negative inductor swing, but efficiency will drop one or two percent as a result. Use an MBR0530 (500mA rated) type for loads up to 1.5A, a 1N5819 type for loads up to 3A, or a 1N5822 type for loads up to 10A. D1's rated reverse breakdown voltage must be at least equal to the maximum input voltage, preferably with a 20% derating factor.

Boost-Supply Diode D2

A signal diode such as a 1N4148 works well for D2 in most applications. If the input voltage can go below 6V, use a small (20mA) Schottky diode for slightly improved efficiency and dropout characteristics. Don't use large power diodes such as 1N5817 or 1N4001, since high junction capacitance can cause V_L to be pumped up to excessive voltages.

Rectifier Diode D3 (Transformer Secondary Diode)

The secondary diode in coupled-inductor applications must withstand high flyback voltages greater than 60V, which usually rules out most Schottky rectifiers. Common silicon rectifiers such as the 1N4001 are also prohibited, as they are far too slow. This often makes fast silicon rectifiers such as the MURS120 the only choice. The flyback voltage across the rectifier is related to the $V_{IN}-V_{OUT}$ difference according to the transformer turns ratio:

$$V_{FLYBACK} = V_{SEC} + (V_{IN} - V_{OUT}) \times N$$

where: N is the transformer turns ratio SEC/PRI
 V_{SEC} is the maximum secondary DC output voltage
 V_{OUT} is the primary (main) output voltage

Subtract the main output voltage (V_{OUT}) from $V_{FLYBACK}$ in this equation if the secondary winding is returned to V_{OUT} and not to ground. The diode reverse breakdown rating must also accommodate any ringing due to leakage inductance. D3's current rating should be at least twice the DC load current on the secondary output.

Step-Down Controllers with Synchronous Rectifier for CPU Power

Low-Voltage Operation

Low input voltages and low input-output differential voltages each require some extra care in the design. Low absolute input voltages can cause the VL linear regulator to enter dropout, and eventually shut itself off. Low input voltages relative to the output (low $V_{IN}-V_{OUT}$ differential) can cause bad load regulation in multi-output flyback applications. See the design equations in the *Transformer Design* section. Finally, low $V_{IN}-V_{OUT}$ differentials can also cause the output voltage to sag when the load current changes abruptly. The amplitude of the sag is a function of inductor value and maximum duty factor (an *Electrical Characteristics* parameter, 93% guaranteed over temperature at $f = 150\text{kHz}$) as follows:

$$V_{SAG} = \frac{(I_{STEP})^2 \times L}{2 \times C_F \times (V_{IN(MIN)} \times D_{MAX} - V_{OUT})}$$

The cure for low-voltage sag is to increase the value of the output capacitor. For example, at $V_{IN} = 5.5\text{V}$, $V_{OUT} = 5\text{V}$, $L = 10\mu\text{H}$, $f = 150\text{kHz}$, a total capacitance of $660\mu\text{F}$ will prevent excessive sag. Note that only the capacitance requirement is increased and the ESR requirements don't change. Therefore, the added capacitance can be supplied by a low-cost bulk capacitor in parallel with the normal low-ESR capacitor.

Applications Information

Heavy-Load Efficiency Considerations

The major efficiency loss mechanisms under loads are, in the usual order of importance:

- $P(I^2R)$, I^2R losses
- $P(\text{gate})$, gate-charge losses
- $P(\text{diode})$, diode-conduction losses
- $P(\text{tran})$, transition losses
- $P(\text{cap})$, capacitor ESR losses
- $P(\text{IC})$, losses due to the operating supply current of the IC

Inductor-core losses are fairly low at heavy loads because the inductor's AC current component is small. Therefore, they aren't accounted for in this analysis. Ferrite cores are preferred, especially at 300kHz , but powdered cores such as Kool-mu can work well.

$$\begin{aligned} \text{Efficiency} &= P_{OUT} / P_{IN} \times 100\% \\ &= P_{OUT} / (P_{OUT} + P_{TOTAL}) \times 100\% \end{aligned}$$

$$P_{TOTAL} = P(I^2R) + P(\text{gate}) + P(\text{diode}) + P(\text{tran}) + P(\text{cap}) + P(\text{IC})$$

$$P(I^2R) = (I_{LOAD})^2 \times (R_{DC} + R_{DS(ON)} + R_{SENSE})$$

where R_{DC} is the DC resistance of the coil, $R_{DS(ON)}$ is the MOSFET on-resistance, and R_{SENSE} is the current-

Table 4. Low-Voltage Troubleshooting

SYMPTOM	CONDITION	ROOT CAUSE	SOLUTION
Sag or droop in V_{OUT} under step load change	Low $V_{IN}-V_{OUT}$ differential, $<1.5\text{V}$	Limited inductor-current slew rate per cycle.	Increase bulk output capacitance per formula above. Reduce inductor value.
Dropout voltage is too high (V_{OUT} follows V_{IN} as V_{IN} decreases)	Low $V_{IN}-V_{OUT}$ differential, $<1\text{V}$	Maximum duty-cycle limits exceeded.	Reduce f to 150kHz . Reduce MOSFET on-resistance and coil DCR.
Unstable—jitters between two distinct duty factors	Low $V_{IN}-V_{OUT}$ differential, $<1\text{V}$	Inherent limitation of fixed-frequency current-mode SMPS slope compensation.	Reduce L value. Tolerate the remaining jitter (extra output capacitance helps somewhat).
Secondary output won't support a load	Low $V_{IN}-V_{OUT}$ differential, $V_{IN} < 1.3 \times V_{OUT(\text{main})}$ (MAX796/MAX799 only)	Not enough duty cycle left to initiate forward-mode operation. Small AC current in primary can't store energy for flyback operation.	Reduce f to 150kHz . Reduce secondary impedances—use Schottky if possible. Stack secondary winding on main output.
High supply current, poor efficiency	Low input voltage, $<5\text{V}$	VL linear regulator is going into dropout and isn't providing good gate-drive levels.	Use a small 20mA Schottky diode for boost diode D2. Supply VL from an external source.
Won't start under load or quits before battery is completely dead	Low input voltage, $<4.5\text{V}$	VL output is so low that it hits the VL UVLO threshold at 4.2V max.	Supply VL from an external source other than V_{BATT} , such as the system 5V supply.

Step-Down Controllers with Synchronous Rectifier for CPU Power

sense resistor value. The $R_{DS(ON)}$ term assumes identical MOSFETs for the high- and low-side switches because they time-share the inductor current. If the MOSFETs aren't identical, their losses can be estimated by averaging the losses according to duty factor.

$$P(\text{gate}) = \text{gate-driver loss} = q_G \times f \times V_L$$

where V_L is the MAX796 internal logic supply voltage (5V), and q_G is the sum of the gate-charge values for low- and high-side switches. For matched MOSFETs, q_G is twice the data sheet value of an individual MOSFET. If V_{OUT} is set to less than 4.5V, replace V_L in this equation with V_{BATT} . In this case, efficiency can be improved by connecting V_L to an efficient 5V source, such as the system +5V supply.

$$P(\text{diode}) = \text{diode conduction losses} \\ = I_{LOAD} \times V_{FWD} \times t_D \times f$$

where t_D is the diode conduction time (110ns typ) and V_{FWD} is the forward voltage of the Schottky.

$P_{D(\text{tran})}$ = transition loss =

$$V_{BATT} \times I_{LOAD} \times f \times \left(\frac{V_{BATT} \times C_{RSS}}{I_{GATE}} + 20\text{ns} \right)$$

where C_{RSS} is the reverse transfer capacitance of the high-side MOSFET (a data sheet parameter), I_{GATE} is the DH gate-driver peak output current (1A typ), and 20ns is the rise/fall time of the DH driver (20ns typ).

$$P(\text{cap}) = \text{input capacitor ESR loss} = (I_{RMS})^2 \times \text{RESR}$$

where I_{RMS} is the input ripple current as calculated in the *Input Capacitor Value* section of the *Design Procedure*.

Light-Load Efficiency Considerations

Under light loads, the PWM operates in discontinuous mode, where the inductor current discharges to zero at some point during the switching cycle. This causes the AC component of the inductor current to be high compared to the load current, which increases core losses and I^2R losses in the output filter capacitors. Obtain best light-load efficiency by using MOSFETs with moderate gate-charge levels and by using ferrite, MPP, or other low-loss core material. Avoid powdered iron cores; even Kool-mu (aluminum alloy) is not as good as ferrite.

PC Board Layout Considerations

Good PC board layout is *required* to achieve specified noise, efficiency, and stability performance. The PC board layout artist must be provided with explicit instructions, preferably a pencil sketch of the placement of power switching components and high-current routing. See the evaluation kit PC board layouts in the MAX796 and MAX797 EV kit manuals for examples. A

ground plane is essential for optimum performance. In most applications, the circuit will be located on a multi-layer board and full use of the four or more copper layers is recommended. Use the top layer for high-current connections, the bottom layer for quiet connections (REF, SS, GND), and the inner layers for an uninterrupted ground plane. Use the following step-by-step guide.

- 1) Place the high-power components (C1, C2, Q1, Q2, D1, L1, and R1) first, with their grounds adjacent.

Priority 1: **Minimize current-sense resistor trace lengths** (see Figure 10).

Priority 2: **Minimize ground trace lengths** in the high-current paths (discussed below).

Priority 3: Minimize other trace lengths in the high-current paths. Use >5mm wide traces. C1 to Q1: 10mm max length. D1 cathode to Q2: 5mm max length. LX node (Q1 source, Q2 drain, D1 cathode, inductor): 15mm max length

Ideally, surface-mount power components are butted up to one another with their ground terminals almost touching. These high-current grounds (C1-, C2-, source of Q2, anode of D1, and PGND) are then connected to each other with a wide filled zone of top-layer copper, so that they don't go through vias. The resulting top-layer "sub-ground-plane" is connected to the normal inner-layer ground plane at the output ground terminals. This ensures that the analog GND of the IC is sensing at the output terminals of the supply, without interference from IR drops and ground noise. Other high-current paths should also be minimized, **but focusing ruthlessly on short ground and current-sense connections eliminates about 90% of all PC layout headaches.** See the evaluation kit PC board layouts for examples.

- 2) Place the IC and signal components. Keep the main switching node (LX node) away from sensitive analog components (current-sense traces and REF and SS capacitors). Placing the IC and analog components on the opposite side of the board from the power-switching node is desirable. Important: the IC must be no farther than 10mm from the current-sense resistor. Keep the gate-drive traces (DH, DL, and BST) shorter than 20mm and route them away from CSH, CSL, REF, and SS.
- 3) Employ a single-point star ground where the input ground trace, power ground (sub-ground-plane), and normal ground plane all meet at the output ground terminal of the supply.

Step-Down Controllers with Synchronous Rectifier for CPU Power

MAX796/MAX797/MAX799

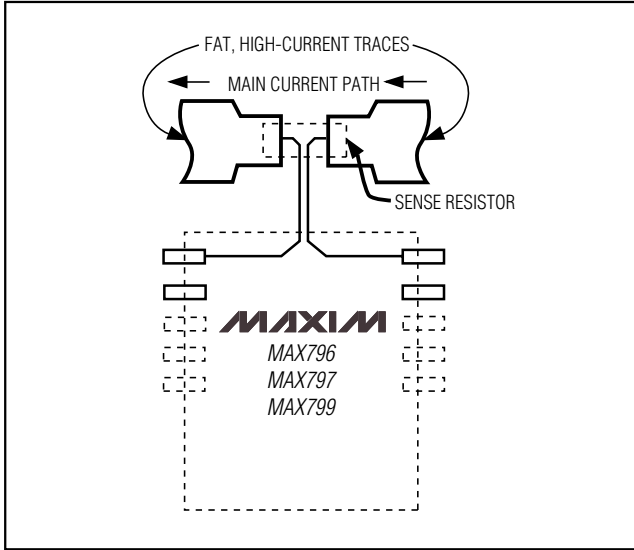

Figure 10. Kelvin Connections for the Current-Sense Resistor

Application Circuits

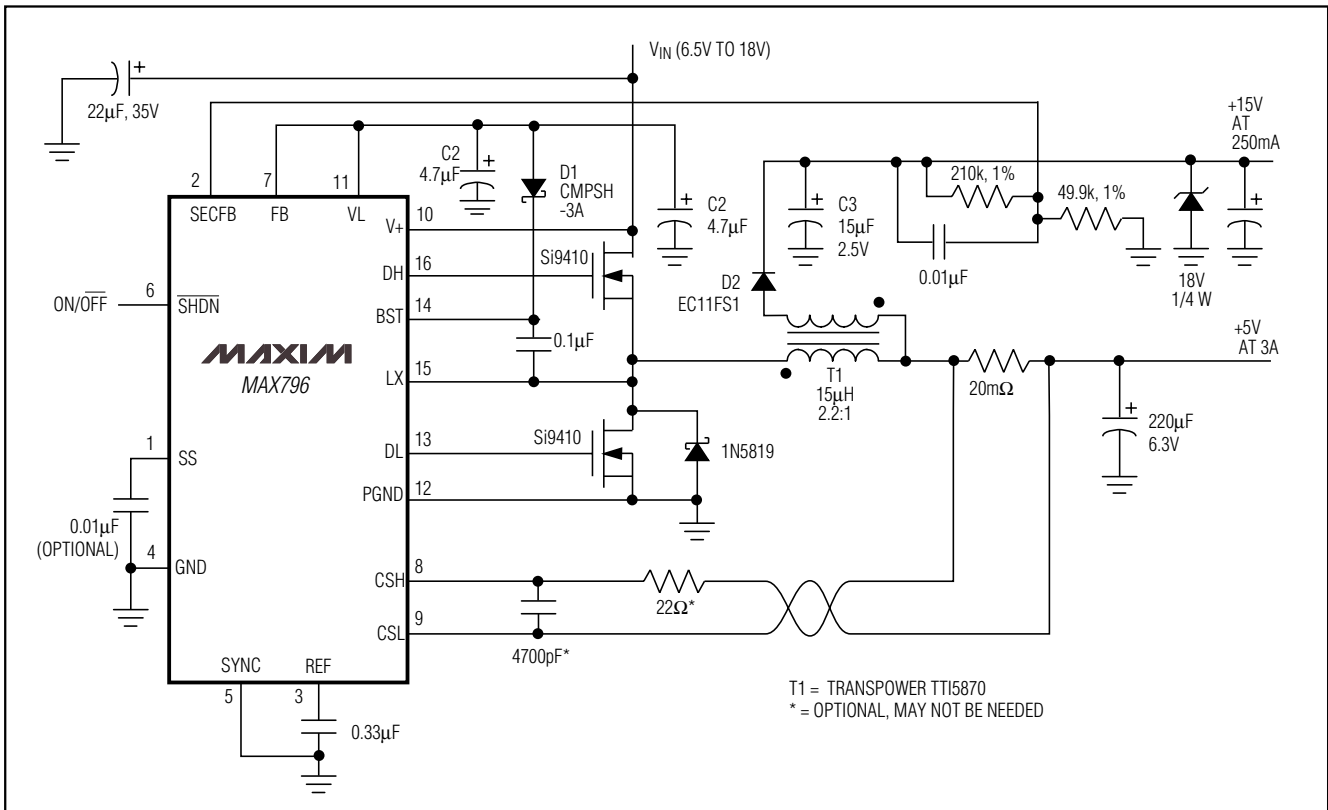

Figure 11. +5V/+15V Dual-Output Application (MAX796)

Step-Down Controllers with Synchronous Rectifier for CPU Power

Application Circuits (continued)

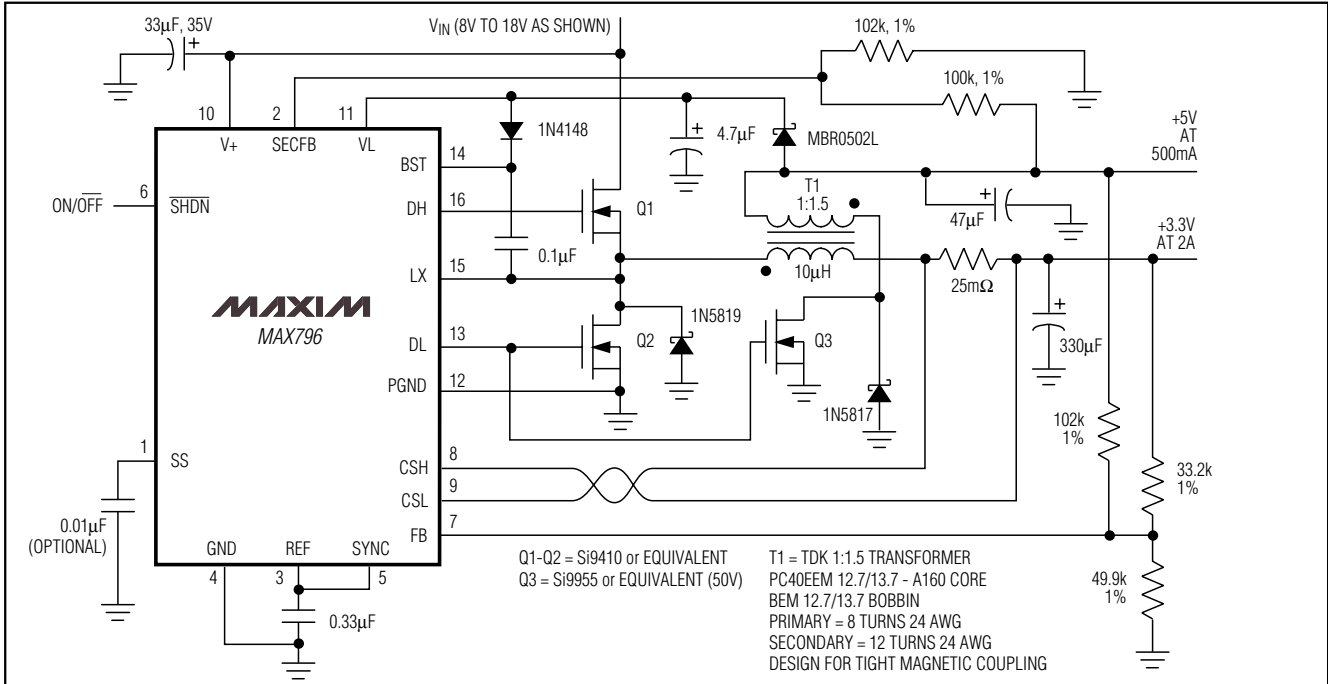

Figure 12. +3.3V/+5V Dual-Output Application (MAX796)

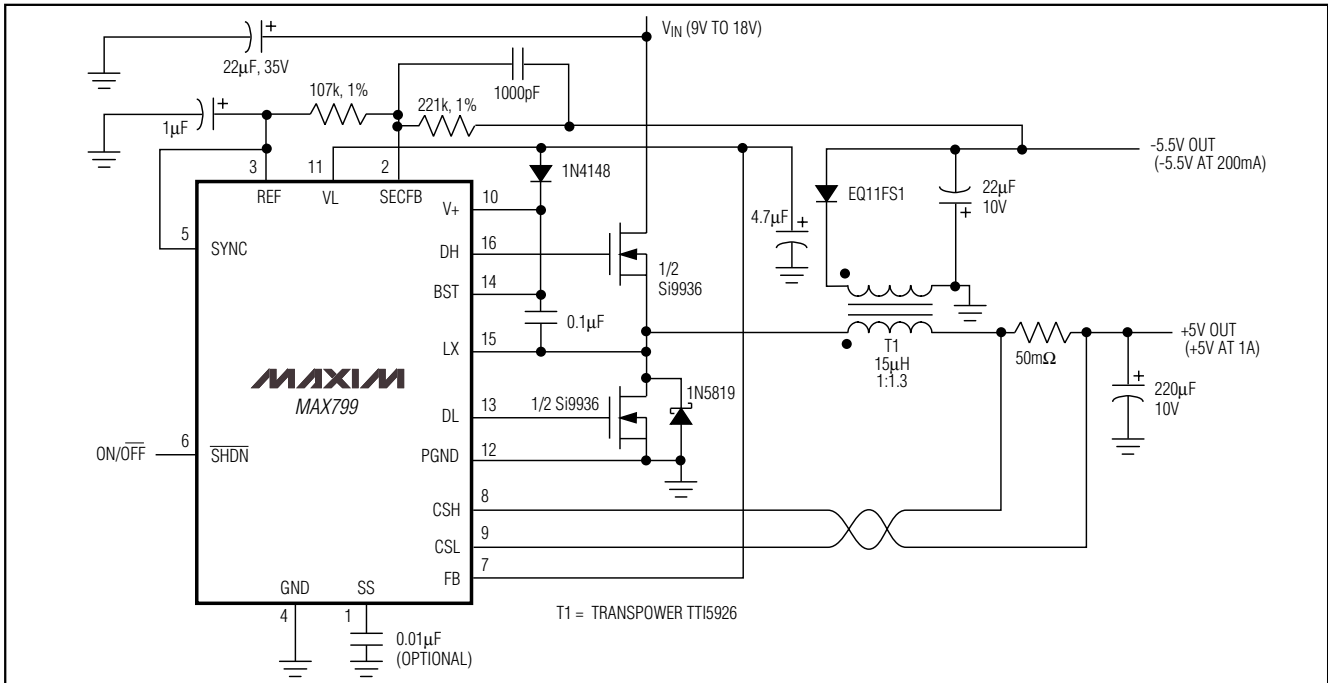

Figure 13. \pm 5V Dual-Output Application (MAX799)

Step-Down Controllers with Synchronous Rectifier for CPU Power

Application Circuits (continued)

MAX796/MAX797/MAX799

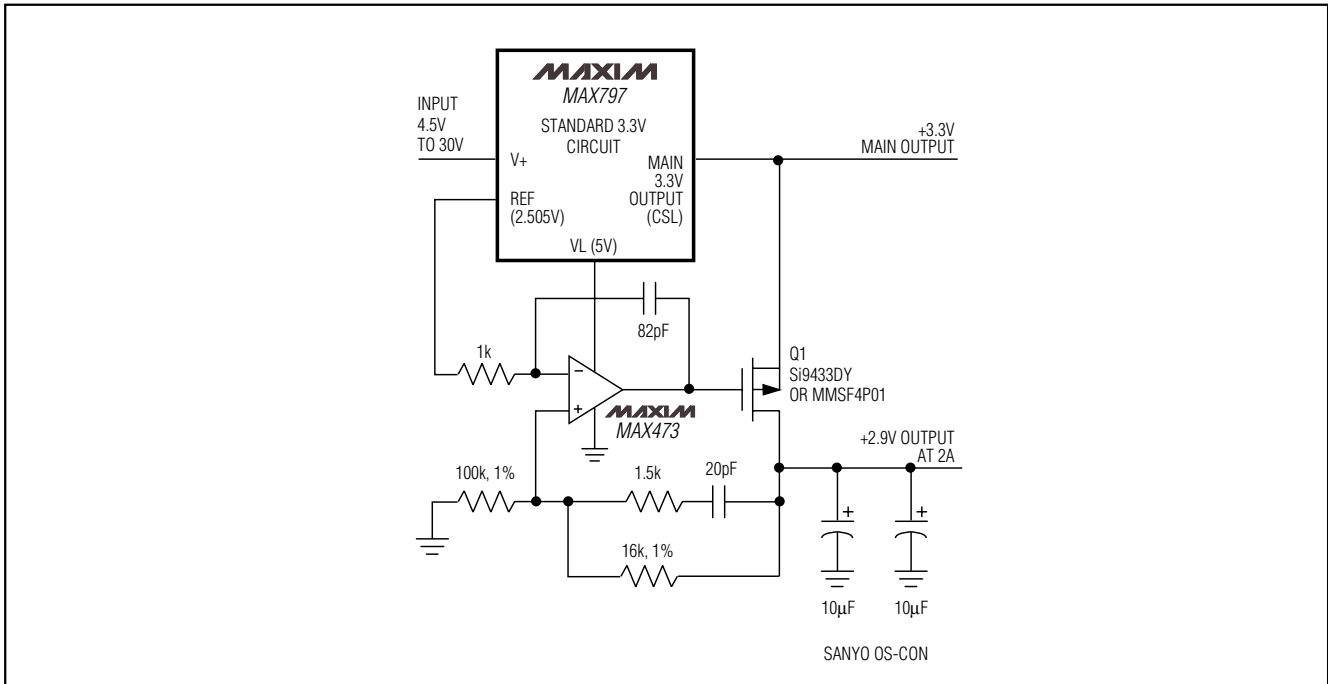

Figure 14. 2.9V Low-Dropout Linear Regulator with Fast Transient Response

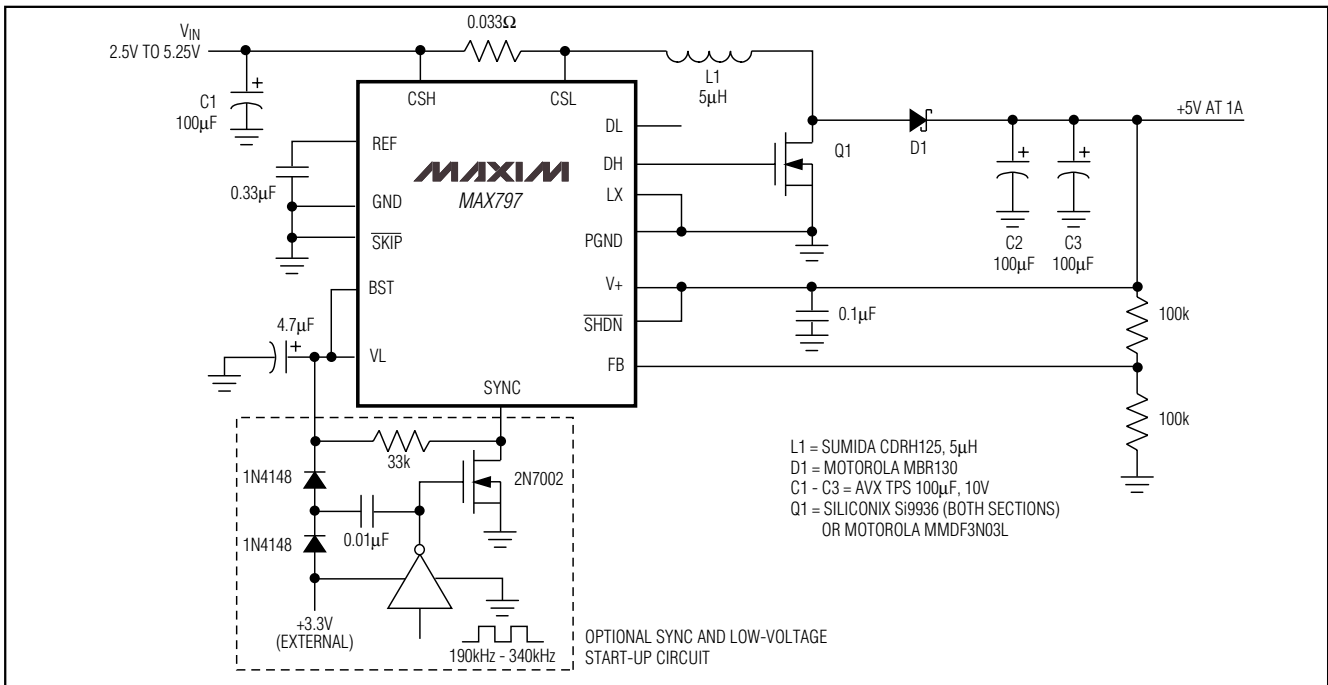

Figure 15. Low-Noise Boost Converter for Cellular Phones

Step-Down Controllers with Synchronous Rectifier for CPU Power

Application Circuits (continued)

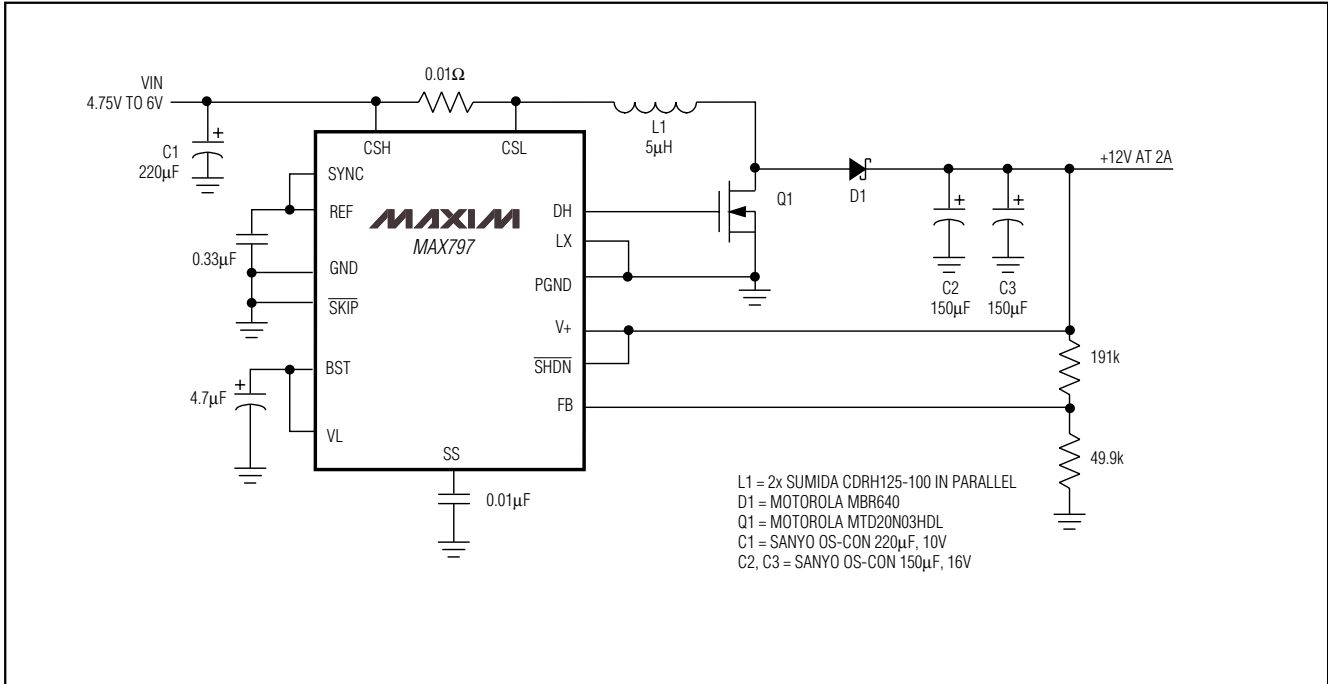

Figure 16. 5V-to-12V PWM Boost Converter

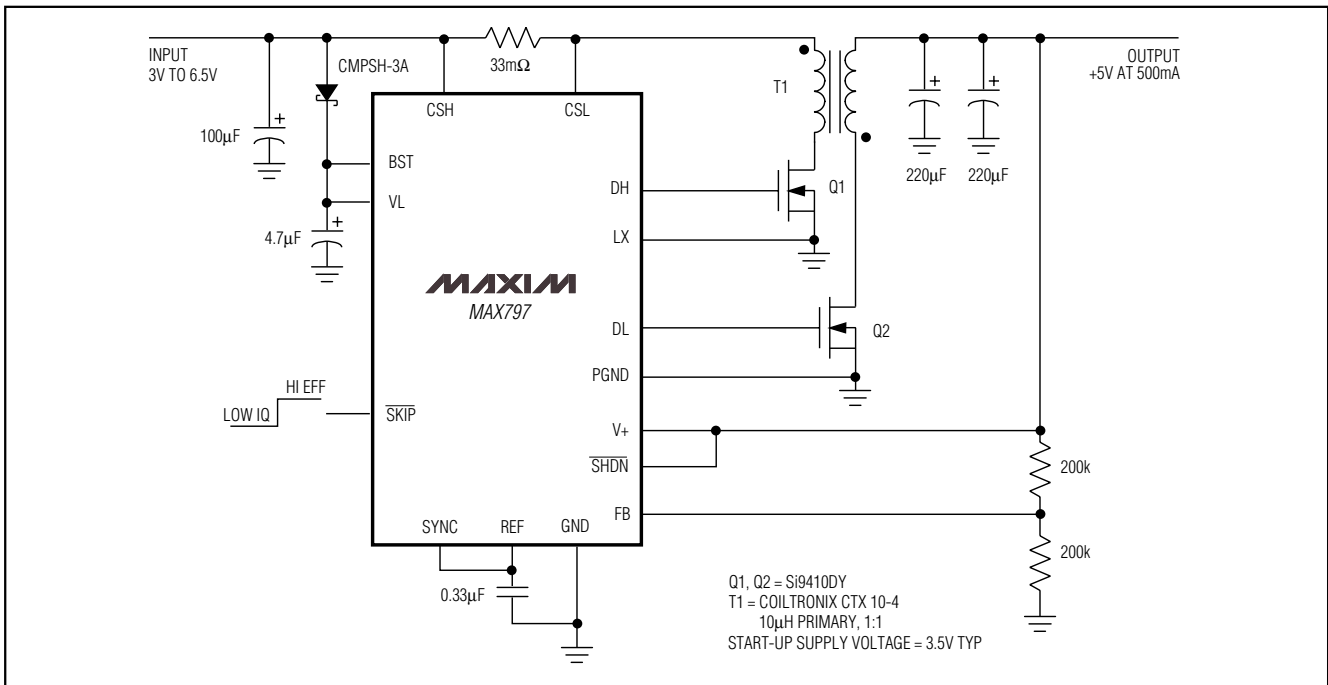

Figure 17. 90% Efficient, Low-Voltage PWM Flyback Converter (4 Cells to 5V)

Step-Down Controllers with Synchronous Rectifier for CPU Power

Application Circuits (continued)

MAX796/MAX797/MAX799

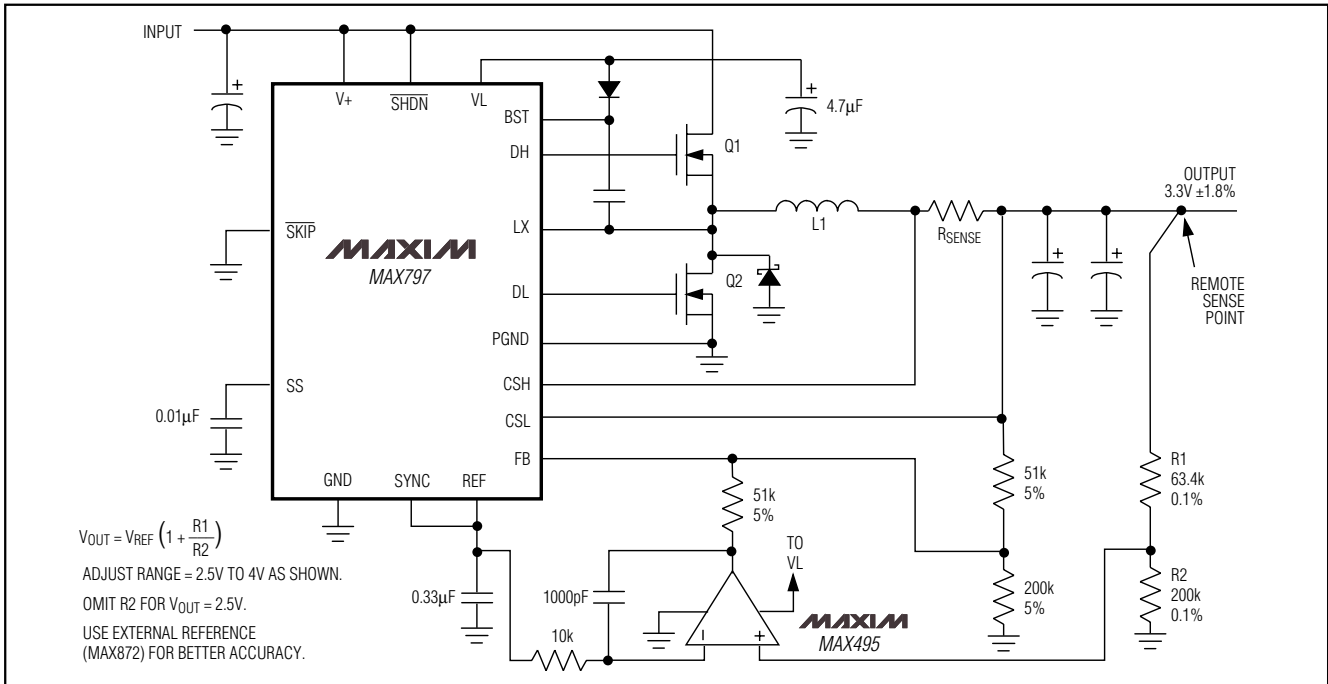

Figure 18. High-Accuracy Adjustable-Output Application

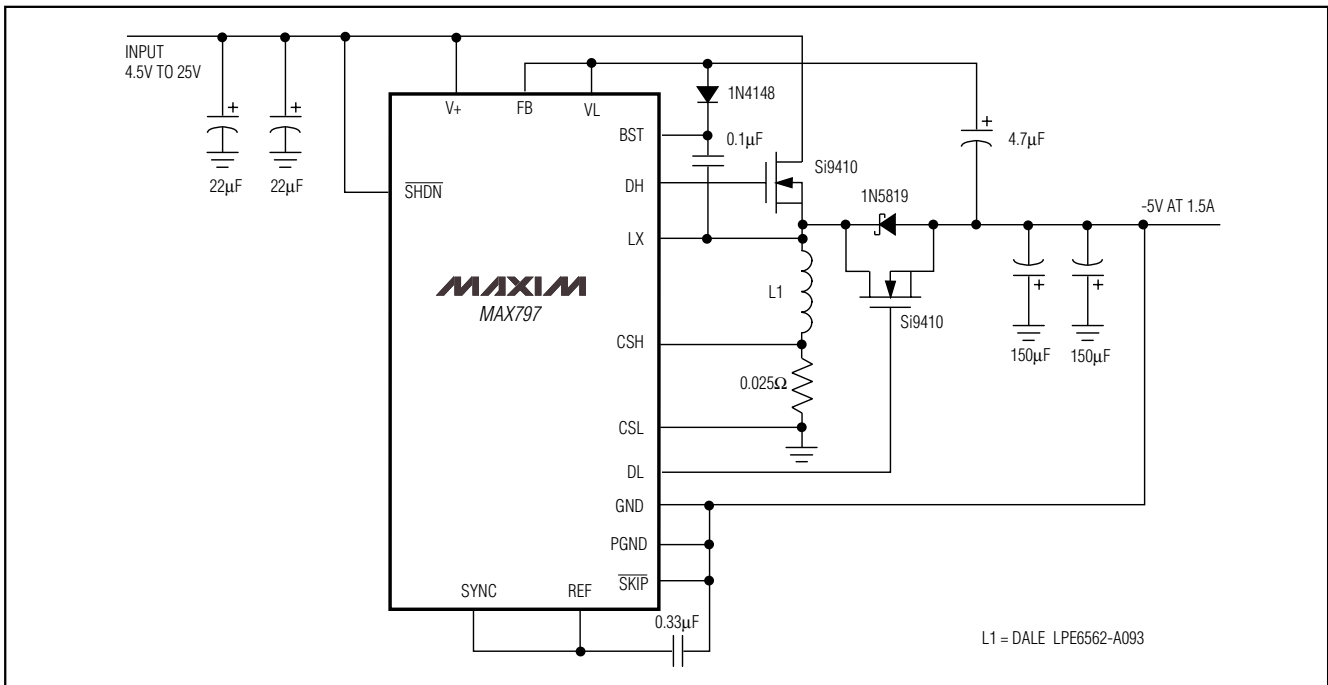

Figure 19. Negative-Output (Inverting Topology) Power Supply

Step-Down Controllers with Synchronous Rectifier for CPU Power

Application Circuits (continued)

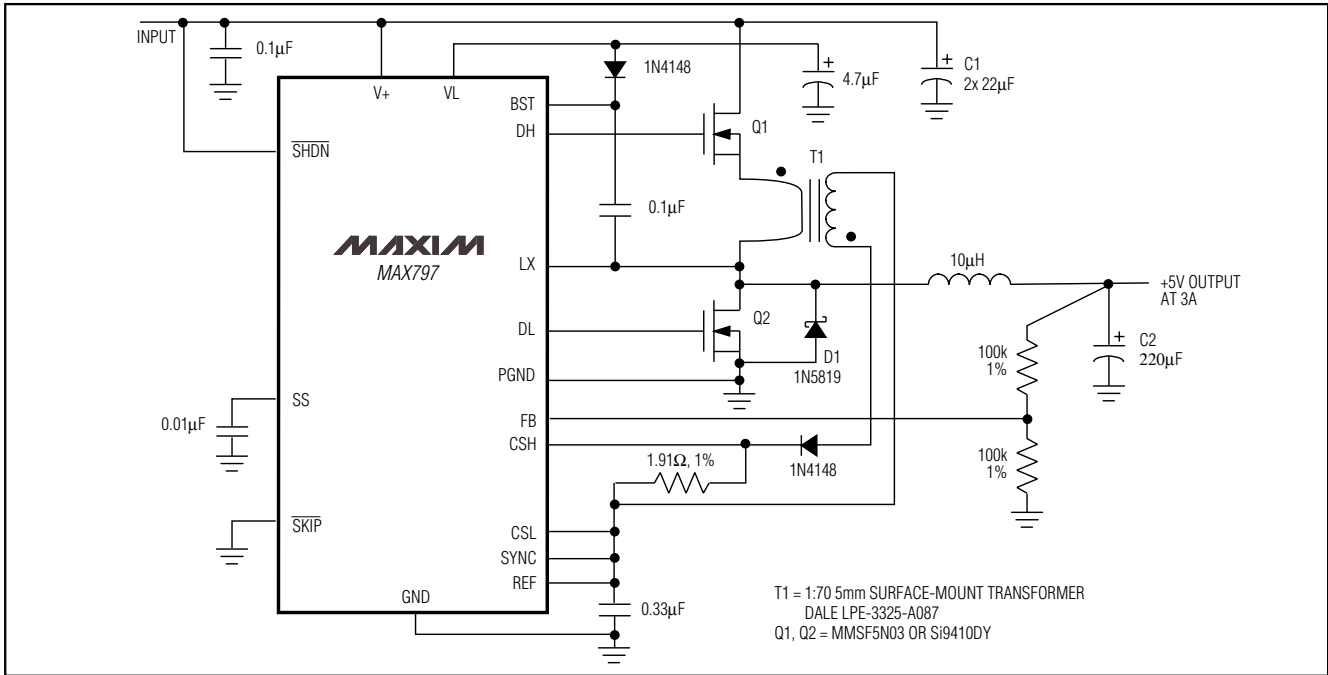

Figure 20. Buck Converter with Low-Loss SMT Current-Sense Transformer

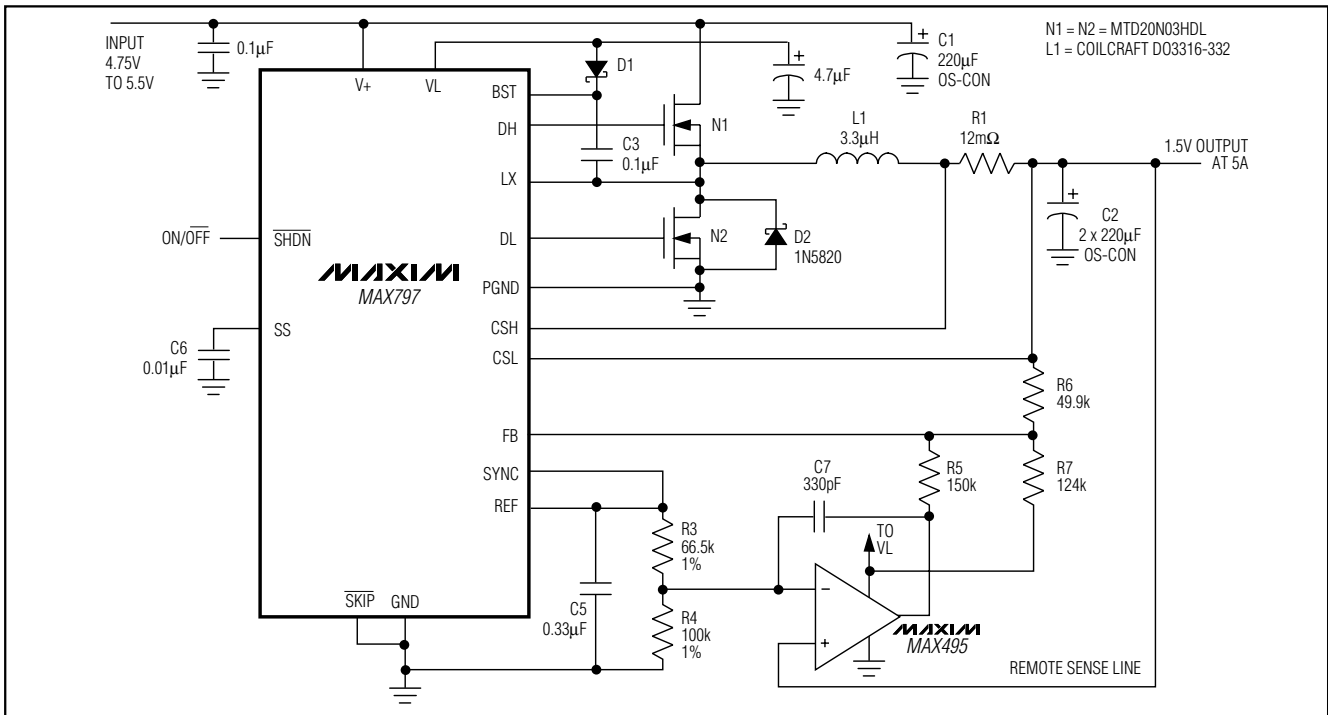

Figure 21. 1.5V GTL Bus Termination Supply

Step-Down Controllers with Synchronous Rectifier for CPU Power

Application Circuits (continued)

MAX796/MAX797/MAX799

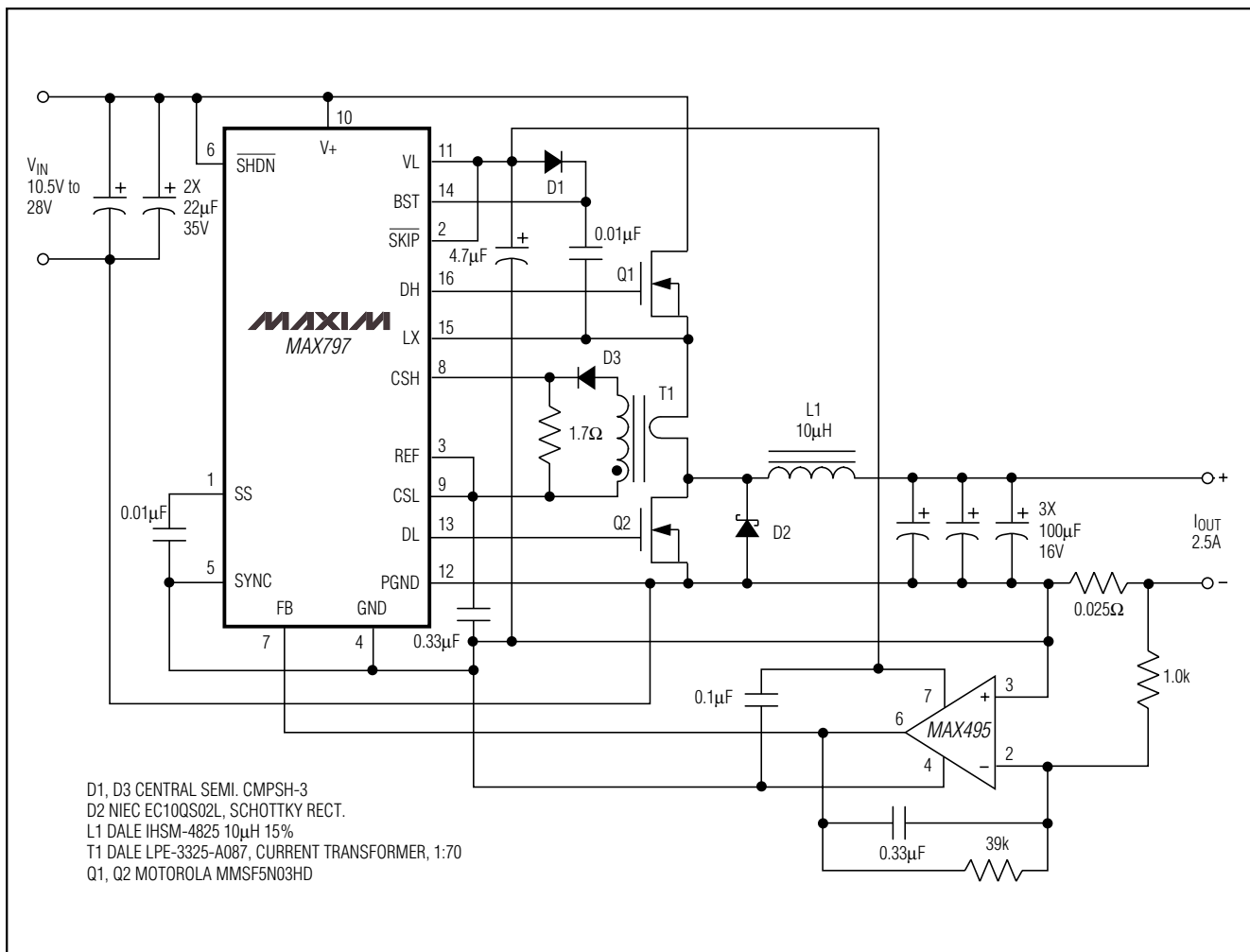

Figure 22. Battery-Charger Current Source

Step-Down Controllers with Synchronous Rectifier for CPU Power

Ordering Information (continued)

PART	TEMP RANGE	PIN-PACKAGE
MAX797CPE	0°C to +70°C	16 Plastic DIP
MAX797CPE+	0°C to +70°C	16 Plastic DIP
MAX797CSE	0°C to +70°C	16 Narrow SO
MAX797CSE+	0°C to +70°C	16 Narrow SO
MAX797C/D	0°C to +70°C	Dice*
MAX797C/D+	0°C to +70°C	Dice*
MAX797EPE	-40°C to +85°C	16 Plastic DIP
MAX797EPE+	-40°C to +85°C	16 Plastic DIP
MAX797ESE	-40°C to +85°C	16 Narrow SO
MAX797ESE+	-40°C to +85°C	16 Narrow SO
MAX797MJE	-55°C to +125°C	16 CERDIP
MAX797MJE+	-55°C to +125°C	16 CERDIP
MAX799CPE	0°C to +70°C	16 Plastic DIP
MAX799CSE	0°C to +70°C	16 Narrow SO
MAX799C/D	0°C to +70°C	Dice*
MAX799EPE	-40°C to +85°C	16 Plastic DIP
MAX799ESE	-40°C to +85°C	16 Narrow SO
MAX799MJE	-55°C to +125°C	16 CERDIP

*Contact factory for dice specifications.

Chip Topography

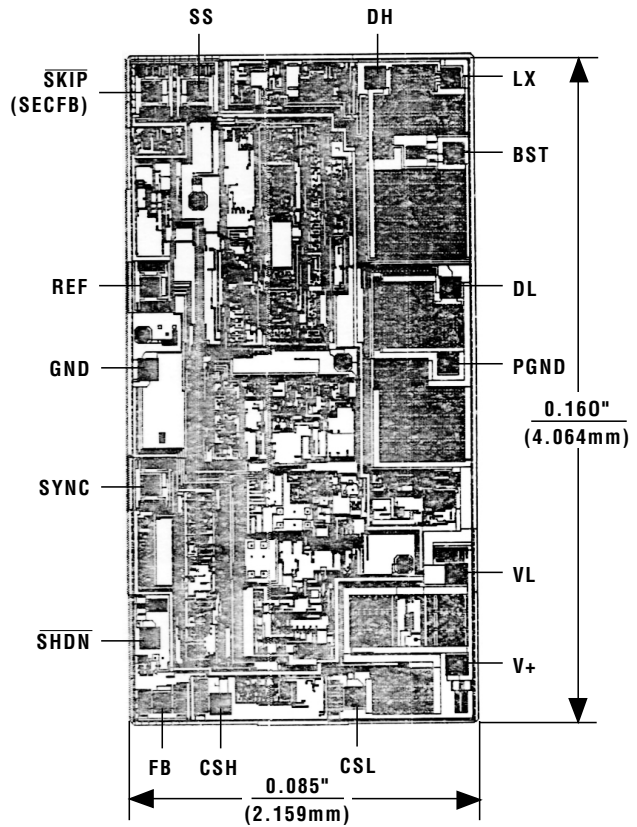

() ARE FOR MAX796/MAX799 ONLY.

TRANSISTOR COUNT: 913
SUBSTRATE CONNECTED TO GND

Maxim cannot assume responsibility for use of any circuitry other than circuitry entirely embodied in a Maxim product. No circuit patent licenses are implied. Maxim reserves the right to change the circuitry and specifications without notice at any time.

32 **Maxim Integrated Products, 120 San Gabriel Drive, Sunnyvale, CA 94086 (408) 737-7600**

Looking for pricing, stock, or lifecycle information?

Click below to explore more details on WIN SOURCE:

 [View MAX797CSE+T on WIN SOURCE](#)

 [Maxim Integrated](#) Information

Optimize Your Supply Chain with WIN SOURCE Solutions

-  Global Sourcing Solution
-  Obsolete Management
-  Cost Control Management
-  Shortage Management
-  Alternative Solution
-  Excess Inventory Management