



**THE DATASHEET OF
MAX868EUB+**



MAXIM

Regulated, Adjustable -2x Inverting Charge Pump

MAX868

General Description

The MAX868 inverting charge pump provides a low-cost and compact means of generating a regulated negative voltage up to $-2 \times V_{IN}$ from a positive input voltage between 1.8V and 5.5V. It uses a pulse-frequency-modulation (PFM) control scheme to generate the regulated negative output voltage. PFM operation is obtained by gating the internal 450kHz oscillator on and off as needed to maintain output voltage regulation. This unique on-demand switching scheme gives the MAX868 excellent light-load efficiency without degrading its full-load operation (up to 30mA), permitting smaller capacitors to take advantage of the oscillator's high switching frequency.

The MAX868 requires no inductors; only four capacitors are required to build a complete DC-DC converter. Output voltage regulation is achieved by adding just two resistors. The MAX868 comes in a 10-pin μ MAX package, which is only 1.11mm high and occupies just half the board area of a standard 8-pin SO.

Applications

- Small LCD Panels
- Cell Phones
- Cordless Phones
- Camcorders
- Handy-Terminals, PDAs
- Medical Instruments
- Battery-Operated Equipment

Configuration

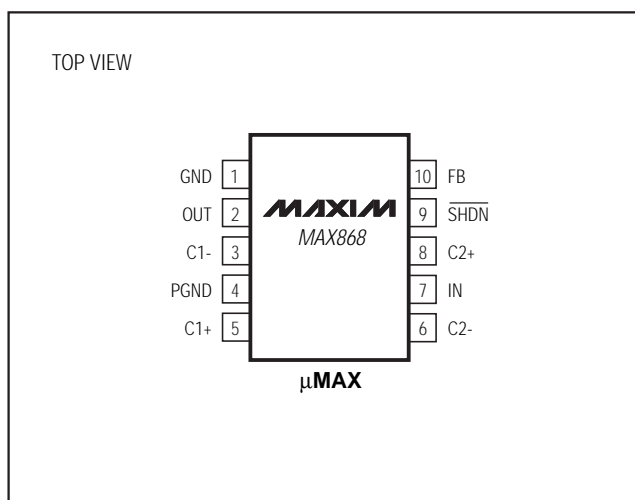

Features

- ◆ Regulated Negative Output Voltage (up to $-2 \times V_{IN}$)
- ◆ Ultra-Small, 10-Pin μ MAX Package
- ◆ On-Demand Switching at up to 450kHz
- ◆ 30 μ A Quiescent Supply Current
- ◆ Requires Only Four Small External Capacitors
- ◆ 1.8V to 5.5V Input Voltage Range
- ◆ 0.1 μ A Logic-Controlled Shutdown
- ◆ Up to 30mA Output Current

Ordering Information

PART	TEMP. RANGE	PIN-PACKAGE
MAX868C/D	0°C to +70°C	Dice*
MAX868EUB	-40°C to +85°C	10 μ MAX

*Dice are tested at $T_A = +25^\circ\text{C}$.

Typical Operating Circuit

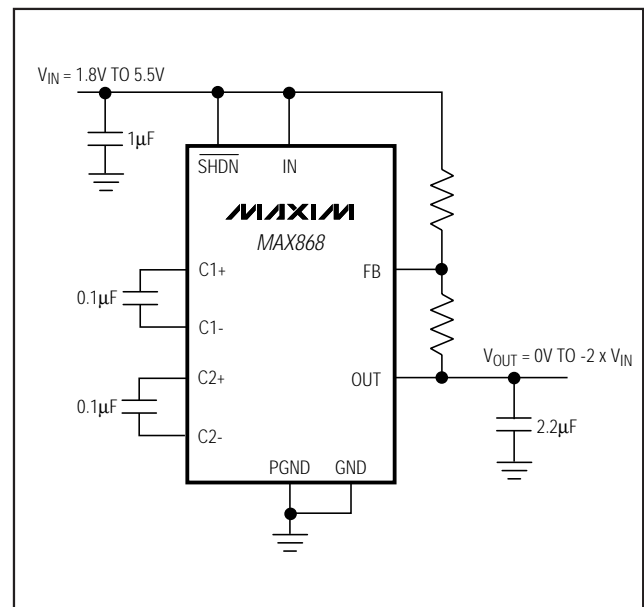

MAXIM

Maxim Integrated Products 1

For free samples & the latest literature: <http://www.maxim-ic.com>, or phone 1-800-998-8800.
For small orders, phone 408-737-7600 ext. 3468.

Regulated, Adjustable -2x Inverting Charge Pump

ABSOLUTE MAXIMUM RATINGS

IN to GND	-0.3V to +6V	Output Current	35mA
OUT to GND	+0.3V to -12V	Short-Circuit Duration	Continuous
IN to OUT	-0.3V to -17V	Continuous Power Dissipation ($T_A = +70^\circ\text{C}$)	
C1+ to GND	$(V_{IN} - 12\text{V})$ to $(V_{IN} + 0.3\text{V})$	10-pin μMAX (derate 5.6mW/ $^\circ\text{C}$ above $+70^\circ\text{C}$)	444mW
C1- to GND	+0.3V to -12V	Operating Temperature Range	
C2+ to GND	$(V_{IN} + 0.3\text{V})$ to -6V	MAX868EUB	-40 $^\circ\text{C}$ to +85 $^\circ\text{C}$
C2- to GND	+0.3V to -6V	Storage Temperature Range	-65 $^\circ\text{C}$ to +160 $^\circ\text{C}$
SHDN, FB to GND	-0.3V to $(V_{IN} + 0.3\text{V})$	Lead Temperature (soldering, 10sec)	+300 $^\circ\text{C}$
PGND to GND	-0.3V to +0.3V		

Stresses beyond those listed under "Absolute Maximum Ratings" may cause permanent damage to the device. These are stress ratings only, and functional operation of the device at these or any other conditions beyond those indicated in the operational sections of the specifications is not implied. Exposure to absolute maximum rating conditions for extended periods may affect device reliability.

ELECTRICAL CHARACTERISTICS

($V_{IN} = +3.3\text{V}$, $\overline{\text{SHDN}} = \text{IN}$, $C1 = C2 = 0.22\mu\text{F}$, $C_{IN} = 1\mu\text{F}$, $C_{OUT} = 10\mu\text{F}$, $T_A = 0^\circ\text{C}$ to $+85^\circ\text{C}$, unless otherwise noted. Typical values are at $T_A = +25^\circ\text{C}$.)

PARAMETER	SYMBOL	CONDITIONS		MIN	TYP	MAX	UNITS
Supply-Voltage Range	V_{IN}	$R_L = 3\text{k}\Omega$ to GND		1.8		5.5	V
Supply Current	I_{IN}	No load, $V_{FB} = -50\text{mV}$			30	50	μA
		FB = IN			5		mA
Shutdown Current	$I_{IN,SHDN}$	No load, $\overline{\text{SHDN}} = \text{GND}$			0.1	1	μA
Oscillator Frequency	f_{OSC}	$V_{FB} = 50\text{mV}$	$T_A = +25^\circ\text{C}$	293	450	607	kHz
			$T_A = 0^\circ\text{C}$ to $+85^\circ\text{C}$	270		630	
Closed-Loop Output Resistance	$R_{OUT,CL}$	$V_{OUT} = -5\text{V}$			0.2		Ω
Open-Loop Output Resistance	R_{OUT}	$I_{OUT} = 5\text{mA}$, FB = IN	$T_A = +25^\circ\text{C}$		70	100	Ω
			$T_A = 0^\circ\text{C}$ to $+85^\circ\text{C}$			125	
		$\overline{\text{SHDN}} = \text{GND}$ (OUT pulls to GND)			15	50	
FB Trip Point		$V_{IN} = 1.8\text{V}$ to 5.5V	$T_A = +25^\circ\text{C}$	-30		30	mV
			$T_A = 0^\circ\text{C}$ to $+85^\circ\text{C}$	-40		40	mV
Output Current	I_{OUT}	Closed loop	$V_{IN} = 3.3\text{V}$, $V_{OUT} = -5\text{V}$		12		mA
			$V_{IN} = 5\text{V}$, $V_{OUT} = -3.3\text{V}$		30		
FB Input Bias Current		$V_{IN} = 1.8\text{V}$ to 5.5V , $T_A = +25^\circ\text{C}$		-50	1	50	nA
$\overline{\text{SHDN}}$ Input Threshold	V_{IL}	$V_{IN} = 1.8\text{V}$ to 5.5V		0.3 V_{IN}			V
	V_{IH}			0.7 V_{IN}			
$\overline{\text{SHDN}}$ Input Bias Current		$V_{IN} = 5.5\text{V}$, $\overline{\text{SHDN}} = \text{IN}$ or GND		-100	1	100	nA

Regulated, Adjustable -2x Inverting Charge Pump

MAX868

ELECTRICAL CHARACTERISTICS

($V_{IN} = +3.3V$, $C1 = C2 = 0.22\mu F$, $C_{IN} = 1\mu F$, $C_{OUT} = 10\mu F$, $T_A = -40^{\circ}C$ to $+85^{\circ}C$, unless otherwise noted. (Note 1))

PARAMETER	SYMBOL	CONDITIONS	MIN	TYP	MAX	UNITS
Supply-Voltage Range	V_{IN}	$R_L = 3k\Omega$ to GND	1.8		5.5	V
Supply Current	I_{IN}	No load, $V_{FB} = -50mV$			55	μA
Shutdown Current	$I_{IN,SHDN}$	No load, $\overline{SHDN} = GND$			1	μA
Oscillator Frequency	f_{OSC}	$V_{FB} = 50mV$	270		630	kHz
Open-Loop Output Resistance	R_{OUT}	$I_{OUT} = 5mA$, $FB = IN$			125	Ω
		$\overline{SHDN} = GND$ (OUT pulls to GND)			50	
FB Trip Point		$V_{IN} = 1.8V$ to $5.5V$	-40		40	mV
FB Input Bias Current		$V_{IN} = 1.8V$ to $5.5V$	-100		100	nA
\overline{SHDN} Input Threshold	V_{IL}	$V_{IN} = 1.8V$ to $5.5V$	0.3 V_{IN}			V
	V_{IH}		0.7 V_{IN}			
\overline{SHDN} Input Bias Current		$V_{IN} = 5.5V$, $\overline{SHDN} = IN$ or GND	-100		100	nA

Note 1: Specifications to $-40^{\circ}C$ are guaranteed by design, not production tested.

Typical Operating Characteristics

(Circuit of Figure 5, $T_A = +25^{\circ}C$, unless otherwise noted.)

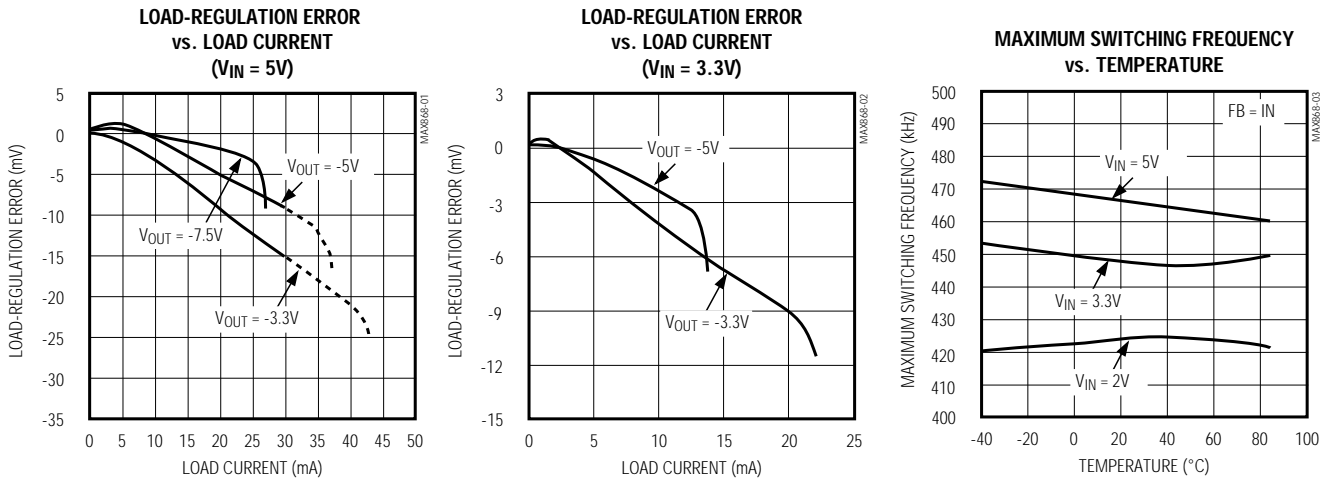

Regulated, Adjustable -2x Inverting Charge Pump

Typical Operating Characteristics (continued)

(Circuit of Figure 5, $T_A = +25^\circ\text{C}$, unless otherwise noted.)

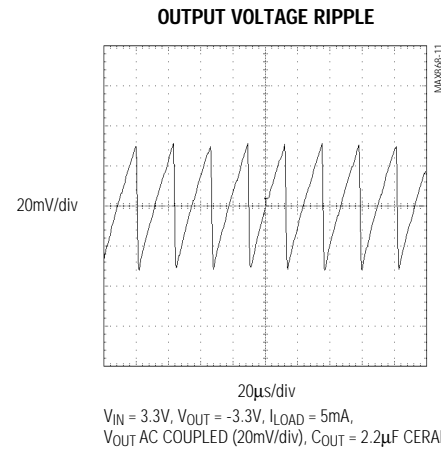
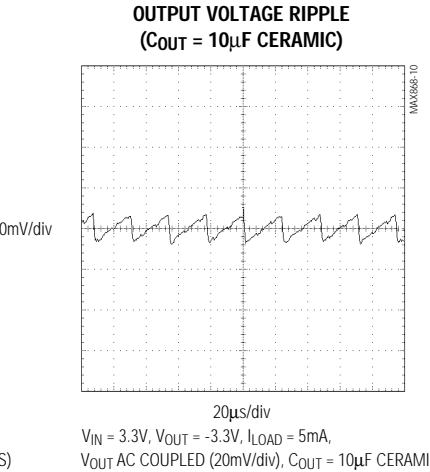
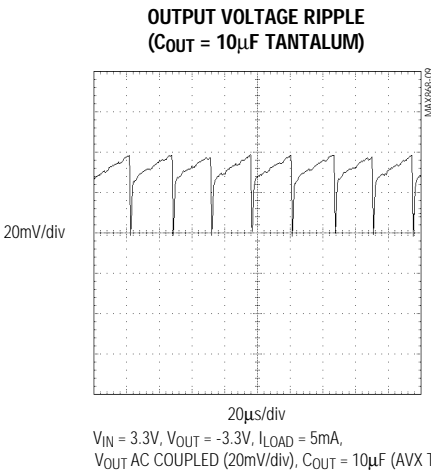
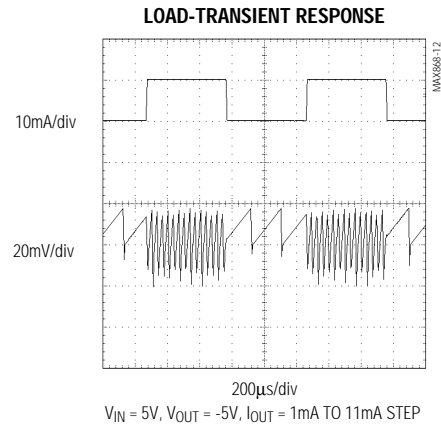
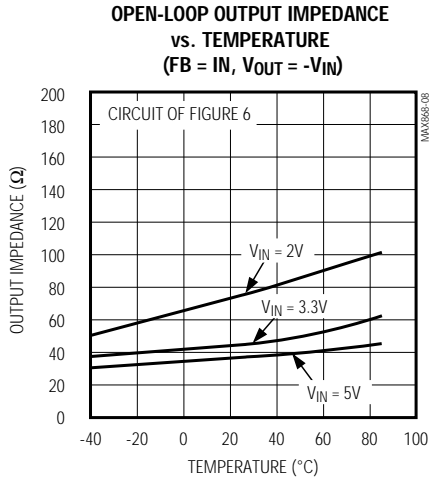
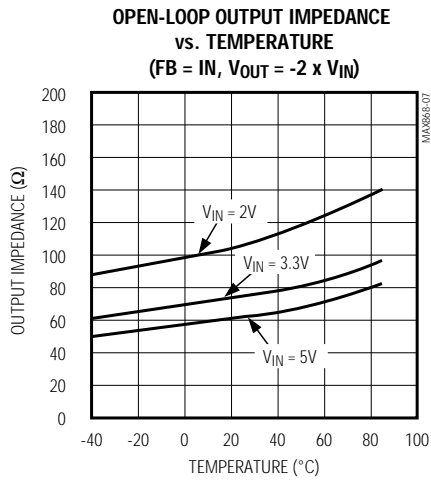
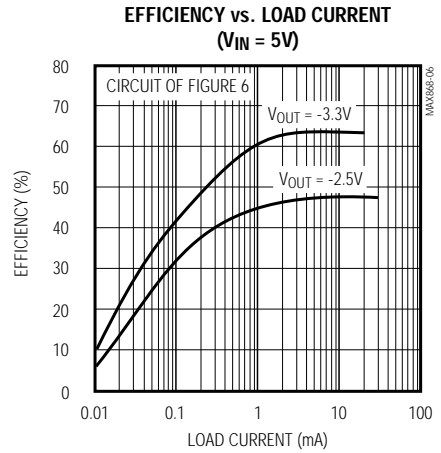
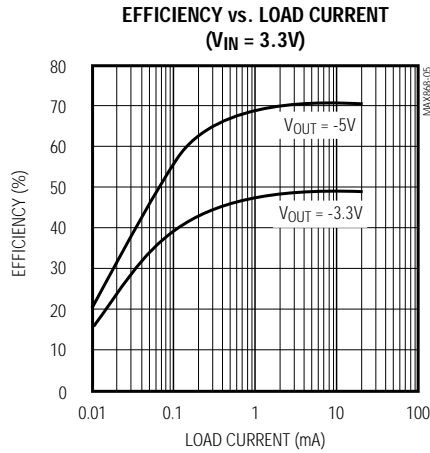
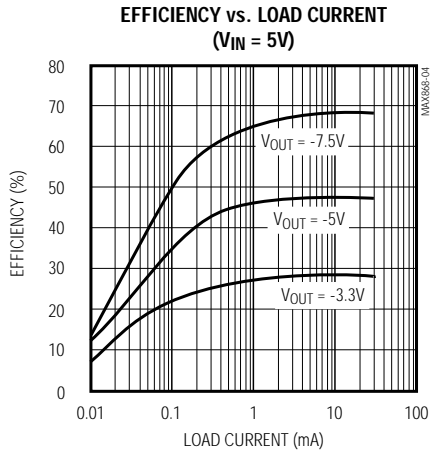

Regulated, Adjustable -2x Inverting Charge Pump

MAX868

Pin Description

PIN	NAME	FUNCTION
1	GND	Analog Ground
2	OUT	Charge-Pump Output
3	C1-	Negative Terminal of Flying Capacitor C1
4	PGND	Power Ground
5	C1+	Positive Terminal of Flying Capacitor C1
6	C2-	Negative Terminal of Flying Capacitor C2
7	IN	Supply-Voltage Input. Input voltage range is 1.8V to 5.5V.
8	C2+	Positive Terminal of Flying Capacitor C2
9	$\overline{\text{SHDN}}$	Active-Low Shutdown Input. Connect $\overline{\text{SHDN}}$ to GND to put the MAX868 in shutdown mode and reduce supply current to 0.1 μA . Connect to IN for normal operation. OUT is actively pulled to GND in shutdown.
10	FB	Feedback Input. Connect FB to a resistor divider for a regulated output voltage. Connect to IN to generate an unregulated -2 x V_{IN} output voltage.

Detailed Description

The MAX868 inverting charge pump uses pulse-frequency-modulation (PFM) control to generate a regulated negative output voltage up to $-2 \times V_{\text{IN}}$. PFM operation is obtained by enabling the internal 450kHz oscillator as needed to maintain output voltage regulation. This control scheme reduces supply current at light loads and permits the use of small capacitors.

The functional diagram shown in Figure 1 indicates the two phases of MAX868 operation: charge phase ($\Phi 1$) and discharge phase ($\Phi 2$). In charge phase, the switches on the left-hand side close, and the switches on the right-hand side open. In the discharge phase, the inverse occurs.

Figure 2 illustrates that in charge phase, both flying capacitors are charged in parallel. The load is serviced entirely by the charge stored in the output capacitor. Figure 3 demonstrates the series connection of the flying capacitors in the discharge phase. The series combination of the flying capacitors, when connected to the output capacitor, transfers charge to the output in order to maintain output voltage regulation. In normal operation, the MAX868 operates predominantly in charge phase, switching to discharge phase only as needed to maintain a regulated output.

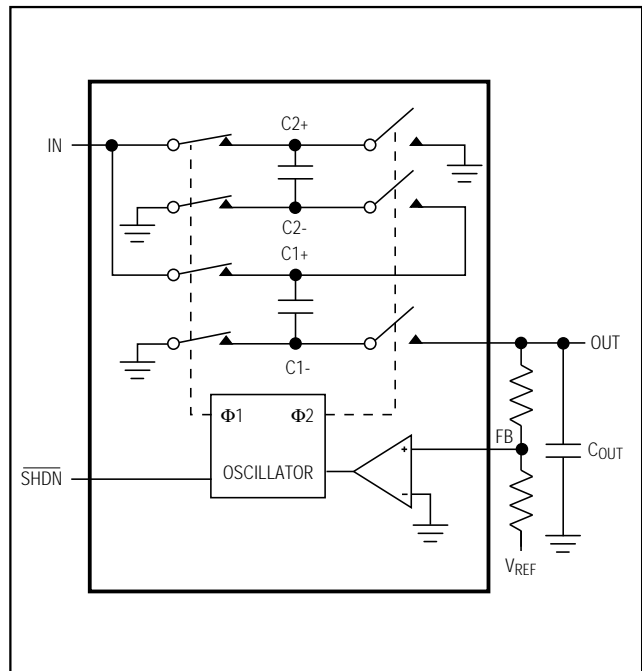

Figure 1. Functional Diagram

Regulated, Adjustable -2x Inverting Charge Pump

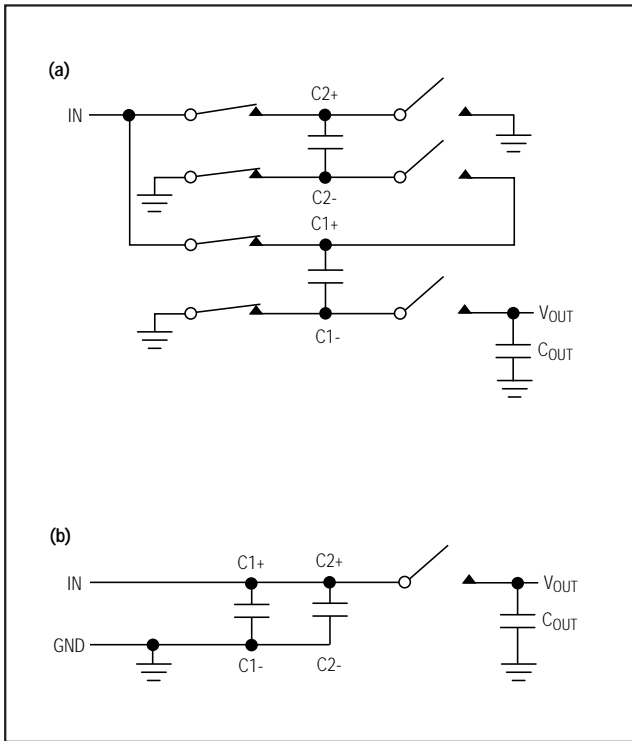

Figure 2. **a)** In charge phase, the left-hand switches are closed and the right-hand switches are open, charging the flying capacitors (C1 and C2) while the output capacitor (C_{OUT}) services the load. **b)** The equivalent circuit of the charge phase of operation.

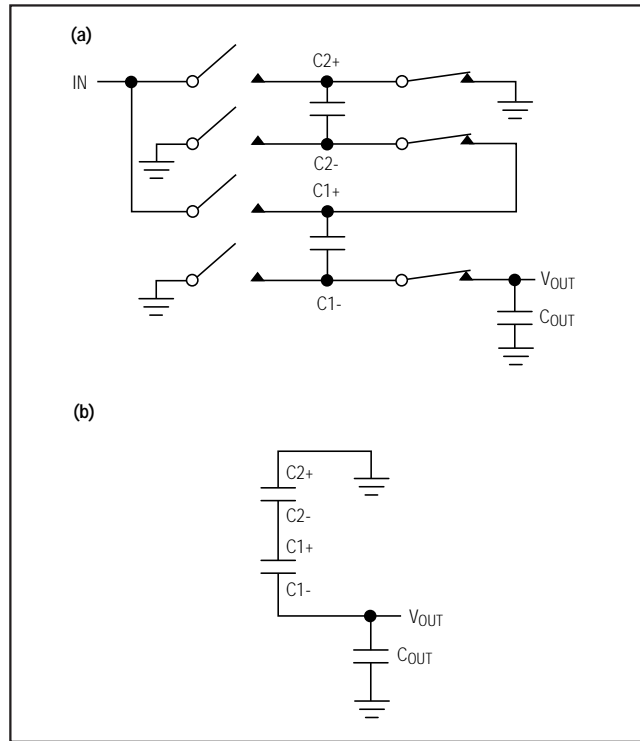

Figure 3. **a)** In discharge phase, the left-hand switches are open and the right-hand switches are closed, transferring energy from the flying capacitors (C1 and C2) to the output capacitor (C_{OUT}). **b)** The equivalent circuit of the discharge phase of operation.

Design Procedure

Setting the Output Voltage

Set the output voltage using two external resistors, R1 and R2, as shown in Figure 4. Since the input bias current at FB has a 50nA maximum, large resistor values in the feedback loop do not significantly degrade accuracy. Begin by selecting R2 in the 100kΩ to 500kΩ range, and calculate R1 using the following equation:

$$R1 = R2 \times \frac{|V_{OUT}|}{V_{REF}}$$

where V_{OUT} is the desired output voltage, and V_{REF} is any available regulated positive voltage. When the MAX868 is powered by a regulated voltage, V_{IN} can be used as the reference for setting the output voltage.

When the MAX868 is powered by an unregulated supply, such as when operating directly from a battery, use any available positive reference voltage in the system. Note that due to the MAX868's doubling and inverting charge-pump action, the output voltage is limited to -2 x V_{IN}.

Alternatively, to configure the MAX868 as a simple, unregulated doubler-inverter (V_{OUT} = -2 x V_{IN}), connect FB to IN. In this configuration, the MAX868 runs at its maximum oscillator frequency, operating as a conventional, open-loop charge pump.

If multiple oscillator cycles are required to regulate the output, reduce the values for R1 and R2, or parallel a small capacitor (C_C) across R1 to compensate the feedback loop and ensure stability. Choose the lowest capacitor value that ensures stability; values up to 47pF are adequate for most applications.

Regulated, Adjustable -2x Inverting Charge Pump

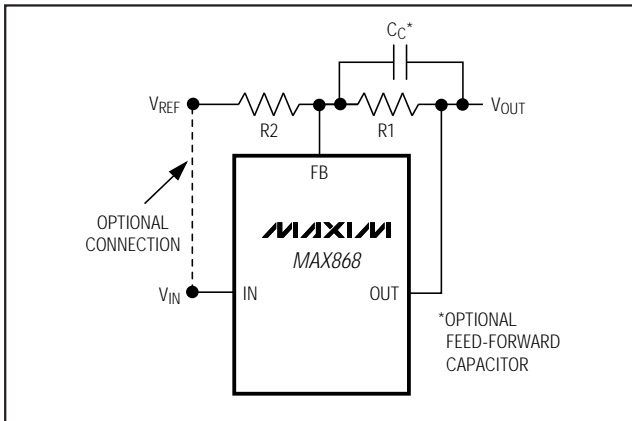

Figure 4. Setting the Output Voltage Using Two External Resistors

Capacitor Selection

Choosing the Flying Capacitors

Proper choice of the flying capacitors is dependent primarily upon the desired output current. For flying capacitors in the 0.1µF to 0.33µF range, the maximum output current can be approximated by the following equation:

$$I_{OUT(MAX)} = \frac{2 \times V_{IN} - |V_{OUT}|}{\frac{4}{f_{MAX} \times (C1 + C2)} + R_{OUT} \times \frac{10V}{V_{IN} + |V_{OUT}|}}$$

where f_{MAX} is the maximum oscillator frequency (typically 450kHz), R_{OUT} is the MAX868 open-loop output impedance (typically 70Ω), and C1 and C2 are the flying-capacitor values. As a general rule, choose the lowest-value flying capacitors that provide the desired output current in order to minimize output voltage ripple (see the section *Choosing the Output Capacitor*).

Surface-mount ceramic capacitors are preferred, due to their small size, low cost, and low equivalent series resistance (ESR). To ensure proper operation over the entire temperature range, choose ceramic capacitors with X7R (or equivalent) low temperature-coefficient (tempco) dielectrics. See Table 1 for a list of suggested capacitor suppliers.

Choosing the Output Capacitor

The output capacitor stores the charge transferred from the flying capacitors and services the load between oscillator cycles. A good general rule is to make the output capacitance at least ten times greater than that of the flying capacitors.

The output voltage ripple is dependent upon the capacitance of the flying capacitor and upon the output capacitor's capacitance and ESR. When operating in closed-loop mode (when the MAX868 is generating a regulated output voltage), use the following equation to approximate peak-to-peak output voltage ripple:

$$V_{RIPPLE} = (2 \times V_{IN} - |V_{OUT}|) \times \left(\frac{1}{1 + \frac{4 \times C_{OUT}}{C1 + C2}} + \frac{R_{ESR}}{R_{OUT}} \right)$$

where C1 and C2 are the flying capacitors, R_{ESR} is the output capacitor's ESR, and R_{OUT} is the MAX868's open-loop output impedance, typically 70Ω.

Choose a low-ESR output capacitor for minimum output ripple. Surface-mount ceramic capacitors are preferred for their small size, low cost, and low ESR; low-ESR tantalum electrolytic capacitors are also acceptable. When using a ceramic output capacitor, ensure proper operation over the entire temperature range by choosing a capacitor with X7R (or equivalent) low tempco dielectric. See Table 1 for a list of suggested capacitor suppliers.

Table 1. Manufacturers of Surface-Mount, Low-ESR Capacitors

TYPE	MANUFACTURER	PART	PHONE	FAX
Surface-Mount Tantalum	AVX	TPS series	(803) 946-0690	(803) 626-3123
	Matsuo	267 series	(714) 969-2491	(714) 960-6492
	Sprague	593D, 595D series	(603) 224-1961	(603) 224-1430
Surface-Mount Ceramic	AVX	X7R type	(803) 946-0690	(803) 626-3123
	Matsuo	X7R type	(714) 969-2491	(714) 960-6492

Regulated, Adjustable -2x Inverting Charge Pump

Applications Information

Low-Output-Voltage Operation

Since the difference between the voltage of the series-connected flying capacitors and the output voltage must be dissipated within the device, the MAX868's efficiency is very similar to that of a linear regulator. Estimate efficiency using the following equation:

$$\eta = \frac{|V_{OUT}|}{k \times V_{IN}}$$

where k is a constant equal to 2 for the standard configuration of Figure 5 and equal to 1 for the circuit of Figure 6. This equation's denominator is the voltage resulting from the series connection of the flying capacitors (-2 x V_{IN}, as shown in Figure 3b), while its numerator is simply the regulated output voltage.

For applications in which the output voltage will not be more negative than -|V_{IN}|, the efficiency can be doubled using the circuit of Figure 6, as compared to the circuit of Figure 5. In Figure 6, a single flying capacitor is connected between C2+ and C1-, with C2- and C1+ left

unconnected. Furthermore, doubling the flying capacitor to provide the same flying capacitance as the standard configuration (i.e., setting C_F = C1 + C2) provides the same load-current capability as the standard configuration and reduces the MAX868's open-loop output resistance by a factor of two, due to the reduction in the number of switches in the current path.

Layout and Grounding

Proper layout is important to obtain optimal performance. Connect GND to PGND together using the shortest trace possible, and similarly connect these pins to the ground plane. Mount all capacitors as close to the MAX868 as possible, keeping traces short to minimize parasitics. Keep all connections to the FB pin as short as possible. Specifically, locate R1 and R2 next to FB (Figures 7 and 8). Should it become necessary in the final layout, leave room to parallel a feed-forward capacitor across R1.

Chip Information

TRANSISTOR COUNT: 96

SUBSTRATE CONNECTED TO IN

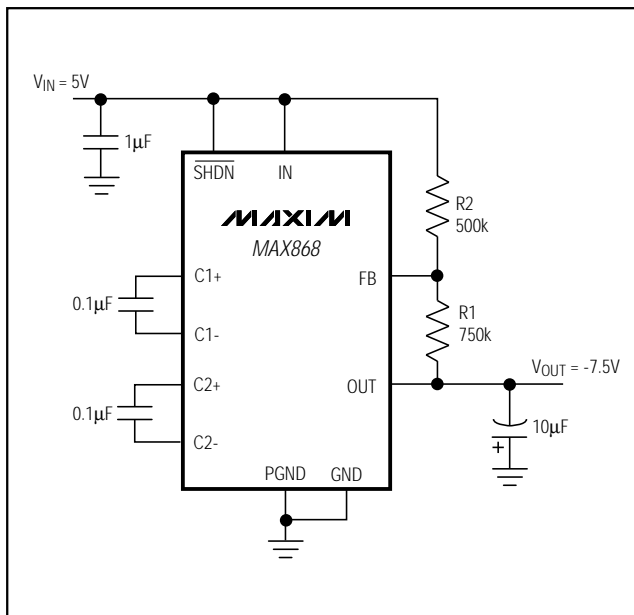

Figure 5. Standard Configuration for Generating an Output Voltage up to -2 x V_{IN}

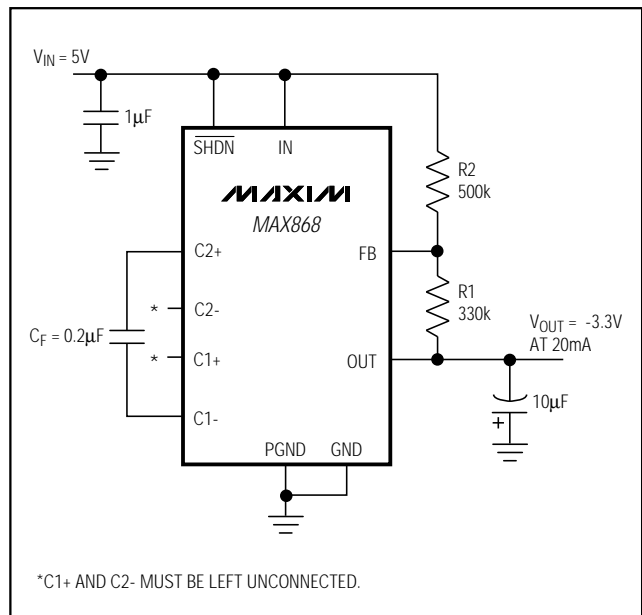

Figure 6. Alternative Configuration for |V_{OUT}| ≤ V_{IN}

*C1+ AND C2- MUST BE LEFT UNCONNECTED.

Regulated, Adjustable -2x Inverting Charge Pump

MAX868

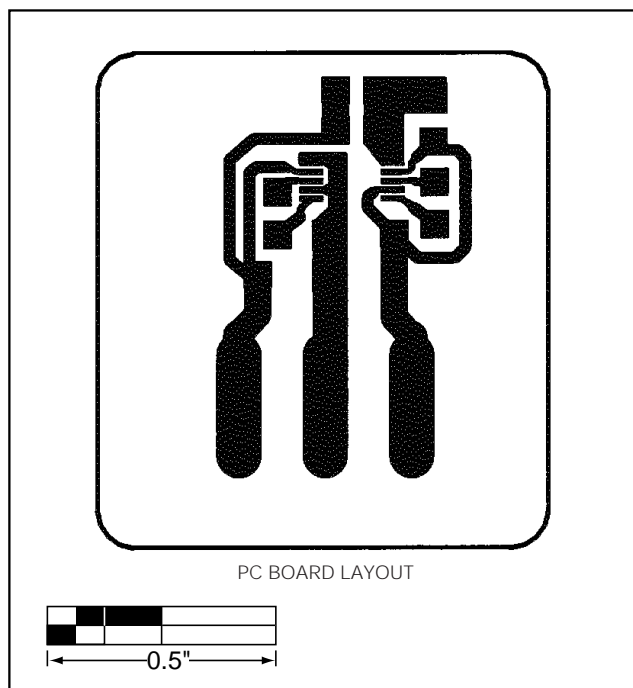
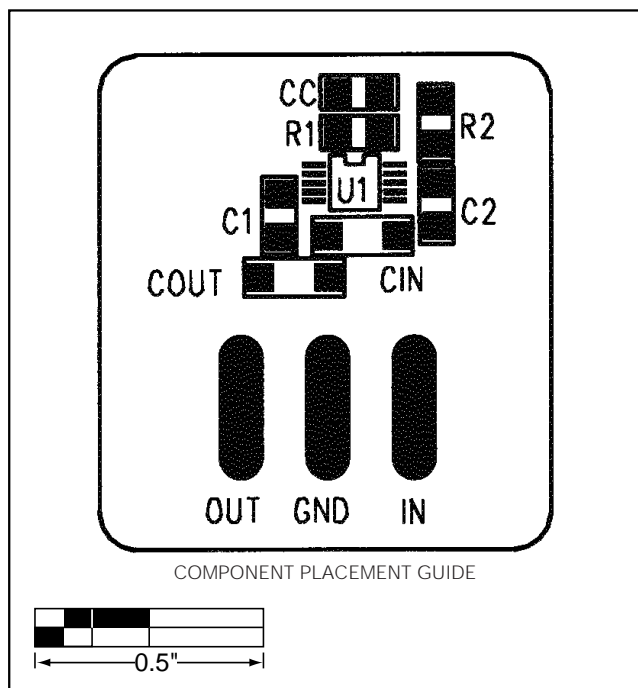

Figure 7a. Suggested Layout for Circuit of Figure 5

Figure 7b. Suggested Layout for Circuit of Figure 5

Regulated, Adjustable -2x Inverting Charge Pump

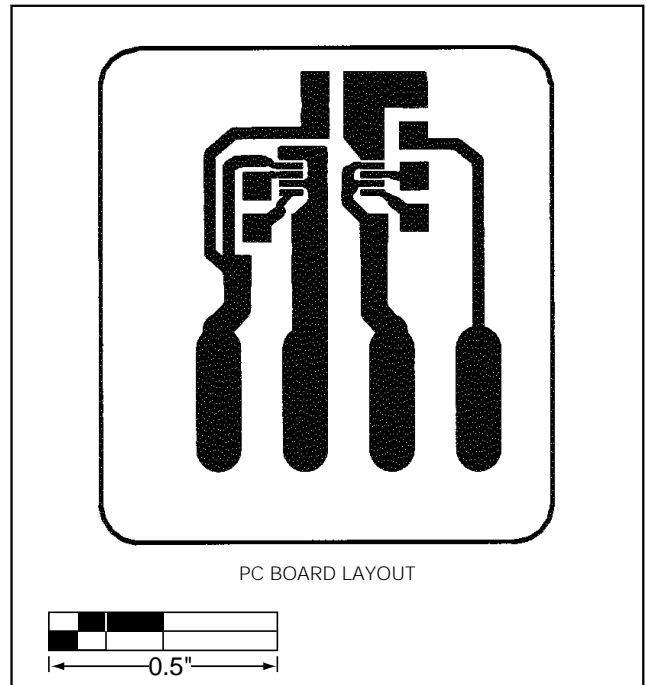
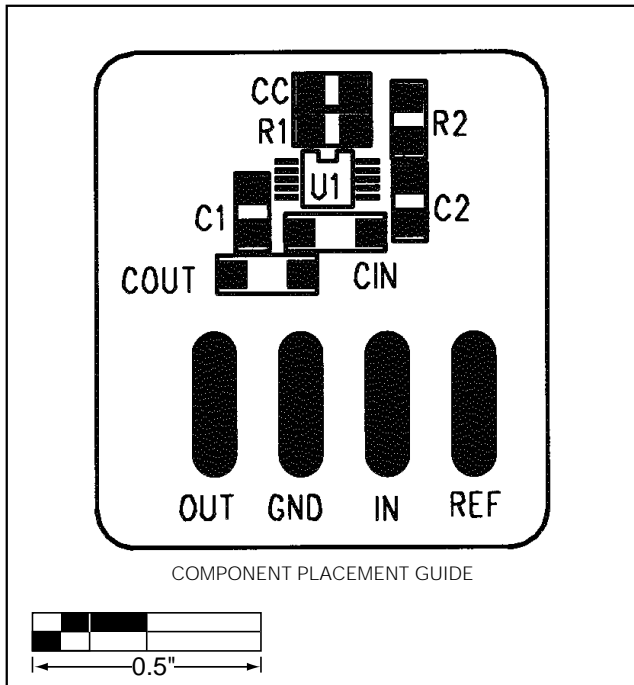

Figure 8a. Suggested Layout for External Reference Applications

Figure 8b. Suggested Layout for External Reference Applications

Regulated, Adjustable -2x Inverting Charge Pump

Package Information

MAX868

10LUMAXB.EPS

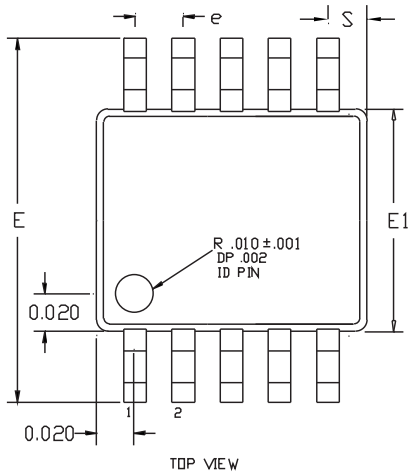

DIM	INCHES		MILLIMETERS	
	MIN	MAX	MIN	MAX
A	0.037	0.043	0.939	1.092
A1	0.002	0.006	0.051	0.152
A2	0.030	0.038	0.762	0.965
D1	0.112	0.124	2.845	3.150
D2	0.110	0.122	2.794	3.099
E1	0.112	0.124	2.845	3.150
E2	0.110	0.122	2.794	3.099
E	0.185	0.201	4.699	5.105
L	0.0155	0.0275	0.394	0.699
L1	0.037	REF	0.940	REF
b	0.007	0.0106	0.177	0.270
e	0.0197 BSC		.500 BSC	
c	0.0035	0.0078	0.090	0.200
S	0.0196	REF	.498	REF
α	0°	6°	0°	6°

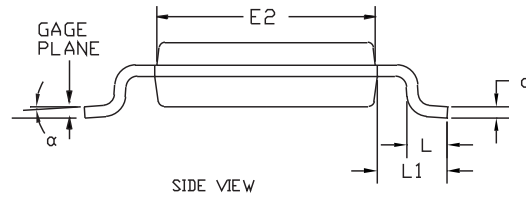
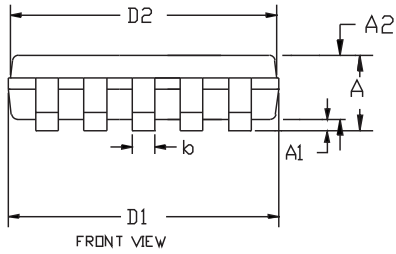

NOTES:

1. D&E DO NOT INCLUDE MOLD FLASH.
2. MOLD FLASH OR PROTRUSIONS NOT TO EXCEED .15mm(.006").
3. CONTROLLING DIMENSION: INCHES

MAXIM			
PROPRIETARY INFORMATION			
TITLE: PACKAGE OUTLINE, 10L MICRO MAX			
APPROVAL:	DOCUMENT CONTROL NO. 21-0061	REV B	1/1

Regulated, Adjustable -2x Inverting Charge Pump

NOTES

Maxim cannot assume responsibility for use of any circuitry other than circuitry entirely embodied in a Maxim product. No circuit patent licenses are implied. Maxim reserves the right to change the circuitry and specifications without notice at any time.

12 _____ Maxim Integrated Products, 120 San Gabriel Drive, Sunnyvale, CA 94086 408-737-7600

Looking for pricing, stock, or lifecycle information?

Click below to explore more details on WIN SOURCE:

 [View MAX868EUB+](#) on WIN SOURCE

 [Maxim Integrated](#) Information

Optimize Your Supply Chain with WIN SOURCE Solutions

-  Global Sourcing Solution
-  Obsolete Management
-  Cost Control Management
-  Shortage Management
-  Alternative Solution
-  Excess Inventory Management