



**THE DATASHEET OF  
MAX8761ETG+T**



**EVALUATION KIT  
AVAILABLE**



# Low-Cost, Linear-Regulator LCD Panel Power Supplies

## General Description

The MAX8710/MAX8711/MAX8712/MAX8761 offer complete linear-regulator power-supply solutions for thin-film transistor (TFT) liquid-crystal-display (LCD) panels used in LCD monitors and LCD TVs. All four devices include a high-performance AVDD linear regulator, a positive charge-pump regulator, a negative charge-pump regulator, and built-in power-up sequence control. The MAX8710/MAX8711/MAX8761 also include a high-current operational amplifier. Additionally, the MAX8710/MAX8761 provide logic-controlled high-voltage switches to control the positive charge-pump output.

The linear regulator directly steps down the input voltage to generate the supply voltage for the source-driver ICs (AVDD). The two built-in charge-pump regulators are used to generate the TFT gate-on and gate-off supplies. The high-current operational amplifier is typically used to drive the LCD backplane (VCOM) and features high output current (150mA), fast slew rate (12V/μs), and wide bandwidth (12MHz). Its rail-to-rail inputs and output maximize flexibility.

The MAX8710/MAX8761 are available in a 24-pin thin QFN package, the MAX8711 is available in a 16-pin thin QFN package, and the MAX8712 is available in a 12-pin thin QFN package. All three packages are 4mm x 4mm with a maximum thickness of 0.8mm for ultra-thin LCD panel design. The MAX8710/MAX8711/MAX8712 operate over the -40°C to +100°C temperature range and the MAX8761 operates over the -40°C to +85°C range.

## Applications

LCD Monitor Panel Modules

LCD TV Panel Modules

## Pin Configurations

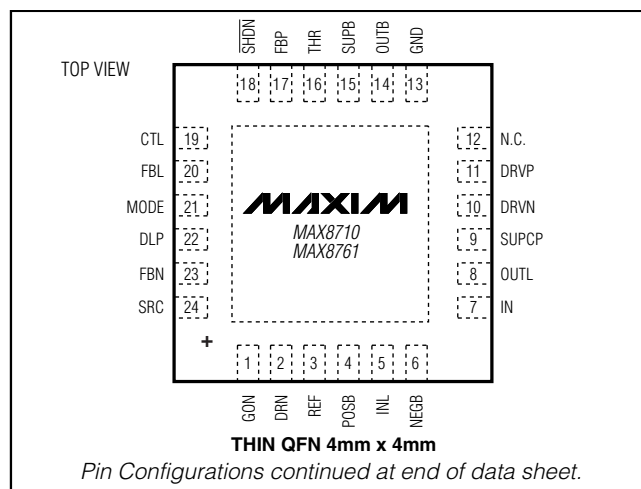

Dual Mode is a trademark of Maxim Integrated Products, Inc.

## Features

- ◆ High-Performance Linear Regulator
  - 1.6% Output Accuracy
  - Works with Small Ceramic Output Capacitors
  - Fast Transient Response
  - Foldback Current Limit
- ◆ 50mA Negative Regulated Charge Pump
- ◆ 20mA Positive Regulated Charge Pump with Adjustable Delay
- ◆ Built-In Power-Up Sequence
- ◆ High-Current Operational Amplifier (MAX8710/MAX8711/MAX8761)
  - ±150mA Output Short-Circuit Current
  - 12V/μs Slew Rate
  - 12MHz, -3dB Bandwidth
  - Rail-to-Rail Inputs/Output
- ◆ Dual-Mode™ High-Voltage Switches (MAX8710/MAX8761)
- ◆ Thermal Protection
- ◆ Latched Fault Protection with Timer

## Ordering Information

PART	TEMP RANGE	PIN-PACKAGE	PKG CODE
MAX8710ETG+	-40°C to +100°C	24 Thin QFN 4mm x 4mm	T2444-4
MAX8711ETE+	-40°C to +100°C	16 Thin QFN 4mm x 4mm	T2444-4
MAX8712ETC+	-40°C to +100°C	12 Thin QFN 4mm x 4mm	T2444-4
MAX8761ETG+	-40°C to +85°C	24 Thin QFN 4mm x 4mm	T2444-4

+Denotes lead-free package.

## Minimum Operating Circuit

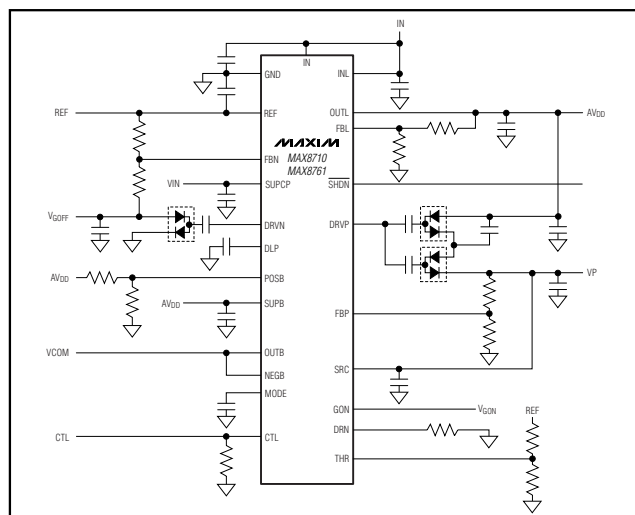

# Low-Cost, Linear-Regulator LCD Panel Power Supplies

## ABSOLUTE MAXIMUM RATINGS

CTL, FBL, FBP, FBN,  $\overline{\text{SHDN}}$ , REF, THR to GND.....-0.3V to +6V  
 MODE, DLP to GND.....-0.3V to  $V_{\text{REF}} + 0.3\text{V}$   
 IN, INL to GND.....-0.3V to +28V  
 SUPCP, SUPB to GND.....-0.3V to +14V  
 OUTL (MAX8710/MAX8761).....-0.3V to +28V  
 OUTL (MAX8711/MAX8712).....-0.3V to +14V  
 POSB, OUTB, NEGB to GND.....-0.3V to  $V_{\text{SUPB}} + 0.3\text{V}$   
 DRVN, DRVP (MAX8710/MAX8761).....-0.3V to ( $V_{\text{SUPCP}} - 0.3\text{V}$ )  
 DRVN, DRVP (MAX8711/MAX8712).....-0.3V to ( $V_{\text{IN}} - 0.3\text{V}$ )  
 SRC to GND.....-0.3V to +30V  
 GON, DRN to GND.....-0.3V to  $V_{\text{SRC}} + 0.3\text{V}$   
 DRN to GON.....-30V to +30V

OUTB Maximum Continuous Output Current.....±75mA  
 DRVP RMS Output Current.....90mA  
 DRVN RMS Output Current.....-150mA  
 Continuous Power Dissipation ( $T_A = +70^\circ\text{C}$ )  
 24-, 16-, and 12-Pin Thin QFN 4mm x 4mm  
 (derate 16.9mW/°C above +70°C).....1349mW  
 Operating Temperature Range  
 MAX8710/MAX8711/MAX8712.....-40°C to +100°C  
 MAX8761.....-40°C to +85°C  
 Junction Temperature.....+150°C  
 Storage Temperature Range.....-65°C to +160°C  
 Lead Temperature (soldering, 10s).....+300°C

Stresses beyond those listed under "Absolute Maximum Ratings" may cause permanent damage to the device. These are stress ratings only, and functional operation of the device at these or any other conditions beyond those indicated in the operational sections of the specifications is not implied. Exposure to absolute maximum rating conditions for extended periods may affect device reliability.

## ELECTRICAL CHARACTERISTICS

(Circuit of Figure 1.  $V_{\text{IN}} = V_{\text{INL}} = V_{\text{SUPCP}} = 12\text{V}$ ,  $V_{\text{OUTL}} = V_{\text{SUPB}} = 10\text{V}$ ,  $V_{\text{SRC}} = 27\text{V}$ ,  $T_A = 0^\circ\text{C}$  to  $+85^\circ\text{C}$ . Typical values are at  $T_A = +25^\circ\text{C}$ , unless otherwise noted.)

PARAMETER	CONDITIONS	MIN	TYP	MAX	UNITS
IN Operating Supply Range		8		28	V
IN Quiescent Current	$\overline{\text{SHDN}} = \text{GND}$		0.2	0.4	mA
	$\overline{\text{SHDN}} = 3.3\text{V}$			2.5	
Duration to Trigger Fault Condition	$2^{16}$ oscillator clock cycles		44		ms
REF Output Voltage	$-10\mu\text{A} < I_{\text{REF}} < 1\text{mA}$ (excluding internal load)	4.9	5.0	5.1	V
SUPCP Input Supply Range		2.7		13.2	V
Charge-Pump Regulators Operating Frequency		1275	1500	1725	kHz
Thermal Shutdown	Rising temperature, 15°C hysteresis		+160		°C
<b>LINEAR REGULATOR</b>					
INL Operation Supply Range	$V_{\text{OUTL}} < V_{\text{INL}}$	7		28	V
Dropout Voltage	$I_{\text{OUTL}} = 50\text{mA}$ (MAX8710/MAX8711/MAX8712)	150		300	mV
	$I_{\text{OUTL}} = 200\text{mA}$ (MAX8761)	200		400	
FBL Regulation Voltage	$I_{\text{OUTL}} = 50\text{mA}$	2.46	2.50	2.54	V
FBL Input Bias Current	$V_{\text{FBL}} = 2.5\text{V}$			50	nA
FBL Fault Trip Level	Falling edge	1.92	2.00	2.08	V
FBL Line-Regulation Error	$V_{\text{INL}} = V_{\text{IN}} = 10.8\text{V} \sim 13.2\text{V}$ , $V_{\text{OUTL}} = 10\text{V}$ , $I_{\text{OUTL}} = 50\text{mA}$			15	mV
	$V_{\text{INL}} = V_{\text{IN}} = 10\text{V} \sim 28\text{V}$ , $V_{\text{OUTL}} = 9\text{V}$ , $I_{\text{OUTL}} = 50\text{mA}$		10		
Bandwidth	Guaranteed by design	1000			kHz
Maximum OUTL Current	$V_{\text{FBL}} = 2.4\text{V}$ (MAX8710/MAX8711/MAX8712)	300			mA
	$V_{\text{FBL}} = 2.4\text{V}$ (MAX8761)	500			
OUTL Soft-Start Period	$2^{12}$ oscillator clock cycles in a 7-bit DAC		2.73		ms
OUTL Load Regulation	$V_{\text{IN}} = 12\text{V}$ , $5\text{mA} < I_{\text{OUT}} < 300\text{mA}$ (MAX8710/MAX8711/MAX8712)			2	%
	$V_{\text{IN}} = 12\text{V}$ , $5\text{mA} < I_{\text{OUT}} < 500\text{mA}$ (MAX8761)			2	

# Low-Cost, Linear-Regulator LCD Panel Power Supplies

## ELECTRICAL CHARACTERISTICS (continued)

(Circuit of Figure 1.  $V_{IN} = V_{INL} = V_{SUPCP} = 12V$ ,  $V_{OUTL} = V_{SUPB} = 10V$ ,  $V_{SRC} = 27V$ ,  $T_A = 0^{\circ}C$  to  $+85^{\circ}C$ . Typical values are at  $T_A = +25^{\circ}C$ , unless otherwise noted.)

PARAMETER	CONDITIONS	MIN	TYP	MAX	UNITS
<b>OPERATIONAL AMPLIFIER (MAX8710/MAX8711/MAX8761)</b>					
SUPB Supply Operating Range		4.5		13.2	V
SUPB Supply Current	Buffer configuration, $V_{POSB} = 4V$ , no load		0.7	1.0	mA
Input Offset Voltage	$(V_{NEGB}, V_{POSB}) = V_{SUPB} / 2$ , $T_A = +25^{\circ}C$		0	12	mV
Input Bias Current	$(V_{NEGB}, V_{POSB}) = V_{SUPB} / 2$	-50	+1	+50	nA
Common-Mode Input Range	$V_{NEGB}, V_{POSB}$	0		$V_{SUPB}$	V
Common-Mode Rejection Ratio	$0 \leq (V_{NEGB}, V_{POSB}) < V_{SUPB}$	50	90		dB
Open-Loop Gain			125		dB
Output Voltage Swing High	$I_{OUTB} = 100\mu A$	$V_{SUPB} - 15$	$V_{SUPB} - 2$		mV
	$I_{OUTB} = 5mA$	$V_{SUPB} - 150$	$V_{SUPB} - 80$		
Output Voltage Swing Low	$I_{OUTB} = -100\mu A$		2	15	mV
	$I_{OUTB} = -5mA$		80	150	
Short-Circuit Current	Short to $V_{SUPB} / 2$ , sourcing	50	150		mA
	Short to $V_{SUPB} / 2$ , sinking	50	140		
Output Current	Buffer configuration, $V_{POSB} = 4V$ , $V_{OUTB}$ error $< \pm 10mV$		$\pm 40$		mA
Power-Supply Rejection Ratio	$6V \leq V_{SUPB} \leq 13.2V$ , DC $(V_{NEGB}, V_{POSB}) = V_{SUPB} / 2$	60	100		dB
Slew Rate			12		V/ $\mu s$
-3dB Bandwidth	Buffer configuration, $R_L = 10k\Omega$ , $C_L = 10pF$		12		MHz
Gain-Bandwidth Product	Buffer configuration, $R_L = 10k\Omega$ , $C_L = 10pF$		8		MHz
<b>POSITIVE CHARGE-PUMP REGULATOR</b>					
FBP Regulation Voltage	$I_{GON} = 10mA$	2.425	2.500	2.575	V
FBP Line-Regulation Error	$V_{OUTL}$ ( $V_{SUPCP}$ , MAX8710/MAX8761) = 10.8V~13.2V, $V_{GON} = 27V$ , $I_{GON} = 20mA$			25	mV
FBP Input Bias Current	$V_{FBP} = 2.5V$	-50		+50	nA
DRVp p-Channel On-Resistance			15	30	$\Omega$
DRVp n-Channel On-Resistance	$V_{FBP} = 2.4V$		6	12	$\Omega$
	$V_{FBP} = 2.6V$	20			k $\Omega$
FBP Fault Trip Level	Falling edge	1.92	2.00	2.08	V
Positive Charge-Pump Soft-Start Period	$2^{12}$ oscillator clock cycles in a 7-bit DAC		2.73		ms
<b>NEGATIVE CHARGE-PUMP REGULATOR</b>					
FBN Regulation Voltage	$I_{GOFF} = 10mA$	200	250	300	mV
FBN Input Bias Current	$V_{FBN} = 250mV$	-50		+50	nA
FBN Line Regulation	$V_{OUTL}$ ( $V_{SUPCP}$ , MAX8710/MAX8761) = 10.8V~13.2V, $V_{VGOFF} = -6V$ , $I_{GOFF} = -50mA$			25	mV
DRVn p-Channel On-Resistance			7.5	15	$\Omega$

MAX8710/MAX8711/MAX8712/MAX8761

# Low-Cost, Linear-Regulator LCD Panel Power Supplies

## ELECTRICAL CHARACTERISTICS (continued)

(Circuit of Figure 1.  $V_{IN} = V_{INL} = V_{SUPCP} = 12V$ ,  $V_{OUTL} = V_{SUPB} = 10V$ ,  $V_{SRC} = 27V$ ,  $T_A = 0^{\circ}C$  to  $+85^{\circ}C$ . Typical values are at  $T_A = +25^{\circ}C$ , unless otherwise noted.)

PARAMETER	CONDITIONS	MIN	TYP	MAX	UNITS
DRVN n-Channel On-Resistance	$V_{FBN} = 350mV$		3	6	$\Omega$
	$V_{FBN} = 150mV$	20			$k\Omega$
FBN Fault Trip Level	Rising edge		700		mV
Negative Charge-Pump Soft-Start Period	$2^{12}$ oscillator clock cycles in a 7-bit DAC		2.73		ms
<b>SEQUENCE CONTROL</b>					
SHDN Input Low Voltage				0.6	V
SHDN Input High Voltage		2.0			V
SHDN Input Current				1	$\mu A$
DLP Capacitor Charge Current	During startup, $V_{DLP} = 1.0V$	4	5	6	$\mu A$
DLP Turn-On Threshold		2.375	2.5	2.625	V
Pin Discharge Switch On-Resistance	SHDN = low or fault tripped; DLP, FBP, FBN to GND		10		$\Omega$
	SHDN = low or fault tripped; MODE, OUTL, OUTB to GND MAX8710, SHDN = low or fault trip; GON to GND		1		$k\Omega$
<b>POSITIVE GATE-DRIVER TIMING AND CONTROL SWITCHES (MAX8710/MAX8761)</b>					
CTL Input Low Voltage				0.6	V
CTL Input High Voltage		2.0			V
CTL Input Leakage Current		-1		+1	$\mu A$
CTL to GON Rising Propagation Delay	$V_{MODE} = V_{REF}$ , 1.5nF from GON to GND, $V_{CTL} = 0$ to 3V step, no load on GON, measured from $V_{CTL} = 1.5V$ to GON = 20%		100		ns
CTL to GON Falling Propagation Delay	$V_{MODE} = V_{REF}$ , 1.5nF from GON to GND, $V_{CTL} = 3V$ to 0 step, DRN falling, no load on DRN and GON, measured from $V_{CTL} = 1.5V$ to GON = 80%		100		ns
SRC Input Voltage Range				28	V
SRC Input Current	$V_{MODE} = V_{REF}$ , $V_{DLP} = 3V$ , CTL = high		150	250	$\mu A$
DRN Input Current	$V_{MODE} = V_{REF}$ , $V_{DRN} = 8V$ , $V_{DLP} = 3V$ , $V_{CTL} = 0V$		26	40	$\mu A$
SRC Switch On-Resistance	$V_{MODE} = V_{REF}$ , $V_{DLP} = 3V$ , CTL = high		20	40	$\Omega$
DRN Switch On-Resistance	$V_{MODE} = V_{REF}$ , $V_{DLP} = 3V$ , $V_{CTL} = 0V$		60		$\Omega$
MODE Switch On-Resistance			1		$k\Omega$
Mode 2 MODE Capacitor Charge Current	$V_{MODE} <$ MODE current-source stop voltage threshold	42	50	64	$\mu A$
MODE Voltage Threshold for Enabling DRN Switch Control in Mode 2		2.3	2.5	2.7	V
MODE Current-Source Stop Voltage Threshold	$V_{MODE}$ rising, $C_{MODE} = 150pF$	3.3	3.5	3.7	V
THR to GON Voltage Gain		9.4	10	10.6	V/V
GON Falling Slew Rate			13.5		V/ $\mu s$

# Low-Cost, Linear-Regulator LCD Panel Power Supplies

MAX8710/MAX8711/MAX8712/MAX8761

## ELECTRICAL CHARACTERISTICS

(Circuit of Figure 1.  $V_{IN} = V_{INL} = V_{SUPCP} = 12V$ ,  $V_{OUTL} = V_{SUPB} = 10V$ ,  $V_{SRC} = 27V$ ,  $T_A = -40^{\circ}C$  to  $+100^{\circ}C$  ( $-40^{\circ}C$  to  $85^{\circ}C$  for MAX8761), unless otherwise noted.) (Note 1)

PARAMETER	CONDITIONS	MIN	TYP	MAX	UNITS
REF Output Voltage	$-10\mu A < I_{REF} < 1mA$ (excluding internal load)	4.9		5.1	V
SUPCP Input Supply Range		2.7		13.2	V
Charge-Pump Regulators Operating Frequency		1200		1850	kHz
<b>LINEAR REGULATOR</b>					
Dropout Voltage	$I_{OUTL} = 50mA$ (MAX8710/MAX8711/MAX8712)			300	mV
	$I_{OUTL} = 200mA$ (MAX8761)			400	
FBL Regulation Voltage	$I_{OUTL} = 50mA$	2.455		2.545	V
FBL Fault Trip Level	Falling edge	1.96		2.04	V
FBL Line-Regulation Error	$V_{INL} = V_{IN} = 10.8V \sim 13.2V$ , $V_{OUTL} = 10V$ , $I_{OUTL} = 50mA$			15	mV
Maximum OUTL Current	$V_{FBL} = 2.4V$ (MAX8710/MAX8711/MAX8712)	300			mA
	$V_{FBL} = 2.4V$ (MAX8761)	500			
OUTL Load Regulation	$V_{IN} = 12V$ , $5mA < I_{OUT} < 300mA$ (MAX8710/MAX8711/MAX8712)			2	%
	$V_{IN} = 12V$ , $5mA < I_{OUT} < 500mA$ (MAX8761)			2	
<b>OPERATIONAL AMPLIFIER (MAX8710/MAX8711/MAX8761)</b>					
SUPB Supply Current	Buffer configuration, $V_{POSB} = 4V$ , no load			1.0	mA
Input Offset Voltage	$(V_{NEGB}, V_{POSB}) = V_{SUPB} / 2$			14	mV
Output-Voltage-Swing High	$I_{OUTB} = 100\mu A$	$V_{SUPB} - 15$			mV
	$I_{OUTB} = 5mA$	$V_{SUPB} - 150$			
Output-Voltage-Swing Low	$I_{OUTB} = -100\mu A$			15	mV
	$I_{OUTB} = -5mA$			150	
Short-Circuit Current	Short to $V_{SUPB} / 2$ , sourcing	50			mA
	Short to $V_{SUPB} / 2$ , sinking	50			
<b>POSITIVE CHARGE-PUMP REGULATOR</b>					
FBP Regulation Voltage	$I_{GON} = 10mA$	MAX8710/MAX8711/MAX8712	2.425	2.575	V
		MAX8761	2.40	2.65	
FBP Line-Regulation Error	$V_{OUTL} (V_{SUPCP}, MAX8710)$ $= 10.8V \sim 13.2V$ , $V_{GON} = 27V$ , $I_{GON} = 20mA$			25	mV
	$V_{OUTL} (V_{SUPCP}, MAX8761)$ $= 10.8V \sim 13.2V$ , $V_{GON} = 27V$ , $I_{GON} = 20mA$			50	
DRVP p-Channel On-Resistance				30	$\Omega$
DRVP n-Channel On-Resistance	$V_{FBP} = 2.4V$			12	$\Omega$
	$V_{FBP} = 2.6V$	20			k $\Omega$
<b>NEGATIVE CHARGE-PUMP REGULATOR</b>					
FBN Regulation Voltage	$I_{GOFF} = 10mA$	200		300	mV
FBN Line Regulation	$V_{OUTL} (V_{SUPCP}, MAX8710/MAX8761)$ $= 10.8V \sim 13.2V$ , $V_{GOFF} = -6V$ , $I_{GOFF} = -50mA$			25	mV
DRVN p-Channel On-Resistance				15	$\Omega$

# Low-Cost, Linear-Regulator LCD Panel Power Supplies

## ELECTRICAL CHARACTERISTICS (continued)

(Circuit of Figure 1.  $V_{IN} = V_{INL} = V_{SUPCP} = 12V$ ,  $V_{OUTL} = V_{SUPB} = 10V$ ,  $V_{SRC} = 27V$ ,  $T_A = -40^{\circ}C$  to  $+100^{\circ}C$ , ( $-40^{\circ}C$  to  $+85^{\circ}C$  for MAX8761), unless otherwise noted.) (Note 1)

PARAMETER	CONDITIONS	MIN	TYP	MAX	UNITS
DRVN n-Channel On-Resistance	$V_{FBN} = 350mV$			6	$\Omega$
	$V_{FBN} = 150mV$	20			$k\Omega$
<b>SEQUENCE CONTROL</b>					
$\overline{SHDN}$ Input Low Voltage				0.6	V
$\overline{SHDN}$ Input High Voltage	MAX8710/MAX8711/MAX8712	2.0			V
	MAX8761	2.05			
DLP Capacitor Charge Current	During startup, $V_{DLP} = 1.0V$	4		6	$\mu A$
DLP Turn-On Threshold		2.375		2.625	V
<b>POSITIVE GATE-DRIVER TIMING AND CONTROL SWITCHES (MAX8710/MAX8761)</b>					
SRC Input Current	$V_{MODE} = V_{REF}$ , $V_{DLP} = 3V$ , $CTL = high$			250	$\mu A$
DRN Input Current	$V_{MODE} = V_{REF}$ , $V_{DRN} = 8V$ , $V_{DLP} = 3V$ , $V_{CTL} = 0V$			40	$\mu A$
SRC Switch On-Resistance	$V_{MODE} = V_{REF}$ , $V_{DLP} = 3V$ , $CTL = high$			40	$\Omega$
Mode 2 MODE Capacitor Charge Current	$V_{MODE} < MODE$ current-source stop voltage threshold	42		64	$\mu A$
MODE Voltage Threshold for Enabling DRN Switch Control in Mode 2		2.3		2.7	V

**Note 1:** Specifications to  $-40^{\circ}C$  and  $+85^{\circ}C$  are guaranteed by design, not production tested.

## Typical Operating Characteristics

(Circuit of Figure 1.  $V_{IN} = V_{INL} = V_{SUPCP} = 12V$ ,  $V_{OUTL} = V_{SUPB} = 10V$ ,  $V_{SRC} = 27V$ ,  $T_A = 0^{\circ}C$  to  $+85^{\circ}C$ . Typical values are at  $T_A = +25^{\circ}C$ , unless otherwise noted.)

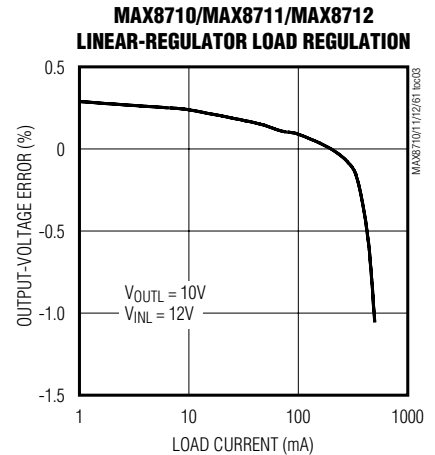
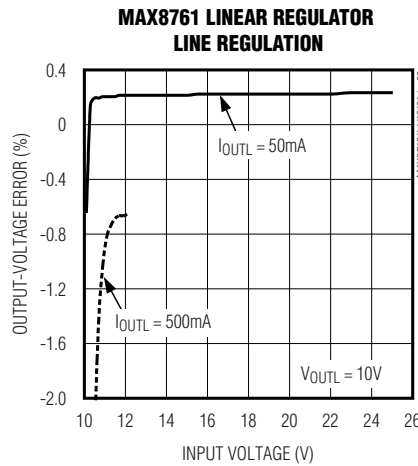
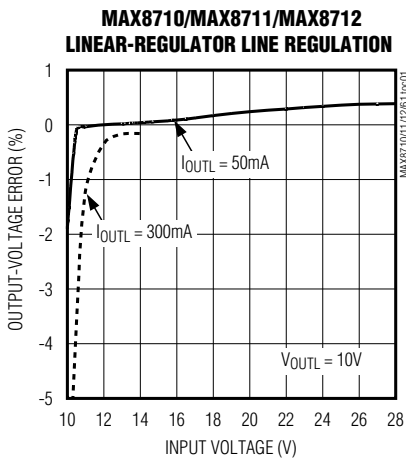

# Low-Cost, Linear-Regulator LCD Panel Power Supplies

## Typical Operating Characteristics (continued)

(Circuit of Figure 1.  $V_{IN} = V_{INL} = V_{SUPCP} = 12V$ ,  $V_{OUTL} = V_{SUPB} = 10V$ ,  $V_{SRC} = 27V$ ,  $T_A = 0^\circ C$  to  $+85^\circ C$ . Typical values are at  $T_A = +25^\circ C$ , unless otherwise noted.)

MAX8710/MAX8711/MAX8712/MAX8761

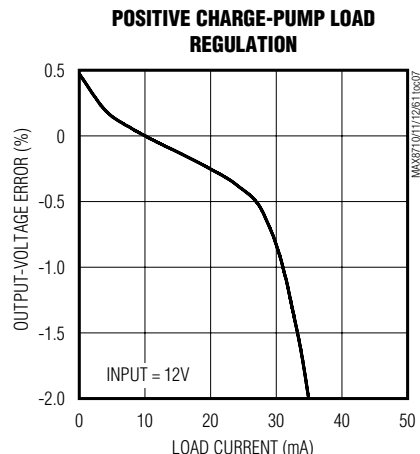
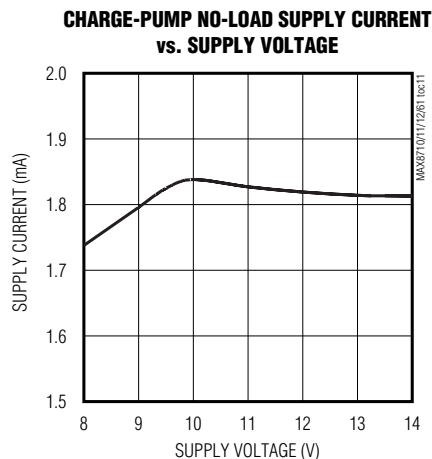
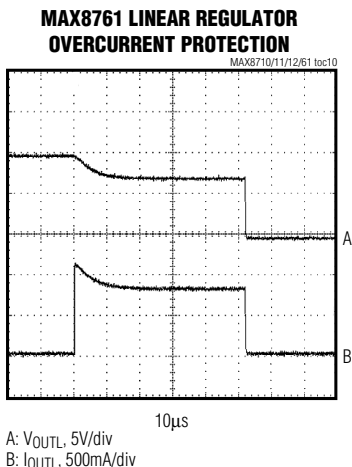
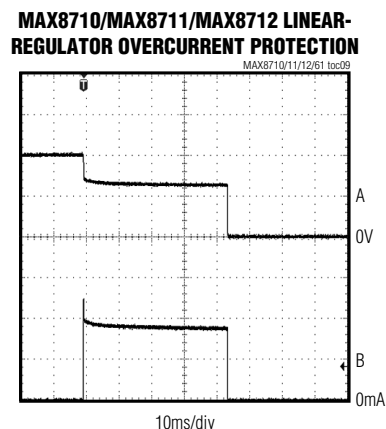
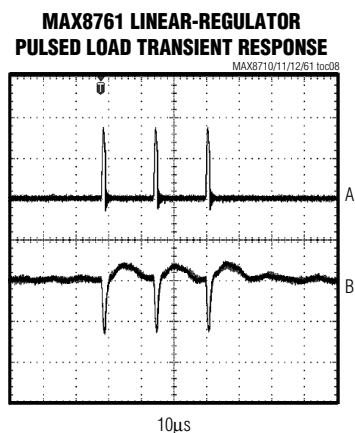
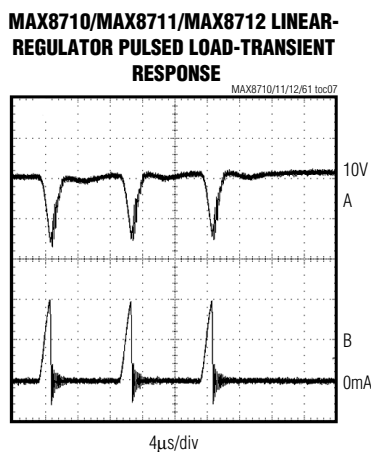
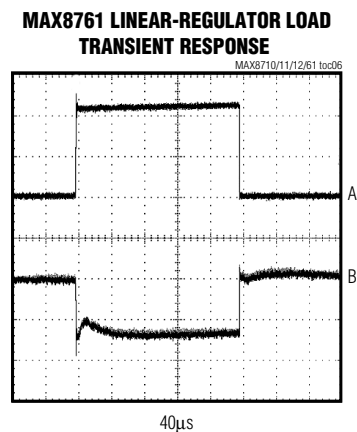
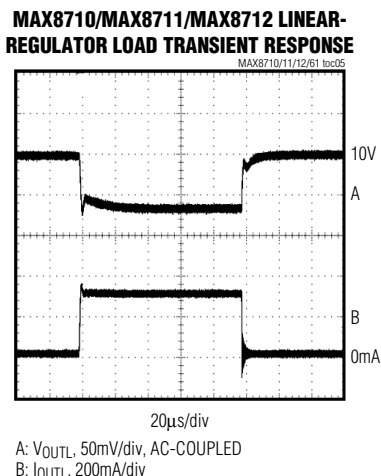
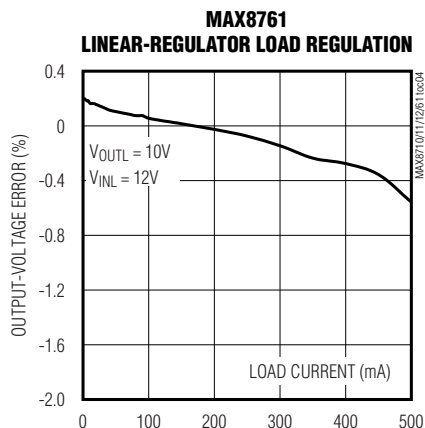

# Low-Cost, Linear-Regulator LCD Panel Power Supplies

## Typical Operating Characteristics (continued)

(Circuit of Figure 1.  $V_{IN} = V_{INL} = V_{SUPCP} = 12V$ ,  $V_{OUTL} = V_{SUPB} = 10V$ ,  $V_{SRC} = 27V$ ,  $T_A = 0^\circ C$  to  $+85^\circ C$ . Typical values are at  $T_A = +25^\circ C$ , unless otherwise noted.)

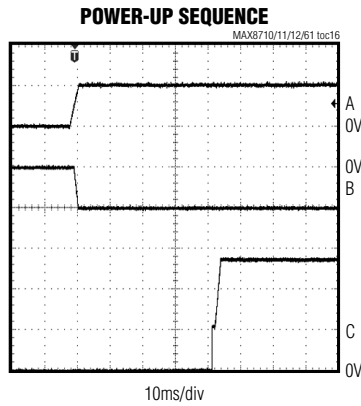
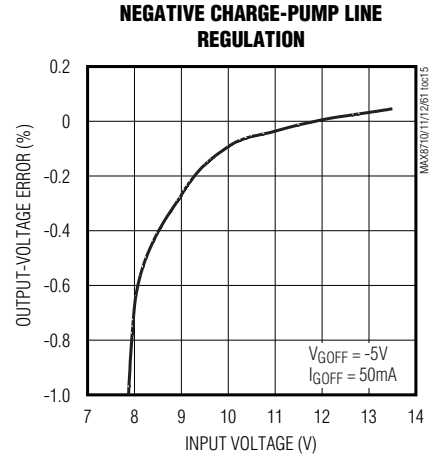
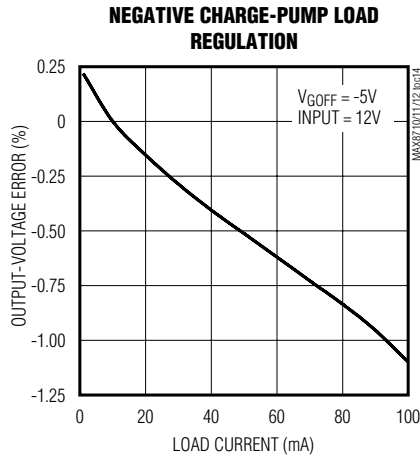
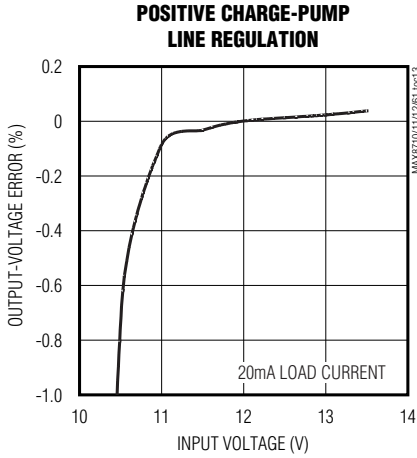

A:  $V_{OUTL}$ , 10V/div  
B:  $V_{GOFF}$ , 5V/div  
C:  $V_{GON}$ , 10V/div

**MAX8710/MAX8761 SWITCH CONTROL FUNCTION (MODE 1)**

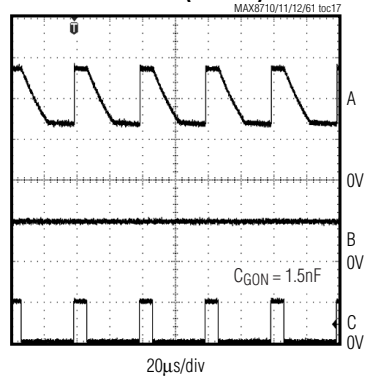

A:  $V_{GON}$ , 10V/div  
B:  $V_{MODE}$ , 5V/div  
C:  $V_{CTL}$ , 5V/div

**MAX8710/MAX8761 SWITCH CONTROL FUNCTION (MODE 2)**

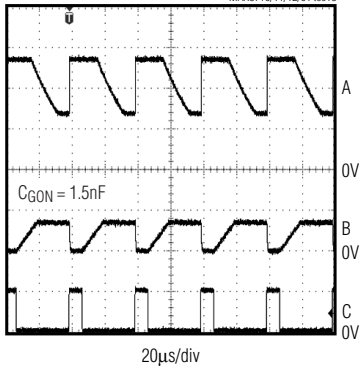

A:  $V_{GON}$ , 10V/div  
B:  $V_{MODE}$ , 5V/div  
C:  $V_{CTL}$ , 5V/div

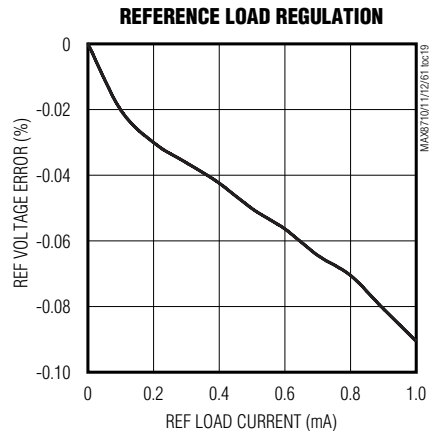

# Low-Cost, Linear-Regulator LCD Panel Power Supplies

## Typical Operating Characteristics (continued)

(Circuit of Figure 1.  $V_{IN} = V_{INL} = V_{SUPCP} = 12V$ ,  $V_{OUTL} = V_{SUPB} = 10V$ ,  $V_{SRC} = 27V$ ,  $T_A = 0^\circ C$  to  $+85^\circ C$ . Typical values are at  $T_A = +25^\circ C$ , unless otherwise noted.)

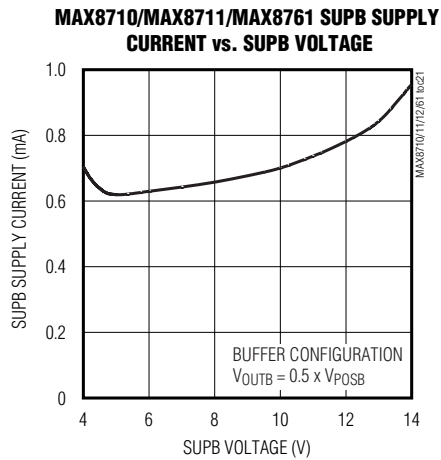
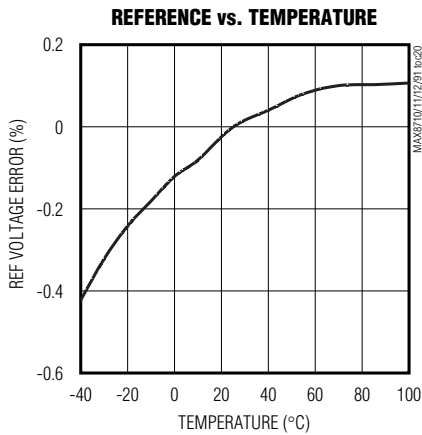

**MAX8710/MAX8711/MAX8761 OPERATIONAL-AMPLIFIER SMALL-SIGNAL STEP RESPONSE (BUFFER CONFIGURATION)**

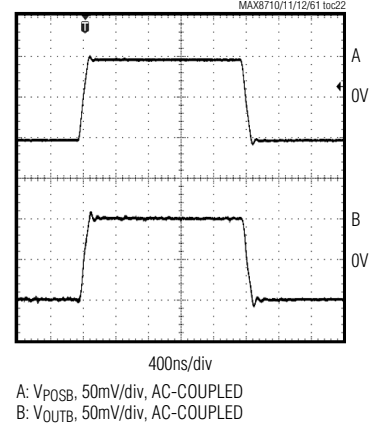

**MAX8710/MAX8711/MAX8761 OPERATIONAL-AMPLIFIER LARGE-SIGNAL STEP RESPONSE (BUFFER CONFIGURATION)**

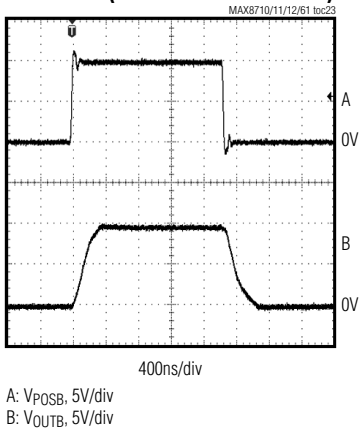

**MAX8710/MAX8711/MAX8761 OPERATIONAL-AMPLIFIER LOAD TRANSIENT RESPONSE (BUFFER CONFIGURATION)**

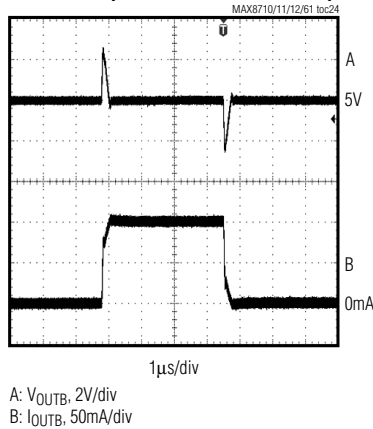

**MAX8710/MAX8711/MAX8761 OPERATIONAL-AMPLIFIER RAIL-TO-RAIL I/O**

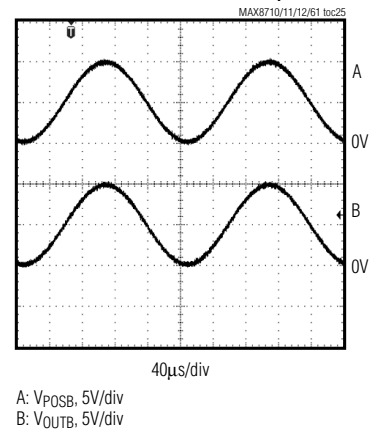

MAX8710/MAX8711/MAX8712/MAX8761

# Low-Cost, Linear-Regulator LCD Panel Power Supplies

## Pin Description

PIN			NAME	FUNCTION
MAX8710/ MAX8761	MAX8711	MAX8712		
1	—	—	GON	Internal High-Voltage MOSFET Switch Common Terminal. GON is the output of the high-voltage switch-control block. GON is internally pulled to GND by a 1k $\Omega$ resistor in shutdown for the MAX8710. GON is not pulled to GND for the MAX8761.
2	—	—	DRN	Switch Input. Drain of the internal high-voltage back-to-back p-channel MOSFETs connected to GON.
3	1	1	REF	Reference Output. Connect a 0.22 $\mu$ F capacitor from REF to GND. REF remains on in shutdown.
4	2	—	POSB	Operational-Amplifier Noninverting Input
5	3	2	INL	Linear-Regulator Supply Input
6	4	—	NEGB	Operational-Amplifier Inverting Input
7	5	3	IN	IC Supply Input. Bypass IN to GND with a 0.1 $\mu$ F capacitor.
8	6	4	OUTL	Linear-Regulator Output. OUTL is internally pulled to GND by a 1k $\Omega$ resistor in shutdown. For the MAX8711/MAX8712, OUTL is also the supply input for the charge-pump regulators.
9	—	—	SUPCP	Supply Input for the Charge-Pump Regulators. Connect a 0.1 $\mu$ F capacitor from SUPCP to GND.
10	7	5	DRVN	Negative Charge-Pump Driver Output. Output high level is V <sub>SUPCP</sub> , and output low level is GND. DRVN is internally pulled high to SUPCP when the negative charge pump is disabled.
11	8	6	DRVP	Positive Charge-Pump Driver Output. Output high level is V <sub>SUPCP</sub> , and output low level is GND. DRVP is internally pulled low in shutdown.
12	—	—	N.C.	No Connection. Not internally connected.
13	9	7	GND	Ground
14	10	—	OUTB	Operational-Amplifier Output. OUTB is internally pulled to GND by a 1k $\Omega$ resistor in shutdown.
15	11	—	SUPB	Operational-Amplifier Supply Input. Bypass SUPB to GND with a 0.1 $\mu$ F capacitor.
16	—	—	THR	GON Low-Level Regulation Set-Point Input. Connect THR to the center of a resistive voltage-divider between REF and GND to set the V <sub>GON</sub> regulation level. The actual level is 10 $\times$ V <sub>THR</sub> . See the <i>Switch Control (MAX8710/MAX8761)</i> section for details.
17	12	8	FBP	Positive Charge-Pump Feedback Input. Connect FBP to the center of a resistive voltage-divider between the positive charge-pump regulator output and GND to set the regulator output voltage. Place the divider within 5mm of FBP. FBP is internally pulled to GND by a 10 $\Omega$ resistor in shutdown.

# Low-Cost, Linear-Regulator LCD Panel Power Supplies

## Pin Description (continued)

PIN			NAME	FUNCTION
MAX8710/ MAX8761	MAX8711	MAX8712		
18	13	9	$\overline{\text{SHDN}}$	Active-Low Shutdown Control Input. Pull $\overline{\text{SHDN}}$ low to turn off all sections of the device except REF. Pull $\overline{\text{SHDN}}$ high to enable the device. Cycle $\overline{\text{SHDN}}$ to reset the device after a fault.
19	—	—	CTL	High-Voltage Switch-Control Block Timing Control Input. See the <i>Switch Control (MAX8710/MAX8761)</i> section for details.
20	14	10	FBL	Linear-Regulator Feedback Input. Connect FBL to the center of a resistive voltage-divider between the linear-regulator output and GND to set the linear-regulator output voltage. Place the divider within 5mm of FBL.
21	—	—	MODE	High-Voltage Switch-Control Block-Mode Selection Input and Timing-Adjustment Input. See the <i>Switch Control (MAX8710/MAX8761)</i> section for details. MODE is high impedance when it is connected to REF. MODE is internally pulled to GND by a 1k $\Omega$ resistor during REF UVLO, when $V_{\text{DLP}} < 2.5\text{V}$ , or in shutdown.
22	15	11	DLP	Positive Charge-Pump Startup Delay and High-Voltage Switch Delay Input. Connect a capacitor from DLP to GND to set the delay time. A 5 $\mu\text{A}$ current source charges $C_{\text{DLP}}$ . DLP is internally pulled to GND by a 10 $\Omega$ resistor in shutdown.
23	16	12	FBN	Negative Charge-Pump Feedback Input. Connect FBN to the center of a resistive voltage-divider between the negative output and REF to set the output voltage. Place the divider within 5mm of FBN. FBN is internally pulled to GND through a 10 $\Omega$ resistor in shutdown.
24	—	—	SRC	Switch Input. Source of the internal high-voltage p-channel MOSFET connected to GON.

### Typical Operating Circuit

Figures 1, 2, and 3 are the *Typical Operating Circuits* of the MAX8710/MAX8761, MAX8711, and MAX8712 for generating power rails in TFT LCD panels. The input voltage range is from 10.8V to 13.2V. The  $V_{\text{DD}}$  output is 10V at 300mA, the  $V_{\text{GON}}$  output is 27V at 20mA, and the  $V_{\text{GOFF}}$  output is -5V at 50mA.

### Detailed Description

The MAX8710/MAX8711/MAX8712/MAX8761 include a high-performance linear regulator, a positive charge-pump regulator, a negative charge-pump regulator, and built-in power-up sequence control. The MAX8710/MAX8711/MAX8761 also include a high-current operational amplifier. Additionally, the MAX8710/MAX8761 provide logic-controlled high-voltage switches to control the positive charge-pump output. The linear regulator directly steps down the input voltage to generate the source-driven

ICs' supply voltage. The two built-in charge-pump regulators are used to generate the TFT gate-on and gate-off supplies. The high-current operational amplifier is typically used to drive the LCD backplane (VCOM) and features high output current (150mA), fast slew rate (12V/ $\mu\text{s}$ ), and wide bandwidth (12MHz). Its rail-to-rail inputs and output maximize flexibility.

### Linear Regulator

The MAX8710/MAX8711/MAX8712/MAX8761 contain a linear regulator including a PMOS pass transistor. The MAX8710/MAX8711/MAX8712 can supply an output current of at least 300mA and the MAX8761 can supply at least 500mA. Connect an external resistive voltage-divider between the regulator output and GND with the midpoint connected to FBL to adjust the linear-regulator output. An error amplifier compares the FBL voltage with the 2.5V internal reference voltage and amplifies the difference. If the feedback voltage is higher than the



# Low-Cost, Linear-Regulator LCD Panel Power Supplies

MAX8710/MAX8711/MAX8712/MAX8761

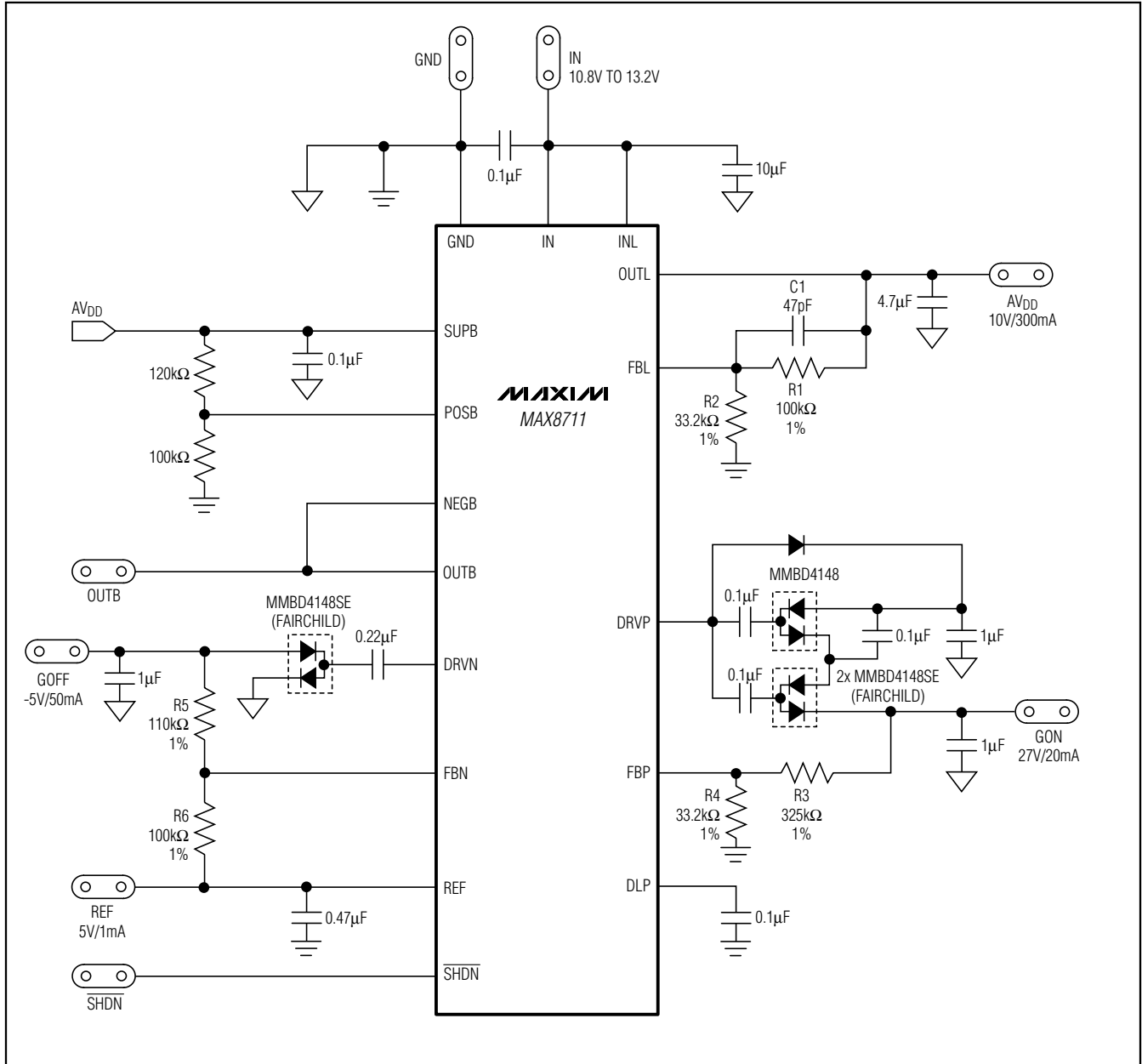

Figure 2. MAX8711 Typical Operating Circuit

# Low-Cost, Linear-Regulator LCD Panel Power Supplies

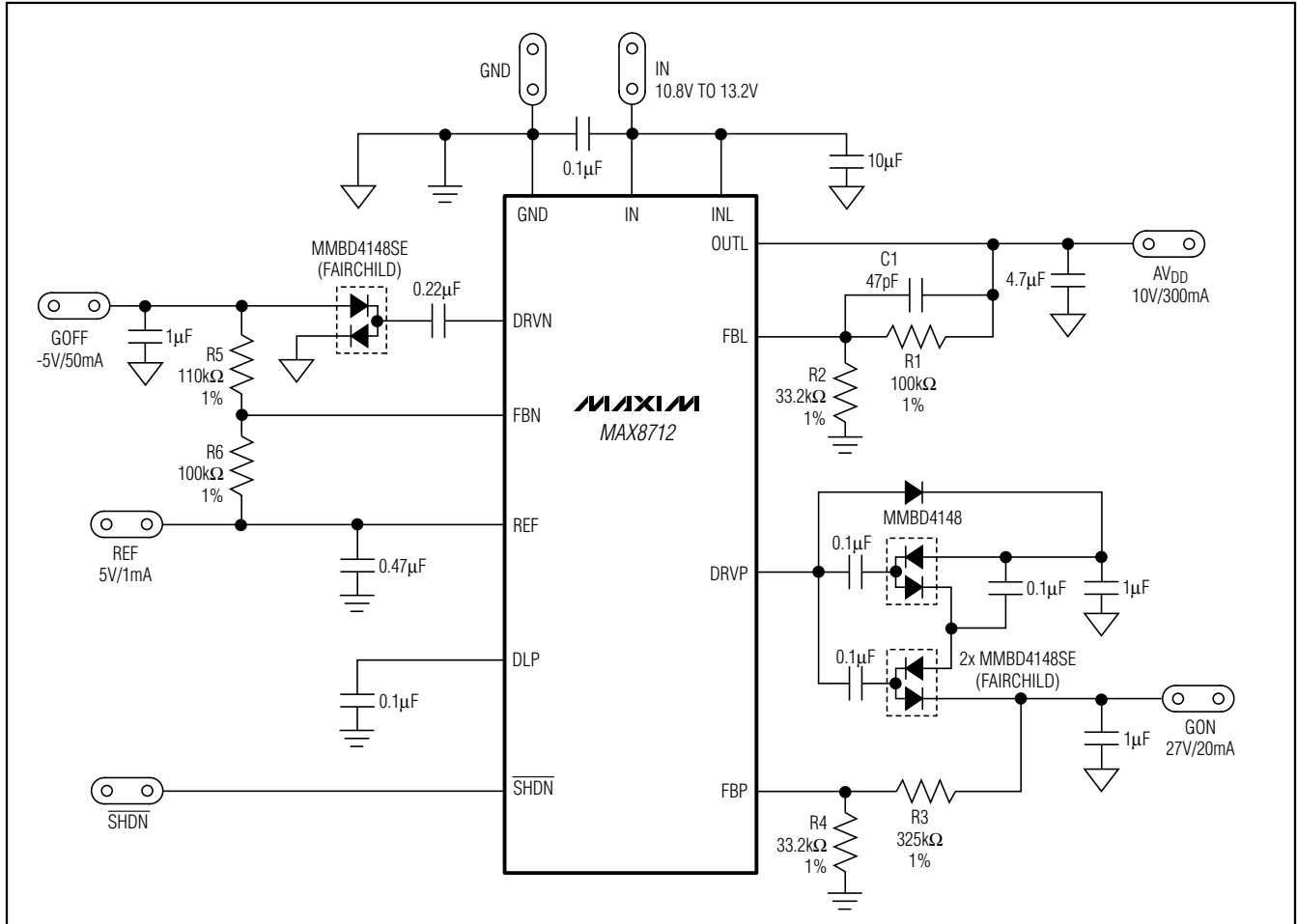

Figure 3. MAX8712 Typical Operating Circuit

reference voltage, the controller lowers the base current of the pnp transistor, which reduces the amount of current delivered to the output. If the feedback voltage is too low, the device increases the pnp transistor's base current, which allows more current to pass to the output and raises the output voltage. The linear regulator also includes an output current limit that protects the internal pass transistor against short circuits.

The input voltage range of the linear regulator is from 8V to 28V. The *Typical Operating Circuits* shown use a 12V input. The output voltage range of the linear regulator (OUTL) is up to 28V (MAX8710/MAX8761) or up to 13.2V (MAX8711/MAX8712). The linear-regulator output is used to generate the AV<sub>DD</sub> voltage, which is the analog supply rail for source-driver ICs in TFT LCD panels. The typical load of the AV<sub>DD</sub> supply is a periodic pulsed load, with a peak current of approximately 1A and pulse width of

approximately 2µs. The typical period of the pulse load is between 8.9µs and 31.7µs. The excellent transient performance of the linear regulator can easily meet this transient-response requirement.

The linear regulator can deliver at least 300mA (500mA for the MAX8761) output current continuously with a 4.7µF (10µF for the MAX8761) output capacitor. Do not allow the device power dissipation to exceed the package-dissipation limit listed in the *Absolute Maximum Ratings* section. The power dissipation can be estimated by multiplying the voltage difference between the input and the output with the required maximum continuous output current. For applications where the power dissipation exceeds the package limit, see the *External Transistor for Higher Current or Power Dissipation* section for more information.

# Low-Cost, Linear-Regulator LCD Panel Power Supplies

MAX8710/MAX8711/MAX8712/MAX8761

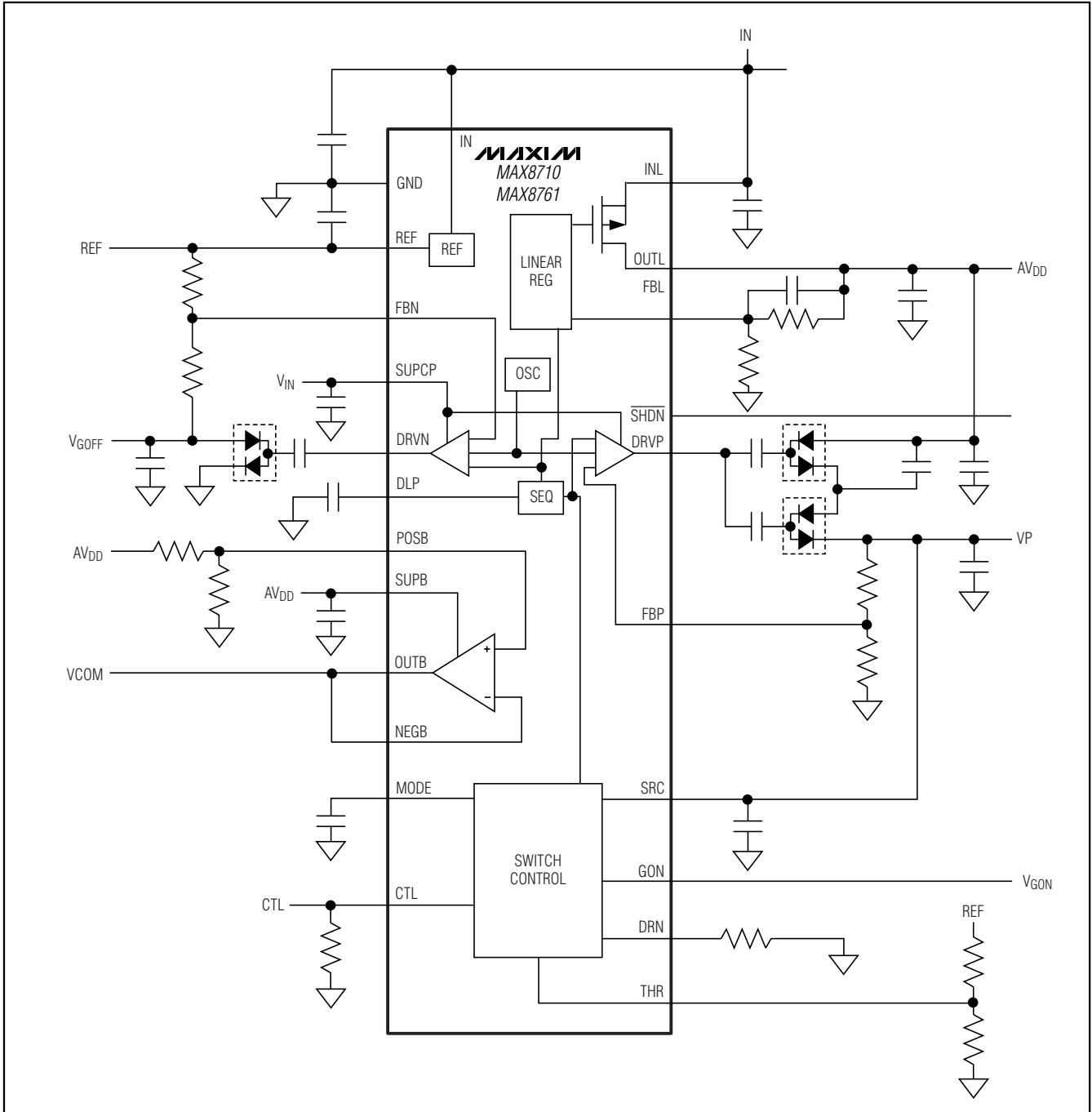

Figure 4. MAX8710/MAX8761 Functional Diagram

# Low-Cost, Linear-Regulator LCD Panel Power Supplies

The linear regulator is enabled whenever REF is in regulation and SHDN is logic high. Each time it is enabled, the linear regulator goes through a soft-start routine by ramping up its internal reference voltage from 0 to 2.5V in 128 steps. The soft-start period is 2.73ms (typ), and FBL fault detection is disabled during this period. This soft-start feature effectively limits the inrush current during startup.

The linear-regulator current-limit circuitry monitors the current flowing through the internal pass transistor. The internal current limit is approximately 800mA (1.1A for the MAX8761). The linear-regulator output declines when it is not able to supply the load current. If the FBL voltage drops below 0.75V, the current limit folds back to approximately 180mA (250mA for the MAX8761).

The MAX8710/MAX8711/MAX8712/MAX8761 monitor the FBL voltage for undervoltage conditions. If  $V_{FBL}$  is continuously below 2V (typ) for approximately 44ms, the device latches off. The foldback current-limit circuit, in conjunction with the output undervoltage fault latch and thermal-overload protection, protects the output load and the internal pass transistor against short circuits or overloads.

## Positive Charge-Pump Regulator

The positive charge-pump regulator is typically used to generate the positive supply rail for the TFT LCD gate-drivers

ICs. The output voltage is set with an external resistive voltage-divider from its output to GND with the midpoint connected to FBP. The number of charge-pump stages and the setting of the feedback divider determine the output voltage of the positive charge-pump regulator. The charge-pump driver includes a high-side p-channel MOSFET (P1) and a low-side n-channel MOSFET (N1) to control the power transfer as shown in Figure 5. The MOSFETs switch at a constant frequency of 1.5MHz.

During the first half-cycle, N1 turns on and allows  $V_{INPUT}$  ( $V_{SUPCP}$ , MAX8710/MAX8761 or  $V_{OUTL}$ , MAX8711/MAX8712) to charge up the flying capacitor  $C_X(POS)$  through diode D1. The amount of charge transferred from  $V_{INPUT}$  to  $C_X(POS)$  is determined by the on-resistance of N1, which varies according to the output of the feedback error amplifier. The error amplifier compares the feedback signal (FBP) with a 2.5V internal reference and amplifies the difference. If the feedback signal is below the reference, the error-amplifier output increases the supply voltage of N1's gate driver, lowering the on-resistance. Similarly, if the feedback signal is above the reference, the error-amplifier output reduces the driver supply voltage, increasing the on-resistance. During the second half-cycle, N1 turns off and P1 turns on, level shifting  $C_X(POS)$  by  $V_{INPUT}$  volts. This connects  $C_X(POS)$

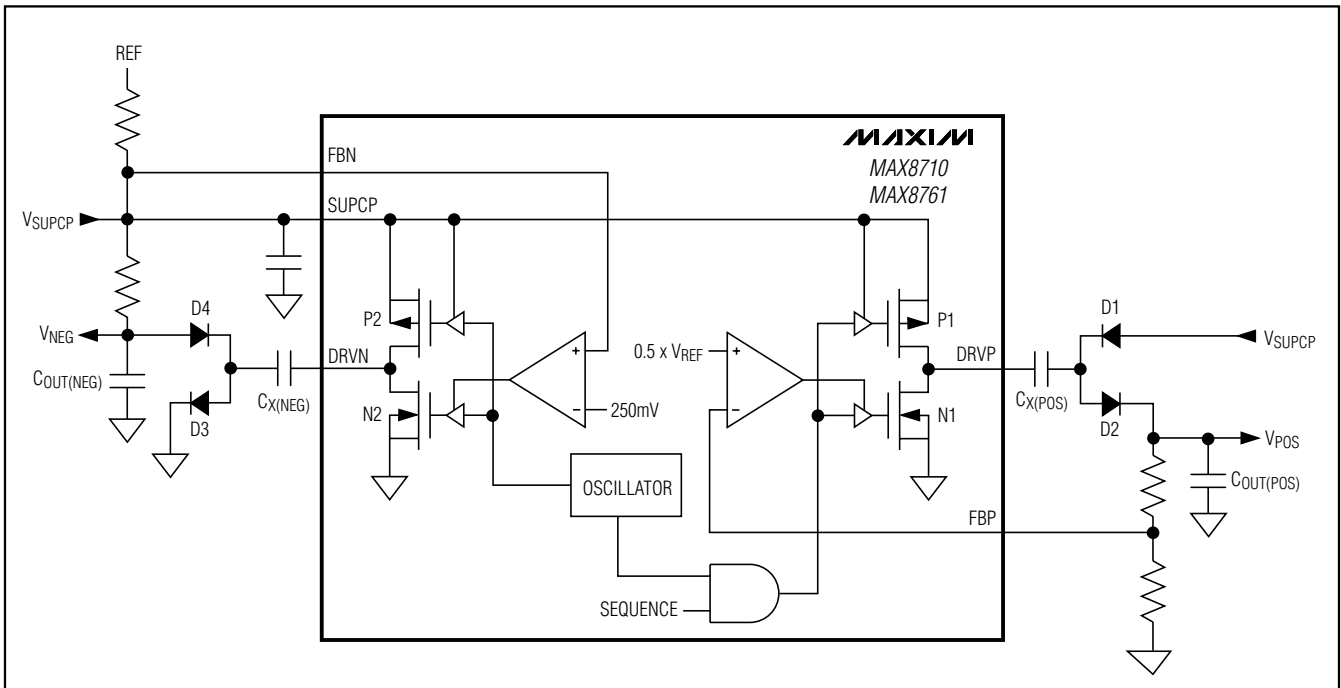

Figure 5. Charge-Pump Regulator Functional Diagram

# Low-Cost, Linear-Regulator LCD Panel Power Supplies

in parallel with the reservoir capacitor  $C_{OUT(POS)}$ . If the voltage across  $C_{OUT(POS)}$  plus a diode drop ( $V_{POS} + V_{DIODE}$ ) is smaller than the level-shifted flying-capacitor voltage ( $V_{CX(POS)} + V_{INPUT}$ ), charge flows from  $C_{X(POS)}$  to  $C_{OUT(POS)}$  until diode D2 turns off.

The positive charge-pump regulator's startup can be delayed by connecting an external capacitor from DLP to GND. An internal constant current source begins charging the DLP capacitor when  $\overline{SHDN}$  is logic high and REF reaches regulation. When the DLP voltage exceeds  $V_{REF} / 2$ , the positive charge-pump regulator is enabled. Each time it is enabled, the positive charge-pump regulator goes through a soft-start routine by ramping up its internal reference voltage from 0 to 2.5V in 128 steps. The soft-start period is 2.73ms (typ), and FBP fault detection is disabled during this period. The soft-start feature effectively limits the inrush current during startup. The MAX8710/MAX8711/MAX8712/MAX8761 also monitor the FBP voltage for undervoltage conditions. If  $V_{FBP}$  is continuously below 2V (typ) for approximately 44ms, the device latches off.

## Negative Charge-Pump Regulator

The negative charge-pump regulator is typically used to generate the negative supply rail for the TFT LCD gate-driver ICs. The output voltage is set with an external resistive voltage-divider from its output to REF with the midpoint connected to FBN. The number of charge-pump stages and the setting of the feedback divider determine the output of the negative charge-pump regulator. The charge-pump driver includes a high-side p-channel MOSFET (P2) and a low-side n-channel MOSFET (N2) to control the power transfer as shown in Figure 5. The MOSFETs switch a constant frequency of 1.5MHz.

During the first half-cycle, P2 turns on and allows  $V_{INPUT}$  to charge up the flying capacitor  $C_{X(NEG)}$  through diode D3. During the second half-cycle, P2 turns off and N2 turns on, level shifting  $C_{X(NEG)}$  by  $V_{INPUT}$  volts. This connects  $C_{X(NEG)}$  in parallel with reservoir capacitor  $C_{OUT(NEG)}$ . If the voltage across  $C_{OUT(NEG)}$  minus a diode drop is greater than the voltage across  $C_{X(NEG)}$ , charge flows from  $C_{OUT(NEG)}$  to  $C_{X(NEG)}$  until diode D4 turns off. The amount of charge transferred to the output is controlled by the on-resistance of N2, which varies according to the output of the feedback error amplifier. The error amplifier compares the feedback signal (FBN) with a 250mV internal reference and amplifies the difference. If the feedback signal is above the reference, the error-amplifier output increases the supply voltage of N2's gate driver, lowering the on-resistance. Similarly, if the feedback signal is below the reference,

the error-amplifier output reduces the driver supply voltage, increasing the on-resistance.

The negative charge-pump regulator is enabled when  $\overline{SHDN}$  is logic high and REF reaches regulation. Each time it is enabled, the negative charge-pump regulator goes through a soft-start routine by ramping down its internal reference voltage from 5V to 250mV in 128 steps. The soft-start period is 2.73ms (typ), and FBN fault detection is disabled during this period. The soft-start feature effectively limits the inrush current during startup. The MAX8710/MAX8711/MAX8712/MAX8761 also monitor the FBN voltage for undervoltage conditions. If  $V_{FBN}$  is continuously above 700mV (typ) for approximately 44ms, the device latches off.

## Operational Amplifier (MAX8710/MAX8711/MAX8761)

The MAX8710/MAX8711/MAX8761s' operational amplifier features high output current (150mA), fast slew rate (7.5V/ $\mu$ s), and wide bandwidth (12MHz). The operational amplifier is enabled when REF is in regulation and  $\overline{SHDN}$  is logic high. The output of the amplifier (OUTB) is internally pulled to ground through a 1k $\Omega$  resistor in shutdown.

The amplifier is typically used to drive the backplane ( $V_{COM}$ ) of TFT LCD panels. The LCD backplane consists of a distributed series capacitance and resistance, a load that can be easily driven by this operational amplifier. However, if the operational amplifier is used in an application with a pure capacitive load, steps must be taken to ensure stable operation. As the operational amplifier's capacitive load increases, the amplifier's bandwidth decreases, and its gain peaking increases. To ensure stable operation, a 5 $\Omega$  to 50 $\Omega$  resistor can be placed between OUTB and the capacitive load to reduce gain peaking.

The operational amplifier limits short-circuit current to approximately  $\pm 150$ mA if the output is directly shorted to SUPB or to GND. If the short-circuit condition persists, the junction temperature of the IC rises until it trips the IC's thermal-overload protection.

## Reference Voltage (REF)

The reference output is nominally 5V and can source up to 1mA (see the *Typical Operating Characteristics*). Bypass REF with a 0.22 $\mu$ F ceramic capacitor connected between REF and GND. The reference remains enabled in shutdown.

MAX8710/MAX8711/MAX8712/MAX8761

# Low-Cost, Linear-Regulator LCD Panel Power Supplies

## Power-Up Sequence and Shutdown Control

When the MAX8710/MAX8711/MAX8712/MAX8761 are powered up, REF rises with the voltage on IN. After REF reaches regulation and if SHDN is logic high, the linear regulator, operational amplifier, and negative charge-pump regulator are enabled and begin their respective soft-start routines. After the soft-start routines are completed, the fault-protection circuits for the linear regulator and the negative charge-pump regulator are activated.

When the linear regulator is enabled, the positive charge-pump-regulator delay block is enabled. An internal current source starts charging the DLP capacitor. The voltage on DLP linearly rises because of the constant charging current. When  $V_{DLP}$  goes above  $V_{REF} / 2$ , the switch control block is enabled, and the positive charge-pump regulator begins its soft-start. After the positive charge-pump regulator's soft-start is completed, the fault protection of the positive charge-pump regulator is also enabled.

The MAX8710/MAX8711/MAX8712/MAX8761 enter into shutdown when SHDN is pulled low or REF falls below 4.5V. In shutdown, OUTL and OUTB are internally pulled to ground with  $1k\Omega$  resistors, FBN and FBP are internally pulled to ground with  $10\Omega$  resistors, and DLP is pulled to GND through a  $10\Omega$  resistor, discharging  $C_{DLP}$ . In the MAX8710 only, GON is pulled to GND through a  $1k\Omega$  resistor. REF remains on in shutdown. Pulling SHDN high when REF is above 4.5V reactivates the IC. Output fault protection and thermal-overload protection can also turn off the IC's outputs. See the respective sections for details.

## Output Fault Protection

During steady-state operation, if the output of the linear regulator or any of the charge-pump regulator outputs does not exceed its respective fault-detection threshold, the MAX8710/MAX8711/MAX8712/MAX8761 activate an internal fault timer. If any condition or the combination of conditions indicates a continuous fault for the fault-timer duration (44ms typ), the MAX8710/MAX8711/MAX8712/MAX8761 set the fault latch, shutting down all the outputs except the reference. Once the fault condition is removed, cycle the input voltage or toggle SHDN to clear the fault latch and reactivate the device. Each regulator's fault-detection circuit is disabled during the regulator's soft-start time.

## Thermal-Overload Protection

The thermal-overload protection prevents excessive power dissipation from overheating the IC. When the junction temperature exceeds  $+160^{\circ}\text{C}$ , a thermal sensor immediately activates the fault protection, which shuts down all the outputs except the reference, allowing the device to cool down. Once the device cools down by approximately  $15^{\circ}\text{C}$ , the IC restarts automatically.

## Switch Control (MAX8710/MAX8761)

The MAX8710/MAX8761s' switch-control block (Figures 6 and 7) consists of a high-voltage p-channel MOSFET Q1 between SRC and GON, and a common-source-connected p-channel MOSFET pair Q2 between GON and DRN. The MAX8710 switch control block is enabled when  $V_{DLP}$  goes above  $V_{REF} / 2$  and for MAX8761  $V_{DLP}$  has no control on switch control block. Both the MAX8710 and MAX8761 have two different modes of operation.

Activate the first mode by connecting MODE to REF. When CTL is logic high, Q1 turns on and Q2 turns off, connecting GON to SRC. When CTL is logic low, Q1 turns off and Q2 turns on, connecting GON to DRN. GON can then be discharged through a resistor connected between DRN and GND or OUTL. Q2 turns off and stops discharging GON when  $V_{GON}$  reaches 10 times the voltage on THR.

When  $V_{MODE}$  is less than  $0.9 \times V_{REF}$ , the switch-control block works in the second mode. The rising edge of  $V_{CTL}$  turns on Q1 and turns off Q2, connecting GON to SRC. An internal n-channel MOSFET Q5 between MODE and GND is also turned on to discharge an external capacitor between MODE and GND. The falling edge of  $V_{CTL}$  turns off Q5, and an internal  $50\mu\text{A}$  current source starts charging the MODE capacitor. Once  $V_{MODE}$  exceeds  $0.5 \times V_{REF}$ , the switch-control block turns off Q1 and turns on Q2, connecting GON to DRN. GON can then be discharged through a resistor connected between DRN and GND or OUTL. Q2 turns off and stops discharging GON when  $V_{GON}$  reaches 10 times the voltage on THR.



# Low-Cost, Linear-Regulator LCD Panel Power Supplies

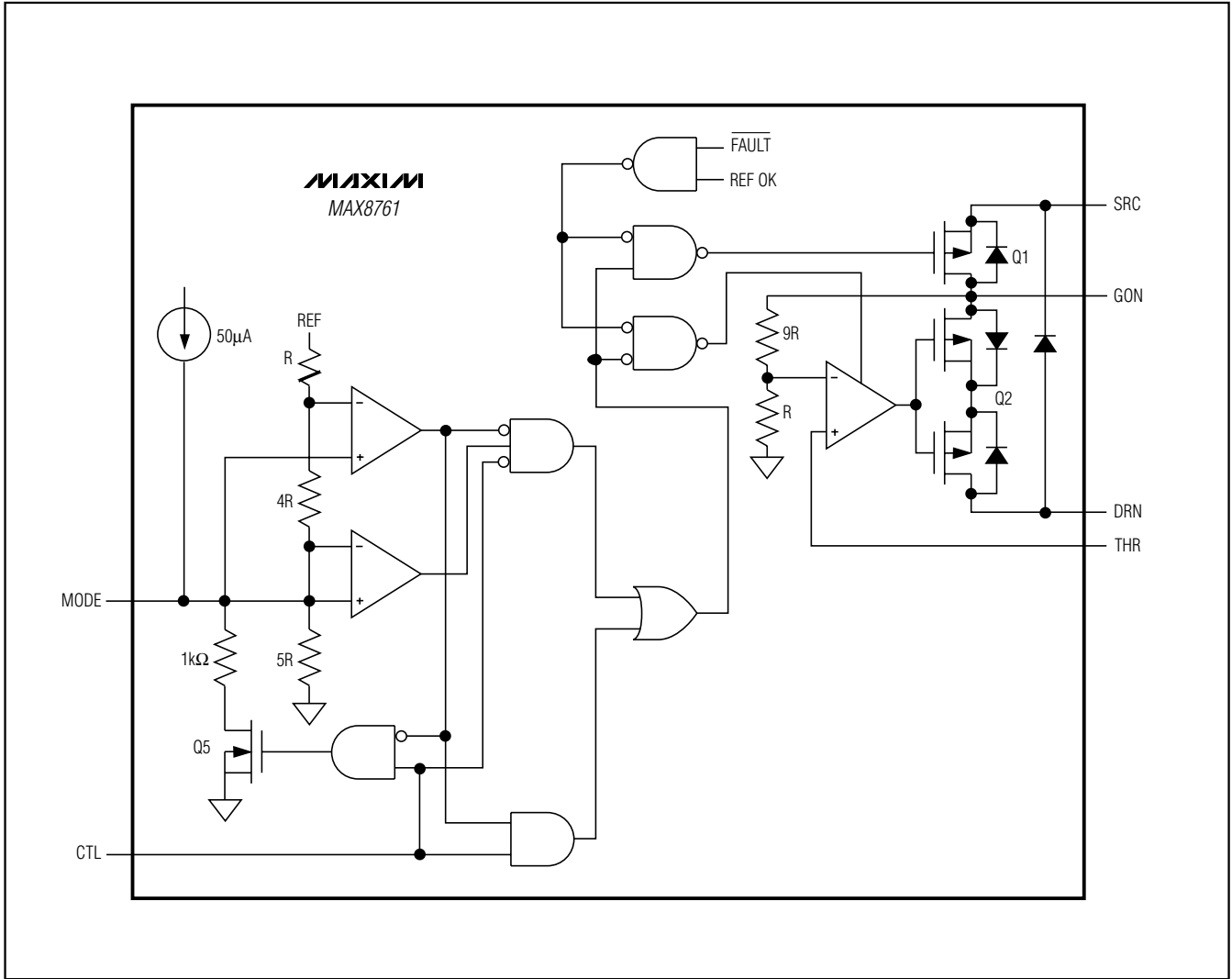

Figure 7. MAX8761 High-Voltage Switch Control

# Low-Cost, Linear-Regulator LCD Panel Power Supplies

MAX8710/MAX8711/MAX8712/MAX8761

## Design Procedure

### Linear Regulator

#### Output-Voltage Selection

Adjust the linear-regulator output voltage by connecting a resistive voltage-divider from the linear-regulator output AVDD to GND with the center tap connected to FBL (Figure 1). Select the lower resistor of divider R2 in the 10kΩ to 50kΩ range. Calculate upper resistor R1 with the following equation:

$$R1 = R2 \times \left( \frac{V_{AVDD}}{V_{FBL}} - 1 \right)$$

where  $V_{FBL} = 2.5V$  (typ) is the regulation point of the linear regulator.

#### Input-Capacitor Selection

The linear regulator's output stage consists of a pnp pass transistor. Rapid movements of the input voltage must be avoided since the movement can be coupled into the base of the transistor through the base-to-emitter junction capacitance. The input capacitor reduces the current peaks drawn from the input supply and slows down the input voltage movement. One 10μF ceramic capacitor is used in the *Typical Operating Circuits* (Figures 1, 2, and 3) because of the high source impedance seen in typical lab setups. Actual applications usually have much lower source impedance, since the linear regulator typically runs directly from the output of another regulated supply and can operate with less input capacitance.

#### Output-Capacitor Selection

The output capacitor and its equivalent series resistance (ESR) affect the linear regulator's stability and transient response. The MAX8710/MAX8711/MAX8712 can deliver at least 300mA continuously and are stable with a 4.7μF output capacitor. The MAX8761 can deliver at least 500mA of output current and is stable with a 10μF output capacitor.

The typical load on the linear regulator for source-driver applications is a large pulsed load, with a peak current of approximately 1A and pulse width of approximately 2μs. The shape of the pulse is close to a triangle, so it is equivalent to a square pulse with 1A height and 1μs pulse width. The total voltage dip during the pulsed load transient also has two components: the ohmic dip due to the output capacitor's ESR, and the capacitive dip caused by discharging the output capacitance:

$$V_{DIP} = V_{DIP(ESR)} + V_{DIP(C)}$$

$$V_{DIP(ESR)} = I_{PULSE} \times R_{ESR}$$

$$V_{DIP(C)} \approx \frac{I_{PULSE} \times t_{PULSE}}{C_{OUT}}$$

where  $I_{PULSE}$  is the height of the pulse load, and  $t_{PULSE}$  is the pulse width. Higher capacitance and lower ESR result in less voltage dip. The ESR dip can be ignored when using ceramic output capacitors. Calculate the minimum required capacitance for the maximum allowed dip using:

$$C_{OUT(MIN)} \approx \frac{I_{PULSE} \times t_{PULSE}}{V_{DIP(MAX)}}$$

The above equations are "worst case" and assume that the linear regulator does not react to correct the output voltage during the load pulse. In fact, the regulator is fast enough to partially correct the output voltage, so the actual dip may be smaller, or a smaller capacitor may be acceptable. For the typical load pulse described above, assuming the voltage dip must be limited to 150mV, the minimum output capacitor is:

$$C_{OUT(MIN)} \approx \frac{1A \times 1\mu s}{0.15V} = 6.7\mu F$$

Because the regulator is able to limit the dip somewhat, the circuit of Figure 1 uses a 4.7μF/10μF (MAX8710/MAX8761) output capacitor. The voltage rating and temperature characteristics of the output capacitor must also be considered.

#### Feed-Forward Compensation

The output capacitance and equivalent load resistance determine the dominant pole. An internal parasitic capacitance of the regulator creates a second pole. This pole typically occurs at 100kHz, but can vary between 60kHz and 140kHz depending on the process variation. Since the pole occurs after the loop gain crossover, it does not affect the loop stability. However, canceling this pole with an additional zero can improve the load-transient response. An additional zero improves the closed-loop phase margin, thereby improving the transient response. The feed-forward network should be designed to get maximum positive phase at unity gain frequency ( $f_u$ ).

A zero can be added by connecting a feed-forward capacitor (C1) between OUTL and FBL as shown in Figure 1. The frequency of the zero can be calculated with the following equation:

## Low-Cost, Linear-Regulator LCD Panel Power Supplies

$$f_{ZERO} = \frac{1}{2\pi R_1 C_1} = \frac{f_U}{\sqrt{V_{OUTL} / V_{FBL}}}$$

where  $R_1$  is the upper resistor of the feedback divider and  $f_U$  is the unity gain frequency. The unity gain frequency ( $f_U$ ) for the MAX8710/MAX8711/MAX8712 is approximately 80kHz; for MAX8761,  $f_U$  is approximately 160kHz. The value of  $R_1$  was calculated in the *Output-Voltage Selection* section to set  $V_{OUTL}$ . Use the value for unity gain frequency ( $f_U$ ), the ratio between  $V_{OUTL}$  and  $V_{FBL}$ , and  $R_1$  to calculate the value of  $C_1$ .

### Charge-Pump Regulators

#### Number of Charge-Pump Stages

For highest efficiency, always choose the lowest number of charge-pump stages that meets the output requirement.

The number of positive charge-pump stages is given by:

$$n_{POS} = \frac{V_P + V_{SWITCH} - V_{SUPCP}}{V_{INPUT} - 2 \times V_{DIODE}}$$

where  $n_{POS}$  is the number of positive charge-pump stages,  $V_P$  is the positive charge-pump regulator output,  $V_{INPUT}$  is the supply voltage for the charge-pump regulators ( $V_{SUPCP}$ , MAX8710/MAX8761 or  $V_{OUTL}$ , MAX8711/MAX8712),  $V_{DIODE}$  is the forward-voltage drop of the charge-pump diode, and  $V_{SWITCH}$  is the voltage drop of the internal switches. Use  $V_{SWITCH} = 0.3V$ .

The number of negative charge-pump stages is given by:

$$n_{NEG} = \frac{-V_{GOFF} + V_{SWITCH}}{V_{INPUT} - 2 \times V_{DIODE}}$$

where  $n_{NEG}$  is the number of negative charge-pump stages and  $V_{GOFF}$  is the negative charge-pump regulator output.

The above equations are derived based on the assumption that the first stage of the positive charge pump is connected to  $V_{MAIN}$  and the first stage of the negative charge pump is connected to ground. Sometimes fractional stages are more desirable for better efficiency. This can be done by connecting the first stage to another available supply, such as a 5V supply. If the first charge-pump stage is powered from 5V, then the above equations become:

$$n_{POS} = \frac{V_P + V_{SWITCH} - 5V}{V_{INPUT} - 2 \times V_{DIODE}}$$

$$n_{NEG} = \frac{-V_{GOFF} + V_{SWITCH} + 5V}{V_{INPUT} - 2 \times V_{DIODE}}$$

### Output-Voltage Selection

Adjust the positive charge-pump-regulator output voltage by connecting a resistive voltage-divider from the regulator output  $V_P$  to GND with the center tap connected to FBP (Figure 1). Select the lower resistor of divider  $R_4$  in the range of 10k $\Omega$  to 50k $\Omega$ . Calculate upper resistor  $R_3$  with the following equation:

$$R_3 = R_4 \times \left( \frac{V_P}{V_{FBP}} - 1 \right)$$

where  $V_{FBP} = 2.5V$  (typ) is the regulation point of the positive charge-pump regulator.

Adjust the negative charge-pump-regulator output voltage by connecting a resistive voltage-divider from the negative charge-pump output  $V_{GOFF}$  to REF with the center tap connected to FBN (Figure 1). Select  $R_6$  in the 20k $\Omega$  to 100k $\Omega$  range. Calculate  $R_5$  with the following equation:

$$R_5 = R_6 \times \frac{V_{FBN} - V_{GOFF}}{V_{REF} - V_{FBN}}$$

where  $V_{REF} = 5V$  and  $V_{FBN} = 250mV$  is the regulation point of the negative charge-pump regulator.

### Flying Capacitor

Increasing the flying-capacitor ( $C_X$ ) value lowers the effective source impedance and increases the output-current capability of the charge pump. Increasing the capacitance indefinitely has a negligible effect on output-current capability because the internal switch resistance and the diode impedance place a lower limit on the source impedance. A 0.1 $\mu F$  ceramic capacitor works well in most low-current applications. The flying capacitor's voltage rating must exceed the following:

$$V_{CX} > n \times V_{INPUT}$$

where  $n$  is the stage number in which the flying capacitor is used, and  $V_{INPUT}$  is the supply voltage for the charge-pump regulators ( $V_{SUPCP}$ , MAX8710/MAX8761 or  $V_{OUTL}$ , MAX8711/MAX8712).

### Charge-Pump Input Capacitor

Use an input capacitor with a value equal to or greater than the flying capacitor. Place the capacitor as close to the IC as possible. Connect the capacitor directly to PGND.

# Low-Cost, Linear-Regulator LCD Panel Power Supplies

## Charge-Pump Output Capacitor

Increasing the output capacitance or decreasing the ESR reduces the output ripple voltage and the peak-to-peak transient voltage. With ceramic capacitors, the output voltage ripple is dominated by the capacitance value. Use the following equation to approximate the required capacitor value:

$$C_{OUT\_CP} \geq \frac{I_{LOAD\_CP}}{2f_{OSC} V_{RIPPLE\_CP}}$$

where  $C_{OUT\_CP}$  is the output capacitor of the charge pump,  $I_{LOAD\_CP}$  is the load current of the charge pump, and  $V_{RIPPLE\_CP}$  is the desired peak-to-peak value of the output ripple.

## Charge-Pump Rectifier Diode

Use low-cost silicon switching diodes with a current rating equal to or greater than two times the average charge-pump input current. If it helps avoid an extra stage, some or all of the diodes can be replaced with Schottky diodes with an equivalent current rating.

## Applications Information

### External Transistor for Higher Current or Power Dissipation

The load current and the voltage difference between the input and output determine the linear regulator's power dissipation as shown in the following equation:

$$P_{DISSIPATION} = (V_{INL} - V_{OUTL}) \times I_{OUTL}$$

For some applications, the input voltage to the linear regulator is from a 19V adapter. To make a 10V output, the voltage across the pass transistor is 9V. In this case, the regulator's power dissipation may exceed the dissipation limit that the package can handle. In some other applications, the load current may be much higher than the regulator's guaranteed 300mA output current for the MAX8710/MAX8711/MAX8712 and 500mA for the MAX8761.

The solution for such applications is to connect an external pnp transistor with the internal pnp transistor in a Darlington configuration as shown in Figure 8. The external pass transistor must be able to handle most of the power dissipation since most of the load current flows through it. On the other hand, the power dissipated in the internal pass transistor is very low. The current-limit circuit does not work if an external pass transistor is used because the linear regulator only senses the current of the internal pass transistor.

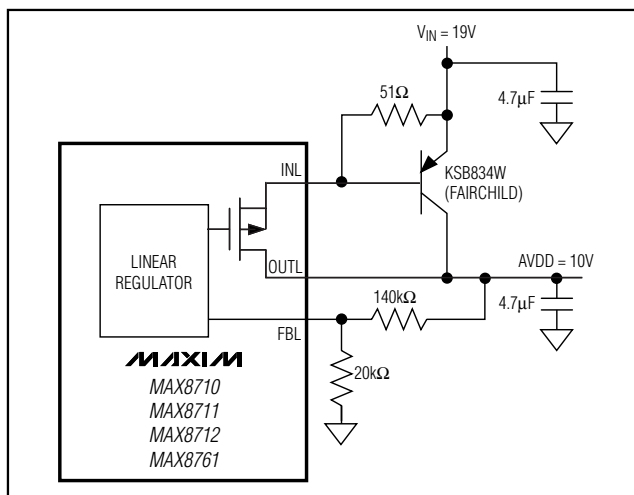

Figure 8. High-Power Linear Regulator

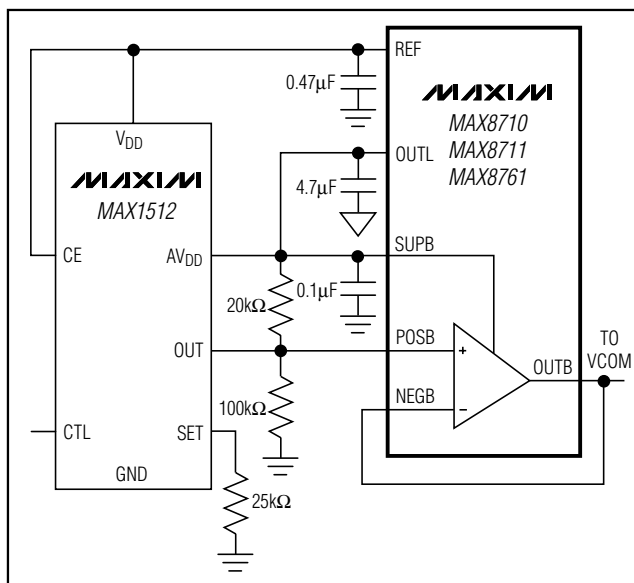

Figure 9. Using the MAX1512 to Adjust the VCOM Buffer Output

### Using the MAX1512 VCOM Calibrator to Adjust the Buffer Output

The operational amplifier is typically used as the VCOM buffer in TFT LCD panels. The output voltage of the VCOM buffer can be adjusted using the MAX1512, which is an EEPROM-programmable VCOM calibrator, using the circuit shown in Figure 9. Refer to the MAX1512 data sheet for details.

MAX8710/MAX8711/MAX8712/MAX8761

# Low-Cost, Linear-Regulator LCD Panel Power Supplies

## PC Board Layout Guidelines

Careful PC board layout is important for proper operation. Use the following guidelines for good PC board layout:

- 1) Create a power ground island consisting of the linear-regulator input and output-capacitor ground connections, the GND pin, and the capacitor ground connections for the charge-pump regulators. Connect all these together with short, wide traces or a small ground plane. Maximizing the width of the power ground traces improves efficiency. Create an analog ground island consisting of all the feedback-divider ground connections, the operational-amplifier divider ground connection, the REF capacitor ground connection, the MODE capacitor ground connection, the DLP capacitor ground connection, and the device's exposed backside pad. Connect the analog ground island and the power ground island by connecting the GND pin directly to the exposed backside pad. Make no other connections between these separate ground islands.
- 2) Place all feedback voltage-divider resistors as close to their respective feedback pins as possible. The divider's center trace should be kept short. Placing the resistors far away causes their FB traces to become antennas that can pick up noise from the switching nodes of the charge pumps. Avoid running any feedback trace near these switching nodes.
- 3) Place IN, INL, SUPB, SUPCP, and REF pin bypass capacitors close to the IC. The ground connection of the IN bypass capacitor should be connected directly to the GND pin with a wide trace.
- 4) Minimize the length and maximize the width of the traces between the output capacitors and the load for best transient responses.
- 5) Minimize the size of the switching nodes (DRVP and DRVN). Keep the switching nodes away from feedback nodes (FBL, FBP, and FBN) and the analog ground. Use DC traces as a shield if necessary.

Refer to the MAX8710 evaluation kit for an example of proper board layout.

## Pin Configurations (continued)

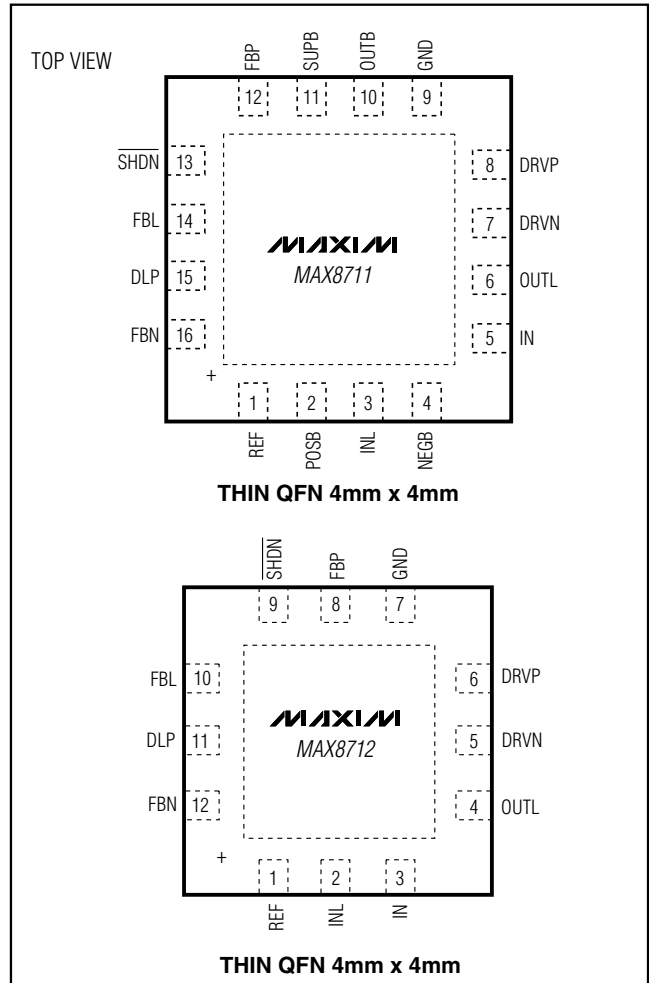

## Chip Information

MAX8710/MAX8711/MAX8712 TRANSISTOR COUNT: 3946

MAX8761 TRANSISTOR COUNT: 4127

PROCESS: BICMOS

# Low-Cost, Linear-Regulator LCD Panel Power Supplies

## Package Information

(The package drawing(s) in this data sheet may not reflect the most current specifications. For the latest package outline information go to [www.maxim-ic.com/packages](http://www.maxim-ic.com/packages).)

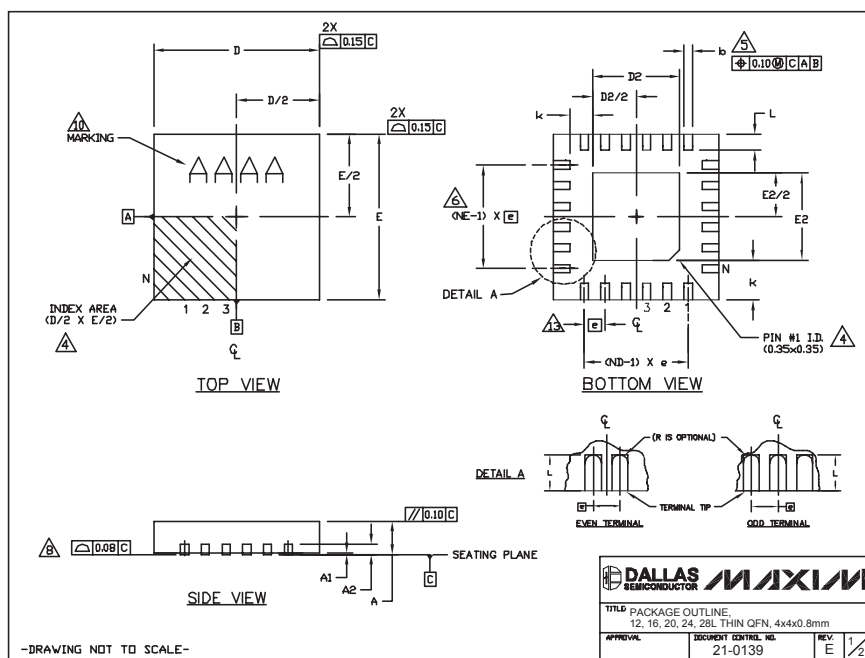

COMMON DIMENSIONS															
PKG REF.	12L 4x4			16L 4x4			20L 4x4			24L 4x4			28L 4x4		
	MIN.	NOM.	MAX.	MIN.	NOM.	MAX.	MIN.	NOM.	MAX.	MIN.	NOM.	MAX.	MIN.	NOM.	MAX.
A	0.70	0.75	0.80	0.70	0.75	0.80	0.70	0.75	0.80	0.70	0.75	0.80	0.70	0.75	0.80
A1	0.0	0.02	0.05	0.0	0.02	0.05	0.0	0.02	0.05	0.0	0.02	0.05	0.0	0.02	0.05
A2	0.20 REF.			0.20 REF.			0.20 REF.			0.20 REF.			0.20 REF.		
b	0.25	0.30	0.35	0.25	0.30	0.35	0.20	0.25	0.30	0.18	0.23	0.30	0.15	0.20	0.25
D	3.90	4.00	4.10	3.90	4.00	4.10	3.90	4.00	4.10	3.90	4.00	4.10	3.90	4.00	4.10
E	3.90	4.00	4.10	3.90	4.00	4.10	3.90	4.00	4.10	3.90	4.00	4.10	3.90	4.00	4.10
e	0.80 BSC.			0.65 BSC.			0.50 BSC.			0.50 BSC.			0.40 BSC.		
k	0.25	-	-	0.25	-	-	0.25	-	-	0.25	-	-	0.25	-	-
L	0.45	0.55	0.65	0.45	0.55	0.65	0.45	0.55	0.65	0.30	0.40	0.50	0.30	0.40	0.50
N	12			16			20			24			28		
ND	3			4			5			6			7		
NE	3			4			5			6			7		
WG6C	WG6B			WG6C			WG6D-1			WG6D-2			WG6E		

EXPOSED PAD VARIATIONS									
PKG CODES	D2			E2			DOWN BONDS ALLOWED		
	MIN.	NOM.	MAX.	MIN.	NOM.	MAX.			
T1244-3	1.95	2.10	2.25	1.95	2.10	2.25	YES		
T1244-4	1.95	2.10	2.25	1.95	2.10	2.25	NO		
T1644-3	1.95	2.10	2.25	1.95	2.10	2.25	YES		
T1644-4	1.95	2.10	2.25	1.95	2.10	2.25	NO		
T2044-2	1.95	2.10	2.25	1.95	2.10	2.25	YES		
T2044-3	1.95	2.10	2.25	1.95	2.10	2.25	NO		
T2444-2	1.95	2.10	2.25	1.95	2.10	2.25	YES		
T2444-3	2.45	2.60	2.63	2.45	2.60	2.63	YES		
T2444-4	2.45	2.60	2.63	2.45	2.60	2.63	NO		
T2844-1	2.50	2.60	2.70	2.50	2.60	2.70	NO		

NOTES:

- DIMENSIONING & TOLERANCING CONFORM TO ASME Y14.5M-1994.
- ALL DIMENSIONS ARE IN MILLIMETERS. ANGLES ARE IN DEGREES.
- N IS THE TOTAL NUMBER OF TERMINALS.

△ THE TERMINAL #1 IDENTIFIER AND TERMINAL NUMBERING CONVENTION SHALL CONFORM TO JEDEC 95-1 SFP-012. DETAILS OF TERMINAL #1 IDENTIFIER ARE OPTIONAL, BUT MUST BE LOCATED WITHIN THE ZONE INDICATED. THE TERMINAL #1 IDENTIFIER MAY BE EITHER A MOLD OR MARKED FEATURE.

△ DIMENSION b APPLIES TO METALLIZED TERMINAL AND IS MEASURED BETWEEN 0.25 mm AND 0.30 mm FROM TERMINAL TIP.

△ ND AND NE REFER TO THE NUMBER OF TERMINALS ON EACH D AND E SIDE RESPECTIVELY.

7. DEPOPULATION IS POSSIBLE IN A SYMMETRICAL FASHION.

△ COPLANARITY APPLIES TO THE EXPOSED HEAT SINK SLUG AS WELL AS THE TERMINALS.

9. DRAWING CONFORMS TO JEDEC MO220, EXCEPT FOR T2444-3, T2444-4 AND T2844-1.

△ MARKING IS FOR PACKAGE ORIENTATION REFERENCE ONLY.

11. COPLANARITY SHALL NOT EXCEED 0.08mm

12. WARPAGE SHALL NOT EXCEED 0.10mm

△ LEAD CENTERLINES TO BE AT TRUE POSITION AS DEFINED BY BASIC DIMENSION "e", ±0.05.

14. NUMBER OF LEADS SHOWN ARE FOR REFERENCE ONLY.

DALLAS SEMICONDUCTOR MAXIM

TITLE PACKAGE OUTLINE  
12, 16, 20, 24, 28L THIN QFN, 4x4x0.8mm

APPROVAL DOCUMENT CONTROL NO. 21-0139 REV E 2/2

-DRAWING NOT TO SCALE-

Maxim cannot assume responsibility for use of any circuitry other than circuitry entirely embodied in a Maxim product. No circuit patent licenses are implied. Maxim reserves the right to change the circuitry and specifications without notice at any time.

25 **Maxim Integrated Products, 120 San Gabriel Drive, Sunnyvale, CA 94086 408-737-7600**

MAX8710/MAX8711/MAX8712/MAX8761

## Looking for pricing, stock, or lifecycle information?

Click below to explore more details on WIN SOURCE:

 [View MAX8761ETG+T on WIN SOURCE](#)

 [Maxim Integrated](#) Information

## Optimize Your Supply Chain with WIN SOURCE Solutions

-  Global Sourcing Solution
-  Obsolete Management
-  Cost Control Management
-  Shortage Management
-  Alternative Solution
-  Excess Inventory Management