



**THE DATASHEET OF
MB3800PNF-G-BND-JN-EFE1**



Description

The MB3800 is a single-channel switching regulator control IC for low voltage applications incorporating a soft start function and short circuit detection function. The device has a low minimum operating voltage of 1.8 V and is ideal for the power supply of battery-operated electronic equipment.

Features

- Wide supply voltage operating range: 1.8 V to 15 V
- Low current consumption: Typically 5.5 mA in operation, 1 μ A or less in stand-by
- High speed operation is possible: Maximum 1 MHz
- The error amplifier gain is set inside the IC, so peripheral components are minimized.
- Incorporates a soft start circuit.
- Incorporates a timer-latch type short circuit detection circuit (SCP).
- Totem-pole type output with adjustable on/off current (for NPN transistors)
- Incorporates a stand-by function.
- Two types of packages (SOP-8 : 2 types)

Application

- LCD monitor/panel
- Power supply module
- Portable apparatus etc.

Contents

Description	1	9. Typical Characteristics	9
Features	1	10. Functional Description	12
Application	1	10.1 Switching Regulator Function	12
1. Pin Assignment	3	10.2 Power Supply Control Function	12
2. Pin Description	3	10.3 Other Functions	13
3. Block Diagram	4	11. Application Example	13
4. Absolute Maximum Ratings	4	12. Notes On Use	14
5. Recommended Operating Conditions	5	13. Ordering Information	14
6. Electrical Characteristics	6	14. RoHS Compliance Information	14
7. Diagram	7	15. Package Dimensions	15
8. How to Set the Time Constant for Soft Start and Short Circuit Detection	8	Document History	17
8.1 Soft Start	8	Sales, Solutions, and Legal Information	18
8.2 Short Circuit Protection	8		

1. Pin Assignment

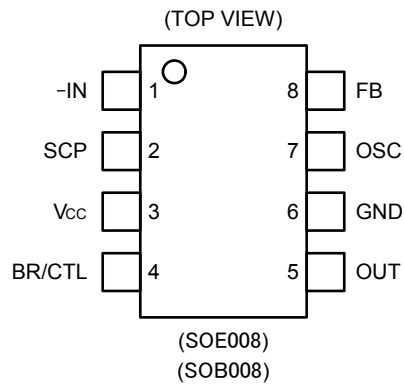

2. Pin Description

Pin No.	Symbol	I/O	Description
1	-IN	I	Error amplifier inverting input pin
2	SCP	—	Soft start and SCP setting capacitor connection pin
3	V _{CC}	—	Power supply pin
4	BR/CTL	I	Output current setting and control pin
5	OUT	O	Totem-pole type output pin
6	GND	—	Ground pin
7	OSC	—	Capacitor and resistor connection pin for setting the oscillation frequency
8	FB	O	Error amplifier output pin

3. Block Diagram

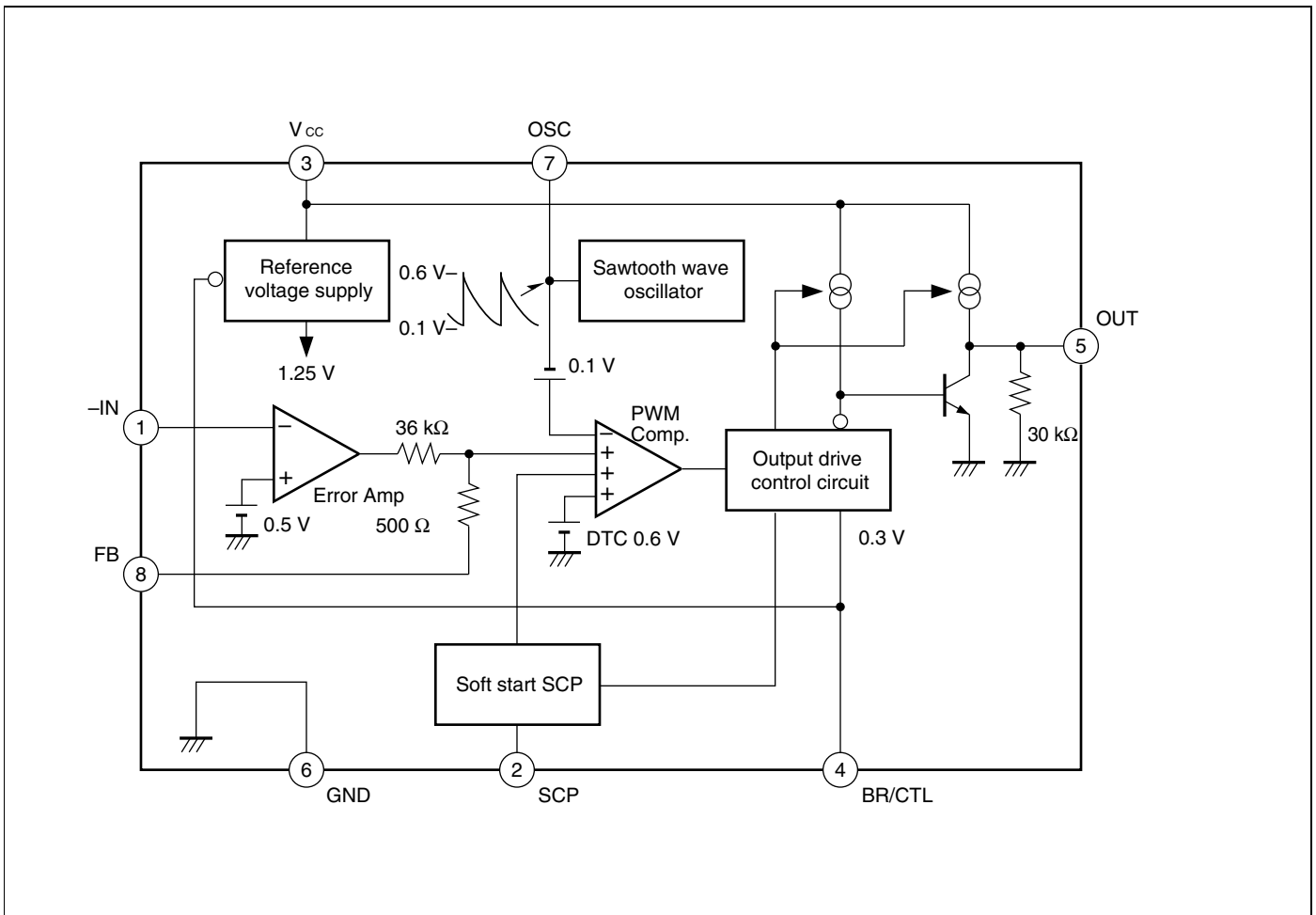

4. Absolute Maximum Ratings

Parameter	Symbol	Condition	Rating		Unit
			Min	Max	
Power supply voltage	V _{CC}	—	—	16	V
Output source current	I _O ⁺	—	—	-50	mA
Output sink current	I _O ⁻	—	—	50	mA
Allowable dissipation	P _D	FPT-8P-M01, T _a ≤ +25°C	—	570*	mW
		FPT-8P-M02, T _a ≤ +25°C	—	430*	mW
		SSOP-8, T _a ≤ +25°C	—	580*	mW
Storage temperature	T _{stg}	—	-55	+125	°C

*: When mounted on a 10 cm square double-sided epoxy board.

WARNING: Semiconductor devices can be permanently damaged by application of stress (voltage, current, temperature, etc.) in excess of absolute maximum ratings. Do not exceed these ratings.

5. Recommended Operating Conditions

(Ta = +25°C)

Parameter	Symbol	Value			Unit
		Min	Typ	Max	
Power supply voltage	V_{CC}	1.8	—	15	V
Error amplifier input voltage	V_I	-0.2	—	+1.0	V
BR/CTL pin input voltage	V_{BR}	-0.2	—	V_{CC}	V
Output source current	I_{O^+}	-40	—	—	mA
Output sink current	I_{O^-}	—	—	40	mA
SCP pin capacitance	C_{PE}	—	0.1	—	μF
Phase compensation capacitance	C_P	—	0.1	—	μF
Output current setting resistance	R_B	150	390	5000	Ω
Timing resistance	R_T	1.0	3.0	10.0	k Ω
Timing capacitance	C_T	100	270	10000	pF
Oscillation frequency	f_{OSC}	10	500	1000	kHz
Operating Ambient temperature	Ta	-30	+25	+85	°C

WARNING: The recommended operating conditions are required in order to ensure the normal operation of the semiconductor device. All of the device's electrical characteristics are warranted when the device is operated within these ranges.

Always use semiconductor devices within their recommended operating condition ranges. Operation outside these ranges may adversely affect reliability and could result in device failure.

No warranty is made with respect to uses, operating conditions, or combinations not represented on the data sheet. Users considering application outside the listed conditions are advised to contact their representatives beforehand.

6. Electrical Characteristics

(VCC = +2 V, Ta = +25°C)

Parameter		Symbol	Condition	Value			Unit	
				Min	Typ	Max		
Circuit to prevent malfunction at low input voltage (U.V.L.O.)	Reset voltage	V_R	—	—	—	0.9	V	
	Threshold voltage	V_{TH}	—	1.1	1.3	1.5	V	
Soft start	Charging current	I_{CS}	$V_{SCP} = 0\text{ V}$	-1.5	-1.0	-0.7	μA	
	Voltage at soft start completion	V_{TS}	—	0.7	0.8	0.9	V	
Short circuit detection (S.C.P.)	Charging current	I_{CPC}	$V_{SCP} = 0\text{ V}$	-1.5	-1.0	-0.7	μA	
	Threshold voltage	V_{IPC}	—	0.7	0.8	0.9	V	
Sawtooth wave oscillator (OSC)	Oscillation frequency	f_{OCS}	$R_T = 3.0\text{ k}\Omega$, $C_T = 270\text{ pF}$	400	500	600	kHz	
	Frequency input stability	f_{dV}	$V_{CC} = 2\text{ V to }15\text{ V}$	—	2	10	%	
	Frequency variation with temperature	f_{dT}	$T_a = -30^\circ\text{C to }+85^\circ\text{C}$	—	5	—	%	
Error amplifier	Input threshold voltage	V_T	$V_{FB} = 450\text{ mV}$	480	500	520	mV	
	V_T input stability	V_{TdV}	$V_{CC} = 2\text{ V to }15\text{ V}$	—	5	20	mV	
	V_T variation with temperature	V_{TdT}	$T_a = -30^\circ\text{C to }+85^\circ\text{C}$	—	1	—	%	
	Input bias current	I_B	$V_{IN} = 0\text{ V}$	-1.0	-0.2	+1.0	μA	
	Voltage gain	A_V	—	70	100	145	V/V	
	Frequency bandwidth	BW	$A_V = 0\text{ dB}$	—	6	—	MHz	
	Maximum output voltage range	V_{OM}^+	—	—	0.78	0.87	—	V
		V_{OM}^-			—	0.05	0.2	V
	Output source current	I_{OM}^+	$V_{FB} = 0.45\text{ V}$	—	—	-40	-24	μA
Output sink current	I_{OM}^-	24			40	—	μA	
Idle period adjustment section	Maximum duty cycle	t_{DUTY}	$R_T = 3.0\text{ k}\Omega$, $C_T = 270\text{ pF}$ $V_{FB} = 0.8\text{ V}$	65	75	85	%	

Parameter		Symbol	Condition	Value			Unit
				Min	Typ	Max	
Output section	Output voltage	V_{OH1}	$R_B = 390 \Omega, I_O = -15 \text{ mA}$	1.0	1.2	—	V
		V_{OH2}	$R_B = 750 \Omega, V_{CC} = 1.8 \text{ V}$ $I_O = -10 \text{ mA}$	0.8	1.0	—	V
		V_{OL1}	$R_B = 390 \Omega, I_O = 15 \text{ mA}$	—	0.1	0.2	V
		V_{OL2}	$R_B = 750 \Omega, V_{CC} = 1.8 \text{ V}$ $I_O = 10 \text{ mA}$	—	0.1	0.2	V
	Output source current	I_O^+	$R_B = 390 \Omega, V_O = 0.9 \text{ V}$	—	-30	-20	mA
	Output sink current	I_O^-	$R_B = 390 \Omega, V_O = 0.3 \text{ V}$	30	60	—	mA
	Pull down resistance	R_O	—	20	30	40	k Ω
Output current setting section/ Control section	Pin voltage	V_{BR}	$R_B = 390 \Omega$	0.2	0.3	0.4	V
	Input off condition	I_{OFF}	—	-20	—	0	μA
	Input on condition	I_{ON}	—	—	-45	μA	
	Pin current range	I_{BR}	—	-1.8	—	-0.1	mA
Entire device	Stand-by current	I_{CCS}	BR/CTL pin open or V_{CC}	—	—	1	μA
	Average supply current	I_{CC}	$R_B = 390 \Omega$	—	5.5	9.3	mA

7. Diagram

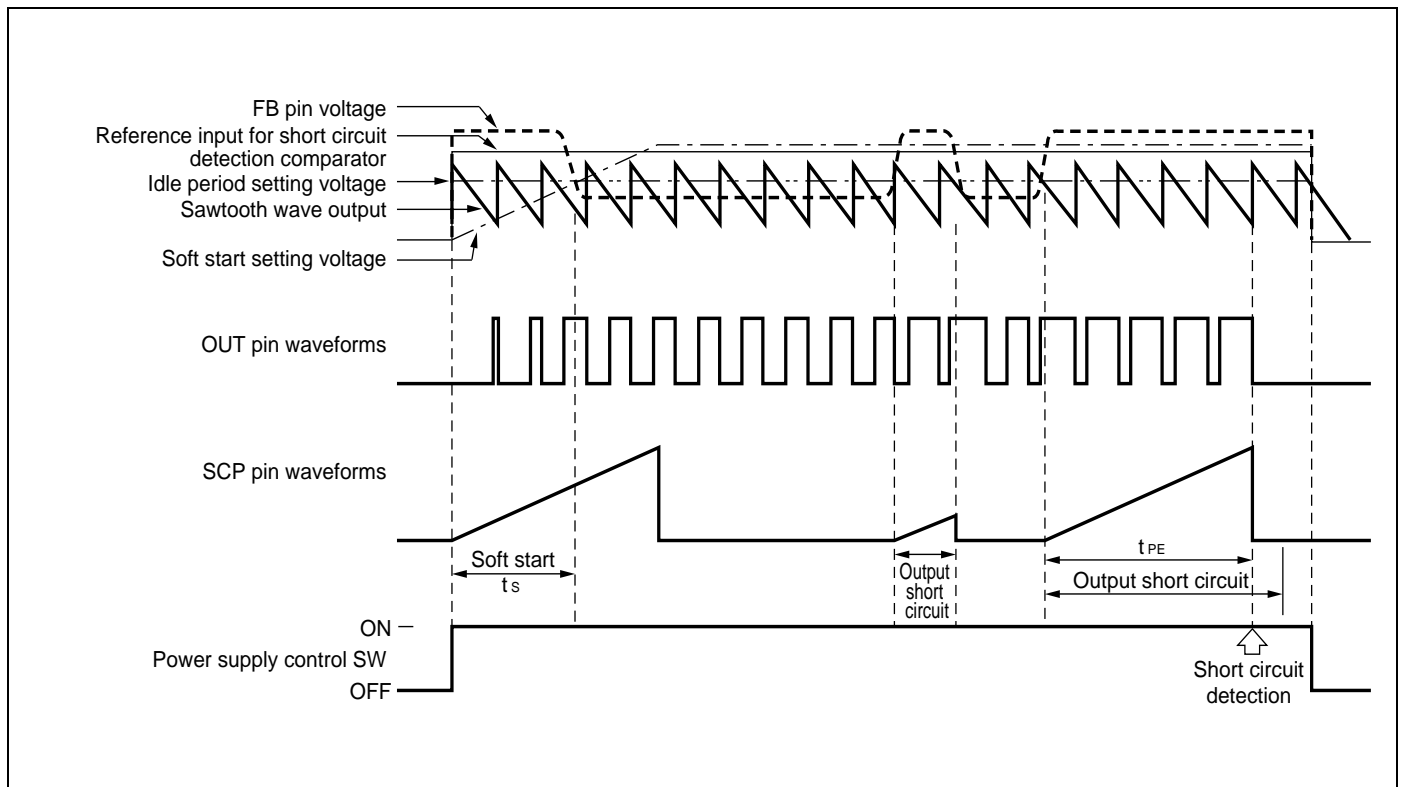

8. How to Set the Time Constant for Soft Start and Short Circuit Detection

8.1 Soft Start

At power on, the capacitor C_{PE} connected to the SCP pin (pin 2) starts charging. The PWM comparator compares the soft start setting voltage as a proportion of the voltage at the SCP pin with the sawtooth waveform.

The comparison controls the ON duty of the OUT pin (pin 5), causing the soft start operation. On completion of soft start operation, the voltage at the SCP pin stays low, the soft start setting voltage stays high, and the circuit enters the output short circuit detection wait state.

Soft start time (The time until the output ON duty reaches approximately 50%)

$$t_S [s] \cong 0.35 \times C_{PE} [\mu F]$$

8.2 Short Circuit Protection

If the switching regulator output suddenly drops due to load effect, the error amplifier output (FB pin (pin 8)) is fixed at V_{OM}^+ and capacitor C_{PE} starts charging. When the voltage at the SCP pin reaches approximately 0.8 V, the OUT pin (pin 5) is set low and the SCP pin (pin 2) stays low.

Once the protection circuit operates, the circuit can be restored by resetting the power supply.

- Short circuit detection time

$$t_{PE} [s] \cong 0.8 \times C_{PE} [\mu F]$$

9. Typical Characteristics

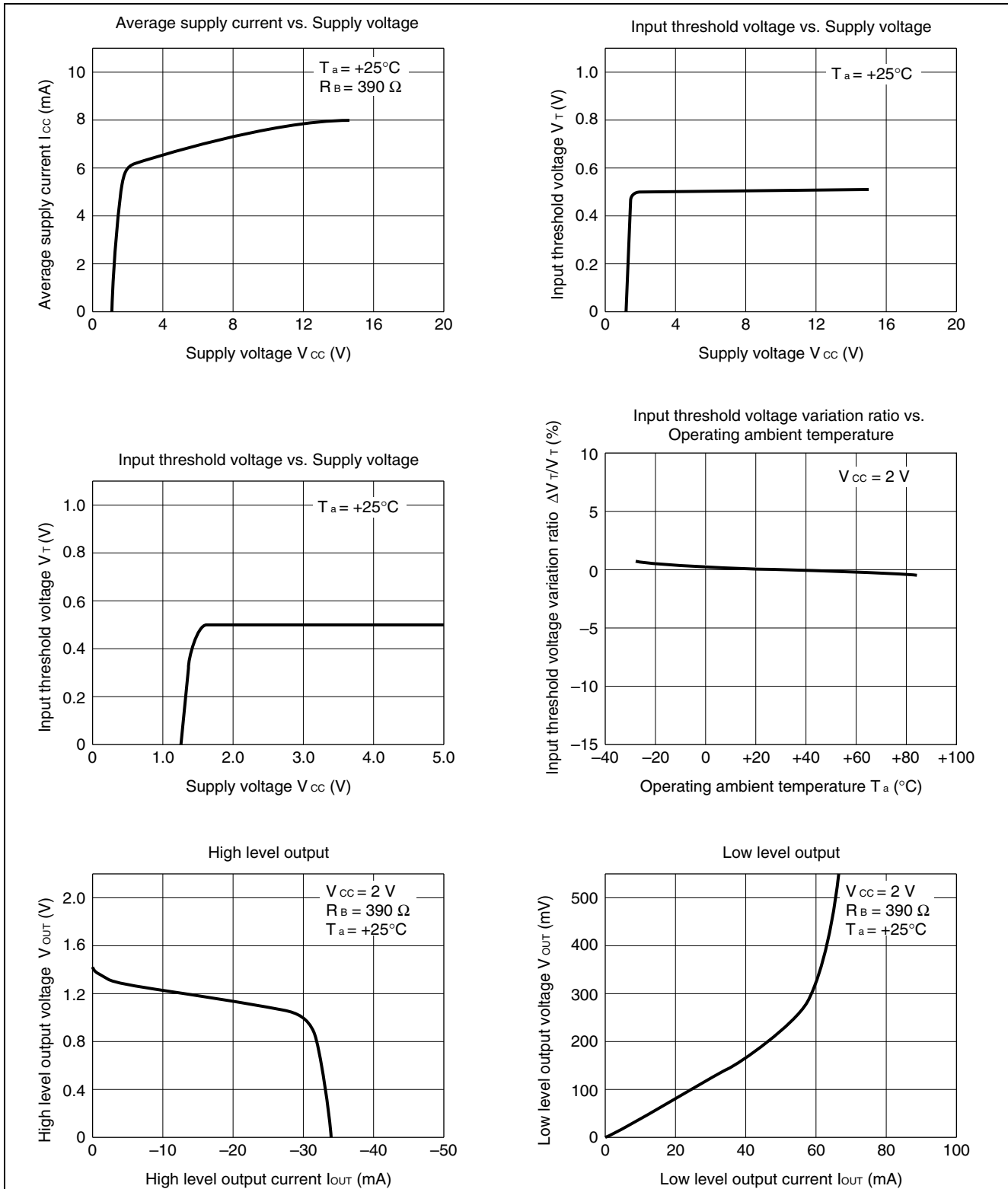

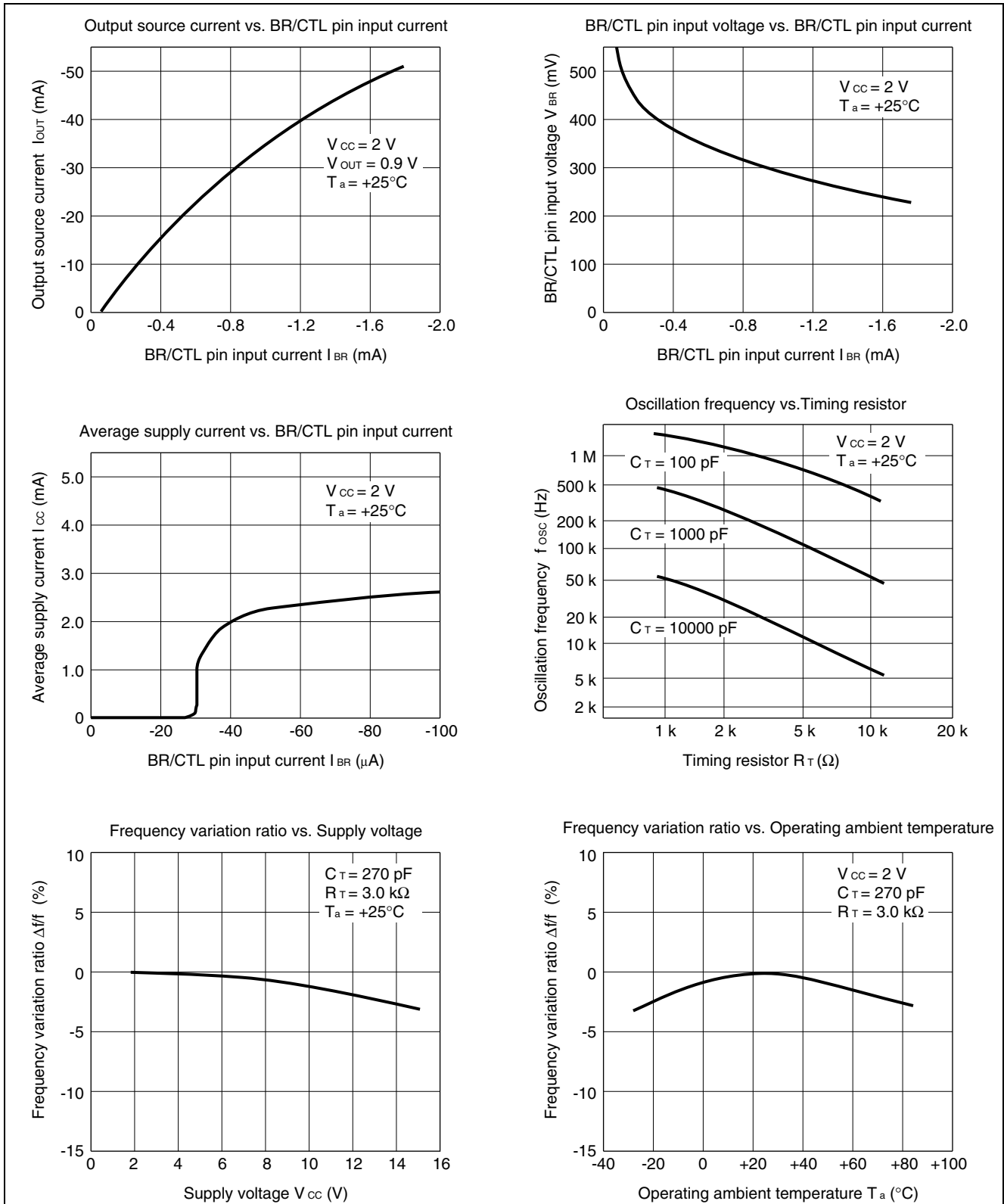

Maximum duty cycle vs. Oscillation frequency

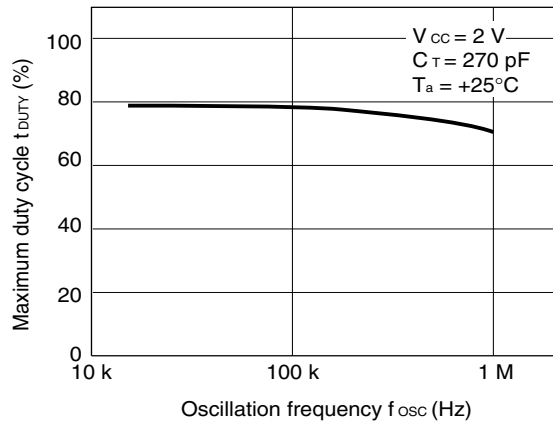

Output pin voltage and current waveforms (reference data)

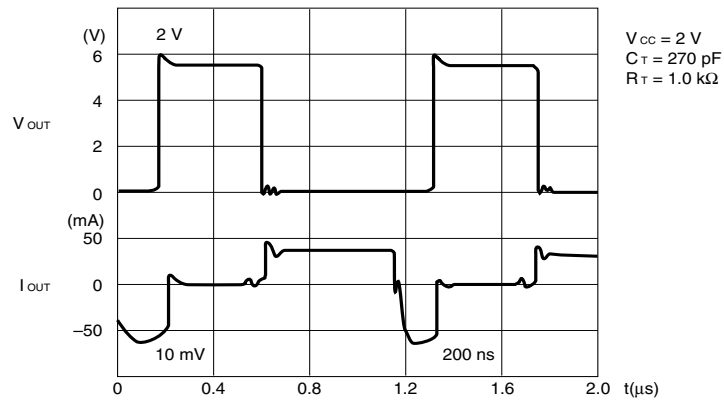

Note: The OFF delay time of V_{OUT} depends on the characteristics of the external transistor.

Measurement circuit diagram

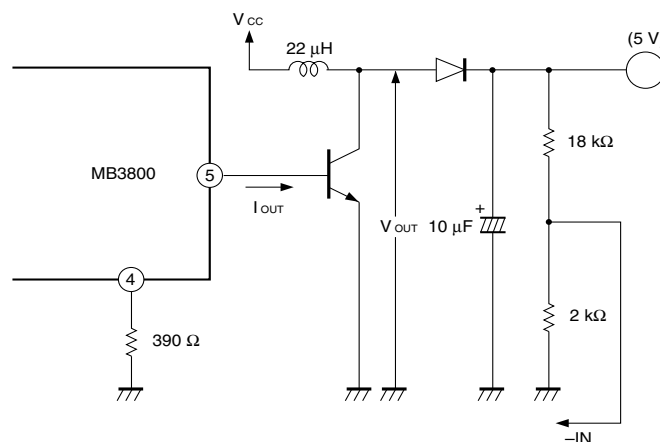

10. Functional Description

10.1 Switching Regulator Function

10.1.1 Reference voltage circuit

The reference voltage circuit generates a temperature-compensated reference voltage ($\approx 1.25V$) from voltage supplied from the V_{CC} pin (pin 3). In addition to providing the reference voltage for the switching regulator, the circuit also sets the idle period.

10.1.2 Sawtooth wave oscillator

The sawtooth oscillator generates a sawtooth wave (up to 1 MHz) that is stable with respect to the supply voltage and temperature. The capacitor and resistor that set the oscillation frequency are connected to the OSC pin (pin 7).

10.1.3 Error amplifier (Error Amp)

The error amplifier detects the output voltage of the switching regulator and outputs the PWM control signal. The voltage gain is fixed, and connecting a phase compensation capacitor to the FB pin (pin 8) provides stable phase compensation for the system.

10.1.4 PWM comparator (PWM Comp.)

The voltage comparator has one inverting and three non-inverting inputs. The comparator is a voltage/pulse width converter that controls the ON time of the output pulse depending on the input voltage. The output level is high (H) when the sawtooth wave is lower than the error amplifier output voltage, soft start setting voltage, and idle period setting voltage.

10.1.5 Output circuit

The output circuit has a totem pole type configuration and can drive an external NPN transistor directly. The value of the ON/OFF current can be set by a resistor connected to the BR/CTL pin (pin 4).

10.2 Power Supply Control Function

Stand-by mode (supply current $1 \mu A$ or less) can be set by connecting the BR/CTL pin (pin 4) to V_{CC} or by making the pin open circuit.

SW	Mode
OFF	Stand-by mode
ON	Operating mode

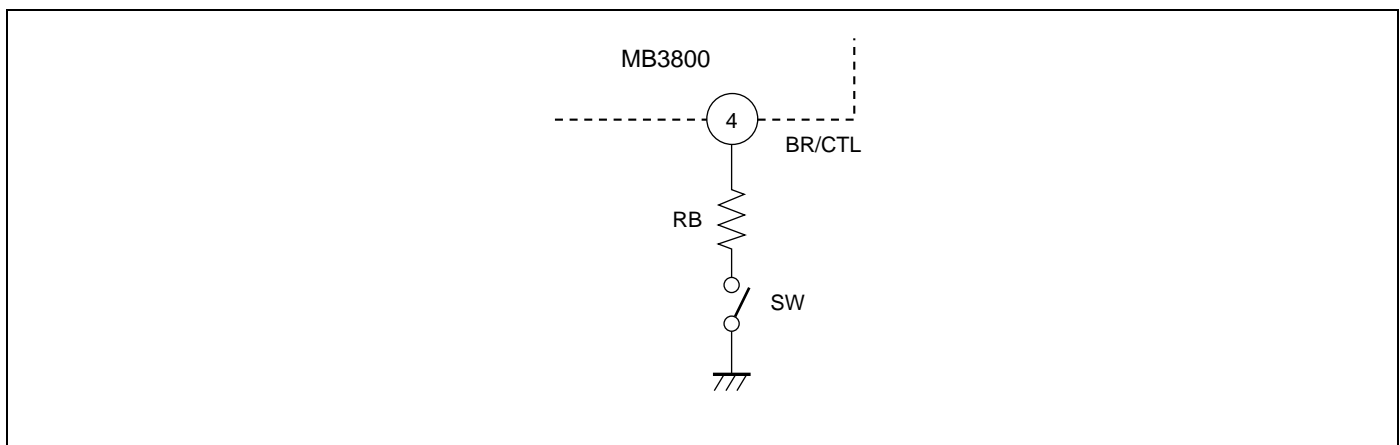

10.3 Other Functions

10.3.1 Soft start and short circuit detection

Soft start operation is set by connecting capacitor C_{PE} to the SCP pin (pin 2). Soft start prevents a current spike on start-up. On completion of soft start operation, the SCP pin (pin 2) stays low and enters the short circuit detection wait state. When an output short circuit occurs, the error amplifier output is fixed at V_{OM+} and capacitor C_{PE} starts charging. After charging to approximately 0.8 V, the OUT pin (pin 5) is set low and the SCP pin (pin 2) stays low. Once the protection circuit operates, the circuit can be restored by resetting the power supply. (See “How to Set the Time Constant for Soft Start and Short Circuit Detection”.)

10.3.2 Circuit to prevent malfunction at low input voltage

Transients when powering on or instantaneous glitches in the supply voltage can lead to malfunction of the control IC and cause system damage or failure. The circuit to prevent malfunction at low input voltage detects a low input voltage by comparing the supply voltage to the internal reference voltage. On detection, the circuit fixes the OUT pin (pin 5) to low.

The system recovers when the supply voltage rises back above the threshold voltage of the malfunction prevention circuit.

11. Application Example

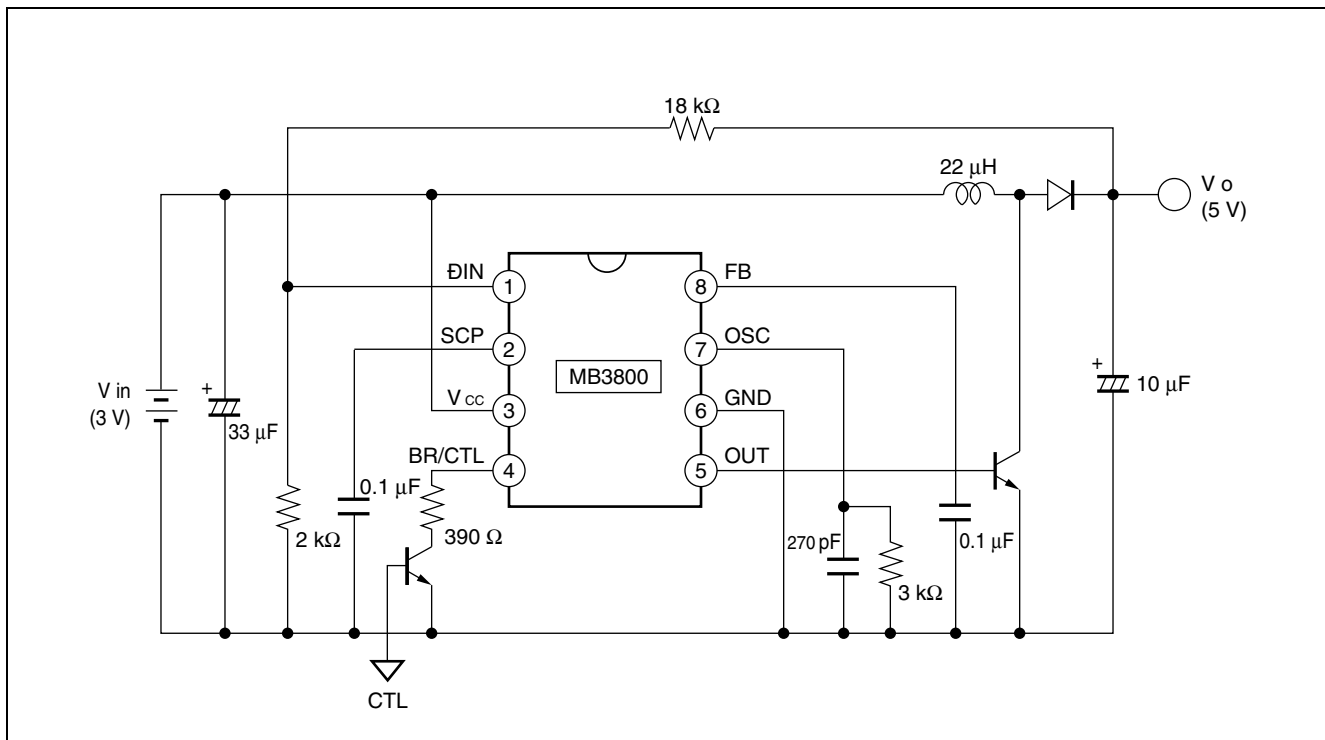

12. Notes On Use

- Take account of common impedance when designing the earth line on a printed wiring board.
- Take measures against static electricity.
 - For semiconductors, use antistatic or conductive containers.
 - When storing or carrying a printed circuit board after chip mounting, put it in a conductive bag or container.
 - The work table, tools and measuring instruments must be grounded.
 - The worker must put on a grounding device containing 250 kΩ to 1 MΩ resistors in series.
- Do not apply a negative voltage
 - Applying a negative voltage of -0.3 V or less to an LSI may generate a parasitic transistor, resulting in malfunction.

13. Ordering Information

Part Number	Package	Remarks
MB3800PF-□□□E1	8-pin Plastic SOP (SOE008)	—
MB3800PNF-□□□E1	8-pin Plastic SOP (SOB008)	—

14. RoHS Compliance Information

The LSI products of Cypress with “E1” are compliant with RoHS Directive , and has observed the standard of lead, cadmium, mercury, Hexavalent chromium, polybrominated biphenyls (PBB) , and polybrominated diphenyl ethers (PBDE) .

The product that conforms to this standard is added “E1” at the end of the part number.

15. Package Dimensions

Package Code: SOE008

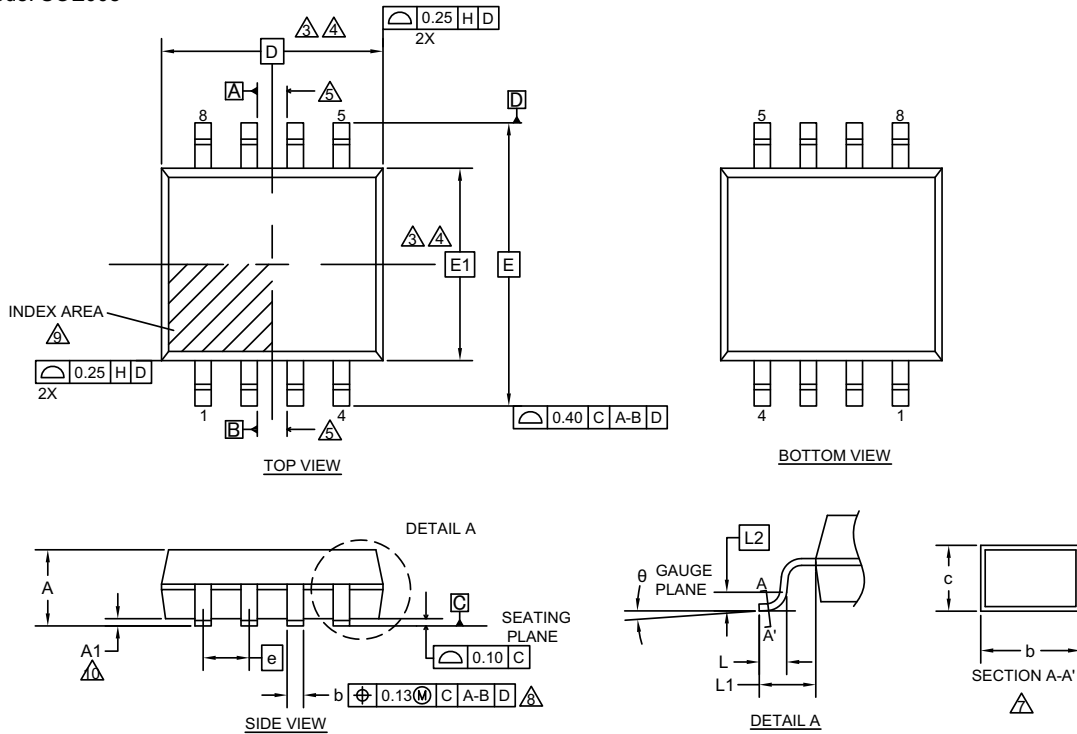

SYMBOL	DIMENSION		
	MIN.	NOM.	MAX.
A	—	—	2.25
A1	0.05	—	0.20
D	6.35 BSC		
E	7.80 BSC		
E1	5.30 BSC		
θ	0°	—	8°
c	0.13	—	0.20
b	0.39	0.47	0.55
L	0.45	0.60	0.75
L 1	1.25 REF		
L 2	0.25 BSC		
e	1.27 BSC		

NOTES

1. ALL DIMENSIONS ARE IN MILLIMETER.
2. DIMENSIONING AND TOLERANCING PER ASME Y14.5M-1994.
3. DIMENSIONING D INCLUDE MOLD FLASH, DIMENSIONING E1 DOES NOT INCLUDE INTERLEAD FLASH OR PROTRUSION. INTERLEAD FLASH OR PROTRUSIONS SHALL NOT EXCEED 0.025 mm PER SIDE. D and E1 DIMENSION ARE DETERMINED AT DATUM H.
4. THE PACKAGE TOP MAY BE SMALLER THAN THE PACKAGE BOTTOM. DIMENSIONING D and E1 ARE DETERMINED AT THE OUTERMOST EXTREMES OF THE PLASTIC BODY EXCLUSIVE OF MOLD FLASH, THE BAR BURRS, GATE BURRS AND INTERLEAD FLASH, BUT INCLUDING ANY MISMATCH BETWEEN THE TOP AND BOTTOM OF THE PLASTIC BODY.
5. DATUMS A & B TO BE DETERMINED AT DATUM H.
6. "N" IS THE MAXIMUM NUMBER OF TERMINAL POSITIONS FOR THE SPECIFIED PACKAGE LENGTH.
7. THE DIMENSION APPLY TO THE FLAT SECTION OF THE LEAD BETWEEN 0.10 mm TO 0.25mm FROM THE LEAD TIP.
8. DIMENSION "b" DOES NOT INCLUDE THE DAMBAR PROTRUSION. ALLOWABLE DAMBAR PROTRUSION SHALL BE 0.10mm TOTAL IN EXCESS OF THE "b" DIMENSION AT MAXIMUM MATERIAL CONDITION. THE DAMBAR MAY NOT BE LOCATED ON THE LOWER RADIUS OF THE FOOT.
9. THIS CHAMFER FEATURE IS OPTIONAL. IF IT IS NOT PRESENT, THEN A PIN 1 IDENTIFIER MUST BE LOCATED WITHIN THE INDEX AREA INDICATED
10. "A1" IS DEFINED AS THE VERTICAL DISTANCE FROM THE SEATING PLANE TO THE LOWEST POINT ON THE PACKAGE BODY EXCLUDING THE LID AND OR THERMAL ENHANCEMENT ON CAVITY DOWN PACKAGE CONFIGURATIONS.
11. JEDEC SPECIFICATION NO. REF : N/A

002-15857 Rev. **

Package Code: SOB008

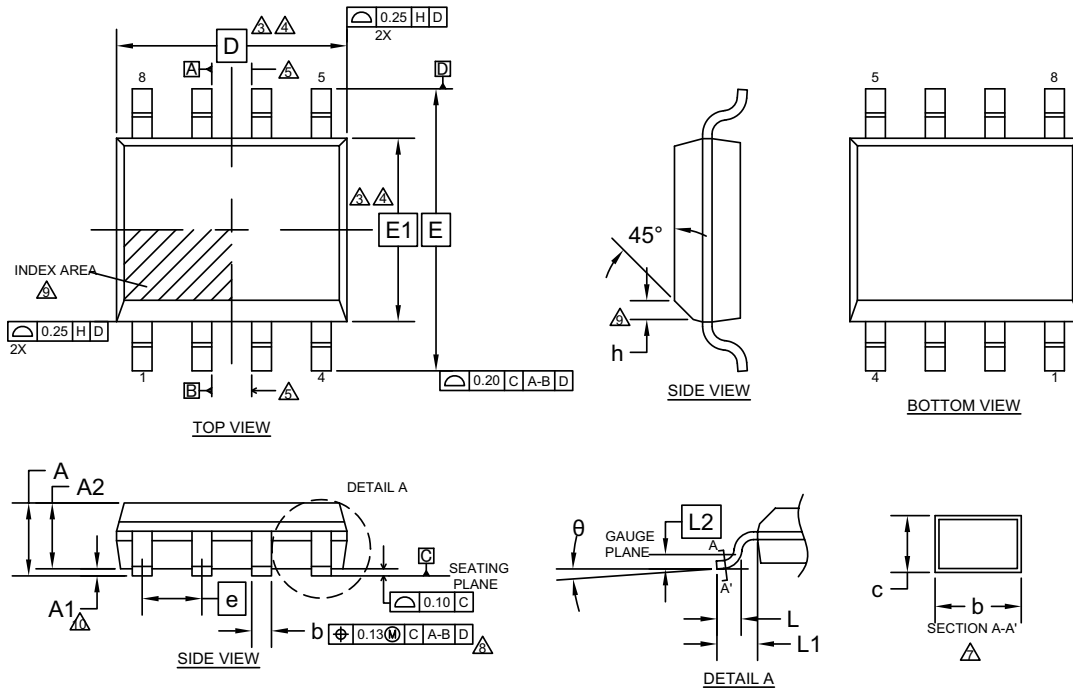

SYMBOL	DIMENSIONS		
	MIN.	NOM.	MAX.
A	—	—	1.75
A1	0.05	—	0.25
A2	1.30	1.40	1.50
D	5.05 BSC.		
E	6.00 BSC.		
E1	3.90 BSC		
θ	0°	—	8°
c	0.15	—	0.25
b	0.36	0.44	0.52
L	0.45	0.60	0.75
L 1	1.05 REF		
L 2	0.25 BSC		
e	1.27 BSC.		
h	0.40 BSC.		

NOTES

- ALL DIMENSIONS ARE IN MILLIMETER.
- DIMENSIONING AND TOLERANCING PER ASME Y14.5M-1994.
- \triangle DIMENSIONING D INCLUDE MOLD FLASH, DIMENSIONING E1 DOES NOT INCLUDE INTERLEAD FLASH OR PROTRUSION. INTERLEAD FLASH OR PROTRUSIONS SHALL NOT EXCEED 0.025 mm PER SIDE. D and E1 DIMENSION ARE DETERMINED AT DATUM H.
- \triangle THE PACKAGE TOP MAY BE SMALLER THAN THE PACKAGE BOTTOM. DIMENSIONING D and E1 ARE DETERMINED AT THE OUTERMOST EXTREMES OF THE PLASTIC BODY EXCLUSIVE OF MOLD FLASH, THE BAR BURRS, GATE BURRS AND INTERLEAD FLASH, BUT INCLUDING ANY MISMATCH BETWEEN THE TOP AND BOTTOM OF THE PLASTIC BODY.
- \triangle DATUMS A & B TO BE DETERMINED AT DATUM H.
- "N" IS THE MAXIMUM NUMBER OF TERMINAL POSITIONS FOR THE SPECIFIED PACKAGE LENGTH.
- \triangle THE DIMENSION APPLY TO THE FLAT SECTION OF THE LEAD BETWEEN 0.10 mm TO 0.25mm FROM THE LEAD TIP.
- \triangle DIMENSION "b" DOES NOT INCLUDE THE DAMBAR PROTRUSION. ALLOWABLE DAMBAR PROTRUSION SHALL BE 0.10mm TOTAL IN EXCESS OF THE "b" DIMENSION AT MAXIMUM MATERIAL CONDITION. THE DAMBAR MAY NOT BE LOCATED ON THE LOWER RADIUS OF THE FOOT.
- \triangle THIS CHAMFER FEATURE IS OPTIONAL. IF IT IS NOT PRESENT, THEN A PIN 1 IDENTIFIER MUST BE LOCATED WITHIN THE INDEX AREA INDICATED
- \triangle "A1" IS DEFINED AS THE VERTICAL DISTANCE FROM THE SEATING PLANE TO THE LOWEST POINT ON THE PACKAGE BODY EXCLUDING THE LID AND OR THERMAL ENHANCEMENT ON CAVITY DOWN PACKAGE CONFIGURATIONS.
- JEDEC SPECIFICATION NO. REF : N/A

002-15856 Rev. **

Document History

Spansion Publication Number: DS04-27212-4Ea

Document Title:MB3800 Switching Regulator Controller Document Number: 002-08716				
Revision	ECN	Orig. of Change	Submission Date	Description of Change
**	-	TAOA	05/10/2006	Migrated to Cypress and assigned document number 002-08716. No change to document contents or format.
*A	5171075	TAOA	03/15/2016	Updated to Cypress format. Deleted FPT-8P-M03.
*B	5731413	HIXT	04/21/2017	Updated Pin Assignment : Change the package name from FPT-8P-M01 to SOE008 Change the package name from FPT-8P-M02 to SOB008 Updated Ordering Information : Change the package name from FPT-8P-M01 to SOE008 Change the package name from FPT-8P-M02 to SOB008 Deleted the part numbers, MB3800PF- □□□ and MB3800PNF- □□□ Deleted the words in the Remarks, "Lead Free version" Updated Package Dimensions : Updated to Cypress format Deleted "Marking Format (Lead Free version)" Deleted "Labeling Sample (Lead free version)" Deleted "MB3800PF- □□□ E1, MB3800PNF- □□□ E1, Recommended Conditions of Moisture Sensitivity Level"

Sales, Solutions, and Legal Information

Worldwide Sales and Design Support

Cypress maintains a worldwide network of offices, solution centers, manufacturer's representatives, and distributors. To find the office closest to you, visit us at [Cypress Locations](#).

Products

ARM® Cortex® Microcontrollers	cypress.com/arm
Automotive	cypress.com/automotive
Clocks & Buffers	cypress.com/clocks
Interface	cypress.com/interface
Internet of Things	cypress.com/iot
Memory	cypress.com/memory
Microcontrollers	cypress.com/mcu
PSoC	cypress.com/psoc
Power Management ICs	cypress.com/pmic
Touch Sensing	cypress.com/touch
USB Controllers	cypress.com/usb
Wireless/RF	cypress.com/wireless

PSoC® Solutions

[PSoC 1](#) | [PSoC 3](#) | [PSoC 4](#) | [PSoC 5LP](#) | [PSoC 6](#)

Cypress Developer Community

[Forums](#) | [WICED IOT Forums](#) | [Projects](#) | [Video](#) | [Blogs](#) | [Training](#) | [Components](#)

Technical Support

cypress.com/support

ARM and Cortex are the registered trademarks of ARM Limited in the EU and other countries.

© Cypress Semiconductor Corporation, 1994-2017. This document is the property of Cypress Semiconductor Corporation and its subsidiaries, including Spansion LLC ("Cypress"). This document, including any software or firmware included or referenced in this document ("Software"), is owned by Cypress under the intellectual property laws and treaties of the United States and other countries worldwide. Cypress reserves all rights under such laws and treaties and does not, except as specifically stated in this paragraph, grant any license under its patents, copyrights, trademarks, or other intellectual property rights. If the Software is not accompanied by a license agreement and you do not otherwise have a written agreement with Cypress governing the use of the Software, then Cypress hereby grants you a personal, non-exclusive, nontransferable license (without the right to sublicense) (1) under its copyright rights in the Software (a) for Software provided in source code form, to modify and reproduce the Software solely for use with Cypress hardware products, only internally within your organization, and (b) to distribute the Software in binary code form externally to end users (either directly or indirectly through resellers and distributors), solely for use on Cypress hardware product units, and (2) under those claims of Cypress's patents that are infringed by the Software (as provided by Cypress, unmodified) to make, use, distribute, and import the Software solely for use with Cypress hardware products. Any other use, reproduction, modification, translation, or compilation of the Software is prohibited.

TO THE EXTENT PERMITTED BY APPLICABLE LAW, CYPRESS MAKES NO WARRANTY OF ANY KIND, EXPRESS OR IMPLIED, WITH REGARD TO THIS DOCUMENT OR ANY SOFTWARE OR ACCOMPANYING HARDWARE, INCLUDING, BUT NOT LIMITED TO, THE IMPLIED WARRANTIES OF MERCHANTABILITY AND FITNESS FOR A PARTICULAR PURPOSE. To the extent permitted by applicable law, Cypress reserves the right to make changes to this document without further notice. Cypress does not assume any liability arising out of the application or use of any product or circuit described in this document. Any information provided in this document, including any sample design information or programming code, is provided only for reference purposes. It is the responsibility of the user of this document to properly design, program, and test the functionality and safety of any application made of this information and any resulting product. Cypress products are not designed, intended, or authorized for use as critical components in systems designed or intended for the operation of weapons, weapons systems, nuclear installations, life-support devices or systems, other medical devices or systems (including resuscitation equipment and surgical implants), pollution control or hazardous substances management, or other uses where the failure of the device or system could cause personal injury, death, or property damage ("Unintended Uses"). A critical component is any component of a device or system whose failure to perform can be reasonably expected to cause the failure of the device or system, or to affect its safety or effectiveness. Cypress is not liable, in whole or in part, and you shall and hereby do release Cypress from any claim, damage, or other liability arising from or related to all Unintended Uses of Cypress products. You shall indemnify and hold Cypress harmless from and against all claims, costs, damages, and other liabilities, including claims for personal injury or death, arising from or related to any Unintended Uses of Cypress products.

Cypress, the Cypress logo, Spansion, the Spansion logo, and combinations thereof, WICED, PSoC, CapSense, EZ-USB, F-RAM, and Traveo are trademarks or registered trademarks of Cypress in the United States and other countries. For a more complete list of Cypress trademarks, visit cypress.com. Other names and brands may be claimed as property of their respective owners.

Looking for pricing, stock, or lifecycle information?

Click below to explore more details on WIN SOURCE:

- ⊖ [View MB3800PNF-G-BND-JN-EFE1 on WIN SOURCE](#)
- ⊖ [Infineon Technologies Information](#)

Optimize Your Supply Chain with WIN SOURCE Solutions

- ✓ Global Sourcing Solution
- ✓ Obsolete Management
- ✓ Cost Control Management
- ✓ Shortage Management
- ✓ Alternative Solution
- ✓ Excess Inventory Management