

Synchronous Rectification 2-Channel DC/DC Converter IC MB39C011

A synchronous rectification 2-channel DC/DC converter IC adopting the PWM type. It operates at a maximum of 2MHz with two built-in channels in TSSOP-16 and QFN-24 and contributes to coil and capacitor miniaturization. The power-supply voltage range is wide (4.5V to 17V), making it optimal for electronic devices including digital AV devices.

Overview

FUJITSU has devoted its efforts to switching-type built-in power-supply ICs and has already developed many models. As a new product of synchronous rectification 2-channel power-supply IC, we have developed “MB39C011”, a synchronous rectification 2-channel DC/DC converter IC that can support a power-supply voltage range of 4.5V to 17V.

This product incorporates two channels in TSSOP-16 and QFN-24 and is capable of operating at 2MHz at maximum,

contributing to the miniaturization of coils and capacitors. Thanks to Pch/Nch MOS FET-type synchronous rectification, use is possible with synchronous rectification when output voltage is low and with asynchronous rectification when output voltage is relatively high. For use with synchronous rectification, the flyback diode can be removed. Output voltage can be set to an optional value by using an external resistor. In addition, it is equipped with a soft-start function that prevents inrush current at power-supply startup with optional setting of power-supply startup time that does not

Photo 1 External View (TSSOP-16)

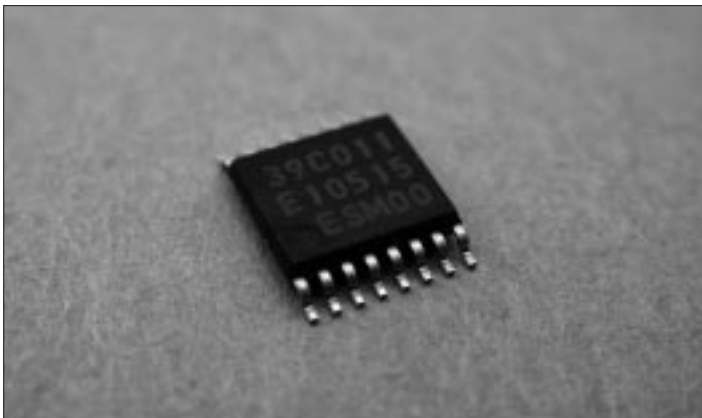
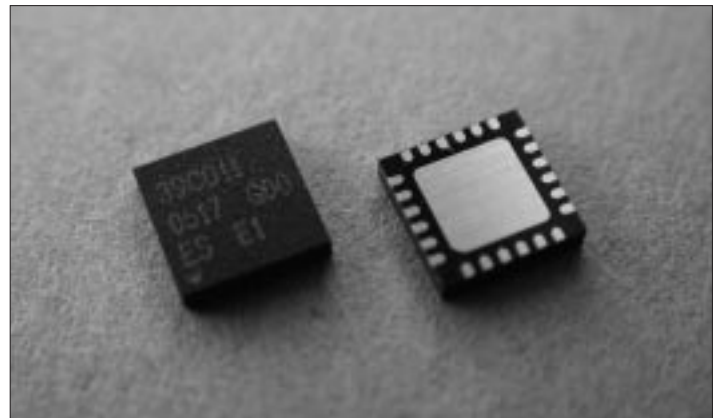

Photo 2 External View (QFN-24)



depend on output load. It also incorporates a timer latch short-circuit protection circuit as a protective function. With such features, this product is optimal for various electronic devices including digital AV devices.

Product Features

- Wide power-supply voltage range: 4.5V to 17V
- For high frequency operation supported: 2MHz (Max.)
- For synchronous rectification type supported (CH1, CH2)
- Any output voltage setting by external resistor
- Built-in standby function: 0μA (Typ.)
- Low current consumption: 1.6mA (Typ., at quiescence condition)
- Built-in soft-start circuit that allows independent control of each channel without load dependency (dual function as capacitance for soft-start)
- Built-in totem-pole-type output for Pch/Nch external

Figure 1 Pin Assignments (TSSOP-16)

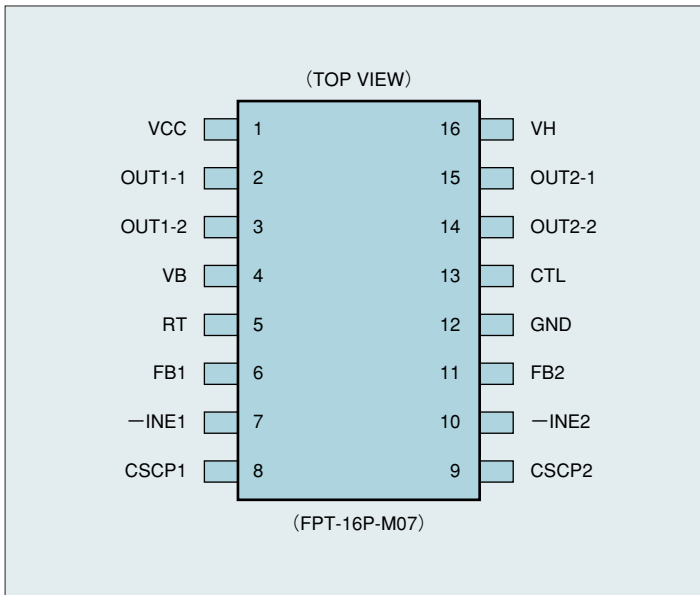

MOS FET

- Package: TSSOP-16, QFN-24

Circuit configuration

Figs.1 and 2 illustrate the pin assignments and Figs.3 and 4 are block diagrams of TSSOP-16 and QFN-24, respectively. This product is composed of the following functional blocks:

DC/DC converter function

■ Triangular wave oscillator block (OSC)

The triangular wave oscillator block incorporates a capacitor for oscillation frequency setup. It generates a triangular wave oscillation waveform by connecting a resistor for setting the triangular wave oscillation frequency at the RT terminal. A triangular wave is input to the PWM comparator in the IC.

■ Error amplifier block (Error Amp1, 2)

Error amplifiers (Error Amp1, 2) are amplifiers that detect the DC/DC converter output voltage and output PWM control signals. Any output voltage can be set up by connecting an external output voltage setting resistor to the error amplifier inverted input terminal.

Stable phase compensation against the system can be attained by setting up an optional loop gain through a

Figure 2 Pin Assignments (QFN-24)

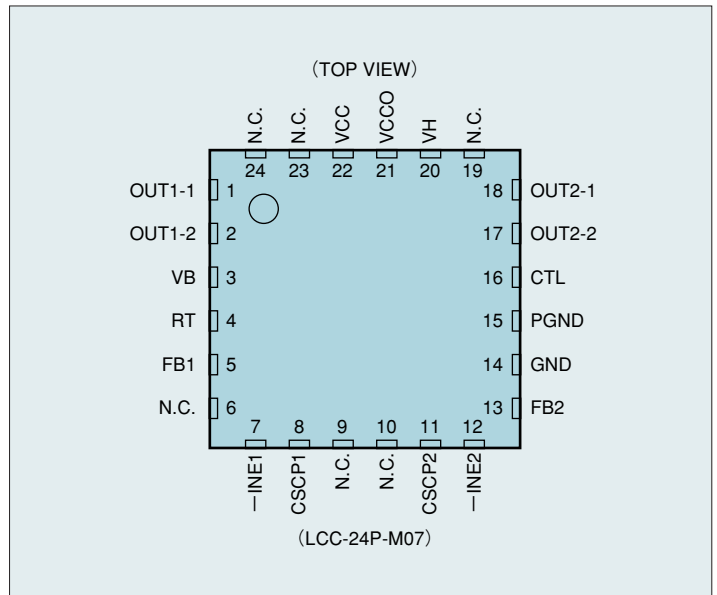

connection of the feedback resistor and capacitor from the Error Amp output (FB1 terminal, FB2 terminal) to the inverted input terminal (-INE1 terminal, -INE2 terminal).

By connecting a capacitor for soft-start to CSCP1 and 2 terminals, the noninverted input terminals of the error amplifier, inrush current at power startup can be eliminated. By executing soft-start detection with an error amplifier, it operates with a stable soft-start time independent from the DC/DC converter output load.

PWM comparator block (PWM Comp.)

The PWM comparator is a voltage-pulse width modulation that controls the output duty depending on the output voltage of the error amplifier (Error Amp1, 2). The output transistor is turned ON when the triangular wave voltage generated by the triangular wave oscillator is lower than the error amplifier output voltage.

Output block (Drive1-1, 1-2, Drive2-1, 2-2)

The output circuit has CMOS-style construction on both

Figure 3 Block Diagram (TSSOP-16)

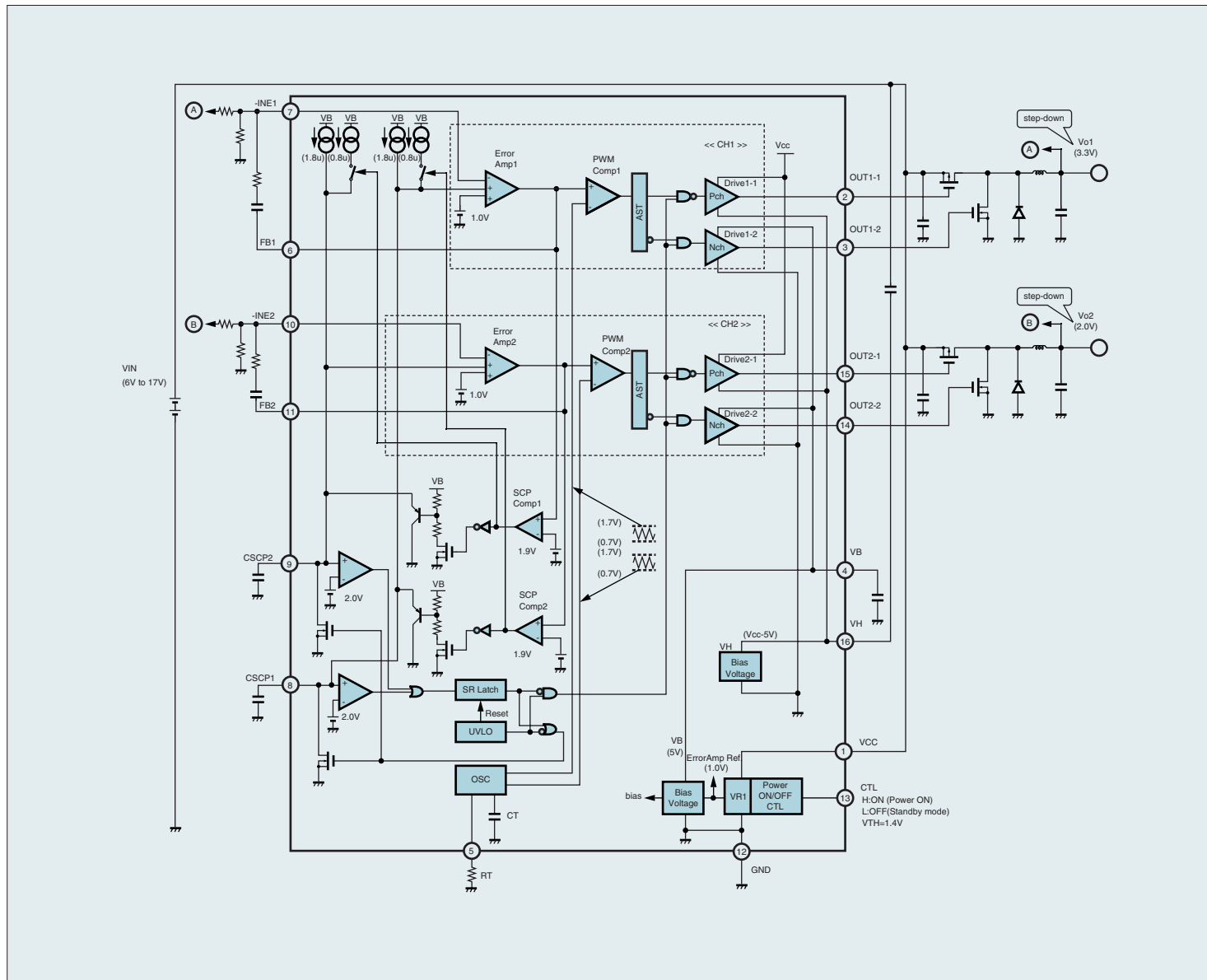

the main and synchronous rectification sides. The main side is capable of driving an external Pch MOS FET while the synchronous rectification side can drive an external Nch MOS FET.

Power-supply control block (CTL)

The system goes into standby status by setting the CTL terminal to “L” level (power-supply current at standby $10\mu A$ Max.). The DC/DC converter block can be put into operation status by setting the CTL terminal to “H” level.

Table 1 presents a list of control functions.

Protective functions

Timer latch short-circuit protection circuit block (SCP Comp.)

Each channel uses the short-circuit protection comparator (SCP Comp.1, 2) to continuously compare the error amplifier output level and the reference voltage. When the load conditions of the DC/DC converter are stable, there is no output fluctuation for error amplifiers; in this way, the short-

Figure 4 Block Diagram (QFN-24)

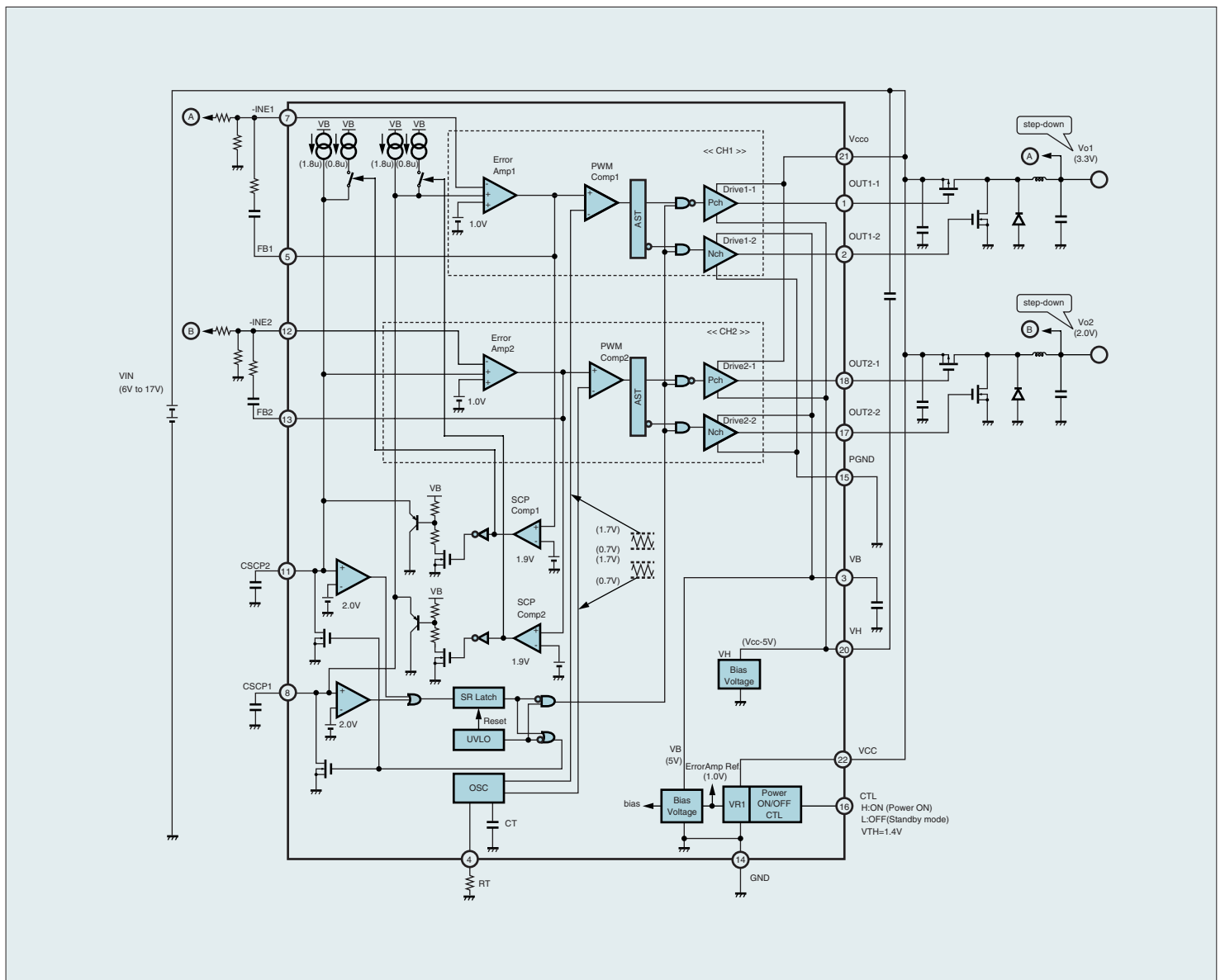

circuit protection comparators also keep their balance. At this time, CSCP1 and 2 terminals are retained at their soft-start completion voltage (approximately 1.3V). When the load conditions change drastically by load short-circuit, etc. and the DC/DC converter output decreases, capacitors CSCP1 and 2 are further charged once the error amplifier output reaches 1.9V or higher. Latch is set when capacitors CSCP1 and 2 are charged to approximately 2.0V and the Pch/Nch external MOS FET is turned OFF (dead time is set to 100%). At this point, latch input is closed and CSCP1 and 2 terminals are maintained at “L” level. When the protection circuit operates, it can be reset by restarting the power supply to set the VB terminal input to 3.3V (Min.) or lower.

Table 1 Table of Control Functions

CTL	IC
L	OFF (standby)
H	ON (operating)

Table 2 Table of Functions under Protective Circuit (UVLO) Operation

When UVLO is operating (VB voltage is below the UVLO threshold voltage), logics for the following terminals become fixed.

OUT1-1	OUT1-2	OUT2-1	OUT2-2	CSCP1	CSCP2
H	L	H	L	L	L

■ Undervoltage lockout protection circuit block (UVLO)

Momentary drops in the power-supply voltage may cause the control IC to malfunction and lead to system deterioration or damage. To prevent such malfunction, the undervoltage lockout protection circuit detects decreases in VB voltage and maintains the OUT1-1 terminal and OUT2-1 terminal to “H” level and the OUT1-2 terminal and OUT2-2 terminal to “L” level. The system restores itself when the VB voltage exceeds the threshold voltage of the undervoltage lockout protection circuit.

Table 2 presents a list of functions undervoltage protection circuit (UVLO) operation. *

Looking for pricing, stock, or lifecycle information?

Click below to explore more details on WIN SOURCE:

- [View MB39C011APFT-G-BND-ERE1 on WIN SOURCE](#)
- [Fujitsu Electronics America, Inc. Information](#)

Optimize Your Supply Chain with WIN SOURCE Solutions

- ✓ Global Sourcing Solution
- ✓ Obsolete Management
- ✓ Cost Control Management
- ✓ Shortage Management
- ✓ Alternative Solution
- ✓ Excess Inventory Management