



**THE DATASHEET OF
MC100EL91DWR2G**



MC100EL91

5 V Triple PECL Input to -5 V ECL Output Translator

Description

The MC100EL91 is a triple PECL input to ECL output translator. The device receives standard voltage differential PECL signals, determined by the V_{CC} supply level, and translates them to differential -5 V ECL output signals. (For translation of LVPECL to -3.3 V ECL output, see MC100LVEL91.)

To accomplish the level translation, the EL91 requires three power rails. The V_{CC} supply should be connected to the positive supply, and the V_{EE} pin should be connected to the negative power supply. The GND pins are connected to the system ground plane. Both V_{EE} and V_{CC} should be bypassed to ground via 0.01 μF capacitors.

Under open input conditions, the \bar{D} input will be biased at $V_{CC}/2$ and the D input will be pulled to GND. This condition will force the Q output to a low, ensuring stability.

The V_{BB} pin, an internally generated voltage supply, is available to this device only. For single-ended input conditions, the unused differential input is connected to V_{BB} as a switching reference voltage. V_{BB} may also rebias AC coupled inputs. When used, decouple V_{BB} and V_{CC} via a 0.01 μF capacitor and limit current sourcing or sinking to 0.5 mA. When not used, V_{BB} should be left open.

Features

- 670 ps Typical Propagation Delay
- ESD Protection: > 2 kV Human Body Model
- The 100 Series Contains Temperature Compensation
- Operating Range:
 - ◆ $V_{CC} = 4.75 \text{ V to } 5.5 \text{ V}$
 - ◆ $V_{EE} = -4.2 \text{ V to } -5.5 \text{ V}$; GND = 0 V
- Internal Input Pulldown Resistors
- Q Output will Default LOW with Inputs Open or at GND
- Meets or Exceeds JEDEC Spec EIA/JESD78 IC Latchup Test
- Moisture Sensitivity Level: 3 (Pb-Free)
 - ◆ For Additional Information, see Application Note [AND8003/D](#)
- Flammability Rating: UL 94 V-0 @ 0.125 in, Oxygen Index: 28 to 34
- Transistor Count = 282 devices
- These Devices are Pb-Free, Halogen Free and are RoHS Compliant



ON Semiconductor®

www.onsemi.com

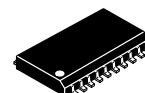

SOIC-20 WB
DW SUFFIX
CASE 751D-05

MARKING DIAGRAM*

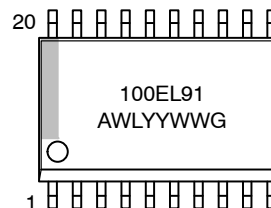

A = Assembly Location
WL = Wafer Lot
YY = Year
WW = Work Week
G = Pb-Free Package

*For additional marking information, refer to Application Note [AND8002/D](#).

ORDERING INFORMATION

Device	Package	Shipping†
MC100EL91DWG	SOIC-20 WB (Pb-Free)	38 Units/Tube
MC100EL91DWR2G	SOIC-20 WB (Pb-Free)	1000/Tape & Reel

†For information on tape and reel specifications, including part orientation and tape sizes, please refer to our Tape and Reel Packaging Specifications Brochure, [BRD8011/D](#).

MC100EL91

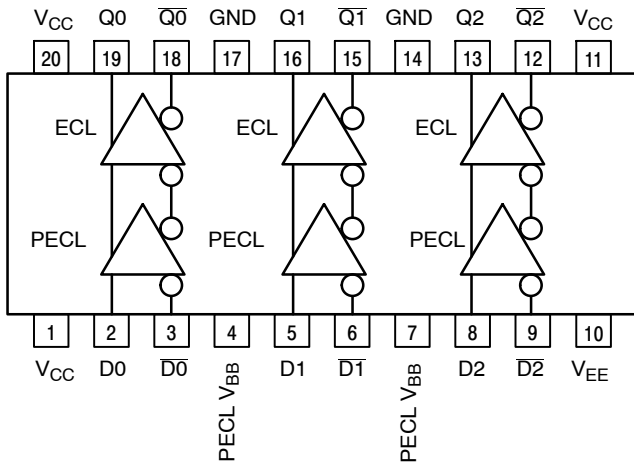

Table 1. PIN DESCRIPTION

PIN	FUNCTION
Dn, \overline{Dn}	PECL Inputs
Qn, \overline{Qn}	ECL Outputs
PECL V_{BB}	PECL Reference Voltage Output
V_{CC}	Positive Supply
V_{EE}	Negative Supply
GND	Ground

**All V_{CC} pins are tied together on the die.

Warning: All V_{CC} , V_{EE} , and GND pins must be externally connected to Power Supply to guarantee proper operation.

Figure 1. 20-Lead Pinout (Top View) and Logic Diagram

Table 2. MAXIMUM RATINGS

Symbol	Parameter	Condition 1	Condition 2	Rating	Unit
V_{CC}	PECL Power Supply	GND = 0 V		8 to 0	V
V_{EE}	NECL Power Supply	GND = 0 V		-8 to 0	V
V_I	PECL Input Voltage	GND = 0 V	$V_I \leq V_{CC}$	6 to 0	V
I_{out}	Output Current	Continuous Surge		50 100	mA
I_{BB}	PECL V_{BB} Sink/Source			± 0.5	mA
T_A	Operating Temperature Range			-40 to +85	$^{\circ}\text{C}$
T_{stg}	Storage Temperature Range			-65 to +150	$^{\circ}\text{C}$
θ_{JA}	Thermal Resistance (Junction-to-Ambient)	0 lfpm 500 lfpm	SOIC-20 WB	90 60	$^{\circ}\text{C}/\text{W}$
θ_{JC}	Thermal Resistance (Junction-to-Case)	Standard Board	SOIC-20 WB	30 to 35	$^{\circ}\text{C}/\text{W}$
T_{sol}	Wave Solder (Pb-Free)	<2 to 3 sec @ 248 $^{\circ}\text{C}$		265	$^{\circ}\text{C}$

Stresses exceeding those listed in the Maximum Ratings table may damage the device. If any of these limits are exceeded, device functionality should not be assumed, damage may occur and reliability may be affected.

MC100EL91

Table 3. PECL INPUT DC CHARACTERISTICS ($V_{CC} = 5.0\text{ V}$; $V_{EE} = -5.0\text{ V}$; $GND = 0\text{ V}$ (Note 1))

Symbol	Characteristic	-40°C			25°C			85°C			Unit
		Min	Typ	Max	Min	Typ	Max	Min	Typ	Max	
I_{CC}	V_{CC} Power Supply Current			11		6	11			11	mA
V_{IH}	Input HIGH Voltage (Single-Ended)	3835		4120	3835		4120	3835		4120	mV
V_{IL}	Input LOW Voltage (Single-Ended)	3190		3525	3190		3525	3190		3525	mV
PECL V_{BB}	Output Voltage Reference	3.62		3.74	3.62		3.74	3.62		3.74	V
V_{IHCMR}	Input HIGH Voltage Common Mode Range (Differential) (Note 2) $V_{PP} < 500\text{ mV}$ $V_{PP} \geq 500\text{ mV}$	1.3 1.5		4.8 4.8	1.2 1.4		4.8 4.8	1.2 1.4		4.8 4.8	V
I_{IH}	Input HIGH Current			150			150			150	μA
I_{IL}	Input LOW Current	0.5			0.5			0.5			μA

NOTE: Device will meet the specifications after thermal equilibrium has been established when mounted in a test socket or printed circuit board with maintained transverse airflow greater than 500 lfm. Electrical parameters are guaranteed only over the declared operating temperature range. Functional operation of the device exceeding these conditions is not implied. Device specification limit values are applied individually under normal operating conditions and not valid simultaneously.

1. Input parameters vary 1:1 with V_{CC} . $V_{CC} = +4.75\text{ V}$ to $+5.2\text{ V}$, $V_{EE} = -4.20\text{ V}$ to -5.5 V .
2. V_{IHCMR} min varies 1:1 with GND . V_{IHCMR} max varies 1:1 with V_{CC} .

Table 4. NECL OUTPUT DC CHARACTERISTICS ($V_{CC} = 5.0\text{ V}$ to 5.0 V ; $V_{EE} = -5.0\text{ V}$; $GND = 0\text{ V}$ (Note 1))

Symbol	Characteristic	-40°C			25°C			85°C			Unit
		Min	Typ	Max	Min	Typ	Max	Min	Typ	Max	
I_{EE}	V_{EE} Power Supply Current			28		22	28			30	mA
V_{OH}	Output HIGH Voltage (Note 2)	-1085	-1005	-880	-1025	-955	-880	-1025	-955	-880	mV
V_{OL}	Output LOW Voltage (Note 2)	-1830	-1695	-1555	-1810	-1705	-1620	-1810	-1705	-1620	mV

NOTE: Device will meet the specifications after thermal equilibrium has been established when mounted in a test socket or printed circuit board with maintained transverse airflow greater than 500 lfm. Electrical parameters are guaranteed only over the declared operating temperature range. Functional operation of the device exceeding these conditions is not implied. Device specification limit values are applied individually under normal operating conditions and not valid simultaneously.

1. Output parameters vary 1:1 with GND . $V_{CC} = +4.75\text{ V}$ to $+5.2\text{ V}$, $V_{EE} = -4.20\text{ V}$ to -5.5 V .
2. Outputs are terminated through a $50\ \Omega$ resistor to $GND - 2.0\text{ V}$

MC100EL91

Table 5. AC CHARACTERISTICS ($V_{CC} = 5.0\text{ V}$; $V_{EE} = -5.0\text{ V}$; $GND = 0\text{ V}$ (Note 4))

Symbol	Characteristic	-40°C			25°C			85°C			Unit
		Min	Typ	Max	Min	Typ	Max	Min	Typ	Max	
f_{max}	Maximum Toggle Frequency		700			700			700		MHz
t_{PLH} t_{PHL}	Propagation Delay D to Q Differential Single-Ended.	540 490	640 640	740 790	570 520	670 670	770 820	610 560	710 710	810 860	ps
t_{SKEW}	Skew Output-to-Output (Note 1) Part-to-Part (Differential) (Note 1) Cycle (Differential) (Note 2)		40 25	100 200		40 25	100 200		40 25	100 200	ps
t_{JITTER}	Random Clock Jitter @ 700 MHz		1.2			1.2			1.2		pS(RMS)
V_{PP}	Input Swing (Note 3)	200		1000	200		1000	200		1000	mV
t_r t_f	Output Rise/Fall Times Q (20% - 80%)	270	400	530	270	400	530	270	400	530	ps

NOTE: Device will meet the specifications after thermal equilibrium has been established when mounted in a test socket or printed circuit board with maintained transverse airflow greater than 500 lpm. Electrical parameters are guaranteed only over the declared operating temperature range. Functional operation of the device exceeding these conditions is not implied. Device specification limit values are applied individually under normal operating conditions and not valid simultaneously.

1. Skews are valid across specified voltage range, part-to-part skew is for a given temperature.
2. Duty cycle skew is the difference between a t_{PLH} and t_{PHL} propagation delay through a device.
3. $V_{PP}(\text{min})$ is the minimum input swing for which AC parameters are guaranteed. The device has a DC gain of ≈ 40 .
4. $V_{CC} = +4.75\text{ V}$ to $+5.2\text{ V}$, $V_{EE} = -4.20\text{ V}$ to -5.5 V . Outputs are terminated through a $50\ \Omega$ resistor to $GND - 2.0\text{ V}$.

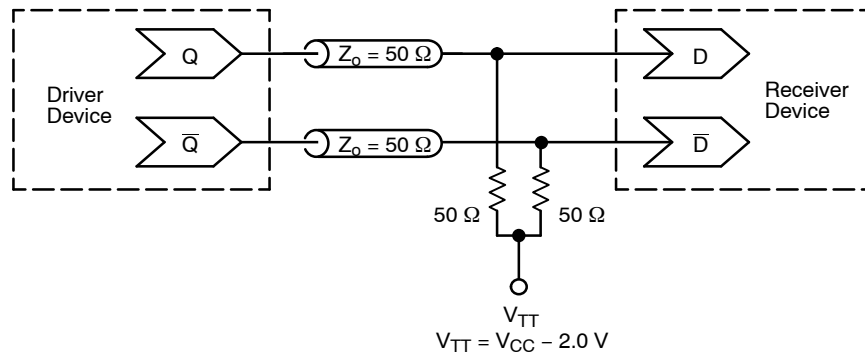

Figure 2. Typical Termination for Output Driver and Device Evaluation
(See Application Note [AND8020/D](#) – Termination of ECL Logic Devices.)

Resource Reference of Application Notes

- AN1405/D** – ECL Clock Distribution Techniques
- AN1406/D** – Designing with PECL (ECL at +5.0 V)
- AN1503/D** – ECLinPS™ I/O SPICE Modeling Kit
- AN1504/D** – Metastability and the ECLinPS Family
- AN1568/D** – Interfacing Between LVDS and ECL
- AN1672/D** – The ECL Translator Guide
- AND8001/D** – Odd Number Counters Design
- AND8002/D** – Marking and Date Codes
- AND8020/D** – Termination of ECL Logic Devices
- AND8066/D** – Interfacing with ECLinPS
- AND8090/D** – AC Characteristics of ECL Devices

MC100EL91

PACKAGE DIMENSIONS

SOIC-20 WB
CASE 751D-05
ISSUE H

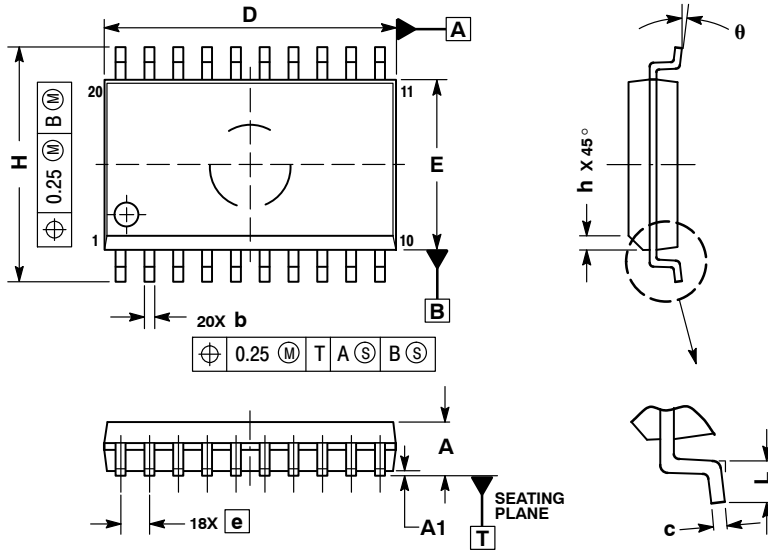

NOTES:

1. DIMENSIONS ARE IN MILLIMETERS.
2. INTERPRET DIMENSIONS AND TOLERANCES PER ASME Y14.5M, 1994.
3. DIMENSIONS D AND E DO NOT INCLUDE MOLD PROTRUSION.
4. MAXIMUM MOLD PROTRUSION 0.15 PER SIDE.
5. DIMENSION B DOES NOT INCLUDE DAMBAR PROTRUSION. ALLOWABLE PROTRUSION SHALL BE 0.13 TOTAL IN EXCESS OF B DIMENSION AT MAXIMUM MATERIAL CONDITION.

MILLIMETERS		
DIM	MIN	MAX
A	2.35	2.65
A1	0.10	0.25
b	0.35	0.49
c	0.23	0.32
D	12.65	12.95
E	7.40	7.60
e	1.27 BSC	
H	10.05	10.55
h	0.25	0.75
L	0.50	0.90
theta	0°	7°

RECOMMENDED SOLDERING FOOTPRINT*

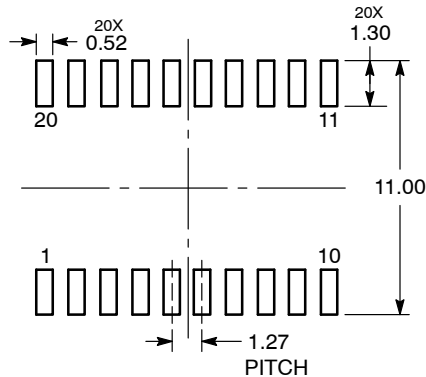

DIMENSIONS: MILLIMETERS

*For additional information on our Pb-Free strategy and soldering details, please download the ON Semiconductor Soldering and Mounting Techniques Reference Manual, [SOLDERRM/D](#).

ECLinPS is a registered trademark of Semiconductor Components Industries, LLC (SCILLC) or its subsidiaries in the United States and/or other countries.

ON Semiconductor and are trademarks of Semiconductor Components Industries, LLC dba ON Semiconductor or its subsidiaries in the United States and/or other countries. ON Semiconductor owns the rights to a number of patents, trademarks, copyrights, trade secrets, and other intellectual property. A listing of ON Semiconductor's product/patent coverage may be accessed at www.onsemi.com/site/pdf/Patent-Marking.pdf. ON Semiconductor reserves the right to make changes without further notice to any products herein. ON Semiconductor makes no warranty, representation or guarantee regarding the suitability of its products for any particular purpose, nor does ON Semiconductor assume any liability arising out of the application or use of any product or circuit, and specifically disclaims any and all liability, including without limitation special, consequential or incidental damages. Buyer is responsible for its products and applications using ON Semiconductor products, including compliance with all laws, regulations and safety requirements or standards, regardless of any support or applications information provided by ON Semiconductor. "Typical" parameters which may be provided in ON Semiconductor data sheets and/or specifications can and do vary in different applications and actual performance may vary over time. All operating parameters, including "Typicals" must be validated for each customer application by customer's technical experts. ON Semiconductor does not convey any license under its patent rights nor the rights of others. ON Semiconductor products are not designed, intended, or authorized for use as a critical component in life support systems or any FDA Class 3 medical devices or medical devices with a same or similar classification in a foreign jurisdiction or any devices intended for implantation in the human body. Should Buyer purchase or use ON Semiconductor products for any such unintended or unauthorized application, Buyer shall indemnify and hold ON Semiconductor and its officers, employees, subsidiaries, affiliates, and distributors harmless against all claims, costs, damages, and expenses, and reasonable attorney fees arising out of, directly or indirectly, any claim of personal injury or death associated with such unintended or unauthorized use, even if such claim alleges that ON Semiconductor was negligent regarding the design or manufacture of the part. ON Semiconductor is an Equal Opportunity/Affirmative Action Employer. This literature is subject to all applicable copyright laws and is not for resale in any manner.

PUBLICATION ORDERING INFORMATION

LITERATURE FULFILLMENT:

Literature Distribution Center for ON Semiconductor
19521 E. 32nd Pkwy, Aurora, Colorado 80011 USA
Phone: 303-675-2175 or 800-344-3860 Toll Free USA/Canada
Fax: 303-675-2176 or 800-344-3867 Toll Free USA/Canada
Email: orderlit@onsemi.com

N. American Technical Support: 800-282-9855 Toll Free
USA/Canada
Europe, Middle East and Africa Technical Support:
Phone: 421 33 790 2910
Japan Customer Focus Center
Phone: 81-3-5817-1050

ON Semiconductor Website: www.onsemi.com
Order Literature: <http://www.onsemi.com/orderlit>

For additional information, please contact your local Sales Representative

Looking for pricing, stock, or lifecycle information?

Click below to explore more details on WIN SOURCE:

 [View MC100EL91DWR2G on WIN SOURCE](#)

 [ON Semiconductor](#) Information

Optimize Your Supply Chain with WIN SOURCE Solutions

-  Global Sourcing Solution
-  Obsolete Management
-  Cost Control Management
-  Shortage Management
-  Alternative Solution
-  Excess Inventory Management