



**THE DATASHEET OF
MC100EP139DWR2G**



MC10EP139, MC100EP139

3.3 V / 5 V ECL $\div 2/4$, $\div 4/5/6$ Clock Generation Chip

Description

The MC10/100EP139 is a low skew $\div 2/4$, $\div 4/5/6$ clock generation chip designed explicitly for low skew clock generation applications. The internal dividers are synchronous to each other, therefore, the common output edges are all precisely aligned.

The common enable (\overline{EN}) is synchronous so that the internal dividers will only be enabled/disabled when the internal clock is already in the LOW state. This avoids any chance of generating a runt clock pulse on the internal clock when the device is enabled/disabled as can happen with an asynchronous control. The internal enable flip-flop is clocked on the falling edge of the input clock, therefore, all associated specification limits are referenced to the negative edge of the clock input.

Upon start-up, the internal flip-flops will attain a random state; therefore the master reset (MR) input may require assertion to ensure system synchronization. Internal divider design ensures synchronization between the $\div 2/4$ and the $\div 4/5/6$ outputs within a device. All V_{CC} and V_{EE} pins must be externally connected to power supply to guarantee proper operation.

The V_{BB} Pin, an internally generated voltage supply, is available to this device only. For Single-Ended input conditions, the unused differential input is connected to V_{BB} as a switching reference voltage. V_{BB} may also rebias AC coupled inputs. When used, decouple V_{BB} and V_{CC} via a 0.01 μF capacitor and limit current sourcing or sinking to 0.5 mA. When not used, V_{BB} should be left open.

The 100 Series contains temperature compensation.

Features

- Maximum Frequency = > 1.0 GHz Typical
- 50 ps Output-to-Output Skew
- PECL Mode Operating Range:
 $V_{CC} = 3.0 \text{ V to } 5.5 \text{ V}$ with $V_{EE} = 0 \text{ V}$
- NECL Mode Operating Range:
 $V_{CC} = 0 \text{ V}$ with $V_{EE} = -3.0 \text{ V to } -5.5 \text{ V}$
- Open Input Default State
- Safety Clamp on Inputs
- Synchronous Enable/Disable
- Master Reset for Synchronization of Multiple Chips
- V_{BB} Output
- These Devices are Pb-Free, Halogen Free and are RoHS Compliant



ON Semiconductor®

www.onsemi.com

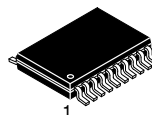

TSSOP-20 WB
DT SUFFIX
CASE 948E

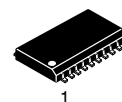

SOIC-20 WB
DW SUFFIX
CASE 751D



QFN-20
MN SUFFIX
CASE 485E

MARKING DIAGRAMS*

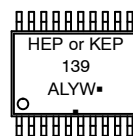

TSSOP-20 WB

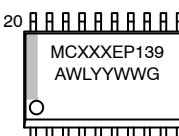

SOIC-20 WB

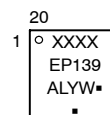

QFN-20

HEP = MC10EP
KEP = MC100EP
XXX = 10 or 100
A = Assembly Location
L,WL = Wafer Lot
Y, YY = Year
W, WW = Work Week
G or ■ = Pb-Free Package

(Note: Microdot may be in either location)

*For additional marking information, refer to Application Note [AND8002/D](#).

ORDERING INFORMATION

See detailed ordering and shipping information in the package dimensions section on page 11 of this data sheet.

MC10EP139, MC100EP139

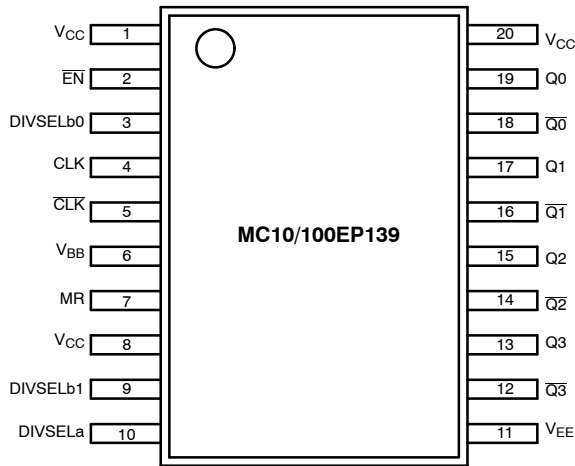

Warning: All V_{CC} and V_{EE} pins must be externally connected to a Power Supply to guarantee proper operation.

Figure 1. 20-Lead Pinout (Top View)

Table 1. PIN DESCRIPTION

| PIN | FUNCTION |
|---|------------------------------------|
| CLK*, \overline{CLK} * | ECL Differential Clock Inputs |
| EN* | ECL Sync Enable |
| MR* | ECL Master Reset |
| V_{BB} | ECL Reference Output |
| Q0, Q1, $\overline{Q0}$, $\overline{Q1}$ | ECL Differential ÷ 2/4 Outputs |
| Q2, Q3, $\overline{Q2}$, $\overline{Q3}$ | ECL Differential ÷ 4/5/6 Outputs |
| DIVSELa* | ECL Frequency Select Input ÷ 2/4 |
| DIVSELb0* | ECL Frequency Select Input ÷ 4/5/6 |
| DIVSELb1* | ECL Frequency Select Input ÷ 4/5/6 |
| V_{CC} | ECL Positive Supply |
| V_{EE} | ECL Negative Supply |
| EP | Exposed Pad |

*Pins will default low when left open.

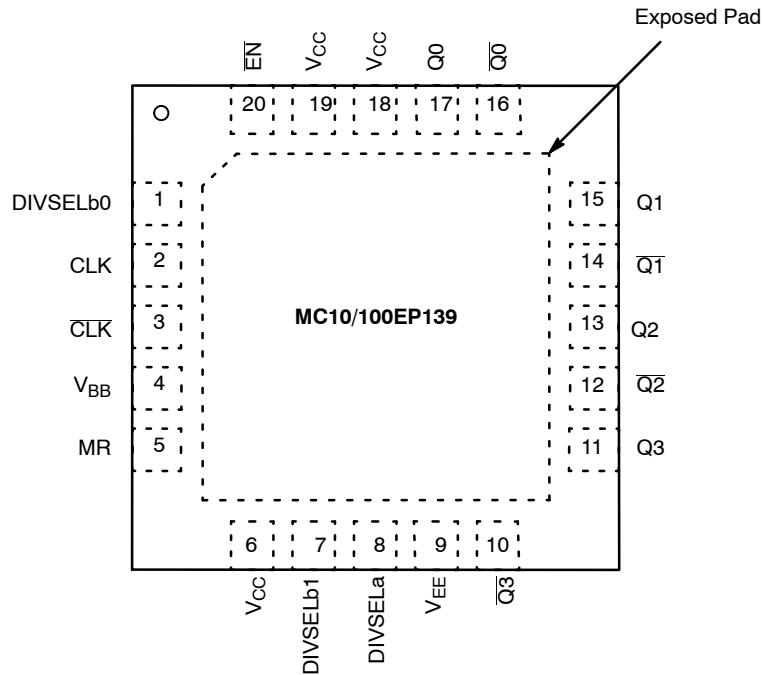

Warning: All V_{CC} and V_{EE} pins must be externally connected to a Power Supply to guarantee proper operation.
The Exposed Pad (EP) on package bottom must be attached to a heat-sinking conduit. The Exposed Pad may only be electrically connected to V_{EE} .

Figure 2. QFN-20 Pinout (Top View)

MC10EP139, MC100EP139

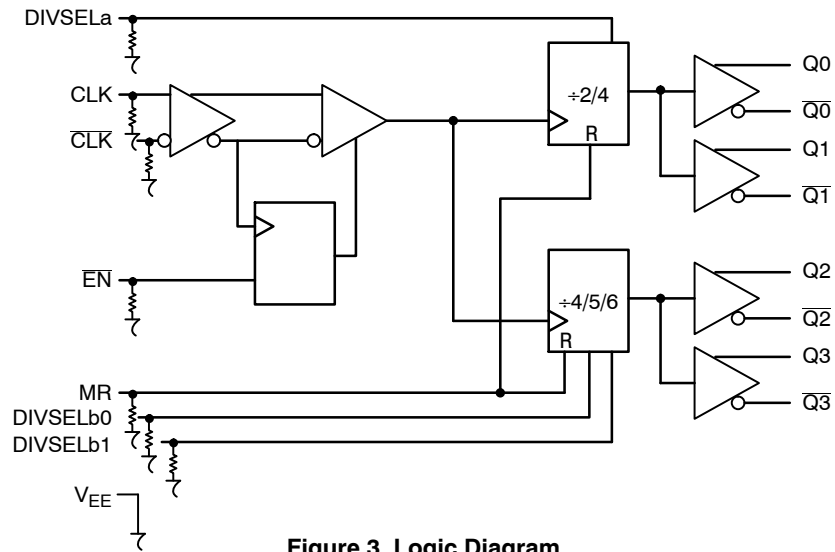

Figure 3. Logic Diagram

Table 2. FUNCTION TABLES

| CLK | EN | MR | Function |
|-----|----|----|------------|
| Z | L | L | Divide |
| ZZ | H | L | Hold Q0:3 |
| X | X | H | Reset Q0:3 |

Z = Low-to-High Transition
ZZ = High-to-Low Transition

| DIVSELa | Q0:1 Outputs | |
|----------|--------------|--------------|
| L | Divide by 2 | |
| H | Divide by 4 | |
| DIVSELb0 | DIVSELb1 | Q2:3 Outputs |
| L | L | Divide by 4 |
| H | L | Divide by 6 |
| L | H | Divide by 5 |
| H | H | Divide by 5 |

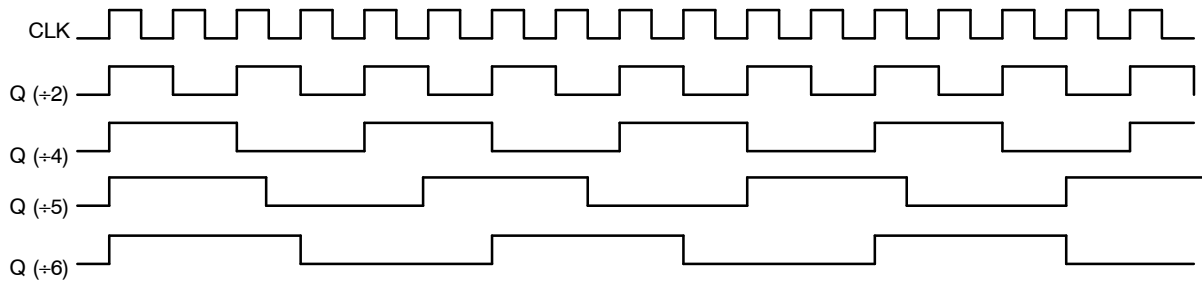

Figure 4. CLK and OUTPUT Timing Diagram

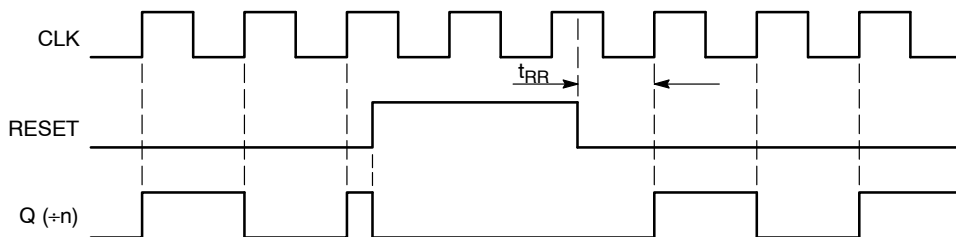

Figure 5. Timing Diagram

MC10EP139, MC100EP139

Table 3. ATTRIBUTES

| Characteristics | Value |
|---|-------------------------------|
| Internal Input Pulldown Resistor | 75 kΩ |
| Internal Input Pullup Resistor | N/A |
| ESD Protection Human Body Model Machine Model Charged Device Model | > 2 kV > 100 V > 2 kV |
| Moisture Sensitivity, Indefinite Time Out of Drypack (Note 1) | Pb-Free Pkg |
| SOIC–20 WB TSSOP–20 WB QFN–20 | Level 3 Level 1 Level 1 |
| Flammability Rating Oxygen Index: 28 to 34 | UL 94 V–0 @ 0.125 in |
| Transistor Count | 758 Devices |
| Meets or exceeds JEDEC Spec EIA/JESD78 IC Latchup Test | |

1. For additional information, see Application Note [AND8003/D](#).

Table 4. MAXIMUM RATINGS

| Symbol | Parameter | Condition 1 | Condition 2 | Rating | Unit |
|------------------|--|--|--|-------------|------|
| V _{CC} | PECL Mode Power Supply | V _{EE} = 0 V | | 6 | V |
| V _{EE} | NECL Mode Power Supply | V _{CC} = 0 V | | –6 | V |
| V _I | PECL Mode Input Voltage NECL Mode Input Voltage | V _{EE} = 0 V V _{CC} = 0 V | V _I ≤ V _{CC} V _I ≥ V _{EE} | 6 –6 | V |
| I _{out} | Output Current | Continuous Surge | | 50 100 | mA |
| I _{BB} | V _{BB} Sink/Source | | | ±0.5 | mA |
| T _A | Operating Temperature Range | | | –40 to +85 | °C |
| T _{stg} | Storage Temperature Range | | | –65 to +150 | °C |
| θ _{JA} | Thermal Resistance (Junction-to-Ambient) | 0 lfpm 500 lfpm | TSSOP–20 WB TSSOP–20 WB | 140 100 | °C/W |
| θ _{JC} | Thermal Resistance (Junction-to-Case) | Standard Board | TSSOP–20 WB | 23 to 41 | °C/W |
| θ _{JA} | Thermal Resistance (Junction-to-Ambient) | 0 lfpm 500 lfpm | SOIC–20 WB SOIC–20 WB | 90 60 | °C/W |
| θ _{JC} | Thermal Resistance (Junction-to-Case) | Standard Board | SOIC–20 WB | 33 to 35 | °C/W |
| θ _{JA} | Thermal Resistance (Junction-to-Ambient) | 0 lfpm 500 lfpm | QFN–20 QFN–20 | 47 33 | °C/W |
| θ _{JC} | Thermal Resistance (Junction-to-Case) | Standard Board | QFN–20 | 18 | °C/W |
| T _{sol} | Wave Solder (Pb-Free) | < 2 to 3 sec @ 260°C | | 265 | °C |

Stresses exceeding those listed in the Maximum Ratings table may damage the device. If any of these limits are exceeded, device functionality should not be assumed, damage may occur and reliability may be affected.

MC10EP139, MC100EP139

Table 5. 10EP DC CHARACTERISTICS, PECL ($V_{CC} = 3.3\text{ V}$, $V_{EE} = 0\text{ V}$ (Note 1))

| Symbol | Characteristic | -40°C | | | 25°C | | | 85°C | | | Unit |
|-------------|--|-------|------|------|------|------|------|------|------|------|---------------|
| | | Min | Typ | Max | Min | Typ | Max | Min | Typ | Max | |
| I_{EE} | Power Supply Current | 65 | 82 | 105 | 65 | 83 | 105 | 65 | 84 | 105 | mA |
| V_{OH} | Output HIGH Voltage (Note 2) | 2165 | 2290 | 2415 | 2230 | 2355 | 2480 | 2290 | 2415 | 2540 | mV |
| V_{OL} | Output LOW Voltage (Note 2) | 1365 | 1490 | 1615 | 1430 | 1555 | 1680 | 1490 | 1615 | 1740 | mV |
| V_{IH} | Input HIGH Voltage (Single-Ended) | 2090 | | 2415 | 2155 | | 2480 | 2215 | | 2540 | mV |
| V_{IL} | Input LOW Voltage (Single-Ended) | 1365 | | 1690 | 1460 | | 1755 | 1490 | | 1815 | mV |
| V_{BB} | Output Voltage Reference | 1790 | 1890 | 1990 | 1855 | 1955 | 2055 | 1915 | 2015 | 2115 | mV |
| V_{IHCMR} | Input HIGH Voltage Common Mode Range (Differential Configuration) (Note 3) | 2.0 | | 3.3 | 2.0 | | 3.3 | 2.0 | | 3.3 | V |
| I_{IH} | Input HIGH Current | | | 150 | | | 150 | | | 150 | μA |
| I_{IL} | Input LOW Current | 0.5 | | | 0.5 | | | 0.5 | | | μA |

NOTE: Device will meet the specifications after thermal equilibrium has been established when mounted in a test socket or printed circuit board with maintained transverse airflow greater than 500 lpm. Electrical parameters are guaranteed only over the declared operating temperature range. Functional operation of the device exceeding these conditions is not implied. Device specification limit values are applied individually under normal operating conditions and not valid simultaneously.

1. Input and output parameters vary 1:1 with V_{CC} . V_{EE} can vary +0.3 V to -2.2 V.
2. All loading with 50 Ω to $V_{CC} - 2.0\text{ V}$ (see Figure 10).
3. V_{IHCMR} min varies 1:1 with V_{EE} , V_{IHCMR} max varies 1:1 with V_{CC} . The V_{IHCMR} range is referenced to the most positive side of the differential input signal.

Table 6. 10EP DC CHARACTERISTICS, PECL ($V_{CC} = 5.0\text{ V}$, $V_{EE} = 0\text{ V}$ (Note 1))

| Symbol | Characteristic | -40°C | | | 25°C | | | 85°C | | | Unit |
|-------------|--|-------|------|------|------|------|------|------|------|------|---------------|
| | | Min | Typ | Max | Min | Typ | Max | Min | Typ | Max | |
| I_{EE} | Power Supply Current | 65 | 82 | 105 | 65 | 83 | 105 | 65 | 84 | 105 | mA |
| V_{OH} | Output HIGH Voltage (Note 2) | 3865 | 3990 | 4115 | 3930 | 4055 | 4180 | 3990 | 4115 | 4240 | mV |
| V_{OL} | Output LOW Voltage (Note 2) | 3065 | 3190 | 3315 | 3130 | 3255 | 3380 | 3190 | 3315 | 3440 | mV |
| V_{IH} | Input HIGH Voltage (Single-Ended) | 3790 | | 4115 | 3855 | | 4180 | 3915 | | 4240 | mV |
| V_{IL} | Input LOW Voltage (Single-Ended) | 3065 | | 3390 | 3130 | | 3455 | 3190 | | 3515 | mV |
| V_{BB} | Output Voltage Reference | 3490 | 3590 | 3690 | 3555 | 3655 | 3755 | 3615 | 3715 | 3815 | mV |
| V_{IHCMR} | Input HIGH Voltage Common Mode Range (Differential Configuration) (Note 3) | 2.0 | | 5.0 | 2.0 | | 5.0 | 2.0 | | 5.0 | V |
| I_{IH} | Input HIGH Current | | | 150 | | | 150 | | | 150 | μA |
| I_{IL} | Input LOW Current | 0.5 | | | 0.5 | | | 0.5 | | | μA |

NOTE: Device will meet the specifications after thermal equilibrium has been established when mounted in a test socket or printed circuit board with maintained transverse airflow greater than 500 lpm. Electrical parameters are guaranteed only over the declared operating temperature range. Functional operation of the device exceeding these conditions is not implied. Device specification limit values are applied individually under normal operating conditions and not valid simultaneously.

1. Input and output parameters vary 1:1 with V_{CC} . V_{EE} can vary +2.0 V to -0.5 V.
2. All loading with 50 Ω to $V_{CC} - 2.0\text{ V}$ (see Figure 10).
3. V_{IHCMR} min varies 1:1 with V_{EE} , V_{IHCMR} max varies 1:1 with V_{CC} . The V_{IHCMR} range is referenced to the most positive side of the differential input signal.

MC10EP139, MC100EP139

Table 7. 10EP DC CHARACTERISTICS, NECL ($V_{CC} = 0\text{ V}$, $V_{EE} = -5.5\text{ V}$ to -3.0 V (Note 1))

| Symbol | Characteristic | -40°C | | | 25°C | | | 85°C | | | Unit |
|-------------|--|--------------|-------|-------|--------------|-------|-------|--------------|-------|-------|---------------|
| | | Min | Typ | Max | Min | Typ | Max | Min | Typ | Max | |
| I_{EE} | Power Supply Current | 65 | 82 | 105 | 65 | 83 | 105 | 65 | 84 | 105 | mA |
| V_{OH} | Output HIGH Voltage (Note 2) | -1135 | -1010 | -885 | -1070 | -945 | -820 | -1010 | -885 | -760 | mV |
| V_{OL} | Output LOW Voltage (Note 2) | -1935 | -1810 | -1685 | -1870 | -1745 | -1620 | -1810 | -1685 | -1560 | mV |
| V_{IH} | Input HIGH Voltage (Single-Ended) | -1210 | | -885 | -1145 | | -820 | -1085 | | -760 | mV |
| V_{IL} | Input LOW Voltage (Single-Ended) | -1935 | | -1610 | -1870 | | -1545 | -1810 | | -1485 | mV |
| V_{BB} | Output Voltage Reference | -1510 | -1410 | -1310 | -1445 | -1345 | -1245 | -1385 | -1285 | -1185 | mV |
| V_{IHCMR} | Input HIGH Voltage Common Mode Range (Differential Configuration) (Note 3) | $V_{EE}+2.0$ | | 0.0 | $V_{EE}+2.0$ | | 0.0 | $V_{EE}+2.0$ | | 0.0 | V |
| I_{IH} | Input HIGH Current | | | 150 | | | 150 | | | 150 | μA |
| I_{IL} | Input LOW Current | 0.5 | | | 0.5 | | | 0.5 | | | μA |

NOTE: Device will meet the specifications after thermal equilibrium has been established when mounted in a test socket or printed circuit board with maintained transverse airflow greater than 500 lpm. Electrical parameters are guaranteed only over the declared operating temperature range. Functional operation of the device exceeding these conditions is not implied. Device specification limit values are applied individually under normal operating conditions and not valid simultaneously.

1. Input and output parameters vary 1:1 with V_{CC} .
2. All loading with $50\ \Omega$ to $V_{CC} - 2.0\text{ V}$ (see Figure 10).
3. V_{IHCMR} min varies 1:1 with V_{EE} , V_{IHCMR} max varies 1:1 with V_{CC} . The V_{IHCMR} range is referenced to the most positive side of the differential input signal.

Table 8. 100EP DC CHARACTERISTICS, PECL ($V_{CC} = 3.3\text{ V}$, $V_{EE} = 0\text{ V}$ (Note 1))

| Symbol | Characteristic | -40°C | | | 25°C | | | 85°C | | | Unit |
|-------------|--|-------|------|------|------|------|------|------|------|------|---------------|
| | | Min | Typ | Max | Min | Typ | Max | Min | Typ | Max | |
| I_{EE} | Power Supply Current | 70 | 83 | 100 | 70 | 87 | 105 | 75 | 90 | 110 | mA |
| V_{OH} | Output HIGH Voltage (Note 2) | 2155 | 2280 | 2405 | 2155 | 2280 | 2405 | 2155 | 2280 | 2405 | mV |
| V_{OL} | Output LOW Voltage (Note 2) | 1305 | 1480 | 1605 | 1305 | 1480 | 1605 | 1305 | 1480 | 1605 | mV |
| V_{IH} | Input HIGH Voltage (Single-Ended) | 2075 | | 2420 | 2075 | | 2420 | 2075 | | 2420 | mV |
| V_{IL} | Input LOW Voltage (Single-Ended) | 1305 | | 1675 | 1305 | | 1675 | 1305 | | 1675 | mV |
| V_{BB} | Output Voltage Reference | 1725 | 1825 | 1925 | 1725 | 1825 | 1925 | 1725 | 1825 | 1925 | mV |
| V_{IHCMR} | Input HIGH Voltage Common Mode Range (Differential Configuration) (Note 3) | 2.0 | | 3.3 | 2.0 | | 3.3 | 2.0 | | 3.3 | V |
| I_{IH} | Input HIGH Current | | | 150 | | | 150 | | | 150 | μA |
| I_{IL} | Input LOW Current | 0.5 | | | 0.5 | | | 0.5 | | | μA |

NOTE: Device will meet the specifications after thermal equilibrium has been established when mounted in a test socket or printed circuit board with maintained transverse airflow greater than 500 lpm. Electrical parameters are guaranteed only over the declared operating temperature range. Functional operation of the device exceeding these conditions is not implied. Device specification limit values are applied individually under normal operating conditions and not valid simultaneously.

1. Input and output parameters vary 1:1 with V_{CC} . V_{EE} can vary $+0.3\text{ V}$ to -2.2 V .
2. All loading with $50\ \Omega$ to $V_{CC} - 2.0\text{ V}$ (see Figure 10).
3. V_{IHCMR} min varies 1:1 with V_{EE} , V_{IHCMR} max varies 1:1 with V_{CC} . The V_{IHCMR} range is referenced to the most positive side of the differential input signal.

MC10EP139, MC100EP139

Table 9. 100EP DC CHARACTERISTICS, PECL ($V_{CC} = 5.0\text{ V}$, $V_{EE} = 0\text{ V}$ (Note 1))

| Symbol | Characteristic | -40°C | | | 25°C | | | 85°C | | | Unit |
|-------------|--|-------|------|------|------|------|------|------|------|------|---------------|
| | | Min | Typ | Max | Min | Typ | Max | Min | Typ | Max | |
| I_{EE} | Power Supply Current | 70 | 85 | 100 | 70 | 90 | 105 | 75 | 95 | 110 | mA |
| V_{OH} | Output HIGH Voltage (Note 2) | 3855 | 3980 | 4105 | 3855 | 3980 | 4105 | 3855 | 3980 | 4105 | mV |
| V_{OL} | Output LOW Voltage (Note 2) | 3005 | 3180 | 3305 | 3005 | 3180 | 3305 | 3005 | 3180 | 3305 | mV |
| V_{IH} | Input HIGH Voltage (Single-Ended) | 3775 | | 4120 | 3775 | | 4120 | 3775 | | 4120 | mV |
| V_{IL} | Input LOW Voltage (Single-Ended) | 3005 | | 3375 | 3005 | | 3375 | 3005 | | 3375 | mV |
| V_{BB} | Output Voltage Reference | 3425 | 3525 | 3625 | 3425 | 3525 | 3625 | 3425 | 3525 | 3625 | mV |
| V_{IHCMR} | Input HIGH Voltage Common Mode Range (Differential Configuration) (Note 3) | 2.0 | | 5.0 | 2.0 | | 5.0 | 2.0 | | 5.0 | V |
| I_{IH} | Input HIGH Current | | | 150 | | | 150 | | | 150 | μA |
| I_{IL} | Input LOW Current | 0.5 | | | 0.5 | | | 0.5 | | | μA |

NOTE: Device will meet the specifications after thermal equilibrium has been established when mounted in a test socket or printed circuit board with maintained transverse airflow greater than 500 lpm. Electrical parameters are guaranteed only over the declared operating temperature range. Functional operation of the device exceeding these conditions is not implied. Device specification limit values are applied individually under normal operating conditions and not valid simultaneously.

1. Input and output parameters vary 1:1 with V_{CC} . V_{EE} can vary +2.0 V to -0.5 V.
2. All loading with 50 Ω to $V_{CC} - 2.0\text{ V}$ (see Figure 10).
3. V_{IHCMR} min varies 1:1 with V_{EE} . V_{IHCMR} max varies 1:1 with V_{CC} . The V_{IHCMR} range is referenced to the most positive side of the differential input signal.

Table 10. 100EP DC CHARACTERISTICS, NECL ($V_{CC} = 0\text{ V}$, $V_{EE} = -5.5\text{ V}$ to -3.0 V (Note 1))

| Symbol | Characteristic | -40°C | | | 25°C | | | 85°C | | | Unit |
|-------------|--|--------------|-------|-------|--------------|-------|-------|--------------|-------|-------|---------------|
| | | Min | Typ | Max | Min | Typ | Max | Min | Typ | Max | |
| I_{EE} | Power Supply Current | 70 | 85 | 100 | 70 | 90 | 105 | 75 | 95 | 110 | mA |
| V_{OH} | Output HIGH Voltage (Note 2) | -1145 | -1020 | -895 | -1145 | -1020 | -895 | -1145 | -1020 | -895 | mV |
| V_{OL} | Output LOW Voltage (Note 2) | -1995 | -1820 | -1695 | -1995 | -1820 | -1695 | -1995 | -1820 | -1695 | mV |
| V_{IH} | Input HIGH Voltage (Single-Ended) | -1225 | | -880 | -1225 | | -880 | -1225 | | -880 | mV |
| V_{IL} | Input LOW Voltage (Single-Ended) | -1995 | | -1625 | -1995 | | -1625 | -1995 | | -1625 | mV |
| V_{BB} | Output Voltage Reference | -1575 | -1475 | -1375 | -1575 | -1475 | -1375 | -1575 | -1475 | -1375 | mV |
| V_{IHCMR} | Input HIGH Voltage Common Mode Range (Differential Configuration) (Note 3) | $V_{EE}+2.0$ | | 0.0 | $V_{EE}+2.0$ | | 0.0 | $V_{EE}+2.0$ | | 0.0 | V |
| I_{IH} | Input HIGH Current | | | 150 | | | 150 | | | 150 | μA |
| I_{IL} | Input LOW Current | 0.5 | | | 0.5 | | | 0.5 | | | μA |

NOTE: Device will meet the specifications after thermal equilibrium has been established when mounted in a test socket or printed circuit board with maintained transverse airflow greater than 500 lpm. Electrical parameters are guaranteed only over the declared operating temperature range. Functional operation of the device exceeding these conditions is not implied. Device specification limit values are applied individually under normal operating conditions and not valid simultaneously.

1. Input and output parameters vary 1:1 with V_{CC} .
2. All loading with 50 Ω to $V_{CC} - 2.0\text{ V}$ (see Figure 10).
3. V_{IHCMR} min varies 1:1 with V_{EE} . V_{IHCMR} max varies 1:1 with V_{CC} . The V_{IHCMR} range is referenced to the most positive side of the differential input signal.

MC10EP139, MC100EP139

Table 11. AC CHARACTERISTICS ($V_{CC} = 0\text{ V}$; $V_{EE} = -3.0\text{ V}$ to -5.5 V or $V_{CC} = 3.0\text{ V}$ to 5.5 V ; $V_{EE} = 0\text{ V}$ (Note 1))

| Symbol | Characteristic | -40°C | | | 25°C | | | 85°C | | | Unit |
|--------------------------|---|------------|------------|------------|------------|------------|-------------|------------|------------|-------------|------|
| | | Min | Typ | Max | Min | Typ | Max | Min | Typ | Max | |
| f_{max} | Maximum Frequency (See Figures 6, 7, 8 and 9 F_{max} /JITTER) | | > 1 | | | > 1 | | | > 1 | | GHz |
| t_{PLH} , t_{PHL} | Propagation Delay CLK, Q (Diff) MR, Q | 550 700 | 700 800 | 800 900 | 600 700 | 750 850 | 900 1000 | 675 800 | 825 950 | 975 1100 | ps |
| t_{RR} | Reset Recovery | 200 | 100 | | 200 | 100 | | 200 | 100 | | ps |
| t_s | Setup Time EN, CLK DIVSEL, CLK | 200 400 | 120 180 | | 200 400 | 120 180 | | 200 400 | 120 180 | | ps |
| t_h | Hold Time $\overline{\text{CLK}}$, EN CLK, DIVSEL | 100 200 | 50 140 | | 100 200 | 50 140 | | 100 200 | 50 140 | | ps |
| t_{PW} | Minimum Pulse Width MR | 550 | 450 | | 550 | 450 | | 550 | 450 | | ps |
| t_{SKEW} | Within Device Skew Q, \overline{Q} Device-to-Device Skew (Note 2) | | 50 200 | 100 300 | | 50 200 | 100 300 | | 50 200 | 100 300 | ps |
| t_{JITTER} | Random Clock Jitter (RMS) (See Figures 6, 7, 8 and 9 F_{max} /JIT- TER) | | 0.2 | < 1.0 | | 0.2 | < 1.0 | | 0.2 | < 1.5 | ps |
| V_{PP} | Input Voltage Swing (Differential Con- figuration) | 150 | 800 | 1200 | 150 | 800 | 1200 | 150 | 800 | 1200 | mV |
| t_r t_f | Output Rise/Fall Times Q, \overline{Q} (20%–80%) | 110 | 180 | 250 | 125 | 190 | 275 | 150 | 215 | 300 | ps |

NOTE: Device will meet the specifications after thermal equilibrium has been established when mounted in a test socket or printed circuit board with maintained transverse airflow greater than 500 lpm. Electrical parameters are guaranteed only over the declared operating temperature range. Functional operation of the device exceeding these conditions is not implied. Device specification limit values are applied individually under normal operating conditions and not valid simultaneously.

1. Measured using a 750 mV source, 50% duty cycle clock source. All loading with $50\ \Omega$ to $V_{CC} - 2.0\text{ V}$ (see Figure 10).
2. Skew is measured between outputs under identical transitions. Duty cycle skew is defined only for differential operation when the delays are measured from the cross point of the inputs to the cross point of the outputs.

Product parametric performance is indicated in the Electrical Characteristics for the listed test conditions, unless otherwise noted. Product performance may not be indicated by the Electrical Characteristics if operated under different conditions.

MC10EP139, MC100EP139

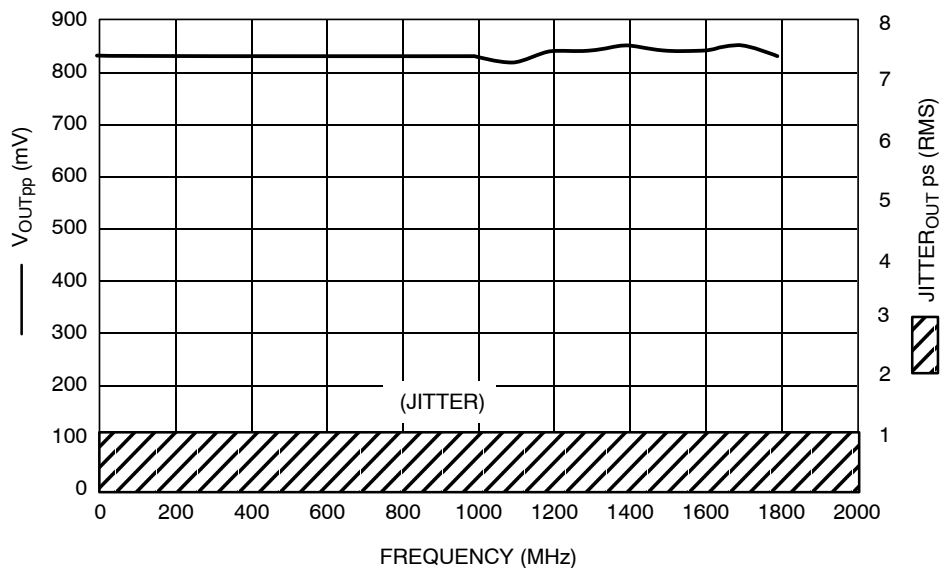

Figure 6. $\div 2$, F_{max}/Jitter

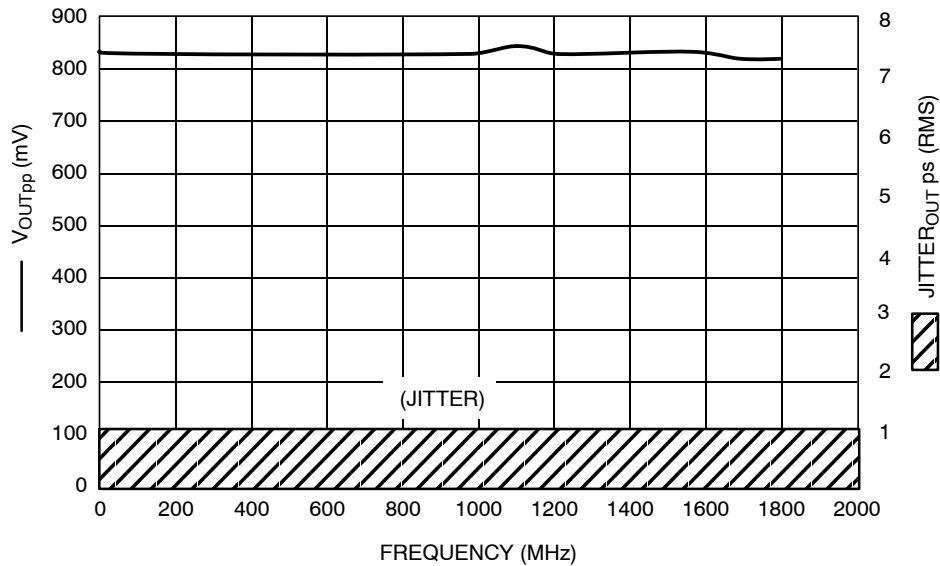

Figure 7. $\div 5$, F_{max}/Jitter

MC10EP139, MC100EP139

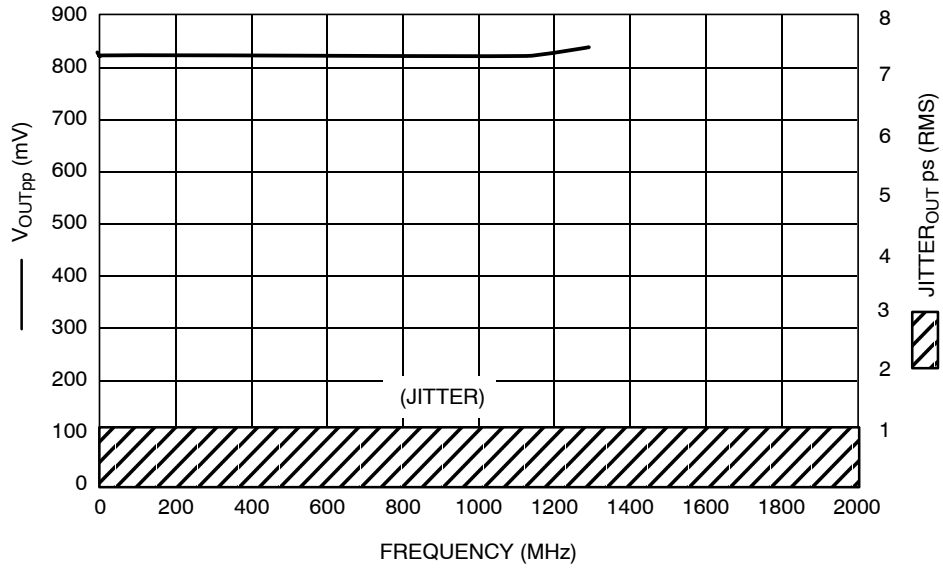

Figure 8. $\div 4, F_{max}/Jitter$

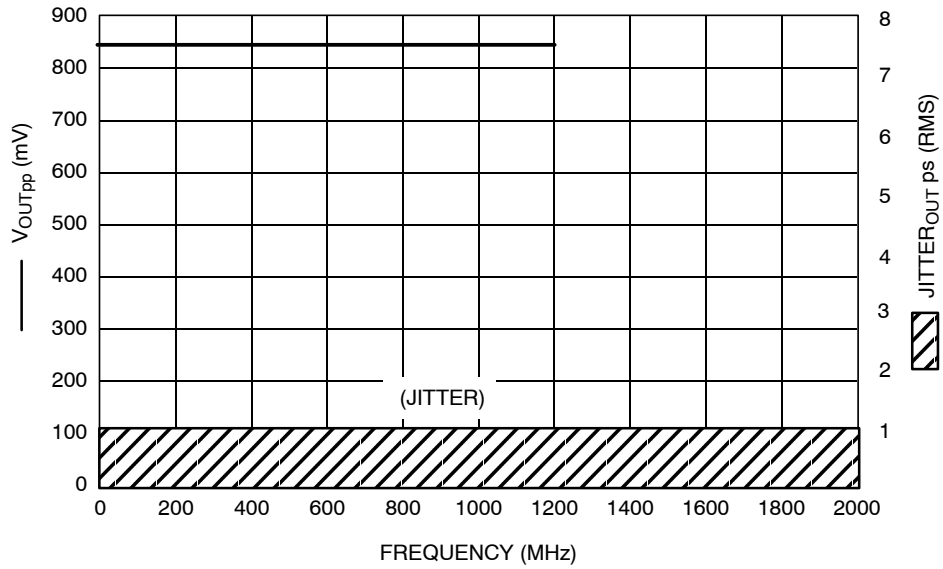

Figure 9. $\div 6, F_{max}/Jitter$

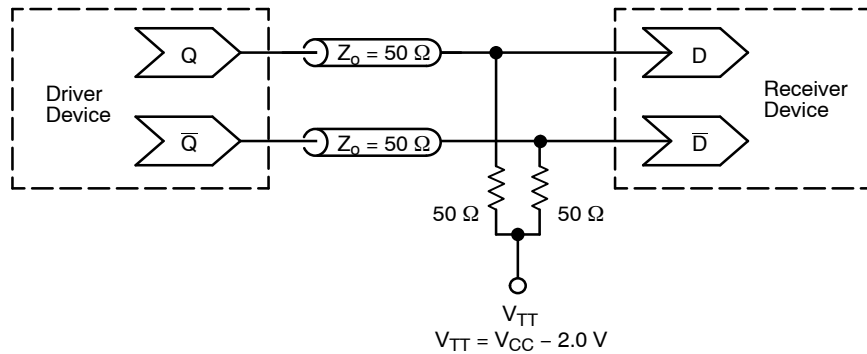

Figure 10. Typical Termination for Output Driver and Device Evaluation
(See Application Note [AND8020/D](#) – Termination of ECL Logic Devices)

MC10EP139, MC100EP139

ORDERING INFORMATION

| Device | Package | Shipping [†] |
|-----------------|--------------------------|-----------------------|
| MC10EP139DTG | TSSOP-20 WB (Pb-Free) | 75 Units / Tube |
| MC10EP139DTR2G | TSSOP-20 WB (Pb-Free) | 2500 / Tape & Reel |
| MC10EP139DWG | SOIC-20 WB (Pb-Free) | 38 Units / Tube |
| MC10EP139DWR2G | SOIC-20 WB (Pb-Free) | 1000 / Tape & Reel |
| MC100EP139DTG | TSSOP-20 WB (Pb-Free) | 75 Units / Tube |
| MC100EP139DTR2G | TSSOP-20 WB (Pb-Free) | 2500 / Tape & Reel |
| MC100EP139DWG | SOIC-20 WB (Pb-Free) | 38 Units / Tube |
| MC100EP139DWR2G | SOIC-20 WB (Pb-Free) | 1000 / Tape & Reel |
| MC100EP139MNG | QFN-20 (Pb-Free) | 92 Units / Tube |
| MC100EP139MNTXG | QFN-20 (Pb-Free) | 3000 / Tape & Reel |

[†]For information on tape and reel specifications, including part orientation and tape sizes, please refer to our Tape and Reel Packaging Specifications Brochure, [BRD8011/D](#).

Resource Reference of Application Notes

- AN1405/D** – ECL Clock Distribution Techniques
- AN1406/D** – Designing with PECL (ECL at +5.0 V)
- AN1503/D** – ECLinPS™ I/O SPICE Modeling Kit
- AN1504/D** – Metastability and the ECLinPS Family
- AN1568/D** – Interfacing Between LVDS and ECL
- AN1672/D** – The ECL Translator Guide
- AND8001/D** – Odd Number Counters Design
- AND8002/D** – Marking and Date Codes
- AND8020/D** – Termination of ECL Logic Devices
- AND8066/D** – Interfacing with ECLinPS
- AND8090/D** – AC Characteristics of ECL Devices

MC10EP139, MC100EP139

PACKAGE DIMENSIONS

TSSOP-20 WB
CASE 948E
ISSUE D

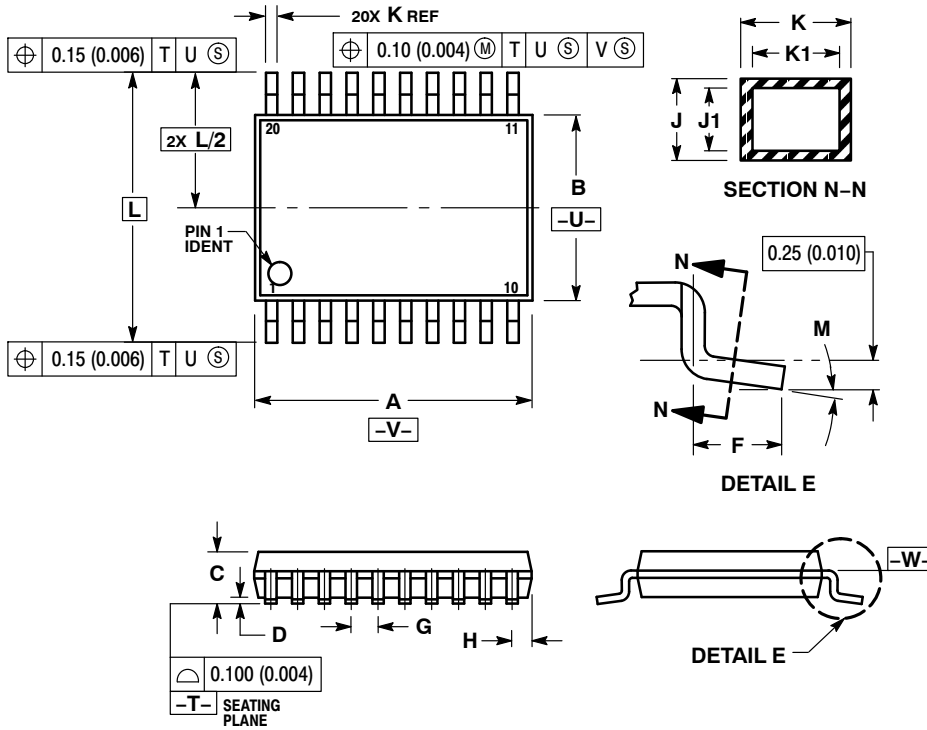

NOTES:

1. DIMENSIONING AND TOLERANCING PER ANSI Y14.5M, 1982.
2. CONTROLLING DIMENSION: MILLIMETER.
3. DIMENSION A DOES NOT INCLUDE MOLD FLASH, PROTRUSIONS OR GATE BURRS. MOLD FLASH OR GATE BURRS SHALL NOT EXCEED 0.15 (0.006) PER SIDE.
4. DIMENSION B DOES NOT INCLUDE INTERLEAD FLASH OR PROTRUSION. INTERLEAD FLASH OR PROTRUSION SHALL NOT EXCEED 0.25 (0.010) PER SIDE.
5. DIMENSION K DOES NOT INCLUDE DAMBAR PROTRUSION. ALLOWABLE DAMBAR PROTRUSION SHALL BE 0.08 (0.003) TOTAL IN EXCESS OF THE K DIMENSION AT MAXIMUM MATERIAL CONDITION.
6. TERMINAL NUMBERS ARE SHOWN FOR REFERENCE ONLY.
7. DIMENSION A AND B ARE TO BE DETERMINED AT DATUM PLANE -W-.

| DIM | MILLIMETERS | | INCHES | |
|-----|-------------|------|-----------|-------|
| | MIN | MAX | MIN | MAX |
| A | 6.40 | 6.60 | 0.252 | 0.260 |
| B | 4.30 | 4.50 | 0.169 | 0.177 |
| C | --- | 1.20 | --- | 0.047 |
| D | 0.05 | 0.15 | 0.002 | 0.006 |
| F | 0.50 | 0.75 | 0.020 | 0.030 |
| G | 0.65 BSC | | 0.026 BSC | |
| H | 0.27 | 0.37 | 0.011 | 0.015 |
| J | 0.09 | 0.20 | 0.004 | 0.008 |
| J1 | 0.09 | 0.16 | 0.004 | 0.006 |
| K | 0.19 | 0.30 | 0.007 | 0.012 |
| K1 | 0.19 | 0.25 | 0.007 | 0.010 |
| L | 6.40 BSC | | 0.252 BSC | |
| M | 0° | 8° | 0° | 8° |

SOLDERING FOOTPRINT

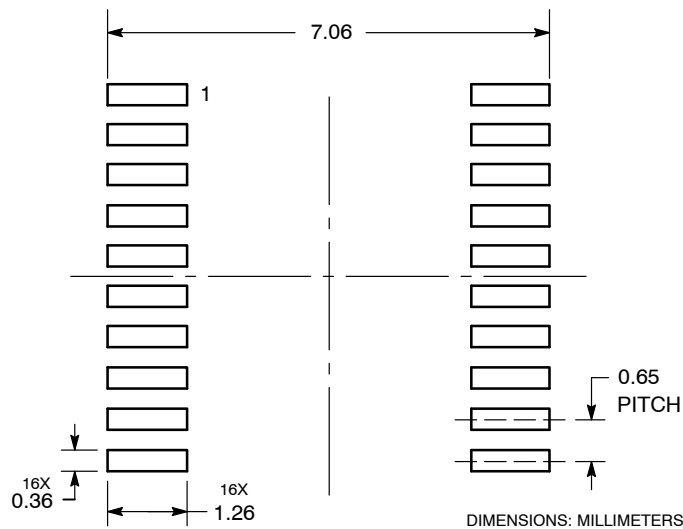

MC10EP139, MC100EP139

PACKAGE DIMENSIONS

SOIC-20 WB
CASE 751D-05
ISSUE H

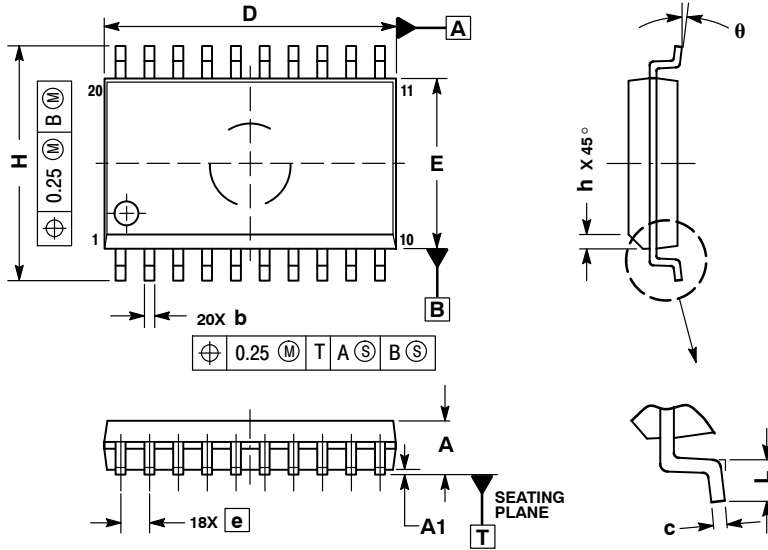

- NOTES:
1. DIMENSIONS ARE IN MILLIMETERS.
 2. INTERPRET DIMENSIONS AND TOLERANCES PER ASME Y14.5M, 1994.
 3. DIMENSIONS D AND E DO NOT INCLUDE MOLD PROTRUSION.
 4. MAXIMUM MOLD PROTRUSION 0.15 PER SIDE.
 5. DIMENSION B DOES NOT INCLUDE DAMBAR PROTRUSION. ALLOWABLE PROTRUSION SHALL BE 0.13 TOTAL IN EXCESS OF B DIMENSION AT MAXIMUM MATERIAL CONDITION.

RECOMMENDED SOLDERING FOOTPRINT*

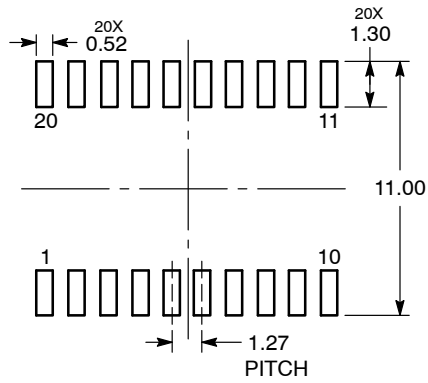

DIMENSIONS: MILLIMETERS

*For additional information on our Pb-Free strategy and soldering details, please download the ON Semiconductor Soldering and Mounting Techniques Reference Manual, SOLDERRM/D.

MC10EP139, MC100EP139

PACKAGE DIMENSIONS

QFN-20, 4x4, 0.5P
CASE 485E-01
ISSUE B

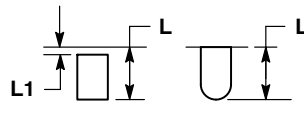
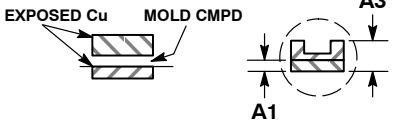
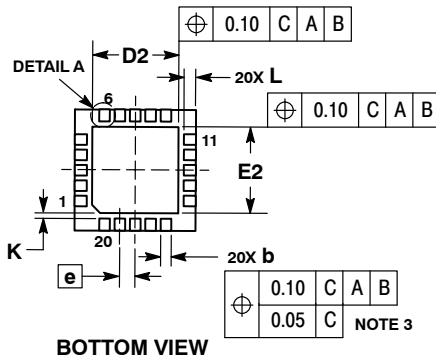
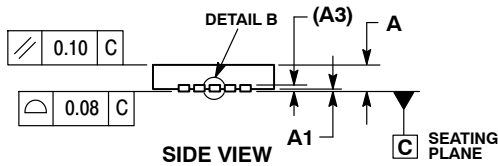
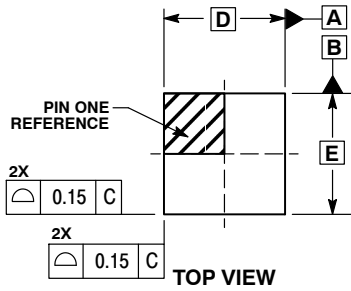

NOTES:

1. DIMENSIONING AND TOLERANCING PER ASME Y14.5M, 1994.
2. CONTROLLING DIMENSION: MILLIMETERS.
3. DIMENSION b APPLIES TO PLATED TERMINAL AND IS MEASURED BETWEEN 0.15 AND 0.30 MM FROM THE TERMINAL TIP.
4. COPLANARITY APPLIES TO THE EXPOSED PAD AS WELL AS THE TERMINALS.

| MILLIMETERS | | |
|-------------|----------|------|
| DIM | MIN | MAX |
| A | 0.80 | 1.00 |
| A1 | --- | 0.05 |
| A3 | 0.20 REF | |
| b | 0.20 | 0.30 |
| D | 4.00 BSC | |
| D2 | 2.60 | 2.90 |
| E | 4.00 BSC | |
| E2 | 2.60 | 2.90 |
| e | 0.50 BSC | |
| K | 0.20 REF | |
| L | 0.35 | 0.45 |
| L1 | 0.00 | 0.15 |

SOLDERING FOOTPRINT*

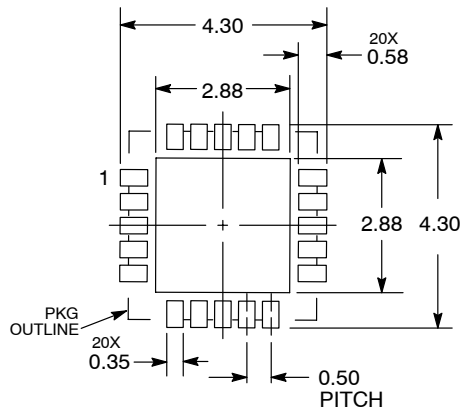

DIMENSIONS: MILLIMETERS

*For additional information on our Pb-Free strategy and soldering details, please download the ON Semiconductor Soldering and Mounting Techniques Reference Manual, SOLDERRM/D.

ECLinPS is a trademark of Semiconductor Components Industries, LLC (SCILLC) or its subsidiaries in the United States and/or other countries.

ON Semiconductor and are trademarks of Semiconductor Components Industries, LLC dba ON Semiconductor or its subsidiaries in the United States and/or other countries. ON Semiconductor owns the rights to a number of patents, trademarks, copyrights, trade secrets, and other intellectual property. A listing of ON Semiconductor's product/patent coverage may be accessed at www.onsemi.com/site/pdf/Patent-Marking.pdf. ON Semiconductor reserves the right to make changes without further notice to any products herein. ON Semiconductor makes no warranty, representation or guarantee regarding the suitability of its products for any particular purpose, nor does ON Semiconductor assume any liability arising out of the application or use of any product or circuit, and specifically disclaims any and all liability, including without limitation special, consequential or incidental damages. Buyer is responsible for its products and applications using ON Semiconductor products, including compliance with all laws, regulations and safety requirements or standards, regardless of any support or applications information provided by ON Semiconductor. "Typical" parameters which may be provided in ON Semiconductor data sheets and/or specifications can and do vary in different applications and actual performance may vary over time. All operating parameters, including "Typicals" must be validated for each customer application by customer's technical experts. ON Semiconductor does not convey any license under its patent rights nor the rights of others. ON Semiconductor products are not designed, intended, or authorized for use as a critical component in life support systems or any FDA Class 3 medical devices or medical devices with a same or similar classification in a foreign jurisdiction or any devices intended for implantation in the human body. Should Buyer purchase or use ON Semiconductor products for any such unintended or unauthorized application, Buyer shall indemnify and hold ON Semiconductor and its officers, employees, subsidiaries, affiliates, and distributors harmless against all claims, costs, damages, and expenses, and reasonable attorney fees arising out of, directly or indirectly, any claim of personal injury or death associated with such unintended or unauthorized use, even if such claim alleges that ON Semiconductor was negligent regarding the design or manufacture of the part. ON Semiconductor is an Equal Opportunity/Affirmative Action Employer. This literature is subject to all applicable copyright laws and is not for resale in any manner.

PUBLICATION ORDERING INFORMATION

LITERATURE FULFILLMENT:
Literature Distribution Center for ON Semiconductor
19521 E. 32nd Pkwy, Aurora, Colorado 80011 USA
Phone: 303-675-2175 or 800-344-3860 Toll Free USA/Canada
Fax: 303-675-2176 or 800-344-3867 Toll Free USA/Canada
Email: orderlit@onsemi.com

N. American Technical Support: 800-282-9855 Toll Free
USA/Canada
Europe, Middle East and Africa Technical Support:
Phone: 421 33 790 2910
Japan Customer Focus Center
Phone: 81-3-5817-1050

ON Semiconductor Website: www.onsemi.com
Order Literature: <http://www.onsemi.com/orderlit>

For additional information, please contact your local Sales Representative

Looking for pricing, stock, or lifecycle information?

Click below to explore more details on WIN SOURCE:

- ⊖ [View MC100EP139DWR2G on WIN SOURCE](#)
- ⊖ [ON Semiconductor Information](#)

Optimize Your Supply Chain with WIN SOURCE Solutions

- ✓ Global Sourcing Solution
- ✓ Obsolete Management
- ✓ Cost Control Management
- ✓ Shortage Management
- ✓ Alternative Solution
- ✓ Excess Inventory Management