



**THE DATASHEET OF  
MC100EP140DG**



# MC100EP140

## 3.3V ECL Phase-Frequency Detector

### Description

The MC100EP140 is a three state phase frequency–detector intended for phase–locked loop applications which require a minimum amount of phase and frequency difference at lock. Since the part is designed with fully differential internal gates, the noise is reduced throughout the circuit, especially at high speeds. The basic operation of a Phase/Frequency Detector (PFD) is to “compare” an incoming signal (feedback) to a set reference signal. When the Reference (R) and Feedback (FB) inputs are unequal in frequency and/or phase, the differential UP (U) and DOWN (D) outputs will provide pulse streams which, when subtracted and integrated, provide an error voltage for control of a VCO. Detector states of operation are shown in the Figure 2 and the State Table.

The typical output amplitude of the EP140 is 400 mV, allowing faster switching time and greater bandwidth. For proper operation, the input edge rate of the R and FB inputs should be less than 5 ns.

More information on Phase Lock Loop operation and application can be found in AND8040.

The pinout is shown in Figure 1, the logic diagram in Figure 3, and the typical termination in Figure 5.

### Features

- 500 ps Typical Propagation Delay
- Maximum Frequency > 2.1 GHz Typical
- Fully Differential Internally
- Advanced High Band Output Swing of 400 mV
- Transfer Gain: 1.0 mV/Degree at 1.4 GHz  
1.2 mV/Degree at 1.0 GHz
- Rise and Fall Time: 100 ps Typical
- The 100 Series Contains Temperature Compensation
- PECL Mode Operating Range:  $V_{CC} = 3.0\text{ V to }3.6\text{ V}$   
with  $V_{EE} = 0\text{ V}$
- NECL Mode Operating Range:  $V_{CC} = 0\text{ V}$   
with  $V_{EE} = -3.0\text{ V to }-3.6\text{ V}$
- Open Input Default State
- Pb–Free Packages are Available



ON Semiconductor®

<http://onsemi.com>

### MARKING DIAGRAMS\*



- A = Assembly Location
- L = Wafer Lot
- Y = Year
- W = Work Week
- = Pb–Free Package

\*For additional marking information, refer to Application Note AND8002/D.

### ORDERING INFORMATION

See detailed ordering and shipping information in the package dimensions section on page 5 of this data sheet.

# MC100EP140

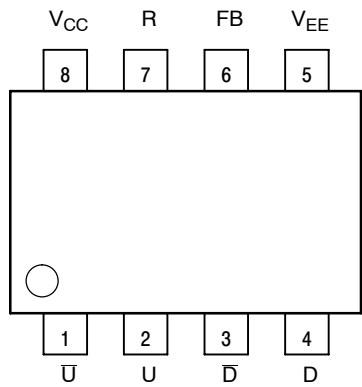

Figure 1. 8-Lead Pinout (Top View)

Table 1. PIN DESCRIPTION

PIN	FUNCTION
D, $\bar{D}$	Differential Down Outputs
U, $\bar{U}$	Differential Up Outputs
R*	ECL Reference Input
FB*	ECL Feedback Input
V <sub>CC</sub>	Positive Supply
V <sub>EE</sub>	Negative Supply

\* Pins will default LOW when left open.

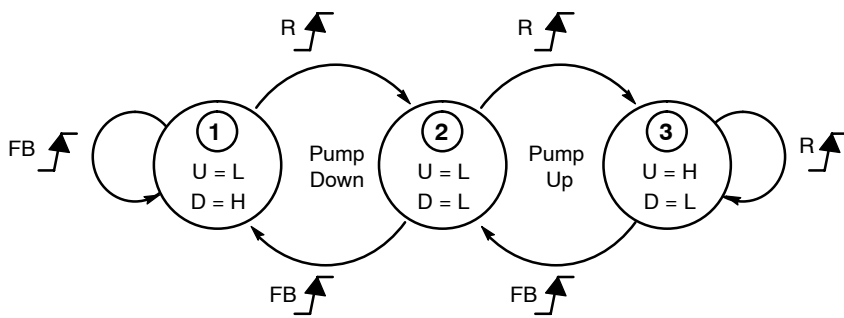

Figure 2. Phase Detector Logic Model

Table 2. STATE TABLE

PHASE DETECTOR STATE	INPUT		OUTPUT	
	R	FB	U	D
PUMP DOWN 2-1-2	2	L L	L L	L L
	2-1	L H	L H	L H
	1-2	H L	L L	L L
	2	L L	L L	L L
PUMP UP 2-3-2	2	L L	L L	L L
	2-3	H L	H L	L L
	3-2	H H	L L	L L
	2	L L	L L	L L

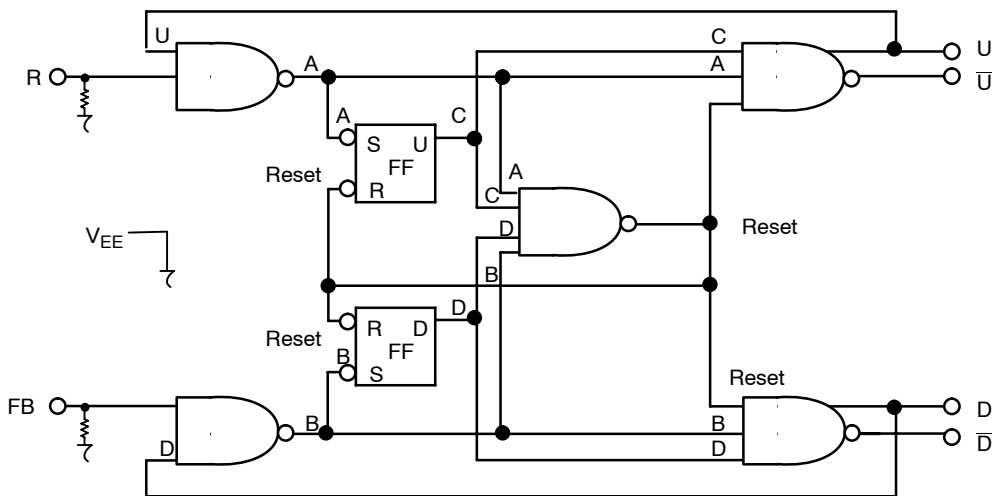

Figure 3. Logic Diagram

# MC100EP140

**Table 3. ATTRIBUTES**

Characteristics		Value	
Internal Input Pulldown Resistor		75 kΩ	
Internal Input Pullup Resistor		37.5 kΩ	
ESD Protection	Human Body Model Machine Model Charged Device Model	> 2 kV > 200 V > 2 kV	
Moisture Sensitivity, Indefinite Time Out of Drypack (Note 1)		Pb Pkg	Pb-Free Pkg
SOIC-8		Level 1	Level 1
Flammability Rating	Oxygen Index: 28 to 34	UL 94 V-0 @ 0.125 in	
Transistor Count		457 Devices	
Meets or exceeds JEDEC Spec EIA/JESD78 IC Latchup Test			

1. For additional information, see Application Note AND8003/D.

**Table 4. MAXIMUM RATINGS**

Symbol	Parameter	Condition 1	Condition 2	Rating	Unit
V <sub>CC</sub>	PECL Mode Power Supply	V <sub>EE</sub> = 0 V		6	V
V <sub>EE</sub>	NECL Mode Power Supply	V <sub>CC</sub> = 0 V		-6	V
V <sub>I</sub>	PECL Mode Input Voltage NECL Mode Input Voltage	V <sub>EE</sub> = 0 V V <sub>CC</sub> = 0 V	V <sub>I</sub> ≤ V <sub>CC</sub> V <sub>I</sub> ≥ V <sub>EE</sub>	6 -6	V V
I <sub>out</sub>	Output Current	Continuous Surge		50 100	mA mA
T <sub>A</sub>	Operating Temperature Range			-40 to +85	°C
T <sub>stg</sub>	Storage Temperature Range			-65 to +150	°C
θ <sub>JA</sub>	Thermal Resistance (Junction-to-Ambient)	0 lfpm 500 lfpm	SOIC-8 SOIC-8	190 130	°C/W °C/W
θ <sub>JC</sub>	Thermal Resistance (Junction-to-Case)	Standard Board	SOIC-8	41 to 44	°C/W
T <sub>sol</sub>	Wave Solder	Pb Pb-Free		265 265	°C

Stresses exceeding Maximum Ratings may damage the device. Maximum Ratings are stress ratings only. Functional operation above the Recommended Operating Conditions is not implied. Extended exposure to stresses above the Recommended Operating Conditions may affect device reliability.

**Table 5. 100EP DC CHARACTERISTICS, PECL V<sub>CC</sub> = 3.3 V, V<sub>EE</sub> = 0 V (Note 2)**

Symbol	Characteristic	-40°C			25°C			85°C			Unit
		Min	Typ	Max	Min	Typ	Max	Min	Typ	Max	
I <sub>EE</sub>	Power Supply Current	45	65	85	50	70	90	53	73	93	mA
V <sub>OH</sub>	Output HIGH Voltage (Note 3)	2155	2280	2405	2155	2280	2405	2155	2280	2405	mV
V <sub>OL</sub>	Output LOW Voltage (Note 3)	1755	1880	2005	1755	1880	2005	1755	1880	2005	mV
V <sub>IH</sub>	Input HIGH Voltage (Single-Ended)	2075		2420	2075		2420	2075		2420	mV
V <sub>IL</sub>	Input LOW Voltage (Single-Ended)	1355		1675	1355		1675	1355		1675	mV
I <sub>IH</sub>	Input HIGH Current			150			150			150	μA
I <sub>IL</sub>	Input LOW Current	0.5			0.5			0.5			μA

NOTE: Device will meet the specifications after thermal equilibrium has been established when mounted in a test socket or printed circuit board with maintained transverse airflow greater than 500 lfpm. Electrical parameters are guaranteed only over the declared operating temperature range. Functional operation of the device exceeding these conditions is not implied. Device specification limit values are applied individually under normal operating conditions and not valid simultaneously.

2. Input and output parameters vary 1:1 with V<sub>CC</sub>. V<sub>EE</sub> can vary +0.3 V to -0.3 V.

3. All loading with 50 Ω to V<sub>CC</sub> - 2.0 V.

# MC100EP140

**Table 6. 100EP DC CHARACTERISTICS, NECL**  $V_{CC} = 0\text{ V}$ ,  $V_{EE} = -3.6\text{ V to }-3.0\text{ V}$  (Note 4)

Symbol	Characteristic	-40°C			25°C			85°C			Unit
		Min	Typ	Max	Min	Typ	Max	Min	Typ	Max	
$I_{EE}$	Power Supply Current	45	65	85	50	70	90	53	73	93	mA
$V_{OH}$	Output HIGH Voltage (Note 5)	-1145	-1020	-895	-1145	-1020	-895	-1145	-1020	-895	mV
$V_{OL}$	Output LOW Voltage (Note 5)	-1545	-1420	-1295	-1545	-1420	-1295	-1545	-1420	-1295	mV
$V_{IH}$	Input HIGH Voltage (Single-Ended)	-1225		-880	-1225		-880	-1225		-880	mV
$V_{IL}$	Input LOW Voltage (Single-Ended)	-1945		-1625	-1945		-1625	-1945		-1625	mV
$I_{IH}$	Input HIGH Current			150			150			150	$\mu\text{A}$
$I_{IL}$	Input LOW Current	0.5			0.5			0.5			$\mu\text{A}$

NOTE: Device will meet the specifications after thermal equilibrium has been established when mounted in a test socket or printed circuit board with maintained transverse airflow greater than 500 lfpm. Electrical parameters are guaranteed only over the declared operating temperature range. Functional operation of the device exceeding these conditions is not implied. Device specification limit values are applied individually under normal operating conditions and not valid simultaneously.

4. Input and output parameters vary 1:1 with  $V_{CC}$ .  
 5. All loading with  $50\ \Omega$  to  $V_{CC} - 2.0\text{ V}$ .

**Table 7. AC CHARACTERISTICS**  $V_{CC} = 0\text{ V}$ ;  $V_{EE} = -3.0\text{ V to }-3.6\text{ V}$  or  $V_{CC} = 3.0\text{ V to }3.6\text{ V}$ ;  $V_{EE} = 0\text{ V}$  (Note 6)

Symbol	Characteristic	-40°C			25°C			85°C			Unit
		Min	Typ	Max	Min	Typ	Max	Min	Typ	Max	
$f_{\text{max}}$	Maximum Frequency (Figure 4)		> 2			> 2			> 2		GHz
$t_{PLH}$ , $t_{PHL}$	Propagation Delay to Output Differential R to U, FB to D FB to U, R to D	300 400	450 600	6002 800	325 450	475 650	625 850	350 500	500 700	650 900	ps
$t_{\text{JITTER}}$	Cycle-to-Cycle Jitter (Figure 4)		.2	< 1		.2	< 1		.2	< 1	ps
$V_{PP}$	Input Voltage Swing	400	800	1200	400	800	1200	400	800	1200	mV
$t_r$ , $t_f$	Output Rise/Fall Times (20% - 80%) Q, $\bar{Q}$	50	90	180	60	100	200	70	120	220	ps

NOTE: Device will meet the specifications after thermal equilibrium has been established when mounted in a test socket or printed circuit board with maintained transverse airflow greater than 500 lfpm. Electrical parameters are guaranteed only over the declared operating temperature range. Functional operation of the device exceeding these conditions is not implied. Device specification limit values are applied individually under normal operating conditions and not valid simultaneously.

6. Measured using a 750 mV  $V_{PP}$  pk-pk, 50% duty cycle, clock source. All loading with  $50\ \Omega$  to  $V_{CC} - 2.0\text{ V}$ .

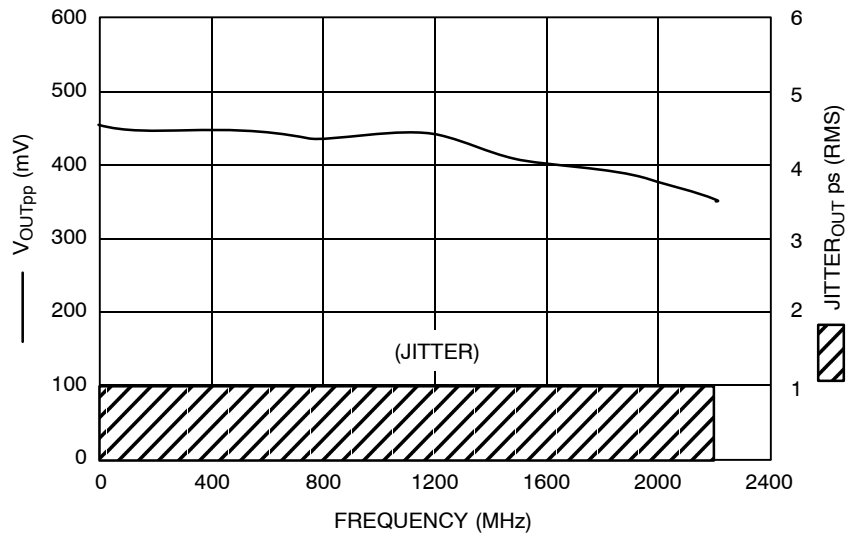

**Figure 4.  $F_{\text{max}}$ /Jitter**

## MC100EP140

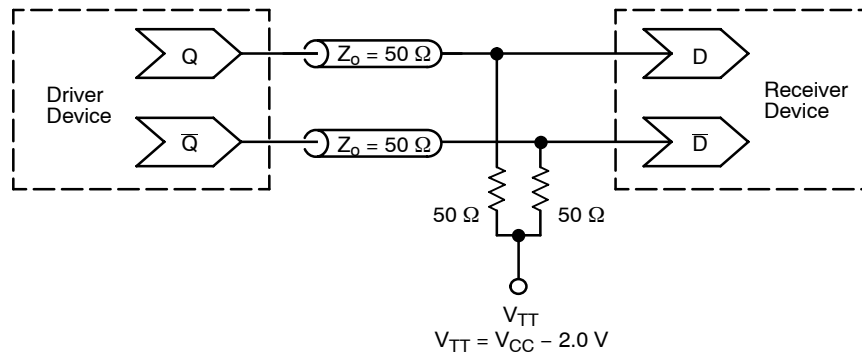

**Figure 5. Typical Termination for Output Driver and Device Evaluation  
(See Application Note AND8020/D – Termination of ECL Logic Devices.)**

### ORDERING INFORMATION

Device	Package	Shipping <sup>†</sup>
MC100EP140D	SOIC-8	98 Units / Rail
MC100EP140DG	SOIC-8 (Pb-Free)	98 Units / Rail
MC100EP140DR2	SOIC-8	2500 / Tape & Reel
MC100EP140DR2G	SOIC-8 (Pb-Free)	2500 / Tape & Reel

<sup>†</sup>For information on tape and reel specifications, including part orientation and tape sizes, please refer to our Tape and Reel Packaging Specifications Brochure, BRD8011/D.

### Resource Reference of Application Notes

- AN1405/D** – ECL Clock Distribution Techniques
- AN1406/D** – Designing with PECL (ECL at +5.0 V)
- AN1503/D** – ECLinPS™ I/O SPiCE Modeling Kit
- AN1504/D** – Metastability and the ECLinPS Family
- AN1568/D** – Interfacing Between LVDS and ECL
- AN1672/D** – The ECL Translator Guide
- AND8001/D** – Odd Number Counters Design
- AND8002/D** – Marking and Date Codes
- AND8020/D** – Termination of ECL Logic Devices
- AND8066/D** – Interfacing with ECLinPS
- AND8090/D** – AC Characteristics of ECL Devices

# MC100EP140

## PACKAGE DIMENSIONS

SOIC-8 NB  
CASE 751-07  
ISSUE AH

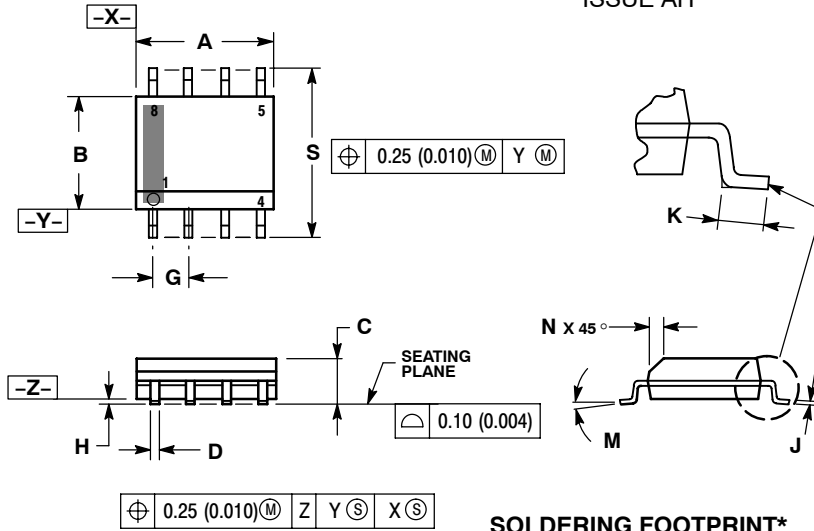

**NOTES:**

1. DIMENSIONING AND TOLERANCING PER ANSI Y14.5M, 1982.
2. CONTROLLING DIMENSION: MILLIMETER.
3. DIMENSION A AND B DO NOT INCLUDE MOLD PROTRUSION.
4. MAXIMUM MOLD PROTRUSION 0.15 (0.006) PER SIDE.
5. DIMENSION D DOES NOT INCLUDE DAMBAR PROTRUSION. ALLOWABLE DAMBAR PROTRUSION SHALL BE 0.127 (0.005) TOTAL IN EXCESS OF THE D DIMENSION AT MAXIMUM MATERIAL CONDITION.
6. 751-01 THRU 751-06 ARE OBSOLETE. NEW STANDARD IS 751-07.

DIM	MILLIMETERS		INCHES	
	MIN	MAX	MIN	MAX
A	4.80	5.00	0.189	0.197
B	3.80	4.00	0.150	0.157
C	1.35	1.75	0.053	0.069
D	0.33	0.51	0.013	0.020
G	1.27 BSC		0.050 BSC	
H	0.10	0.25	0.004	0.010
J	0.19	0.25	0.007	0.010
K	0.40	1.27	0.016	0.050
M	0°	8°	0°	8°
N	0.25	0.50	0.010	0.020
S	5.80	6.20	0.228	0.244

### SOLDERING FOOTPRINT\*

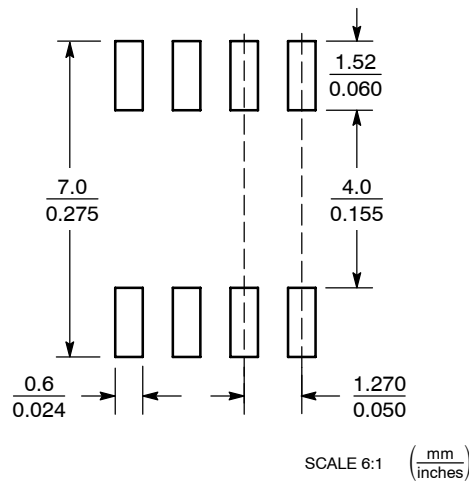

\*For additional information on our Pb-Free strategy and soldering details, please download the ON Semiconductor Soldering and Mounting Techniques Reference Manual, SOLDERRM/D.

ECLinPS is a trademark of Semiconductor Components Industries, LLC (SCILLC).

ON Semiconductor and are registered trademarks of Semiconductor Components Industries, LLC (SCILLC). SCILLC reserves the right to make changes without further notice to any products herein. SCILLC makes no warranty, representation or guarantee regarding the suitability of its products for any particular purpose, nor does SCILLC assume any liability arising out of the application or use of any product or circuit, and specifically disclaims any and all liability, including without limitation special, consequential or incidental damages. "Typical" parameters which may be provided in SCILLC data sheets and/or specifications can and do vary in different applications and actual performance may vary over time. All operating parameters, including "Typicals" must be validated for each customer application by customer's technical experts. SCILLC does not convey any license under its patent rights nor the rights of others. SCILLC products are not designed, intended, or authorized for use as components in systems intended for surgical implant into the body, or other applications intended to support or sustain life, or for any other application in which the failure of the SCILLC product could create a situation where personal injury or death may occur. Should Buyer purchase or use SCILLC products for any such unintended or unauthorized application, Buyer shall indemnify and hold SCILLC and its officers, employees, subsidiaries, affiliates, and distributors harmless against all claims, costs, damages, and expenses, and reasonable attorney fees arising out of, directly or indirectly, any claim of personal injury or death associated with such unintended or unauthorized use, even if such claim alleges that SCILLC was negligent regarding the design or manufacture of the part. SCILLC is an Equal Opportunity/Affirmative Action Employer. This literature is subject to all applicable copyright laws and is not for resale in any manner.

### PUBLICATION ORDERING INFORMATION

**LITERATURE FULFILLMENT:**  
Literature Distribution Center for ON Semiconductor  
P.O. Box 5163, Denver, Colorado 80217 USA  
Phone: 303-675-2175 or 800-344-3860 Toll Free USA/Canada  
Fax: 303-675-2176 or 800-344-3867 Toll Free USA/Canada  
Email: orderlit@onsemi.com

**N. American Technical Support:** 800-282-9855 Toll Free USA/Canada  
**Europe, Middle East and Africa Technical Support:**  
Phone: 421 33 790 2910  
**Japan Customer Focus Center**  
Phone: 81-3-5773-3850

**ON Semiconductor Website:** [www.onsemi.com](http://www.onsemi.com)  
**Order Literature:** <http://www.onsemi.com/orderlit>

For additional information, please contact your local Sales Representative

## Looking for pricing, stock, or lifecycle information?

Click below to explore more details on WIN SOURCE:

 [View MC100EP140DG on WIN SOURCE](#)

 [ON Semiconductor](#) Information

## Optimize Your Supply Chain with WIN SOURCE Solutions

-  Global Sourcing Solution
-  Obsolete Management
-  Cost Control Management
-  Shortage Management
-  Alternative Solution
-  Excess Inventory Management