

MC10H136

Universal Hexadecimal Counter

Description

The MC10H136 is a high speed synchronous hexadecimal counter. This 10H part is a functional/pinout duplication of the standard MECL 10K™ family part, with 100% improvement in counting frequency and no increase in power-supply current.

Features

- Counting Frequency, 250 MHz Minimum
- Power Dissipation, 625 mW Typical
- Improved Noise Margin 150 mV
(Over Operating Voltage and Temperature Range)
- Voltage Compensated
- MECL 10K Compatible
- These Devices are Pb-Free, Halogen Free and are RoHS Compliant



ON Semiconductor®

www.onsemi.com

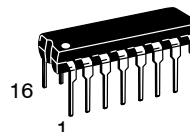

**PDIP-16
P SUFFIX
CASE 648-08**

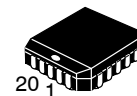

**PLCC-20
FN SUFFIX
CASE 775-02**

MARKING DIAGRAMS*

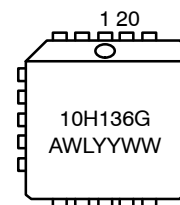
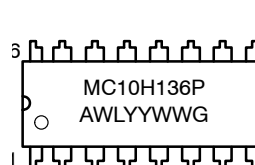

- A = Assembly Location
- WL = Wafer Lot
- YY = Year
- WW = Work Week
- G = Pb-Free Package

*For additional marking information, refer to Application Note [AND8002/D](#).

ORDERING INFORMATION

| Device | Package | Shipping† |
|-------------|----------------------|---------------|
| MC10H136FNG | PLCC-28 (Pb-Free) | 46 Units/Tube |
| MC10H136PG | PDIP-16 (Pb-Free) | 25 Units/Tube |

†For information on tape and reel specifications, including part orientation and tape sizes, please refer to our Tape and Reel Packaging Specifications Brochure, [BRD8011/D](#).

MC10H136

Table 1. FUNCTION SELECT TABLE

| CIN | S1 | S2 | Operating Mode |
|-----|----|----|------------------------|
| X | L | L | Preset (Program) |
| L | L | H | Increment (Count Up) |
| H | L | H | Hold Count |
| L | H | L | Decrement (Count Down) |
| H | H | L | Hold Count |
| X | H | H | Hold (Stop Count) |

Table 2. SEQUENTIAL TRUTH TABLE*

| INPUTS | | | | | | | | OUTPUTS | | | | |
|--------|----|----|----|----|----|----------|----------|---------|----|----|----|-----------|
| S1 | S2 | D0 | D1 | D2 | D3 | Carry In | Clock ** | Q0 | Q1 | Q2 | Q3 | Carry Out |
| L | L | L | L | H | H | X | H | L | L | H | H | L |
| L | H | X | X | X | X | L | H | H | L | H | H | H |
| L | H | X | X | X | X | L | H | L | H | H | H | H |
| L | H | X | X | X | X | L | H | H | H | H | H | L |
| L | H | X | X | X | X | H | L | H | H | H | H | H |
| L | H | X | X | X | X | H | H | H | H | H | H | H |
| H | H | X | X | X | X | X | H | H | H | H | H | H |
| L | L | H | H | L | L | X | H | H | H | L | L | L |
| H | L | X | X | X | X | L | H | L | H | L | L | H |
| H | L | X | X | X | X | L | H | H | L | L | L | L |
| H | L | X | X | X | X | L | H | L | L | L | L | L |
| H | L | X | X | X | X | L | H | H | H | H | H | H |

* Truth table shows logic states assuming inputs vary in sequence shown from top to bottom.

** A clock H is defined as a clock input transition from a low to a high logic level.

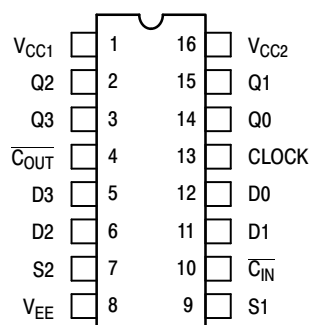

Pin assignment is for Dual-in-Line Package.

Figure 1. Pin Assignment

Table 3. MAXIMUM RATINGS

| Symbol | Characteristic | Rating | Unit |
|-----------|---|----------------------------|------|
| V_{EE} | Power Supply ($V_{CC} = 0$) | -8.0 to 0 | Vdc |
| V_I | Input Voltage ($V_{CC} = 0$) | 0 to V_{EE} | Vdc |
| I_{out} | Output Current Continuous Surge | 50 100 | mA |
| T_A | Operating Temperature Range | 0 to +75 | °C |
| T_{stg} | Storage Temperature Range Plastic Ceramic | -55 to +150 -55 to +165 | °C |

Stresses exceeding those listed in the Maximum Ratings table may damage the device. If any of these limits are exceeded, device functionality should not be assumed, damage may occur and reliability may be affected.

Table 4. ELECTRICAL CHARACTERISTICS ($V_{EE} = -5.2 \text{ V} \pm 5\%$) (Note 1)

| Symbol | Characteristic | 0° | | 25° | | 75° | | Unit |
|-----------|---|-------|-------|-------|-------|-------|--------|---------------|
| | | Min | Max | Min | Max | Min | Max | |
| I_E | Power Supply Current | - | 165 | - | 150 | - | 165 | mA |
| I_{inH} | Input Current High Pins 5, 6, 11, 12, 13 | - | 430 | - | 275 | - | 275 | μA |
| | Pin 9 | - | 670 | - | 420 | - | 420 | |
| | Pin 7 | - | 535 | - | 335 | - | 335 | |
| | Pin 10 | - | 380 | - | 240 | - | 240 | |
| I_{inL} | Input Current Low | 0.5 | - | 0.5 | - | 0.3 | - | μA |
| V_{OH} | High Output Voltage | -1.02 | -0.84 | -0.98 | -0.81 | -0.92 | -0.735 | Vdc |
| V_{OL} | Low Output Voltage | -1.95 | -1.63 | -1.95 | -1.63 | -1.95 | -1.60 | Vdc |
| V_{IH} | High Input Voltage | -1.17 | -0.84 | -1.13 | -0.81 | -1.07 | -0.735 | Vdc |
| V_{IL} | Low Input Voltage | -1.95 | -1.48 | -1.95 | -1.48 | -1.95 | -1.45 | Vdc |

- Each MECL 10H™ series circuit has been designed to meet the dc specifications shown in the test table, after thermal equilibrium has been established. The circuit is in a test socket or mounted on a printed circuit board and transverse air flow greater than 500 lfpm is maintained. Outputs are terminated through a 50 Ω resistor to -2.0 V.

MC10H136

Table 5. AC CHARACTERISTICS

| Symbol | Characteristic | 0° | | 25° | | 75° | | Unit |
|-------------|--|------|-----|------|-----|------|-----|------|
| | | Min | Max | Min | Max | Min | Max | |
| t_{pd} | Propagation Delay | 0.7 | 2.3 | 0.7 | 2.4 | 0.7 | 2.5 | ns |
| | Clock to Q | 1.0 | 4.8 | 1.0 | 4.9 | 1.0 | 5.0 | |
| | Clock to Carry Out Carry in to Carry Out | 0.7 | 2.5 | 0.7 | 2.6 | 0.7 | 2.7 | |
| t_{set} | Set-up Time | 2.0 | - | 2.0 | - | 2.0 | - | ns |
| | Data (D0 to C) | 3.5 | - | 3.5 | - | 3.5 | - | |
| | Select (S to C) | 2.0 | - | 2.0 | - | 2.0 | - | |
| | Carry In (C_{in} to C) (C to C_{in}) | 0 | - | 0 | - | 0 | - | |
| t_{hold} | Hold Time | 0 | - | 0 | - | 0 | - | ns |
| | Data (C to D0) | -0.5 | - | -0.5 | - | -0.5 | - | |
| | Select (C to S) | 0 | - | 0 | - | 0 | - | |
| | Carry In (C to C_{in}) (C_{in} to C) | 2.2 | - | 2.2 | - | 2.2 | - | |
| f_{count} | Counting Frequency | 250 | - | 250 | - | 250 | - | MHz |
| t_r | Rise Time | 0.5 | 2.3 | 0.5 | 2.4 | 0.5 | 2.5 | ns |
| t_f | Fall Time | 0.5 | 2.3 | 0.5 | 2.4 | 0.5 | 2.5 | ns |

NOTE: Device will meet the specifications after thermal equilibrium has been established when mounted in a test socket or printed circuit board with maintained transverse airflow greater than 500 lfm. Electrical parameters are guaranteed only over the declared operating temperature range. Functional operation of the device exceeding these conditions is not implied. Device specification limit values are applied individually under normal operating conditions and not valid simultaneously.

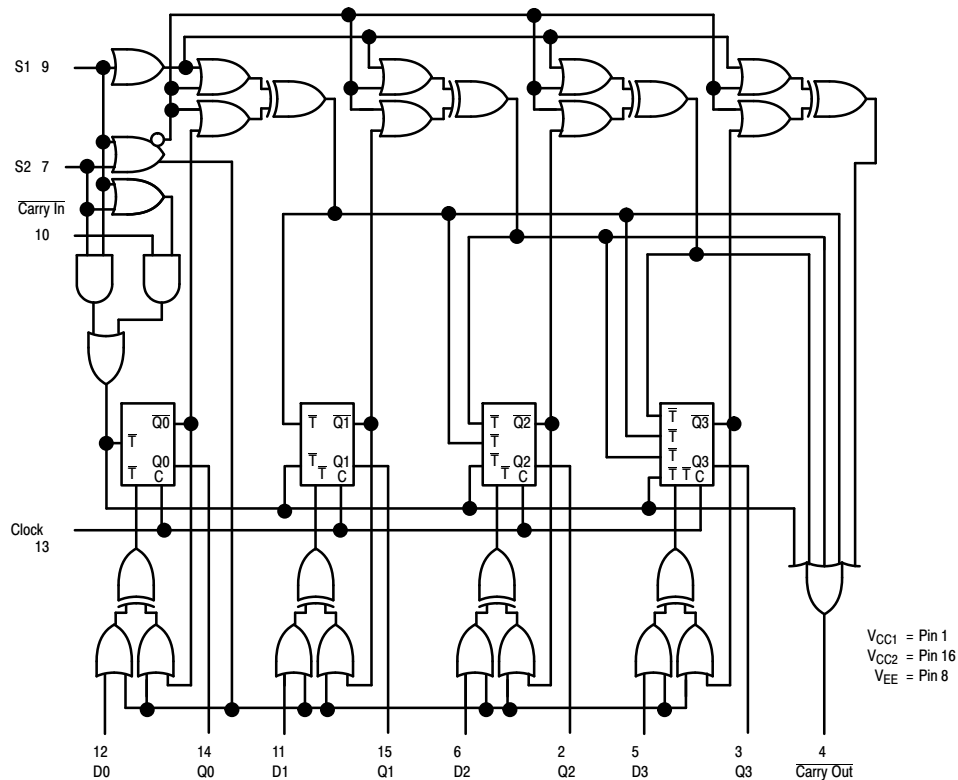

NOTE: FLIP-FLOPS WILL TOGGLE WHEN ALL T INPUTS ARE LOW.

Figure 2. Logic Diagram

MC10H136

APPLICATION INFORMATION

The MC10H136 is a high speed synchronous counter that operates at 250 MHz. Counter operating modes include count up, count down, pre-set and hold count. This device allows the designer to use one basic counter for many applications.

The S1, S2, control lines determine the operating modes of the counter. In the pre-set mode, a clock pulse is necessary to load the counter with the information present on the data inputs (D0, D1, D2, and D3). Carry out goes low on the terminal count or when the counter is being pre-set.

MC10H136

PACKAGE DIMENSIONS

20 LEAD PLLC
CASE 775-02
ISSUE F

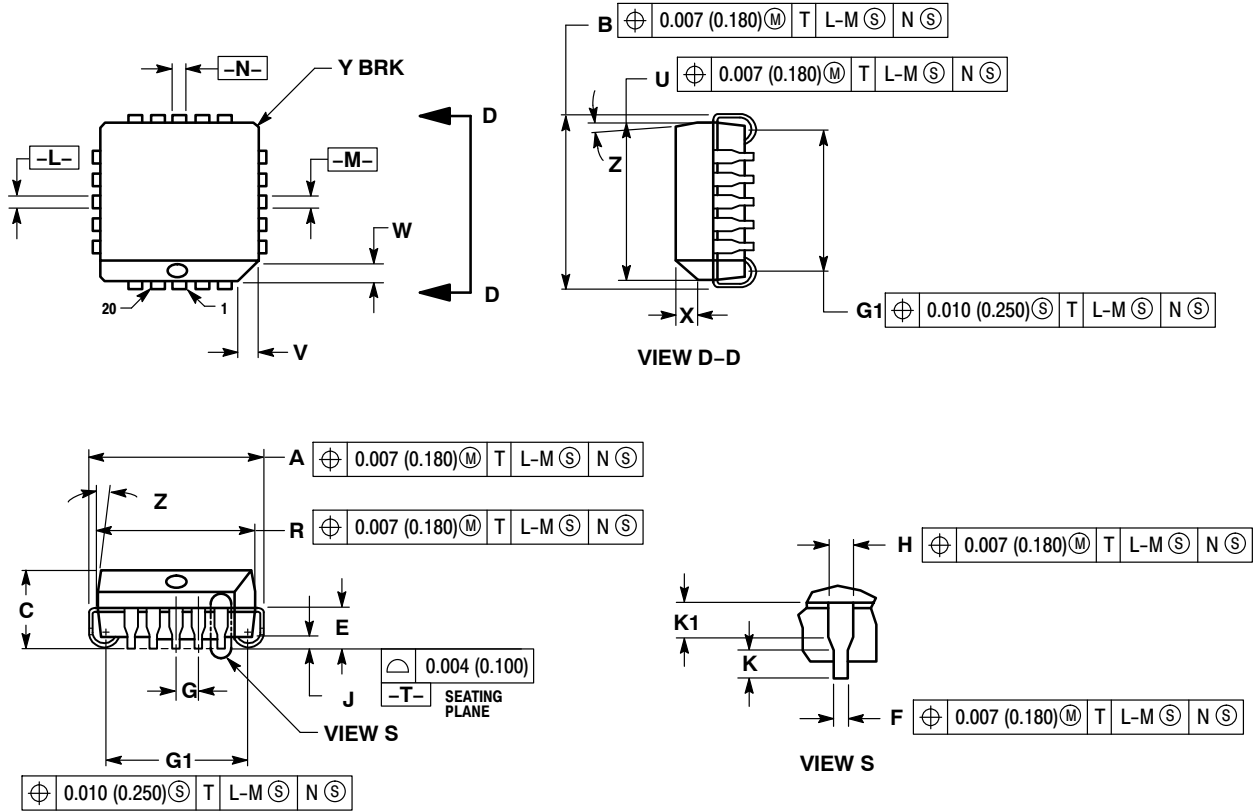

NOTES:

1. DIMENSIONS AND TOLERANCING PER ANSI Y14.5M, 1982.
2. DIMENSIONS IN INCHES.
3. DATUMS -L-, -M-, AND -N- DETERMINED WHERE TOP OF LEAD SHOULDER EXITS PLASTIC BODY AT MOLD PARTING LINE.
4. DIMENSION G1, TRUE POSITION TO BE MEASURED AT DATUM -T-, SEATING PLANE.
5. DIMENSIONS R AND U DO NOT INCLUDE MOLD FLASH. ALLOWABLE MOLD FLASH IS 0.010 (0.250) PER SIDE.
6. DIMENSIONS IN THE PACKAGE TOP MAY BE SMALLER THAN THE PACKAGE BOTTOM BY UP TO 0.012 (0.300). DIMENSIONS R AND U ARE DETERMINED AT THE OUTERMOST EXTREMES OF THE PLASTIC BODY EXCLUSIVE OF MOLD FLASH, TIE BAR BURRS, GATE BURRS AND INTERLEAD FLASH, BUT INCLUDING ANY MISMATCH BETWEEN THE TOP AND BOTTOM OF THE PLASTIC BODY.
7. DIMENSION H DOES NOT INCLUDE DAMBAR PROTRUSION OR INTRUSION. THE DAMBAR PROTRUSION(S) SHALL NOT CAUSE THE H DIMENSION TO BE GREATER THAN 0.037 (0.940). THE DAMBAR INTRUSION(S) SHALL NOT CAUSE THE H DIMENSION TO BE SMALLER THAN 0.025 (0.635).

| DIM | INCHES | | MILLIMETERS | |
|-----|-----------|-------|-------------|-------|
| | MIN | MAX | MIN | MAX |
| A | 0.385 | 0.395 | 9.78 | 10.03 |
| B | 0.385 | 0.395 | 9.78 | 10.03 |
| C | 0.165 | 0.180 | 4.20 | 4.57 |
| E | 0.090 | 0.110 | 2.29 | 2.79 |
| F | 0.013 | 0.021 | 0.33 | 0.53 |
| G | 0.050 BSC | | 1.27 BSC | |
| H | 0.026 | 0.032 | 0.66 | 0.81 |
| J | 0.020 | ---- | 0.51 | ---- |
| K | 0.025 | ---- | 0.64 | ---- |
| R | 0.350 | 0.356 | 8.89 | 9.04 |
| U | 0.350 | 0.356 | 8.89 | 9.04 |
| V | 0.042 | 0.048 | 1.07 | 1.21 |
| W | 0.042 | 0.048 | 1.07 | 1.21 |
| X | 0.042 | 0.056 | 1.07 | 1.42 |
| Y | ---- | 0.020 | ---- | 0.50 |
| Z | 2° 10° | | 2° 10° | |
| G1 | 0.310 | 0.330 | 7.88 | 8.38 |
| K1 | 0.040 | ---- | 1.02 | ---- |

MC10H136

PACKAGE DIMENSIONS

PDIP-16
CASE 648-08
ISSUE V

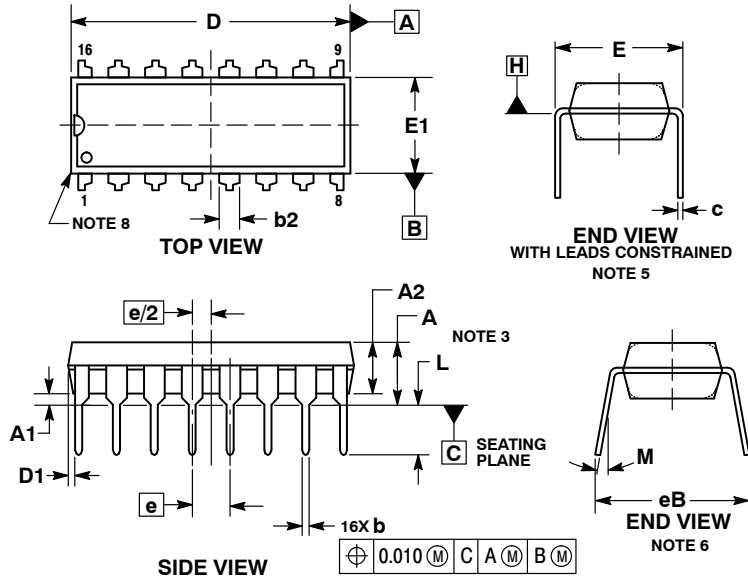

NOTES:

1. DIMENSIONING AND TOLERANCING PER ASME Y14.5M, 1994.
2. CONTROLLING DIMENSION: INCHES.
3. DIMENSIONS A, A1 AND L ARE MEASURED WITH THE PACKAGE SEATED IN JEDEC SEATING PLANE GAUGE GS-3.
4. DIMENSIONS D, D1 AND E1 DO NOT INCLUDE MOLD FLASH OR PROTRUSIONS. MOLD FLASH OR PROTRUSIONS ARE NOT TO EXCEED 0.10 INCH.
5. DIMENSION E IS MEASURED AT A POINT 0.015 BELOW DATUM PLANE H WITH THE LEADS CONSTRAINED PERPENDICULAR TO DATUM C.
6. DIMENSION eB IS MEASURED AT THE LEAD TIPS WITH THE LEADS UNCONSTRAINED.
7. DATUM PLANE H IS COINCIDENT WITH THE BOTTOM OF THE LEADS, WHERE THE LEADS EXIT THE BODY.
8. PACKAGE CONTOUR IS OPTIONAL (ROUNDED OR SQUARE CORNERS).

STYLE 1:

- PIN 1. CATHODE
- CATHODE
- CATHODE
- CATHODE
- CATHODE
- CATHODE
- CATHODE
- CATHODE
- ANODE
- ANODE
- ANODE
- ANODE
- ANODE
- ANODE
- ANODE
- ANODE

STYLE 2:

- PIN 1. COMMON DRAIN
- COMMON DRAIN
- COMMON DRAIN
- COMMON DRAIN
- COMMON DRAIN
- COMMON DRAIN
- COMMON DRAIN
- COMMON DRAIN
- GATE
- SOURCE
- GATE
- SOURCE
- GATE
- SOURCE
- GATE
- SOURCE

MECL is a trademark of Semiconductor Components Industries, LLC (SCILLC) or its subsidiaries in the United States and/or other countries.

ON Semiconductor and are trademarks of Semiconductor Components Industries, LLC dba ON Semiconductor or its subsidiaries in the United States and/or other countries. ON Semiconductor owns the rights to a number of patents, trademarks, copyrights, trade secrets, and other intellectual property. A listing of ON Semiconductor's product/patent coverage may be accessed at www.onsemi.com/site/pdf/Patent-Marketing.pdf. ON Semiconductor reserves the right to make changes without further notice to any products herein. ON Semiconductor makes no warranty, representation or guarantee regarding the suitability of its products for any particular purpose, nor does ON Semiconductor assume any liability arising out of the application or use of any product or circuit, and specifically disclaims any and all liability, including without limitation special, consequential or incidental damages. Buyer is responsible for its products and applications using ON Semiconductor products, including compliance with all laws, regulations and safety requirements or standards, regardless of any support or applications information provided by ON Semiconductor. "Typical" parameters which may be provided in ON Semiconductor data sheets and/or specifications can and do vary in different applications and actual performance may vary over time. All operating parameters, including "Typicals" must be validated for each customer application by customer's technical experts. ON Semiconductor does not convey any license under its patent rights nor the rights of others. ON Semiconductor products are not designed, intended, or authorized for use as a critical component in life support systems or any FDA Class 3 medical devices or medical devices with a same or similar classification in a foreign jurisdiction or any devices intended for implantation in the human body. Should Buyer purchase or use ON Semiconductor products for any such unintended or unauthorized application, Buyer shall indemnify and hold ON Semiconductor and its officers, employees, subsidiaries, affiliates, and distributors harmless against all claims, costs, damages, and expenses, and reasonable attorney fees arising out of, directly or indirectly, any claim of personal injury or death associated with such unintended or unauthorized use, even if such claim alleges that ON Semiconductor was negligent regarding the design or manufacture of the part. ON Semiconductor is an Equal Opportunity/Affirmative Action Employer. This literature is subject to all applicable copyright laws and is not for resale in any manner.

PUBLICATION ORDERING INFORMATION

LITERATURE FULFILLMENT:

Literature Distribution Center for ON Semiconductor
19521 E. 32nd Pkwy, Aurora, Colorado 80011 USA
Phone: 303-675-2175 or 800-344-3860 Toll Free USA/Canada
Fax: 303-675-2176 or 800-344-3867 Toll Free USA/Canada
Email: orderlit@onsemi.com

N. American Technical Support: 800-282-9855 Toll Free
USA/Canada
Europe, Middle East and Africa Technical Support:
Phone: 421 33 790 2910
Japan Customer Focus Center
Phone: 81-3-5817-1050

ON Semiconductor Website: www.onsemi.com

Order Literature: <http://www.onsemi.com/orderlit>

For additional information, please contact your local Sales Representative

Looking for pricing, stock, or lifecycle information?

Click below to explore more details on WIN SOURCE:

 [View MC10H136FNR2G on WIN SOURCE](#)

 [ON Semiconductor](#) Information

Optimize Your Supply Chain with WIN SOURCE Solutions

-  Global Sourcing Solution
-  Obsolete Management
-  Cost Control Management
-  Shortage Management
-  Alternative Solution
-  Excess Inventory Management