



**THE DATASHEET OF
MC10H606FNR2**



MC10H606, MC100H606

Registered Hex TTL to PECL Translator

Description

The MC10/100H606 is a 6-bit, registered, single supply TTL to PECL translator. The device features differential PECL outputs as well as a choice between either a differential PECL clock input or a TTL clock input. The asynchronous master reset control is a PECL level input.

With its differential PECL outputs and TTL inputs the H606 device is ideally suited for the transmit function of a HPPI bus type board-to-board interface application. The on chip registers simplify the task of synchronizing the data between the two boards.

The device is available in either ECL standard: the MECL 10H™ device is compatible with MECL 10KH logic levels, with a V_{CC} of +5.0 V while the 100H device is compatible with 100K logic levels, with a V_{CC} of +5.0 V.

Features

- Differential 50 Ω ECL Outputs
- Choice Between Differential PECL or TTL Clock Input
- Single Power Supply
- Multiple Power and Ground Pins to Minimize Noise
- Pb-Free Packages are Available*



ON Semiconductor®

<http://onsemi.com>

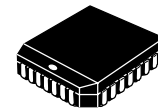

**PLCC-28
FN SUFFIX
CASE 776**

MARKING DIAGRAM*

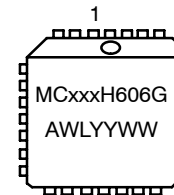

xxx = 10 or 100
A = Assembly Location
WL = Wafer Lot
YY = Year
WW = Work Week
G = Pb-Free Package

*For additional marking information, refer to Application Note AND8002/D.

ORDERING INFORMATION

See detailed ordering and shipping information in the package dimensions section on page 5 of this data sheet.

*For additional information on our Pb-Free strategy and soldering details, please download the ON Semiconductor Soldering and Mounting Techniques Reference Manual, SOLDERRM/D.

MC10H606, MC100H606

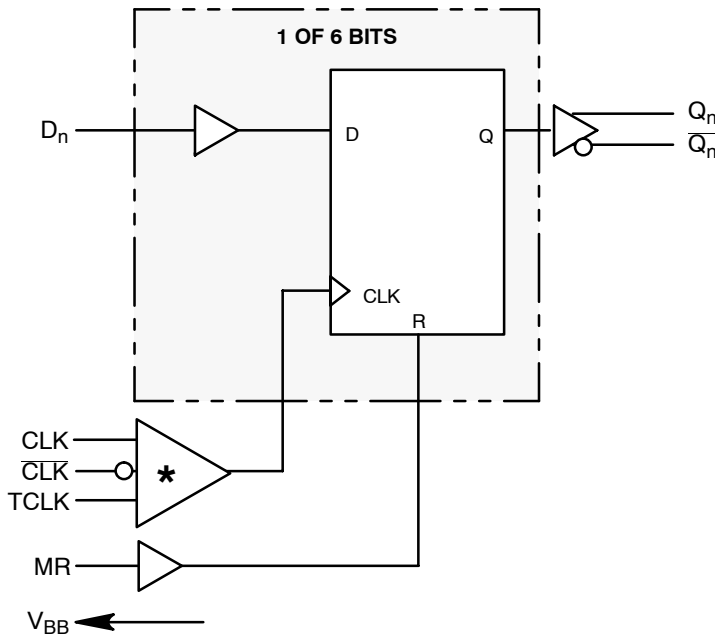

Table 1. TRUTH TABLE

D _n	MR	TCLK/CLK	Q _{n+1}
L	L	Z	L
H	L	Z	H
X	H	X	L

Z = LOW to HIGH Transition

- * 1. When using PECL inputs, TCLK must be tied to ground (0 V).
- 2. When using only one PECL input, the unused PECL input must be tied to V_{BB}, and TCLK must be tied to ground (0 V).
- 3. When using TCLK, both PECL inputs must be tied to ground (0 V).

Figure 1. Logic Diagram

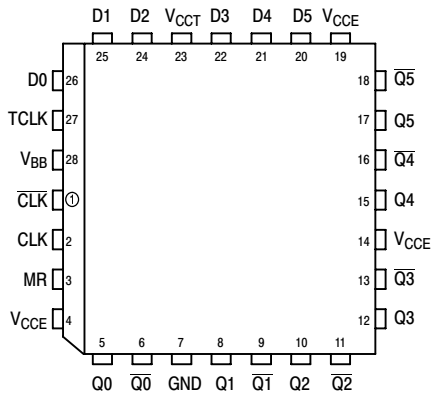

**Figure 2. Pinout: PLCC-28
(Top View)**

Table 2. PIN NAMES

PIN	FUNCTION
D0 - D5	TTL Data Inputs
CLK, CLK	Differential PECL Clock Input
TCLK	TTL Clock Input
MR	PECL Master Reset Input
Q0 - Q5	True PECL Outputs
Q0 - Q5	Inverted PECL Outputs
V _{CCE}	PECL V _{CC} (+5.0 V)
V _{CCT}	TTL V _{CC} (+5.0 V)
GND	TTL/PECL Ground

MC10H606, MC100H606

Table 3. 10H PECL DC CHARACTERISTICS ($V_{CCT} = V_{CCE} = 5.0\text{ V} \pm 5\%$)

Symbol	Characteristic	Condition	$T_A = 0^\circ\text{C}$		$T_A = 25^\circ\text{C}$		$T_A = 85^\circ\text{C}$		Unit
			Min	Max	Min	Max	Min	Max	
I_{INH}	Input HIGH Current			255		175		175	μA
I_{INL}	Input LOW Current			0.5		0.5		0.5	μA
V_{IH}	Input HIGH Voltage (Note 4)	$V_{CCT} = 5.0\text{ V}$	3830	4160	3870	4190	3930	4280	mV
V_{IL}	Input LOW Voltage (Note 4)	$V_{CCT} = 5.0\text{ V}$	3050	3520	3050	3520	3050	3555	mV
V_{OH}	Output HIGH Voltage (Note 4)	$V_{CCT} = 5.0\text{ V}$	3980	4160	4020	4190	4080	4270	mV
V_{OL}	Output LOW Voltage (Note 4)	$V_{CCT} = 5.0\text{ V}$	3050	3370	3050	3370	3050	3400	mV
V_{BB}	Reference Voltage (Note 4)	$V_{CCT} = 5.0\text{ V}$	3600	3710	3630	3730	3670	3790	mV

NOTE: Device will meet the specifications after thermal equilibrium has been established when mounted in a test socket or printed circuit board with maintained transverse airflow greater than 500 lfm. Electrical parameters are guaranteed only over the declared operating temperature range. Functional operation of the device exceeding these conditions is not implied. Device specification limit values are applied individually under normal operating conditions and not valid simultaneously.

4. PECL V_{IL} , V_{IH} , V_{OL} , V_{OH} , V_{BB} are given for $V_{CCT} = V_{CCE} = 5.0\text{ V}$ and will vary 1:1 with the power supply.

Table 4. 100H PECL DC CHARACTERISTICS ($V_{CCT} = V_{CCE} = 5.0\text{ V} \pm 5\%$)

Symbol	Characteristic	Condition	$T_A = 0^\circ\text{C}$		$T_A = 25^\circ\text{C}$		$T_A = 85^\circ\text{C}$		Unit
			Min	Max	Min	Max	Min	Max	
I_{INH}	Input HIGH Current			255		175		175	μA
I_{INL}	Input LOW Current			0.5		0.5		0.5	μA
V_{IH}	Input HIGH Voltage (Note 5)	$V_{CCT} = 5.0\text{ V}$	3835	4120	3835	4120	3835	4120	mV
V_{IL}	Input LOW Voltage (Note 5)	$V_{CCT} = 5.0\text{ V}$	3190	3525	3190	3525	3190	3525	mV
V_{OH}	Output HIGH Voltage (Note 5)	$V_{CCT} = 5.0\text{ V}$	3975	4120	3975	4120	3975	4120	mV
V_{OL}	Output LOW Voltage (Note 5)	$V_{CCT} = 5.0\text{ V}$	3190	3380	3190	3380	3190	3380	mV
V_{BB}	Output Bias Voltage (Note 5)	$V_{CCT} = 5.0\text{ V}$	3600	3720	3600	3720	3600	3720	mV

NOTE: Device will meet the specifications after thermal equilibrium has been established when mounted in a test socket or printed circuit board with maintained transverse airflow greater than 500 lfm. Electrical parameters are guaranteed only over the declared operating temperature range. Functional operation of the device exceeding these conditions is not implied. Device specification limit values are applied individually under normal operating conditions and not valid simultaneously.

5. PECL V_{IL} , V_{IH} , V_{OL} , V_{OH} , V_{BB} are given for $V_{CCT} = V_{CCE} = 5.0\text{ V}$ and will vary 1:1 with the power supply.

Table 5. DC CHARACTERISTICS ($V_{CCT} = V_{CCE} = 5.0\text{ V} \pm 5\%$)

Symbol	Characteristic	Condition	$T_A = 0^\circ\text{C}$			$T_A = +25^\circ\text{C}$			$T_A = +85^\circ\text{C}$			Unit
			Min	Typ	Max	Min	Typ	Max	Min	Typ	Max	
I_{CCL}	Supply Current	Outputs LOW		18	30		18	30		18	30	mA
I_{CCH}	Supply Current	Outputs HIGH		13	25		13	25		13	25	mA
I_{GND}	Supply Current			75	90		75	90		75	95	mA

NOTE: Device will meet the specifications after thermal equilibrium has been established when mounted in a test socket or printed circuit board with maintained transverse airflow greater than 500 lfm. Electrical parameters are guaranteed only over the declared operating temperature range. Functional operation of the device exceeding these conditions is not implied. Device specification limit values are applied individually under normal operating conditions and not valid simultaneously.

MC10H606, MC100H606

Table 6. TTL DC CHARACTERISTICS ($V_{CCT} = V_{CCE} = 5.0\text{ V} \pm 5\%$)

Symbol	Characteristic	Condition	$T_A = 0^\circ\text{C}$		$T_A = 25^\circ\text{C}$		$T_A = 85^\circ\text{C}$		Unit
			Min	Max	Min	Max	Min	Max	
V_{IH}	Input HIGH Voltage		2.0		2.0		2.0		V
V_{IL}	Input LOW Voltage			0.8		0.8		0.8	V
V_{IK}	Input Clamp Voltage	$I_{IN} = -18\text{ mA}$		-1.2		-1.2		-1.2	V
I_{IH}	Input HIGH Current	$V_{IN} = 2.7\text{ V}$ $V_{IN} = 7.0\text{ V}$		20 100		20 100		20 100	V
I_{IL}	Input LOW Current	$V_{IN} = 0.5\text{ V}$		-0.6		-0.6		-0.6	mA

NOTE: Device will meet the specifications after thermal equilibrium has been established when mounted in a test socket or printed circuit board with maintained transverse airflow greater than 500 lfpm. Electrical parameters are guaranteed only over the declared operating temperature range. Functional operation of the device exceeding these conditions is not implied. Device specification limit values are applied individually under normal operating conditions and not valid simultaneously.

Table 7. AC CHARACTERISTICS ($V_{CCT} = V_{CCE} = 5.0\text{ V} \pm 5\%$)

Symbol	Characteristic	Condition	$T_A = 0^\circ\text{C}$			$T_A = +25^\circ\text{C}$			$T_A = +85^\circ\text{C}$			Unit
			Min	Typ	Max	Min	Typ	Max	Min	Typ	Max	
t_{PD}	Propagation Delay TCLK++	$50\ \Omega$ to $V_{CC}-2.0\text{ V}$	1.75		3.75	1.75	3.00	3.75	1.75		3.75	ns
t_{PD}	Propagation Delay TCLK+-	$50\ \Omega$ to $V_{CC}-2.0\text{ V}$	1.75		3.75	1.75	3.00	3.75	1.75		3.75	ns
t_{PD}	Propagation Delay CLK++	$50\ \Omega$ to $V_{CC}-2.0\text{ V}$	1.50		3.50	1.50	2.50	3.50	1.50		3.50	ns
t_{PD}	Propagation Delay CLK+-	$50\ \Omega$ to $V_{CC}-2.0\text{ V}$	1.50		3.50	1.50	2.50	3.50	1.50		3.50	ns
t_{PD}	Propagation Delay MR+-	$50\ \Omega$ to $V_{CC}-2.0\text{ V}$	1.50		3.50	1.50	2.50	3.50	1.75		3.75	ns
t_{SKEW}	Device Skew Part-to-Part Within Device	$50\ \Omega$ to $V_{CC}-2.0\text{ V}$			2.0 0.5		1.0 0.3	2.0 0.5			2.0 0.5	ns
t_S	Setup Time	$50\ \Omega$ to $V_{CC}-2.0\text{ V}$	1.5	0.5		1.5	0.5		1.5	0.5		ns
t_H	Hold Time	$50\ \Omega$ to $V_{CC}-2.0\text{ V}$	1.5	0.5		1.5	0.5		1.5	0.5		ns
t_{PW}	Minimum Pulse Width CLK	$50\ \Omega$ to $V_{CC}-2.0\text{ V}$	1.5			1.5	1.0		1.5			ns
t_{PW}	Minimum Pulse Width MR	$50\ \Omega$ to $V_{CC}-2.0\text{ V}$	1.5			1.5			1.5			ns
t_r	Rise Time	$50\ \Omega$ to $V_{CC}-2.0\text{ V}$			2.0		1.0	2.0			2.0	ns
t_f	Fall Time	$50\ \Omega$ to $V_{CC}-2.0\text{ V}$			2.0		1.0	2.0			2.0	ns
$t_{RES/REC}$	Reset/Recovery Time	$50\ \Omega$ to $V_{CC}-2.0\text{ V}$	2.5	2.0		2.5	2.0		2.5	2.0		ns

NOTE: Device will meet the specifications after thermal equilibrium has been established when mounted in a test socket or printed circuit board with maintained transverse airflow greater than 500 lfpm. Electrical parameters are guaranteed only over the declared operating temperature range. Functional operation of the device exceeding these conditions is not implied. Device specification limit values are applied individually under normal operating conditions and not valid simultaneously.

MC10H606, MC100H606

ORDERING INFORMATION

Device	Package	Shipping†
MC10H606FN	PLCC-28	37 Units / Rail
MC10H606FNG	PLCC-28 (Pb-Free)	37 Units / Rail
MC10H606FNR2	PLCC-28	500 / Tape & Reel
MC10H606FNR2G	PLCC-28 (Pb-Free)	500 / Tape & Reel
MC100H606FN	PLCC-28	37 Units / Rail
MC100H606FNG	PLCC-28 (Pb-Free)	37 Units / Rail

†For information on tape and reel specifications, including part orientation and tape sizes, please refer to our Tape and Reel Packaging Specifications Brochure, BRD8011/D.

Resource Reference of Application Notes

- AN1405/D** - ECL Clock Distribution Techniques
- AN1406/D** - Designing with PECL (ECL at +5.0 V)
- AN1503/D** - ECLinPS™ I/O SPiCE Modeling Kit
- AN1504/D** - Metastability and the ECLinPS Family
- AN1568/D** - Interfacing Between LVDS and ECL
- AN1672/D** - The ECL Translator Guide
- AND8001/D** - Odd Number Counters Design
- AND8002/D** - Marking and Date Codes
- AND8020/D** - Termination of ECL Logic Devices
- AND8066/D** - Interfacing with ECLinPS
- AND8090/D** - AC Characteristics of ECL Devices

MC10H606, MC100H606

PACKAGE DIMENSIONS

PLCC-28
FN SUFFIX
PLASTIC PLCC PACKAGE
CASE 776-02
ISSUE E

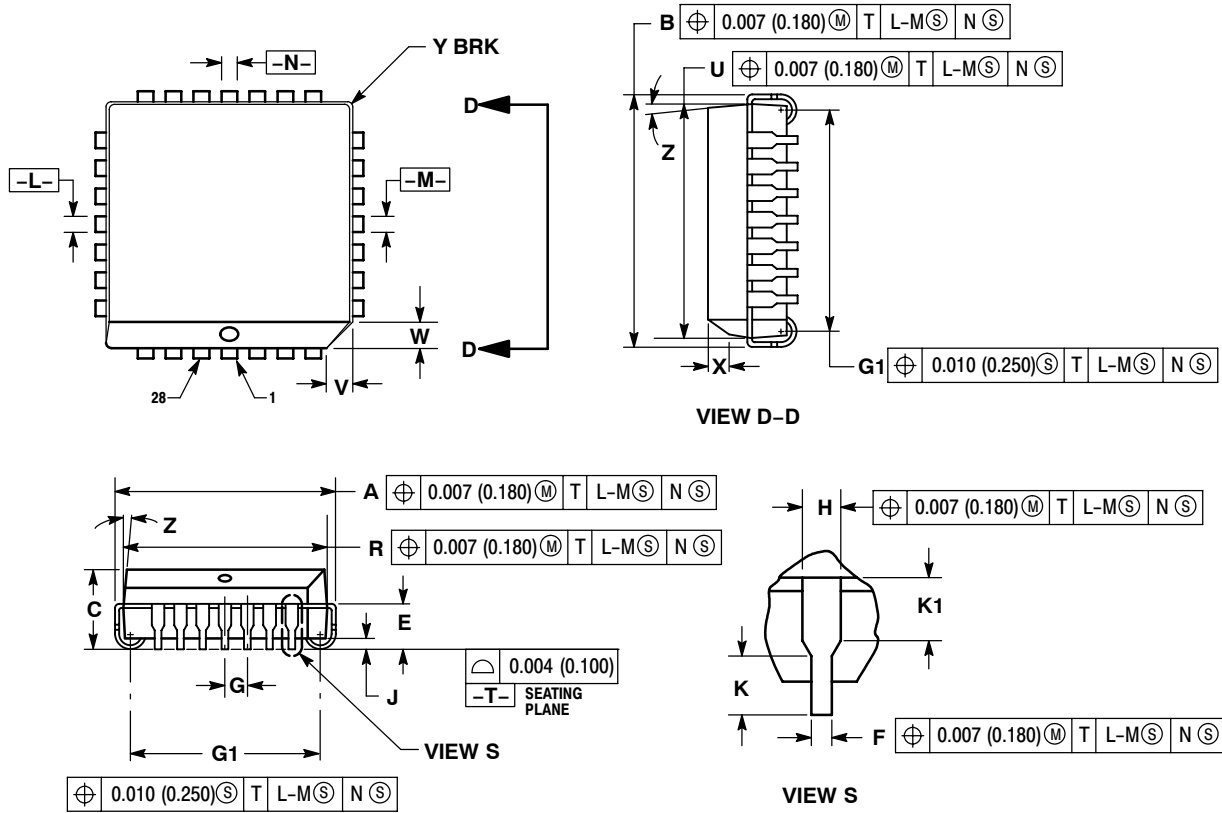

NOTES:

- DATUMS -L-, -M-, AND -N- DETERMINED WHERE TOP OF LEAD SHOULDER EXITS PLASTIC BODY AT MOLD PARTING LINE.
- DIMENSION G1, TRUE POSITION TO BE MEASURED AT DATUM -T-, SEATING PLANE.
- DIMENSIONS R AND U DO NOT INCLUDE MOLD FLASH. ALLOWABLE MOLD FLASH IS 0.010 (0.250) PER SIDE.
- DIMENSIONING AND TOLERANCING PER ANSI Y14.5M, 1982.
- CONTROLLING DIMENSION: INCH.
- THE PACKAGE BOTTOM MAY BE SMALLER THAN THE PACKAGE TOP BY UP TO 0.012 (0.300). DIMENSIONS R AND U ARE DETERMINED AT THE OUTERMOST EXTREMES OF THE PLASTIC BODY EXCLUSIVE OF MOLD FLASH, TIE BAR BURRS, GATE BURRS AND INTERLEAD FLASH, BUT INCLUDING ANY MISMATCH BETWEEN THE TOP AND BOTTOM OF THE PLASTIC BODY.
- DIMENSION H DOES NOT INCLUDE DAMBAR PROTRUSION OR INTRUSION. THE DAMBAR PROTRUSION(S) SHALL NOT CAUSE THE H DIMENSION TO BE GREATER THAN 0.037 (0.940). THE DAMBAR INTRUSION(S) SHALL NOT CAUSE THE H DIMENSION TO BE SMALLER THAN 0.025 (0.635).

DIM	INCHES		MILLIMETERS	
	MIN	MAX	MIN	MAX
A	0.485	0.495	12.32	12.57
B	0.485	0.495	12.32	12.57
C	0.165	0.180	4.20	4.57
E	0.090	0.110	2.29	2.79
F	0.013	0.019	0.33	0.48
G	0.050 BSC		1.27 BSC	
H	0.026	0.032	0.66	0.81
J	0.020	---	0.51	---
K	0.025	---	0.64	---
R	0.450	0.456	11.43	11.58
U	0.450	0.456	11.43	11.58
V	0.042	0.048	1.07	1.21
W	0.042	0.048	1.07	1.21
X	0.042	0.056	1.07	1.42
Y	---	0.020	---	0.50
Z	2°		10°	
G1	0.410	0.430	10.42	10.92
K1	0.040	---	1.02	---

MC10H606, MC100H606

ECLinPS is a trademark of Semiconductor Components Industries, LLC (SCILLC).
MECL 10 H is a trademark of Motorola, Inc.

ON Semiconductor and  are registered trademarks of Semiconductor Components Industries, LLC (SCILLC). SCILLC reserves the right to make changes without further notice to any products herein. SCILLC makes no warranty, representation or guarantee regarding the suitability of its products for any particular purpose, nor does SCILLC assume any liability arising out of the application or use of any product or circuit, and specifically disclaims any and all liability, including without limitation special, consequential or incidental damages. "Typical" parameters which may be provided in SCILLC data sheets and/or specifications can and do vary in different applications and actual performance may vary over time. All operating parameters, including "Typicals" must be validated for each customer application by customer's technical experts. SCILLC does not convey any license under its patent rights nor the rights of others. SCILLC products are not designed, intended, or authorized for use as components in systems intended for surgical implant into the body, or other applications intended to support or sustain life, or for any other application in which the failure of the SCILLC product could create a situation where personal injury or death may occur. Should Buyer purchase or use SCILLC products for any such unintended or unauthorized application, Buyer shall indemnify and hold SCILLC and its officers, employees, subsidiaries, affiliates, and distributors harmless against all claims, costs, damages, and expenses, and reasonable attorney fees arising out of, directly or indirectly, any claim of personal injury or death associated with such unintended or unauthorized use, even if such claim alleges that SCILLC was negligent regarding the design or manufacture of the part. SCILLC is an Equal Opportunity/Affirmative Action Employer. This literature is subject to all applicable copyright laws and is not for resale in any manner.

PUBLICATION ORDERING INFORMATION

LITERATURE FULFILLMENT:

Literature Distribution Center for ON Semiconductor
P.O. Box 5163, Denver, Colorado 80217 USA
Phone: 303-675-2175 or 800-344-3860 Toll Free USA/Canada
Fax: 303-675-2176 or 800-344-3867 Toll Free USA/Canada
Email: orderlit@onsemi.com

N. American Technical Support: 800-282-9855 Toll Free
USA/Canada
Europe, Middle East and Africa Technical Support:
Phone: 421 33 790 2910
Japan Customer Focus Center
Phone: 81-3-5773-3850

ON Semiconductor Website: www.onsemi.com
Order Literature: <http://www.onsemi.com/orderlit>
For additional information, please contact your local
Sales Representative

Looking for pricing, stock, or lifecycle information?

Click below to explore more details on WIN SOURCE:

 [View MC10H606FNR2 on WIN SOURCE](#)

 [ON Semiconductor](#) Information

Optimize Your Supply Chain with WIN SOURCE Solutions

-  Global Sourcing Solution
-  Obsolete Management
-  Cost Control Management
-  Shortage Management
-  Alternative Solution
-  Excess Inventory Management