



**THE DATASHEET OF
MC33287DW**



Contact Monitoring and Dual Low-Side Protected Driver

The 33287 interfaces between switch contacts and a microcontroller. Eight switch-to-battery (or switch-to-ground) sense monitor switch status. Additionally, two internal low-side switches are available to control inductive or capacitive loads.

The 33287 has eight sense inputs (rated at 40 V) with thresholds ratiometric to V_{BAT} . One sense input has a dedicated output for direct interfacing to the MCU and the remaining seven inputs are multiplexed interfaced to the MCU.

The two low-side switch outputs are current limited to 535 mA and internally clamped to 50 V. Outputs also have independent overtemperature shutdown and diagnostic reporting.

Features

- Eight High-Voltage Sense Inputs
- Direct Interfacing to Microcontroller
- Two Current Limited Low-Side Drivers
- Drivers Internally Overvoltage Clamped and Thermally Protected
- 55 μ A Standby Current
- Pb-Free Packaging Designated by Suffix Code EG

33287

AUTOMOTIVE CONTACT MONITORING AND DUAL LOW-SIDE PROTECTED DRIVER



ORDERING INFORMATION		
Device	Temperature Range (T_A)	Package
MC33287DW/R2	-40 to 125°C	20 SOICW
MCZ33287EG/R2		

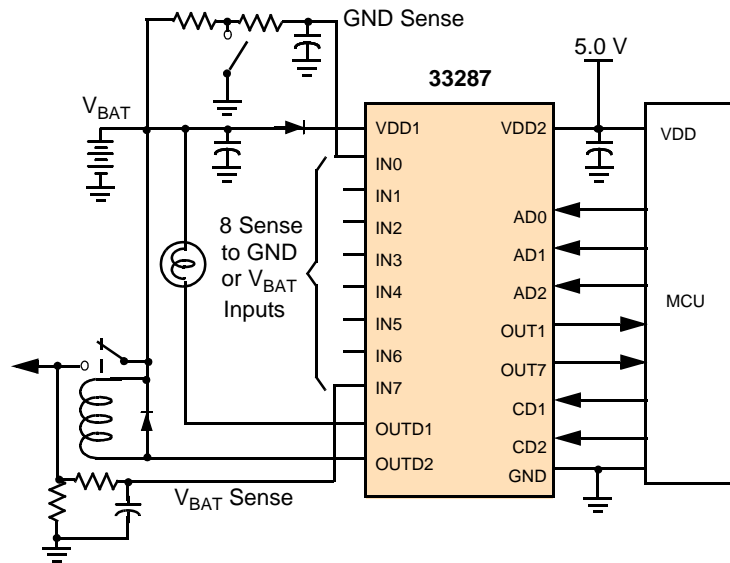

Figure 1. Simplified Application Design

INTERNAL BLOCK DIAGRAM

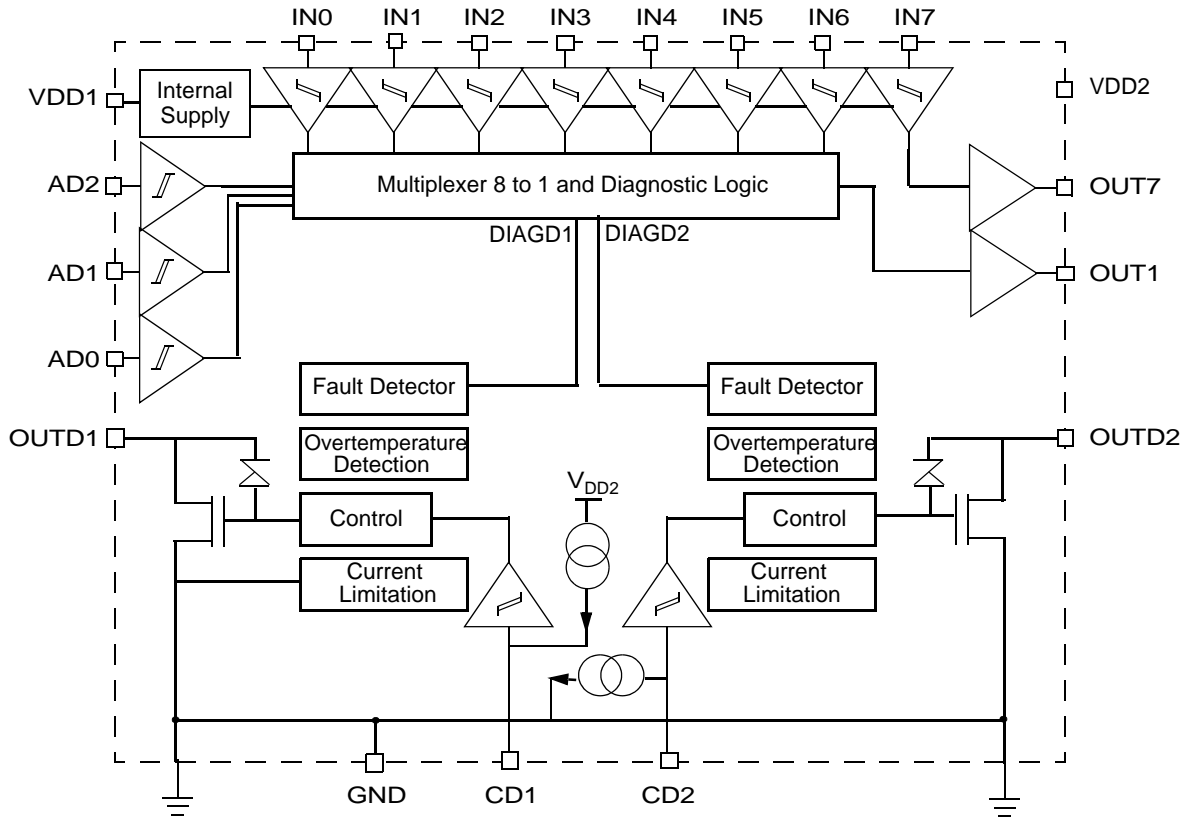

Figure 2. 33287 Simplified Internal Block Diagram

PIN CONNECTIONS

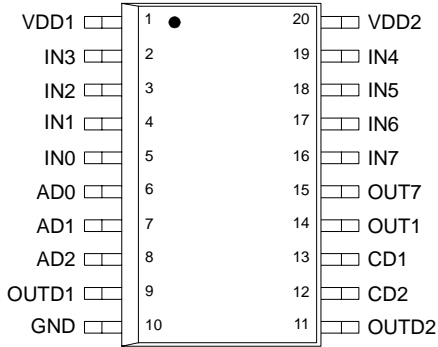

Figure 3. 33287 Pin Connections

Table 1. 33287 Pin Definitions

Pin Number	Pin Name	Formal Name	Definition
1, 20	V _{DD1} , V _{DD2}	Voltage Power	These are high-voltage power supply 5.0 V pins (V _{BAT}).
5, 4, 3, 2, 19, 18, 17, 16	IN0 – IN7	Input 0 – 7	These are high-voltage input pins.
6, 7, 8	AD0 – AD2	Address	These pins are the addresses for mode and input selection.
9, 11	OUTD1, OUTD2	Output Drain	These two are output driver pins (drain).
10	GND	Ground	This pin is the ground for the logic and analog circuitry of the device.
12, 13	CD1, CD2	Command Driver	These are the two driver command pins.
14	OUT1	Output 1	This is the output (multiplexed Output 1 = 0 to 6.0 V for IN0 to IN6 and DIAGD1 or DIAGD2) and DIAGD2 pins.
15	OUT7	Output 7	This is the direct output from IN7 pin.



ELECTRICAL CHARACTERISTICS

MAXIMUM RATINGS

Table 2. MAXIMUM RATINGS

All voltages are with respect to ground unless otherwise noted.

Rating	Symbol	Value	Unit
Power Supply Voltage Normal Operation (Steady-State) Load Dump Conditions	V_{DD1}	24 40	V
Logic Supply Voltage (Continuous)	V_{DD2}	7.0	V
Input Pin Voltage ⁽¹⁾	V_{IN}	40	V
ESD Voltage ⁽²⁾ Human Body Model Machine Model	V_{ESD1} V_{ESD2}	±2000 ±200	V
Operating Ambient Temperature	T_A	-40 to 125°C	°C
Storage Temperature	T_{STG}	-65 to 150	°C
Power Dissipation ($T_A = 85^\circ\text{C}$)	P_D	0.7	W
Peak Package Reflow Temperature During Reflow ^{(3), (4)}	T_{PPRT}	Note 4.	°C
Thermal Resistance Junction-to-Ambient	$R\theta_{J-A}$	100	°C/W

Notes

- 1 With Serial Resistor $\geq 25 \text{ k}\Omega$
- 2 ESD1 testing is performed in accordance with the Human Body Model ($C_{ZAP}=100 \text{ pF}$, $R_{ZAP}=1500 \Omega$), ESD2 testing is performed in accordance with the Machine Model ($C_{ZAP}=200 \text{ pF}$, $R_{ZAP}=0 \Omega$).
3. Pin soldering temperature limit is for 10 seconds maximum duration. Not designed for immersion soldering. Exceeding these limits may cause malfunction or permanent damage to the device.
4. Freescale's Package Reflow capability meets Pb-free requirements for JEDEC standard J-STD-020C. For Peak Package Reflow Temperature and Moisture Sensitivity Levels (MSL), Go to www.freescale.com, search by part number [e.g. remove prefixes/suffixes and enter the core ID to view all orderable parts. (i.e. MC33xxx enter 33xxx), and review parametrics.

STATIC ELECTRICAL CHARACTERISTICS

Table 3. STATIC ELECTRICAL CHARACTERISTICS

Characteristics noted under conditions $7.0\text{ V} \leq V_{DD1} \leq 18\text{ V}$, $4.75\text{ V} \leq V_{DD2} \leq 5.25\text{ V}$, $-40^\circ\text{C} \leq T_A \leq 125^\circ\text{C}$, unless otherwise noted. Extended limit is $5.0\text{ V} \leq V_{DD1} \leq 7.0\text{ V}$ and other parameters are full specification in this mode. Inputs IN1–IN7 and low-side drivers are still functional with down-graded characteristics.

Characteristic	Symbol	Min	Typ	Max	Unit
SUPPLY VOLTAGE (V_{DD1} AND V_{DD2} PINS)					
Operational Supply Voltage	VDD1	7.0	12	18	V
Full Specification					
Extend Limit		5.0	—	7.0	
Operational Supply Voltage (Full Specification)	VDD2	4.75	—	—	V
Supply Current Standby Mode ⁽⁵⁾					μA
$V_{DD1} \leq 14\text{ V}$	IVDD1-0	—	55	110	
$V_{CD1} = V_{DD2}$, $V_{CD2} = 0\text{ V}$	IVDD2-0	—	—	10	
Supply Current in Drivers on Configuration (Full Specification) ⁽⁵⁾					μA
$V_{CD1} = 0\text{ V}$	IVDD1-1	—	250	1500	
$V_{CD2} = V_{DD2}$	IVDD2-1	—	650	1500	
OUTPUT DRIVERS CHARACTERISTICS (OUTD1 AND OUTD2 PINS)					
Output Resistance (Full Specification and $T_J \leq 130^\circ\text{C}$)	R _{DS(ON)}	—	1.40	3.20	Ω
Output Resistance (Extent Limit and $T_J \leq 130^\circ\text{C}$)	R _{DS(ON)}	—	—	5.0	Ω
Leakage Current (Internal Current Source)	I _{LEAK}	1.0	—	13	μs
PROTECTION AND LEVEL DETECTION (OUTD1 AND OUTD2 PINS)					
Positive Output Clamp	V _{CLAMP}	40	50	60	V
Output Current Limitation ($130^\circ\text{C} \geq T_J$)	I _{LIM}	300	535	750	mA
Output Fault Detector Level	V _{FAULT}	2.0	2.75	3.5	V
Overtemperature Detection (at 25°C by Function Simulation)	T _{DETEC}	145	160	175	$^\circ\text{C}$
INPUTS (CD1 AND CD2 PINS)					
Input Voltage Low	V _{IL}	—	—	$4.0 \times V_{DD2}$	V
Input Voltage High	V _{IH}	$8.0 \times V_{DD2}$	—	—	V
Hysteresis	V _{HST}	500	800	—	mV
Input Current on Pin CD1 (Internal Pull-Up and CD1 Connected to Ground)	I _{CD1}	-100	-30	-10	μA
Leakage Current on Pin CD1 (Internal Pull-Up Connected to V_{DD2})	I _{LEAK}	-5.0	—	5.0	μA
Input Current on Pin CD2 (Internal Pull Down CD2 Connected to V_{DD2})	I _{CD2}	10	30	100	μA
Leakage Current on Pin CD2 (Internal Pull-Up CD1 Connected to Ground)	I _{LEAK}	-5.0	—	5.0	μA

Notes

- 5 All INn and ADn inputs are connected to ground.

Table 3. STATIC ELECTRICAL CHARACTERISTICS (continued)

Characteristics noted under conditions $7.0\text{ V} \leq V_{DD1} \leq 18\text{ V}$, $4.75\text{ V} \leq V_{DD2} \leq 5.25\text{ V}$, $-40^\circ\text{C} \leq T_A \leq 125^\circ\text{C}$, unless otherwise noted. Extended limit is $5.0\text{ V} \leq V_{DD1} \leq 7.0\text{ V}$ and other parameters are full specification in this mode. Inputs IN1–IN7 and low-side drivers are still functional with down-graded characteristics.

Characteristic	Symbol	Min	Typ	Max	Unit
INPUTS (IN0 TO IN7 PINS)					
Input Voltage Low (Full Specification)	V_{IL}	—	—	$4.0 \times V_{DD1}$	V
Input Voltage Low (Extended Limit)	V_{IL}	—	—	$3.0 \times V_{DD1}$	V
Input Voltage High (Full Specification and Extended Limit)	V_{IH}	$7.0 \times V_{DD1}$	—	—	V
Hysteresis ($5.0\text{ V} < V_{DD1} < 16\text{ V}$)	V_{HYS}	5.0	1.0	—	V
Input Current ($V_{IN} < 16\text{ V}$)	I_{LEAK}	5.0	—	5.0	μA
Input Voltage Clamp ($I = 100\ \mu\text{A}$)	$V_{INCLAMP}$	17	20	23	V
INPUTS (AD0, AD1, AND AD2 PINS)					
Input Voltage Low	V_{IL}	—	—	$4.0 \times V_{DD2}$	V
Input Voltage High	V_{IH}	$8.0 \times V_{DD2}$	—	—	V
Hysteresis	V_{HYS}	500	750	—	mV
Input Current	I_{LEAK}	-5.0	—	5.0	μA
OUTPUTS (OUT1 AND OUT7 PINS)					
Output Voltage Low ($I_{LOAD} = 2.0\text{ mA}$)	V_{OL}	—	—	$2.0 \times V_{DD2}$	V
Output Voltage High ($I_{LOAD} = -2.0\text{ mA}$)	V_{OH}	$8.0 \times V_{DD2}$	—	—	V

DYNAMIC ELECTRICAL CHARACTERISTICS

Table 4. DYNAMIC ELECTRICAL CHARACTERISTICS

Characteristics noted under conditions $4.5\text{ V} \leq V_{DD} \leq 5.5\text{ V}$, $9.0\text{ V} \leq V_{PWR} \leq 16\text{ V}$, $-40^\circ\text{C} \leq T_A \leq 125^\circ\text{C}$, unless otherwise noted. Typical values noted reflect the approximate parameter mean at $T_A = 25^\circ\text{C}$ under nominal conditions, unless otherwise noted.

Characteristic	Symbol	Min	Typ	Max	Unit
OUTPUT DRIVERS CHARACTERISTICS (OUTD1 AND OUTD2 PINS)					
Turn ON Delay Time	t_{ON}	—	1.3	10	μs
Turn OFF Delay Time	t_{OFF}	—	2.1	10	μs
Output Rising Edge	t_{RISE}	—	2.8	10	μs
Output Falling Edge	t_{FALL}	—	1.0	10	μs
Difference Between Command Duration and Bit Duration	Δ_{BIT}	-5.0	—	5.0	μs

TIMING DIAGRAMS

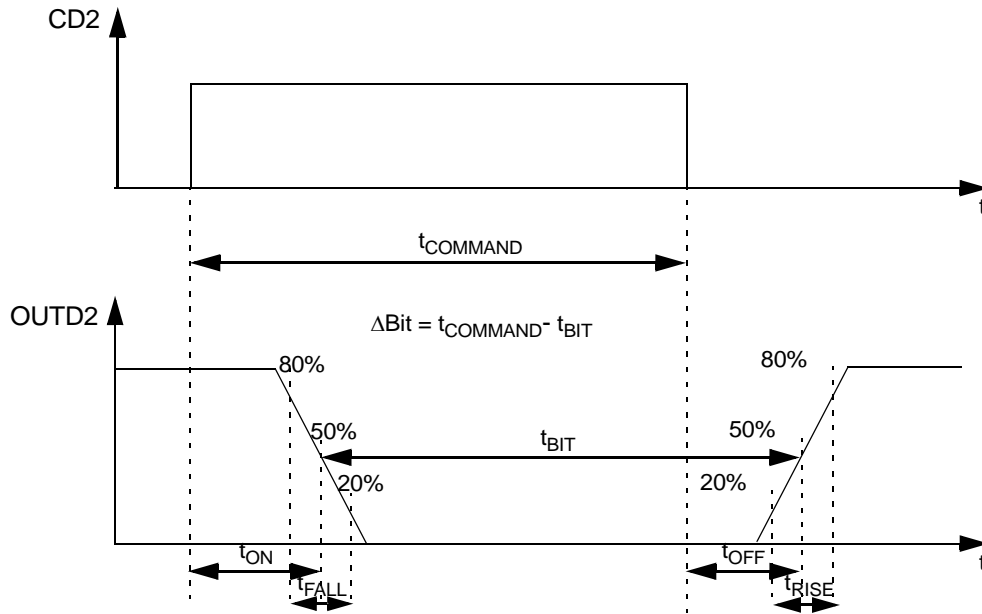

Figure 4. Timing Characteristics

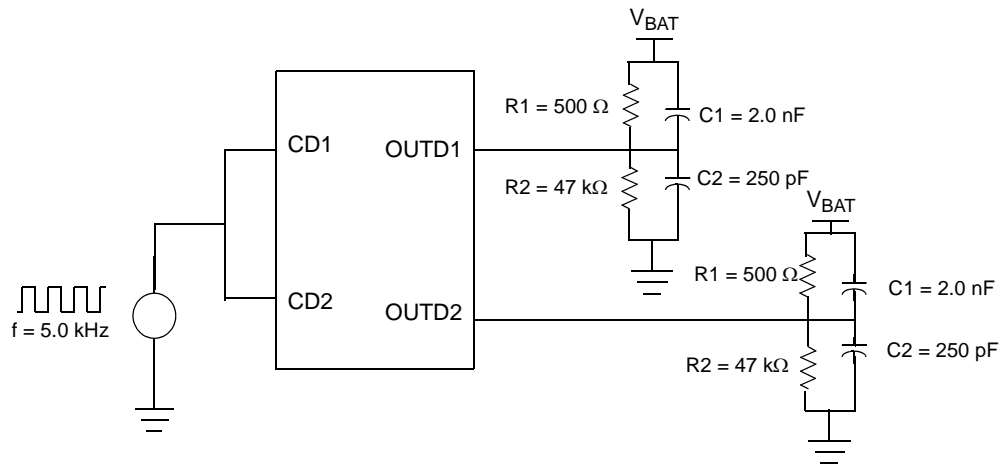

Figure 5. Timing Test Configuration

FUNCTIONAL DEVICE OPERATION

LOGIC COMMANDS AND REGISTERS

Table 5. Drivers Function Table

CD1 ⁽⁶⁾	OUTD1	DIAGD1 ⁽⁸⁾	Status
High Level for Logic Signals	High Level for Drivers Outputs	High Level for Logic Signals	Driver 1 Normally OFF
Low Level for Logic Signals	Low Level for Drivers Outputs	High Level for Logic Signals	Driver 1 Normally ON
High Level for Logic Signals	Low Level for Drivers Outputs	Low Level for Logic Signals	Driver 1 Shorted to GND or Open Load
Low Level for Logic Signals	High Level for Drivers Outputs	Low Level for Logic Signals	Driver 1 Overloaded
CD2 ⁽⁷⁾	OUTD2	DIAGD2	Status
Low Level for Logic Signals	High Level for Drivers Outputs	High Level for Logic Signals	Driver 2 Normally OFF
High Level for Logic Signals	Low Level for Drivers Outputs	High Level for Logic Signals	Driver 2 Normally ON
Low Level for Logic Signals	Low Level for Drivers Outputs	Low Level for Logic Signals	Driver 2 Shorted to GND or Open Load
High Level for Logic Signals	High Level for Drivers Outputs	Low Level for Logic Signals	Driver 2 Overloaded

Notes

- 6 CD1 is active on low level (driver 1 is on when CD1 is low).
- 7 CD2 is active on high level (driver 2 is on when CD2 is high).
- 8 DIAGD1 output is neither latched nor filtered.

Table 6. Eight-to-One Data Multiplexer Function

Inputs			OUT1
AD2	AD1	AD0	
High Impedance	High Impedance	High Impedance	Unknown
Low Level	Low Level	Low Level	IN0 ⁽⁹⁾
Low Level	Low Level	High Level	IN1
Low Level	High Level	Low Level	IN2
Low Level	High Level	High Level	IN3
High Level	Low Level	Low Level	IN4
High Level	Low Level	High Level	IN5
High Level	High Level	Low Level	IN6
High Level	High Level	High Level	DIAGD1 or DIAGD2 ⁽¹⁰⁾

Notes

- 9 IN0 to IN6 are the normalized values.
- 10 DIAGD1 or DIAGD2 are the values of the selected internal fault detector. See [Table 7](#).

Table 7. Fault Detector Selection

Inputs			OUT1
AD2	AD1	AD0	
Unknown	Unknown	Unknown	Unknown
Unknown	Low Level	High Level	Unknown
High Level	High Level	High Level	DIAGD1
Unknown	Unknown	Unknown	Unknown
Unknown	High Level	Low Level	Unknown
High Level	High Level	High Level	DIAGD2

TYPICAL APPLICATIONS

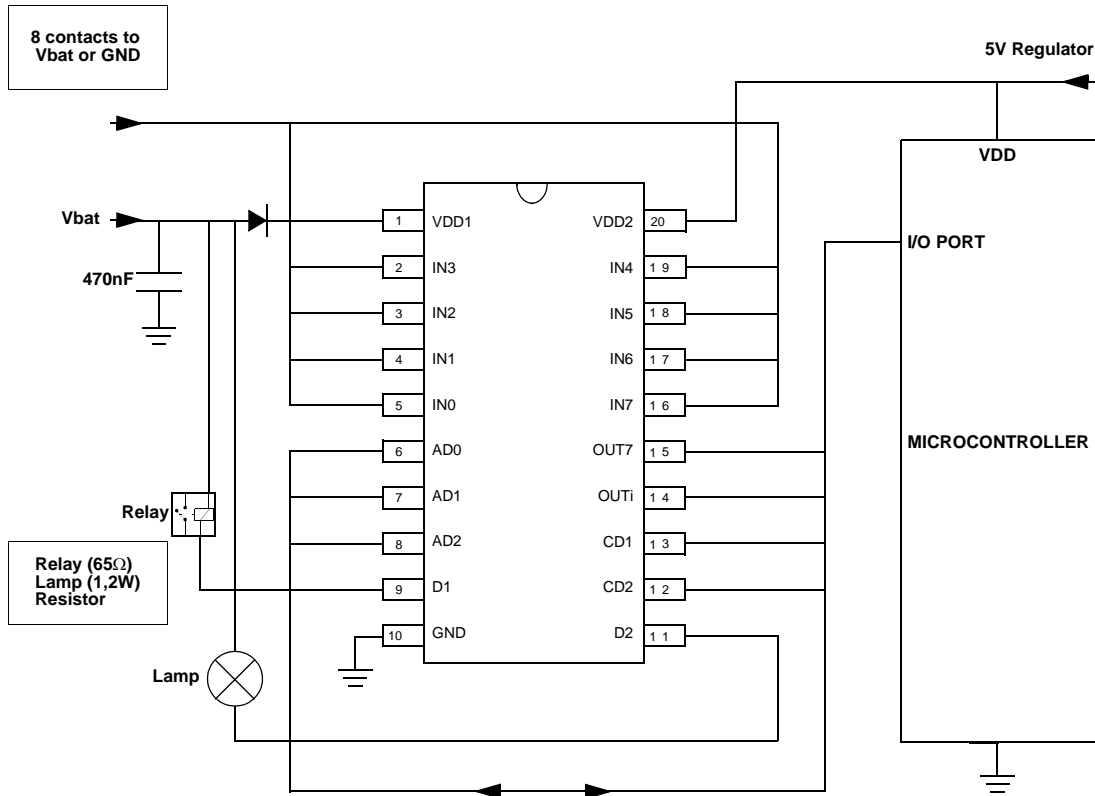

Figure 6. Typical Application Configuration

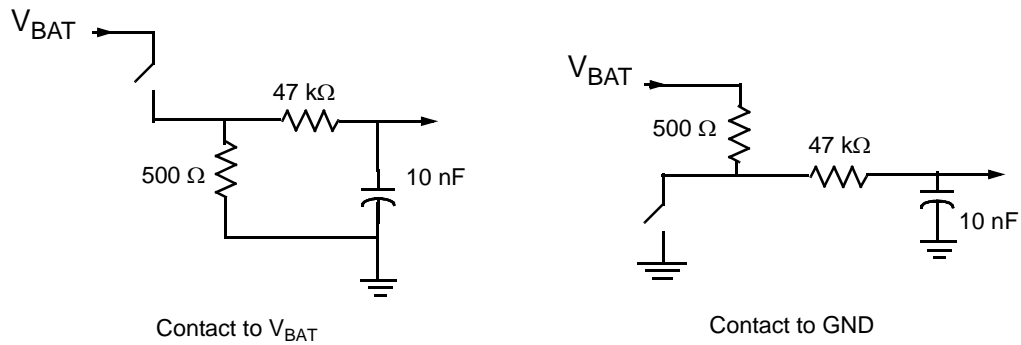
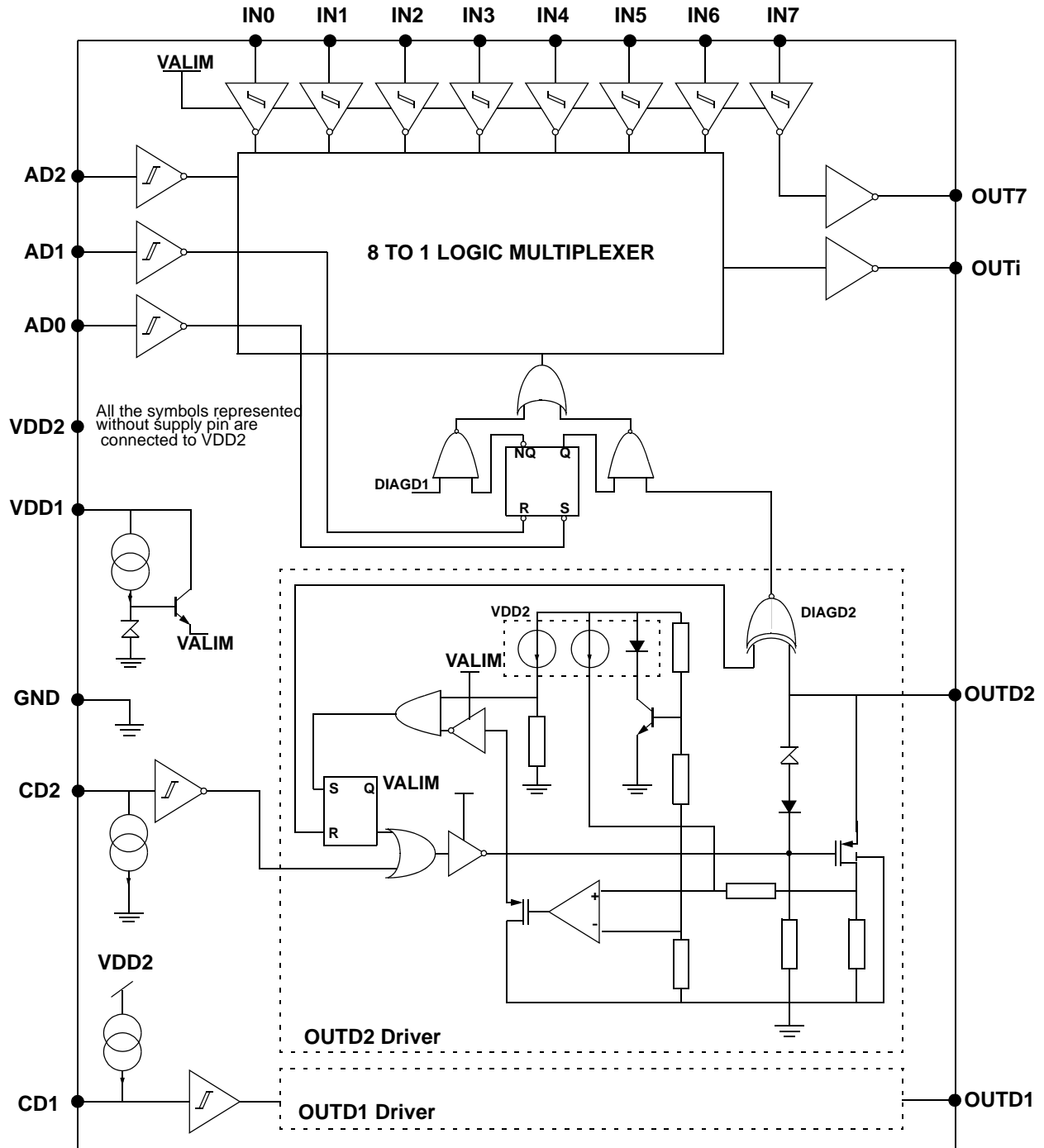

Figure 7. Contact Configuration



NOTE: The only difference between the low side driver 1 and 2 is the polarity of the command. Also, there is an integral pull-up at pin CD1, and an internal pull-down at pin CD2.

Figure 8. Electrical Schematic

PACKAGE

PACKAGE DIMENSIONS

For the most current package revision, visit www.freescale.com and perform a keyword search using the "98A" listed below.

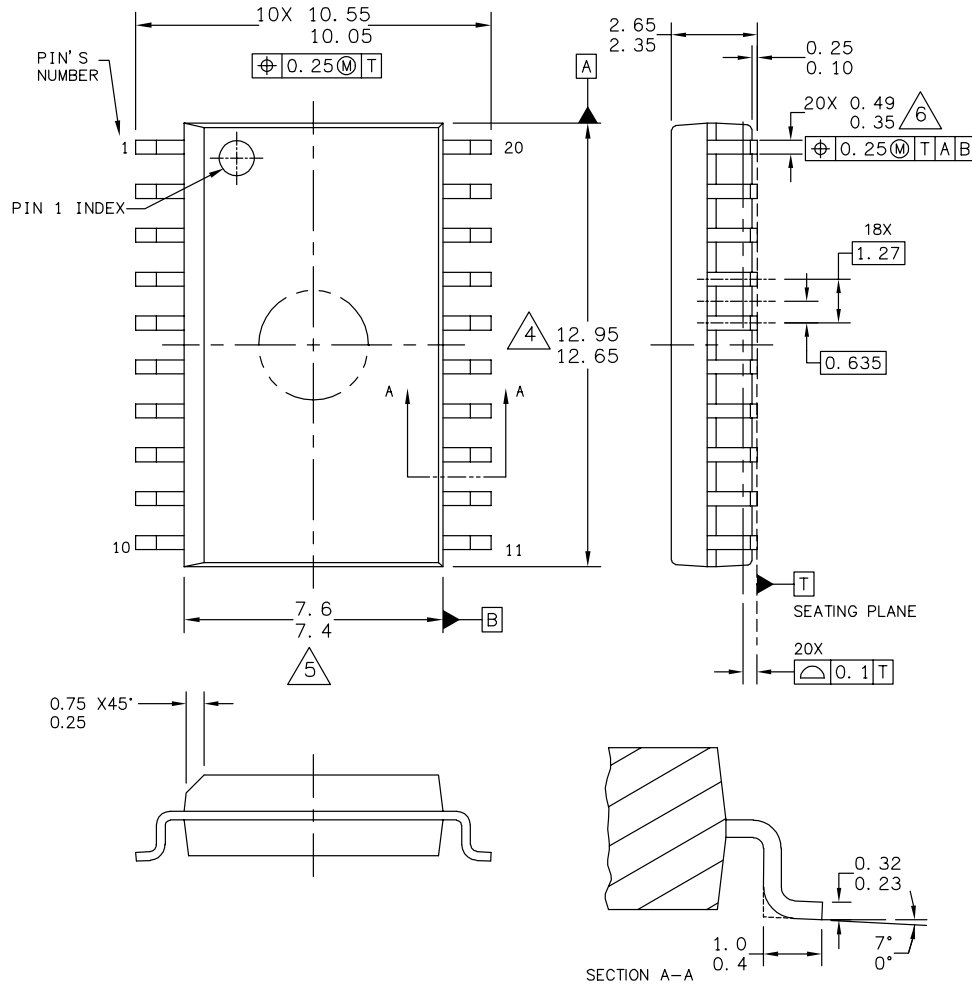

© FREESCALE SEMICONDUCTOR, INC. ALL RIGHTS RESERVED.	MECHANICAL OUTLINE	PRINT VERSION NOT TO SCALE
TITLE: 20LD SOIC W/B, 1.27 PITCH CASE-OUTLINE	DOCUMENT NO: 98ASB42343B	REV: J
	CASE NUMBER: 751D-07	23 MAR 2005
	STANDARD: JEDEC MS-013AC	

DW SUFFIX
EG SUFFIX (PB-FREE)
20-PIN
PLASTIC PACKAGE
98ASB42343B
REV. J

REVISION HISTORY

REVISION	DATE	DESCRIPTION OF CHANGES
4.0	11/2006	<ul style="list-style-type: none"> • Converted to Freescale format with the current form and style • Implemented Revision History page • Updated Package Drawing 98ASB42343B to Rev. J • Added EG Pb-FREE suffix • Removed Peak Package Reflow Temperature During Reflow (solder reflow) parameter from Maximum Ratings on page 4. Added note with instructions to obtain this information from www.freescale.com.
5.0	2/2007	<ul style="list-style-type: none"> • Corrected Internal Block Diagram on page 2 • Restated Definition for OUT1 in 33287 Pin Definitions on page 3 • Corrected value for Storage Temperature on page 4 • Corrected unit for Output Resistance (Extent Limit and $T_J \leq 130^\circ\text{C}$) on page 5 • Corrected Electrical Schematic on page 12 • Restated note 4 in Maximum Ratings on page 4.

How to Reach Us:

Home Page:

www.freescale.com

E-mail:

support@freescale.com

USA/Europe or Locations Not Listed:

Freescale Semiconductor
Technical Information Center, CH370
1300 N. Alma School Road
Chandler, Arizona 85224
+1-800-521-6274 or +1-480-768-2130
www.freescale.com/support

Europe, Middle East, and Africa:

Freescale Halbleiter Deutschland GmbH
Technical Information Center
Schatzbogen 7
81829 Muenchen, Germany
+44 1296 380 456 (English)
+46 8 52200080 (English)
+49 89 92103 559 (German)
+33 1 69 35 48 48 (French)
support@freescale.com

Japan:

Freescale Semiconductor Japan Ltd.
Headquarters
ARCO Tower 15F
1-8-1, Shimo-Meguro, Meguro-ku,
Tokyo 153-0064
Japan
0120 191014 or +81 3 5437 9125
support.japan@freescale.com

Asia/Pacific:

Freescale Semiconductor Hong Kong Ltd.
Technical Information Center
2 Dai King Street
Tai Po Industrial Estate
Tai Po, N.T., Hong Kong
+800 2666 8080
support.asia@freescale.com

For Literature Requests Only:

Freescale Semiconductor Literature Distribution Center
P.O. Box 5405
Denver, Colorado 80217
1-800-441-2447 or 303-675-2140
Fax: 303-675-2150
LDCForFreescaleSemiconductor@hibbertgroup.com

RoHS-compliant and/or Pb-free versions of Freescale products have the functionality and electrical characteristics of their non-RoHS-compliant and/or non-Pb-free counterparts. For further information, see <http://www.freescale.com> or contact your Freescale sales representative.

For information on Freescale's Environmental Products program, go to <http://www.freescale.com/epp>.

Information in this document is provided solely to enable system and software implementers to use Freescale Semiconductor products. There are no express or implied copyright licenses granted hereunder to design or fabricate any integrated circuits or integrated circuits based on the information in this document.

Freescale Semiconductor reserves the right to make changes without further notice to any products herein. Freescale Semiconductor makes no warranty, representation or guarantee regarding the suitability of its products for any particular purpose, nor does Freescale Semiconductor assume any liability arising out of the application or use of any product or circuit, and specifically disclaims any and all liability, including without limitation consequential or incidental damages. "Typical" parameters that may be provided in Freescale Semiconductor data sheets and/or specifications can and do vary in different applications and actual performance may vary over time. All operating parameters, including "Typicals", must be validated for each customer application by customer's technical experts. Freescale Semiconductor does not convey any license under its patent rights nor the rights of others. Freescale Semiconductor products are not designed, intended, or authorized for use as components in systems intended for surgical implant into the body, or other applications intended to support or sustain life, or for any other application in which the failure of the Freescale Semiconductor product could create a situation where personal injury or death may occur. Should Buyer purchase or use Freescale Semiconductor products for any such unintended or unauthorized application, Buyer shall indemnify and hold Freescale Semiconductor and its officers, employees, subsidiaries, affiliates, and distributors harmless against all claims, costs, damages, and expenses, and reasonable attorney fees arising out of, directly or indirectly, any claim of personal injury or death associated with such unintended or unauthorized use, even if such claim alleges that Freescale Semiconductor was negligent regarding the design or manufacture of the part.

Freescale™ and the Freescale logo are trademarks of Freescale Semiconductor, Inc. All other product or service names are the property of their respective owners.

© Freescale Semiconductor, Inc., 2007. All rights reserved.

Looking for pricing, stock, or lifecycle information?

Click below to explore more details on WIN SOURCE:

- ⊖ [View MC33287DW on WIN SOURCE](#)
- ⊖ [Freescale Semiconductor - NXP Information](#)

Optimize Your Supply Chain with WIN SOURCE Solutions

- ✓ Global Sourcing Solution
- ✓ Obsolete Management
- ✓ Cost Control Management
- ✓ Shortage Management
- ✓ Alternative Solution
- ✓ Excess Inventory Management