



**THE DATASHEET OF
MC56F8014VFAE**



56F8014

Data Sheet

Technical Data

56F8000
16-bit Digital Signal Controllers

MC56F8014
Rev. 11
05/2008

freescale.com

Document Revision History

Version History	Description of Change
Rev 0	Initial release
Rev 1	Updates to Part 10, Specifications , Table 10-1 , added maximum clamp current, per pin Table 10-11 , clarified variation over temperature table and graph Table 10-15 , added LIN slave timing
Rev 2	Added alternate pins to Figure 11-1 and Table 11-1 .
Rev 3	Corrected bit selects in Timer Channel 3 Input (TC3_INP) bit 9, Section 6.3.1.7 , clarified Section 1.4.1 , and simplified notes in Table 10-9 ,
Rev 4	Added clarification on sync inputs in Section 1.4.1 , added voltage difference specification to Table 10-1 and Table 10-4 , deleted formula for Ambient Operating Temperature in Table 10-4 , and a note for pin group 3, corrected Table 8-1 , error in Port C peripheral function configuration, updated notes in Table 10-9 . Added RoHs and “pb-free” language to back cover.
Rev 5	Updates to Section 10 Table 10-5 , corrected max values for ADC Input Current High and Low; corrected typ value for pull-up disabled Digital Input Current Low (a) Table 10-6 , corrected typ and added max values for Standby > Stop and Powerdown modes Table 10-7 , corrected min value for Low-Voltage Interrupt for 3.3V Table 10-11 , corrected typ and max values and units for PLL lock time Table 10-12 , corrected typ values for Relaxation Oscillator output frequency and variation over temperature (also increased temp range to 150 degreesC) and added variation over temperature from 0—105 degreesC Updated Figure 10-5 Table 10-19 , updated max values for Integral Non-Linearity full input signal range, Negative Differential Non-Linearity, ADC internal clock, Offset Voltage Internal Ref, Gain Error and Offset Voltage External Ref; updated typ values for Negative Differential Non-Linearity, Offset Voltage Internal Ref, Gain Error and Offset Voltage External Ref; added new min values and corrected typ values for Signal-to-noise ratio, Total Harmonic Distortion, Spurious Free Dynamic Range, Signal-to-noise plus distortion, Effective Number of Bits
Rev 6	Added details to Section 1. Clarified language in State During Reset column in Table 2-3 ; corrected flash data retention temperature in Table 10-4 ; moved input current high/low to Table 10-19 and location of footnotes in Table 10-5 ; reorganized Table 10-19 ; clarified title of Figure 10-1 .
Rev. 7	<ul style="list-style-type: none"> • In Table 10-4, added an entry for flash data retention with less than 100 program/erase cycles (minimum 20 years). • In Table 10-6, changed the device clock speed in STOP mode from 8MHz to 4MHz. • In Table 10-12, changed the typical relaxation oscillator output frequency in Standby mode from 400kHz to 200kHz.
Rev. 8	In Table 10-19 , changed the maximum ADC internal clock frequency from 8MHz to 5.33MHz.

Document Revision History (Continued)

Version History	Description of Change
Rev. 9	Added the following note to the description of the TMS signal in Table 2-3 : Note: Always tie the TMS pin to V _{DD} through a 2.2K resistor.
Rev. 10	<ul style="list-style-type: none"> • In Table 2-3, changed V_{CAP} value from 4.7 μF to 2.2 μF. • In Table 2-3, changed the input type for FAULT3 (was “Output”, is “Input”). • In Table 2-3, changed the input type for FAULT2 (was “Input/Output”, is “Input”). • Revised Section 7, Security Features. • Added MC56F8014MFAE to Section 13, Ordering Information. • Fixed miscellaneous errors.
Rev.11	<ul style="list-style-type: none"> • Updated temperature information in Table 10-1 and Table 10-4.

Please see <http://www.freescale.com> for the most current data sheet revision.

56F8014 General Description

- Up to 32 MIPS at 32MHz core frequency
- DSP and MCU functionality in a unified, C-efficient architecture
- 16KB Program Flash
- 4KB Unified Data/Program RAM
- One 5-channel PWM module
- Two 4-channel 12-bit ADCs
- One Serial Communication Interface (SCI) with LIN slave functionality
- One Serial Peripheral Interface (SPI)
- One 16-bit Quad Timer
- One Inter-Integrated Circuit (I²C) Port
- Computer Operating Properly (COP)/Watchdog
- On-Chip Relaxation Oscillator
- Integrated Power-On Reset and Low-Voltage Interrupt Module
- JTAG/Enhanced On-Chip Emulation (OnCE™) for unobtrusive, real-time debugging
- Up to 26 GPIO lines
- 32-pin LQFP Package

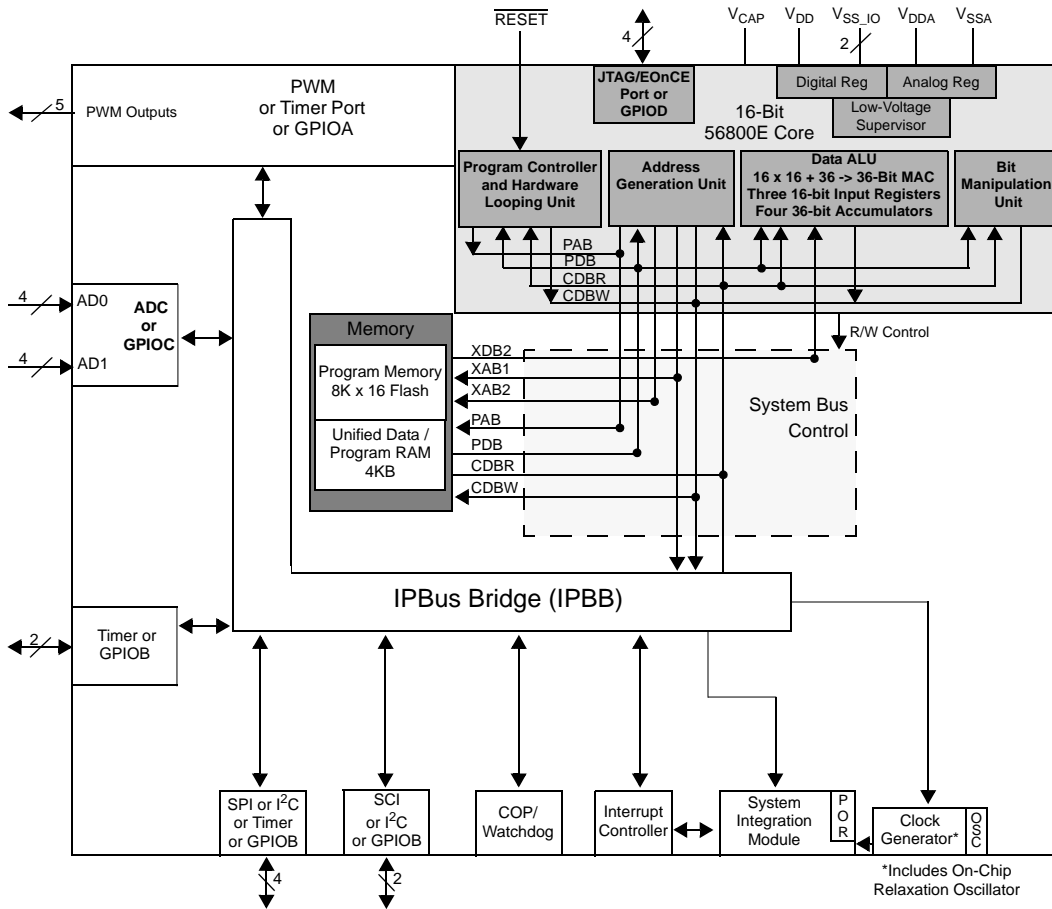

56F8014 Block Diagram

56F8014 Data Sheet Table of Contents

Part 1: Overview	6	Part 7: Security Features	82
1.1. 56F8014 Features	6	7.1. Operation with Security Enabled	82
1.2. 56F8014 Description	8	7.2. Flash Access Lock and Unlock Mechanisms	83
1.3. Award-Winning Development Environment	8	7.3. Product Analysis	84
1.4. Architecture Block Diagram	9	Part 8: General Purpose Input/Output (GPIO)	
1.5. Synchronize ADC with PWM	9	84
1.6. Multiple Frequency PWM Output	9	8.1. Introduction	84
1.7. Product Documentation	13	8.2. Configuration	84
1.8. Data Sheet Conventions	13	8.3. Reset Values	86
Part 2: Signal/Connection Descriptions	14	Part 9: Joint Test Action Group (JTAG)	91
2.1. Introduction	14	9.1. 56F8014 Information	91
2.2. 56F8014 Signal Pins	18	Part 10: Specifications	91
Part 3: OCCS	26	10.1. General Characteristics	91
3.1. Overview	26	10.2. DC Electrical Characteristics	95
3.2. Features	26	10.3. AC Electrical Characteristics	97
3.3. Operating Modes	26	10.4. Flash Memory Characteristics	98
3.4. Block Diagram	28	10.5. External Clock Operation Timing	99
3.5. Pin Descriptions	29	10.6. Phase Locked Loop Timing	99
Part 4: Memory Map	29	10.7. Relaxation Oscillator Timing	100
4.1. Introduction	29	10.8. Reset, Stop, Wait, Mode Select, and	
4.2. Interrupt Vector Table	29	Interrupt Timing	101
4.3. Program Map	31	10.9. Serial Peripheral Interface (SPI) Timing	102
4.4. Data Map	32	10.10. Quad Timer Timing	105
4.5. EOnCE Memory Map	32	10.11. Serial Communication Interface (SCI)	
4.6. Peripheral Memory Mapped Registers	33	Timing	107
Part 5: Interrupt Controller (ITCN)	43	10.12. Inter-Integrated Circuit Interface (I2C)	
5.1. Introduction	43	Timing	108
5.2. Features	43	10.13. JTAG Timing	109
5.3. Functional Description	43	10.14. Analog-to-Digital Converter (ADC)	
5.4. Block Diagram	45	Parameters	111
5.5. Register Descriptions	45	10.15. Equivalent Circuit for ADC Inputs	112
5.6. Resets	61	10.16. Power Consumption	112
Part 6: System Integration Module (SIM)	62	Part 11: Packaging	115
6.1. Introduction	62	11.1. 56F8014 Package and Pin-Out	
6.2. Features	62	Information	115
6.3. Register Descriptions	64	Part 12: Design Considerations	118
6.4. Clock Generation Overview	77	12.1. Thermal Design Considerations	118
6.5. Power-Down Modes	77	12.2. Electrical Design Considerations	119
6.6. Resets	79	Part 13: Ordering Information	121
6.7. Clocks	81	Part 14: Appendix	122
6.8. Interrupts	82		

Part 1 Overview

1.1 56F8014 Features

1.1.1 Digital Signal Controller Core

- Efficient 16-bit 56800E family Digital Signal Controller (DSC) engine with dual Harvard architecture
- As many as 32 Million Instructions Per Second (MIPS) at 32MHz core frequency
- Single-cycle 16×16 -bit parallel Multiplier-Accumulator (MAC)
- Four 36-bit accumulators, including extension bits
- 32-bit arithmetic and logic multi-bit shifter
- Parallel instruction set with unique DSP addressing modes
- Hardware DO and REP loops
- Three internal address buses
- Four internal data buses
- Instruction set supports both DSP and controller functions
- Controller-style addressing modes and instructions for compact code
- Efficient C compiler and local variable support
- Software subroutine and interrupt stack with depth limited only by memory
- JTAG/Enhanced On-Chip Emulation (OnCE) for unobtrusive, processor speed-independent, real-time debugging

1.1.2 Memory

- Dual Harvard architecture permits as many as three simultaneous accesses to program and data memory
- Flash security and protection that prevent unauthorized users from gaining access to the internal Flash
- On-chip memory
 - 16KB of Program Flash
 - 4KB of Unified Data/Program RAM
- EEPROM emulation capability using Flash

1.1.3 Peripheral Circuits for 56F8014

- One multi-function five-output Pulse Width Modulator (PWM) module
 - Up to 96MHz PWM operating clock
 - 15 bits of resolution
 - Center-aligned and Edge-aligned PWM signal mode
 - Three programmable fault inputs with programmable digital filter
 - Double-buffered PWM registers

- Each complementary PWM signal pair can output a different switching frequency by selecting PWM generation sources from:
 - PWM generator
 - External GPIO
 - Internal timers
 - ADC conversion result of over/under limits:
 - When conversion result is greater than high limit, deactivate PWM signal
 - When conversion result is less than low limit, activate PWM signal
- Two independent 12-bit Analog-to-Digital Converters (ADCs)
 - 2 x 4 channel inputs
 - Supports both simultaneous and sequential conversions
 - ADC conversions can be synchronized by both PWM and timer modules
 - Sampling rate up to 2.67MSPS
 - 8-word result buffer registers
 - ADC Smart Power Management (Auto-standby, auto-powerdown)
- One 16-bit multi-purpose Quad Timer module (TMR)
 - Up to 96MHz operating clock
 - Four independent 16-bit counter/timers with cascading capability
 - Each timer has capture and compare capability
 - Up to 12 operating modes
- One Serial Communication Interface (SCI) with LIN slave functionality
 - Full-duplex or single-wire operation
 - Two receiver wake-up methods:
 - Idle line
 - Address mark
- One Serial Peripheral Interface (SPI)
 - Full-duplex operation
 - Master and slave modes
 - Programmable length transactions (two to sixteen bits)
- One Inter-Integrated Circuit (I²C) port
 - Operates up to 400 kbps
 - Supports both master and slave operation
- Computer Operating Properly (COP)/Watchdog timer capable of selecting different clock sources
- Up to 26 General-Purpose I/O (GPIO) pins with 5V tolerance
- Integrated Power-On Reset and Low-Voltage Interrupt Module
- Phase Lock Loop (PLL) provides a high-speed clock to the core and peripherals
- Clock Sources:
 - On-chip relaxation oscillator

- External clock source
- On-chip regulators for digital and analog circuitry to lower cost and reduce noise
- JTAG/EOnCE debug programming interface for real-time debugging

1.1.4 Energy Information

- Fabricated in high-density CMOS with 5V-tolerant, TTL-compatible digital inputs
- On-chip regulators for digital and analog circuitry to lower cost and reduce noise
- Wait and Stop modes available
- ADC smart power management
- Each peripheral can be individually disabled to save power

1.2 56F8014 Description

The 56F8014 is a member of the 56800E core-based family of Digital Signal Controllers (DSCs). It combines, on a single chip, the processing power of a DSP and the functionality of a microcontroller with a flexible set of peripherals to create an extremely cost-effective solution. Because of its low cost, configuration flexibility, and compact program code, the 56F8014 is well-suited for many applications. The 56F8014 includes many peripherals that are especially useful for industrial control, motion control, home appliances, general purpose inverters, smart sensors, fire and security systems, switched-mode power supplies, power management, and medical monitoring applications.

The 56800E core is based on a dual Harvard-style architecture consisting of three execution units operating in parallel, allowing as many as six operations per instruction cycle. The MCU-style programming model and optimized instruction set allow straightforward generation of efficient, compact DSP and control code. The instruction set is also highly efficient for C compilers to enable rapid development of optimized control applications.

The 56F8014 supports program execution from internal memories. Two data operands can be accessed from the on-chip data RAM per instruction cycle. The 56F8014 also offers up to 26 General Purpose Input/Output (GPIO) lines, depending on peripheral configuration.

The 56F8014 Digital Signal Controller includes 16KB of Program Flash and 4KB of Unified Data/Program RAM. Program Flash memory can be independently bulk erased or erased in pages. Program Flash page erase size is 512 Bytes/256 Words.

A full set of programmable peripherals—PWM, ADCs, SCI, SPI, I²C, Quad Timer—support various applications. Each peripheral can be independently shut down to save power. Any pin in these peripherals can also be used as a General Purpose Input/Outputs (GPIO).

1.3 Award-Winning Development Environment

Processor ExpertTM (PE) provides a Rapid Application Design (RAD) tool that combines easy-to-use component-based software application creation with an expert knowledge system.

The CodeWarrior Integrated Development Environment is a sophisticated tool for code navigation, compiling, and debugging. A complete set of evaluation modules (EVMs), demonstration board kit and development system cards will support concurrent engineering. Together, PE, CodeWarrior and EVMs

create a complete, scalable tools solution for easy, fast, and efficient development.

1.4 Architecture Block Diagram

The 56F8014's architecture is shown in [Figure 1-1](#), [Figure 1-2](#), and [Figure 1-3](#). [Figure 1-1](#) illustrates how the 56800E system buses communicate with internal memories and the IPBus Bridge, as well as showing the internal connections between each unit of the 56800E core. [Figure 1-2](#) shows the peripherals and control blocks connected to the IPBus Bridge. [Figure 1-3](#) details how the device's I/O pins are muxed. The figures do not show the on-board regulator and power and ground signals. They also do not show the multiplexing between peripherals or the dedicated GPIOs. Please see [Part 2 Signal/Connection Descriptions](#) to see which signals are multiplexed with those of other peripherals.

1.5 Synchronize ADC with PWM

ADC conversion can be synchronized with the PWM module via Quad Timer channel 2 and 3 if needed. Internally, the PWM synch signal — which is generated at every PWM reload — can be connected to the timer channel 3 input, and the timer channel 2 and channel 3 outputs are connected to the ADC sync inputs. Timer channel 3 output is connected to SYNC0 and timer channel 2 is connected to SYNC1. The setting is controlled by the TC3_INP bit in the SIM Control Register; see [Section 6.3.1](#).

SYNC0 is the master ADC sync input, used to trigger both ADCA and ADCB in sequence and parallel mode. SYNC1 is used to trigger ADCB in parallel independent mode, while SYNC0 is used to trigger ADCA. See *MC56F8000RM*, the 56F801X Peripheral Reference Manual, for additional information.

1.6 Multiple Frequency PWM Output

When both PWM channels of a complementary pair in software control mode and software control bits are set to 1, each complementary PWM signal pair — PWM 0 and 1; PWM 2 and 3; and PWM 4 and 5 — can select a PWM source from one of the following sources. This will enable each PWM pair and PWM2 to output PWM signals at different frequencies.

- External GPIO input:
 - GPIOB2 input can be used to drive PWM 0 and 1
 - GPIOB3 input can be used to drive PWM 2
 - GPIOB4 input can be used to drive PWM 4 and 5
- Quad Timer output:
 - Timer0 output can be used to drive PWM 0 and 1
 - Timer2 output can be used to drive PWM 2
 - Timer3 output can be used to drive PWM 4 and 5
- ADC conversion result:
 - Signal of over/under limit of ADC sample 0 can be used to drive PWM 0 and 1
 - Signal of over/under limit of ADC sample 1 can be used to drive PWM 2

— Signal of over/under limit of ADC sample 2 can be used to drive PWM 4 and 5

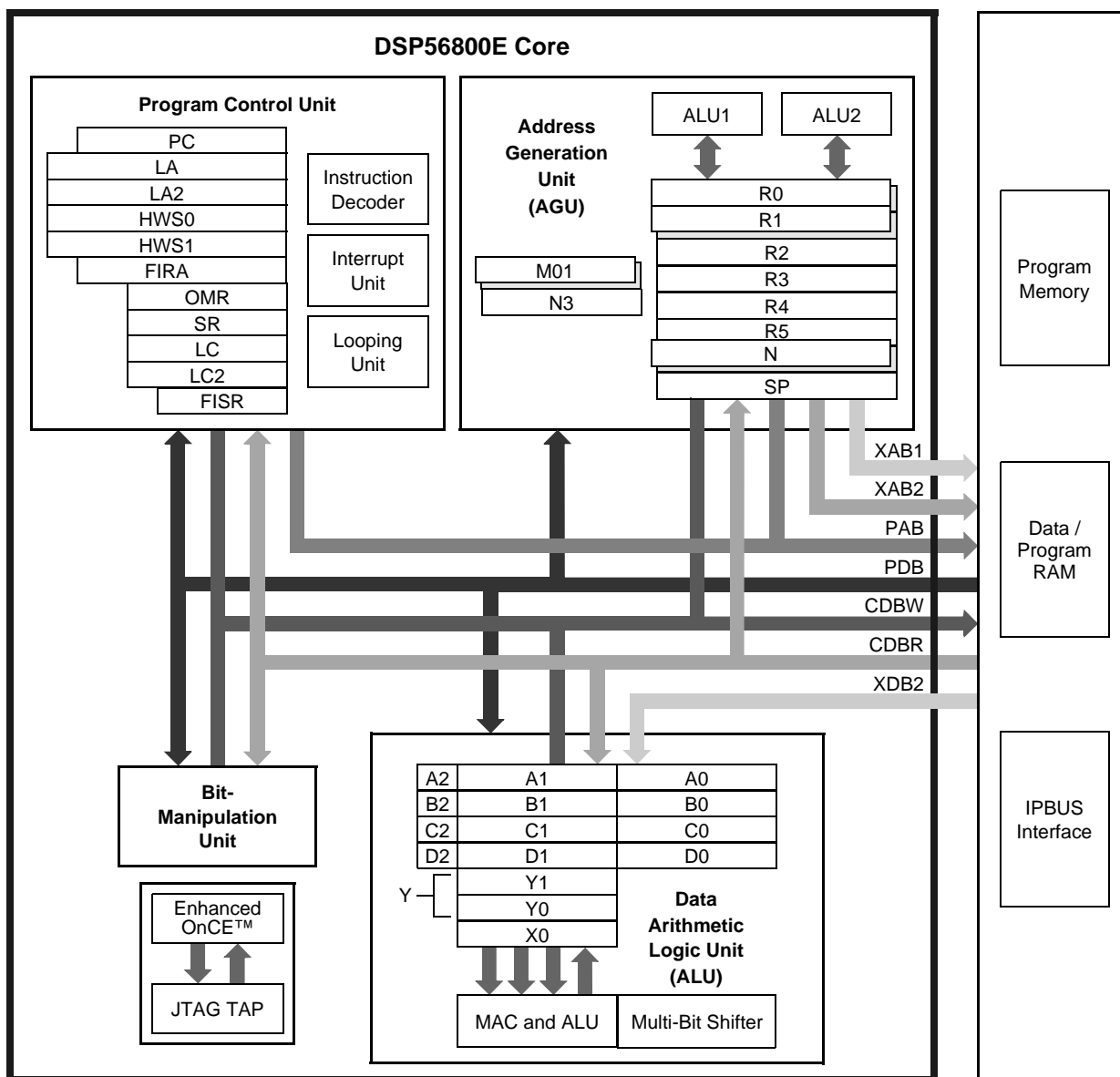

Figure 1-1 56800E Core Block Diagram

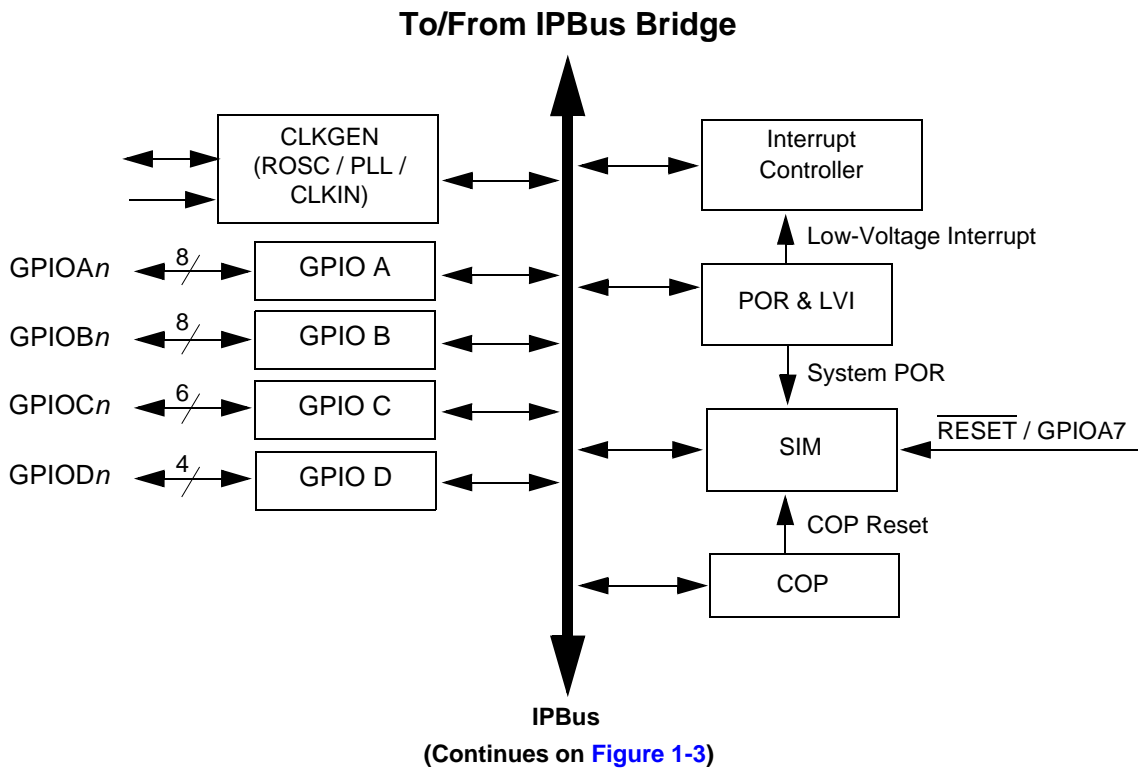

Figure 1-2 Peripheral Subsystem

(Continued from Figure 1-2)
To/From IPBus Bridge

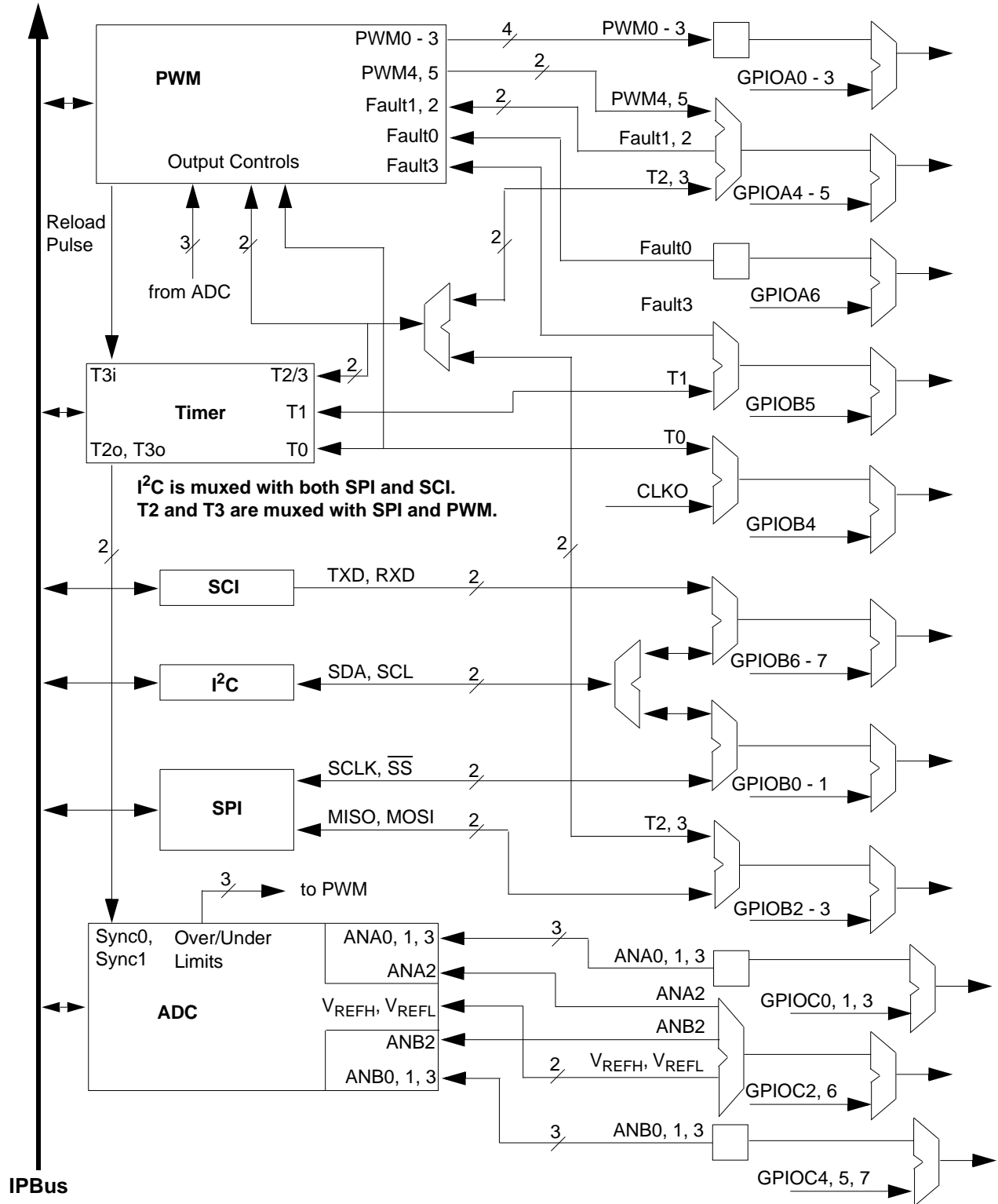

Figure 1-3 56F8014 Peripheral I/O Pin-Out

1.7 Product Documentation

The documents listed in [Table 1-1](#) are required for a complete description and proper design with the 56F8014. Documentation is available from local Freescale distributors, Freescale Semiconductor sales offices, Freescale Literature Distribution Centers, or online at:

<http://www.freescale.com>

Table 1-1 56F8014 Chip Documentation

Topic	Description	Order Number
DSP56800E Reference Manual	Detailed description of the 56800E family architecture, 16-bit Digital Signal Controller core processor, and the instruction set	DSP56800ERM
56F801X Peripheral Reference Manual	Detailed description of peripherals of the 56F801X family of devices	MC56F8000RM
56F801x Serial Bootloader User Guide	Detailed description of the Serial Bootloader in the 56F801x family of devices	56F801xBLUG
56F8014 Technical Data Sheet	Electrical and timing specifications, pin descriptions, and package descriptions (this document)	MC56F8014
56F8014 Errata	Details any chip issues that might be present	MC56F8014E

1.8 Data Sheet Conventions

This data sheet uses the following conventions:

$\overline{\text{OVERBAR}}$ This is used to indicate a signal that is active when pulled low. For example, the $\overline{\text{RESET}}$ pin is active when low.

“asserted” A high true (active high) signal is high or a low true (active low) signal is low.

“deasserted” A high true (active high) signal is low or a low true (active low) signal is high.

Examples:	Signal/Symbol	Logic State	Signal State	Voltage ¹
	$\overline{\text{PIN}}$	True	Asserted	V_{IL}/V_{OL}
	$\overline{\text{PIN}}$	False	Deasserted	V_{IH}/V_{OH}
	PIN	True	Asserted	V_{IH}/V_{OH}
	PIN	False	Deasserted	V_{IL}/V_{OL}

1. Values for V_{IL} , V_{OL} , V_{IH} , and V_{OH} are defined by individual product specifications.

Part 2 Signal/Connection Descriptions

2.1 Introduction

The input and output signals of the 56F8014 are organized into functional groups, as detailed in [Table 2-1](#). [Table 2-2](#) summarizes all device pins. In [Table 2-2](#), each table row describes the signal or signals present on a pin, sorted by pin number.

Table 2-1 Functional Group Pin Allocations

Functional Group	Number of Pins
Power (V_{DD} or V_{DDA})	2
Ground (V_{SS} or V_{SSA})	3
Supply Capacitors	1
Reset	1
Pulse Width Modulator (PWM) Ports ¹	5
Serial Peripheral Interface (SPI) Ports ²	4
Analog-to-Digital Converter (ADC) Ports	8
Timer Module Ports ³	2
Serial Communications Interface (SCI) Ports ⁴	2
JTAG/Enhanced On-Chip Emulation (EOnCE)	4

1. Pins in this section can function as TMR and GPIO.
2. Pins in this section can function as TMR, I²C, and GPIO.
3. Pins can function as PWM and GPIO.
4. Pins in this section can function as I²C and GPIO.

Table 2-2 56F8014 Pins

			Peripherals:									
LQFP Pin #	Pin Name	Signal Name	GPIO	I2C	SCI	SPI	ADC	PWM	Quad Timer	Power & Ground	JTAG	Misc.
1	GPIOB1	GPIOB1, \overline{SS} , SDA	B1	SDA		\overline{SS}						
2	GPIOB7	GPIOB7, TXD, SCL	B7	SCL	TXD							
3	GPIOB5	GPIOB5, T1, FAULT3	B5					FAULT3	T1			
4	ANB0	ANB0, GPIOC4	C4				ANB0					
5	ANB1	ANB1, GPIOC5	C5				ANB1					
6	ANB2	ANB2, V_{REFL} , GPIOC6	C6				ANB2 , V_{REFL}					
7	ANB3	ANB3, GPIOC7	C7				ANB3					
8	VDDA	V_{DDA}								V_{DDA}		
9	VSSA	V_{SSA}								V_{SSA}		
10	ANA3	ANA3, GPIOC3	C3				ANA3					
11	ANA2	ANA2, V_{REFH} , GPIOC2	C2				ANA2 , V_{REFH}					
12	ANA1	ANA1, GPIOC1	C1				ANA1					
13	ANA0	ANA0, GPIOC0	C0				ANA0					
14	VSS_IO	V_{SS_IO}								V_{SS_IO}		
15	TCK	TCK, GPIOD2	D2								TCK	
16	RESET	\overline{RESET} , GPIOA7	A7									RESET
17	GPIOB3	GPIOB3, MOSI, T3	B3			MOSI			T3			
18	GPIOB2	GPIOB2, MISO, T2	B2			MISO			T2			
19	GPIOB4	GPIOB4, T0, CLKO	B4						T0			CLKO
20	GPIOA5	GPIOA5, PWM5, FAULT2, T3	A5					PWM5, FAULT2	T3			
21	GPIOB0	GPIOB0, SCLK, SCL	B0	SCL		SCLK						
22	GPIOA4	GPIOA4, PWM4, FAULT1, T2	A4					PWM4, FAULT1	T2			
23	GPIOA2	GPIOA2, PWM2	A2					PWM2				
24	VCAP	V_{CAP}								V_{CAP}		

Table 2-2 56F8014 Pins (Continued)

			Peripherals:									
LQFP Pin #	Pin Name	Signal Name	GPIO	I2C	SCI	SPI	ADC	PWM	Quad Timer	Power & Ground	JTAG	Misc.
25	VDD_IO	V _{DD_IO}								V _{DD_IO}		
26	VSS_IO	V _{SS_IO}								V _{SS_IO}		
27	GPIOA1	GPIOA1, PWM1	A1					PWM1				
28	GPIOA0	GPIOA0, PWM0	A0					PWM0				
29	TDI	TDI, GPIOD0	D0								TDI	
30	TMS	TMS, GPIOD3	D3								TMS	
31	TDO	TDO, GPIOD1	D1								TDO	
32	GPIOB6	GPIOB6, RXD, SDA, CLKIN	B6	SDA	RXD							CLKIN

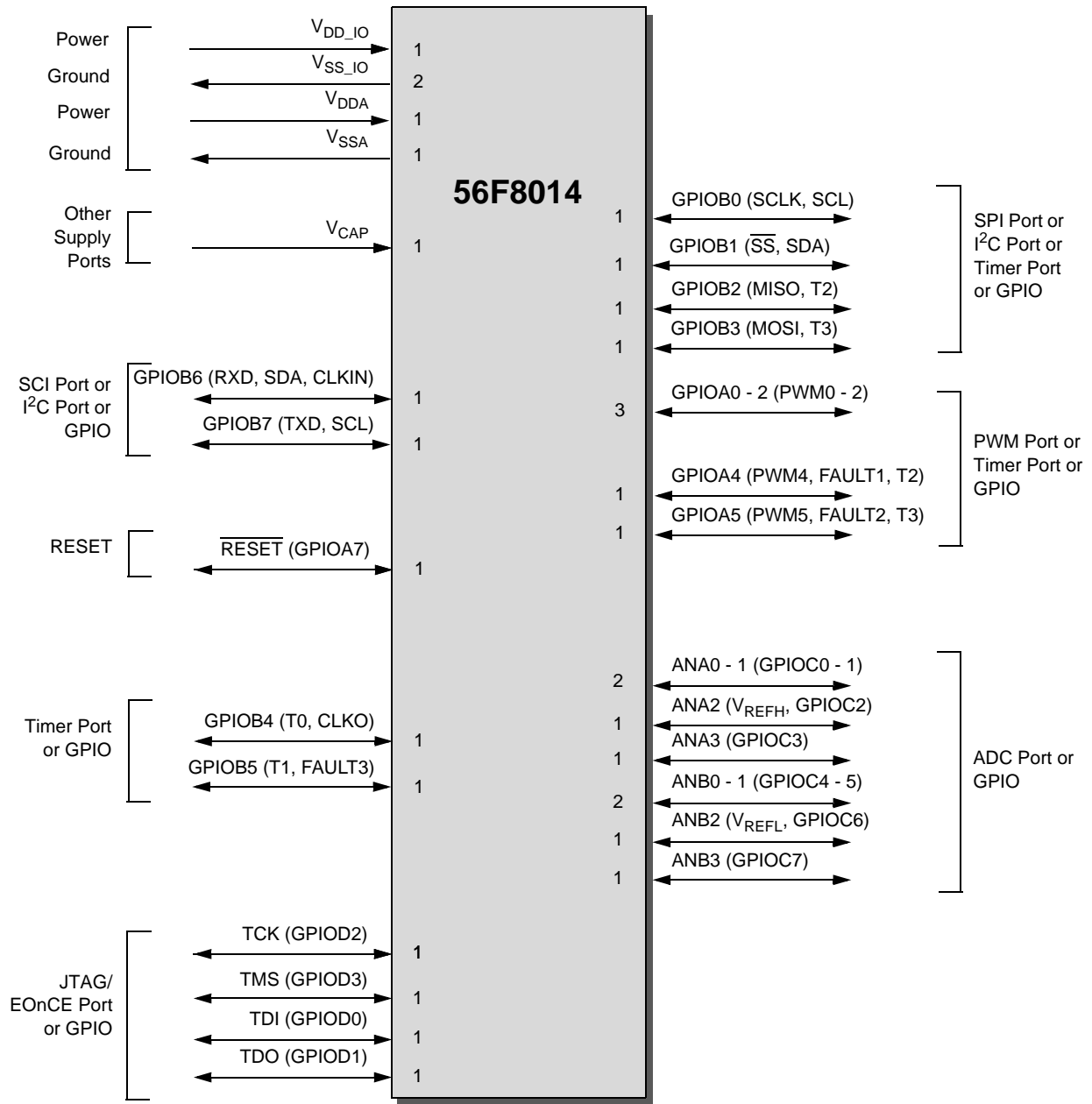

Figure 2-1 56F8014 Signals Identified by Functional Group (32-Pin LQFP)

2.2 56F8014 Signal Pins

After reset, each pin is configured for its primary function (listed first). Any alternate functionality must be programmed.

Table 2-3 56F8014 Signal and Package Information for the 32-Pin LQFP

Signal Name	LQFP Pin No.	Type	State During Reset	Signal Description
V _{DD_IO}	25	Supply	Supply	I/O Power — This pin supplies 3.3V power to the chip I/O interface.
V _{SS_IO}	14	Supply	Supply	V_{SS} — These pins provide ground for chip logic and I/O drivers.
V _{SS_IO}	26			
V _{DDA}	8	Supply	Supply	ADC Power — This pin supplies 3.3V power to the ADC modules. It must be connected to a clean analog power supply.
V _{SSA}	9	Supply	Supply	ADC Analog Ground — This pin supplies an analog ground to the ADC modules.
V _{CAP}	24	Supply	Supply	V_{CAP} — Connect a 2.2 μ F or greater bypass capacitor between this pin and V _{SS_IO} , which is required by the internal voltage regulator for proper chip operation. See Section 10.2.1 .
GPIOB6 (RXD) (SDA ¹) (CLKIN)	32	Input/ Output Input Input/ Output Input	Input with internal pull-up enabled	<p>Port B GPIO — This GPIO pin can be individually programmed as an input or output pin.</p> <p>Receive Data — SCI receive data input.</p> <p>Serial Data — This pin serves as the I²C serial data line.</p> <p>Clock Input — This pin serves as an optional external clock input.</p> <p>After reset, the default state is GPIOB6. The alternative peripheral functionality is controlled via the SIM (See Section 6.3.8) and the CLKMODE bit of the OCCS Oscillator Control Register.</p>
1. This signal is also brought out on the GPIOB1 pin.				

Return to [Table 2-2](#)

Table 2-3 56F8014 Signal and Package Information for the 32-Pin LQFP (Continued)

Signal Name	LQFP Pin No.	Type	State During Reset	Signal Description
GPIOB7 (TXD) (SCL²)	2	Input/ Output Input/ Output Input/ Output	Input with internal pull-up enabled	<p>Port B GPIO — This GPIO pin can be individually programmed as an input or output pin.</p> <p>Transmit Data — SCI transmit data output or transmit / receive in single wire operation.</p> <p>Serial Clock — This pin serves as the I²C serial clock.</p> <p>After reset, the default state is GPIOB7. The alternative peripheral functionality is controlled via the SIM. See Section 6.3.8.</p>
2. This signal is also brought out on the GPIOB0 pin.				
$\overline{\text{RESET}}$ (GPIOA7)	16	Input Input/Open Drain Output	Input with internal pull-up enabled	<p>Reset — This input is a direct hardware reset on the processor. When $\overline{\text{RESET}}$ is asserted low, the chip is initialized and placed in the reset state. A Schmitt trigger input is used for noise immunity. The internal reset signal will be deasserted synchronous with the internal clocks after a fixed number of internal clocks.</p> <p>Port A GPIO — This GPIO pin can be individually programmed as an input or open drain output pin. Note that $\overline{\text{RESET}}$ functionality is disabled in this mode and the chip can only be reset via POR, COP reset, or software reset.</p> <p>After reset, the default state is $\overline{\text{RESET}}$.</p>
GPIOB4 (T0) (CLKO)	19	Input/ Output Input/ Output Output	Input with internal pull-up enabled	<p>Port B GPIO — This GPIO pin can be individually programmed as an input or output pin.</p> <p>T0 — Timer, Channel 0</p> <p>Clock Output — This is a buffered clock signal. Using the SIM_CLKO Select Register (SIM_CLKOSR), this pin can be programmed as any of the following: disabled (logic 0), CLK_MSTR (system clock), IPBus clock, or oscillator output. See Section 6.3.7.</p> <p>After reset, the default state is GPIOB4. The alternative peripheral functionality is controlled via the SIM. See Section 6.3.8.</p>

 Return to [Table 2-2](#)

Table 2-3 56F8014 Signal and Package Information for the 32-Pin LQFP (Continued)

Signal Name	LQFP Pin No.	Type	State During Reset	Signal Description
GPIOB5 (T1) (FAULT3)	3	Input/ Output Input/ Output Input	Input with internal pull-up enabled	<p>Port B GPIO — This GPIO pin can be individually programmed as an input or output pin.</p> <p>T1 — Timer, Channel 1</p> <p>FAULT3 — This fault input pin is used for disabling selected PWM outputs in cases where fault conditions originate off-chip.</p> <p>After reset, the default state is GPIOB5. The alternative peripheral functionality is controlled via the SIM. See Section 6.3.8.</p>
TCK (GPIOD2)	15	Input Input/ Output	Input with internal pull-up enabled	<p>Test Clock Input — This input pin provides a gated clock to synchronize the test logic and shift serial data to the JTAG/EOnCE port. The pin is connected internally to a pull-up resistor. A Schmitt trigger input is used for noise immunity.</p> <p>Port D GPIO — This GPIO pin can be individually programmed as an input or output pin.</p> <p>After reset, the default state is TCK.</p>
TMS (GPIOD3)	30	Input Input/ Output	Input with internal pull-up enabled	<p>Test Mode Select Input — This input pin is used to sequence the JTAG TAP controller's state machine. It is sampled on the rising edge of TCK and has an on-chip pull-up resistor.</p> <p>Port D GPIO — This GPIO pin can be individually programmed as an input or output pin.</p> <p>After reset, the default state is TMS.</p> <p>Note: Always tie the TMS pin to V_{DD} through a 2.2K resistor if this pin is configured as TMS.</p>
TDI (GPIOD0)	29	Input Input/ Output	Input with internal pull-up enabled	<p>Test Data Input — This input pin provides a serial input data stream to the JTAG/EOnCE port. It is sampled on the rising edge of TCK and has an on-chip pull-up resistor.</p> <p>Port D GPIO — This GPIO pin can be individually programmed as an input or output pin.</p> <p>After reset, the default state is TDI.</p>

Return to [Table 2-2](#)

Table 2-3 56F8014 Signal and Package Information for the 32-Pin LQFP (Continued)

Signal Name	LQFP Pin No.	Type	State During Reset	Signal Description
TDO (GPIOD1)	31	Output Input/ Output	Output	<p>Test Data Output — This tri-stateable output pin provides a serial output data stream from the JTAG/EOnCE port. It is driven in the shift-IR and shift-DR controller states, and changes on the falling edge of TCK.</p> <p>Port D GPIO — This GPIO pin can be individually programmed as an input or output pin.</p> <p>After reset, the default state is TDO.</p>
GPIOB0 (SCLK) (SCL³)	21	Input/ Output Input/ Output Input/ Output	Input with internal pull-up enabled	<p>Port B GPIO — This GPIO pin can be individually programmed as an input or output pin.</p> <p>SPI Serial Clock — In the master mode, this pin serves as an output, clocking slaved listeners. In slave mode, this pin serves as the data clock input. A Schmitt trigger input is used for noise immunity.</p> <p>Serial Data — This pin serves as the I²C serial clock.</p> <p>After reset, the default state is GPIOB0. The alternative peripheral functionality is controlled via the SIM. See Section 6.3.8.</p>
3. This signal is also brought out on the GPIOB7 pin.				
GPIOB1 (\overline{SS}) (SDA⁴)	1	Input/ Output Input Input/ Output	Input with internal pull-up enabled	<p>Port B GPIO — This GPIO pin can be individually programmed as an input or output pin.</p> <p>SPI Slave Select — \overline{SS} is used in slave mode to indicate to the SPI module that the current transfer is to be received.</p> <p>Serial Clock — This pin serves as the I²C serial data line.</p> <p>After reset, the default state is GPIOB1. The alternative peripheral functionality is controlled via the SIM. See Section 6.3.8.</p>
4. This signal is also brought out on the GPIOB6 pin.				

 Return to [Table 2-2](#)

Table 2-3 56F8014 Signal and Package Information for the 32-Pin LQFP (Continued)

Signal Name	LQFP Pin No.	Type	State During Reset	Signal Description
GPIOB2	18	Input/ Output	Input with internal pull-up enabled	Port B GPIO — This GPIO pin can be individually programmed as an input or output pin.
(MISO)		Input/ Output		SPI Master In/Slave Out — This serial data pin is an input to a master device and an output from a slave device. The MISO line of a slave device is placed in the high-impedance state if the slave device is not selected. The slave device places data on the MISO line a half-cycle before the clock edge the master device uses to latch the data.
(T2⁵)		Input/ Output		T2 — Timer, Channel 2 After reset, the default state is GPIOB2. The alternative peripheral functionality is controlled via the SIM. See Section 6.3.8 .
5. This signal is also brought out on the GPIOA4 pin.				
GPIOB3	17	Input/ Output	Input with internal pull-up enabled	Port B GPIO — This GPIO pin can be individually programmed as an input or output pin.
(MOSI)		Input/ Output		SPI Master Out/Slave In — This serial data pin is an output from a master device and an input to a slave device. The master device places data on the MOSI line a half-cycle before the clock edge the slave device uses to latch the data.
(T3⁶)		Input/ Output		T3 — Timer, Channel 3 After reset, the default state is GPIOB3. The alternative peripheral functionality is controlled via the SIM. See Section 6.3.8 .
6. This signal is also brought out on the GPIOA5 pin.				
GPIOA0	28	Input/ Output	Input with internal pull-up enabled	Port A GPIO — This GPIO pin can be individually programmed as an input or output pin.
(PWM0)		Output		PWM0 — This is one of the six PWM output pins. After reset, the default state is GPIOA0.

Return to [Table 2-2](#)

Table 2-3 56F8014 Signal and Package Information for the 32-Pin LQFP (Continued)

Signal Name	LQFP Pin No.	Type	State During Reset	Signal Description
GPIOA1 (PWM1)	27	Input/ Output Output	Input with internal pull-up enabled	Port A GPIO — This GPIO pin can be individually programmed as an input or output pin. PWM1 — This is one of the six PWM output pins. After reset, the default state is GPIOA1.
GPIOA2 (PWM2)	23	Input/ Output Output	Input with internal pull-up enabled	Port A GPIO — This GPIO pin can be individually programmed as an input or output pin. PWM2 — This is one of the six PWM output pins. After reset, the default state is GPIOA2.
GPIOA4 (PWM4) (FAULT1) (T2⁷)	22	Input/ Output Output Input Input/ Output	Input with internal pull-up enabled	Port A GPIO — This GPIO pin can be individually programmed as an input or output pin. PWM4 — This is one of the six PWM output pins. Fault1 — This fault input pin is used for disabling selected PWM outputs in cases where fault conditions originate off-chip. T2 — Timer, Channel 2 After reset, the default state is GPIOA4. The alternative peripheral functionality is controlled via the SIM. See Section 6.3.8 .
7. This signal is also brought out on the GPIOB2 pin.				
GPIOA5 (PWM5) (FAULT2) (T3⁸)	20	Input/ Output Output Input Input/ Output	Input with internal pull-up enabled	Port A GPIO — This GPIO pin can be individually programmed as an input or output pin. PWM5 — This is one of the six PWM output pins. Fault2 — This fault input pin is used for disabling selected PWM outputs in cases where fault conditions originate off-chip. T3 — Timer, Channel 3 After reset, the default state is GPIOA5. The alternative peripheral functionality is controlled via the SIM. See Section 6.3.8 .
8. This signal is also brought out on the GPIOB3 pin.				

 Return to [Table 2-2](#)

Table 2-3 56F8014 Signal and Package Information for the 32-Pin LQFP (Continued)

Signal Name	LQFP Pin No.	Type	State During Reset	Signal Description
ANA0 (GPIOC0)	13	Input Input/ Output	Analog Input	ANA0 — Analog input to ADC A, channel 0 Port C GPIO — This GPIO pin can be individually programmed as an input or output pin. After reset, the default state is ANA0.
ANA1 (GPIOC1)	12	Input Input/ Output	Analog Input	ANA1 — Analog input to ADC A, channel 1 Port C GPIO — This GPIO pin can be individually programmed as an input or output pin. After reset, the default state is ANA1.
ANA2 (V_{REFH}) (GPIOC2)	11	Input Input Input/ Output	Analog Input	ANA2 — Analog input to ADC A, channel 2 V_{REFH} — Analog reference voltage high Port C GPIO — This GPIO pin can be individually programmed as an input or output pin. After reset, the default state is ANA2.
ANA3 (GPIOC3)	10	Input Input/ Output	Analog Input	ANA3 — Analog input to ADC A, channel 3 Port C GPIO — This GPIO pin can be individually programmed as an input or output pin. After reset, the default state is ANA3.
ANB0 (GPIOC4)	4	Input Input/ Output	Analog Input	ANB0 — Analog input to ADC B, channel 0 Port C GPIO — This GPIO pin can be individually programmed as an input or output pin. After reset, the default state is ANB0.

Return to [Table 2-2](#)

Table 2-3 56F8014 Signal and Package Information for the 32-Pin LQFP (Continued)

Signal Name	LQFP Pin No.	Type	State During Reset	Signal Description
ANB1 (GPIOC5)	5	Input Input/ Output	Analog Input	ANB1 — Analog input to ADC B, channel 1 Port C GPIO — This GPIO pin can be individually programmed as an input or output pin. After reset, the default state is ANB1.
ANB2 (V_{REFL}) (GPIOC6)	6	Input Input Input/ Output	Analog Input	ANB2 — Analog input to ADC B, channel 2 V_{REFL} — Analog reference voltage low. This should normally be connected to a low-noise V _{SS} . Port C GPIO — This GPIO pin can be individually programmed as an input or output pin. After reset, the default state is ANB2.
ANB3 (GPIOC7)	7	Input Input/ Output	Analog Input	ANB3 — Analog input to ADC B, channel 3 Port C GPIO — This GPIO pin can be individually programmed as an input or output pin. After reset, the default state is ANB3.

Return to [Table 2-2](#)

Part 3 OCCS

3.1 Overview

This module provides the system clock, which uses it to generate the various chip clocks. This module also produces the oscillator clock signals, plus the ADC clock and high-speed peripheral clock.

The on-chip clock synthesis module allows product design using an internal relaxation oscillator to run 56F801X family parts at user-selectable frequencies up to 32MHz.

3.2 Features

The On-Chip Clock Synthesis (OCCS) module interfaces to the oscillator and PLL. The OCCS module features:

- Internal relaxation oscillator
- Ability to power down the internal relaxation oscillator
- Ability to put the internal relaxation oscillator into a standby mode
- 3-bit postscaler provides control for the PLL output
- Ability to power down the internal PLL
- Provides 2X system clock frequency, which operates at twice the system clock, to the System Integration Module (SIM) that is used to generate the various device clocks
- Provides 3X system clock, which operates at three times the system clock, to PWM and Timer
- Safety shutdown feature is available in the event that the PLL reference clock disappears
- Can be driven from an external clock source

The clock generation module provides the programming interface for both the PLL and internal relaxation oscillator.

3.3 Operating Modes

In 56F801X family parts, either an internal oscillator or an external frequency source can be used to provide a reference clock to the SIM.

The 2X system clock source output from the OCCS can be described by one of the following equations:

$$2X \text{ system frequency} = \text{oscillator frequency}$$

$$2X \text{ system frequency} = (\text{oscillator frequency} \times 8) / (\text{postscaler})$$

where:

$$\text{postscaler} = 1, 2, 4, 8, 16, \text{ or } 32 \text{ PLL output divider}$$

The SIM is responsible for further dividing these frequencies by two, which will insure a 50% duty cycle in the system clock output.

The 56F801X family parts' on-chip clock synthesis module has the following registers:

- Control Register (OCCS_CR)
- Divide-by Register (OCCS_DB)
- Status Register (OCCS_SR)
- Shutdown Register (OCCS_SHUTDOWN)
- Oscillator Control Register (OCCS_OCTRL)

For more information on these registers, please refer to the **56F801X Peripheral Reference Manual**.

3.3.1 External Clock Source

The recommended method of connecting an external clock is illustrated in [Figure 3-1](#). The external clock source is connected to GPIOB6 / RXD / SDA / CLKIN.

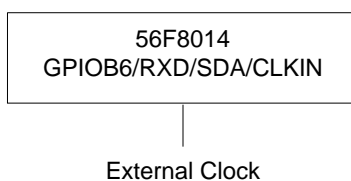

Figure 3-1 Connecting an External Clock Signal using GPIOB6 / RXD / SDA / CLKIN

3.4 Block Diagram

Figure 3-2 provides a block diagram which shows how the 56F8014 creates its internal clock, using the relaxation oscillator as an 8MHz clock reference for the PLL.

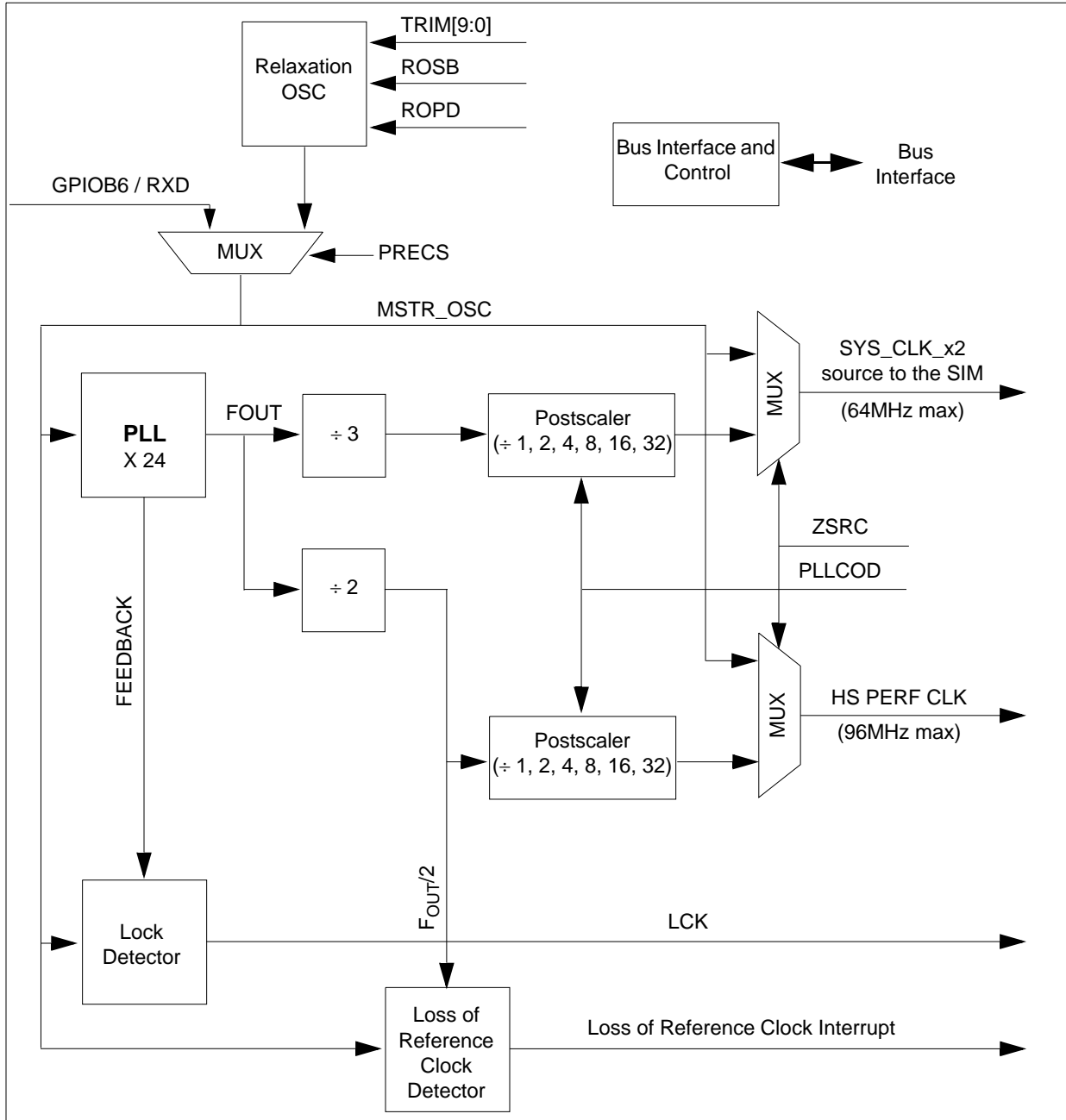

Figure 3-2 OCCS Block Diagram with Relaxation Oscillator

3.5 Pin Descriptions

3.5.1 External Reference (GPIOB6 / RXD / SDA / CLKIN)

After reset, the internal relaxation oscillator is selected as the clock source for the chip. The user then has the option of switching to an external clock reference by enabling the PRECS bit in the OCCS Oscillator Control register, if desired.

Part 4 Memory Map

4.1 Introduction

The 56F8014 device is a 16-bit motor-control chip based on the 56800E core. It uses a Harvard-style architecture with two independent memory spaces for Data and Program. On-chip RAM is used in both spaces and Flash memory is used only in Program space.

This section provides memory maps for:

- Program Address Space, including the Interrupt Vector Table
- Data Address Space, including the EOnCE Memory and Peripheral Memory Maps

On-chip memory sizes for the device are summarized in [Table 4-1](#). Flash memories' restrictions are identified in the "Use Restrictions" column of [Table 4-1](#).

Table 4-1 Chip Memory Configurations

On-Chip Memory	56F8014	Use Restrictions
Program Flash (PFLASH)	8k x 16	Erase / Program via Flash interface unit and word writes to CDBW
Unified RAM (ram)	2k x 16	Usable by both the Program and Data memory spaces

4.2 Interrupt Vector Table

[Table 4-2](#) provides the 56F8014's reset and interrupt priority structure, including on-chip peripherals. The table is organized with higher-priority vectors at the top and lower-priority interrupts lower in the table. As indicated, the priority of an interrupt can be assigned to different levels, allowing some control over interrupt priorities. All level 3 interrupts will be serviced before level 2, and so on. For a selected priority level, the lowest vector number has the highest priority.

The location of the vector table is determined by the Vector Base Address (VBA). Please see [Section 5.5.6](#) for the reset value of the VBA.

By default, the chip reset address and COP reset address will correspond to vector 0 and 1 of the interrupt vector table. In these instances, the first two locations in the vector table must contain branch or JMP instructions. All other entries must contain JSR instructions.

Table 4-2 Interrupt Vector Table Contents¹

Peripheral	Vector Number	Priority Level	Vector Base Address +	Interrupt Function
core			P:\$00	Reserved for Reset Overlay ²
core			P:\$02	Reserved for COP Reset Overlay
core	2	3	P:\$04	Illegal Instruction
core	3	3	P:\$06	SW Interrupt 3
core	4	3	P:\$08	HW Stack Overflow
core	5	3	P:\$0A	Misaligned Long Word Access
core	6	1-3	P:\$0C	EOnCE Step Counter
core	7	1-3	P:\$0E	EOnCE Breakpoint Unit 0
core	8	1-3	P:\$10	EOnCE Trace Buffer
core	9	1-3	P:\$12	EOnCE Transmit Register Empty
core	10	1-3	P:\$14	EOnCE Receive Register Full
core	11	2	P:\$16	SW Interrupt 2
core	12	1	P:\$18	SW Interrupt 1
core	13	0	P:\$1A	SW Interrupt 0
	14			Reserved
	15			Reserved
PS	16	0-2	P:\$20	Power Sense
OCCS	17	0-2	P:\$22	PLL Lock, Loss of Clock Reference Interrupt
FM	18	0-2	P:\$24	FM Access Error Interrupt
FM	19	0-2	P:\$26	FM Command Complete
FM	20	0-2	P:\$28	FM Command, data and address Buffers Empty
	21			Reserved
GPIOD	22	0-2	P:\$2C	GPIOD
GPIOC	23	0-2	P:\$2E	GPIOC
GPIOB	24	0-2	P:\$30	GPIOB
GPIOA	25	0-2	P:\$32	GPIOA
SPI	26	0-2	P:\$34	SPI Receiver Full / Error
SPI	27	0-2	P:\$36	SPI Transmitter Empty
SCI	28	0-2	P:\$38	SCI Transmitter Empty
SCI	29	0-2	P:\$3A	SCI Transmitter Idle
SCI	30	0-2	P:\$3C	SCI Reserved
SCI	31	0-2	P:\$3E	SCI Receiver Error
SCI	32	0-2	P:\$40	SCI Receiver Full
	33, 34			Reserved
I ² C	35	0-2	P:\$46	I ² C
Timer	36	0-2	P:\$48	Timer Channel 0
Timer	37	0-2	P:\$4A	Timer Channel 1
(Continues next page)				

Table 4-2 Interrupt Vector Table Contents¹ (Continued)

Peripheral	Vector Number	Priority Level	Vector Base Address +	Interrupt Function
Timer	38	0-2	P:\$4C	Timer Channel 2
Timer	39	0-2	P:\$4E	Timer Channel 3
ADC	40	0-2	P:\$50	ADCA Conversion Complete
ADC	41	0-2	P:\$52	ADCB Conversion Complete
ADC	42	0-2	P:\$54	ADC Zero Crossing or Limit Error
PWM	43	0-2	P:\$56	Reload PWM
PWM	44	0-2	P:\$58	PWM Fault
SWILP	45	-1	P:\$5A	SW Interrupt Low Priority

- Two words are allocated for each entry in the vector table. This does not allow the full address range to be referenced from the vector table, providing only 19 bits of address.
- If the VBA is set to the reset value, the first two locations of the vector table will overlay the chip reset addresses.

4.3 Program Map

The Program Memory map is shown in [Table 4-3](#).

Table 4-3 Program Memory Map¹

Begin/End Address	Memory Allocation
P: \$FF FFFF P: \$00 8800	RESERVED
P: \$00 87FF P: \$00 8000	On-Chip RAM ² 4KB
P: \$00 7FFF P: \$00 2000	RESERVED
P: \$00 1FFF P: \$00 0000	Internal Program Flash 16KB Cop Reset Address = \$00 0002 Boot Location = \$00 0000

- All addresses are 16-bit Word addresses.
- This RAM is shared with Data space starting at address X: \$00 0000; see [Figure 4-1](#).

4.4 Data Map

Table 4-4 Data Memory Map¹

Begin/End Address	Memory Allocation
X:\$FF FFFF X:\$FF FF00	EOnCE 256 locations allocated
X:\$FF FEFF X:\$01 0000	RESERVED
X:\$00 FFFF X:\$00 F000	On-Chip Peripherals 4096 locations allocated
X:\$00 EFFF X:\$00 8800	RESERVED
X:\$00 EFFF X:\$00 0800	Reserved
X:\$00 7FFF X:\$00 0040	RESERVED
X:\$00 07FF X:\$00 0000	On-Chip Data RAM ² 4KB

1. All addresses are 16-bit Word addresses.
2. This RAM is shared with Program space starting at P: \$00 8000; see [Figure 4-1](#).

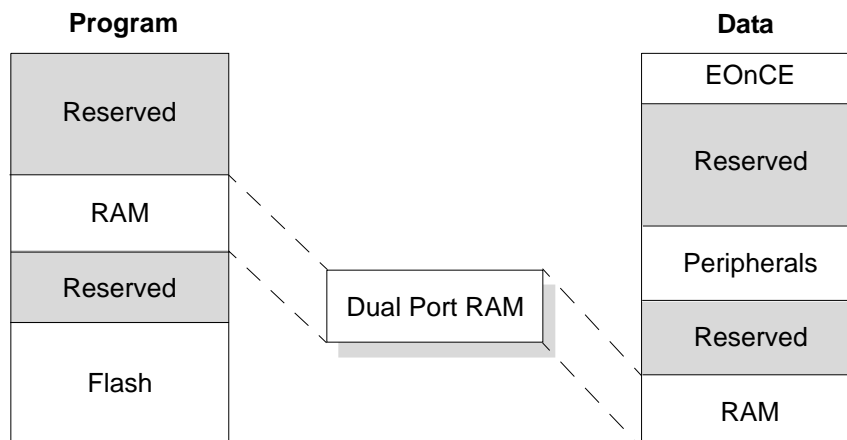

Figure 4-1 Dual Port RAM

4.5 EOnCE Memory Map

[Figure 4-5](#) lists all EOnCE registers necessary to access or control the EOnCE.

Table 4-5 EOnCE Memory Map

Address	Register Acronym	Register Name
X:\$FF FFFF	OTX1 / ORX1	Transmit Register Upper Word Receive Register Upper Word
X:\$FF FFFE	OTX / ORX (32 bits)	Transmit Register Receive Register
X:\$FF FFFD	OTXRCSR	Transmit and Receive Status and Control Register
X:\$FF FFFC	OCLSR	Core Lock / Unlock Status Register
X:\$FF FFFB - X:\$FF FFA1		Reserved
X:\$FF FFA0	OCR	Control Register
X:\$FF FF9F		Instruction Step Counter
X:\$FF FF9E	OSCNTR (24 bits)	Instruction Step Counter
X:\$FF FF9D	OSR	Status Register
X:\$FF FF9C	OBASE	Peripheral Base Address Register
X:\$FF FF9B	OTBCR	Trace Buffer Control Register
X:\$FF FF9A	OTBPR	Trace Buffer Pointer Register
X:\$FF FF99		Trace Buffer Register Stages
X:\$FF FF98	OTB (21 - 24 bits/stage)	Trace Buffer Register Stages
X:\$FF FF97		Breakpoint Unit Control Register
X:\$FF FF96	OBCR (24 bits)	Breakpoint Unit Control Register
X:\$FF FF95		Breakpoint Unit Address Register 1
X:\$FF FF94	OBAR1 (24 bits)	Breakpoint Unit Address Register 1
X:\$FF FF93		Breakpoint Unit Address Register 2
X:\$FF FF92	OBAR2 (32 bits)	Breakpoint Unit Address Register 2
X:\$FF FF91		Breakpoint Unit Mask Register 2
X:\$FF FF90	OBMSK (32 bits)	Breakpoint Unit Mask Register 2
X:\$FF FF8F		Reserved
X:\$FF FF8E	OBCNTR	EOnCE Breakpoint Unit Counter
X:\$FF FF8D		Reserved
X:\$FF FF8C		Reserved
X:\$FF FF8B		Reserved
X:\$FF FF8A	OESCR	External Signal Control Register
X:\$FF FF89 - X:\$FF FF00		Reserved

4.6 Peripheral Memory Mapped Registers

On-chip peripheral registers are part of the data memory map on the 56800E series. These locations may be accessed with the same addressing modes used for ordinary Data memory, except all peripheral registers should be read/written using word accesses only.

Table 4-6 summarizes base addresses for the set of peripherals on the 56F8014 device. Peripherals are listed in order of the base address.

The following tables list all of the peripheral registers required to control or access the peripherals.

Table 4-6 Data Memory Peripheral Base Address Map Summary

Peripheral	Prefix	Base Address	Table Number
Timer	TMR n	X:\$00 F000	4-7
PWM	PWM	X:\$00 F040	4-8
ITCN	ITCN	X:\$00 F060	4-9
ADC	ADC	X:\$00 F080	4-10
SCI	SCI	X:\$00 F0B0	4-11
SPI	SPI	X:\$00 F0C0	4-12
I ² C	I2C	X:\$00 F0D0	4-13
COP	COP	X:\$00 F0E0	4-14
CLK, PLL, OSC, TEST	OCCS	X:\$00 F0F0	4-15
GPIO Port A	GPIOA	X:\$00 F100	4-16
GPIO Port B	GPIOB	X:\$00 F110	4-17
GPIO Port C	GPIOC	X:\$00 F120	4-18
GPIO Port D	GPIOD	X:\$00 F130	4-19
SIM	SIM	X:\$00 F140	4-20
Power Supervisor	PS	X:\$00 F160	4-21
FM	FM	X:\$00 F400	4-22

**Table 4-7 Quad Timer Registers Address Map
(TMR_BASE = \$00 F000)**

Register Acronym	Address Offset	Register Description
TMR0_COMP1	\$0	Compare Register 1
TMR0_COMP2	\$1	Compare Register 2
TMR0_CAPT	\$2	Capture Register
TMR0_LOAD	\$3	Load Register
TMR0_HOLD	\$4	Hold Register
TMR0_CNTR	\$5	Counter Register
TMR0_CTRL	\$6	Control Register
TMR0_SCTRL	\$7	Status and Control Register
TMR0_CMPLD1	\$8	Comparator Load Register 1
TMR0_CMPLD2	\$9	Comparator Load Register 2
TMR0_CSCTRL	\$A	Comparator Status and Control Register
		Reserved
TMR1_COMP1	\$10	Compare Register 1
TMR1_COMP2	\$11	Compare Register 2

**Table 4-7 Quad Timer Registers Address Map (Continued)
(TMR_BASE = \$00 F000)**

Register Acronym	Address Offset	Register Description
TMR1_CAPT	\$12	Capture Register
TMR1_LOAD	\$13	Load Register
TMR1_HOLD	\$14	Hold Register
TMR1_CNTR	\$15	Counter Register
TMR1_CTRL	\$16	Control Register
TMR1_SCTRL	\$17	Status and Control Register
TMR1_CMPLD1	\$18	Comparator Load Register 1
TMR1_CMPLD2	\$19	Comparator Load Register 2
TMR1_CSCTRL	\$1A	Comparator Status and Control Register
		Reserved
TMR2_COMP1	\$20	Compare Register 1
TMR2_COMP2	\$21	Compare Register 2
TMR2_CAPT	\$22	Capture Register
TMR2_LOAD	\$23	Load Register
TMR2_HOLD	\$24	Hold Register
TMR2_CNTR	\$25	Counter Register
TMR2_CTRL	\$26	Control Register
TMR2_SCTRL	\$27	Status and Control Register
TMR2_CMPLD1	\$28	Comparator Load Register 1
TMR2_CMPLD2	\$29	Comparator Load Register 2
TMR2_CSCTRL	\$2A	Comparator Status and Control Register
		Reserved
TMR3_COMP1	\$30	Compare Register 1
TMR3_COMP2	\$31	Compare Register 2
TMR3_CAPT	\$32	Capture Register
TMR3_LOAD	\$33	Load Register
TMR3_HOLD	\$34	Hold Register
TMR3_CNTR	\$35	Counter Register
TMR3_CTRL	\$36	Control Register
TMR3_SCTRL	\$37	Status and Control Register
TMR3_CMPLD1	\$38	Comparator Load Register 1
TMR3_CMPLD2	\$39	Comparator Load Register 2
TMR3_CSCTRL	\$3A	Comparator Status and Control Register

**Table 4-8 Pulse Width Modulator Registers Address Map
(PWM_BASE = \$00 F040)**

Register Acronym	Address Offset	Register Description
PWM_CTRL	\$0	Control Register
PWM_FCTRL	\$1	Fault Control Register
PWM_FLTACK	\$2	Fault Status Acknowledge Register
PWM_OUT	\$3	Output Control Register
PWM_CNTR	\$4	Counter Register
PWM_CMOD	\$5	Counter Modulo Register
PWM_VAL0	\$6	Value Register 0
PWM_VAL1	\$7	Value Register 1
PWM_VAL2	\$8	Value Register 2
PWM_VAL3	\$9	Value Register 3
PWM_VAL4	\$A	Value Register 4
PWM_VAL5	\$B	Value Register 5
PWM_DTIM0	\$C	Dead Time Register 0
PWM_DTIM1	\$D	Dead Time Register 1
PWM_DMAP1	\$E	Disable Mapping Register 1
PWM_DMAP2	\$F	Disable Mapping Register 2
PWM_CNFG	\$10	Configure Register
PWM_CCTRL	\$11	Channel Control Register
PWM_PORT	\$12	Port Register
PWM_ICCTRL	\$13	Internal Correction Control Register
PWM_SCTRL	\$14	Source Control Register

**Table 4-9 Interrupt Control Registers Address Map
(ITCN_BASE = \$00 F060)**

Register Acronym	Address Offset	Register Description
ITCN_IPR0	\$0	Interrupt Priority Register 0
ITCN_IPR1	\$1	Interrupt Priority Register 1
ITCN_IPR2	\$2	Interrupt Priority Register 2
ITCN_IPR3	\$3	Interrupt Priority Register 3
ITCN_IPR4	\$4	Interrupt Priority Register 4
ITCN_VBA	\$5	Vector Base Address Register
ITCN_FIM0	\$6	Fast Interrupt Match 0 Register
ITCN_FIVAL0	\$7	Fast Interrupt Vector Address Low 0 Register
ITCN_FIVAHO	\$8	Fast Interrupt Vector Address High 0 Register

Table 4-9 Interrupt Control Registers Address Map (Continued)
(ITCN_BASE = \$00 F060)

Register Acronym	Address Offset	Register Description
ITCN_FIM1	\$9	Fast Interrupt Match 1 Register
ITCN_FIVAL1	\$A	Fast Interrupt Vector Address Low 1 Register
ITCN_FIVAH1	\$B	Fast Interrupt Vector Address High 1 Register
ITCN_IRQP 0	\$C	IRQ Pending Register 0
ITCN_IRQP 1	\$D	IRQ Pending Register 1
ITCN_IRQP 2	\$E	IRQ Pending Register 2
		Reserved
ITCN_ICTRL	\$12	Interrupt Control Register
		Reserved

Table 4-10 Analog-to-Digital Converter Registers Address Map
(ADC_BASE = \$00 F080)

Register Acronym	Address Offset	Register Description
ADC_CTRL1	\$0	Control Register 1
ADC_CTRL2	\$1	Control Register 2
ADC_ZXCTRL	\$2	Zero Crossing Control Register
ADC_CLIST 1	\$3	Channel List Register 1
ADC_CLIST 2	\$4	Channel List Register 2
ADC_SDIS	\$5	Sample Disable Register
ADC_STAT	\$6	Status Register
ADC_LIMSTAT	\$7	Limit Status Register
ADC_ZXSTAT	\$8	Zero Crossing Status Register
ADC_RSLT0	\$9	Result Register 0
ADC_RSLT1	\$A	Result Register 1
ADC_RSLT2	\$B	Result Register 2
ADC_RSLT3	\$C	Result Register 3
ADC_RSLT4	\$D	Result Register 4
ADC_RSLT5	\$E	Result Register 5
ADC_RSLT6	\$F	Result Register 6
ADC_RSLT7	\$10	Result Register 7
ADC_LOLIM0	\$11	Low Limit Register 0
ADC_LOLIM1	\$12	Low Limit Register 1
ADC_LOLIM2	\$13	Low Limit Register 2
ADC_LOLIM3	\$14	Low Limit Register 3
ADC_LOLIM4	\$15	Low Limit Register 4
ADC_LOLIM5	\$16	Low Limit Register 5

**Table 4-10 Analog-to-Digital Converter Registers Address Map (Continued)
(ADC_BASE = \$00 F080)**

Register Acronym	Address Offset	Register Description
ADC_LOLIM6	\$17	Low Limit Register 6
ADC_LOLIM7	\$18	Low Limit Register 7
ADC_HILIM0	\$19	High Limit Register 0
ADC_HILIM1	\$1A	High Limit Register 1
ADC_HILIM2	\$1B	High Limit Register 2
ADC_HILIM3	\$1C	High Limit Register 3
ADC_HILIM4	\$1D	High Limit Register 4
ADC_HILIM5	\$1E	High Limit Register 5
ADC_HILIM6	\$1F	High Limit Register 6
ADC_HILIM7	\$20	High Limit Register 7
ADC_OFFST0	\$21	Offset Register 0
ADC_OFFST1	\$22	Offset Register 1
ADC_OFFST2	\$23	Offset Register 2
ADC_OFFST3	\$24	Offset Register 3
ADC_OFFST4	\$25	Offset Register 4
ADC_OFFST5	\$26	Offset Register 5
ADC_OFFST6	\$27	Offset Register 6
ADC_OFFST7	\$28	Offset Register 7
ADC_PWR	\$29	Power Control Register
ADC_VREF	\$2A	Voltage Reference Register
		Reserved

**Table 4-11 Serial Communication Interface Registers Address Map
(SCI_BASE = \$00 F0B0)**

Register Acronym	Address Offset	Register Description
SCI_RATE	\$0	Baud Rate Register
SCI_CTRL1	\$1	Control Register 1
SCI_CTRL2	\$2	Control Register 2
SCI_STAT	\$3	Status Register
SCI_DATA	\$4	Data Register

**Table 4-12 Serial Peripheral Interface Registers Address Map
(SPI_BASE = \$00 F0C0)**

Register Acronym	Address Offset	Register Description
SPI_SCTRL	\$0	Status and Control Register
SPI_DSCTRL	\$1	Data Size and Control Register
SPI_DRCV	\$2	Data Receive Register
SPI_DXMIT	\$3	Data Transmit Register

**Table 4-13 I²C Registers Address Map
(I2C_BASE = \$00 F0D0)**

Register Acronym	Address Offset	Register Description
I2C_ADDR	\$0	Address Register
I2C_FDIV	\$1	Frequency Divider Register
I2C_CTRL	\$2	Control Register
I2C_STAT	\$3	Status Register
I2C_DATA	\$4	Data Register
I2C_NFILT	\$5	Noise Filter Register

**Table 4-14 Computer Operating Properly Registers Address Map
(COP_BASE = \$00 F0E0)**

Register Acronym	Address Offset	Register Description
COP_CTRL	\$0	Control Register
COP_TOUT	\$1	Time-Out Register
COP_CNTR	\$2	Counter Register

**Table 4-15 Clock Generation Module Registers Address Map
(OCCS_BASE = \$00 F0F0)**

Register Acronym	Address Offset	Register Description
OCCS_CTRL	\$0	Control Register
OCCS_DIVBY	\$1	Divide-By Register
OCCS_STAT	\$2	Status Register
		Reserved
OCCS_SHUTDN	\$4	Shutdown Register
OCCS_OCTRL	\$5	Oscillator Control Register

**Table 4-16 GPIOA Registers Address Map
(GPIOA_BASE = \$00 F100)**

Register Acronym	Address Offset	Register Description
GPIOA_PUPEN	\$0	Pull-up Enable Register
GPIOA_DATA	\$1	Data Register
GPIOA_DDIR	\$2	Data Direction Register
GPIOA_PEREN	\$3	Peripheral Enable Register
GPIOA_IASSRT	\$4	Interrupt Assert Register
GPIOA_IEN	\$5	Interrupt Enable Register
GPIOA_IEPOL	\$6	Interrupt Edge Polarity Register
GPIOA_IPEND	\$7	Interrupt Pending Register
GPIOA_IEDGE	\$8	Interrupt Edge-Sensitive Register
GPIOA_PPOUTM	\$9	Push-Pull Output Mode Control Register
GPIOA_RDATA	\$A	Raw Data Register
GPIOA_DRIVE	\$B	Drive Strength Control Register

**Table 4-17 GPIOB Registers Address Map
(GPIOB_BASE = \$00 F110)**

Register Acronym	Address Offset	Register Description
GPIOB_PUPEN	\$0	Pull-up Enable Register
GPIOB_DATA	\$1	Data Register
GPIOB_DDIR	\$2	Data Direction Register
GPIOB_PEREN	\$3	Peripheral Enable Register
GPIOB_IASSRT	\$4	Interrupt Assert Register
GPIOB_IEN	\$5	Interrupt Enable Register
GPIOB_IEPOL	\$6	Interrupt Edge Polarity Register
GPIOB_IPEND	\$7	Interrupt Pending Register
GPIOB_IEDGE	\$8	Interrupt Edge-Sensitive Register
GPIOB_PPOUTM	\$9	Push-Pull Output Mode Control Register
GPIOB_RDATA	\$A	Raw Data Register
GPIOB_DRIVE	\$B	Drive Strength Control Register

**Table 4-18 GPIOC Registers Address Map
(GPIOC_BASE = \$00 F120)**

Register Acronym	Address Offset	Register Description
GPIOC_PUPEN	\$0	Pull-up Enable Register
GPIOC_DATA	\$1	Data Register
GPIOC_DDIR	\$2	Data Direction Register
GPIOC_PEREN	\$3	Peripheral Enable Register
GPIOC_IASSRT	\$4	Interrupt Assert Register
GPIOC_IEN	\$5	Interrupt Enable Register
GPIOC_IEPOL	\$6	Interrupt Edge Polarity Register
GPIOC_IPEND	\$7	Interrupt Pending Register
GPIOC_IEDGE	\$8	Interrupt Edge-Sensitive Register
GPIOC_PPOUTM	\$9	Push-Pull Output Mode Control Register
GPIOC_RDATA	\$A	Raw Data Register
GPIOC_DRIVE	\$B	Drive Strength Control Register

**Table 4-19 GPIOD Registers Address Map
(GPIOD_BASE = \$00 F130)**

Register Acronym	Address Offset	Register Description
GPIOD_PUPEN	\$0	Pull-up Enable Register
GPIOD_DATA	\$1	Data Register
GPIOD_DDIR	\$2	Data Direction Register
GPIOD_PEREN	\$3	Peripheral Enable Register
GPIOD_IASSRT	\$4	Interrupt Assert Register
GPIOD_IEN	\$5	Interrupt Enable Register
GPIOD_IEPOL	\$6	Interrupt Edge Polarity Register
GPIOD_IPEND	\$7	Interrupt Pending Register
GPIOD_IEDGE	\$8	Interrupt Edge-Sensitive Register
GPIOD_PPOUTM	\$9	Push-Pull Output Mode Control Register
GPIOD_RDATA	\$A	Raw Data Register
GPIOD_DRIVE	\$B	Drive Strength Control Register

**Table 4-20 System Integration Module Registers Address Map
(SIM_BASE = \$00 F140)**

Register Acronym	Address Offset	Register Description
SIM_CTRL	\$0	Control Register
SIM_RSTAT	\$1	Reset Status Register
SIM_SWC0	\$2	Software Control Register 0
SIM_SWC1	\$3	Software Control Register 1
SIM_SWC2	\$4	Software Control Register 2
SIM_SWC3	\$5	Software Control Register 3
SIM_MSHID	\$6	Most Significant Half JTAG ID
SIM_LSHID	\$7	Least Significant Half JTAG ID
SIM_PWR	\$8	Power Control Register
		Reserved
SIM_CLKOUT	\$A	Clock Out Select Register
SIM_GPS	\$B	GPIO Peripheral Select Register
SIM_PCE	\$C	Peripheral Clock Enable Register
SIM_IOSAHI	\$D	I/O Short Address Location High Register
SIM_IOSALO	\$E	I/O Short Address Location Low Register

**Table 4-21 Power Supervisor Registers Address Map
(PS_BASE = \$00 F160)**

Register Acronym	Address Offset	Register Description
PS_CTRL	\$0	Control Register
PS_STAT	\$1	Status Register

**Table 4-22 Flash Module Registers Address Map
(FM_BASE = \$00 F400)**

Register Acronym	Address Offset	Register Description
FM_CLKDIV	\$0	Clock Divider Register
FM_CNFG	\$1	Configuration Register
	\$2	Reserved
FM_SECHI	\$3	Security High Half Register
FM_SECLO	\$4	Security Low Half Register
	\$5 - \$9	Reserved
FM_PROT	\$10	Protection Register
	\$11 - \$12	Reserved

Table 4-22 Flash Module Registers Address Map (Continued)
(FM_BASE = \$00 F400)

Register Acronym	Address Offset	Register Description
FM_USTAT	\$13	User Status Register
FM_CMD	\$14	Command Register
	\$15	Reserved
	\$16	Reserved
	\$17	Reserved
FM_DATA	\$18	Data Buffer Register
	\$19	Reserved
	\$1A	Reserved
FM_OPT1	\$1B	Optional Data 1 Register
		Reserved
FM_TSTSIG	\$1D	Test Array Signature Register

Part 5 Interrupt Controller (ITCN)

5.1 Introduction

The Interrupt Controller (ITCN) module is used to arbitrate between various interrupt requests (IRQs), to signal to the 56800E core when an interrupt of sufficient priority exists, and to what address to jump in order to service this interrupt.

5.2 Features

The ITCN module design includes these distinctive features:

- Programmable priority levels for each IRQ
- Two programmable Fast Interrupts
- Notification to SIM module to restart clocks out of Wait and Stop modes
- Ability to drive initial address on the address bus after reset

For further information, see [Table 4-2](#), Interrupt Vector Table Contents.

5.3 Functional Description

The Interrupt Controller contains registers that allow each of the 46 interrupt sources to be set to one of three priority levels (excluding certain interrupts that are of fixed priority). Next, all of the interrupt requests of a given level are priority encoded to determine the lowest numerical value of the active interrupt requests for that level. Within a given priority level, number 0 is the highest priority and number 45 is the lowest.

During wait and stop modes, the system clocks and the 56800E core are turned off. The ITCN can wake the core and restart system clocks by signaling a pending IRQ to the System Integration Module (SIM) to

restart the clocks and service the IRQ. An IRQ can only wake the core if the IRQ is enabled prior to entering wait or stop mode.

5.3.1 Normal Interrupt Handling

Once the INTC has determined that an interrupt is to be serviced and which interrupt has the highest priority, an interrupt vector address is generated. Normal interrupt handling concatenates the Vector Base Address (VBA) and the vector number to determine the vector address, generating an offset into the vector table for each interrupt.

5.3.2 Interrupt Nesting

Interrupt exceptions may be nested to allow an IRQ of higher priority than the current exception to be serviced. The following table defines the nesting requirements for each priority level.

Table 5-1 Interrupt Mask Bit Definition

SR[9]	SR[8]	Exceptions Permitted	Exceptions Masked
0	0	Priorities 0, 1, 2, 3	None
0	1	Priorities 1, 2, 3	Priority 0
1	0	Priorities 2, 3	Priorities 0, 1
1	1	Priority 3	Priorities 0, 1, 2

5.3.3 Fast Interrupt Handling

Fast interrupts are described in the **DSP56800E Reference Manual**. The interrupt controller recognizes Fast Interrupts before the core does.

A Fast Interrupt is defined (to the ITCN) by:

1. Setting the priority of the interrupt as level 2, with the appropriate field in the IPR registers
2. Setting the FIM n register to the appropriate vector number
3. Setting the FIVAL n and FIVAH n registers with the address of the code for the Fast Interrupt

When an interrupt occurs, its vector number is compared with the FIM0 and FIM1 register values. If a match occurs, and it is a level 2 interrupt, the ITCN handles it as a Fast Interrupt. The ITCN takes the vector address from the appropriate FIVAL n and FIVAH n registers, instead of generating an address that is an offset from the VBA.

The core then fetches the instruction from the indicated vector address and if it is not a JSR, the core starts its Fast Interrupt handling.

5.4 Block Diagram

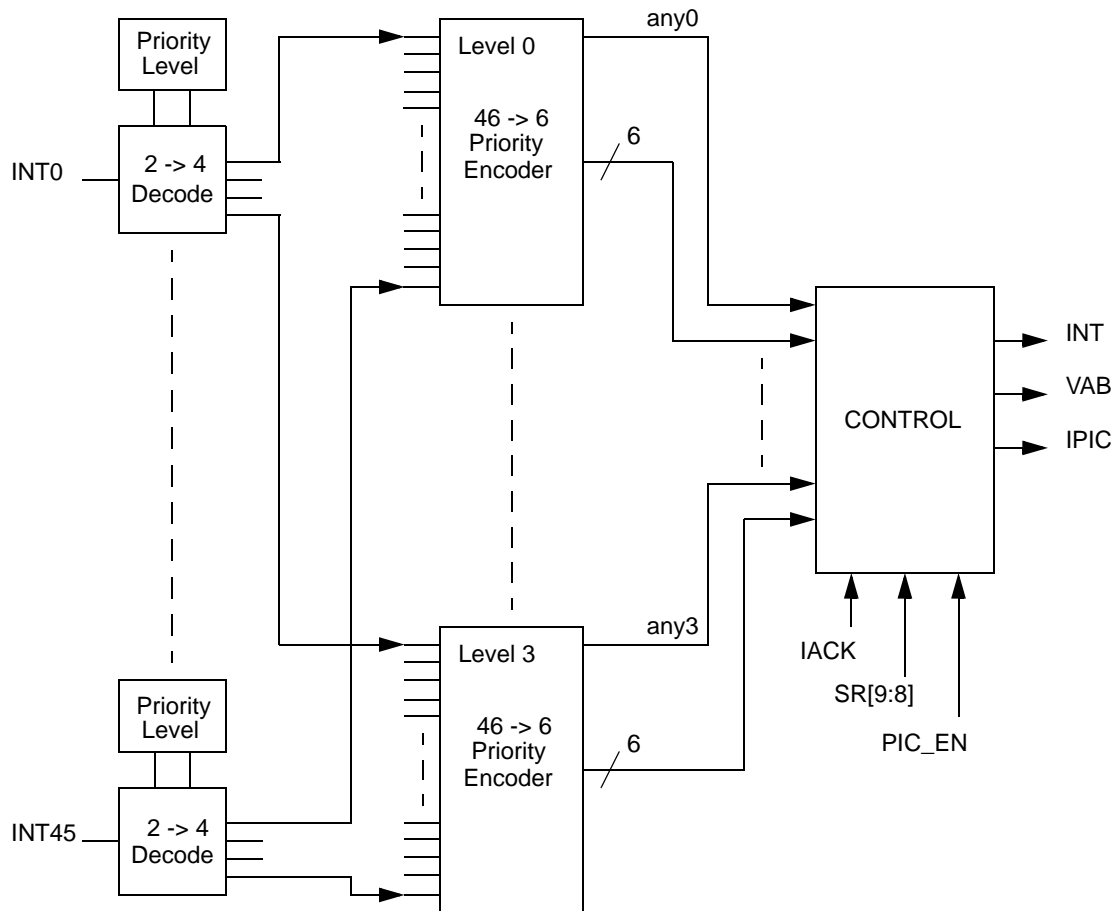

Figure 5-1 Interrupt Controller Block Diagram

5.5 Register Descriptions

A register address is the sum of a base address and an address offset. The base address is defined at the system level and the address offset is defined at the module level. The ITCN module has 16 registers.

Table 5-2 ITCN Register Summary
(ITCN_BASE = \$00 F060)

Register Acronym	Base Address +	Register Name	Section Location
IPR0	\$0	Interrupt Priority Register 0	5.5.1
IPR1	\$1	Interrupt Priority Register 1	5.5.2
IPR2	\$2	Interrupt Priority Register 2	5.5.3

Table 5-2 ITCN Register Summary (Continued)
(ITCN_BASE = \$00 F060)

Register Acronym	Base Address +	Register Name	Section Location
IPR3	\$3	Interrupt Priority Register 3	5.5.4
IPR4	\$4	Interrupt Priority Register 4	5.5.5
VBA	\$5	Vector Base Address Register	5.5.6
FIM0	\$6	Fast Interrupt Match 0 Register	5.5.7
FIVAL0	\$7	Fast Interrupt 0 Vector Address Low Register	5.5.8
FIVAH0	\$8	Fast Interrupt 0 Vector Address High Register	5.5.9
FIM1	\$9	Fast Interrupt Match 1 Register	5.5.10
FIVAL1	\$A	Fast Interrupt 1 Vector Address Low Register	5.5.11
FIVAH1	\$B	Fast Interrupt 1 Vector Address High Register	5.5.12
IRQP0	\$C	IRQ Pending Register 0	5.5.13
IRQP1	\$D	IRQ Pending Register 1	5.5.14
IRQP2	\$E	IRQ Pending Register 2	5.5.15
		Reserved	
ICTRL	\$12	Interrupt Control Register	5.5.16
		Reserved	

Add. Offset	Register Name		15	14	13	12	11	10	9	8	7	6	5	4	3	2	1	0	
\$0	IPR0	R	LVI IPL		0	0	0	0	RX_REG IPL		TX_REG IPL		TRBUF IPL		BKPT_U IPL		STPCNT IPL		
		W																	
\$1	IPR1	R	GPIOB IPL		GPIOC IPL		GPIOD IPL		0	0	FM_CBE IPL		FM_CC IPL		FM_ERR IPL		PLL IPL		
		W																	
\$2	IPR2	R	SCI_RCV IPL		SCI_RERR IPL		0	0	SCI_TIDL IPL		SCI_XMIT IPL		SPL_XMIT IPL		SPL_RCV IPL		GPIOA IPL		
		W																	
\$3	IPR3	R	ADCA_CC IPL		TMR_3 IPL		TMR_2 IPL		TMR_1 IPL		TMR_0 IPL		I2C_ADDR IPL		0	0	0	0	
		W																	
\$4	IPR4	R	0	0	0	0	0	0	0	0	PWM_F IPL		PWM_RL IPL		ADC_ZC_LE IPL		ADCB_CC IPL		
		W																	
\$5	VBA	R	0	0	VECTOR_BASE_ADDRESS														
		W																	
\$6	FIM0	R	0	0	0	0	0	0	0	0	0	0	FAST INTERRUPT 0						
		W																	
\$7	FIVAL0	R	FAST INTERRUPT 0 VECTOR ADDRESS LOW																
		W																	
\$8	FIVAH0	R	0	0	0	0	0	0	0	0	0	0	0	FAST INTERRUPT 0 VECTOR ADDRESS HIGH					
		W																	
\$9	FIM1	R	0	0	0	0	0	0	0	0	0	0	FAST INTERRUPT 1						
		W																	
\$A	FIVAL1	R	FAST INTERRUPT 1 VECTOR ADDRESS LOW																
		W																	
\$B	FIVAH1	R	0	0	0	0	0	0	0	0	0	0	FAST INTERRUPT 1 VECTOR ADDRESS HIGH						
		W																	
\$C	IRQP0	R	PENDING[16:2]															1	
		W																	
\$D	IRQP1	R	PENDING[32:17]																
		W																	
\$E	IRQP2	R	1	1	1	PENDING[45:33]													
		W																	
	Reserved																		
\$12	ICTRL	R	INT	IPIC	VAB								INT_DIS	1	1	1	0	0	
		W																	
	Reserved																		

= Reserved

Figure 5-2 ITCN Register Map Summary

5.5.1 Interrupt Priority Register 0 (IPR0)

Base + \$0	15	14	13	12	11	10	9	8	7	6	5	4	3	2	1	0
Read	LVI IPL		0	0	0	0	RX_REG IPL		TX_REG IPL		TRBUF IPL		BKPT_U IPL		STPCNT IPL	
Write																
RESET	0	0	0	0	0	0	0	0	0	0	0	0	0	0	0	0

Figure 5-3 Interrupt Priority Register 0 (IPR0)

5.5.1.1 LVI IPL—Bits 15–14

This field is used to set the interrupt priority levels for a peripheral IRQ. This IRQ is limited to priorities 0 through 2 and is disabled by default.

- 00 = IRQ disabled (default)
- 01 = IRQ is priority level 0
- 10 = IRQ is priority level 1
- 11 = IRQ is priority level 2

5.5.1.2 Reserved—Bits 13–10

This bit field is reserved or not implemented. It is read as 0 and cannot be modified by writing.

5.5.1.3 EOnCE Receive Register Full Interrupt Priority Level (RX_REG IPL)— Bits 9–8

This field is used to set the interrupt priority level for IRQs. This IRQ is limited to priorities 1 through 3. It is disabled by default.

- 00 = IRQ disabled (default)
- 01 = IRQ is priority level 1
- 10 = IRQ is priority level 2
- 11 = IRQ is priority level 3

5.5.1.4 EOnCE Transmit Register Empty Interrupt Priority Level (TX_REG IPL)— Bits 7–6

This field is used to set the interrupt priority level for IRQs. This IRQ is limited to priorities 1 through 3. It is disabled by default.

- 00 = IRQ disabled (default)
- 01 = IRQ is priority level 1
- 10 = IRQ is priority level 2
- 11 = IRQ is priority level 3

5.5.1.5 EOnCE Trace Buffer Interrupt Priority Level (TRBUF IPL)— Bits 5–4

This field is used to set the interrupt priority level for IRQs. This IRQ is limited to priorities 1 through 3. It is disabled by default.

- 00 = IRQ disabled (default)
- 01 = IRQ is priority level 1
- 10 = IRQ is priority level 2
- 11 = IRQ is priority level 3

5.5.1.6 EOnCE Breakpoint Unit Interrupt Priority Level (BKPT_U IPL)— Bits 3–2

This field is used to set the interrupt priority level for IRQs. This IRQ is limited to priorities 1 through 3. It is disabled by default.

- 00 = IRQ disabled (default)
- 01 = IRQ is priority level 1
- 10 = IRQ is priority level 2
- 11 = IRQ is priority level 3

5.5.1.7 EOnCE Step Counter Interrupt Priority Level (STPCNT IPL)— Bits 1–0

This field is used to set the interrupt priority level for IRQs. This IRQ is limited to priorities 1 through 3. It is disabled by default.

- 00 = IRQ disabled (default)
- 01 = IRQ is priority level 1
- 10 = IRQ is priority level 2
- 11 = IRQ is priority level 3

5.5.2 Interrupt Priority Register 1 (IPR1)

Base + \$1	15	14	13	12	11	10	9	8	7	6	5	4	3	2	1	0
Read	GPIOB IPL		GPIOC IPL		GPIOD IPL		0	0	FM_CBE IPL		FM_CC IPL		FM_ERR IPL		PLL IPL	
Write																
RESET	0	0	0	0	0	0	0	0	0	0	0	0	0	0	0	0

Figure 5-4 Interrupt Priority Register 1 (IPR1)

5.5.2.1 GPIOB Interrupt Priority Level (GPIOB IPL)—Bits 15–14

This field is used to set the interrupt priority level for IRQs. This IRQ is limited to priorities 0 through 2. It is disabled by default.

- 00 = IRQ disabled (default)
- 01 = IRQ is priority level 0
- 10 = IRQ is priority level 1
- 11 = IRQ is priority level 2

5.5.2.2 GPIOC Interrupt Priority Level (GPIOC IPL)—Bits 13–12

This field is used to set the interrupt priority level for IRQs. This IRQ is limited to priorities 0 through 2. It is disabled by default.

- 00 = IRQ disabled (default)
- 01 = IRQ is priority level 0
- 10 = IRQ is priority level 1
- 11 = IRQ is priority level 2

5.5.2.3 GPIOD Interrupt Priority Level (GPIOD IPL)—Bits 11–10

This field is used to set the interrupt priority level for IRQs. This IRQ is limited to priorities 0 through 2. It is disabled by default.

- 00 = IRQ disabled (default)
- 01 = IRQ is priority level 0
- 10 = IRQ is priority level 1
- 11 = IRQ is priority level 2

5.5.2.4 Reserved—Bits 9–8

This bit field is reserved or not implemented. It is read as 0 and cannot be modified by writing.

5.5.2.5 FM Command, Data, Address Buffers Empty Interrupt Priority Level (FM_CBE IPL)—Bits 7–6

This field is used to set the interrupt priority level for IRQs. This IRQ is limited to priorities 0 through 2. It is disabled by default.

- 00 = IRQ disabled (default)
- 01 = IRQ is priority level 0
- 10 = IRQ is priority level 1
- 11 = IRQ is priority level 2

5.5.2.6 FM Command Complete Priority Level (FM_CC IPL)—Bits 5–4

This field is used to set the interrupt priority level for IRQs. This IRQ is limited to priorities 0 through 2. It is disabled by default.

- 00 = IRQ disabled (default)
- 01 = IRQ is priority level 0
- 10 = IRQ is priority level 1
- 11 = IRQ is priority level 2

5.5.2.7 FM Error Interrupt Priority Level (FM_ERR IPL)—Bits 3–2

This field is used to set the interrupt priority level for IRQs. This IRQ is limited to priorities 0 through 2. It is disabled by default.

- 00 = IRQ disabled (default)
- 01 = IRQ is priority level 0
- 10 = IRQ is priority level 1
- 11 = IRQ is priority level 2

5.5.2.8 PLL Loss of Reference or Change in Lock Status Interrupt Priority Level (PLL IPL)—Bits 1–0

This field is used to set the interrupt priority level for IRQs. This IRQ is limited to priorities 0 through 2. It is disabled by default.

- 00 = IRQ disabled (default)
- 01 = IRQ is priority level 0
- 10 = IRQ is priority level 1
- 11 = IRQ is priority level 2

5.5.3 Interrupt Priority Register 2 (IPR2)

Base + \$2	15	14	13	12	11	10	9	8	7	6	5	4	3	2	1	0
Read	SCI_RCV IPL		SCI_RERR IPL		0	0	SCI_TIDL IPL		SCI_XMIT IPL		SPI_XMIT IPL		SPI_RCV IPL		GPIOA IPL	
Write																
RESET	0	0	0	0	0	0	0	0	0	0	0	0	0	0	0	0

Figure 5-5 Interrupt Priority Register 2 (IPR2)

5.5.3.1 SCI Receiver Full Interrupt Priority Level (SCI_RCV IPL)—Bits 15–14

This field is used to set the interrupt priority level for IRQs. This IRQ is limited to priorities 0 through 2. It is disabled by default.

- 00 = IRQ disabled (default)
- 01 = IRQ is priority level 0
- 10 = IRQ is priority level 1
- 11 = IRQ is priority level 2

5.5.3.2 SCI Receiver Error Interrupt Priority Level (SCI_RERR IPL)—Bits 13–12

This field is used to set the interrupt priority level for IRQs. This IRQ is limited to priorities 0 through 2. It is disabled by default.

- 00 = IRQ disabled (default)
- 01 = IRQ is priority level 0
- 10 = IRQ is priority level 1
- 11 = IRQ is priority level 2

5.5.3.3 Reserved—Bits 11–10

This bit field is reserved or not implemented. It is read as 0 and cannot be modified by writing.

5.5.3.4 SCI Transmitter Idle Interrupt Priority Level (SCI_TIDL IPL)— Bits 9–8

This field is used to set the interrupt priority level for IRQs. This IRQ is limited to priorities 0 through 2. It is disabled by default.

- 00 = IRQ disabled (default)
- 01 = IRQ is priority level 0
- 10 = IRQ is priority level 1
- 11 = IRQ is priority level 2

5.5.3.5 SCI Transmitter Empty Interrupt Priority Level (SCI_XMIT IPL)— Bits 7–6

This field is used to set the interrupt priority level for IRQs. This IRQ is limited to priorities 0 through 2. It is disabled by default.

- 00 = IRQ disabled (default)
- 01 = IRQ is priority level 0
- 10 = IRQ is priority level 1
- 11 = IRQ is priority level 2

5.5.3.6 SPI Transmitter Empty Interrupt Priority Level (SPI_XMIT IPL)— Bits 5–4

This field is used to set the interrupt priority level for IRQs. This IRQ is limited to priorities 0 through 2. It is disabled by default.

- 00 = IRQ disabled (default)
- 01 = IRQ is priority level 0
- 10 = IRQ is priority level 1
- 11 = IRQ is priority level 2

5.5.3.7 SPI Receiver Full Interrupt Priority Level (SPI_RCV IPL)— Bits 3–2

This field is used to set the interrupt priority level for IRQs. This IRQ is limited to priorities 0 through 2. It is disabled by default.

- 00 = IRQ disabled (default)
- 01 = IRQ is priority level 0
- 10 = IRQ is priority level 1
- 11 = IRQ is priority level 2

5.5.3.8 GPIOA Interrupt Priority Level (GPIOA IPL)—Bits 1–0

This field is used to set the interrupt priority level for IRQs. This IRQ is limited to priorities 0 through 2. It is disabled by default.

- 00 = IRQ disabled (default)
- 01 = IRQ is priority level 0
- 10 = IRQ is priority level 1
- 11 = IRQ is priority level 2

5.5.4 Interrupt Priority Register 3 (IPR3)

Base + \$3	15	14	13	12	11	10	9	8	7	6	5	4	3	2	1	0
Read	ADCA_CC IPL		TMR_3 IPL		TMR_2 IPL		TMR_1 IPL		TMR_0 IPL		I2C_ADDR IPL		0	0	0	0
Write																
RESET	0	0	0	0	0	0	0	0	0	0	0	0	0	0	0	0

Figure 5-6 Interrupt Priority Register 3 (IPR3)

5.5.4.1 ADCA Conversion Complete Interrupt Priority Level (ADCA_CC IPL)—Bits 15–14

This field is used to set the interrupt priority level for IRQs. This IRQ is limited to priorities 0 through 2. They are disabled by default.

- 00 = IRQ disabled (default)
- 01 = IRQ is priority level 0
- 10 = IRQ is priority level 1
- 11 = IRQ is priority level 2

5.5.4.2 Timer Channel 3 Interrupt Priority Level (TMR_3 IPL)—Bits 13–12

This field is used to set the interrupt priority level for IRQs. This IRQ is limited to priorities 0 through 2. They are disabled by default.

- 00 = IRQ disabled (default)
- 01 = IRQ is priority level 0
- 10 = IRQ is priority level 1
- 11 = IRQ is priority level 2

5.5.4.3 Timer Channel 2 Interrupt Priority Level (TMR_2 IPL)—Bits 11–10

This field is used to set the interrupt priority level for IRQs. This IRQ is limited to priorities 0 through 2. They are disabled by default.

- 00 = IRQ disabled (default)
- 01 = IRQ is priority level 0
- 10 = IRQ is priority level 1
- 11 = IRQ is priority level 2

5.5.4.4 Timer Channel 1 Interrupt Priority Level (TMR_1 IPL)—Bits 9–8

This field is used to set the interrupt priority level for IRQs. This IRQ is limited to priorities 0 through 2. They are disabled by default.

- 00 = IRQ disabled (default)
- 01 = IRQ is priority level 0
- 10 = IRQ is priority level 1
- 11 = IRQ is priority level 2

5.5.4.5 Timer Channel 0 Interrupt Priority Level (TMR_0 IPL)—Bits 7–6

This field is used to set the interrupt priority level for IRQs. This IRQ is limited to priorities 0 through 2. They are disabled by default.

- 00 = IRQ disabled (default)
- 01 = IRQ is priority level 0
- 10 = IRQ is priority level 1
- 11 = IRQ is priority level 2

5.5.4.6 I²C Address Detect Interrupt Priority Level (I2C_ADDR IPL)—Bits 5–4

This field is used to set the interrupt priority level for IRQs. This IRQ is limited to priorities 0 through 2. They are disabled by default.

- 00 = IRQ disabled (default)
- 01 = IRQ is priority level 0
- 10 = IRQ is priority level 1
- 11 = IRQ is priority level 2

5.5.4.7 Reserved—Bits 3–0

This bit field is reserved or not implemented. It is read as 0 and cannot be modified by writing.

5.5.5 Interrupt Priority Register 4 (IPR4)

Base + \$4	15	14	13	12	11	10	9	8	7	6	5	4	3	2	1	0
Read	0	0	0	0	0	0	0	0	PWM_F IPL		PWM_RL IPL		ADC_ZC_LE IPL		ADCB_CC IPL	
Write																
RESET	0	0	0	0	0	0	0	0	0	0	0	0	0	0	0	0

Figure 5-7 Interrupt Priority Register 4 (IPR4)

5.5.5.1 Reserved—Bits 15–8

This bit field is reserved or not implemented. It is read as 0 and cannot be modified by writing.

5.5.5.2 PWM Fault Interrupt Priority Level (PWM_F IPL)— Bits 7–6

This field is used to set the interrupt priority level for IRQs. This IRQ is limited to priorities 0 through 2. They are disabled by default.

- 00 = IRQ disabled (default)
- 01 = IRQ is priority level 0
- 10 = IRQ is priority level 1
- 11 = IRQ is priority level 2

5.5.5.3 Reload PWM Interrupt Priority Level (PWM_RL IPL)— Bits 5–4

This field is used to set the interrupt priority level for IRQs. This IRQ is limited to priorities 0 through 2. They are disabled by default.

- 00 = IRQ disabled (default)
- 01 = IRQ is priority level 0
- 10 = IRQ is priority level 1
- 11 = IRQ is priority level 2

5.5.5.4 ADC Zero Crossing or Limit Error Interrupt Priority Level (ADC_ZC_LE IPL)— Bits 3–2

This field is used to set the interrupt priority level for IRQs. This IRQ is limited to priorities 0 through 2. They are disabled by default.

- 00 = IRQ disabled (default)
- 01 = IRQ is priority level 0
- 10 = IRQ is priority level 1
- 11 = IRQ is priority level 2

5.5.5.5 ADCB Conversion Complete Interrupt Priority Level (ADCB_CC IPL)—Bits 1–0

This field is used to set the interrupt priority level for IRQs. This IRQ is limited to priorities 0 through 2. They are disabled by default.

- 00 = IRQ disabled (default)
- 01 = IRQ is priority level 0
- 10 = IRQ is priority level 1
- 11 = IRQ is priority level 2

5.5.6 Vector Base Address Register (VBA)

Base + \$5	15	14	13	12	11	10	9	8	7	6	5	4	3	2	1	0
Read	0	0	VECTOR_BASE_ADDRESS													
Write																
RESET ¹	0	0	0	0	0	0	0	0	0	0	0	0	0	0	0	0

1. The 56F8014 resets to a value of 0x0000. This corresponds to reset addresses of 0x00 0000.

Figure 5-8 Vector Base Address Register (VBA)

5.5.6.1 Reserved—Bits15—14

This bit field is reserved or not implemented. It is read as 0 and cannot be modified by writing.

5.5.6.2 Vector Address Bus (VAB)—Bits 13—0

The value in this register is used as the upper 14 bits of the interrupt vector VAB[20:0]. The lower 7 bits are determined based on the highest priority interrupt and are then appended onto VBA before presenting the full VAB to the Core.

5.5.7 Fast Interrupt Match 0 Register (FIM0)

Base + \$6	15	14	13	12	11	10	9	8	7	6	5	4	3	2	1	0
Read	0	0	0	0	0	0	0	0	0	0	FAST INTERRUPT 0					
Write																
RESET	0	0	0	0	0	0	0	0	0	0	0	0	0	0	0	0

Figure 5-9 Fast Interrupt Match 0 Register (FIM0)

5.5.7.1 Reserved—Bits 15–6

This bit field is reserved or not implemented. It is read as 0 and cannot be modified by writing.

5.5.7.2 Fast Interrupt 0 Vector Number (FAST INTERRUPT 0)—Bits 5–0

These values determine which IRQ will be Fast Interrupt 0. Fast Interrupts vector directly to a service routine based on values in the Fast Interrupt Vector Address registers without having to go to a jump table first. IRQs used as Fast Interrupts *must* be set to priority level 2. Unexpected results will occur if a Fast Interrupt vector is set to any other priority. A Fast Interrupt automatically becomes the highest-priority level 2 interrupt regardless of its location in the interrupt table prior to being declared as Fast Interrupt. Fast Interrupt 0 has priority over fast Interrupt 1. To determine the vector number of each IRQ, refer to the vector table.

5.5.8 Fast Interrupt 0 Vector Address Low Register (FIVAL0)

Base + \$7	15	14	13	12	11	10	9	8	7	6	5	4	3	2	1	0
Read	FAST INTERRUPT 0 VECTOR ADDRESS LOW															
Write	FAST INTERRUPT 0 VECTOR ADDRESS LOW															
RESET	0	0	0	0	0	0	0	0	0	0	0	0	0	0	0	0

Figure 5-10 Fast Interrupt 0 Vector Address Low Register (FIVAL0)

5.5.8.1 Fast Interrupt 0 Vector Address Low (FIVAL0)—Bits 15—0

The lower 16 bits of the vector address used for Fast Interrupt 0. This register is combined with FIVAH0 to form the 21-bit vector address for Fast Interrupt 0 defined in the FIM0 register.

5.5.9 Fast Interrupt 0 Vector Address High Register (FIVAH0)

Base + \$8	15	14	13	12	11	10	9	8	7	6	5	4	3	2	1	0
Read	0	0	0	0	0	0	0	0	0	0	0	FAST INTERRUPT 0 VECTOR ADDRESS HIGH				
Write												FAST INTERRUPT 0 VECTOR ADDRESS HIGH				
RESET	0	0	0	0	0	0	0	0	0	0	0	0	0	0	0	0

Figure 5-11 Fast Interrupt 0 Vector Address High Register (FIVAH0)

5.5.9.1 Reserved—Bits 15—5

This bit field is reserved or not implemented. It is read as 0 and cannot be modified by writing.

5.5.9.2 Fast Interrupt 0 Vector Address High (FIVAH0)—Bits 4—0

The upper five bits of the vector address used for Fast Interrupt 0. This register is combined with FIVAL0 to form the 21-bit vector address for Fast Interrupt 0 defined in the FIM0 register.

5.5.10 Fast Interrupt 1 Match Register (FIM1)

Base + \$9	15	14	13	12	11	10	9	8	7	6	5	4	3	2	1	0
Read	0	0	0	0	0	0	0	0	0	0	FAST INTERRUPT 1					
Write											FAST INTERRUPT 1					
RESET	0	0	0	0	0	0	0	0	0	0	0	0	0	0	0	0

Figure 5-12 Fast Interrupt 1 Match Register (FIM1)

5.5.10.1 Reserved—Bits 15—6

This bit field is reserved or not implemented. It is read as 0 and cannot be modified by writing.

5.5.10.2 Fast Interrupt 1 Vector Number (FAST INTERRUPT 1)—Bits 5—0

These values determine which IRQ will be Fast Interrupt 1. Fast Interrupts vector directly to a service routine based on values in the Fast Interrupt Vector Address registers without having to go to a jump table first. IRQs used as Fast Interrupts *must* be set to priority level 2. Unexpected results will occur if a Fast

Interrupt vector is set to any other priority. A Fast Interrupt automatically becomes the highest-priority level 2 interrupt regardless of its location in the interrupt table prior to being declared as Fast Interrupt. Fast Interrupt 0 has priority over Fast Interrupt 1. To determine the vector number of each IRQ, refer to the vector table.

5.5.11 Fast Interrupt 1 Vector Address Low Register (FIVAL1)

Base + \$A	15	14	13	12	11	10	9	8	7	6	5	4	3	2	1	0
Read	FAST INTERRUPT 1 VECTOR ADDRESS LOW															
Write																
RESET	0	0	0	0	0	0	0	0	0	0	0	0	0	0	0	0

Figure 5-13 Fast Interrupt 1 Vector Address Low Register (FIVAL1)

5.5.11.1 Fast Interrupt 1 Vector Address Low (FIVAL1)—Bits 15–0

The lower 16 bits of the vector address used for Fast Interrupt 1. This register is combined with FIVAH1 to form the 21-bit vector address for Fast Interrupt 1 defined in the FIM1 register.

5.5.12 Fast Interrupt 1 Vector Address High Register (FIVAH1)

Base + \$B	15	14	13	12	11	10	9	8	7	6	5	4	3	2	1	0
Read	0	0	0	0	0	0	0	0	0	0	0	FAST INTERRUPT 1 VECTOR ADDRESS HIGH				
Write																
RESET	0	0	0	0	0	0	0	0	0	0	0	0	0	0	0	0

Figure 5-14 Fast Interrupt 1 Vector Address High Register (FIVAH1)

5.5.12.1 Reserved—Bits 15–5

This bit field is reserved or not implemented. It is read as 0 and cannot be modified by writing.

5.5.12.2 Fast Interrupt 1 Vector Address High (FIVAH1)—Bits 4–0

The upper five bits of the vector address are used for Fast Interrupt 1. This register is combined with FIVAL1 to form the 21-bit vector address for Fast Interrupt 1 defined in the FIM1 register.

5.5.13 IRQ Pending Register 0 (IRQP0)

Base + \$C	15	14	13	12	11	10	9	8	7	6	5	4	3	2	1	0
Read	PENDING[16:2]															1
Write																
RESET	1	1	1	1	1	1	1	1	1	1	1	1	1	1	1	1

Figure 5-15 IRQ Pending Register 0 (IRQP0)

5.5.13.1 IRQ Pending (PENDING)—Bits 15–1

This register combines with IRQP1 and IRQP2 to represent the pending IRQs for interrupt vector numbers 2 through 45.

- 0 = IRQ pending for this vector number
- 1 = No IRQ pending for this vector number

5.5.13.2 Reserved—Bit 0

This bit is reserved or not implemented. It is read as 1 and cannot be modified by writing.

5.5.14 IRQ Pending Register 1 (IRQP1)

Base + \$D	15	14	13	12	11	10	9	8	7	6	5	4	3	2	1	0
Read	PENDING[32:17]															
Write																
RESET	1	1	1	1	1	1	1	1	1	1	1	1	1	1	1	1

Figure 5-16 IRQ Pending Register 1 (IRQP1)

5.5.14.1 IRQ Pending (PENDING)—Bits 32–17

This register combines with IRQP0 and IRQP2 to represent the pending IRQs for interrupt vector numbers 2 through 45.

- 0 = IRQ pending for this vector number
- 1 = No IRQ pending for this vector number

5.5.15 IRQ Pending Register 2 (IRQP2)

Base + \$E	15	14	13	12	11	10	9	8	7	6	5	4	3	2	1	0
Read	1	1	1	PENDING[45:33]												
Write																
RESET	1	1	1	1	1	1	1	1	1	1	1	1	1	1	1	1

Figure 5-17 IRQ Pending Register 2 (IRQP2)

5.5.15.1 IRQ Pending (PENDING)—Bits 45–33

This register combines with IRQP0 and IRQP1 to represent the pending IRQs for interrupt vector numbers 2 through 45.

- 0 = IRQ pending for this vector number
- 1 = No IRQ pending for this vector number

5.5.16 Interrupt Control Register (ICTRL)

\$Base + \$12	15	14	13	12	11	10	9	8	7	6	5	4	3	2	1	0
Read	INT	IPIC		VAB							INT_ DIS	1	1	1	0	0
Write																
RESET	0	0	0	0	0	0	0	0	0	0	0	1	1	1	0	0

Figure 5-18 Interrupt Control Register (ICTRL)

5.5.16.1 Interrupt (INT)—Bit 15

This *read-only* bit reflects the state of the interrupt to the 56800E core.

- 0 = No interrupt is being sent to the 56800E core
- 1 = An interrupt is being sent to the 56800E core

5.5.16.2 Interrupt Priority Level (IPIC)—Bits 14–13

These *read-only* bits reflect the state of the new interrupt priority level bits being presented to the 56800E core. These bits indicate the priority level needed for a new IRQ to interrupt the current interrupt being sent to the 56800E core. This field is only updated when the 56800E core jumps to a new interrupt service routine.

Note: Nested interrupts may cause this field to be updated before the original interrupt service routine can read it.

- 00 = Required nested exception priority levels are 0, 1, 2, or 3
- 01 = Required nested exception priority levels are 1, 2, or 3
- 10 = Required nested exception priority levels are 2 or 3
- 11 = Required nested exception priority level is 3

Table 5-3 Interrupt Priority Encoding

IPIC_VALUE[1:0]	Current Interrupt Priority Level	Required Nested Exception Priority
00	No interrupt or SWILP	Priorities 0, 1, 2, 3
01	Priority 0	Priorities 1, 2, 3
10	Priority 1	Priorities 2, 3
11	Priority 2 or 3	Priority 3

5.5.16.3 Vector Number - Vector Address Bus (VAB)—Bits 12–6

This *read-only* field shows the vector number (VAB[6:0]) used at the time the last IRQ was taken. In the case of a Fast Interrupt, it shows the lower address bits of the jump address. This field is only updated when the 56800E core jumps to a new interrupt service routine.

Note: Nested interrupts may cause this field to be updated before the original interrupt service routine can read it.

5.5.16.4 Interrupt Disable (INT_DIS)—Bit 5

This bit allows all interrupts to be disabled.

- 0 = Normal operation (default)
- 1 = All interrupts disabled

5.5.16.5 Reserved—Bits 4–2

This bit field is reserved or not implemented. It is read as 1 and cannot be modified by writing.

5.5.16.6 Reserved—Bits 1–0

This bit field is reserved or not implemented. It is read as 0 and cannot be modified by writing.

5.6 Resets

5.6.1 General

Table 5-4 Reset Summary

Reset	Priority	Source	Characteristics
Core Reset		RST	Core reset from the SIM

5.6.2 Description of Reset Operation

5.6.2.1 Reset Handshake Timing

The ITCN provides the 56800E core with a reset vector address on the VAB pins whenever $\overline{\text{RESET}}$ is asserted from the SIM. The reset vector will be presented until the second rising clock edge after $\overline{\text{RESET}}$ is released. The general timing is shown in [Figure 5-19](#).

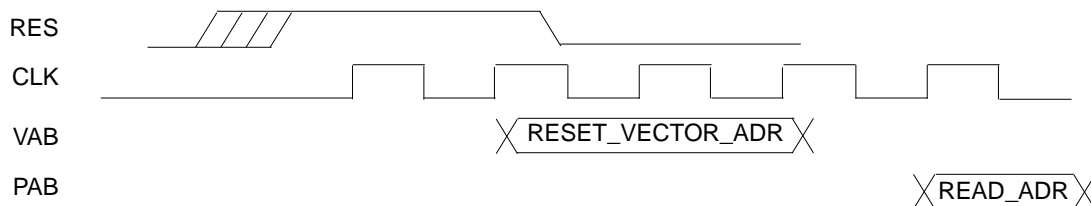

Figure 5-19 Reset Interface

5.6.3 ITCN After Reset

After reset, all of the ITCN registers are in their default states. This means all interrupts are disabled, except the core IRQs with fixed priorities:

- Illegal Instruction
- SW Interrupt 3
- HW Stack Overflow
- Misaligned Long Word Access
- SW Interrupt 2
- SW Interrupt 1



- SW Interrupt 0
- SW Interrupt LP

These interrupts are enabled at their fixed priority levels.

Part 6 System Integration Module (SIM)

6.1 Introduction

The SIM module is a system catchall for the glue logic that ties together the system-on-chip. It controls distribution of resets and clocks and provides a number of control features. The System Integration Module is responsible for the following functions:

- Reset sequencing
- Clock control & distribution
- Stop/Wait control
- System status registers
- Registers for software access to the JTAG ID of the chip
- Test registers
- Power control
- I/O pad multiplexing

These are discussed in more detail in the sections that follow.

6.2 Features

The SIM has the following features:

- Reset sequencing
 - Core and Peripheral Clock control & distribution
 - Stop/Wait mode control
 - System status
 - Power control
 - Control I/O multiplexing
- System bus clocks with pipeline hold-off support
- System clocks for non-pipelined interfaces
- Peripheral clocks for Quad Timer and PWM with high-speed (3X) option
- Power-saving clock gating for peripherals
- Three power modes (Run, Wait, Stop) to control power utilization
 - Stop mode shuts down the 56800E core, system clock, and peripheral clock
 - Wait mode shuts down the 56800E core and unnecessary system clock operation
 - Run mode supports full part operation
- Controls, with write protection, the enable/disable of 56800E core WAIT and STOP instructions

- Controls, with write protection, the enable/disable of Large Regulator Standby mode
- Controls to route functional signals to selected peripherals and I/O pads
- Controls deassertion sequence of internal resets
- Software-initiated reset
- Four 16-bit registers reset only by a Power-On Reset usable for general-purpose software control
- Timer channel Stop mode clocking controls
- SCI Stop mode clocking control to support LIN Sleep mode stop recovery
- Short addressing location control
- Registers for containing the JTAG ID of the chip
- Controls output to CLKO pin

6.3 Register Descriptions

Table 6-1 SIM Registers (SIM_BASE = \$00 F140)

Address Offset	Address Acronym	Register Name	Section Location
Base + \$0	SIM_CTRL	Control Register	6.3.1
Base + \$1	SIM_RSTAT	Reset Status Register	6.3.2
Base + \$2	SIM_SWC0	Software Control Register 0	6.3.3
Base + \$3	SIM_SWC1	Software Control Register 1	6.3.3
Base + \$4	SIM_SWC2	Software Control Register 2	6.3.3
Base + \$5	SIM_SWC3	Software Control Register 3	6.3.3
Base + \$6	SIM_MSHID	Most Significant Half of JTAG ID	6.3.4
Base + \$7	SIM_LSHID	Least Significant Half of JTAG ID	6.3.5
Base + \$8	SIM_PWR	Power Control Register	6.3.6
		Reserved	
Base + \$A	SIM_CLKOUT	CLKO Select Register	6.3.7
Base + \$B	SIM_GPS	GPIO Peripheral Select Register	6.3.8
Base + \$C	SIM_PCE	Peripheral Clock Enable Register	6.3.9
Base + \$D	SIM_IOSAHI	I/O Short Address Location High Register	6.3.10
Base + \$E	SIM_IOSALO	I/O Short Address Location Low Register	6.3.10

Add. Offset	Address Acronym		15	14	13	12	11	10	9	8	7	6	5	4	3	2	1	0
\$0	SIM_CTRL	R W	TC3_SD	TC2_SD	TC1_SD	TC0_SD	SCL_SD	0	TC3_INP	0	0	0	ONCE_EBL	SW_RST	STOP_DISABLE		WAIT_DISABLE	
\$1	SIM_RSTAT	R W	0	0	0	0	0	0	0	0	0	0	SWR	COPR	EXTR	POR	0	0
\$2	SIM_SWC0	R W	Software Control Data 0															
\$3	SIM_SWC1	R W	Software Control Data 1															
\$4	SIM_SWC2	R W	Software Control Data 2															
\$5	SIM_SWC3	R W	Software Control Data 3															
\$6	SIM_MSHID	R W	0	0	0	0	0	0	0	1	1	1	1	1	0	0	1	0
\$7	SIM_LSHID	R W	0	1	0	0	0	0	0	0	0	0	0	1	1	1	0	1
\$8	SIM_PWR	R W	0	0	0	0	0	0	0	0	0	0	0	0	0	0	LRSTDBY	
	Reserved																	
\$A	SIM_CLKOUT	R W	0	0	0	0	0	0	PWM3	PWM2	PWM1	PWM0	CLK_DIS	CLKOSEL				
\$B	SIM_GPS	R W	TCR	PCR	0	0	CFG_B7	CFG_B6	CFG_B5	CFG_B4	CFG_B3	CFG_B2	CFG_B1	CFG_B0	CFG_A5		CFG_A4	
\$C	SIM_PCE	R W	I2C	0	ADC	0	0	0	0	0	0	TMR	0	SCI	0	SPI	0	PWM
\$D	SIM_IOSAHI	R W	0	0	0	0	0	0	0	0	0	0	0	0	0	0	ISAL[23:22]	
\$E	SIM_IOSALO	R W	ISAL[21:6]															

0	= Read as 0	1	= Read as 1
	= Reserved		= Reserved

Figure 6-1 SIM Register Map Summary

6.3.1 SIM Control Register (SIM_CTRL)

Base + \$0	15	14	13	12	11	10	9	8	7	6	5	4	3	2	1	0
Read	TC3_SD	TC2_SD	TC1_SD	TC0_SD	SCL_SD	0	TC3_INP	0	0	0	ONCE_EBL	SW_RST	STOP_DISABLE		WAIT_DISABLE	
Write																
RESET	0	0	0	0	0	0	0	0	0	0	0	0	0	0	0	0

Figure 6-2 SIM Control Register (SIM_CTRL)

6.3.1.1 Timer Channel 3 Stop Disable (TC3_SD)—Bit 15

This bit enables the operation of the Timer Channel 3 peripheral clock in Stop mode.

- 0 = Timer Channel 3 disabled in Stop mode

- 1 = Timer Channel 3 enabled in Stop mode

6.3.1.2 Timer Channel 2 Stop Disable (TC2_SD)—Bit 14

This bit enables the operation of the Timer Channel 2 peripheral clock in Stop mode.

- 0 = Timer Channel 2 disabled in Stop mode
- 1 = Timer Channel 2 enabled in Stop mode

6.3.1.3 Timer Channel 1 Stop Disable (TC1_SD)—Bit 13

This bit enables the operation of the Timer Channel 1 peripheral clock in Stop mode.

- 0 = Timer Channel 1 disabled in Stop mode
- 1 = Timer Channel 1 enabled in Stop mode

6.3.1.4 Timer Channel 0 Stop Disable (TC0_SD)—Bit 12

This bit enables the operation of the Timer Channel 0 peripheral clock in Stop mode.

- 0 = Timer Channel 0 disabled in Stop mode
- 1 = Timer Channel 0 enabled in Stop mode

6.3.1.5 SCI Stop Disable (SCI_SD)—Bit 11

This bit enables the operation of the SCI peripheral clock in Stop mode. This is recommended for use in LIN mode so that the SCI can generate interrupts and recover from Stop mode while the LIN interface is in Sleep mode and using Stop mode to reduce power consumption.

- 0 = SCI disabled in Stop mode
- 1 = SCI enabled in Stop mode

6.3.1.6 Reserved—Bit 10

This bit field is reserved or not implemented. It is read as 0 and cannot be modified by writing.

6.3.1.7 Timer Channel 3 Input (TC3_INP)—Bit 9

This bit selects the input of Timer Channel 3 to be from the PWM sync signal or GPIO pin.

- 1 = Timer Channel 3 Input from PWM sync signal
- 0 = Timer Channel 3 Input controlled by SIM_GPS register CFG_B3 and CFG_A5 fields

6.3.1.8 Reserved—Bits 8–6

This bit field is reserved or not implemented. It is read as 0 and cannot be modified by writing.

6.3.1.9 OnCE Enable (ONCEEBL)—Bit 5

- 0 = OnCE clock to 56800E core enabled when core TAP is enabled
- 1 = OnCE clock to 56800E core is always enabled

6.3.1.10 Software Reset (SWRST)—Bit 4

Writing 1 to this field will cause the part to reset.

6.3.1.11 Stop Disable (STOP_DISABLE[1:0])—Bits 3–2

- 00 = Stop mode will be entered when the 56800E core executes a STOP instruction
- 01 = The 56800E STOP instruction will not cause entry into Stop mode
- 10 = Stop mode will be entered when the 56800E core executes a STOP instruction and the STOP_DISABLE field is write-protected until the next reset
- 11 = The 56800E STOP instruction will not cause entry into Stop mode and the STOP_DISABLE field is write-protected until the next reset

6.3.1.12 Wait Disable (WAIT_DISABLE[1:0])—Bits 1–0

- 00 = Wait mode will be entered when the 56800E core executes a WAIT instruction
- 01 = The 56800E WAIT instruction will not cause entry into Wait mode
- 10 = Wait mode will be entered when the 56800E core executes a WAIT instruction and the WAIT_DISABLE field is write-protected until the next reset
- 11 = The 56800E WAIT instruction will not cause entry into Wait mode and the WAIT_DISABLE field is write-protected until the next reset

6.3.2 SIM Reset Status Register (SIM_RSTAT)

This register is updated upon any system reset and indicates the cause of the most recent reset. It also controls whether the COP reset vector or regular reset vector in the vector table is used. This register is asynchronously reset during Power-On Reset (see power supervisor module) and subsequently is synchronously updated based on the level of the external reset, software reset, or cop reset inputs. Only one source will ever be indicated. In the event that multiple reset sources assert simultaneously, the highest-precedence source will be indicated. The precedence from highest to lowest is POR, EXTR, COPR, and SWR. While POR is always set during a Power-On Reset, EXTR will become set if the external reset pin is asserted or remains asserted after the Power-On Reset (POR) has deasserted.

Base + \$1	15	14	13	12	11	10	9	8	7	6	5	4	3	2	1	0
Read	0	0	0	0	0	0	0	0	0	0	SWR	COPR	EXTR	POR	0	0
Write																
RESET	0	0	0	0	0	0	0	0	0	0					0	0

Figure 6-3 SIM Reset Status Register (SIM_RSTAT)

6.3.2.1 Reserved—Bits 15–6

This bit field is reserved or not implemented. It is read as zero and cannot be modified by writing.

6.3.2.2 Software Reset (SWR)—Bit 5

When set, this bit indicates that the previous system reset occurred as a result of a software reset (written 1 to SW RST bit in the SIM_CTRL register). It will not be set if a COP, external, or POR reset also occurred.

6.3.2.3 COP Reset (COPR)—Bit 4

When set, this bit indicates that the previous system reset was caused by the Computer Operating Properly

(COP) timer. It will not be set if an external or POR reset also occurred. If COPR is set as code starts executing, the COP reset vector in the vector table will be used. Otherwise, the normal reset vector is used.

6.3.2.4 External Reset (EXTR)—Bit 3

When set, this bit indicates that the previous system reset was caused by an external reset. It will only be set if the external reset pin was asserted or remained asserted after the Power-On Reset deasserted.

6.3.2.5 Power-On Reset (POR)—Bit 2

This bit is set during a Power-On Reset.

6.3.2.6 Reserved—Bits 1–0

This bit field is reserved or not implemented. It is read as 0 and cannot be modified by writing.

6.3.3 SIM Software Control Registers (SIM_SWC0, SIM_SWC1, SIM_SWC2, and SIM_SWC3)

Only SIM_SWC0 is shown in this section. SIM_SWC1, SIM_SWC2, and SIM_SWC3 are identical in functionality.

Base + \$2	15	14	13	12	11	10	9	8	7	6	5	4	3	2	1	0
Read	Software Control Data 0															
Write	Software Control Data 0															
RESET	0	0	0	0	0	0	0	0	0	0	0	0	0	0	0	0

Figure 6-4 SIM Software Control Register 0 (SIM_SWC0)

6.3.3.1 Software Control Data 0 (FIELD)—Bits 15–0

This register is reset only by the Power-On Reset (POR). It has no part-specific functionality and is intended for use by a software developer to contain data that will be unaffected by the other reset sources ($\overline{\text{RESET}}$ pin, software reset, and COP reset).

6.3.4 Most Significant Half of JTAG ID (SIM_MSHID)

This read-only register displays the most significant half of the JTAG ID for the chip. This register reads \$01F2.

Base + \$6	15	14	13	12	11	10	9	8	7	6	5	4	3	2	1	0
Read	0	0	0	0	0	0	0	1	1	1	1	1	0	0	1	0
Write																
RESET	0	0	0	0	0	0	0	1	1	1	1	1	0	0	1	0

Figure 6-5 Most Significant Half of JTAG ID (SIM_MSHID)

6.3.5 Least Significant Half of JTAG ID (SIM_LSHID)

This read-only register displays the least significant half of the JTAG ID for the chip. This register reads \$401D.

Base + \$7	15	14	13	12	11	10	9	8	7	6	5	4	3	2	1	0
Read	0	1	0	0	0	0	0	0	0	0	0	1	1	1	0	1
Write																
RESET	0	1	0	0	0	0	0	0	0	0	0	1	1	1	0	1

Figure 6-6 Least Significant Half of JTAG ID (SIM_LSHID)

6.3.6 SIM Power Control Register (SIM_PWR)

This register controls the Standby mode of the large regulator. The large regulator derives the core digital logic power supply from the IO power supply. In some circumstances, the large regulator may be put in a reduced-power Standby mode without interfering with part operation. Refer to the overview of power-down modes and the overview of clock generation for more information on the use of large regulator standby.

Base + \$8	15	14	13	12	11	10	9	8	7	6	5	4	3	2	1	0
Read	0	0	0	0	0	0	0	0	0	0	0	0	0	0	LRSTDBY	
Write																
RESET	0	0	0	0	0	0	0	0	0	0	0	0	0	0	0	0

Figure 6-7 SIM Power Control Register (SIM_PWR)

6.3.6.1 Reserved—Bits 15–2

This bit field is reserved or not implemented. It is read as 0 and cannot be modified by writing.

6.3.6.2 Large Regulator Standby Mode[1:0] (LRSTDBY)—Bits 1–0

This bit controls the pull-up resistors on the IRQA pin.

- 00 = Large regulator is in Normal mode
- 01 = Large regulator is in Standby (reduced-power) mode
- 10 = Large regulator is in Normal mode and the LRSTDBY field is write-protected until the next reset
- 11 = Large regulator is in Standby mode and the LRSTDBY field is write-protected until the next reset

Note: Standby mode can be used when the device operates below 200 kHz if the PLL is shut down.

6.3.7 CLKO Select Register (SIM_CLKOUT)

The CLKO select register can be used to multiplex out selected clocks generated inside the clock generation and SIM modules. All functionality is for test purposes only and is subject to unspecified latencies. Glitches may be produced when the clock is enabled or switched.

The lower four bits of the GPIO A register can function as GPIO, PWM, or as additional clock output signals. GPIO has priority and is enabled/disabled via the GPIOA_PEREN. If GPIOA[3:0] are programmed to operate as peripheral outputs, then the choice between PWM and additional clock outputs is done here in the CLKOUT. The default state is for the peripheral function of GPIOA[3:0] to be programmed as PWM. This can be changed by altering $\overline{\text{PWM}}3$ through $\overline{\text{PWM}}0$.

Base + \$A	15	14	13	12	11	10	9	8	7	6	5	4	3	2	1	0
Read	0	0	0	0	0	0	$\overline{\text{PWM}}3$	$\overline{\text{PWM}}2$	$\overline{\text{PWM}}1$	$\overline{\text{PWM}}0$	CLK DIS	CLKOSEL				
Write																
RESET	0	0	0	0	0	0	0	0	0	0	1	0	0	0	0	0

Figure 6-8 CLKO Select Register (SIM_CLKOUT)

6.3.7.1 Reserved—Bits 15–10

This bit field is reserved or not implemented. It is read as 0 and cannot be modified by writing.

6.3.7.2 $\overline{\text{PWM}}3$ —Bit 9

- 0 = Peripheral output function of GPIOA[3] is defined to be $\overline{\text{PWM}}3$
- 1 = Peripheral output function of GPIOA[3] is defined to be the Relaxation Oscillator Clock

6.3.7.3 $\overline{\text{PWM}}2$ —Bit 8

- 0 = Peripheral output function of GPIOA[2] is defined to be $\overline{\text{PWM}}2$
- 1 = Peripheral output function of GPIOA[2] is defined to be the system clock

6.3.7.4 $\overline{\text{PWM}}1$ —Bit 7

- 0 = Peripheral output function of GPIOA[1] is defined to be $\overline{\text{PWM}}1$
- 1 = Peripheral output function of GPIOA[1] is defined to be two times the rate of the system clock

6.3.7.5 $\overline{\text{PWM}}0$ —Bit 6

- 0 = Peripheral output function of GPIOA[0] is defined to be $\overline{\text{PWM}}0$
- 1 = Peripheral output function of GPIOA[0] is defined to be three times the rate of the system clock

6.3.7.6 Clockout Disable (CLKDIS)—Bit 5

- 0 = CLKOUT output is enabled and will output the signal indicated by CLKOSEL
- 1 = CLKOUT is 0

6.3.7.7 Clockout Select (CLKOSEL)—Bits 4–0

Selects clock to be muxed out on the CLKO pin.

- 00000 = Reserved for factory test—Continuous system clock
- 01001 = Reserved for factory test—OCCS MSTR OSC clock
- 01011 = Reserved for factory test—ADC clock
- 01100 = Reserved for factory test—JTAG TCLK

- 01101 = Reserved for factory test—Continuous peripheral clock
- 01110 = Reserved for factory test—Continuous inverted peripheral clock
- 01111 = Reserved for factory test—Continuous high-speed peripheral clock

6.3.8 SIM GPIO Peripheral Select Register (SIM_GPS)

All of the peripheral pins on the 56F8014 share their Input/Output (I/O) with GPIO ports. To select peripheral or GPIO control, program the corresponding bit in the GPIOx_PEREN register in the GPIO module. (See *MC56F8000RM*, the 56F801x Peripheral Reference Manual, for details.) In some cases, there are two possible peripherals as well as the GPIO functionality available for control of the I/O. In these cases, the SIM_GPS register is used to determine which peripheral has control when the corresponding I/O pin is configured in peripheral mode.

As shown in [Figure 6-9](#), the GPIO Peripheral Enable Register (PEREN) has the final control over which pin controls the I/O. SIM_GPS simply decides which peripheral will be routed to the I/O when PEREN = 1.

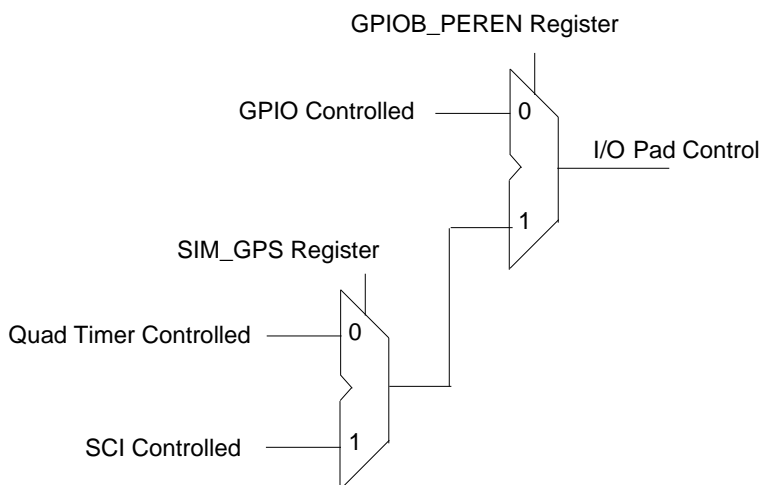

Figure 6-9 Overall Control of Pads Using SIM_GPS Control

Base + \$B	15	14	13	12	11	10	9	8	7	6	5	4	3	2	1	0
Read	TCR	PCR	0	0	CFG_B7	CFG_B6	CFG_B5	CFG_B4	CFG_B3	CFG_B2	CFG_B1	CFG_B0	CFG_A5		CFG_A4	
Write																
RESET	0	0	0	0	0	0	0	0	0	0	0	0	0	0	0	0

Figure 6-10 GPIO Peripheral Select Register (SIM_GPS)

6.3.8.1 Quad Timer Clock Rate (TCR)—Bit 15

This bit selects the clock speed for the Quad Timer module.

- 0 = Quad Timer module clock rate equals system clock rate, to a maximum 32 MHz (default)
- 1 = Quad Timer module clock rate equals three times system clock rate, to a maximum 96 MHz

Note: This bit should only be changed while the Quad Timer module's clock is disabled. See [Section 6.3.9](#).

Note: High-speed clocking is only available when the PLL is being used.

Note: If the PWM sync signal is used as input to Timer 3 (See SIM_CTRL: TC3_INP, [Section 6.3.1.7](#)), then the clocks of the Quad Timer and PWM must be related, as shown in [Table 6-2](#).

6.3.8.2 PWM Clock Rate (PCR)—Bit 14

This bit selects the clock speed for the PWM module.

- 0 = PWM module clock rate equals system clock rate, to a maximum 32 MHz (default)
- 1 = PWM module clock rate equals three times system clock rate, to a maximum 96 MHz

Note: This bit should only be changed while the PWM module's clock is disabled. See [Section 6.3.9](#).

Note: High-speed clocking is only available when the PLL is being used.

Note: If the PWM sync signal is used as input to Timer 3 (See SIM_CTRL: TC3_INP, [Section 6.3.1.7](#)), then the clocks of the Quad Timer and PWM must be related, as shown in [Table 6-2](#).

Table 6-2 Allowable Quad Timer and PWM Clock Rates when Using PWM Reload Pulse

		Quad Timer	
		1X	3X
PWM	1X	OK	OK
	3X	NO	OK

6.3.8.3 Reserved—Bits 13–12

This bit field is reserved or not implemented. It is read as 0 and cannot be modified by writing.

6.3.8.4 Configure GPIOB7 (CFG_B7)—Bit 11

This bit selects the alternate function for GPIOB7.

- 0 = TXD — SCI Transmit Data (default)
- 1 = SCL — I²C Serial Clock

6.3.8.5 Configure GPIOB6 (CFG_B6)—Bit 10

This bit selects the alternate function for GPIOB6.

- 0 = RXD — SCI Receive Data (default)
- 1 = SDA — I²C Serial Data

Note: The PRECS bit in the OCCS Oscillator Control register can enable this pin as the

source clock to the chip. In this mode, make sure that no on-chip peripheral (including the GPIO) is driving this pin.

6.3.8.6 Configure GPIOB5 (CFG_B5)—Bit 9

This bit selects the alternate function for GPIOB5.

- 0 = T1 — Timer channel 1 input/output (default)
- 1 = FAULT3 — PWM FAULT3 input

6.3.8.7 Configure GPIOB4 (CFG_B4)—Bit 8

This bit selects the alternate function for GPIOB4.

- 0 = T0 — Timer channel 0 input/output (default)
- 1 = CLKO — Clock output

6.3.8.8 Configure GPIOB3 (CFG_B3)—Bit 7

This bit selects the alternate function for GPIOB3.

- 0 = MOSI — SPI master out/slave in (default)
- 1 = T3 — Timer channel 3 input/output

6.3.8.9 Configure GPIOB2 (CFG_B2)—Bit 6

This bit selects the alternate function for GPIOB2.

- 0 = MISO — SPI master in/slave out (default)
- 1 = T2 — Timer channel 2 input/output

6.3.8.10 Configure GPIOB1 (CFG_B1)—Bit 5

This bit selects the alternate function for GPIOB1.

- 0 = SS — SPI Slave Select (default)
- 1 = SDA — I²C Serial Data

6.3.8.11 Configure GPIOB0 (CFG_B0)—Bit 4

This bit selects the alternate function for GPIOB0.

- 0 = SCLK — SPI Serial Clock (default)
- 1 = SCL — I2C Serial Clock

6.3.8.12 Configure GPIOA5[1:0] (CFG_A5)—Bits 3–2

These bits select the alternate function for GPIOA5.

- 00 = PWM5 — PWM5 output (default)
- 01 = PWM5 — PWM5 output
- 10 = FAULT2 — PWM FAULT2 input

- 11 = T3 — Timer Channel 3 input/output

6.3.8.13 Configure GPIOA4[1:0] (CFG_A4)—Bits 1–0

These bits select the alternate function for GPIOA4.

- 00 = PWM4 — PWM4 output
- 01 = PWM4 — PWM4 output
- 10 = FAULT1 — PWM FAULT1 input
- 11 = T2 — Timer Channel 2 input/output

Note: When programming the CFG_* signals be careful so as not to connect two different I/O pins to the same peripheral input. For example, do not set CFG_B7 to select SCL and also set CFG_B0 to select SCL. If this occurs for an output signal, then the signal will be routed to two I/O pins. For input signals, the values on the two I/O pins will be ORed together before reaching the peripheral.

6.3.9 Peripheral Clock Enable Register (SIM_PCE)

The Peripheral Clock Enable register is used to enable or disable clocks to the peripherals as a power savings feature. The clocks can be individually controlled for each peripheral on the chip. The corresponding peripheral should itself be disabled while its clock is shut off.

Base + \$C	15	14	13	12	11	10	9	8	7	6	5	4	3	2	1	0
Read	I2C	0	ADC	0	0	0	0	0	0	TMR	0	SCI	0	SPI	0	PWM
Write																
RESET	0	0	0	0	0	0	0	0	0	0	0	0	0	0	0	0

Figure 6-11 Peripheral Clock Enable Register (SIM_PCE)

6.3.9.1 I²C Clock Enable (I2C)—Bit 15

- 0 = The clock is not provided to the I²C module (the I²C module is disabled)
- 1 = Clocks to the I²C module are enabled

6.3.9.2 Reserved—Bit 14

This bit field is reserved or not implemented. It is read as 0 and cannot be modified by writing.

6.3.9.3 Analog-to-Digital Converter IPBus Clock Enable (ADC)—Bit 13

- 0 = The clock is not provided to the ADC module (the ADC module is disabled)
- 1 = Clocks to the ADC module are enabled

6.3.9.4 Reserved—Bits 12–7

This bit field is reserved or not implemented. It is read as 0 and cannot be modified by writing.

6.3.9.5 Timer Clock Enable (TMR)—Bit 6

- 0 = The clock is not provided to the Quad Timer module (the Quad Timer module is disabled)

- 1 = Clocks to the Quad Timer module are enabled

6.3.9.6 Reserved—Bit 5

This bit field is reserved or not implemented. It is read as 0 and cannot be modified by writing.

6.3.9.7 SCI IPBus Clock Enable (SCI)—Bit 4

- 0 = The clock is not provided to the SCI module (the SCI module is disabled)
- 1 = Clocks to the SCI module are enabled

6.3.9.8 Reserved—Bit 3

This bit field is reserved or not implemented. It is read as 0 and cannot be modified by writing.

6.3.9.9 SPI Clock Enable (SPI)—Bit 2

- 0 = The clock is not provided to the SPI module (the SPI module is disabled)
- 1 = Clocks to the SPI module are enabled

6.3.9.10 Reserved—Bit 1

This bit field is reserved or not implemented. It is read as 0 and cannot be modified by writing.

6.3.9.11 PWM Clock Enable (PWM)—Bit 0

- 0 = The clock is not provided to the PWM module (the PWM module is disabled)
- 1 = Clocks to the PWM module are enabled

6.3.10 I/O Short Address Location Register (SIM_IOSAHI and SIM_IOSALO)

The I/O Short Address Location registers are used to specify the memory referenced via the I/O short address mode. The I/O short address mode allows the instruction to specify the lower six bits of address; the upper address bits are not directly controllable. This register set allows limited control of the full address, as shown in [Figure 6-12](#).

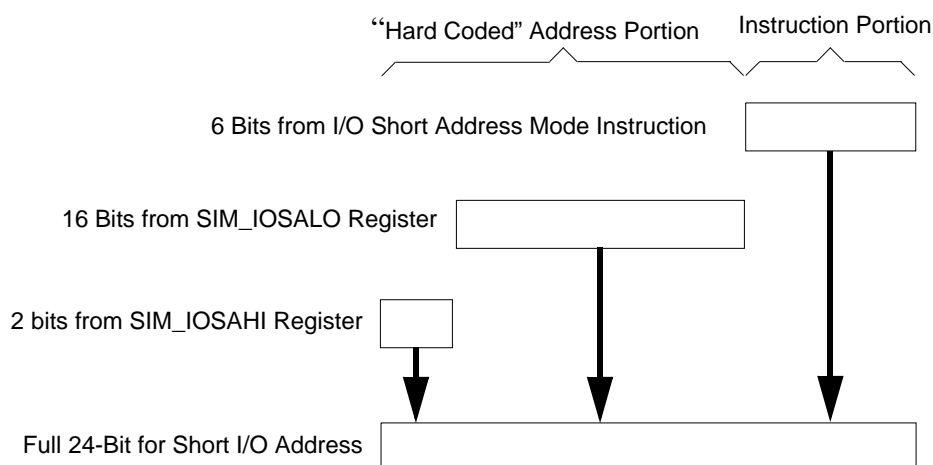

Figure 6-12 I/O Short Address Determination

With this register set, an interrupt driver can set the SIM_IOSALO register pair to point to its peripheral registers and then use the I/O Short addressing mode to reference them. The ISR should restore this register to its previous contents prior to returning from interrupt.

Note: The default value of this register set points to the EOnCE registers.

Note: The pipeline delay between setting this register set and using short I/O addressing with the new value is five instruction cycles.

Base + \$D	15	14	13	12	11	10	9	8	7	6	5	4	3	2	1	0
Read	0	0	0	0	0	0	0	0	0	0	0	0	0	0	ISAL[23:22]	
Write																
RESET	0	0	0	0	0	0	0	0	0	0	0	0	0	0	1	1

Figure 6-13 I/O Short Address Location High Register (SIM_IOSAHI)

6.3.10.1 Reserved—Bits 15—2

This bit field is reserved or not implemented. It is read as 0 and cannot be modified by writing.

6.3.10.2 Input/Output Short Address Location (ISAL[23:22])—Bit 1—0

This field represents the upper two address bits of the “hard coded” I/O short address.

Base + \$E	15	14	13	12	11	10	9	8	7	6	5	4	3	2	1	0
Read	ISAL[21:6]															
Write																
RESET	1	1	1	1	1	1	1	1	1	1	1	1	1	1	1	1

Figure 6-14 I/O Short Address Location Low Register (SIM_IOSALO)

6.3.10.3 Input/Output Short Address Location (ISAL[21:6])—Bit 15–0

This field represents the lower 16 address bits of the “hard coded” I/O short address.

6.4 Clock Generation Overview

The SIM uses master clocks, 2X system clock at a maximum of 64 MHz, from the OCCS module to produce the peripheral and system (core and memory) clocks at a maximum of 32 MHz. It divides the master clock by two and gates it with appropriate power mode and clock gating controls. The high speed peripheral clock input from OCCS operates at three times the system clock for PWM and Quad Timer module at a maximum of 96 MHz.

The OCCS configuration controls the operating frequency of the SIM’s master clocks. In the OCCS, either an external clock or the relaxation oscillator can be selected as the master clock source (MSTR_OSC). When selected, the relaxation oscillator can be operated at full speed (8 MHz), standby speed (200 kHz), or powered down. An 8 MHz clock can be multiplied to 192 MHz using the PLL and postscaled to provide a variety of high speed clock rates. Either the postscaled PLL output or the input clock of the PLL signal can be selected to produce the master clocks to the SIM. When the PLL is not selected, the high speed peripheral clock is disabled and the 2x system clock is the input clock from either the internal relaxation oscillator or from an external clock source.

In combination with the OCCS module, the SIM provides power modes (see [Section 6.5](#)), clock enables (SIM_PCE register, CLK_DIS, ONCE_EBL), and clock rate controls (TCR, PCR) to provide flexible control of clocking and power utilization. The SIM’s clock enable controls can be used to disable individual clocks when not needed. The clock rate controls enable the high speed clocking option for the Timer channels and PWM but require the PLL to be on and selected. Refer to the **56F801X Peripheral Reference Manual** for further details.

6.5 Power-Down Modes

The 56F8014 operates in one of five Power-Down modes, as shown in [Table 6-3](#).

Table 6-3 Clock Operation in Power-Down Modes

Mode	Core Clocks	Peripheral Clocks	Description
Run	Core and memory clocks disabled	Peripheral clocks enabled	Device is fully functional

Table 6-3 Clock Operation in Power-Down Modes (Continued)

Mode	Core Clocks	Peripheral Clocks	Description
Wait	Core and memory clocks disabled	Peripheral clocks enabled	Core executes WAIT instruction to enter this mode. Typically used for power-conscious applications. Possible recoveries from Wait mode to Run mode are: <ol style="list-style-type: none"> 1. Any interrupt 2. Executing a Debug mode entry command during the 56800E core JTAG interface 2. Any reset (POR, external, software, COP)
Stop	Master clock generation in the OCCS remains operational, but the SIM disables the generation of system and peripheral clocks.		Core executes STOP instruction to enter this mode. Possible recoveries from Stop mode to Run mode are: <ol style="list-style-type: none"> 1. Interrupt from Timer channels that have been configured to operate in Stop mode (TCx_SD) 2. Interrupt for SCI configured to operate in Stop mode (SCI_SD) 3. Low-voltage interrupt 4. Executing a Debug mode entry command using the 56800E core JTAG interface 5. Any reset (POR, external, software, COP)
Standby	The OCCS generates the 2x System Clock at a reduced frequency (200 kHz). The PLL and high speed peripheral clocks are disabled and the high-speed peripheral option is not available. System and peripheral clocks operate at 100 kHz.		The user configures the OCCS and SIM to select the relaxation oscillator clock source (PRECS), shut down the PLL (PLLPD), put the relaxation oscillator in Standby mode (ROSB), and put the large regulator in Standby (LRSTDBY). The part is fully operational, but operating at a minimum frequency and power configuration. Recovery requires reversing the sequence used to enter this mode (allowing for PLL lock time).
Power-Down	Master clock generation in the OCCS is completely shut down. All system and peripheral clocks are disabled.		The user configures the OCCS and SIM to enter Standby mode as shown in the previous description, followed by powering down the oscillator (ROPD). The only possible recoveries from this mode are: <ol style="list-style-type: none"> 1. External reset 2. Power-on reset

The power modes provide additional means to disable clock domains, configure the voltage regulator, and configure clock generation to manage power utilization, as shown in [Table 6-3](#). Run, Wait, and Stop modes provide means of enabling/disabling the peripheral and/or core clocking as a group. Stop disable controls are provided for selected peripherals in the control register so that these peripheral clocks can optionally continue to operate in Stop mode and generate interrupts which will return the part from Stop to Run mode. Standby mode provides normal operation but at very low speed and power utilization. It is possible to invoke Stop or Wait mode while in Standby mode for even greater levels of power reduction. A 200 kHz clock external clock can optionally be used in Standby mode to produce the required Standby 100 kHz system bus rate. Power-down mode, which selects the ROSC clock source but shuts it off, fully disables the part and minimizes its power utilization but is only recoverable via reset.

When the PLL is not selected and the system bus is operating at around 100 kHz, the large regulator can

be put into its Standby mode (LRSTDBY) to reduce the power utilization of that regulator.

All peripherals, except the COP/watchdog timer, run at the system clock (peripheral bus) frequency¹, which is the same as the main processor frequency in this architecture. The COP timer runs at $MSTR_OSC / 1024$. The maximum frequency of operation is $SYS_CLK = 32\text{MHz}$. The only exception is the Quad Timer and PWM, which can be configured to operate at three times the system bus rate using TCR and PCR controls, provided the PLL is active and selected.

6.6 Resets

The SIM supports four sources of reset, as shown in [Figure 6-15](#). The two asynchronous sources are the external reset pin and the Power-On Reset (POR). The two synchronous sources are the software reset, which is generated within the SIM itself by writing the SIM_CTRL register in [Section 6.3.1](#), and the COP reset. The SIM uses these to generate resets for the internal logic. These are outlined in [Table 6-4](#). The first column lists the four primary resets which are calculated. The JTAG circuitry is reset by the Power-On Reset. Columns two through five indicate which reset sources trigger these reset signals. The last column provides additional detail.

Table 6-4 Primary System Resets

Reset Signal	Reset Sources				Comments
	POR	External	Software	COP	
EXTENDED_POR	X				Stretched version of $\overline{\text{POR}}$. Relevant 64 Relaxation Oscillator Clock cycles after $\overline{\text{POR}}$ deasserts.
CLKGEN_RST	X	X	X	X	Released 32 Relaxation Oscillator Clock cycles after all reset sources have released.
PERIP_RST	X	X	X	X	Releases 32 Relaxation Oscillator Clock cycles after the CLKGEN_RST is released.
CORE_RST	X	X	X	X	Releases 32 SYS_CLK periods after PERIP_RST is released.

[Figure 6-15](#) provides a graphic illustration of the details in [Table 6-4](#). Note that the POR_Delay blocks use the Relaxation Oscillator Clock as their time base since other system clocks are inactive during this phase of reset.

1. The Quad Timer and PWM modules can be operated at three times the IPBus clock frequency.

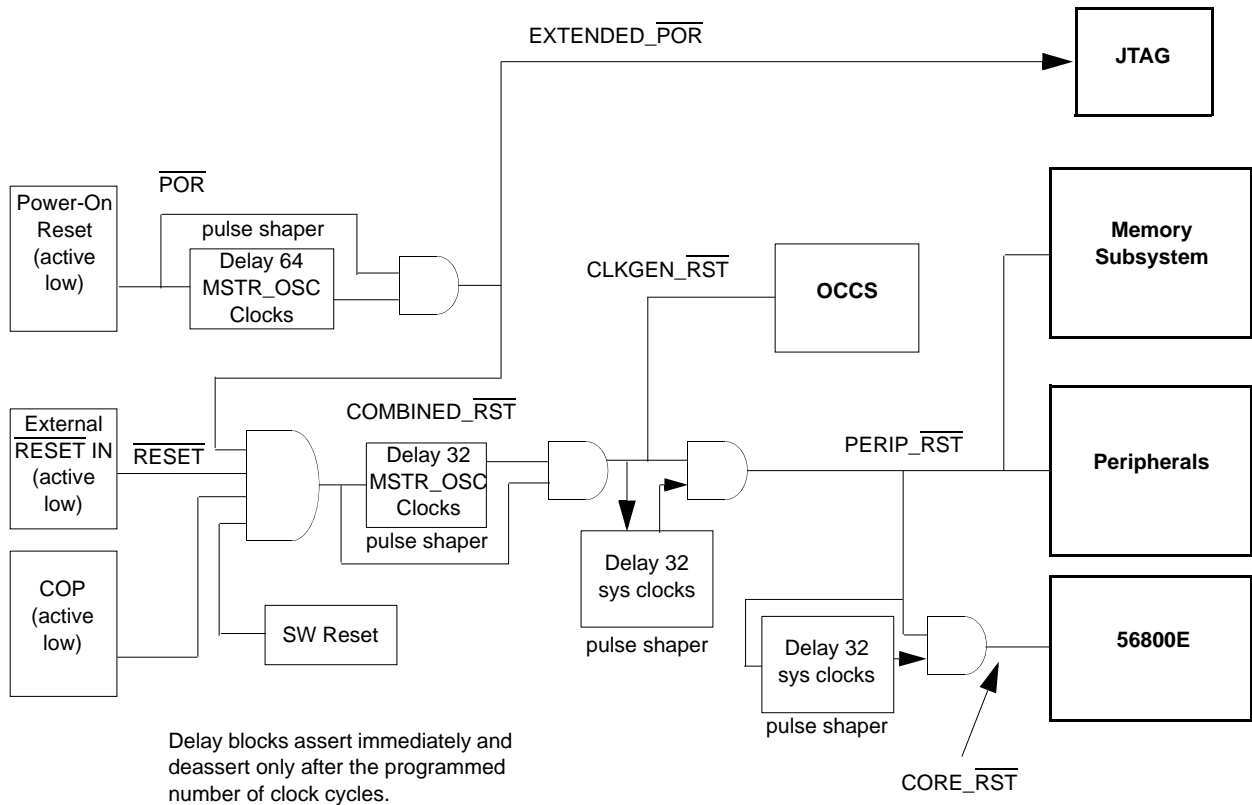

Figure 6-15 Sources of RESET Functional Diagram (Test modes not included)

POR resets are extended 64 MSTR_osc clocks to stabilize the power supply. All resets are subsequently extended for an additional 32 MSTR_osc clocks and 64 system clocks as the various internal reset controls are released. Given the normal relaxation oscillator rate of 8MHz, the duration of a POR reset from when power comes on to when code is running is 28µs. An external reset generation chip may also be used. Resets may be asserted asynchronously, but they are always released internally on a rising edge of the system clock.

6.7 Clocks

The memory, peripheral and core clocks all operate at the same frequency (32MHz max) with the exception of the TMR and PWM peripheral clocks, which have the option (using TCR and PCR) to operate three times faster. The SIM is responsible for stalling individual clocks as a response to various hold-off requests, low power modes, and other configuration parameters. The SIM has access to the following signals from the OCCS module:

MSTR_OSC	This comes from the input clock source mux of the OCCS. It is the output of the relaxation oscillator or the external clock source, depending on PRECS. It is not guaranteed to be at 50% duty cycle (+ or - 10% can probably be assumed for design purposes). This clock runs continuously, even during reset and is used for reset generation.
HS_PERF	The PLL multiplies the MSTR_OSC by 24, to a maximum of 192MHz. The ZSRC field in OCCS selects the active source to be the PLL. This is divided by 2 and postscaled to produce this maximum 96MHz clock. It is used without further division to produce the high-speed (3x system bus rate) variants of the Quad Timer and PWM peripheral clocks. This clock is disabled when ZSRC is selecting MSTR_OSC.
SYS_CLK_x2	The PLL can multiply the MSTR_OSC by 24, to a maximum of 192MHz. When the PLL is selected by the OCCS ZSRC field, the PLL is divided by three and postscaled to produce this maximum 64MHz clock. When MSTR_OSC is selected by the OCCS ZSRC field, MSTR_OSC feeds SYS_CLK_x2 directly. The SIM takes this clock and divides it by two to generate all the normal (1x system bus rate) peripheral and system clocks.

While the SIM generates the ADC peripheral clock in the same way it generates all other peripheral clocks, the ADC standby and conversion clocks are generated by a direct interface between the ADC and the OCCS module.

Figure 6-16 illustrates clock relationships to one another and to the various resets as the device comes out of reset. $\overline{\text{RST}}$ is assumed to be the logical AND of all active-low system resets (for example, POR, external reset, COP and Software reset). In the 56F8014 architecture, this signal will be stretched by the SIM for a period of time (up to 96 MSTR_OSC clock cycles, depending upon the status of the POR) to create the clock generation reset signal ($\overline{\text{CLKGEN_RST}}$). The SIM should deassert $\overline{\text{CLKGEN_RST}}$ synchronously with the negative edge of OSC_CLK in order to avoid skew problems. $\overline{\text{CLKGEN_RST}}$ is delayed 32 SYS_CLK cycles to create the peripheral reset signal ($\overline{\text{PERIP_RST}}$). $\overline{\text{PERIP_RST}}$ is then delayed by 32 SYS_CLK cycles to create $\overline{\text{CORE_RST}}$. Both $\overline{\text{PERIP_RST}}$ and $\overline{\text{CORE_RST}}$ should be released on the negative edge of SYS_CLK_D as shown. This phased releasing of system resets is necessary to give some peripherals (for example, the Flash interface unit) set-up time prior to the 56800E core becoming active.



Maximum Delay = 64 MSTR_OSC cycles for POR reset extension and 32 MSTR_OSC cycles for combined reset extension

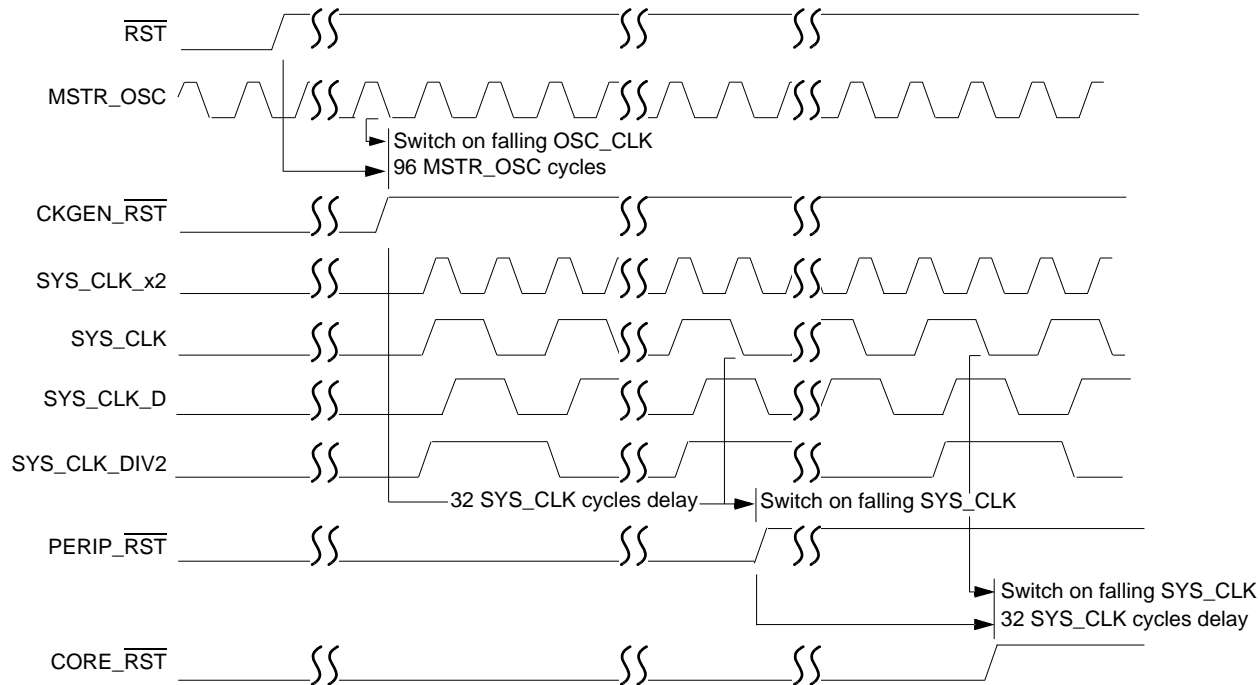

Figure 6-16 Timing Relationships of Reset Signal to Clocks

6.8 Interrupts

The SIM generates no interrupts.

Part 7 Security Features

The 56F8014 offers security features intended to prevent unauthorized users from reading the contents of the flash memory (FM) array. The 56F8014's flash security consists of several hardware interlocks that prevent unauthorized users from gaining access to the flash array.

After flash security is set, an authorized user is still able to access on-chip memory if the user purposely includes a subroutine to read and transfer the contents of internal memory via serial communication peripherals, as this code would defeat the purpose of security.

7.1 Operation with Security Enabled

After the user has programmed the flash with his application code, the 56F8014 can be secured by programming a security word (\$E70A) into program memory location \$00 1FF7. This nonvolatile word will keep the device secured through reset and through power-down of the device. Refer to the flash

memory chapter in *MC56F8000RM*, the 56F8000 Peripheral Reference Manual for details. When flash security mode is enabled, the 56F8014 will disable the core EOnCE debug capabilities. Normal program execution is otherwise unaffected.

7.2 Flash Access Lock and Unlock Mechanisms

There are several methods that effectively lock or unlock the on-chip flash.

7.2.1 Disabling EOnCE Access

On-chip flash can be read by issuing commands across the EOnCE port, which is the debug interface for the 56800E CPU. The TCK, TMS, TDO, and TDI pins comprise a JTAG interface onto which the EOnCE port functionality is mapped. When the device boots, the chip-level JTAG TAP (Test Access Port) is active and provides the chip's boundary scan capability and access to the ID register, but proper implementation of flash security will block any attempt to access the internal flash memory via the EOnCE port when security is enabled.

7.2.2 Flash Lockout Recovery Using JTAG

If the device is secured, one lockout recovery mechanism is the complete erasure of the internal flash contents, including the configuration field, thus disabling security (the protection register is cleared). This does not compromise security, as the entire contents of the user's secured code stored in flash are erased before security is disabled on the device on the next reset or power-up sequence.

To start the lockout recovery sequence via JTAG, the JTAG public instruction (LOCKOUT_RECOVERY) must first be shifted into the chip-level TAP controller's instruction register. Once the LOCKOUT_RECOVERY instruction has been shifted into the instruction register, the clock divider value must be shifted into the corresponding 7-bit data register. After the data register has been updated, the user must transition the TAP controller into the RUN-TEST/IDLE state for the lockout sequence to commence. The controller must remain in this state until the erase sequence has completed. Refer to *MC56F8000RM*, the 56F8000 Peripheral Reference Manual, for more details, or contact Freescale.

Note: Once the lockout recovery sequence has completed, the user must reset both the JTAG-TAP controller and the device to return to normal unsecured operation. Power-on reset will also reset both.

7.2.3 Flash Lockout Recovery Using CodeWarrior

CodeWarrior can unlock a device by selecting the Debug menu, then selecting DSP56800E, followed by Unlock Flash. Another mechanism is also built into CodeWarrior using the device's memory configuration file. The command `Unlock_Flash_on_Connect1` in the `.cfg` file accomplishes the same task as using the Debug menu.

This lockout recovery mechanism also includes the complete erasure of the internal flash contents, including the configuration field, thus disabling security (the protection register is cleared).

7.2.4 Flash Lockout Recovery Without Mass Erase

The user can un-secure a secured device by programming the word \$0000 into program memory location \$00 1FF7. After completing the programming, both the JTAG TAP controller and the device must be reset

in order to return to normal unsecured operation. Power-on reset will also reset both.

The user is responsible for directing the device to invoke the flash programming subroutine to reprogram the word \$0000 into program memory location \$00 1FF7. This is done by, for example, toggling a specific pin, or by downloading a user-defined key through serial interfaces.

Note: Flash contents can only be programmed for 1s to 0s.

7.3 Product Analysis

The recommended method of unsecuring a secured device for product analysis of field failures is via the method suggested in section 7.2.4. The customer would need to supply Technical Support with the details of the protocol to access the subroutines in flash. An alternative method for performing analysis on a secured device would be to mass-erase and reprogram the flash with the original code, but also either modify the security word or else not program the security word.

Part 8 General Purpose Input/Output (GPIO)

8.1 Introduction

This section is intended to supplement the GPIO information found in the **56F801X Peripheral Reference Manual** and contains only chip-specific information. This information supercedes the generic information in the **56F801X Peripheral Reference Manual**.

8.2 Configuration

There are four GPIO ports defined on the 56F8014. The width of each port, the associated peripheral and reset functions are shown in [Table 8-1](#). The specific mapping of GPIO port pins is shown in [Table 8-2](#).

Table 8-1 GPIO Ports Configuration

GPIO Port	Available Pins in 56F8014	Peripheral Function	Reset Function
A	6	PWM, Reset	GPIO, except GPIOA7
B	8	SPI, SCI, Timer	GPIO
C	8	ADC	Analog
D	4	JTAG	JTAG

Table 8-2 GPIO External Signals Map
 Pins in shaded rows are not available in 56F8014

GPIO Function	Peripheral Function	LQFP Package Pin	Notes
GPIOA0	PWM0	28	Defaults to A0
GPIOA1	PWM1	27	Defaults to A1
GPIOA2	PWM2	23	Defaults to A2
GPIOA3	PWM3		Not bonded out in 56F8014 Defaults to A3
GPIOA4	PWM4 / FAULT1 / T2	22	SIM register SIM_GPS is used to select between PWM4, FAULT1, and T2 Defaults to A4
GPIOA5	PWM5 / FAULT2 / T3	20	SIM register SIM_GPS is used to select between PWM5, FAULT2, and T3 Defaults to A5
GPIOA6	FAULT0		Not bonded out in 56F8014 Defaults to A6
GPIOA7	$\overline{\text{RESET}}$	16	Defaults to $\overline{\text{RESET}}$
GPIOB0	SCLK / SCL	21	SIM register SIM_GPS is used to select between SCLK and SCL Defaults to B0
GPIOB1	$\overline{\text{SS}}$ / SDA	1	SIM register SIM_GPS is used to select between $\overline{\text{SS}}$ and SDA Defaults to B1
GPIOB2	MISO / T2	18	SIM register SIM_GPS is used to select between MISO and T2 Defaults to B2
GPIOB3	MOSI / T3	17	SIM register SIM_GPS is used to select between MOSI and T3 Defaults to B3
GPIOB4	T0 / CLKO	19	SIM register SIM_GPS is used to select between T0 and CLKO Defaults to B4
GPIOB5	T1 / FAULT3	3	SIM register SIM_GPS is used to select between T1 and FAULT3 Defaults to B5

Table 8-2 GPIO External Signals Map (Continued)
Pins in shaded rows are not available in 56F8014

GPIO Function	Peripheral Function	LQFP Package Pin	Notes
GPIOB6	RXD / SDA / CLKIN	32	SIM register SIM_GPS is used to select between RXD and SDA. CLKIN functionality is enabled using the PLL Control Register within the OCCS block. Defaults to B6
GPIOB7	TXD / SCL	2	SIM register SIM_GPS is used to select between TXD and SCL. Defaults to B7
GPIOC0	ANA0	13	Defaults to ANA0
GPIOC1	ANA1	12	Defaults to ANA1
GPIOC2	ANA2 / V _{REFH}	11	Defaults to ANA2
GPIOC3	ANA3	10	Defaults to ANA3
GPIOC4	ANB0	4	Defaults to ANB0
GPIOC5	ANB1	5	Defaults to ANB1
GPIOC6	ANB2 / V _{REFL}	6	Defaults to ANB2
GPIOC7	ANB3	7	Defaults to ANB3
GPIOD0	TDI	29	Defaults to TDI
GPIOD1	TDO	31	Defaults to TDO
GPIOD2	TCK	15	Defaults to TCK
GPIOD3	TMS	30	Defaults to TMS

8.3 Reset Values

Tables 4-16 through 4-19 detail registers for the 56F8014; Figures 8-1 through 8-4 summarize register maps and reset values.

Add. Offset	Register Acronym		15	14	13	12	11	10	9	8	7	6	5	4	3	2	1	0	
\$0	GPIOA_PUPEN	R	0	0	0	0	0	0	0	0	PU								
		W																	
		RS	0	0	0	0	0	0	0	0	0	1	1	1	1	1	1	1	1
\$1	GPIOA_DATA	R	0	0	0	0	0	0	0	0	D								
		W																	
		RS	0	0	0	0	0	0	0	0	0	0	1	1	1	1	1	1	1
\$2	GPIOA_DDIR	R	0	0	0	0	0	0	0	0	DD								
		W																	
		RS	0	0	0	0	0	0	0	0	0	0	0	0	0	0	0	0	0
\$3	GPIOA_PEREN	R	0	0	0	0	0	0	0	0	PE								
		W																	
		RS	0	0	0	0	0	0	0	0	0	1	0	0	0	0	0	0	0
\$4	GPIOA_IASSRT	R	0	0	0	0	0	0	0	0	IA								
		W																	
		RS	0	0	0	0	0	0	0	0	0	0	0	0	0	0	0	0	0
\$5	GPIOA_IEN	R	0	0	0	0	0	0	0	0	IEN								
		W																	
		RS	0	0	0	0	0	0	0	0	0	0	0	0	0	0	0	0	0
\$6	GPIOA_IEPOL	R	0	0	0	0	0	0	0	0	IEPOL								
		W																	
		RS	0	0	0	0	0	0	0	0	0	0	0	0	0	0	0	0	0
\$7	GPIOA_IPEND	R	0	0	0	0	0	0	0	0	IPR								
		W																	
		RS	0	0	0	0	0	0	0	0	0	0	0	0	0	0	0	0	0
\$8	GPIOA_IEDGE	R	0	0	0	0	0	0	0	0	IES								
		W																	
		RS	0	0	0	0	0	0	0	0	0	0	0	0	0	0	0	0	0
\$9	GPIOA_PPOUTM	R	0	0	0	0	0	0	0	0	OEN								
		W																	
		RS	0	0	0	0	0	0	0	0	0	1	1	1	1	1	1	1	1
\$A	GPIOA_RDATA	R	0	0	0	0	0	0	0	0	RAW DATA								
		W																	
		RS	X	X	X	X	X	X	X	X	X	X	X	X	X	X	X	X	X
\$B	GPIOA_DRIVE	R	0	0	0	0	0	0	0	0	DRIVE								
		W																	
		RS	0	0	0	0	0	0	0	0	0	0	0	0	0	0	0	0	0

R	0	Read as 0
W		Reserved
RS		Reset

Figure 8-1 GPIOA Register Map Summary

Add. Offset	Register Acronym		15	14	13	12	11	10	9	8	7	6	5	4	3	2	1	0	
\$0	GPIOB_PUPEN	R	0	0	0	0	0	0	0	0	PU								
		W																	
		RS	0	0	0	0	0	0	0	0	0	1	1	1	1	1	1	1	1
\$1	GPIOB_DATA	R	0	0	0	0	0	0	0	0	D								
		W																	
		RS	0	0	0	0	0	0	0	0	0	1	1	1	1	1	1	1	1
\$2	GPIOB_DDIR	R	0	0	0	0	0	0	0	0	DD								
		W																	
		RS	0	0	0	0	0	0	0	0	0	0	0	0	0	0	0	0	0
\$3	GPIOB_PEREN	R	0	0	0	0	0	0	0	0	PE								
		W																	
		RS	0	0	0	0	0	0	0	0	0	0	0	0	0	0	0	0	0
\$4	GPIOB_IASSRT	R	0	0	0	0	0	0	0	0	IA								
		W																	
		RS	0	0	0	0	0	0	0	0	0	0	0	0	0	0	0	0	0
\$5	GPIOB_IEN	R	0	0	0	0	0	0	0	0	IEN								
		W																	
		RS	0	0	0	0	0	0	0	0	0	0	0	0	0	0	0	0	0
\$6	GPIOB_IEPOL	R	0	0	0	0	0	0	0	0	IEPOL								
		W																	
		RS	0	0	0	0	0	0	0	0	0	0	0	0	0	0	0	0	0
\$7	GPIOB_IPEND	R	0	0	0	0	0	0	0	0	IPR								
		W																	
		RS	0	0	0	0	0	0	0	0	0	0	0	0	0	0	0	0	0
\$8	GPIOB_IEDGE	R	0	0	0	0	0	0	0	0	IES								
		W																	
		RS	0	0	0	0	0	0	0	0	0	0	0	0	0	0	0	0	0
\$9	GPIOB_PPOUTM	R	0	0	0	0	0	0	0	0	OEN								
		W																	
		RS	0	0	0	0	0	0	0	0	0	1	1	1	1	1	1	1	1
\$A	GPIOB_RDATA	R	0	0	0	0	0	0	0	0	RAW DATA								
		W																	
		RS	X	X	X	X	X	X	X	X	X	X	X	X	X	X	X	X	X
\$B	GPIOB_DRIVE	R	0	0	0	0	0	0	0	0	DRIVE								
		W																	
		RS	0	0	0	0	0	0	0	0	0	0	0	0	0	0	0	0	0

R	0	Read as 0
W		Reserved
RS		Reset

Figure 8-2 GPIOB Register Map Summary

Add. Offset	Register Acronym		15	14	13	12	11	10	9	8	7	6	5	4	3	2	1	0	
\$0	GPIOC_PUPEN	R	0	0	0	0	0	0	0	0	PU								
		W																	
		RS	0	0	0	0	0	0	0	0	0	1	1	1	1	1	1	1	1
\$1	GPIOC_DATA	R	0	0	0	0	0	0	0	0	D								
		W																	
		RS	0	0	0	0	0	0	0	0	0	0	0	0	0	0	0	0	0
\$2	GPIOC_DDIR	R	0	0	0	0	0	0	0	0	DD								
		W																	
		RS	0	0	0	0	0	0	0	0	0	0	0	0	0	0	0	0	0
\$3	GPIOC_PEREN	R	0	0	0	0	0	0	0	0	PE								
		W																	
		RS	0	0	0	0	0	0	0	0	0	1	1	1	1	1	1	1	1
\$4	GPIOC_IASSRT	R	0	0	0	0	0	0	0	0	IA								
		W																	
		RS	0	0	0	0	0	0	0	0	0	0	0	0	0	0	0	0	0
\$5	GPIOC_IEN	R	0	0	0	0	0	0	0	0	IEN								
		W																	
		RS	0	0	0	0	0	0	0	0	0	0	0	0	0	0	0	0	0
\$6	GPIOC_IEPOL	R	0	0	0	0	0	0	0	0	IEPOL								
		W																	
		RS	0	0	0	0	0	0	0	0	0	0	0	0	0	0	0	0	0
\$7	GPIOC_IPEND	R	0	0	0	0	0	0	0	0	IPR								
		W																	
		RS	0	0	0	0	0	0	0	0	0	0	0	0	0	0	0	0	0
\$8	GPIOC_IEDGE	R	0	0	0	0	0	0	0	0	IES								
		W																	
		RS	0	0	0	0	0	0	0	0	0	0	0	0	0	0	0	0	0
\$9	GPIOC_PPOUTM	R	0	0	0	0	0	0	0	0	OEN								
		W																	
		RS	0	0	0	0	0	0	0	0	0	1	1	1	1	1	1	1	1
\$A	GPIOC_RDATA	R	0	0	0	0	0	0	0	0	RAW DATA								
		W																	
		RS	X	X	X	X	X	X	X	X	X	X	X	X	X	X	X	X	X
\$B	GPIOC_DRIVE	R	0	0	0	0	0	0	0	0	DRIVE								
		W																	
		RS	0	0	0	0	0	0	0	0	0	0	0	0	0	0	0	0	0

R	0	Read as 0
W		Reserved
RS		Reset

Figure 8-3 GPIOC Register Map Summary

Add. Offset	Register Acronym		15	14	13	12	11	10	9	8	7	6	5	4	3	2	1	0
\$0	GPIOD_PUPEN	R	0	0	0	0	0	0	0	0	0	0	0	0	PU			
		W																
		RS	0	0	0	0	0	0	0	0	0	0	0	0	1	1	1	1
\$1	GPIOD_DATA	R	0	0	0	0	0	0	0	0	0	0	0	0	D			
		W																
		RS	0	0	0	0	0	0	0	0	0	0	0	0	0	0	0	0
\$2	GPIOD_DDIR	R	0	0	0	0	0	0	0	0	0	0	0	0	DD			
		W																
		RS	0	0	0	0	0	0	0	0	0	0	0	0	0	0	0	0
\$3	GPIOD_PEREN	R	0	0	0	0	0	0	0	0	0	0	0	0	PE			
		W																
		RS	0	0	0	0	0	0	0	0	0	0	0	0	1	1	1	1
\$4	GPIOD_IASSRT	R	0	0	0	0	0	0	0	0	0	0	0	0	IA			
		W																
		RS	0	0	0	0	0	0	0	0	0	0	0	0	0	0	0	0
\$5	GPIOD_IEN	R	0	0	0	0	0	0	0	0	0	0	0	0	IEN			
		W																
		RS	0	0	0	0	0	0	0	0	0	0	0	0	0	0	0	0
\$6	GPIOD_IEPOL	R	0	0	0	0	0	0	0	0	0	0	0	0	IEPOL			
		W																
		RS	0	0	0	0	0	0	0	0	0	0	0	0	0	0	0	0
\$7	GPIOD_IPEND	R	0	0	0	0	0	0	0	0	0	0	0	0	IPR			
		W																
		RS	0	0	0	0	0	0	0	0	0	0	0	0	0	0	0	0
\$8	GPIOD_IEDGE	R	0	0	0	0	0	0	0	0	0	0	0	0	IES			
		W																
		RS	0	0	0	0	0	0	0	0	0	0	0	0	0	0	0	0
\$9	GPIOD_PPOUTM	R	0	0	0	0	0	0	0	0	0	0	0	0	OEN			
		W																
		RS	0	0	0	0	0	0	0	0	0	0	0	0	1	1	1	1
\$A	GPIOD_RDATA	R	0	0	0	0	0	0	0	0	0	0	0	0	RAW DATA			
		W																
		RS	X	X	X	X	X	X	X	X	X	X	X	X	X	X	X	X
\$B	GPIOD_DRIVE	R	0	0	0	0	0	0	0	0	0	0	0	0	DRIVE			
		W																
		RS	0	0	0	0	0	0	0	0	0	0	0	0	0	0	0	0

R	0	Read as 0
W		Reserved



Figure 8-4 GPIO Register Map Summary

Part 9 Joint Test Action Group (JTAG)

9.1 56F8014 Information

Please contact your Freescale sales representative or authorized distributor for device/package-specific BSDL information.

The $\overline{\text{TRST}}$ pin is not available in this package. The pin is tied to V_{DD} in the package.

The JTAG state machine is reset during POR and can also be reset via a soft reset by holding TMS high for five rising edges of TCK, as described in the **56F8000 Peripheral User Manual**.

Part 10 Specifications

10.1 General Characteristics

The 56F8014 is fabricated in high-density CMOS with 5V-tolerant TTL-compatible digital inputs. The term “5V-tolerant” refers to the capability of an I/O pin, built on a 3.3V-compatible process technology, to withstand a voltage up to 5.5V without damaging the device. Many systems have a mixture of devices designed for 3.3V and 5V power supplies. In such systems, a bus may carry both 3.3V- and 5V-compatible I/O voltage levels (a standard 3.3V I/O is designed to receive a maximum voltage of $3.3\text{V} \pm 10\%$ during normal operation without causing damage). This 5V-tolerant capability therefore offers the power savings of 3.3V I/O levels, combined with the ability to receive 5V levels without damage.

Absolute maximum ratings in **Table 10-1** are stress ratings only, and functional operation at the maximum is not guaranteed. Stress beyond these ratings may affect device reliability or cause permanent damage to the device.

Unless otherwise stated, all specifications within this chapter apply over the temperature range of -40°C to 125°C ambient temperature over the following supply ranges:

$$V_{\text{SS}} = V_{\text{SSA}} = 0\text{V}, V_{\text{DD}} = V_{\text{DDA}} = 3.0\text{--}3.6\text{V}, C_{\text{L}} \leq 50\text{pF}, f_{\text{OP}} = 32\text{MHz}$$

CAUTION

This device contains protective circuitry to guard against damage due to high static voltage or electrical fields. However, normal precautions are advised to avoid application of any voltages higher than maximum-rated voltages to this high-impedance circuit. Reliability of operation is enhanced if unused inputs are tied to an appropriate voltage level.

Table 10-1 Absolute Maximum Ratings

($V_{SS} = 0V$, $V_{SSA} = 0V$)

Characteristic	Symbol	Notes	Min	Max	Unit
Supply Voltage Range	V_{DD}		-0.3	4.0	V
Analog Supply Voltage Range	V_{DDA}		- 0.3	4.0	V
ADC High Voltage Reference	V_{REFH}		- 0.3	4.0	V
Voltage difference V_{DD_IO} to V_{DDA}	ΔV_{DD}		- 0.3	0.3	V
Voltage difference V_{SS_IO} to V_{SSA}	ΔV_{SS}		- 0.3	0.3	V
Input Voltage Range (Digital inputs)	V_{IN}	Pin Groups 1, 2	- 0.3	6.0	V
Input Voltage Range (ADC inputs) ¹	V_{INA}	Pin Group 3	- 0.3	4.0	V
Input clamp current, per pin ($V_{IN} < 0$) ²	V_{IC}		-	-20	mA
Output clamp current, per pin ($V_O < 0$) ²	V_{OC}		-	-20	mA
Output Voltage Range (Normal Push-Pull mode)	V_{OUT}	Pin Group 1	-0.3	4.0	V
Output Voltage Range (Open Drain mode)	V_{OUTOD}	Pin Groups 1, 2	-0.3	6.0	V
Ambient Temperature (Automotive)	T_A		-40	125	°C
Ambient Temperature (Industrial)	T_A		-40	105	°C
Junction Temperature (Automotive)	T_J		-40	150	°C
Junction Temperature (Industrial)	T_J		-40	125	°C
Storage Temperature (Automotive)	T_{STG}		-55	150	°C
Storage Temperature (Industrial)	T_{STG}		-55	150	°C

1. Pin Group 3 can tolerate 6V for less than 5 seconds when they are configured as ADC inputs or during reset. Pin Group 3 can tolerate 6V if they are configured as GPIO.
2. Continuous input current per pin is -2 mA

Default Mode

Pin Group 1: GPIO, TDI, TDO, TMS, TCK

Pin Group 2: $\overline{\text{RESET}}$, GPIOA7

Pin Group 3: ADC analog inputs

10.1.1 ElectroStatic Discharge (ESD) Model

Table 10-2 56F8014 ESD Protection

Characteristic	Min	Typ	Max	Unit
ESD for Human Body Model (HBM)	2000	—	—	V
ESD for Machine Model (MM)	200	—	—	V
ESD for Charge Device Model (CDM)	750	—	—	V

Table 10-3 LQFP Package Thermal Characteristics⁶

Characteristic	Comments	Symbol	Value (LQFP)	Unit	Notes
Junction to ambient Natural convection	Single layer board (1s)	$R_{\theta JA}$	74	°C/W	1,2
Junction to ambient Natural convection	Four layer board (2s2p)	$R_{\theta JMA}$	50	°C/W	1,3
Junction to ambient (@200 ft/min)	Single layer board (1s)	$R_{\theta JMA}$	67	°C/W	1,3
Junction to ambient (@200 ft/min)	Four layer board (2s2p)	$R_{\theta JMA}$	46	°C/W	1,3
Junction to board		$R_{\theta JB}$	23	°C/W	4
Junction to case		$R_{\theta JC}$	20	°C/W	5
Junction to package top	Natural Convection	Ψ_{JT}	4	°C/W	6

1. Junction temperature is a function of die size, on-chip power dissipation, package thermal resistance, mounting site (board) temperature, ambient temperature, air flow, power dissipation of other components on the board, and board thermal resistance.
2. Per SEMI G38-87 and JEDEC JESD51-2 with the single layer board horizontal.
3. Per JEDEC JESD51-6 with the board horizontal.
4. Thermal resistance between the die and the printed circuit board per JEDEC JESD51-8. Board temperature is measured on the top surface of the board near the package.

5. Thermal resistance between the die and the case top surface as measured by the cold plate method (MIL SPEC-883 Method 1012.1).
6. Thermal characterization parameter indicating the temperature difference between package top and the junction temperature per JEDEC JESD51-2. When Greek letters are not available, the thermal characterization parameter is written as Psi-JT.
7. See [Section 12.1](#) for more details on thermal design considerations.

Table 10-4 Recommended Operating Conditions

 ($V_{REFL} = 0V$, $V_{SSA} = 0V$, $V_{SS} = 0V$)

Characteristic	Symbol	Notes	Min	Typ	Max	Unit
Supply voltage	V_{DD}		3	3.3	3.6	V
ADC Supply voltage	V_{DDA}		3	3.3	3.6	V
ADC High Voltage Reference	V_{REFH}		3	—	V_{DDA}	V
Voltage difference V_{DD_IO} to V_{DDA}	ΔV_{DD}		-0.1	0	0.1	V
Voltage difference V_{SS_IO} to V_{SSA}	ΔV_{SS}		-0.1	0	0.1	V
Device Clock Frequency Using relaxation oscillator Using external clock source	FSYSCLK		8 0	—	32 32	MHz
Input Voltage High (digital inputs)	V_{IH}	Pin Groups 1, 2	2	—	5.5	V
Input Voltage Low (digital inputs)	V_{IL}	Pin Groups 1, 2	-0.3	—	0.8	V
Output Source Current High (at V_{OH} min.) When programmed for low drive strength When programmed for high drive strength	I_{OH}	Pin Group 1 Pin Group 1	— —	— —	-4 -8	mA
Output Source Current Low (at V_{OL} max.) When programmed for low drive strength When programmed for high drive strength	I_{OL}	Pin Groups 1, 2 Pin Groups 1, 2	— —	— —	4 8	mA
Ambient Operating Temperature (Automotive)	T_A		-40	—	125	°C
Ambient Operating Temperature (Industrial)	T_A		-40	—	105	°C
Flash Endurance (Automotive) (Program Erase Cycles)	N_F	$T_A = -40^{\circ}C$ to $125^{\circ}C$	10,000	—	—	Cycles
Flash Endurance (Industrial) (Program Erase Cycles)	N_F	$T_A = -40^{\circ}C$ to $105^{\circ}C$	10,000	—	—	Cycles
Flash Data Retention	T_R	$T_J \leq 85^{\circ}C$ avg	15	—	—	Years
Flash Data Retention with <100 Program/Erase Cycles	t_{FLRET}	$T_J \leq 85^{\circ}C$ avg	20	—	—	Years

Note: Total chip source or sink current cannot exceed 50mA

Default Mode

Pin Group 1: GPIO, TDI, TDO, TMS, TCK

Pin Group 2: \overline{RESET} , GPIOA7

Pin Group 3: ADC analog inputs

10.2 DC Electrical Characteristics

Table 10-5 DC Electrical Characteristics
At Recommended Operating Conditions

Characteristic	Symbol	Notes	Min	Typ	Max	Unit	Test Conditions
Output Voltage High	V_{OH}	Pin Group 1	2.4	—	—	V	$I_{OH} = I_{OHmax}$
Output Voltage Low	V_{OL}	Pin Groups 1, 2	—	—	0.4	V	$I_{OL} = I_{OLmax}$
Digital Input Current High pull-up enabled or disabled ¹	I_{IH}	Pin Groups 1, 2	—	0	+/- 2.5	μA	$V_{IN} = 2.4V$ to 5.5V
Digital Input Current Low pull-up enabled pull-up disabled ¹	I_{IL}	Pin Groups 1, 2	-15 —	-30 0	-60 +/- 2.5	μA	$V_{IN} = 0V$
Output Current High Impedance State ¹	I_{OZ}	Pin Groups 1, 2	—	0	+/- 2.5	μA	$V_{OUT} = 2.4V$ to 5.5V or 0V
Schmitt Trigger Input Hysteresis	V_{HYS}	Pin Groups 1, 2	—	0.35	—	V	—
Input Capacitance	C_{IN}		—	10	—	pF	—
Output Capacitance	C_{OUT}		—	10	—	pF	—

1. See [Figure 10-1](#)

Default Mode

Pin Group 1: GPIO, TDI, TDO, TMS, TCK

Pin Group 2: \overline{RESET} , GPIOA7

Pin Group 3: ADC analog inputs

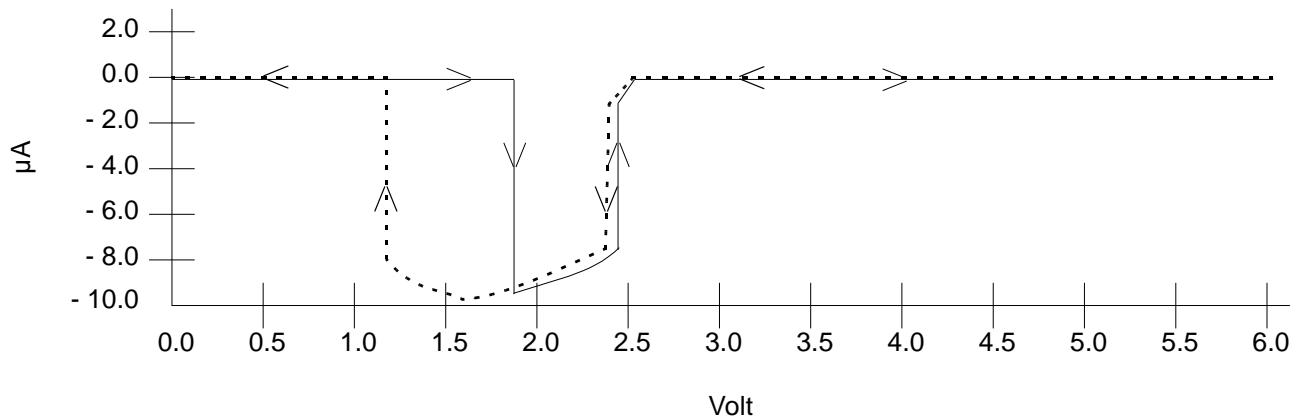

Figure 10-1 I_{IN}/I_{OZ} vs. V_{IN} (Typical; Pull-Up Disabled)

Table 10-6 Current Consumption per Power Supply Pin (Typical)

Mode	Conditions	Typical @ 3.3V, 25°C		Maximum @ 3.6V, 25°C	
		I _{DD} ¹	I _{DDA}	I _{DD} ¹	I _{DDA}
RUN	32MHz Device Clock Relaxation Oscillator on PLL powered on Continuous MAC instructions with fetches from Program Flash All peripheral modules enabled. Quad Timer and PWM using 1x Clock ADC powered on and clocked	42mA	13.5mA	—	—
WAIT	32MHz Device Clock Relaxation Oscillator on PLL powered on Processor Core in WAIT state All Peripheral modules enabled. Quad Timer and PWM using 1x Clock ADC powered off	17mA	0μA	—	—
STOP	4MHz Device Clock Relaxation Oscillator on PLL powered off Processor Core in STOP state All peripheral module and core clocks are off ADC powered off	5mA	0μA	—	—
STANDBY > STOP	100KHz Device Clock Relaxation Oscillator in Standby mode PLL powered off Processor Core in STOP state All peripheral module and core clocks are off ADC powered off Voltage regulator in Standby mode	430μA	0μA	550μA	1μA
POWERDOWN	Device Clock is off Relaxation Oscillator powered off PLL powered off Processor Core in STOP state All peripheral module and core clocks are off ADC powered off Voltage Regulator in Standby mode	300μA	0μA	400μA	1μA

1. No Output Switching
 All ports configured as inputs
 All inputs Low
 No DC Loads

Table 10-7 Power-On Reset Low-Voltage Parameters

Characteristic	Symbol	Min	Typ	Max	Unit
Low-Voltage Interrupt for 3.3V supply ¹	$V_{EI3.3}$	2.60	2.7	—	V
Low-Voltage Interrupt for 2.5V supply ²	$V_{EI2.5}$	2.05	2.15	—	V
Low-Voltage Interrupt Recovery Hysteresis	V_{EIH}	—	50	—	mV
Power-On Reset ³	POR	—	1.8	1.9	V

1. When V_{DD} drops below $V_{EI3.3}$, an interrupt is generated.
2. When V_{DD} drops below $V_{EI2.5}$, an interrupt is generated.
3. Power-On Reset occurs whenever the internally regulated 2.5V digital supply drops below 1.8V. While power is ramping up, this signal remains active for as long as the internal 2.5V is below 2.15V or the 3.3V I/O voltage is below 2.7V, no matter how long the ramp-up rate is. The internally regulated voltage is typically 100mV less than V_{DD} during ramp-up until 2.5V is reached, at which time it self-regulates.

10.2.1 Voltage Regulator Specifications

The 56F8014 has two on-chip regulators. One supplies the PLL and relaxation oscillator. It has no external pins and therefore has no external characteristics which must be guaranteed (other than proper operation of the device). The second regulator supplies approximately 2.5 V to the 56F8014's core logic. This regulator requires an external 2.2 μ F, or greater, capacitor for proper operation. Ceramic and tantalum capacitors tend to provide better performance tolerances. The output voltage can be measured directly on the V_{CAP} pin. The specifications for this regulator are shown in [Table 10-8](#).

Table 10-8. Regulator Parameters

Characteristic	Symbol	Min	Typical	Max	Unit
Input Voltage	V_{IN}	3.0	—	3.6	V
Output Voltage	V_{OUT}	2.25	2.5	2.75	V
Short Circuit Current	I_{SS}	—	450	650	mA
Short Circuit Tolerance (output shorted to ground)	T_{RSC}	—	—	30	Minutes

10.3 AC Electrical Characteristics

Tests are conducted using the input levels specified in [Table 10-5](#). Unless otherwise specified, propagation delays are measured from the 50% to the 50% point, and rise and fall times are measured between the 10% and 90% points, as shown in [Figure 10-2](#).

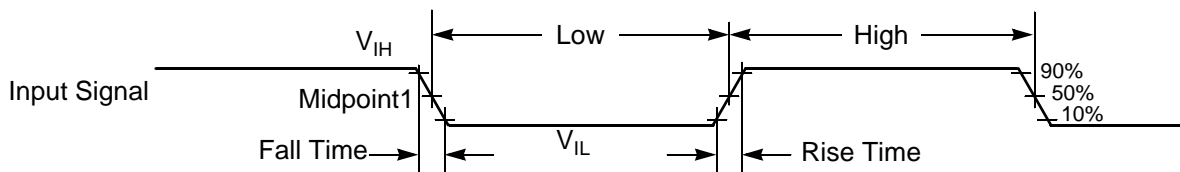

Note: The midpoint is $V_{IL} + (V_{IH} - V_{IL})/2$.

Figure 10-2 Input Signal Measurement References

Figure 10-3 shows the definitions of the following signal states:

- Active state, when a bus or signal is driven, and enters a low impedance state
- Tri-stated, when a bus or signal is placed in a high impedance state
- Data Valid state, when a signal level has reached V_{OL} or V_{OH}
- Data Invalid state, when a signal level is in transition between V_{OL} and V_{OH}

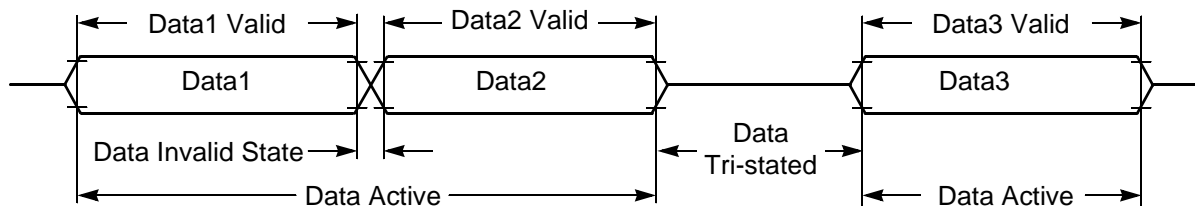

Figure 10-3 Signal States

10.4 Flash Memory Characteristics

Table 10-9 Flash Timing Parameters

Characteristic	Symbol	Min	Typ	Max	Unit
Program time ¹	T_{prog}	20	—	40	μs
Erase time ²	T_{erase}	20	—	—	ms
Mass erase time	T_{me}	100	—	—	ms

1. There is additional overhead which is part of the programming sequence. See the **56F801X Peripheral Reference Manual** for details.

2. Specifies page erase time. There are 512 bytes per page in the Program Flash memory.

10.5 External Clock Operation Timing

Table 10-10 External Clock Operation Timing Requirements¹

Characteristic	Symbol	Min	Typ	Max	Unit
Frequency of operation (external clock driver) ²	f_{osc}	4	8	8	MHz
Clock Pulse Width ³	t_{PW}	6.25	—	—	ns
External Clock Input Rise Time ⁴	t_{rise}	—	—	3	ns
External Clock Input Fall Time ⁵	t_{fall}	—	—	3	ns

- Parameters listed are guaranteed by design.
- See [Figure 10-4](#) for details on using the recommended connection of an external clock driver.
- The high or low pulse width must be no smaller than 6.25ns or the chip may not function.
- External clock input rise time is measured from 10% to 90%.
- External clock input fall time is measured from 90% to 10%.

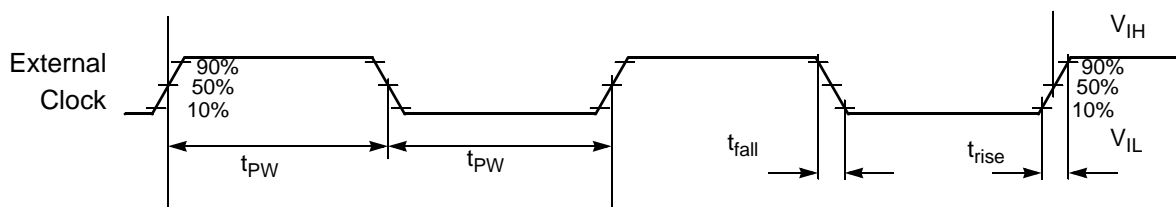

Note: The midpoint is $V_{IL} + (V_{IH} - V_{IL})/2$.

Figure 10-4 External Clock Timing

10.6 Phase Locked Loop Timing

Table 10-11 PLL Timing

Characteristic	Symbol	Min	Typ	Max	Unit
Internal reference relaxation oscillator frequency for the PLL	f_{rosc}	—	8	—	MHz
PLL output frequency ¹ (24 x reference frequency)	f_{op}	—	192	—	MHz
PLL lock time ²	t_{lock}	—	40	100	μ s
Cycle to cycle jitter	$t_{jitterpll}$		350		ps

- The core system clock will operate at 1/6 of the PLL output frequency.
- This is the time required after the PLL is enabled to ensure reliable operation.

10.7 Relaxation Oscillator Timing

Table 10-12 Relaxation Oscillator Timing

Characteristic	Symbol	Minimum	Typical	Maximum	Unit
Relaxation Oscillator output frequency Normal Mode ¹ Standby Mode	f_{op}	—	8.05 200	—	MHz kHz
Relaxation Oscillator stabilization time ²	t_{roscs}	—	1	3	μ s
Cycle-to-cycle jitter. This is measured on the CLKO signal (programmed prescaler_clock) over 264 clocks ³	$t_{jitterosc}$	—	400		ps
Minimum tuning step size			.08		%
Maximum tuning step size			40		%
Variation over temperature -40°C to 150°C ⁴			+1.0 to -1.5	+3.0 to -3.0	%
Variation over temperature 0°C to 105°C ⁴			0 to +1	+2.0 to -2.0	%

1. Output frequency after factory trim.
2. This is the time required from standby to normal mode transition.
3. J_A is required to meet SCI requirements.
4. See [Figure 10-5](#).

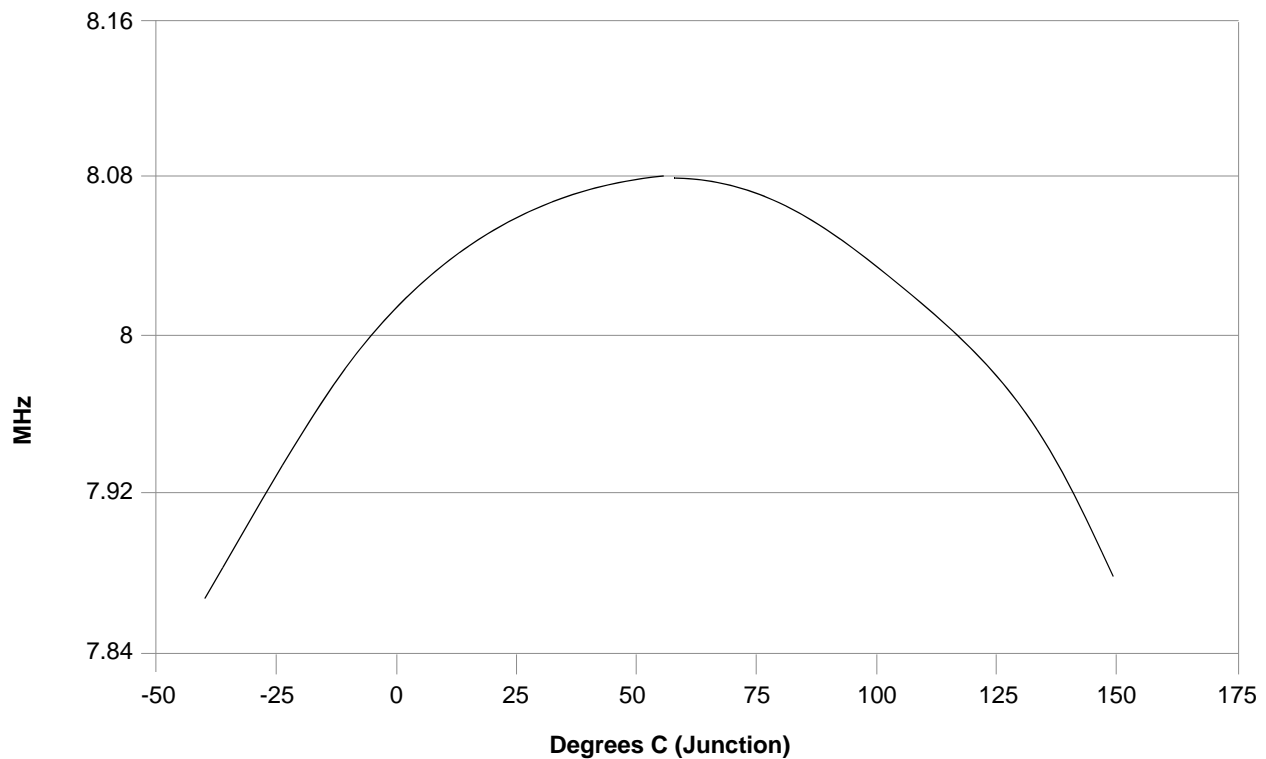

Figure 10-5 Relaxation Oscillator Temperature Variation (Typical) After Trim

10.8 Reset, Stop, Wait, Mode Select, and Interrupt Timing

Note: All the address and data buses described here are internal.

Table 10-13 Reset, Stop, Wait, Mode Select, and Interrupt Timing^{1,2}

Characteristic	Symbol	Typical Min	Typical Max	Unit	See Figure
Minimum $\overline{\text{RESET}}$ Assertion Duration	t_{RA}	4T	—	ns	
Minimum GPIO pin Assertion for Interrupt	t_{IW}	2T	—	ns	10-6
$\overline{\text{RESET}}$ deassertion to First Address Fetch ³	t_{RDA}	$96T_{\text{OSC}} + 64T$	$97T_{\text{OSC}} + 65T$	ns	
Delay from Interrupt Assertion to Fetch of first instruction (exiting Stop)	t_{IF}	—	6T	ns	

1. In the formulas, T = clock cycle and T_{OSC} = oscillator clock cycle. For an operating frequency of 32MHz, T = 31.25ns. At 8MHz (used during Reset and Stop modes), T = 125ns.

2. Parameters listed are guaranteed by design.

3. During Power-On Reset, it is possible to use the 56F8014 internal reset stretching circuitry to extend this period to $2^{\wedge}21T$.

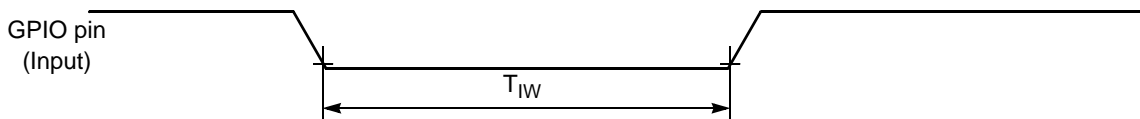

Figure 10-6 GPIO Interrupt Timing (Negative Edge-Sensitive)

10.9 Serial Peripheral Interface (SPI) Timing

Table 10-14 SPI Timing¹

Characteristic	Symbol	Min	Max	Unit	See Figure
Cycle time Master Slave	t_C	125 62.5	— —	ns ns	10-7 , 10-8 , 10-9 , 10-10
Enable lead time Master Slave	t_{ELD}	— 31	— —	ns ns	10-10
Enable lag time Master Slave	t_{ELG}	— 125	— —	ns ns	10-10
Clock (SCK) high time Master Slave	t_{CH}	50 31	— —	ns ns	10-7 , 10-8 , 10-9 , 10-10
Clock (SCK) low time Master Slave	t_{CL}	50 31	— —	ns ns	10-10
Data set-up time required for inputs Master Slave	t_{DS}	20 0	— —	ns ns	10-7 , 10-8 , 10-9 , 10-10
Data hold time required for inputs Master Slave	t_{DH}	0 2	— —	ns ns	10-7 , 10-8 , 10-9 , 10-10
Access time (time to data active from high-impedance state) Slave	t_A	4.8	15	ns	10-10
Disable time (hold time to high-impedance state) Slave	t_D	3.7	15.2	ns	10-10
Data Valid for outputs Master Slave (after enable edge)	t_{DV}	— —	4.5 20.4	ns ns	10-7 , 10-8 , 10-9 , 10-10
Data invalid Master Slave	t_{DI}	0 0	— —	ns ns	10-7 , 10-8 , 10-9 , 10-10
Rise time Master Slave	t_R	— —	11.5 10.0	ns ns	10-7 , 10-8 , 10-9 , 10-10
Fall time Master Slave	t_F	— —	9.7 9.0	ns ns	10-7 , 10-8 , 10-9 , 10-10

1. Parameters listed are guaranteed by design.

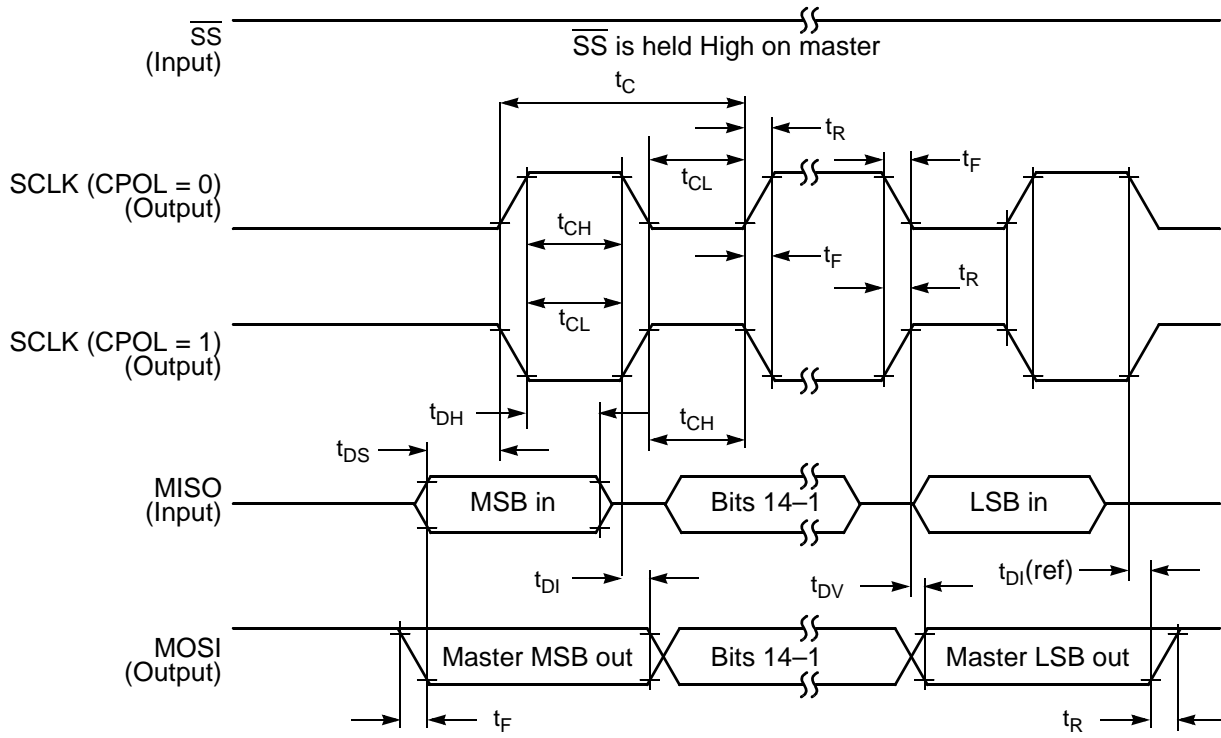

Figure 10-7 SPI Master Timing (CPHA = 0)

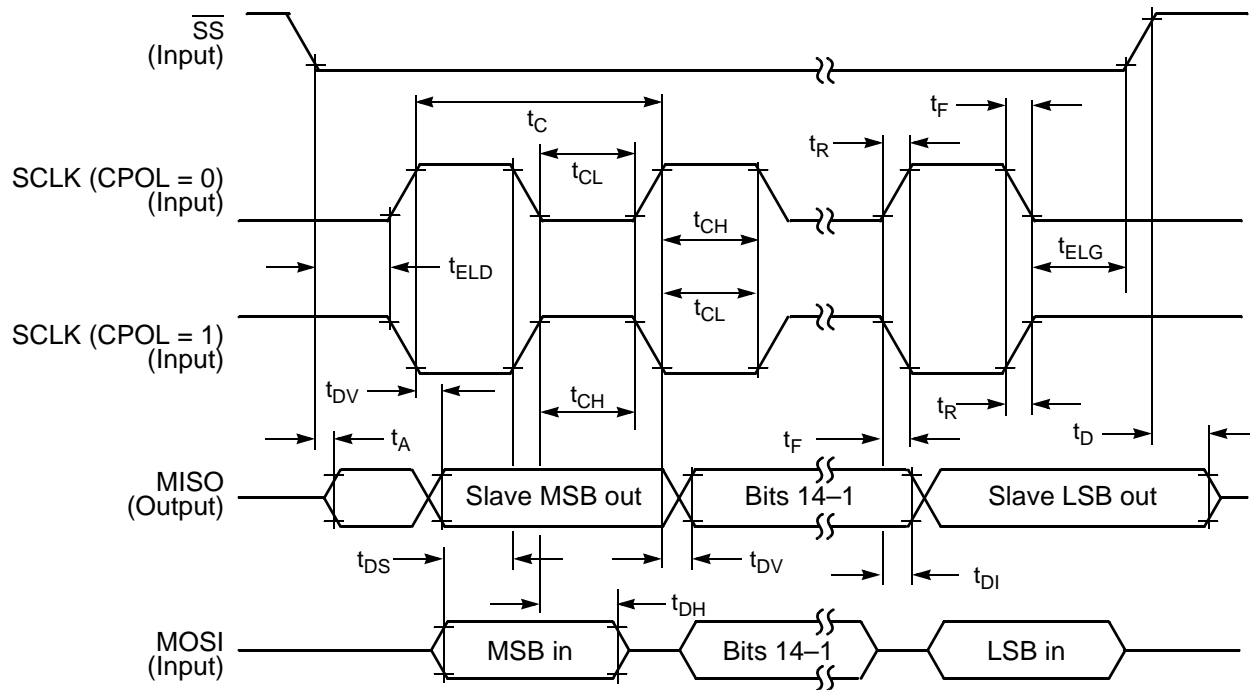

Figure 10-10 SPI Slave Timing (CPHA = 1)

10.10 Quad Timer Timing

Table 10-15 Timer Timing^{1, 2}

Characteristic	Symbol	Min	Max	Unit	See Figure
Timer input period	P_{IN}	$2T + 6$	—	ns	10-11
Timer input high / low period	P_{INHL}	$1T + 3$	—	ns	10-11
Timer output period	P_{OUT}	125	—	ns	10-11
Timer output high / low period	P_{OUTHL}	50	—	ns	10-11

1. In the formulas listed, T = the clock cycle. For 32MHz operation, T = 31.25ns.

2. Parameters listed are guaranteed by design.

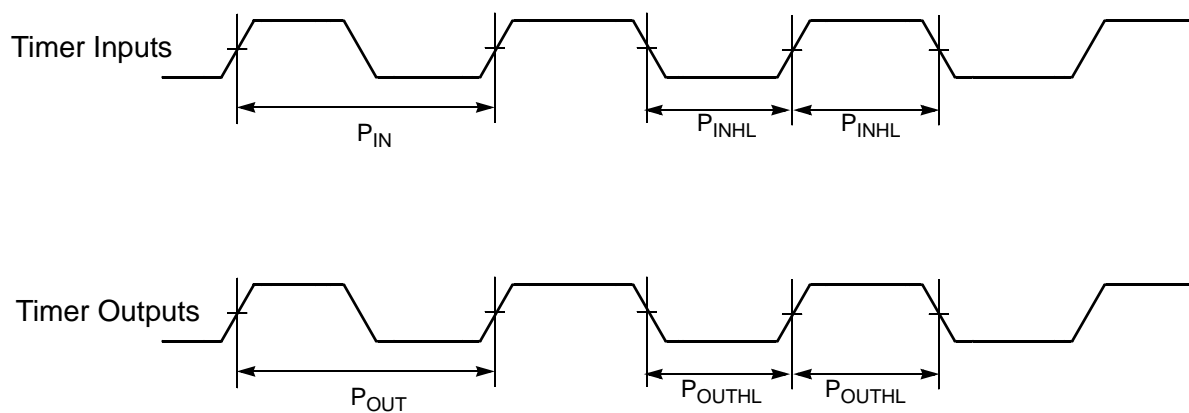

Figure 10-11 Timer Timing

10.11 Serial Communication Interface (SCI) Timing

Table 10-16 SCI Timing¹

Characteristic	Symbol	Min	Max	Unit	See Figure
Baud Rate ²	BR	—	($f_{MAX}/16$)	Mbps	—
RXD ³ Pulse Width	RXD _{PW}	0.965/BR	1.04/BR	ns	10-12
TXD ⁴ Pulse Width	TXD _{PW}	0.965/BR	1.04/BR	ns	10-13
LIN Slave Mode					
Deviation of slave node clock from nominal clock rate before synchronization	F _{TOL_UNSYNCH}	-14	14	%	
Deviation of slave node clock relative to the master node clock after synchronization	F _{TOL_SYNCH}	-2	2	%	
Minimum break character length	T _{BREAK}	13		Master node bit periods	
		11		Slave node bit periods	

1. Parameters listed are guaranteed by design.

2. f_{MAX} is the frequency of operation of the system clock in MHz, which is 32MHz for the 56F8014 device.

3. The RXD pin in SCI0 is named RXD0 and the RXD pin in SCI1 is named RXD1.

4. The TXD pin in SCI0 is named TXD0 and the TXD pin in SCI1 is named TXD1.



Figure 10-12 RXD Pulse Width



Figure 10-13 TXD Pulse Width

10.12 Inter-Integrated Circuit Interface (I²C) Timing

Table 10-17 I²C Timing

Characteristic	Symbol	Standard Mode		Fast Mode		Unit
		Minimum	Maximum	Minimum	Maximum	
SCL Clock Frequency	f_{SCL}	0	100	0	400	kHz
Hold time (repeated) START condition. After this period, the first clock pulse is generated.	$t_{HD; STA}$	4.0		0.6		μs
LOW period of the SCL clock	t_{LOW}	4.7		1.25		μs
HIGH period of the SCL clock	t_{HIGH}	4.0		0.6		μs
Set-up time for a repeated START condition	$t_{SU; STA}$	4.7		0.6		μs
Data hold time for I ² C bus devices	$t_{HD; DAT}$	0 ¹	3.45 ²	0 ¹	0.9 ²	μs
Data set-up time	$t_{SU; DAT}$	250		100 ³		ns
Rise time of both SDA and SCL signals	t_r		1000	$2 + 0.1C_b^4$	300	ns
Fall time of both SDA and SCL signals	t_f		300	$2 + 0.1C_b^4$	300	ns
Set-up time for STOP condition	$t_{SU; STO}$	4.0		0.6		μs
Bus free time between STOP and START condition	t_{BUF}	4.7		1.3		μs
Pulse width of spikes that must be suppressed by the input filter	t_{SP}	N/A	N/A	0.0	50	ns

1. A device must internally provide a hold time of at least 300ns for the SDA signal (referred to the V_{IH} min of the SCL signal) to bridge the undefined region of the falling edge of SCL.
2. The maximum $t_{HD; DAT}$ has only to be met if the device does not stretch the LOW period (t_{LOW}) of the SCL signal.
3. A Fast mode I²C bus device can be used in a Standard mode I²C bus system, but the requirement $t_{SU; DAT} \geq 250ns$ must then be met. This will automatically be the case if the device does not stretch the LOW period of the SCL signal. If such a device does stretch the LOW period of the SCL signal, it must output the next data bit to the SDA line
 $t_{rmax} + t_{SU; DAT} = 1000 + 250 = 1250ns$ (according to the Standard mode I²C bus specification) before the SCL line is released.
4. C_b = total capacitance of the one bus line in pF.

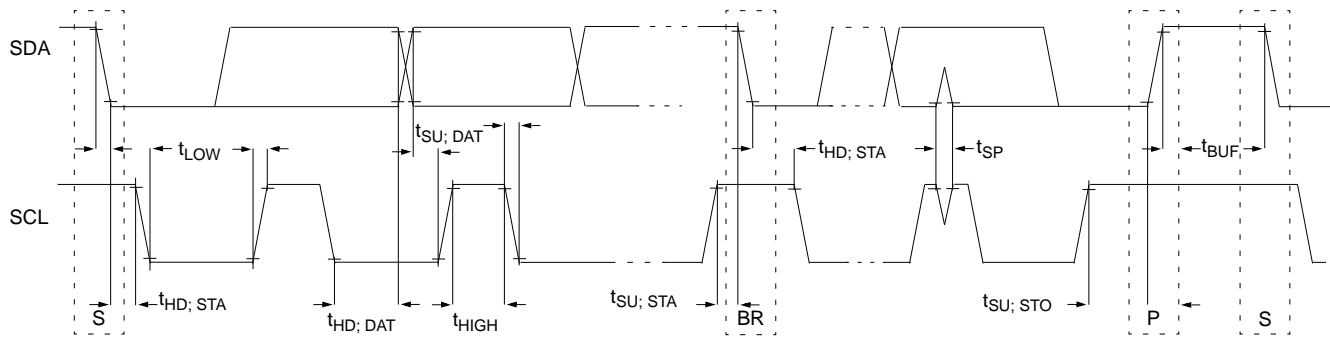

Figure 10-14 Timing Definition for Fast and Standard Mode Devices on the I²C Bus

10.13 JTAG Timing

Table 10-18 JTAG Timing

Characteristic	Symbol	Min	Max	Unit	See Figure
TCK frequency of operation ¹	f_{OP}	DC	SYS_CLK/8	MHz	10-15
TCK clock pulse width	t_{PW}	50	—	ns	10-15
TMS, TDI data set-up time	t_{DS}	5	—	ns	10-16
TMS, TDI data hold time	t_{DH}	5	—	ns	10-16
TCK low to TDO data valid	t_{DV}	—	30	ns	10-16
TCK low to TDO tri-state	t_{TS}	—	30	ns	10-16

1. TCK frequency of operation must be less than 1/8 the processor rate.

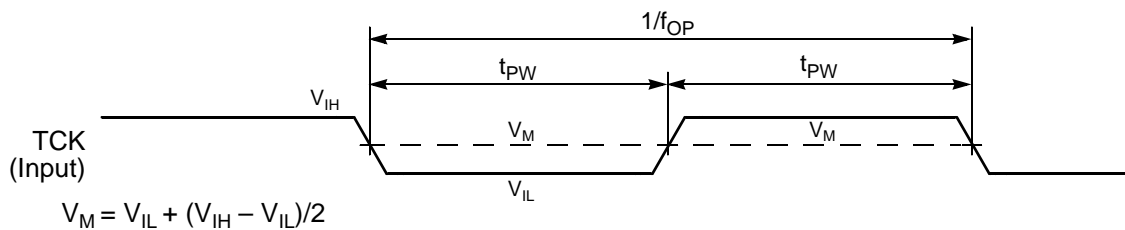

Figure 10-15 Test Clock Input Timing Diagram

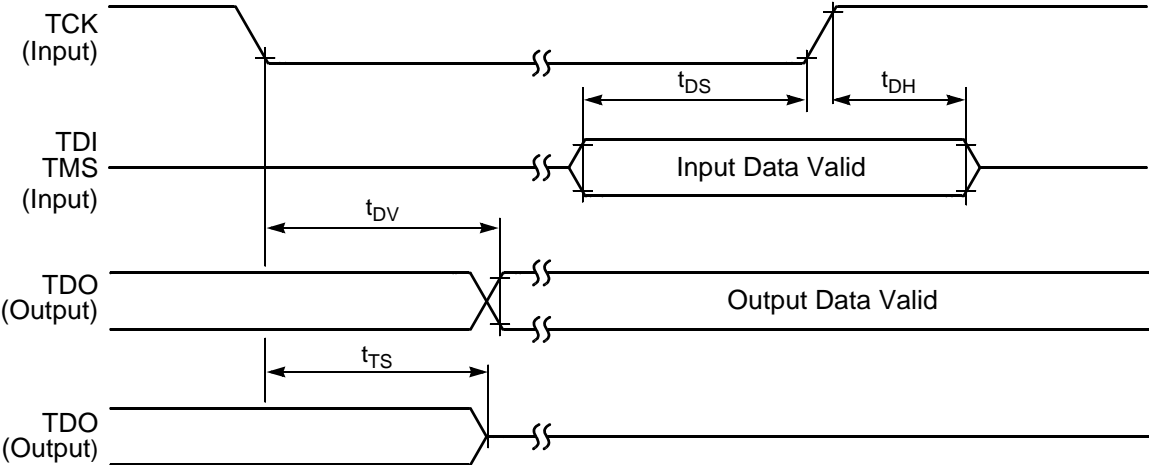

Figure 10-16 Test Access Port Timing Diagram

10.14 Analog-to-Digital Converter (ADC) Parameters

Table 10-19 ADC Parameters¹

Parameter	Symbol	Min	Typ	Max	Unit
DC Specifications					
Resolution	R_{ES}	12	—	12	Bits
ADC internal clock	f_{ADIC}	0.1	—	5.33	MHz
Conversion range	R_{AD}	V_{REFL}	—	V_{REFH}	V
ADC power-up time ²	t_{ADPU}	—	6	13	t_{AIC} cycles ³
Recovery from auto standby	t_{REC}	—	0	1	t_{AIC} cycles ³
Conversion time	t_{ADC}	—	6	—	t_{AIC} cycles ³
Sample time	t_{ADS}	—	1	—	t_{AIC} cycles ³
Accuracy					
Integral non-linearity ⁴ (Full input signal range)	INL	—	+/- 3	+/- 5	LSB ⁵
Differential non-linearity	DNL	—	+/- .6	+/- 1	LSB ⁵
Monotonicity	GUARANTEED				
Offset Voltage Internal Ref	V_{OFFSET}	—	+/- 4	+/- 9	mV
Offset Voltage External Ref	V_{OFFSET}	—	+/- 6	+/- 12	mV
Gain Error (transfer gain)	E_{GAIN}	—	.998 to 1.002	1.01 to .99	—
ADC Inputs⁶ (Pin Group 3)					
Input voltage (external reference)	V_{ADIN}	V_{REFL}	—	V_{REFH}	V
Input voltage (internal reference)	V_{ADIN}	V_{SSA}	—	V_{DDA}	V
Input leakage	I_{IA}	—	0	+/- 2	μ A
V_{REFH} current	I_{VREFH}	—	0	—	μ A
Input injection current ⁷ , per pin	I_{ADI}	—	—	3	mA
Input capacitance	C_{ADI}	—	See Figure 10-17	—	pF
Input impedance	X_{IN}	—	See Figure 10-17	—	Ohms
AC Specifications					
Signal-to-noise ratio	SNR	60	65		dB
Total Harmonic Distortion	THD	60	64		dB
Spurious Free Dynamic Range	SFDR	61	66		dB
Signal-to-noise plus distortion	SINAD	58	62		dB
Effective Number Of Bits	ENOB	—	10.0		Bits

1. All measurements were made at $V_{DD} = 3.3V$, $V_{REFH} = 3.3V$, and $V_{REFL} = \text{ground}$

2. Includes power-up of ADC and V_{REF}

3. ADC clock cycles

4. INL measured from $V_{IN} = V_{REFL}$ to $V_{IN} = V_{REFH}$

5. LSB = Least Significant Bit = 0.806mV
6. Pin groups are detailed following [Table 10-1](#).
7. The current that can be injected or sourced from an unselected ADC signal input without impacting the performance of the ADC.

10.15 Equivalent Circuit for ADC Inputs

Figure 10-17 illustrates the ADC input circuit during sample and hold. S1 and S2 are always open/closed at the same time that S3 is closed/open. When S1/S2 are closed & S3 is open, one input of the sample and hold circuit moves to $(V_{REFH}-V_{REFL})/2$, while the other charges to the analog input voltage. When the switches are flipped, the charge on C1 and C2 are averaged via S3, with the result that a single-ended analog input is switched to a differential voltage centered about $(V_{REFH}-V_{REFL})/2$. The switches switch on every cycle of the ADC clock (open one-half ADC clock, closed one-half ADC clock). Note that there are additional capacitances associated with the analog input pad, routing, etc., but these do not filter into the S/H output voltage, as S1 provides isolation during the charge-sharing phase.

One aspect of this circuit is that there is an on-going input current, which is a function of the analog input voltage, V_{REF} and the ADC clock frequency.

Equivalent Circuit for A/D Loading

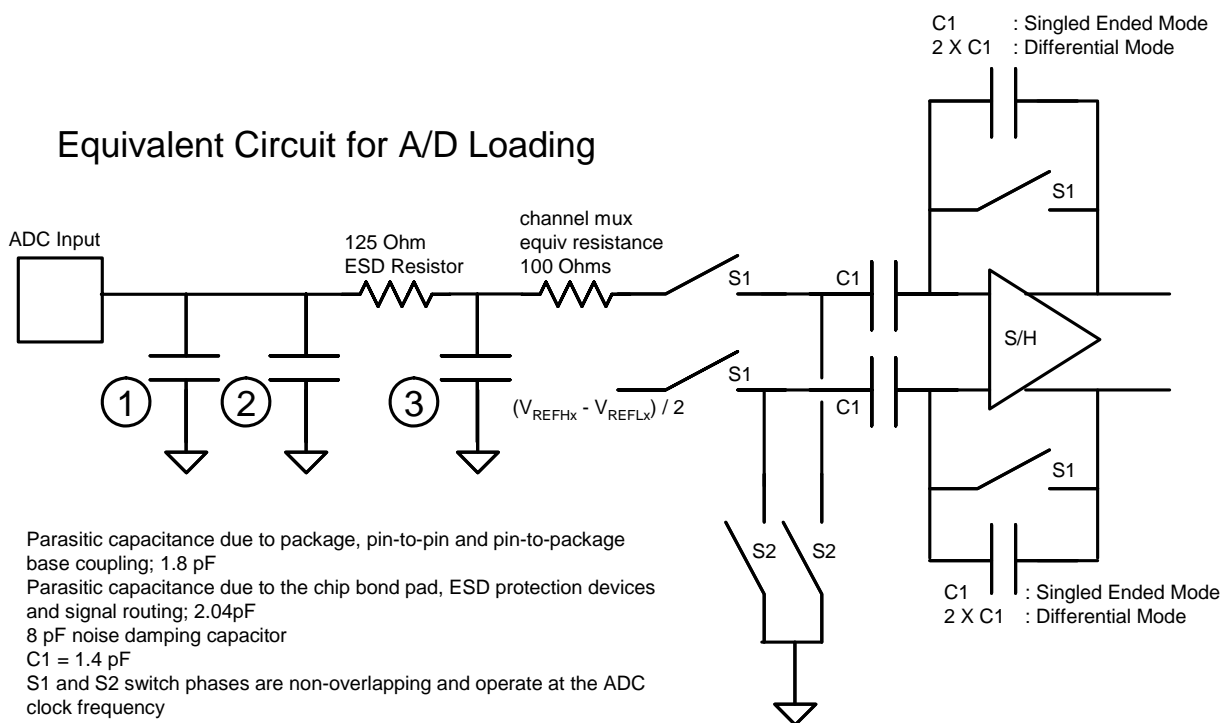

1. Parasitic capacitance due to package, pin-to-pin and pin-to-package base coupling; 1.8 pF
2. Parasitic capacitance due to the chip bond pad, ESD protection devices and signal routing; 2.04pF
3. 8 pF noise damping capacitor
4. C1 = 1.4 pF
5. S1 and S2 switch phases are non-overlapping and operate at the ADC clock frequency

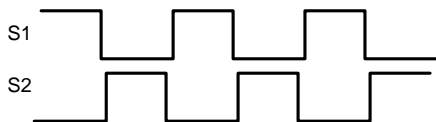

6. Equivalent input impedance, when the input is selected =
$$\frac{1}{(\text{ADC Clock Rate}) \times 1.4 \times 10^{-12}} + 100\text{ohm} + 125\text{ohm}$$

1. Parasitic capacitance due to package, pin-to-pin and pin-to-package base coupling; 1.8pF
2. Parasitic capacitance due to the chip bond pad, ESD protection devices and signal routing; 2.04pF
3. Equivalent resistance for the channel select mux; 100 ohms
4. Sampling capacitor at the sample and hold circuit. Capacitor C1 is normally disconnected from the input and is only connected to it at sampling time; 1.4pf
5. Equivalent input impedance, when the the input is selected =
$$\frac{1}{(\text{ADC Clock Rate}) \times 1.4 \times 10^{-12}}$$

Figure 10-17 Equivalent Circuit for A/D Loading

10.16 Power Consumption

See [Section 10.1](#) for a list of IDD requirements for the 56F8014. This section provides additional detail which can be used to optimize power consumption for a given application.

Power consumption is given by the following equation:

Total power = A: internal [static component]

+B: internal [state-dependent component]

Please see <http://www.freescale.com> for the most current mechanical drawing.

- +C: internal [dynamic component]
- +D: external [dynamic component]
- +E: external [static]

A, the internal [static component], is comprised of the DC bias currents for the oscillator, leakage currents, PLL, and voltage references. These sources operate independently of processor state or operating frequency.

B, the internal [state-dependent component], reflects the supply current required by certain on-chip resources only when those resources are in use. These include RAM, Flash memory and the ADCs.

C, the internal [dynamic component], is classic $C \cdot V^2 \cdot F$ CMOS power dissipation corresponding to the 56800E core and standard cell logic.

D, the external [dynamic component], reflects power dissipated on-chip as a result of capacitive loading on the external pins of the chip. This is also commonly described as $C \cdot V^2 \cdot F$, although simulations on two of the I/O cell types used on the 56800E reveal that the power-versus-load curve does have a non-zero Y-intercept.

Table 10-20 I/O Loading Coefficients at 10MHz

	Intercept	Slope
8mA drive	1.3	0.11mW / pF
4mA drive	1.15mW	0.11mW / pF

Power due to capacitive loading on output pins is (first order) a function of the capacitive load and frequency at which the outputs change. [Table 10-20](#) provides coefficients for calculating power dissipated in the I/O cells as a function of capacitive load. In these cases:

$$TotalPower = \Sigma((Intercept + Slope \cdot Cload) \cdot frequency / 10MHz)$$

where:

- Summation is performed over all output pins with capacitive loads
- TotalPower is expressed in mW
- Cload is expressed in pF

Because of the low duty cycle on most device pins, power dissipation due to capacitive loads was found to be fairly low when averaged over a period of time.

E, the external [static component], reflects the effects of placing resistive loads on the outputs of the device. Sum the total of all V^2/R or IV to arrive at the resistive load contribution to power. Assume $V = 0.5$ for the purposes of these rough calculations. For instance, if there is a total of eight PWM outputs driving 10mA into LEDs, then $P = 8 \cdot 0.5 \cdot 0.01 = 40mW$.

In previous discussions, power consumption due to parasitics associated with pure input pins is ignored, as it is assumed to be negligible.

Part 11 Packaging

11.1 56F8014 Package and Pin-Out Information

This section contains package and pin-out information for the 56F8014. This device comes in a 32-pin Low-profile Quad Flat Pack (LQFP). **Figure 11-1** shows the package outline for the 32-pin LQFP, **Figure 11-2** shows the mechanical parameters for this package, and **Table 11-1** lists the pin-out for the 32-pin LQFP.

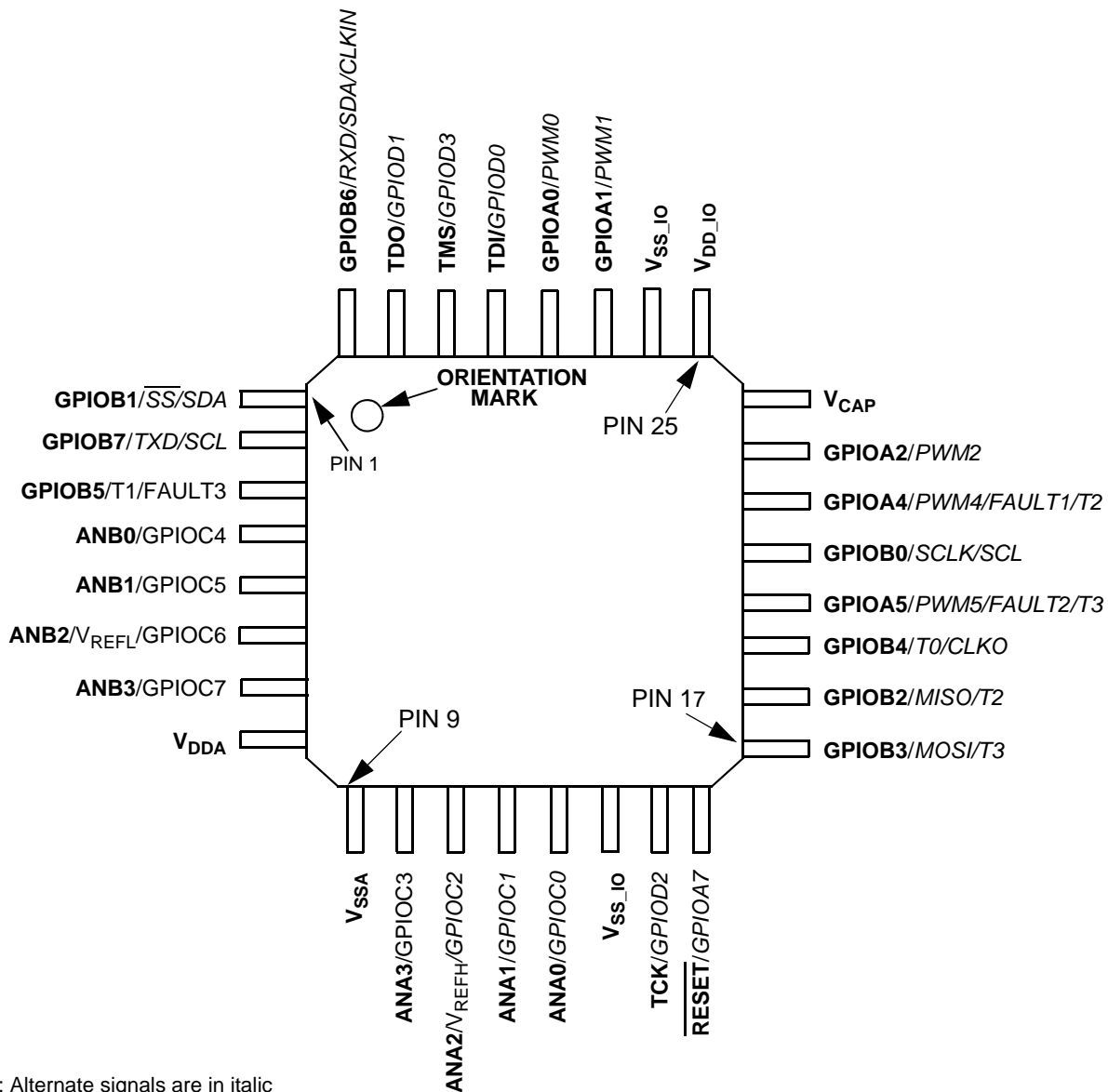

Note: Alternate signals are in italic

Figure 11-1 Top View, 56F8014 32-Pin LQFP Package

Table 11-1 56F8014 32-Pin LQFP Package Identification by Pin Number¹

Pin No.	Signal Name	Pin No.	Signal Name	Pin No.	Signal Name	Pin No.	Signal Name
1	GPIOB1 <i>SS,SDA</i>	9	V_{SSA}	17	GPIOB3 <i>MOSI,T3</i>	25	V_{DD_IO}
2	GPIOB7 <i>TXD,SCL</i>	10	ANA3 <i>GPIOC3</i>	18	GPIOB2 <i>MISO,T2</i>	26	V_{SS_IO}
3	GPIOB5 <i>T1,FAULT3</i>	11	ANA2 <i>V_{REFH},GPIOC2</i>	19	GPIOB4 <i>T0,CLKO</i>	27	GPIOA1 <i>PWM1</i>
4	ANB0 <i>GPIOC4</i>	12	ANA1 <i>GPIOC1</i>	20	GPIOA5 <i>PWM5,FAULT2,T3</i>	28	GPIOA0 <i>PWM0</i>
5	ANB1 <i>GPIOC5</i>	13	ANA0 <i>GPIOC0</i>	21	GPIOB0 <i>SCLK,CL</i>	29	TDI <i>GPIOD0</i>
6	ANB2 <i>V_{REFL},GPIOC6</i>	14	V_{SS_IO}	22	GPIOA4 <i>PWM4/FAULT1/T2</i>	30	TMS <i>GPIOD3</i>
7	ANB3 <i>GPIOC7</i>	15	TCK <i>GPIOD2</i>	23	GPIOA2 <i>PWM2</i>	31	TDO <i>GPIOD1</i>
8	V_{DDA}	16	RESET <i>GPIOA7</i>	24	V_{CAP}	32	GPIOB6 <i>RXD,SDA,CLKIN</i>

1. Alternate signals are in italic

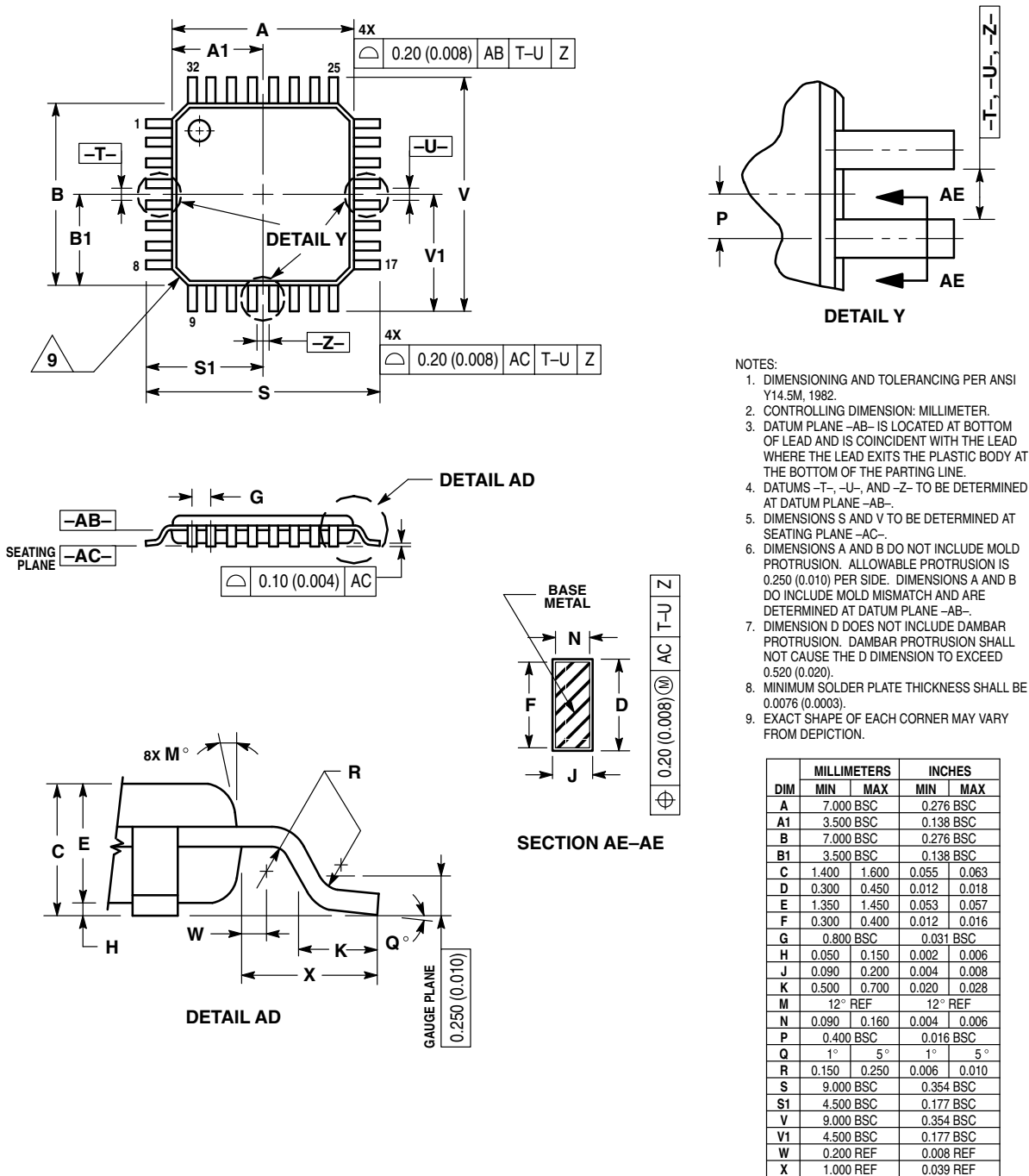

Figure 11-2 56F8014 32-Pin LQFP Mechanical Information

Part 12 Design Considerations

12.1 Thermal Design Considerations

An estimation of the chip junction temperature, T_J , can be obtained from the equation:

$$T_J = T_A + (R_{\theta JA} \times P_D)$$

where

- T_A = Ambient temperature for the package ($^{\circ}\text{C}$)
- $R_{\theta JA}$ = Junction-to-ambient thermal resistance ($^{\circ}\text{C}/\text{W}$)
- P_D = Power dissipation in the package (W)

The junction-to-ambient thermal resistance is an industry-standard value that provides a quick and easy estimation of thermal performance. Unfortunately, there are two values in common usage: the value determined on a single-layer board and the value obtained on a board with two planes. For packages such as the PBGA, these values can be different by a factor of two. Which value is closer to the application depends on the power dissipated by other components on the board. The value obtained on a single layer board is appropriate for the tightly packed printed circuit board. The value obtained on the board with the internal planes is usually appropriate if the board has low-power dissipation and the components are well separated.

When a heat sink is used, the thermal resistance is expressed as the sum of a junction-to-case thermal resistance and a case-to-ambient thermal resistance:

$$R_{\theta JA} = R_{\theta JC} + R_{\theta CA}$$

where

- $R_{\theta JA}$ = Package junction-to-ambient thermal resistance ($^{\circ}\text{C}/\text{W}$)
- $R_{\theta JC}$ = Package junction-to-case thermal resistance ($^{\circ}\text{C}/\text{W}$)
- $R_{\theta CA}$ = Package case-to-ambient thermal resistance ($^{\circ}\text{C}/\text{W}$)

$R_{\theta JC}$ is device related and cannot be influenced by the user. The user controls the thermal environment to change the case to ambient thermal resistance, $R_{\theta CA}$. For instance, the user can change the size of the heat sink, the air flow around the device, the interface material, the mounting arrangement on printed circuit board, or change the thermal dissipation on the printed circuit board surrounding the device.

To determine the junction temperature of the device in the application when heat sinks are not used, the Thermal Characterization Parameter (Ψ_{JT}) can be used to determine the junction temperature with a measurement of the temperature at the top center of the package case using the following equation:

$$T_J = T_T + (\Psi_{JT} \times P_D)$$

where

- T_T = Thermocouple temperature on top of package ($^{\circ}\text{C}$)

Ψ_{JT} = Thermal characterization parameter ($^{\circ}\text{C}/\text{W}$)

P_D = Power dissipation in package (W)

The thermal characterization parameter is measured per JESD51-2 specification using a 40-gauge type T thermocouple epoxied to the top center of the package case. The thermocouple should be positioned so that the thermocouple junction rests on the package. A small amount of epoxy is placed over the thermocouple junction and over about 1mm of wire extending from the junction. The thermocouple wire is placed flat against the package case to avoid measurement errors caused by cooling effects of the thermocouple wire.

When heat sink is used, the junction temperature is determined from a thermocouple inserted at the interface between the case of the package and the interface material. A clearance slot or hole is normally required in the heat sink. Minimizing the size of the clearance is important to minimize the change in thermal performance caused by removing part of the thermal interface to the heat sink. Because of the experimental difficulties with this technique, many engineers measure the heat sink temperature and then back-calculate the case temperature using a separate measurement of the thermal resistance of the interface. From this case temperature, the junction temperature is determined from the junction-to-case thermal resistance.

12.2 Electrical Design Considerations

CAUTION

This device contains protective circuitry to guard against damage due to high static voltage or electrical fields. However, normal precautions are advised to avoid application of any voltages higher than maximum-rated voltages to this high-impedance circuit. Reliability of operation is enhanced if unused inputs are tied to an appropriate voltage level.

Use the following list of considerations to assure correct operation of the 56F8014:

- Provide a low-impedance path from the board power supply to each V_{DD} pin on the 56F8014 and from the board ground to each V_{SS} (GND) pin
- The minimum bypass requirement is to place 0.01–0.1 μF capacitors positioned as close as possible to the package supply pins. The recommended bypass configuration is to place one bypass capacitor on each of the V_{DD}/V_{SS} pairs, including V_{DDA}/V_{SSA} . Ceramic and tantalum capacitors tend to provide better tolerances.
- Ensure that capacitor leads and associated printed circuit traces that connect to the chip V_{DD} and V_{SS} (GND) pins are as short as possible
- Bypass the V_{DD} and V_{SS} with approximately 100 μF , plus the number of 0.1 μF ceramic capacitors

- PCB trace lengths should be minimal for high-frequency signals
- Consider all device loads as well as parasitic capacitance due to PCB traces when calculating capacitance. This is especially critical in systems with higher capacitive loads that could create higher transient currents in the V_{DD} and V_{SS} circuits.
- Take special care to minimize noise levels on the V_{REF} , V_{DDA} and V_{SSA} pins
- Using separate power planes for V_{DD} and V_{DDA} and separate ground planes for V_{SS} and V_{SSA} is recommended. Connect the separate analog and digital power and ground planes as close as possible to power supply outputs. If both analog circuit and digital circuit are powered by the same power supply, it is advisable to connect a small inductor or ferrite bead in serial with both V_{DDA} and V_{SSA} traces.
- It is highly desirable to physically separate analog components from noisy digital components by ground planes. Do not place an analog trace in parallel with digital traces. It is also desirable to place an analog ground trace around an analog signal trace to isolate it from digital traces.
- Because the Flash memory is programmed through the JTAG/EOnCE port, SPI, SCI or I²C, the designer should provide an interface to this port if in-circuit Flash programming is desired.

Part 13 Ordering Information

Table 13-1 lists the pertinent information needed to place an order. Consult a Freescale Semiconductor sales office or authorized distributor to determine availability and to order parts.

Table 13-1 56F8014 Ordering Information

Part	Supply Voltage	Package Type	Pin Count	Frequency (MHz)	Abient Temperature Range	Order Number
MC56F8014	3.0–3.6 V	Low-Profile Quad Flat Pack (LQFP)	32	32	-40° to + 105° C	MC56F8014VFAE*
MC56F8014	3.0–3.6 V	Low-Profile Quad Flat Pack (LQFP)	32	32	-40° to +125 °C	MC56F8014MFAE*

*This package is RoHS compliant.

Part 14 Appendix

Register acronyms are revised from previous device data sheets to provide a cleaner register description. A cross reference to legacy and revised acronyms are provided in the following table.

Module	Register Name	Peripheral Reference Manual		Data Sheet		Processor Expert Acronym	Memory Address	
		New Acronym	Legacy Acronym	New Acronym	Legacy Acronym		Start	End
ADC	Control Register 1	CTRL1	ADCR1	ADC_CTRL1	ADC_ADCR1	ADC_ADCR1	0xF080	
	Control Register 2	CTRL2	ADCR2	ADC_CTRL2	ADC_ADCR2	ADC_ADCR2	0xF081	
	Zero Crossing Control Register	ZXCTRL	ADZCC	ADC_ZXCTRL	ADC_ADZCC	ADC_ADZCC	0xF082	
	Channel List Register 1	CLIST1	ADLST1	ADC_CLIST1	ADC_ADLST1	ADC_ADLST1	0xF083	
	Channel List Register 2	CLIST2	ADLST2	ADC_CLIST2	ADC_ADLST2	ADC_ADLST2	0xF084	
	Sample Disable Register	SDIS	ADSDIS	ADC_SDIS	ADC_ADSDIS	ADC_ADSDIS	0xF085	
	Status Register	STAT	ADSTAT	ADC_STAT	ADC_ADSTAT	ADC_ADSTAT	0xF086	
	Limit Status Register	LIMSTAT	ADLSTAT	ADC_LIMSTAT	ADC_ADLSTAT	ADC_ADLSTAT	0xF087	
	Zero Crossing Status Register	ZXSTAT	ADZCSTAT	ADC_ZXSTAT	ADC_ADZCSTAT	ADC_ADZCSTAT	0xF088	
	Result Registers 0-7	RSLT0-7	ADRSLT0-7	ADC_RSLT0-7	ADC_ADRSLT0-7	ADC_ADRSLT0-7	0xF089	0XF090
	Low Limit Registers 0-7	LOLIM0-7	ADLLMT0-7	ADC_LOLIM0-7	ADC_ADLLMT0-7	ADC_ADLLMT0-7	0XF091	0XF098
	High Limit Registers 0-7	HILIM0-7	ADHLMT0-7	ADC_HILIM0-7	ADC_ADHLMT0-7	ADC_ADHLMT0-7	0XF099	0XF0A0
	Offset Registers 0-7	OFFST0-7	ADOF0-7	ADC_OFFST0-7	ADC_ADOF0-7	ADC_ADOF0-7	0XF0A1	0XF0A8
	Power Control Register	PWR	ADPOWER	ADC_PWR	ADC_ADPOWER	ADC_ADPOWER	0XF0A9	
Voltage Reference Register	CAL	ADCAL	ADC_VREF	ADC_ADCAL	ADC_CAL	0XF0AA		
COP	Control Register	CTRL	COPCTL	COP_CTRL	COPCTL	COPCTL	0XF0E0	
	Time-Out Register	TOUT	COPTO	COP_TOUT	COPTO	COPTO	0XF0E1	
	Counter Register	CNTR	COPCTR	COP_CNTR	COPCTR	COPCTR	0XF0E2	



How to Reach Us:

Home Page:

www.freescale.com

E-mail:

support@freescale.com

USA/Europe or Locations Not Listed:

Freescale Semiconductor
Technical Information Center, CH370
1300 N. Alma School Road
Chandler, Arizona 85224
+1-800-521-6274 or +1-480-768-2130
support@freescale.com

Europe, Middle East, and Africa:

Freescale Halbleiter Deutschland GmbH
Technical Information Center
Schatzbogen 7
81829 Muenchen, Germany
+44 1296 380 456 (English)
+46 8 52200080 (English)
+49 89 92103 559 (German)
+33 1 69 35 48 48 (French)
support@freescale.com

Japan:

Freescale Semiconductor Japan Ltd.
Headquarters
ARCO Tower 15F
1-8-1, Shimo-Meguro, Meguro-ku,
Tokyo 153-0064, Japan
0120 191014 or +81 3 5437 9125
support.japan@freescale.com

Asia/Pacific:

Freescale Semiconductor Hong Kong Ltd.
Technical Information Center
2 Dai King Street
Tai Po Industrial Estate
Tai Po, N.T., Hong Kong
+800 2666 8080
support.asia@freescale.com

For Literature Requests Only:

Freescale Semiconductor Literature Distribution Center
P.O. Box 5405
Denver, Colorado 80217
1-800-441-2447 or 303-675-2140
Fax: 303-675-2150
LDCForFreescaleSemiconductor@hibbertgroup.com

RoHS-compliant and/or Pb-free versions of Freescale products have the functionality and electrical characteristics of their non-RoHS-compliant and/or non-Pb-free counterparts. For further information, see <http://www.freescale.com> or contact your Freescale sales representative.

For information on Freescale's Environmental Products program, go to <http://www.freescale.com/epp>.

Information in this document is provided solely to enable system and software implementers to use Freescale Semiconductor products. There are no express or implied copyright licenses granted hereunder to design or fabricate any integrated circuits or integrated circuits based on the information in this document.

Freescale Semiconductor reserves the right to make changes without further notice to any products herein. Freescale Semiconductor makes no warranty, representation or guarantee regarding the suitability of its products for any particular purpose, nor does Freescale Semiconductor assume any liability arising out of the application or use of any product or circuit, and specifically disclaims any and all liability, including without limitation consequential or incidental damages. "Typical" parameters that may be provided in Freescale Semiconductor data sheets and/or specifications can and do vary in different applications and actual performance may vary over time. All operating parameters, including "Typicals", must be validated for each customer application by customer's technical experts. Freescale Semiconductor does not convey any license under its patent rights nor the rights of others. Freescale Semiconductor products are not designed, intended, or authorized for use as components in systems intended for surgical implant into the body, or other applications intended to support or sustain life, or for any other application in which the failure of the Freescale Semiconductor product could create a situation where personal injury or death may occur. Should Buyer purchase or use Freescale Semiconductor products for any such unintended or unauthorized application, Buyer shall indemnify and hold Freescale Semiconductor and its officers, employees, subsidiaries, affiliates, and distributors harmless against all claims, costs, damages, and expenses, and reasonable attorney fees arising out of, directly or indirectly, any claim of personal injury or death associated with such unintended or unauthorized use, even if such claim alleges that Freescale Semiconductor was negligent regarding the design or manufacture of the part.



Freescale™ and the Freescale logo are trademarks of Freescale Semiconductor, Inc. All other product or service names are the property of their respective owners. This product incorporates SuperFlash® technology licensed from SST.

© Freescale Semiconductor, Inc. 2005. All rights reserved.

MC56F8014
Rev. 11
05/2008

Looking for pricing, stock, or lifecycle information?

Click below to explore more details on WIN SOURCE:

- ⊖ [View MC56F8014VFAE on WIN SOURCE](#)
- ⊖ [Freescale Semiconductor - NXP Information](#)

Optimize Your Supply Chain with WIN SOURCE Solutions

- ✓ Global Sourcing Solution
- ✓ Obsolete Management
- ✓ Cost Control Management
- ✓ Shortage Management
- ✓ Alternative Solution
- ✓ Excess Inventory Management