



**THE DATASHEET OF
MC74VHC1G66DFT2G**



MC74VHC1G66

SPST (NO) Normally Open Analog Switch

The MC74VHC1G66 is a single pole single throw (SPST) analog switch. It achieves high speed propagation delays and low ON resistances while maintaining low power dissipation. This bilateral switch controls analog and digital voltages that may vary across the full power-supply range (from V_{CC} to GND).

The MC74VHC1G66 is compatible in function to a single gate of the High Speed CMOS MC74VHC4066 and the metal-gate CMOS MC14066. The device has been designed so that the ON resistances (R_{ON}) are much lower and more linear over input voltage than R_{ON} of the metal-gate CMOS or High Speed CMOS analog switches.

The ON/OFF control inputs are compatible with standard CMOS outputs. The ON/OFF control input structure provides protection when voltages between 0 V and 5.5 V are applied, regardless of the supply voltage. This input structure helps prevent device destruction caused by supply voltage – input/output voltage mismatch, battery backup, hot insertion, etc.

Features

- High Speed: $t_{PD} = 20$ ns (Typ) at $V_{CC} = 5.0$ V
- Low Power Dissipation: $I_{CC} = 1.0$ μ A (Max) at $T_A = 25^\circ$ C
- Diode Protection Provided on Inputs and Outputs
- Improved Linearity and Lower ON Resistance over Input Voltage
- Chip Complexity: 11 FETs or 3 Equivalent Gates
- ON/OFF Control Input has OVT
- Chip Complexity: FETs = 11
- NLV Prefix for Automotive and Other Applications Requiring Unique Site and Control Change Requirements; AEC-Q100 Qualified and PPAP Capable
- These Devices are Pb-Free, Halogen Free/BFR Free and are RoHS Compliant



ON Semiconductor®

www.onsemi.com

MARKING DIAGRAMS



SC-88A
DF SUFFIX
CASE 419A

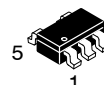
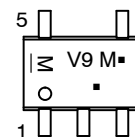

TSOP-5
DT SUFFIX
CASE 483

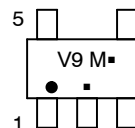

V9 = Device Code
M = Date Code*
▪ = Pb-Free Package

(Note: Microdot may be in either location)

*Date Code orientation and/or position may vary depending upon manufacturing location.

PIN ASSIGNMENT

1	IN/OUT X_A
2	OUT/IN Y_A
3	GND
4	ON/OFF CONTROL
5	V_{CC}

FUNCTION TABLE

On/Off Control Input	State of Analog Switch
L	Off
H	On

ORDERING INFORMATION

See detailed ordering and shipping information in the package dimensions section on page 7 of this data sheet.

MC74VHC1G66

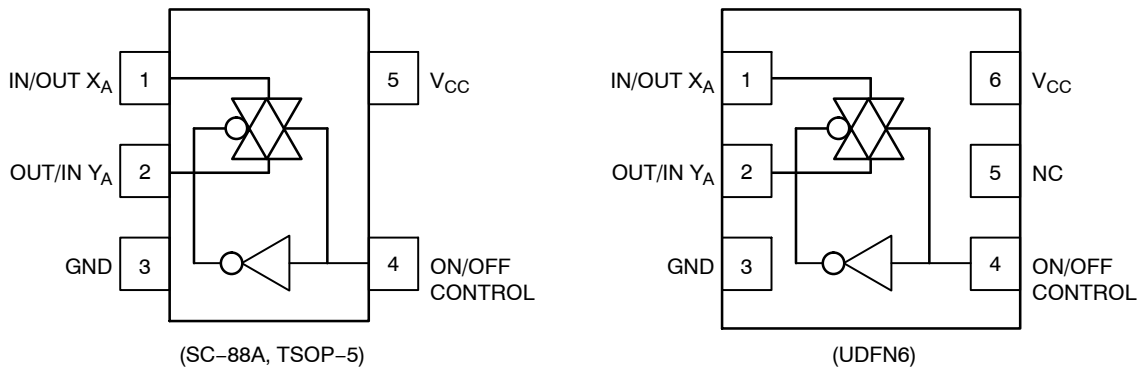

Figure 1. Pinout Diagrams

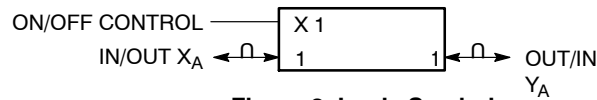

Figure 2. Logic Symbol

MAXIMUM RATINGS

Symbol	Characteristics	Value	Unit
V_{CC}	DC Supply Voltage	-0.5 to +7.0	V
V_{IN}	Digital Input Voltage	-0.5 to +7.0	V
V_{IS}	Analog Output Voltage	-0.5 to $V_{CC} + 0.5$	V
I_{IK}	Digital Input Diode Current	-20	mA
I_{CC}	DC Supply Current, V_{CC} and GND	+25	mA
T_{STG}	Storage Temperature Range	-65 to +150	°C
T_L	Lead Temperature, 1 mm from Case for 10 Seconds	260	°C
T_J	Junction Temperature Under Bias	+150	°C
θ_{JA}	Thermal Resistance	SC70-5 (Note 1) SOT23-5 350 230	°C/W
P_D	Power Dissipation in Still Air at 85°C	SC70-5 SOT23-5 150 200	mW
MSL	Moisture Sensitivity	Level 1	
F_R	Flammability Rating	Oxygen Index: 28 to 34 UL 94 V-0 @ 0.125 in	
V_{ESD}	ESD Withstand Voltage	Human Body Model (Note 2) Machine Model (Note 3) Charged Device Model (Note 4) > 2000 > 200 N/A	V
$I_{LATCHUP}$	Latchup Performance	Above V_{CC} and Below GND at 125°C (Note 5) ± 500	mA

Stresses exceeding those listed in the Maximum Ratings table may damage the device. If any of these limits are exceeded, device functionality should not be assumed, damage may occur and reliability may be affected.

1. Measured with minimum pad spacing on an FR4 board, using 10 mm-by-1 inch, 2-ounce copper trace with no air flow.
2. Tested to EIA/JESD22-A114-A.
3. Tested to EIA/JESD22-A115-A.
4. Tested to JESD22-C101-A.
5. Tested to EIA/JESD78.

MC74VHC1G66

RECOMMENDED OPERATING CONDITIONS

Symbol	Characteristics	Min	Max	Unit
V _{CC}	DC Supply Voltage	2.0	5.5	V
V _{IN}	DC Input Voltage	GND	5.5	V
V _{IS}	DC Output Voltage	GND	V _{CC}	V
T _A	Operating Temperature Range	-55	+125	°C
t _r , t _f	Input Rise and Fall Time ON/OFF Control Input	$V_{CC} = 3.3\text{ V} \pm 0.3\text{ V}$ 0	100	ns/V
		$V_{CC} = 5.0\text{ V} \pm 0.5\text{ V}$ 0	20	

Functional operation above the stresses listed in the Recommended Operating Ranges is not implied. Extended exposure to stresses beyond the Recommended Operating Ranges limits may affect device reliability.

Device Junction Temperature versus Time to 0.1% Bond Failures

Junction Temperature °C	Time, Hours	Time, Years
80	1,032,200	117.8
90	419,300	47.9
100	178,700	20.4
110	79,600	9.4
120	37,000	4.2
130	17,800	2.0
140	8,900	1.0

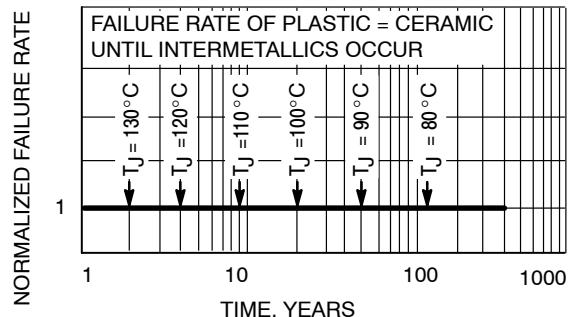

Figure 3. Failure Rate vs. Time Junction Temperature

DC ELECTRICAL CHARACTERISTICS

Symbol	Parameter	Test Conditions	V _{CC} (V)	T _A = 25°C		T _A ≤ 85°C		-55 ≤ T _A ≤ 125°C		Unit
				Min	Max	Min	Max	Min	Max	
V _{IH}	Minimum High-Level Input Voltage ON/OFF Control Input	R _{ON} = Per Spec	2.0	1.5		1.5		1.5		V
			3.0	2.1		2.1		2.1		
			4.5	3.15		3.15		3.15		
			5.5	3.85		3.85		3.85		
V _{IL}	Maximum Low-Level Input Voltage ON/OFF Control Input	R _{ON} = Per Spec	2.0		0.5		0.5		0.5	V
			3.0		0.9		0.9		0.9	
			4.5		1.35		1.35		1.35	
			5.5		1.65		1.65		1.65	
I _{IN}	Maximum Input Leakage Current ON/OFF Control Input	V _{IN} = V _{CC} or GND	0 to 5.5		±0.1		±1.0		±1.0	μA
I _{CC}	Maximum Quiescent Supply Current	V _{IN} = V _{CC} or GND V _{IO} = 0 V	5.5		1.0		20		40	μA
R _{ON}	Maximum "ON" Resistance	V _{IN} = V _{IH} V _{IS} = V _{CC} or GND I _{IS} ≤ 5 mA (Figure 4)	3.0		60		70		100	Ω
			4.5		45		50		60	
			5.5		40		45		55	
I _{OFF}	Maximum Off-Channel Leakage Current	V _{IN} = V _{IL} V _{IS} = V _{CC} or GND Switch Off (Figure 5)	5.5		0.1		0.5		1.0	μA

Product parametric performance is indicated in the Electrical Characteristics for the listed test conditions, unless otherwise noted. Product performance may not be indicated by the Electrical Characteristics if operated under different conditions.

MC74VHC1G66

AC ELECTRICAL CHARACTERISTICS $C_{load} = 50 \text{ pF}$, Input $t_r/t_f = 3.0 \text{ ns}$

Symbol	Parameter	Test Conditions	V_{CC} (V)	$T_A = 25^\circ\text{C}$			$T_A \leq 85^\circ\text{C}$		$-55 \leq T_A \leq 125^\circ\text{C}$		Unit
				Min	Typ	Max	Min	Max	Min	Max	
t_{PLH} , t_{PHL}	Maximum Propagation Delay, Input X to Y	$Y_A = \text{Open}$ (Figure 14)	2.0		1	5		6		7	ns
			3.0		0.6	2		3		4	
			4.5		0.6	1		1		2	
			5.5		0.6	1		1		1	
t_{PLZ} , t_{PHZ}	Maximum Propagation Delay, ON/OFF Control to Analog Output	$R_L = 1000 \Omega$ (Figure 15)	2.0		32	40		45		50	ns
			3.0		28	35		40		45	
			4.5		24	30		35		40	
			5.5		20	25		30		35	
t_{PZL} , t_{PZH}	Maximum Propagation Delay, ON/OFF Control to Analog Output	$R_L = 1000 \Omega$ (Figure 15)	2.0		32	40		45		50	ns
			3.0		28	35		40		45	
			4.5		24	30		35		40	
			5.5		20	25		30		35	
C_{IN}	Maximum Input Capacitance	ON/OFF Control Input	0.0		3	10		10		10	pF
		Control Input = GND Analog I/O Feedthrough	5.0		4	10		10		10	
				Typical @ 25°C, $V_{CC} = 5.0 \text{ V}$							
C_{PD}	Power Dissipation Capacitance (Note 6)			18						pF	

6. C_{PD} is defined as the value of the internal equivalent capacitance which is calculated from the operating current consumption without load. Average operating current can be obtained by the equation: $I_{CC(OPR)} = C_{PD} \cdot V_{CC} \cdot f_{in} + I_{CC}$. C_{PD} is used to determine the no-load dynamic power consumption; $P_D = C_{PD} \cdot V_{CC}^2 \cdot f_{in} + I_{CC} \cdot V_{CC}$.

ADDITIONAL APPLICATION CHARACTERISTICS (Voltages Referenced to GND Unless Noted)

Symbol	Parameter	Test Conditions	V_{CC}	Limit 25°C	Unit
BW	Maximum On-Channel Bandwidth or Minimum Frequency Response (Figure 10)	$f_{in} = 1 \text{ MHz}$ Sine Wave Adjust f_{in} voltage to obtain 0 dBm at V_{OS} Increase $f_{in} = \text{frequency}$ until dB meter reads -3 dB $R_L = 50 \Omega$	3.0 4.5 5.5	150 175 180	MHz
ISO_{off}	Off-Channel Feedthrough Isolation (Figure 11)	$f_{in} = \text{Sine Wave}$ Adjust f_{in} voltage to obtain 0 dBm at V_{IS} $f_{in} = 10 \text{ kHz}$, $R_L = 600 \Omega$	3.0 4.5 5.5	-80 -80 -80	dB
$NOISE_{feed}$	Feedthrough Noise Control to Switch (Figure 12)	$V_{in} \leq 1 \text{ MHz}$ Square Wave ($t_r = t_f = 2 \text{ ns}$) $R_L = 600 \Omega$	3.0 4.5 5.5	45 60 130	mV _{PP}
THD	Total Harmonic Distortion (Figure 13)	$f_{in} = 1 \text{ kHz}$, $R_L = 10 \text{ k}\Omega$ $THD = THD_{Measured} - THD_{Source}$ $V_{IS} = 3.0 \text{ V}_{PP}$ sine wave $V_{IS} = 5.0 \text{ V}_{PP}$ sine wave	3.3 5.5	0.30 0.15	%

MC74VHC1G66

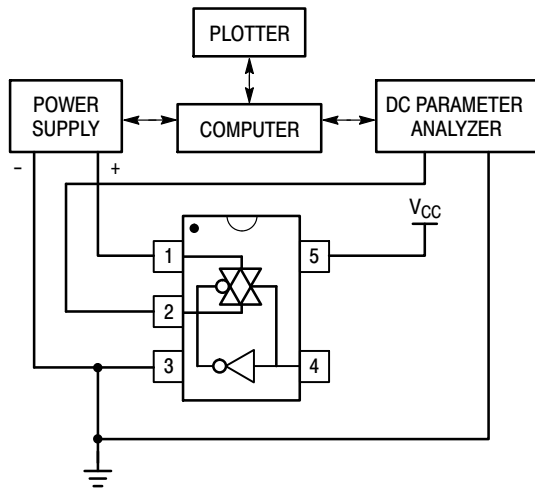

Figure 4. On Resistance Test Set-Up

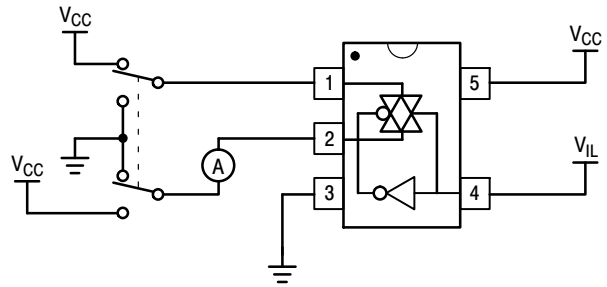

Figure 5. Maximum Off-Channel Leakage Current Test Set-Up

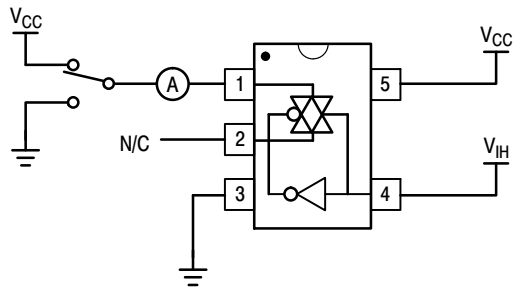

Figure 6. Maximum On-Channel Leakage Current Test Set-Up

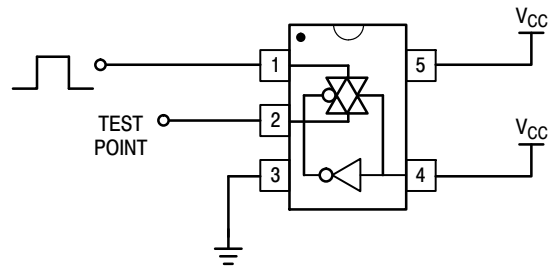

Figure 7. Propagation Delay Test Set-Up

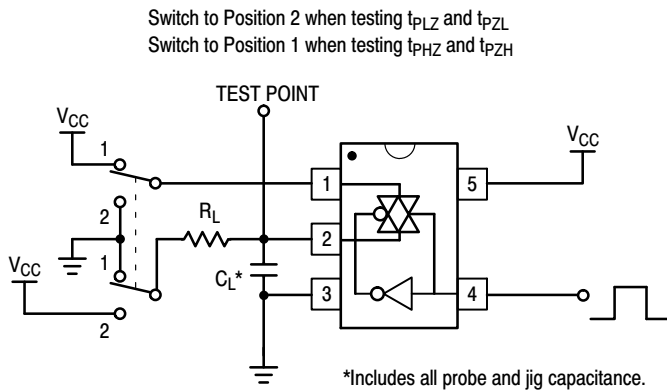

Figure 8. Propagation Delay Output Enable/Disable Test Set-Up

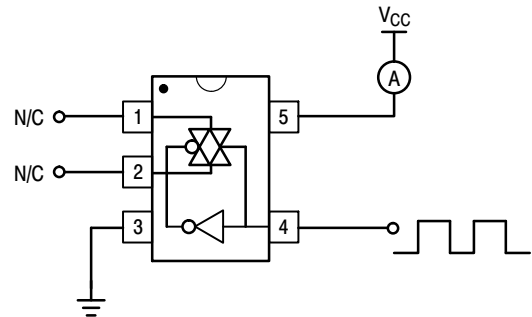

Figure 9. Power Dissipation Capacitance Test Set-Up

MC74VHC1G66

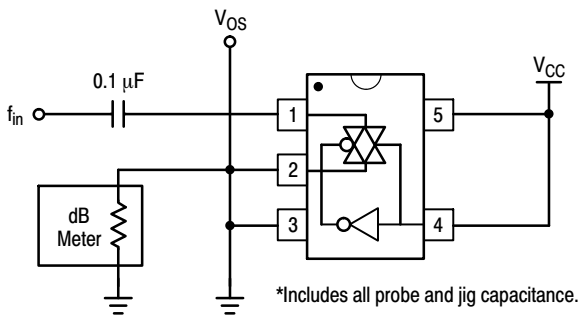

Figure 10. Maximum On-Channel Bandwidth Test Set-Up

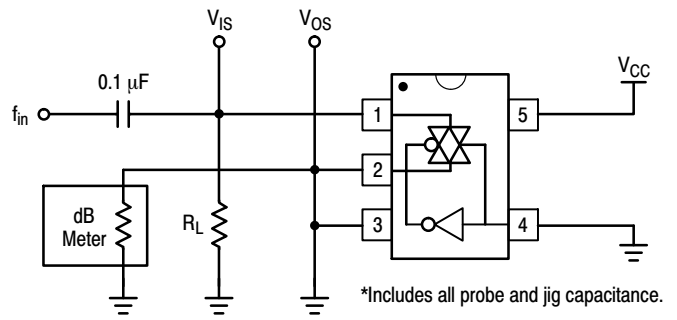

Figure 11. Off-Channel Feedthrough Isolation Test Set-Up

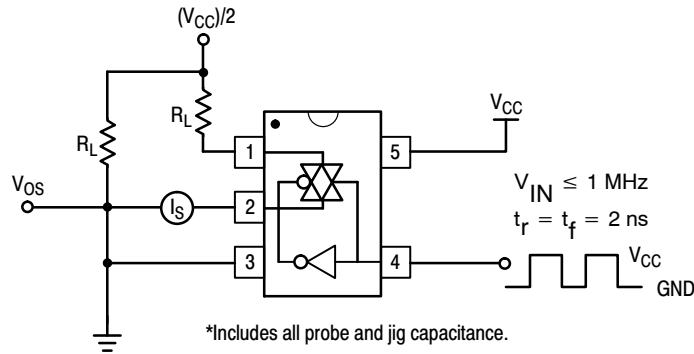

Figure 12. Feedthrough Noise, ON/OFF Control to Analog Out, Test Set-Up

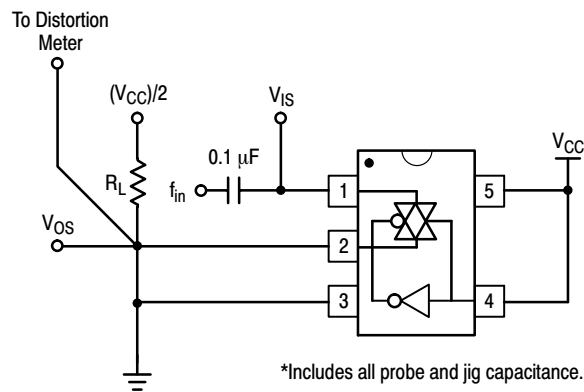

Figure 13. Total Harmonic Distortion Test Set-Up

MC74VHC1G66

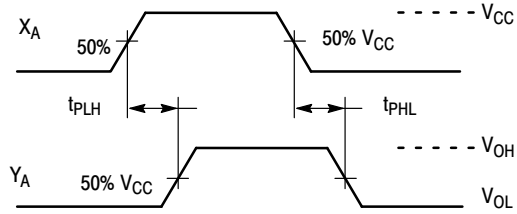

Figure 14. Propagation Delay, Analog In to Analog Out Waveforms

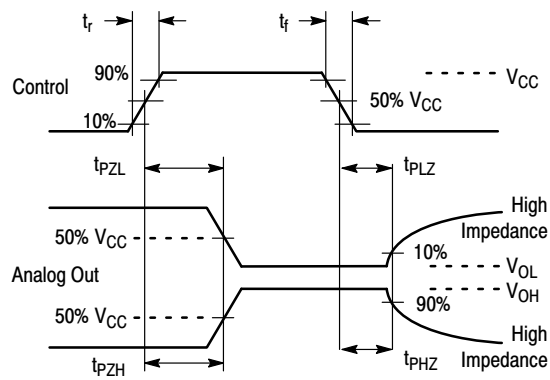

Figure 15. Propagation Delay, ON/OFF Control

ORDERING INFORMATION

Device	Package	Shipping [†]
MC74VHC1G66DFT1G	SC-88A (Pb-Free)	3000 / Tape & Reel
NLVVHC1G66DFT1G*		
MC74VHC1G66DFT2G		
NLVVHC1G66DFT2G*		
MC74VHC1G66DTT1G	TSOP-5 (Pb-Free)	3000 / Tape & Reel
NLVVHC1G66DTT1G*		

[†]For information on tape and reel specifications, including part orientation and tape sizes, please refer to our Tape and Reel Packaging Specifications Brochure, BRD8011/D.

*NLV Prefix for Automotive and Other Applications Requiring Unique Site and Control Change Requirements; AEC-Q100 Qualified and PPAP Capable.

MC74VHC1G66

PACKAGE DIMENSIONS

SC-88A (SC-70-5/SOT-353)
CASE 419A-02
ISSUE L

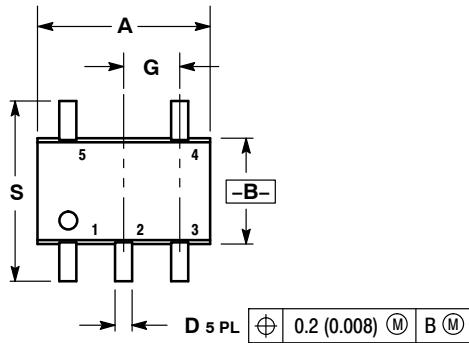

NOTES:

1. DIMENSIONING AND TOLERANCING PER ANSI Y14.5M, 1982.
2. CONTROLLING DIMENSION: INCH.
3. 419A-01 OBSOLETE. NEW STANDARD 419A-02.
4. DIMENSIONS A AND B DO NOT INCLUDE MOLD FLASH, PROTRUSIONS, OR GATE BURRS.

DIM	INCHES		MILLIMETERS	
	MIN	MAX	MIN	MAX
A	0.071	0.087	1.80	2.20
B	0.045	0.053	1.15	1.35
C	0.031	0.043	0.80	1.10
D	0.004	0.012	0.10	0.30
G	0.026 BSC		0.65 BSC	
H	---	0.004	---	0.10
J	0.004	0.010	0.10	0.25
K	0.004	0.012	0.10	0.30
N	0.008 REF		0.20 REF	
S	0.079	0.087	2.00	2.20

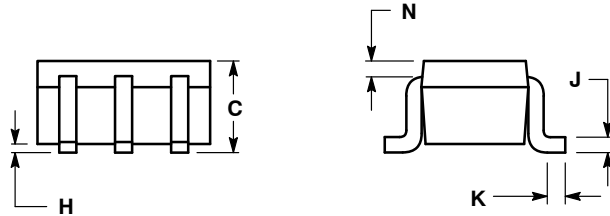

SOLDER FOOTPRINT

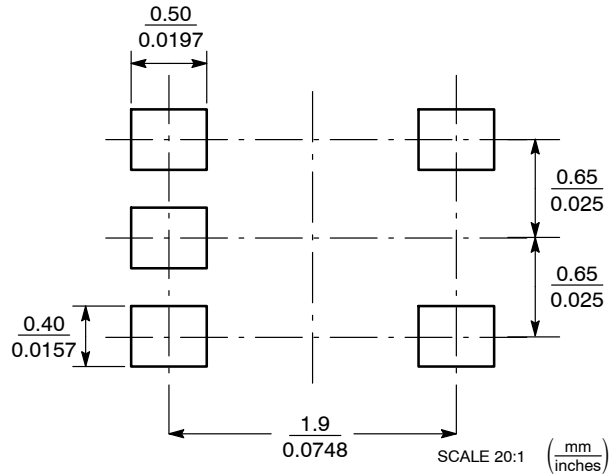

MC74VHC1G66

PACKAGE DIMENSIONS

TSOP-5 CASE 483-02 ISSUE M

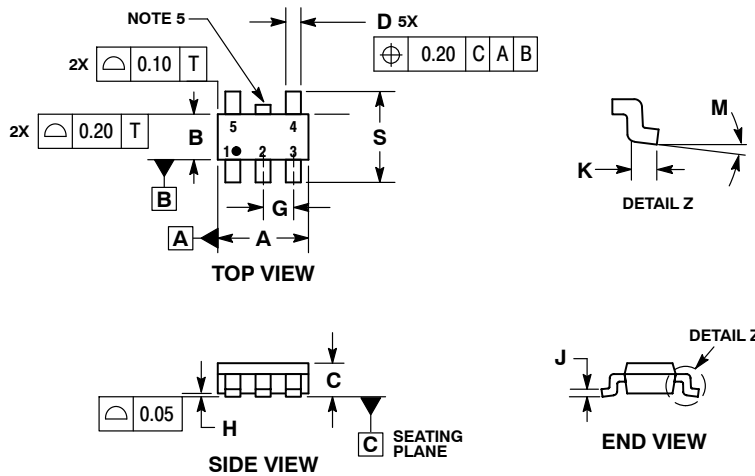

NOTES:

1. DIMENSIONING AND TOLERANCING PER ASME Y14.5M, 1994.
2. CONTROLLING DIMENSION: MILLIMETERS.
3. MAXIMUM LEAD THICKNESS INCLUDES LEAD FINISH THICKNESS. MINIMUM LEAD THICKNESS IS THE MINIMUM THICKNESS OF BASE MATERIAL.
4. DIMENSIONS A AND B DO NOT INCLUDE MOLD FLASH, PROTRUSIONS, OR GATE BURRS. MOLD FLASH, PROTRUSIONS, OR GATE BURRS SHALL NOT EXCEED 0.15 PER SIDE. DIMENSION A.
5. OPTIONAL CONSTRUCTION: AN ADDITIONAL TRIMMED LEAD IS ALLOWED IN THIS LOCATION. TRIMMED LEAD NOT TO EXTEND MORE THAN 0.2 FROM BODY.

DIM	MILLIMETERS	
	MIN	MAX
A	2.85	3.15
B	1.35	1.65
C	0.90	1.10
D	0.25	0.50
G	0.95 BSC	
H	0.01	0.10
J	0.10	0.26
K	0.20	0.60
M	0°	10°
S	2.50	3.00

SOLDERING FOOTPRINT*

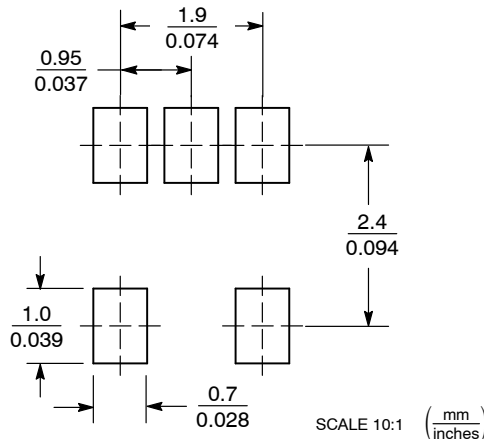

*For additional information on our Pb-Free strategy and soldering details, please download the ON Semiconductor Soldering and Mounting Techniques Reference Manual, SOLDERRM/D.

ON Semiconductor and are trademarks of Semiconductor Components Industries, LLC dba ON Semiconductor or its subsidiaries in the United States and/or other countries. ON Semiconductor owns the rights to a number of patents, trademarks, copyrights, trade secrets, and other intellectual property. A listing of ON Semiconductor's product/patent coverage may be accessed at www.onsemi.com/site/pdf/Patent-Marking.pdf. ON Semiconductor reserves the right to make changes without further notice to any products herein. ON Semiconductor makes no warranty, representation or guarantee regarding the suitability of its products for any particular purpose, nor does ON Semiconductor assume any liability arising out of the application or use of any product or circuit, and specifically disclaims any and all liability, including without limitation special, consequential or incidental damages. Buyer is responsible for its products and applications using ON Semiconductor products, including compliance with all laws, regulations and safety requirements or standards, regardless of any support or applications information provided by ON Semiconductor. "Typical" parameters which may be provided in ON Semiconductor data sheets and/or specifications can and do vary in different applications and actual performance may vary over time. All operating parameters, including "Typicals" must be validated for each customer application by customer's technical experts. ON Semiconductor does not convey any license under its patent rights nor the rights of others. ON Semiconductor products are not designed, intended, or authorized for use as a critical component in life support systems or any FDA Class 3 medical devices or medical devices with a same or similar classification in a foreign jurisdiction or any devices intended for implantation in the human body. Should Buyer purchase or use ON Semiconductor products for any such unintended or unauthorized application, Buyer shall indemnify and hold ON Semiconductor and its officers, employees, subsidiaries, affiliates, and distributors harmless against all claims, costs, damages, and expenses, and reasonable attorney fees arising out of, directly or indirectly, any claim of personal injury or death associated with such unintended or unauthorized use, even if such claim alleges that ON Semiconductor was negligent regarding the design or manufacture of the part. ON Semiconductor is an Equal Opportunity/Affirmative Action Employer. This literature is subject to all applicable copyright laws and is not for resale in any manner.

PUBLICATION ORDERING INFORMATION

LITERATURE FULFILLMENT:

Literature Distribution Center for ON Semiconductor
19521 E. 32nd Pkwy, Aurora, Colorado 80011 USA
Phone: 303-675-2175 or 800-344-3860 Toll Free USA/Canada
Fax: 303-675-2176 or 800-344-3867 Toll Free USA/Canada
Email: orderlit@onsemi.com

N. American Technical Support: 800-282-9855 Toll Free
USA/Canada
Europe, Middle East and Africa Technical Support:
Phone: 421 33 790 2910

ON Semiconductor Website: www.onsemi.com

Order Literature: <http://www.onsemi.com/orderlit>

For additional information, please contact your local Sales Representative

Looking for pricing, stock, or lifecycle information?

Click below to explore more details on WIN SOURCE:

 [View MC74VHC1G66DFT2G on WIN SOURCE](#)

 [ON Semiconductor](#) Information

Optimize Your Supply Chain with WIN SOURCE Solutions

-  Global Sourcing Solution
-  Obsolete Management
-  Cost Control Management
-  Shortage Management
-  Alternative Solution
-  Excess Inventory Management