



THE DATASHEET OF MCT62



8-pin Dual-Channel Phototransistor Optocouplers

MCT6, MCT61, MCT62

Description

The general purpose optocouplers, MCT6, MCT61, and MCT62, have two isolated channels in a standard plastic 8-pin dual-in-line (DIP) package for density applications. Each channel consists of a gallium arsenide infrared emitting diode driving a NPN silicon planar phototransistor. For four channel applications, two packages fit into a standard 16-pin DIP socket.

Features

- Two Isolated Channels Per Package
- Safety and Regulatory Approvals:
 - UL1577, 5,000 VAC_{RMS} for 1 Minute
 - DIN-EN/IEC60747-5-5, 890 V Peak Working Insulation Voltage
- These are Pb-Free Devices

Applications

- AC Line/Digital Logic – Isolate High Voltage Transients
- Digital Logic/Digital Logic – Eliminate Spurious Grounds
- Digital Logic/AC Triac Control – Isolate High Voltage Transients
- Twisted Pair Line Receiver – Eliminate Ground Loop Feedthrough
- Telephone/Telegraph Line Receiver – Isolate High Voltage Transients
- High Frequency Power Supply Feedback Control– Maintain Floating Grounds and Transients
- Relay Contact Monitor – Isolate Floating Grounds and Transients
- Power Supply Monitor – Isolate Transients

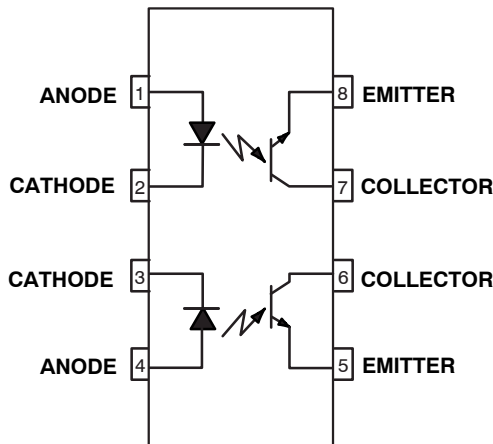
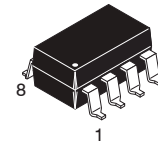
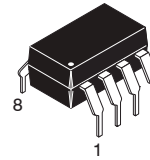

Figure 1. Schematic



PDIP8 GW
CASE 709AF



PDIP8 9.68x6.5,
2.54P
CASE 646CJ

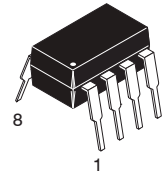

PDIP8 9.655x6.6,
2.54P
CASE 646CQ

MARKING DIAGRAM

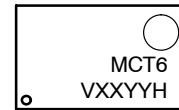

MCT6 = Specific Device Code
 V = DIN EN/IEC 60747-5-5 option
 (only appears on component ordered with this option)
 XX = Two Digit Year Code, e.g., "16"
 YY = Digit Work Week Ranging from "01" to "53"
 H = Assembly Package Code

ORDERING INFORMATION

See detailed ordering and shipping information in the package dimensions section on page 6 of this data sheet.

MCT6, MCT61, MCT62

Safety and Insulation Ratings

As per DIN EN/IEC 60747-5-5, this optocoupler is suitable for “safe electrical insulation” only within the safety limit data. Compliance with the safety ratings shall be ensured by means of protective circuits.

Parameter		Characteristics
Installation Classifications per DIN VDE 0110/1.89 Table 1, For Rated Mains Voltage	< 150 V _{RMS}	I-IV
	< 300 V _{RMS}	I-III
Climatic Classification		55/100/21
Pollution Degree (DIN VDE 0110/1.89)		2
Comparative Tracking Index		175

Symbol	Parameter	Value	Unit
V _{PR}	Input-to-Output Test Voltage, Method A, V _{IORM} × 1.6 = V _{PR} , Type and Sample Test with t _m = 10 s, Partial Discharge < 5 pC	1424	V _{peak}
	Input-to-Output Test Voltage, Method B, V _{IORM} × 1.875 = V _{PR} , 100% Production Test with t _m = 1 s, Partial Discharge < 5 pC	1668	V _{peak}
V _{IORM}	Maximum Working Insulation Voltage	890	V _{peak}
V _{IOTM}	Highest Allowable Over-Voltage	8000	V _{peak}
	External Creepage	≥7	mm
	External Clearance	≥7	mm
DTI	Distance Through Insulation (Insulation Thickness)	≥0.4	mm
T _S	Case Temperature (Note 1)	175	°C
I _{S,INPUT}	Input Current (Note 1)	60	mA
P _{S,OUTPUT}	Output Power (Note 1)	150	mW
R _{IO}	Insulation Resistance at T _S , V _{IO} = 500 V (Note 1)	>10 ⁹	Ω

1. Safety limit values – maximum values allowed in the event of a failure.

ABSOLUTE MAXIMUM RATINGS (T_A = 25°C unless otherwise noted)

Symbol	Rating	Value	Unit
TOTAL DEVICE			
T _{STG}	Storage Temperature	-55 to +150	°C
T _{OPR}	Operating Temperature	-55 to +100	°C
T _J	Junction Temperature	-55 to +125	°C
T _{SOL}	Lead Solder Temperature	260 for 10 seconds	°C
P _D	Total Device Power Dissipation @ T _A = 25°C	400	mW
	Derate Above 25°C	5.33	mW/°C

EMITTER (Each channel)

I _F	DC / Average Forward Input Current	60	mA
I _{F(pk)}	Forward Current – Peak (PW = 1 μs, 300 pps)	3	A
V _R	Reverse Input Voltage	3	V
P _{D(EMITTER)}	Total Power Dissipation @ T _A = 25°C	100	mW
	Derate Above 25°C	1.3	mW/°C

DETECTOR

I _C	Continuous Collector Current	30	mA
P _{D(DETECTOR)}	Total Power Dissipation @ T _A = 25°C	150	mW
	Derate Above 25°C	2.0	mW/°C

Stresses exceeding those listed in the Maximum Ratings table may damage the device. If any of these limits are exceeded, device functionality should not be assumed, damage may occur and reliability may be affected.

MCT6, MCT61, MCT62

ELECTRICAL CHARACTERISTICS ($T_A = 25^\circ\text{C}$ unless otherwise noted)

Individual Component Characteristics

Symbol	Parameter	Test Conditions	Min	Typ	Max	Unit
EMITTER						
V_F	Input Forward Voltage	$I_F = 20\text{ mA}$	–	1.2	1.5	V
V_R	Reverse Voltage	$I_R = 10\ \mu\text{A}$	3	25	–	V
I_R	Reverse Leakage Current	$V_R = 5\text{ V}$	–	0.001	10	μA
C_J	Junction Capacitance	$V_F = 0\text{ V}, f = 1\text{ MHz}$	–	50	–	pF

DETECTOR

BV_{CEO}	Collector-to-Emitter Breakdown Voltage	$I_C = 1.0\text{ mA}, I_F = 0$	30	85	–	V
BV_{ECO}	Emitter-to-Collector Breakdown Voltage	$I_E = 100\ \mu\text{A}, I_F = 0$	6	13	–	V
I_{CEO}	Collector-to-Emitter Dark Current	$V_{CE} = 10\text{ V}, I_F = 0$	–	5	100	nA
C_{CE}	Capacitance	$V_{CE} = 0\text{ V}, f = 1\text{ MHz}$	–	8	–	pF

Product parametric performance is indicated in the Electrical Characteristics for the listed test conditions, unless otherwise noted. Product performance may not be indicated by the Electrical Characteristics if operated under different conditions.

Transfer Characteristics

Symbol	Parameter	Device	Test Conditions	Min	Typ	Max	Unit
--------	-----------	--------	-----------------	-----	-----	-----	------

DC CHARACTERISTICS

C_{TR}	Current Transfer Ratio, Collector-to-Emitter	MCT6	$I_F = 10\text{ mA}, V_{CE} = 10\text{ V}$	20	–	–	%
		MCT61	$I_F = 5\text{ mA}, V_{CE} = 5\text{ V}$	50	–	–	
		MCT62		100	–	–	
$V_{CE(SAT)}$	Saturation Voltage, Collector-to-Emitter	ALL	$I_F = 16\text{ mA}, I_C = 2\text{ mA}$	–	0.15	0.4	V

AC CHARACTERISTICS

Symbol	Parameter	Test Conditions	Min	Typ	Max	Unit
--------	-----------	-----------------	-----	-----	-----	------

Non-Saturated

t_{on}	Turn-On Time	$R_L = 100\ \Omega, I_C = 2\text{ mA}, V_{CC} = 10\text{ V}$	–	3.0	–	μs
t_{off}	Turn-Off Time		–	3.0	–	μs
t_r	Rise Time		–	2.4	–	μs
t_f	Fall Time		–	2.4	–	μs

Saturated

t_{on}	Turn-On Time	$I_F = 16\text{ mA}, R_L = 1.9\text{ k}\Omega, V_{CE} = 5\text{ V}$	–	2.4	–	μs
t_{off}	Turn-Off Time		–	25.0	–	μs

Isolation Characteristics

Symbol	Parameter	Test Conditions	Min	Typ	Max	Unit
V_{ISO}	Input-Output Isolation Voltage	$I_{I-O} \leq 10\ \mu\text{A}, t = 1\text{ Minute}$	5,000	–	–	$V_{AC_{RMS}}$
C_{ISO}	Isolation Capacitance	$f = 1\text{ MHz}$	–	0.5	–	pF
R_{ISO}	Isolation Resistance	$V_{I-O} = 500\text{ VDC}$	10^{11}	–	–	Ω

MCT6, MCT61, MCT62

TYPICAL PERFORMANCE CURVES

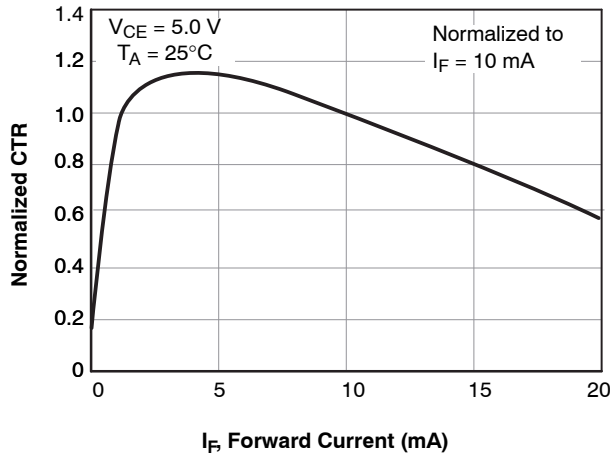

Figure 2. Normalized CTR vs. Forward Current

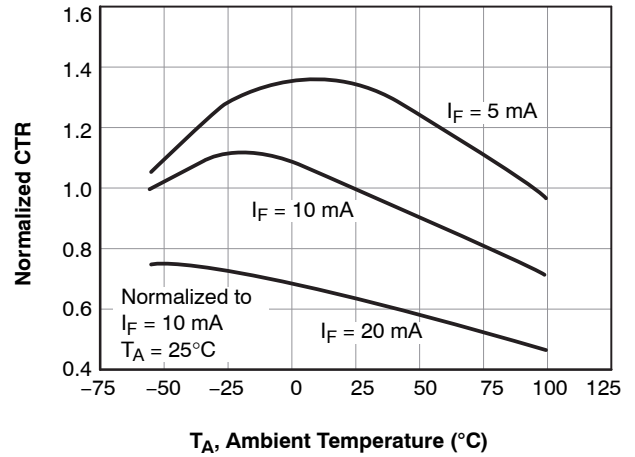

Figure 3. Normalized CTR vs. Ambient Temperature

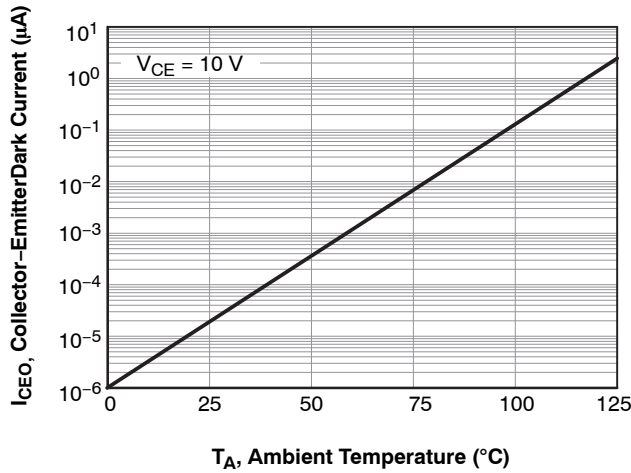

Figure 4. Dark Current vs. Ambient Temperature

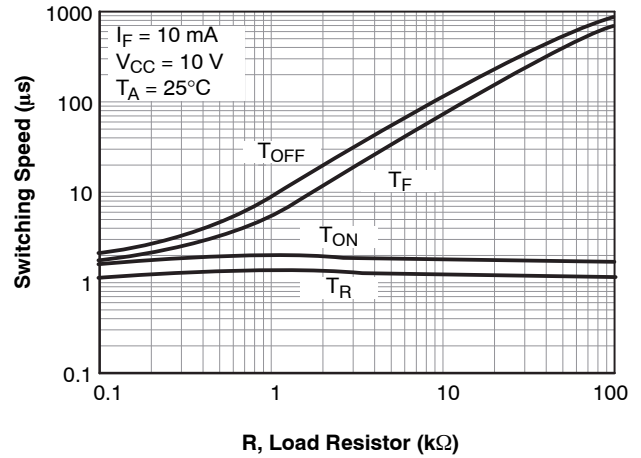

Figure 5. Switching Speed vs. Load Resistor

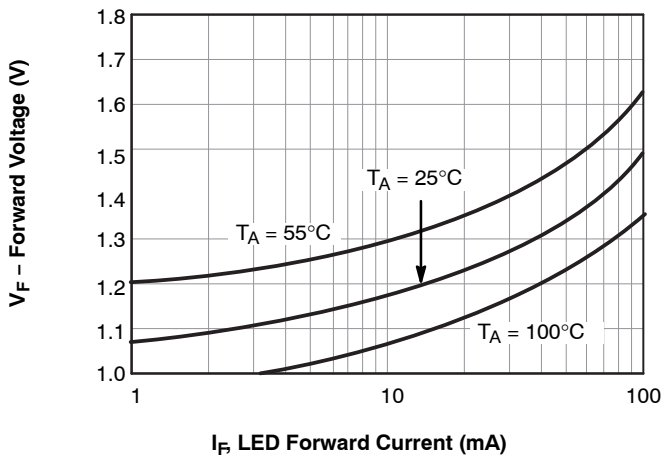

Figure 6. LED Forward Voltage vs. Forward Current

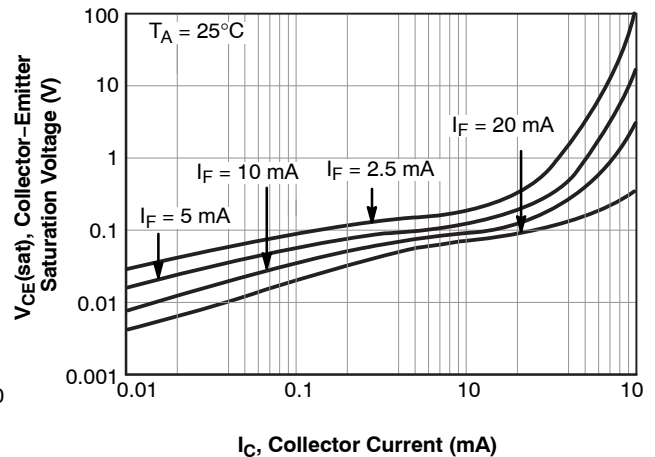

Figure 7. Collector-Emitter Saturation Voltage vs. Collector Current

MCT6, MCT61, MCT62

SWITCHING TIME TEST CIRCUIT AND WAVEFORMS

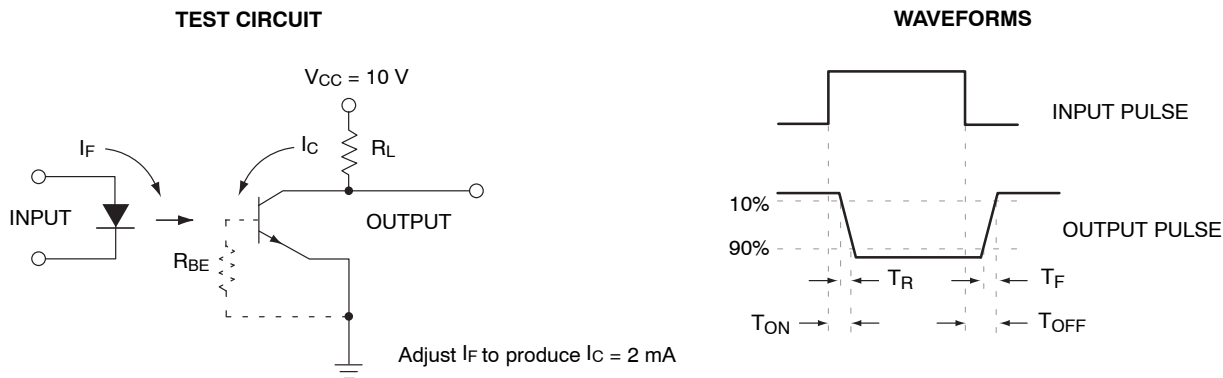

Figure 8. Switching Time Test Circuit and Waveforms

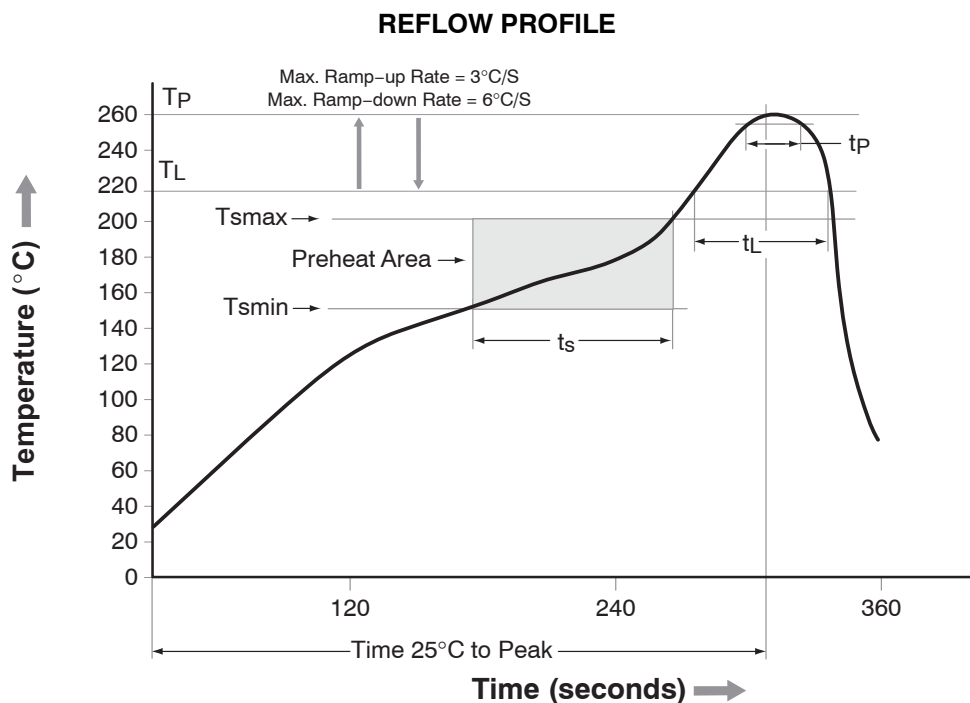

Figure 9. Reflow Profile

Profile Feature	Pb-Free Assembly Profile
Temperature Minimum (T_{smin})	150°C
Temperature Maximum (T_{smax})	200°C
Time (t_s) from (T_{smin} to T_{smax})	60 – 120 seconds
Ramp-up Rate (t_L to t_p)	3°C/second maximum
Liquidous Temperature (T_L)	217°C
Time (t_L) Maintained Above (T_L)	60 – 150 seconds
Peak Body Package Temperature	$260^\circ\text{C} +0^\circ\text{C} / -5^\circ\text{C}$
Time (t_p) within 5°C of 260°C	30 seconds
Ramp-down Rate (T_P to T_L)	6°C/second maximum
Time 25°C to Peak Temperature	8 minutes maximum

MCT6, MCT61, MCT62

ORDERING INFORMATION

Part Number	Package	Packing Method [†]
MCT6	DIP 8-Pin	50 Units / Tube
MCT6S	SMT 8-Pin (Lead Bend)	50 Units / Tube
MCT6SD	SMT 8-Pin	1,000 Units / Tape & Reel
MCT6300	DIN EN/IEC 60747-5-5 Option	50 Units / Tube
MCT63S	SMT 8-Pin (Lead Bend); DIN EN/IEC 60747-5-5 Option	50 Units / Tube
MCT63SD	SMT 8-Pin; DIN EN/IEC 60747-5-5 Option	1,000 Units / Tape & Reel
MCT6300W	0.4" Lead Spacing; DIN EN/IEC 60747-5-5 Option	50 Units / Tube

[†]For information on tape and reel specifications, including part orientation and tape sizes, please refer to our Tape and Reel Packaging Specifications Brochure, [BRD8011/D](#).

NOTE: The product orderable part number system listed in this table also applies to the MCT61 and MCT62.

MECHANICAL CASE OUTLINE

PACKAGE DIMENSIONS

ON Semiconductor®



PDIP8 9.68x6.5, 2.54P
CASE 646CJ
ISSUE 0

DATE 31 JUL 2016

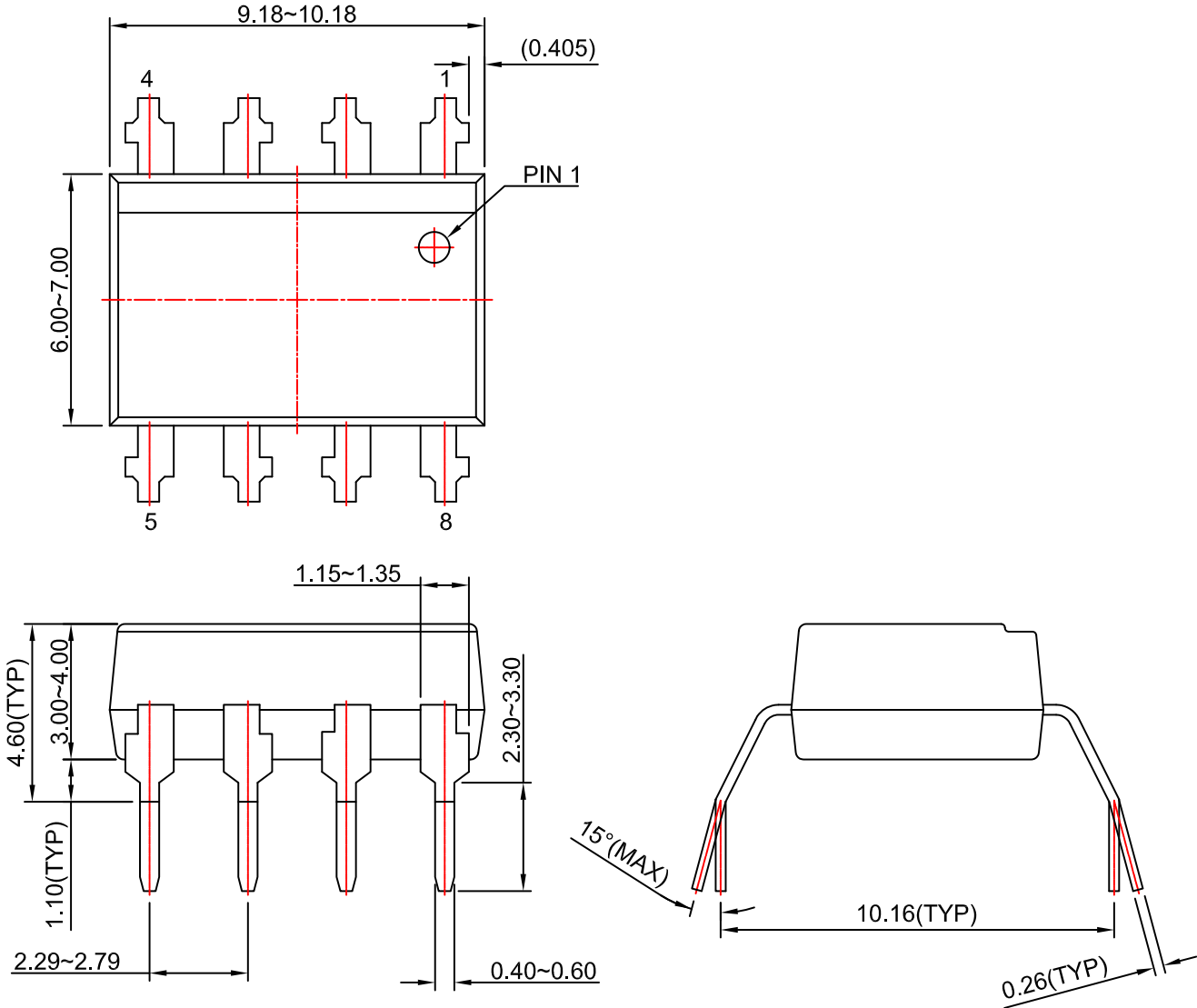

NOTES:

- A) NO STANDARD APPLIES TO THIS PACKAGE.
- B) ALL DIMENSIONS ARE IN MILLIMETERS.
- C) DIMENSIONS ARE EXCLUSIVE OF BURRS, MOLD FLASH, AND TIE BAR EXTRUSION

DOCUMENT NUMBER:	98AON13460G	Electronic versions are uncontrolled except when accessed directly from the Document Repository. Printed versions are uncontrolled except when stamped "CONTROLLED COPY" in red.
DESCRIPTION:	PDIP8 9.68X6.5, 2.54P	PAGE 1 OF 1

ON Semiconductor and are trademarks of Semiconductor Components Industries, LLC dba ON Semiconductor or its subsidiaries in the United States and/or other countries. ON Semiconductor reserves the right to make changes without further notice to any products herein. ON Semiconductor makes no warranty, representation or guarantee regarding the suitability of its products for any particular purpose, nor does ON Semiconductor assume any liability arising out of the application or use of any product or circuit, and specifically disclaims any and all liability, including without limitation special, consequential or incidental damages. ON Semiconductor does not convey any license under its patent rights nor the rights of others.

MECHANICAL CASE OUTLINE

PACKAGE DIMENSIONS

ON Semiconductor®



PDIP8 9.655x6.6, 2.54P
CASE 646CQ
ISSUE O

DATE 18 SEP 2017

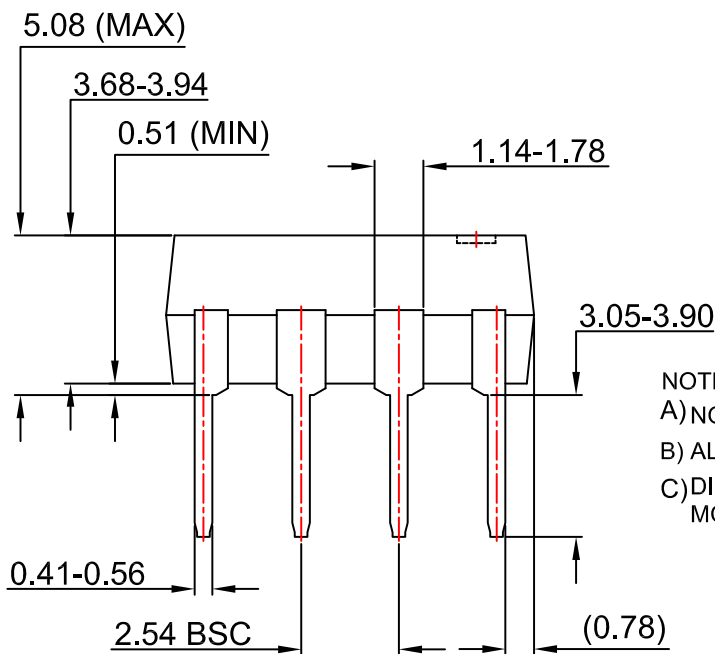
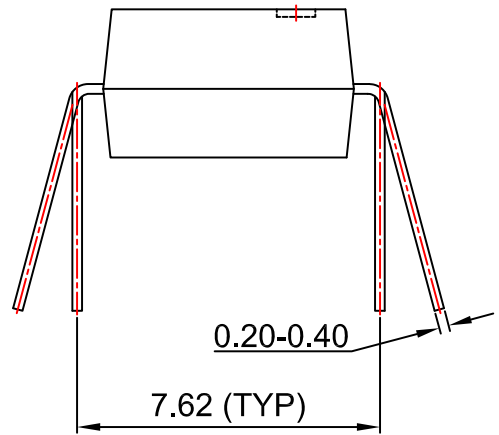
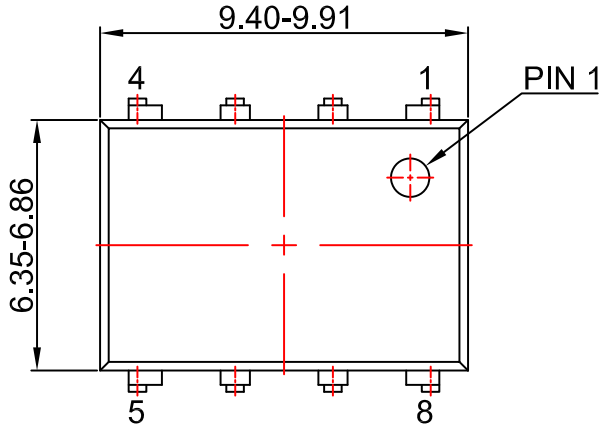

NOTES:
A) NO STANDARD APPLIES TO THIS PACKAGE
B) ALL DIMENSIONS ARE IN MILLIMETERS.
C) DIMENSIONS ARE EXCLUSIVE OF BURRS, MOLD FLASH, AND TIE BAR EXTRUSION

DOCUMENT NUMBER:	98AON13446G	Electronic versions are uncontrolled except when accessed directly from the Document Repository. Printed versions are uncontrolled except when stamped "CONTROLLED COPY" in red.
DESCRIPTION:	PDIP8 9.655X6.6, 2.54P	PAGE 1 OF 1

ON Semiconductor and are trademarks of Semiconductor Components Industries, LLC dba ON Semiconductor or its subsidiaries in the United States and/or other countries. ON Semiconductor reserves the right to make changes without further notice to any products herein. ON Semiconductor makes no warranty, representation or guarantee regarding the suitability of its products for any particular purpose, nor does ON Semiconductor assume any liability arising out of the application or use of any product or circuit, and specifically disclaims any and all liability, including without limitation special, consequential or incidental damages. ON Semiconductor does not convey any license under its patent rights nor the rights of others.

MECHANICAL CASE OUTLINE
PACKAGE DIMENSIONS

PDIP8 GW
CASE 709AF
ISSUE O

DATE 31 AUG 2016

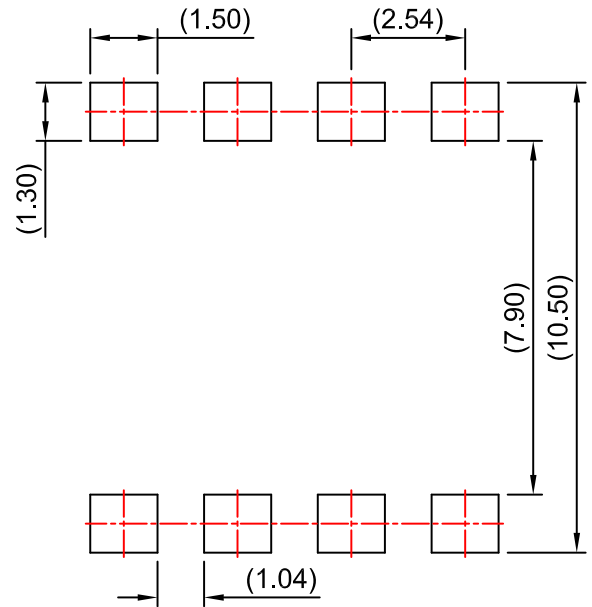
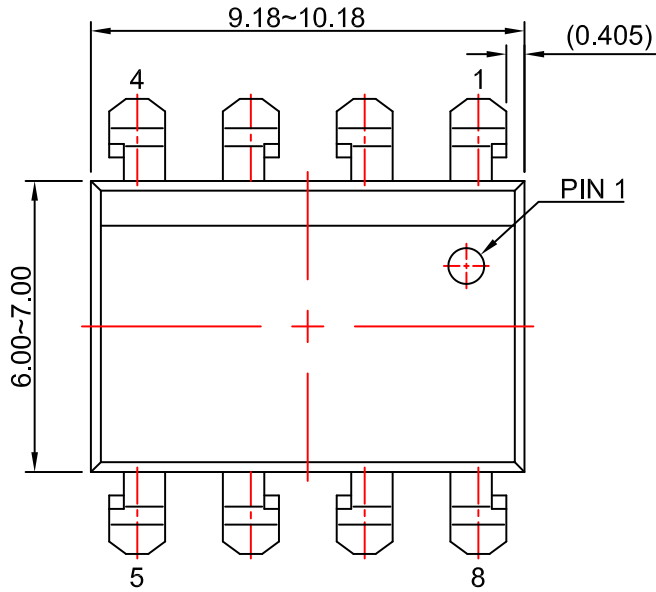

LAND PATTERN RECOMMENDATION

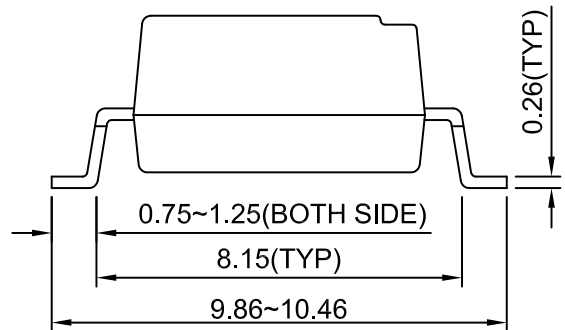
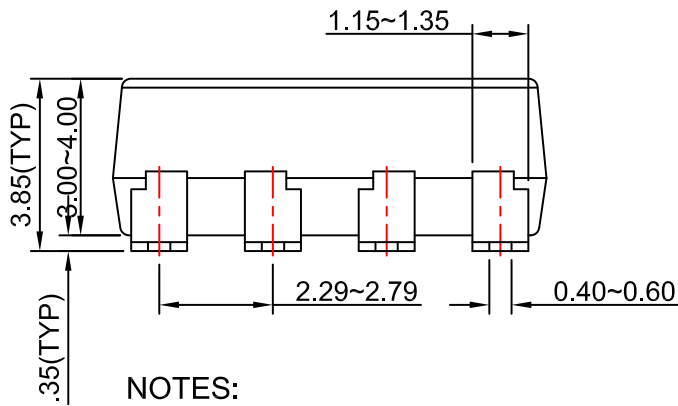

NOTES:

- A) NO STANDARD APPLIES TO THIS PACKAGE.
- B) ALL DIMENSIONS ARE IN MILLIMETERS.
- C) DIMENSIONS ARE EXCLUSIVE OF BURRS, MOLD FLASH, AND TIE BAR EXTRUSION

DOCUMENT NUMBER:	98AON13458G	Electronic versions are uncontrolled except when accessed directly from the Document Repository. Printed versions are uncontrolled except when stamped "CONTROLLED COPY" in red.
STATUS:	ON SEMICONDUCTOR STANDARD	
NEW STANDARD:		
DESCRIPTION:	PDIP8 GW	PAGE 1 OF 2

onsemi, **Onsemi**, and other names, marks, and brands are registered and/or common law trademarks of Semiconductor Components Industries, LLC dba "**onsemi**" or its affiliates and/or subsidiaries in the United States and/or other countries. **onsemi** owns the rights to a number of patents, trademarks, copyrights, trade secrets, and other intellectual property. A listing of **onsemi**'s product/patent coverage may be accessed at www.onsemi.com/site/pdf/Patent-Marking.pdf. **onsemi** reserves the right to make changes at any time to any products or information herein, without notice. The information herein is provided "as-is" and **onsemi** makes no warranty, representation or guarantee regarding the accuracy of the information, product features, availability, functionality, or suitability of its products for any particular purpose, nor does **onsemi** assume any liability arising out of the application or use of any product or circuit, and specifically disclaims any and all liability, including without limitation special, consequential or incidental damages. Buyer is responsible for its products and applications using **onsemi** products, including compliance with all laws, regulations and safety requirements or standards, regardless of any support or applications information provided by **onsemi**. "Typical" parameters which may be provided in **onsemi** data sheets and/or specifications can and do vary in different applications and actual performance may vary over time. All operating parameters, including "Typicals" must be validated for each customer application by customer's technical experts. **onsemi** does not convey any license under any of its intellectual property rights nor the rights of others. **onsemi** products are not designed, intended, or authorized for use as a critical component in life support systems or any FDA Class 3 medical devices or medical devices with a same or similar classification in a foreign jurisdiction or any devices intended for implantation in the human body. Should Buyer purchase or use **onsemi** products for any such unintended or unauthorized application, Buyer shall indemnify and hold **onsemi** and its officers, employees, subsidiaries, affiliates, and distributors harmless against all claims, costs, damages, and expenses, and reasonable attorney fees arising out of, directly or indirectly, any claim of personal injury or death associated with such unintended or unauthorized use, even if such claim alleges that **onsemi** was negligent regarding the design or manufacture of the part. **onsemi** is an Equal Opportunity/Affirmative Action Employer. This literature is subject to all applicable copyright laws and is not for resale in any manner.

ADDITIONAL INFORMATION

TECHNICAL PUBLICATIONS:



Technical Library: www.onsemi.com/design/resources/technical-documentation
onsemi Website: www.onsemi.com

ONLINE SUPPORT: www.onsemi.com/support

For additional information, please contact your local Sales Representative at www.onsemi.com/support/sales

Looking for pricing, stock, or lifecycle information?

Click below to explore more details on WIN SOURCE:

-  [View MCT62 on WIN SOURCE](#)
-  [Fairchild/ON Semiconductor Information](#)

Optimize Your Supply Chain with WIN SOURCE Solutions

-  Global Sourcing Solution
-  Obsolete Management
-  Cost Control Management
-  Shortage Management
-  Alternative Solution
-  Excess Inventory Management