



**THE DATASHEET OF
MD5811-D256-V3Q18-X-P**



Mobile DiskOnChip P3

256Mb Flash Disk with M-Systems' x2 Technology

Preliminary Data Sheet, June 2003

Highlights

Mobile DiskOnChip™ P3, a member of M-Systems' DiskOnChip™ family of optimized memory solutions for new-generation mobile handsets, provides high performance and reliability using NAND flash technology. It combines Toshiba's cutting-edge 0.13 micron NAND flash manufacturing process enhanced for performance and reliability with M-Systems' x2 technology.

Mobile DiskOnChip P3 optimizes real estate and cost structure by incorporating the flash array and an embedded thin controller in a single die. A boot block can be used to boot the OS or initialize the CPU/platform, replacing expensive NOR flash and further reducing memory system costs.

Mobile DiskOnChip P3 provides:

- Flash disk for both code and data storage
- Low voltage: 1.8V or 3.3 I/O (auto-detect), 3V Core
- Hardware protection and security-enabling features
- High capacity: 256Mbit (32MByte)
- Device cascading option: up to 1Gbit (128MByte)
- Enhanced Programmable Boot Block enabling eExecute In Place (XIP) functionality using 16-bit interface
- Small form factors:
 - 48-pin TSOP-I package
 - 85-ball FBGA 7x10x1.2 mm package



- Enhanced performance with:
 - Multi-plane operation
 - DMA support
 - MultiBurst operation
 - Turbo operation
- Unrivalled data integrity with a robust Error Detection Code/Error Correction Code (EDC/ECC)
- Maximized flash endurance with TrueFFS® 6.1 (and higher) flash management software
- Support for major mobile OSs, including: Symbian OS, Pocket PC 2002/3, Smartphone 2002/3, Palm OS, Nucleus, Linux, Windows CE
- Compatible with major mobile CPUs, including TI OMAP, XScale, Motorola DragonBall MX1 and Qualcomm MSMxxxx.

Performance

- MultiBurst read: 80 MB/sec
- Sustained read: 5 MB/sec
- Sustained write: 2.5 MB/sec
- Access time:
 - Normal: 55 nsec
 - Turbo: 33 nsec
 - MultiBurst: 25 nsec

Protection & Security-Enabling Features

- 16-byte Unique Identification (UID) number
- 6KByte user-controlled One Time Programmable (OTP) area
- Two configurable hardware-protected partitions for data and code:
 - Read-only mode
 - Write-only mode
 - One-Time Write mode (ROM-like) partition
 - Protection key and LOCK# signal
 - Sticky Lock (SLOCK) to lock boot partition
 - Protected Bad Block Table

Reliability and Data Integrity

- Hardware- and software-driven, on-the-fly EDC and ECC algorithms
- 4-bit Error Detection Code/Error Correction Code (EDC/ECC), based on a patented combination of BCH and Hamming code algorithms
- Guaranteed data integrity after power failure
- Transparent bad-block management
- Dynamic and static wear-leveling

Boot Capability

- 2KB Programmable Boot Block with XIP capability to replace boot NOR
- Download Engine (DE) for automatic download of boot code from Programmable Boot Block
- Boot options:
 - CPU initialization
 - Platform initialization
 - OS boot
- Asynchronous Boot mode to boot from ARM-based CPUs, e.g. XScale, TI OMAP, without the need for external glue logic
- Exceptional boot performance with MultiBurst operation and DMA support enhanced by external clock

Hardware Compatibility

- Configurable interface: simple NOR-like or multiplexed address/data interface
- CPU compatibility, including:
 - ARM-based CPUs
 - Texas Instruments OMAP
 - Intel StrongARM/XScale
 - Motorola DragonBall MX1
 - Qualcomm MSMxxxx
 - AMD Alchemy
 - Motorola PowerPC™ MPC8xx
 - Philips PR31700
 - Hitachi SuperH™ SH-x
 - NEC VR Series
- Supports 8-, 16- and 32-bit architectures

TrueFFS® Software

- Full hard-disk read/write emulation for transparent file system management
- Patented TrueFFS
 - Flash file system management
 - Automatic block management
 - Data management to maximize the limit of typical flash life expectancy
 - Dynamic virtual mapping
- Dynamic and static wear-leveling
- Programming, duplicating, testing and debugging tools available in source code

Operating Environment

- Wide OS support, including:
 - Symbian OS (EPOC)
 - Pocket PC 2002/3
 - Smartphone 2002/3
 - Palm OS
 - Nucleus
 - Windows CE
 - Linux
- TrueFFS Software Development Kit (SDK) for quick and easy support for proprietary OSs, or OS-less environment
- TrueFFS Boot Software Development Kit (BDK)

Power Requirements

- Operating voltage
 - Core: 2.5V to 3.6V
 - I/O: 1.65 to 2.0V; or 2.5V to 3.6V (auto-detect)
- Current
 - Active: 10 mA
 - Deep Power-Down: 10 μ A

Capacity and Packaging

- 256Mb (32MB) capacity
- Device cascading option for up to four devices (1Gb)
- 48-pin TSOP-I package:
20x12x1.2 mm (width x length x height)
- 85-ball FBGA package:
7x10x1.2 mm (width x length x height)
- Pinout compatible with DiskOnChip Plus TSOP-I products
- Ballout compatible with DiskOnChip Plus 69-ball FBGA products: 9x12x1.4 mm

TABLE OF CONTENTS

1. Introduction	5
2. Product Overview	6
2.1 Product Description	6
2.2 Standard Interface	7
2.2.1 Pin/Ball Diagrams	7
2.2.2 System Interface	9
2.2.3 Signal Description	10
2.3 Multiplexed Interface	14
2.3.1 Pin/Ball Diagram	14
2.3.2 System Interface	16
2.3.3 Signal Description	17
3. Theory of Operation	21
3.1 Overview	21
3.2 System Interface	22
3.2.1 Standard (NOR-Like) Interface	22
3.2.2 Multiplexed Interface	22
3.3 Configuration Interface	23
3.4 Protection and Security-Enabling Features	23
3.4.1 Read/Write Protection	23
3.4.2 Unique Identification (UID) Number	23
3.4.3 One-Time Programmable (OTP) Area	24
3.4.4 One-Time Write (ROM-Like) Partition	24
3.4.5 Sticky Lock (SLOCK)	24
3.5 Programmable Boot Block with eExecute In Place (XIP) Functionality	24
3.6 Download Engine (DE)	25
3.7 Error Detection Code/Error Correction Code (EDC/ECC)	25
3.8 Data Pipeline	25
3.9 Control and Status	25
3.10 Flash Architecture	26
4. x2 Technology	28
4.1 MultiBurst Operation	28
4.2 DMA Operation	30
4.3 Combined MultiBurst Mode and DMA Operation	31

4.4	Turbo Operation	31
5.	Hardware Protection	32
5.1	Method of Operation	32
5.2	Low-Level Structure of the Protected Area	33
6.	Modes of Operation	35
6.1	Normal Mode	36
6.2	Reset Mode	36
6.3	Deep Power-Down Mode	36
7.	TrueFFS Technology	38
7.1	General Description	38
7.1.1	Built-In Operating System Support	39
7.1.2	TrueFFS Software Development Kit (SDK)	39
7.1.3	File Management	39
7.1.4	Bad Block Management	39
7.1.5	Wear-Leveling	39
7.1.6	Power Failure Management	40
7.1.7	Error Detection/Correction	40
7.1.8	Special Features Through I/O Control (IOCTL) Mechanism	41
7.1.9	Compatibility	41
7.2	8KB Memory Window	41
8.	Register Descriptions	42
8.1	Definition of Terms	42
8.2	Reset Values	42
8.3	No Operation (NOP) Register	43
8.4	Chip Identification (ID) Register [0:1]	43
8.5	Test Register	43
8.6	Bus Lock Register	44
8.7	Endian Control Register	45
8.8	DiskOnChip Control Register/Control Confirmation Register	46
8.9	Device ID Select Register	47
8.10	Configuration Register	47
8.11	Interrupt Control Register	48
8.12	Interrupt Status Register	49
8.13	Output Control Register	50
8.14	DPD Control Register	51

8.15	DMA Control Register [1:0].....	52
8.16	MultiBurst Mode Control Register.....	54
9.	Bootting from Mobile DiskOnChip P3.....	55
9.1	Introduction.....	55
9.2	Boot Procedure in PC-Compatible Platforms	55
9.3	Boot Replacement.....	56
9.3.1	PC Architectures	56
9.3.2	Non-PC Architectures.....	57
9.3.3	Asynchronous Boot Mode	57
10.	Design Considerations	58
10.1	General Guidelines.....	58
10.2	Standard NOR-Like Interface	59
10.3	Multiplexed Interface	60
10.4	Connecting Control Signals	60
10.4.1	Standard Interface.....	60
10.4.2	Multiplexed Interface	61
10.5	Implementing the Interrupt Mechanism	62
10.5.1	Hardware Configuration	62
10.5.2	Software Configuration.....	62
10.6	Device Cascading.....	63
10.7	Boot Replacement.....	64
10.8	Platform-Specific Issues	65
10.8.1	Wait State	65
10.8.2	Big and Little Endian Systems.....	65
10.8.3	Busy Signal.....	65
10.8.4	Working with 8/16/32-Bit Systems.....	65
10.9	Design Environment	67
11.	Product Specifications	68
11.1	Environmental Specifications	68
11.1.1	Operating Temperature	68
11.1.2	Thermal Characteristics	68
11.1.3	Humidity.....	68
11.1.4	Endurance	68
11.2	Electrical Specifications.....	68
11.2.1	Absolute Maximum Ratings.....	68
11.2.2	Capacitance.....	69

11.2.3 DC Electrical Characteristics Over Operating Range	69
11.2.4 AC Operating Conditions.....	70
11.3 Timing Specifications.....	71
11.3.1 Read Cycle Timing Standard Interface	71
11.3.2 Write Cycle Timing Standard Interface	73
11.3.3 Read Cycle Timing Multiplexed Interface.....	74
11.3.4 Write Cycle Timing Multiplexed Interface.....	75
11.3.5 Read Cycle Timing MultiBurst.....	76
11.3.6 Power Supply Sequence	77
11.3.7 Power-up Timing	77
11.3.8 Interrupt Timing	79
11.3.9 DMA Request Timing	79
11.4 Mechanical Dimensions.....	80
12. Ordering Information.....	82
How to Contact Us	83

1. INTRODUCTION

This data sheet includes the following sections:

- Section 1:** Overview of data sheet contents
- Section 2:** Product overview, including a brief product description, ball diagrams and signal descriptions
- Section 3:** Theory of operation for the major building blocks
- Section 4:** Major features and benefits of x2 technology
- Section 5:** Detailed description of hardware protection and security-enabling features
- Section 6:** Modes of operation
- Section 7:** TrueFFS technology, including power failure management and 8KByte memory window
- Section 8:** Register descriptions
- Section 9:** Booting from Mobile DiskOnChip P3
- Section 10:** Hardware and software design considerations
- Section 11:** Environmental, electrical, timing and product specifications
- Section 12:** Information on ordering Mobile DiskOnChip P3

For additional information on M-Systems' flash disk products, please contact one of the offices listed on the back page.

2. PRODUCT OVERVIEW

2.1 Product Description

Mobile DiskOnChip P3, packed in the smallest available FBGA package with 256Mb (32MB) capacity, is a single-die device with an embedded thin flash controller and flash memory. It uses Toshiba's cutting-edge, 0.13 micron NAND-based flash manufacturing process, enhanced by M-Systems' proprietary x2 technology.

M-Systems' x2 technology provides performance enhancement with multi-plane operation, DMA support, turbo operation and MultiBurst operation. The combination of NAND flash and x2 technology results in a low-cost, minimal-sized flash disk that achieves unsurpassed reliability levels and enhanced performance.

This breakthrough in performance, size and cost makes Mobile DiskOnChip P3 the ideal solution for mobile product manufacturers who require high-capacity, small size, high-performance, and above all, high-reliability storage to enable applications such as enhanced Multimedia Messaging Service (MMS), gaming, video and Personal Information Management (PIM) on mobile handsets and Personal Digital Assistants (PDAs).

Mobile DiskOnChip P3 content protection and security-enabling features offer several benefits. Two write- and read-protected partitions, with both software- and hardware-based protection, can be configured independently for maximum design flexibility. The 16-byte Unique ID (UID) identifies each flash device, eliminating the need for a separate ID device on the motherboard. The 6KB One Time Programmable (OTP) area, written to once and then locked to prevent data and code from being altered, is ideal for storing customer and product-specific information.

Mobile DiskOnChip P3 256Mb has a 2KB Programmable Boot Block. This block provides eExecute In Place (XIP) functionality, enabling Mobile DiskOnChip P3 to replace the boot device and function as the only non-volatile memory device on-board. Eliminating the need for an additional boot device reduces hardware expenditures, board real estate, programming time, and logistics.

M-Systems' patented TrueFFS software technology fully emulates a hard disk to manage the files stored on Mobile DiskOnChip P3. This transparent file system management enables read/write operations that are identical to a standard, sector-based hard disk. In addition, TrueFFS employs patented methods, such as virtual mapping, dynamic and static wear-leveling, and automatic block management to ensure high data reliability and to maximize flash life expectancy.

2.2 Standard Interface

2.2.1 Pin/Ball Diagrams

See Figure 1 and Figure 2 for the Mobile DiskOnChip P3 256Mb pinout/ballout for the standard interface. To ensure proper device functionality, pins/balls marked RSRVD are reserved for future use and should not be connected.

Note: Mobile DiskOnChip P3 is designed as a drop-in replacement for second-generation (G2) DiskOnChip Plus products, assuming that the latter were integrated according to migration guide guidelines. Refer to application note AP-DOC-067, *Preparing your PCB Footprint for the DiskOnChip BGA Migration Path*, for further information.

TSOP-I Package



Figure 1: TSOP-I Pinout for Standard Interface (Mobile DiskOnChip P3 256Mb)

7x10 FBGA Package

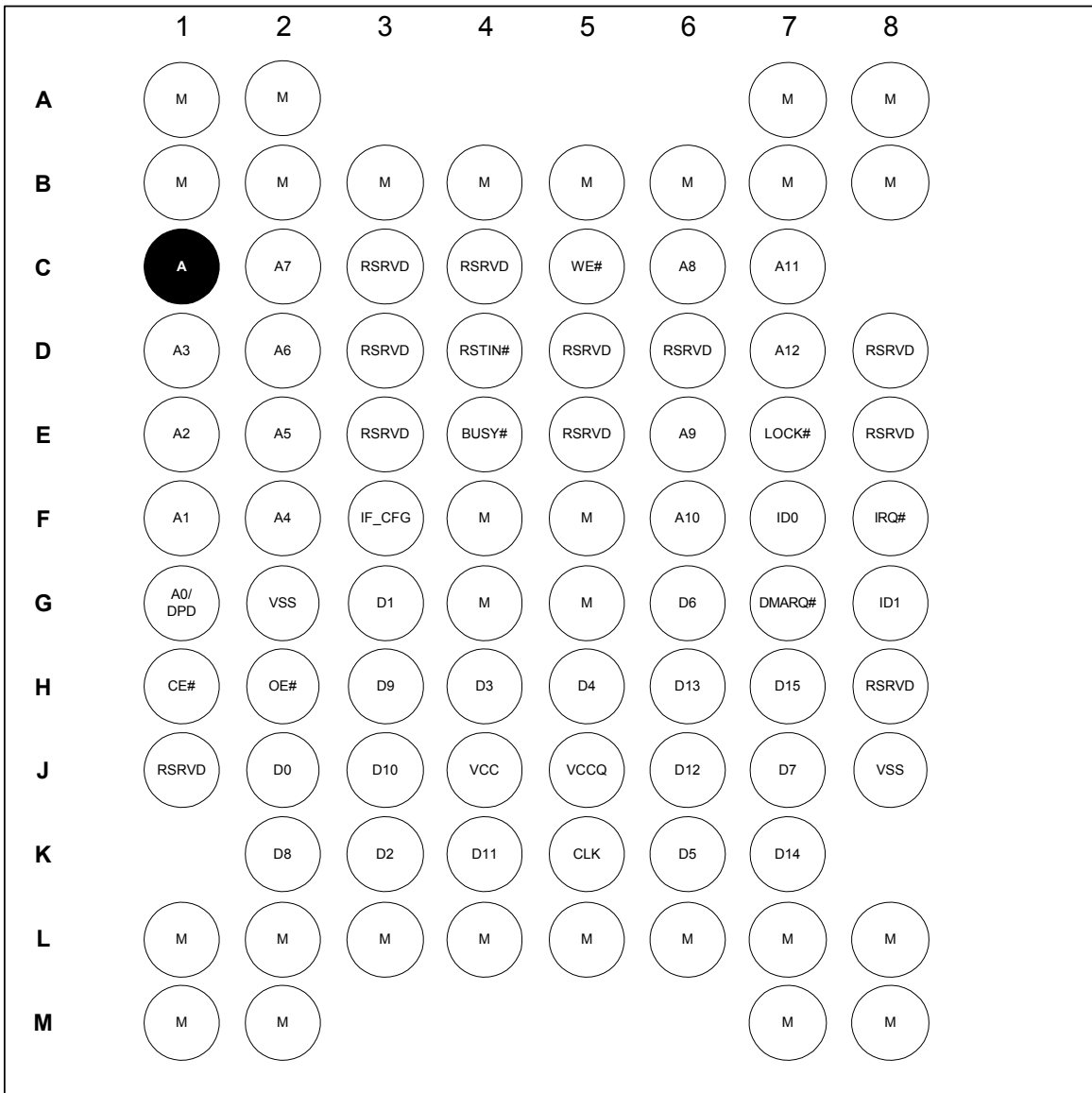

Figure 2: 7x10 FBGA Ballout for Standard Interface (Mobile DiskOnChip P3 256Mb)

2.2.2 System Interface

See Figure 3 for a simplified I/O diagram for a standard interface of Mobile DiskOnChip P3 256Mb.

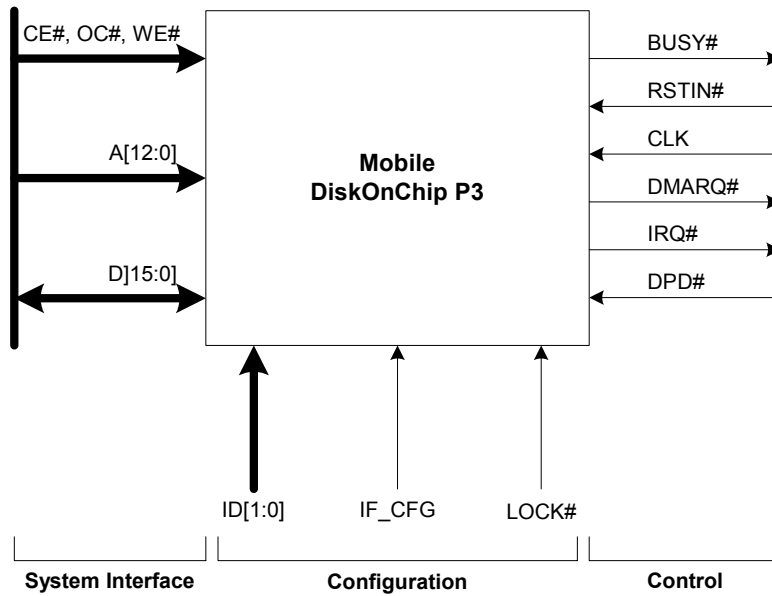

Figure 3: Standard Interface Simplified I/O Diagram (Mobile DiskOnChip P3 256Mb)

2.2.3 Signal Description

Mobile DiskOnChip P3 TSOP-I and FBGA packages support identical signals. The related pin and ball designations are listed in the signal descriptions, presented in logic groups, in Table 1 and Table 2.

TSOP-I Package

Table 1: Signal Descriptions for Standard Interface (Mobile DiskOnChip P3 256Mb TSOP-I Package)

Signal	Pin No.	Input Type	Description	Signal Type
System Interface				
A[12:6] A[5:0]	5-11 14-19	ST	Address bus. A0 is multiplexed with the DPD pin.	Input
D[15:8]	46-39	ST, R8	Data bus, high byte. Not used and may be left floating when IF_CFG is set to 0 (8-bit mode).	Input/ Output
D[7:0]	35-28	ST	Data bus, low byte.	Input/ Output
CE#	2	ST	Chip Enable, active low	Input
WE#	3	ST	Write Enable, active low	Input
OE#	4	ST	Output Enable, active low	Input
Configuration				
ID[1:0]	26, 24	ST	Identification. Configuration control to support up to four chips cascaded in the same memory window. Chip 1 = ID1, ID0 = VSS, VSS (0,0); must be used for single-chip configuration Chip 2 = ID1, ID0 = VSS, VCCQ (0,1) Chip 3 = ID1, ID0 = VCCQ, VSS (1,0) Chip 4 = ID1, ID0 = VCCQ, VCCQ (1,1)	Input
LOCK#	23	ST	Lock, active low. When active, provides full hardware data protection of selected partitions.	Input
IF_CFG	22	ST	Interface Configuration, 1(VCCQ) for 16-bit interface mode, 0 (VSS) for 8-bit interface mode.	Input
Control				
BUSY#	27	OD	Busy, active low, open drain. Indicates that DiskOnChip is initializing and should not be accessed. A 10 K Ω pull-up resistor is required if this pin drives an input. A 10 K Ω pull-up resistor is recommended even if this pin is not used.	Output
RSTIN#	1	ST	Reset, active low.	Input
CLK	38	ST	System Clock.	Input

Signal	Pin No.	Input Type	Description	Signal Type
DMARQ#	21	OD	DMA Request, active low. A 10 K Ω pull-up resistor is required if this pin drives an input. A 10 K Ω pull-up resistor is recommended even if this pin is not used.	Output
IRQ#	47	OD	Interrupt Request, active low. A 10 K Ω pull-up resistor is required if this pin drives an input. A 10 K Ω pull-up resistor is recommended even if this pin is not used.	Output
DPD	19	ST	Deep Power-Down. Used to enter and exit Deep Power-Down mode. This pin is assigned A0 instead of DPD when working in 8-bit mode.	Input
Power				
VCC	12	-	Device core power supply. Requires a 10 nF and 0.1 μ F capacitor.	Supply
VCCQ	37	-	I/O power supply. Sets the logic 1 voltage level range of I/O pins. VCCQ may be either 2.5V to 3.6V or 1.65V to 2.0V. Requires a 10 nF and 0.1 μ F capacitor.	Supply
VSS	13, 25, 36, 48	-	Ground. All VSS pins must be connected.	Supply
Other				
RSRVD	20	-	Reserved. All reserved signals are not connected internally and must be left floating to guarantee forward compatibility with future products.	

The following abbreviations are used: IN - Standard (non-Schmidt) input, ST - Schmidt Trigger input, OD - Open drain output, R8 - Nominal 22K pull-up resistor, enabled only for 8-bit interface mode (IF_CFG input is 0)

7x10 FBGA Package
Table 2: Signal Descriptions for Standard Interface (Mobile DiskOnChip P3 256Mb 7x10 FBGA Package)

Signal	Ball No.	Input Type	Description	Signal Type
System Interface				
A[12:11] A[10:8] A[7:4] A[3:0]	D7, C7 F6, E6, C6 C2, D2, E2, F2 D1, E1, F1, G1	ST	Address bus. A0 is multiplexed with the DPD ball.	Input
D[15:14] D[13:12] D[11:8]	H7, K7 H6, J6 K4, J3, H3, K2	ST, R8	Data bus, high byte. Not used and may be left floating when IF_CFG is set to 0 (8-bit mode).	Input/ Output
D[7:6] D[5:3] D[2:0]	J7, G6 K6, H5, H4 K3, G3, J2	ST	Data bus, low byte.	Input/ Output
CE#	H1	ST	Chip Enable, active low	Input
OE#	H2	ST	Write Enable, active low	Input
WE#	C5	ST	Output Enable, active low	Input
Configuration				
ID[1:0]	G8, F7	ST	Identification. Configuration control to support up to four chips cascaded in the same memory window. Chip 1 = ID1, ID0 = VSS, VSS (0,0); must be used for single chip configuration Chip 2 = ID1, ID0 = VSS, VCCQ (0,1) Chip 3 = ID1, ID0 = VCCQ, VSS (1,0) Chip 4 = ID1, ID0 = VCCQ, VCCQ (1,1)	Input
LOCK#	E7	ST	Lock, active low. When active, provides full hardware data protection of selected partitions.	Input
IF_CFG	F3	ST	Interface Configuration, 1 (VCCQ) for 16-bit interface mode, 0 (VSS) for 8-bit interface mode.	Input
Control				
BUSY#	E4	OD	Busy, active low, open drain. Indicates that DiskOnChip is initializing and should not be accessed. A 10 K Ω pull-up resistor is required if this ball drives an input. A 10 K Ω pull-up resistor is recommended even if this ball is not used.	Output
RSTIN#	D4	ST	Reset, active low.	Input
CLK	K5	ST	System Clock.	Input
DMARQ#	G7	OD	DMA Request, active low. A 10 K Ω pull-up resistor is required if this ball drives an input. A 10 K Ω pull-up resistor is recommended even if this ball is not used.	Output

Signal	Ball No.	Input Type	Description	Signal Type
IRQ#	F8	OD	Interrupt Request, active low. A 10 K Ω pull-up resistor is required if this ball drives an input. A 10 K Ω pull-up resistor is recommended even if this ball is not used.	Output
DPD	G1	ST	Deep Power-Down. Used to enter and exit Deep Power-Down mode. This ball is assigned A0 instead of DPD when working in 8-bit mode.	Input
Power				
VCC	J4	-	Device supply. Requires a 10 nF and 0.1 μ F capacitor.	Supply
VCCQ	J5	-	I/O power supply. Sets the logic 1 voltage level range of I/O balls. VCCQ may be either 2.5V to 3.6V or 1.65V to 2.0V. Requires a 10 nF and 0.1 μ F capacitor.	Supply
VSS	G2, J8	-	Ground. All VSS balls must be connected.	Supply
Other				
RSRVD	See Figure 2	-	Reserved. All reserved signals are not connected internally and must be left floating to guarantee forward compatibility with future products.	
	M	-	Mechanical. These balls are for mechanical placement, and are not connected internally.	
	A	-	Alignment. This ball is for device alignment and is not connected internally.	

The following abbreviations are used: IN - Standard (non-Schmidt) input, ST - Schmidt Trigger input, OD - Open drain output, R8 - Nominal 22K pull-up resistor, enabled only for 8-bit interface mode (IF_CFG input is 0)

2.3 Multiplexed Interface

2.3.1 Pin/Ball Diagram

See Figure 4 and Figure 5 for the Mobile DiskOnChip P3 256Mb pinout/ballout for the multiplexed interface. To ensure proper device functionality, pins/balls marked RSRVD are reserved for future use and should not be connected.

Note: Mobile DiskOnChip P3 is designed as a drop-in replacement for second-generation (G2) DiskOnChip Plus products, assuming that the latter were integrated according to migration guide guidelines. Refer to application note AP-DOC-067, *Preparing your PCB Footprint for the DiskOnChip BGA Migration Path*, for further information.

TSOP-I Package



Figure 4: Pinout for Multiplexed Interface (Mobile DiskOnChip P3 256Mb TSOP-I Package)

7x10 FBGA Package

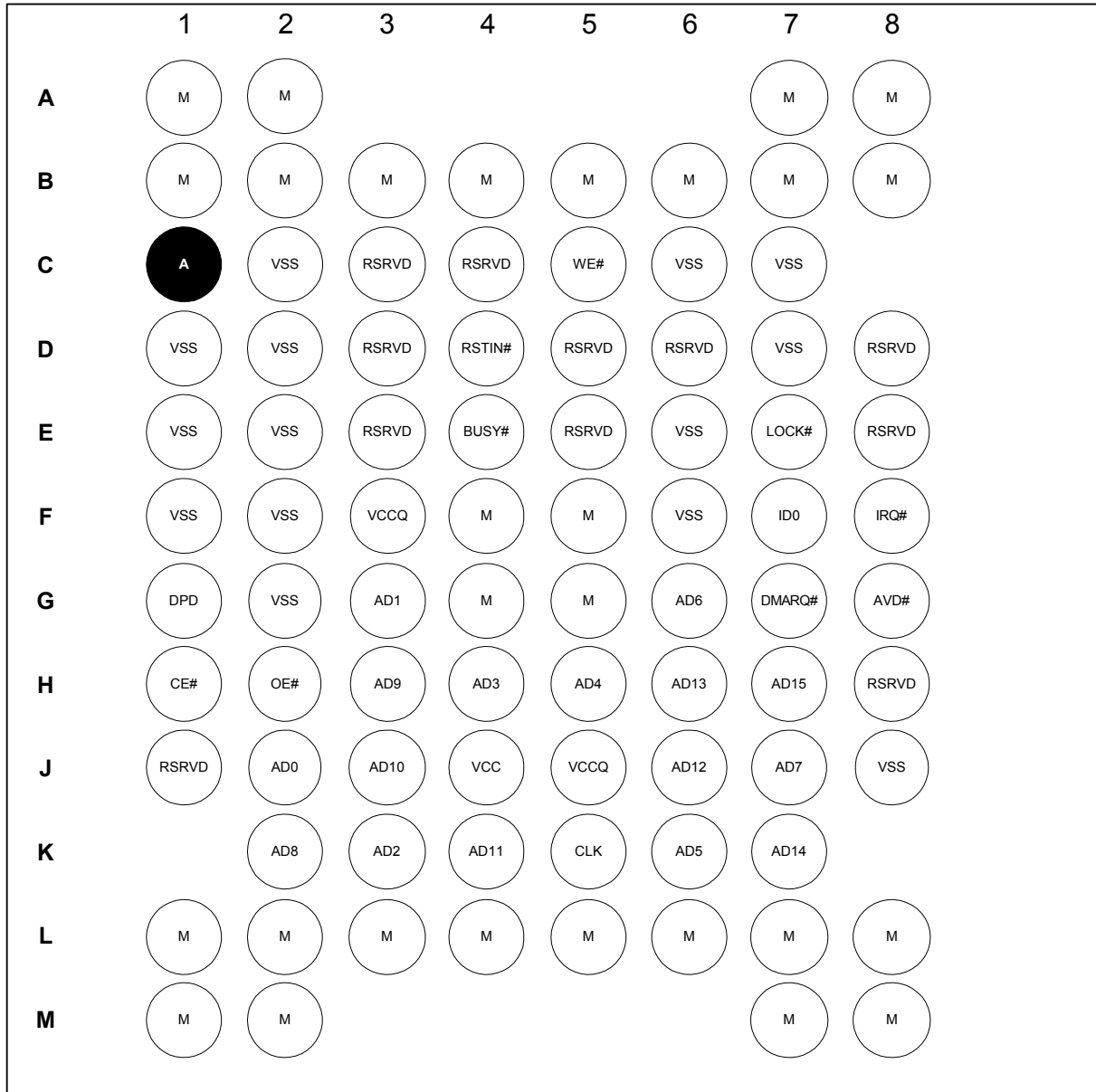

Figure 5 Ballout for Multiplexed Interface (Mobile DiskOnChip P3 256Mb 7x10 FBGA Package)

2.3.2 System Interface

See Figure 6 for a simplified I/O diagram.

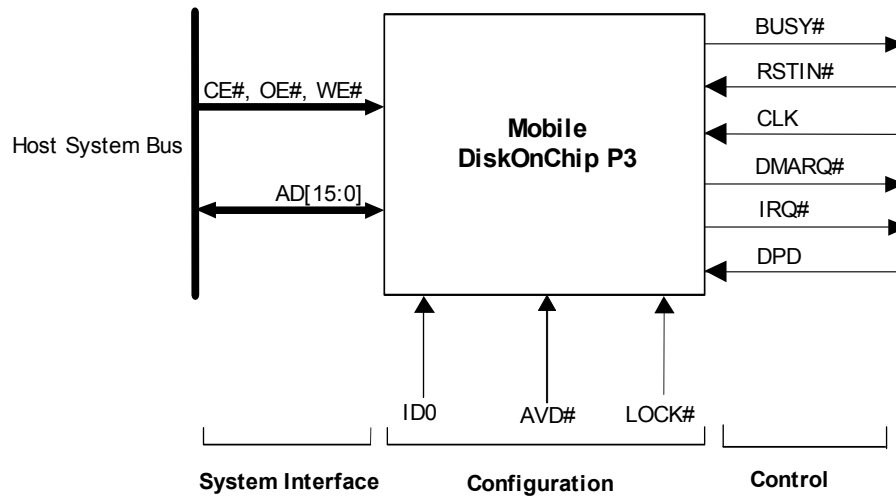

Figure 6: Multiplexed Interface Simplified I/O Diagram

2.3.3 Signal Description

Mobile DiskOnChip P3 256Mb TSOP-I and 7x10 FBGA packages support identical signals in the multiplexed interface. The related pin/ball designations are listed in the signal descriptions, presented in logic groups, in Table 3 and Table 4.

TSOP-I Package

Table 3: Signal Descriptions for Multiplexed Interface (Mobile DiskOnChip P3 256Mb TSOP-I Package)

Signal	Pin No.	Input Type	Description	Signal Type
System Interface				
AD[15:0]	28-35, 39-46	ST	Multiplexed bus. Address and data signals.	Input/Output
CE#	2	ST	Chip Enable, active low.	Input
WE#	3	ST	Write Enable, active low.	Input
OE#	4	ST	Output Enable, active low.	Input
Configuration				
AVD#	26	ST	Set multiplexed interface.	Input
ID0	24	ST	Identification. Configuration control to support up to two chips cascaded in the same memory window. Chip 1 = ID0 = VSS; must be used for single-chip configuration Chip 2 = ID0 = VCCQ	Input
LOCK#	23	ST	Lock, active low. When active, provides full hardware data protection of selected partitions.	Input
Control				
BUSY#	27	OD	Busy, active low, open drain. Indicates that DiskOnChip is initializing and should not be accessed. A 10 K Ω pull-up resistor is required if this pin drives an input. A 10 K Ω pull-up resistor is recommended even if this pin is not used.	Output
RSTIN#	1	ST	Reset, active low.	Input
CLK	38	ST	System Clock.	Input
DMARQ#	21	OD	DMA Request, active low. A 10 K Ω pull-up resistor is required if this pin drives an input. A 10 K Ω pull-up resistor is recommended even if this pin is not used.	
IRQ#	47	OD	Interrupt Request, active low. A 10 K Ω pull-up resistor is required if this pin drives an input. A 10 K Ω pull-up resistor is recommended even if this pin is not used.	Output
DPD	19	ST	Deep Power-Down. Used to enter and exit Deep Power-Down mode.	Input

Signal	Pin No.	Input Type	Description	Signal Type
Power				
VCCQ	37,22	-	I/O power supply. Sets the logic 1 voltage level range of I/O pins. VCCQ may be either 2.5V to 3.6V or 1.65V to 2.0V. Requires a 10 nF and 0.1 μ F capacitor.	Supply
VCC	12	-	Device core supply. Requires a 10 nF and 0.1 μ F capacitor.	Supply
VSS	5-11, 14-18, 13, 25, 36, 48	-	Ground. All VSS pins must be connected.	Supply
Reserved				
RSRVD	20	-	Reserved signal that is not connected internally and must be left floating to guarantee forward compatibility with future products. It should not be connected to arbitrary signals.	

The following abbreviations are used: IN - Standard (non-Schmidt) input, ST - Schmidt Trigger input, OD - Open drain output

7x10 FBGA Package
Table 4: Signal Descriptions for Multiplexed Interface (Mobile DiskOnChip P3 7x10 FBGA Package)

Signal	Ball No.	Input Type	Description	Signal Type
System Interface				
AD[15:14]	H7, K7	ST	Multiplexed bus. Address and data signals	Input/Output
AD[13:12]	H6, J6			
AD[11:9]	K4, J3, H3			
AD[8:6]	K2, J7, G6			
AD[5:3]	K6, H5, H4			
AD[2:0]	K3, G3, J2			
CE#	H1	ST	Chip Enable, active low	Input
OE#	H2	ST	Write Enable, active low	Input
WE#	C5	ST	Output Enable, active low	Input
Configuration				
AVD#	G8	ST	Set multiplexed interface	Input
ID0	F7	ST	Identification. Configuration control to support up to two chips cascaded in the same memory window. Chip 1 = ID0 = VSS; must be used for single-chip configuration Chip 2 = ID0 = VCC	Input
LOCK#	E7	ST	Lock, active low. When active, provides full hardware data protection of selected partitions.	Input
Control				
BUSY#	E4	OD	Busy, active low, open drain. Indicates that DiskOnChip is initializing and should not be accessed. A 10 K Ω pull-up resistor is required if this ball drives an input. A 10 K Ω pull-up resistor is recommended even if this ball is not used.	Output
RSTIN#	D4	ST	Reset, active low.	Input
CLK	K5	ST	System Clock.	Input
DMARQ#	G7	OD	DMA Request, active low. A 10 K Ω pull-up resistor is required if this ball drives an input. A 10 K Ω pull-up resistor is recommended even if this ball is not used.	Output
IRQ#	F8	OD	Interrupt Request, active low. A 10 K Ω pull-up resistor is required if this ball drives an input. A 10 K Ω pull-up resistor is recommended even if this ball is not used.	Output
DPD	G1	ST	Deep Power-Down. Used to enter and exit Deep Power-Down mode.	Input

Signal	Ball No.	Input Type	Description	Signal Type
Power				
VCC	J4	-	Device core supply. Requires a 10 nF and 0.1 μ F capacitor.	Supply
VCCQ	J5, F3	-	I/O power supply. Sets the logic 1 voltage level range of I/O balls. VCCQ may be either 2.5V to 3.6V or 1.65V to 2.0V. Requires a 10 nF and 0.1 μ F capacitor.	Supply
VSS	G2,J8, D7,C7,F6,E6, C6,C2,D2,E2 ,F2,D1,E1,F1	-	Ground. All VSS pins must be connected.	Supply
Other				
RSRVD	See Figure 5	-	Reserved. All reserved signals are not connected internally and must be left floating to guarantee forward compatibility with future products.	
	M		Mechanical. These balls are for mechanical placement, and are not connected internally.	
	A	-	Alignment. This ball is for device alignment and is not connected internally.	

The following abbreviations are used: IN - Standard (non-Schmidt) input, ST - Schmidt Trigger input, OD - Open drain output

3. THEORY OF OPERATION

3.1 Overview

Mobile DiskOnChip P3 consists of the following major functional blocks, as shown in Figure 7.

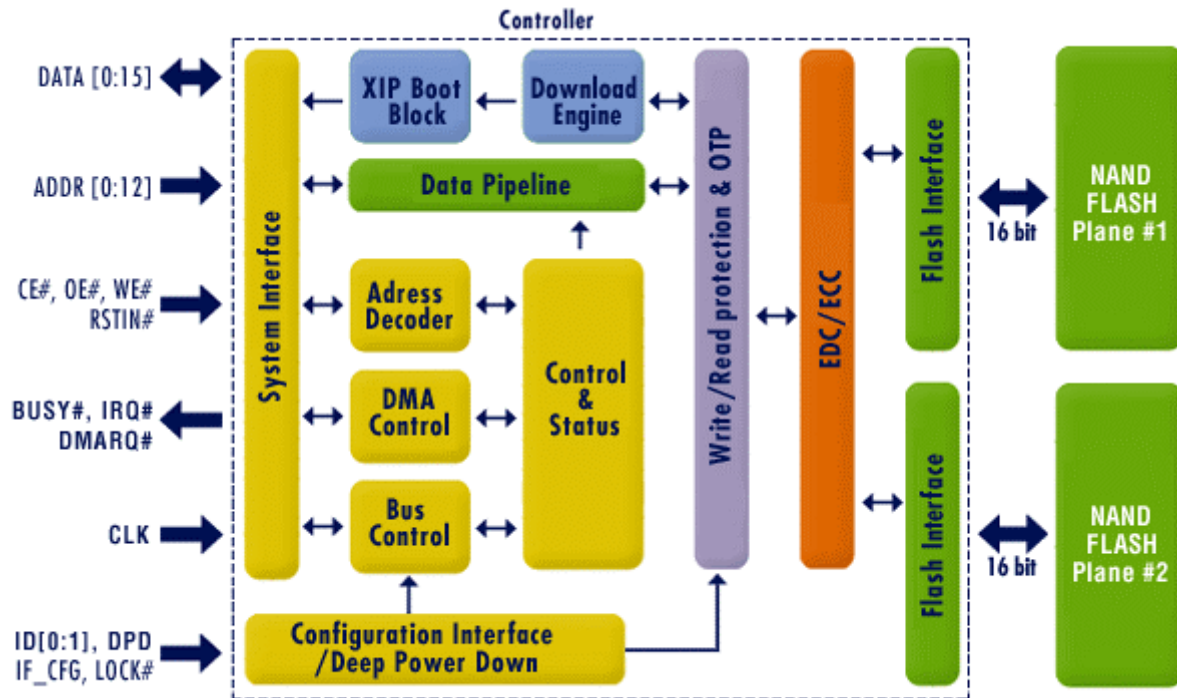

*ADDR[0] and DPD are multiplexed on the same ball/pin.

Figure 7: Mobile DiskOnChip P3 Simplified Block Diagram, Standard Interface

These components are described briefly below and in more detail in the following sections.

- **System Interface** for the host interface.
- **Configuration Interface** for configuring Mobile DiskOnChip P3 to operate in 8-bit, 16-bit or 32-bit mode, cascaded configuration, hardware read/write protection and entering/exiting Deep Power-Down mode.
- **Read/Write Protection and OTP** for advanced data/code security and protection.
- **Programmable Boot Block with XIP** functionality enhanced with a **Download Engine (DE)** for system initialization capability.
- **Error Detection and Error Correction Code (EDC/ECC)** for on-the-fly error handling.
- **Data Pipeline** through which the data flows from the system to the NAND flash arrays.
- **Control & Status** block that contains registers responsible for transferring the address, data and control information between the TrueFFS driver and the flash media.
- **Flash Interface** that interfaces to two NAND flash planes.

- **Bus Control** for translating the host bus address, and data and control signals into valid NAND flash signals.
- **Address Decoder** to enable the relevant unit inside the DiskOnChip controller, according to the address range received from the system interface.

3.2 System Interface

3.2.1 Standard (NOR-Like) Interface

The system interface block provides an easy-to-integrate NOR-like (also SRAM and EEPROM-like) interface to Mobile DiskOnChip P3, enabling it to interface with various CPU interfaces, such as a local bus, ISA bus, NOR interface, SRAM interface, EEPROM interface or any other compatible interface. In addition, the EEPROM-like interface enables direct access to the Programmable Boot Block to permit XIP (Execute-In-Place) functionality during system initialization.

A 13-bit wide address bus enables access to the Mobile DiskOnChip 8KB memory window (as shown in Section 7.2). A 16-bit internal data bus is supported by parallel access to two 128Mb flash planes (for 256Mb single-die devices), each of which enables 8-bit access. This 16-bit data bus permits 16-bit wide access to the host.

The Chip Enable (CE#), Write Enable (WE#) and Output Enable (OE#) signals trigger read and write cycles. A write cycle occurs while both the CE# and the WE# inputs are asserted. Similarly, a read cycle occurs while both the CE# and OE# inputs are asserted. Note that Mobile DiskOnChip P3 does not require a clock signal. It features a unique analog static design, optimized for minimal power consumption. The CE#, WE# and OE# signals trigger the controller (e.g., system interface block, bus control and data pipeline) and flash access.

The Reset In (RSTIN#) and Busy (BUSY#) control signals are used in the reset phase.

The Interrupt Request (IRQ#) signal can be used when long I/O operations, such as Block Erase, delay the CPU resources. The signal is also asserted when a Data Protection violation has occurred. This signal frees the CPU to run other tasks, continuing read/write operations with Mobile DiskOnChip P3 only after the IRQ# signal has been asserted and an interrupt handling routine (implemented in the OS) has been called to return control to the TrueFFS driver.

The DMARQ# output is used to control multi-page DMA operations, and the CLK input is used to support MultiBurst operation when reading flash data. See Section 4.1 for further information.

3.2.2 Multiplexed Interface

In this configuration, the address and data signals are multiplexed. The ID[1] input is driven by the host AVD# signal, and the D[15:0] pins/balls, used for both address inputs and data, are connected to the host AD[15:0] bus. While AVD# is asserted, the host drives AD[11:0] with bits [12:1] of the address. Host signals AD[15:12] are not significant during this part of the cycle.

This interface is automatically used when a falling edge is detected on ID[1]. This edge must occur after RSTIN# is negated and before the first read or write cycle to the controller. When using a multiplexed interface, the value of ID[1] is internally forced to logic-0. The only possible device ID values are 0 and 1; therefore, only up to two Mobile DiskOnChip P3 256Mb devices may be cascaded in multiplexed configuration.

3.3 Configuration Interface

The Configuration Interface block enables the designer to configure Mobile DiskOnChip P3 to operate in different modes. The ID[1:0] signals are used in a cascaded configuration (refer to Section 10.6), the DPD signal is used to enter and exit Deep Power-Down mode (see Section 6.3), the LOCK# signal is used for hardware write/read protection, and the IF_CFG signal is used to configure 8/16-bit access.

3.4 Protection and Security-Enabling Features

The Protection and Security-Enabling block, consisting of read/write protection, UID and an OTP area, enables advanced data and code security and content protection. Located on the main route of traffic between the host and the flash, this block monitors and controls all data and code transactions to and from Mobile DiskOnChip P3.

3.4.1 Read/Write Protection

Data and code protection is implemented through a Protection State Machine (PSM). The user can configure one or two independently programmable areas of the flash memory as read protected, write protected, or read/write protected.

A protected partition may be protected by either/both of these hardware mechanisms:

- 64-bit protection key
- Hard-wired LOCK# signal

If the Lock option is enabled (by means of software) and the LOCK# signal is asserted, the protected partition has an additional hardware lock that prevents read/write access to the partition, even with the use of the correct protection key. The LOCK# signal must be asserted during formatting (and later when the partition is defined as changeable) to enable the additional hardware safety lock.

Only one partition can be defined as “changeable”; i.e., its password and attributes are fully configurable at any time (from read to write, both or none and vice versa). Note that “unchangeable” partition attributes cannot be changed unless the media is reformatted.

The size and protection attributes of the protected partition are defined during the media-formatting stage.

In the event of an attempt to bypass the protection mechanism, illegally modify the protection key or in any way sabotage the configuration parameters, the entire Mobile DiskOnChip P3 becomes both read and write protected, and is completely inaccessible.

For further information on hardware protection, please refer to the *TrueFFS Software Development Kit (SDK)* developer guide.

3.4.2 Unique Identification (UID) Number

Each Mobile DiskOnChip P3 is assigned a 16-byte UID number. Burned onto the flash during production, the UID cannot be altered and is unique worldwide. The UID is essential in security-related applications, and can be used to identify end-user products in order to fight fraudulent duplication by imitators.

3.4.3 One-Time Programmable (OTP) Area

The 6KB OTP area is user programmable for complete customization. The user can write to this area once, after which it is automatically and permanently locked. After it is locked, the OTP area becomes read only, just like a ROM device.

Typically, the OTP area is used to store customer and product information such as: product ID, software version, production data, customer ID and tracking information.

3.4.4 One-Time Write (ROM-Like) Partition

A single partition in the Mobile DiskOnChip P3 can be set as One-Time Write. After it is locked, this partition becomes read only, just like a ROM device. Its capacity is defined during the media-formatting stage.

3.4.5 Sticky Lock (SLOCK)

The boot partition can be locked automatically by hardware after the boot phase is completed and the device is in Normal mode. This is done by setting the Sticky Lock (SLOCK) bit in the Output Control register to 1. This has the same effect as asserting the LOCK# signal. Once set, SLOCK can only be cleared by asserting the RSTIN# input. Like the LOCK# input, assertion of this bit prevents the protection key from disabling the protection for a given partition. There is no need to mount the boot partition before calling a hardware protection routine.

Upon reset, the boot partition is unlocked for the duration of the boot phase, and is automatically locked once this phase is over. This provides a high level of protection to the boot code, while still enabling an easy method for field and remote upgrades.

3.5 Programmable Boot Block with eXecute In Place (XIP) Functionality

The Programmable Boot Block with XIP functionality enables Mobile DiskOnChip P3 to act as a boot device in addition to performing flash disk data storage functions. This eliminates the need for expensive, legacy NOR flash or any other boot device on the motherboard.

The Programmable Boot Block on Mobile DiskOnChip P3 256Mb is 2KB in size. The Download Engine (DE), described in the next section, expands the functionality of this block by copying the boot code from the flash into the boot block.

DiskOnChip P3 256Mb devices may be cascaded in order to form a larger flash disk. When Mobile DiskOnChip P3 256Mb is connected with a standard NOR-like interface, up to four devices may be cascaded to create a 1Gb flash disk. When Mobile DiskOnChip P3 256Mb is connected with a multiplexed interface, up to two devices may be cascaded to create a 512 Mb flash disk.

Note: When more than one Mobile DiskOnChip P3 256Mb are cascaded, a maximum boot block of 4KB is available. The Programmable Boot Block of each device is mapped to a unique address space.

3.6 Download Engine (DE)

Upon power-up or when the RSTIN# signal is asserted, the DE automatically downloads the Initial Program Loader (IPL) to the Programmable Boot Block. The IPL is responsible for starting the booting process. The download process is quick, and is designed so that when the CPU accesses Mobile DiskOnChip P3 for code execution, the IPL code is already located in the Programmable Boot Block.

In addition, the DE downloads the data protection rules from the flash to the Protection State Machines (PSM), so that Mobile DiskOnChip P3 is secure and protected from the first moment it is active.

During the download process, Mobile DiskOnChip P3 asserts the BUSY# signal to indicate to the system that it is not yet ready to be accessed. Once BUSY# is negated, the system can access Mobile DiskOnChip P3.

A failsafe mechanism prevents improper initialization due to a faulty VCC or invalid assertion of the RSTIN# input. Another failsafe mechanism is designed to overcome possible NAND flash data errors. It prevents internal registers from powering up in a state that bypasses the intended data protection. In addition, any attempt to sabotage the data structures causes the entire DiskOnChip to become both read and write protected, and completely inaccessible.

3.7 Error Detection Code/Error Correction Code (EDC/ECC)

M-Systems' x2 technology implements 4-bit Error Detection Code/Error Correction Code (EDC/ECC), based on a patented combination of Bose, Chaudhuri and Hocquenghem (BCH) and Hamming code algorithms. Error Detection Code (EDC) is implemented in hardware to optimize performance, while Error Correction Code (ECC) is performed in software, when required, to save silicon costs.

Each time a 256-byte page is written, additional parity bits are calculated and written to the flash. Each time data is read from the flash, the parity bits are read and used to calculate error locations.

The Hamming code can detect 2 errors per page and correct 1 error per page. The BCH code can detect and correct 4 errors per page. It can detect 5 errors per page with a probability of 99.9%. It ensures that the minimal amount of code required is used for detection and correction to deliver the required reliability without degrading performance.

3.8 Data Pipeline

Mobile DiskOnChip P3 uses a two-stage pipeline mechanism, designed for maximum performance while enabling on-the-fly data manipulation, such as read/write protection and Error Detection/Error Correction. Refer to technical note TN-DOC-014, *Pipeline Mechanism in DiskOnChip*, for further information.

3.9 Control and Status

The Control and Status block contains registers responsible for transferring address, data and control information between the DiskOnChip TrueFFS driver and the flash media. Additional registers are used to monitor the status of the flash media (ready/busy) and the DiskOnChip controller. For further information on the DiskOnChip registers, refer to Section 8.

3.10 Flash Architecture

Mobile DiskOnChip P3 256Mb consists of two 128Mb flash planes that consist of 1024 blocks each, divided in groups of 32 pages, as follows:

- **Page** – Each page contains 512 bytes of user data and a 8-byte extra area that is used to store flash management and EDC/ECC signature data, as shown in Figure 8.
- **Block** – Each block contains 32 pages (total of 128Kb), as shown in Figure 9. A block is the minimal unit that can be erased, and is sometimes referred to as an erase block.

Note: Since the device works with multiple planes, the operational block size is 256Kb, as described in the next section.

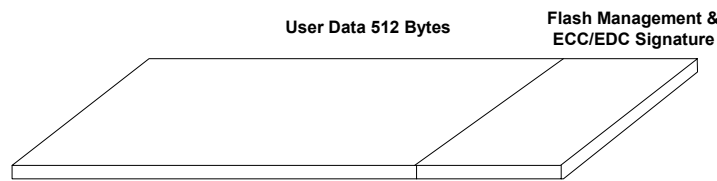

Figure 8: Page Structure

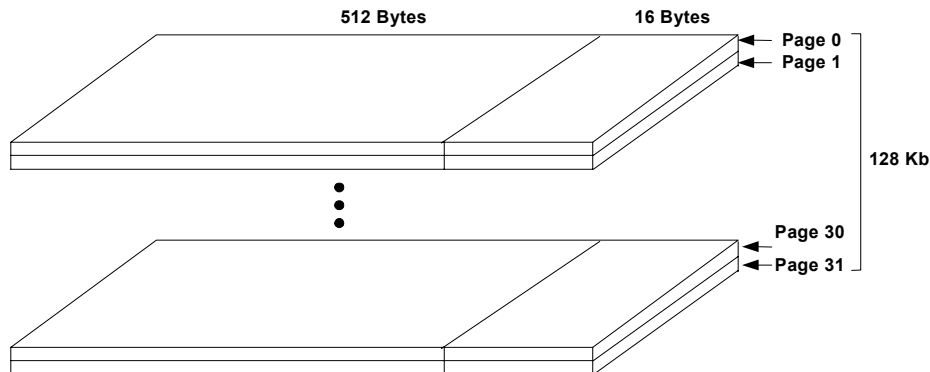

Figure 9: Block Structure

Parallel Multi-Plane Access

The two 128Mb flash planes operate in parallel, thereby providing a true 32-bit internal data bus and four times the read, write and erase performance. Two pages on different planes can be concurrently read or written if they have the same offset within their respective units, even if the units are unaligned.

Bad units are mapped individually on each plane by enabling unaligned unit access, as shown in Figure 10. Good units can therefore be aligned or unaligned, minimizing the effects of bad units on the media. Without this capability, a bad unit in one plane would cause a good unit in the second plane to be tagged as a bad unit, making it unusable. This customized method of bad unit handling for two planes enhances data reliability without adversely affecting performance.

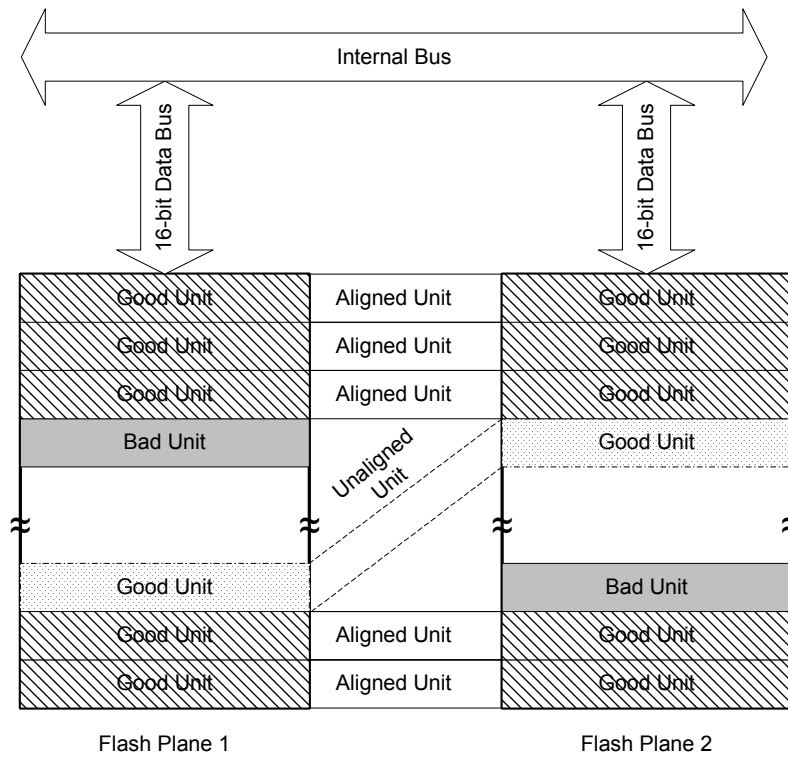

Figure 10: Unaligned Multi-Plane Access

4. X2 TECHNOLOGY

Mobile DiskOnChip P3 enhances performance using various proprietary techniques:

- Parallel access to the separate 128Mb flash planes, thereby providing an internal 32-bit data bus. See Section 3.10 for further information.
- MultiBurst operation to read large chunks of data, providing a MultiBurst read speed of up to 80 MB/sec.
- DMA operation to release the CPU for other tasks in coordination with the platform's DMA controller. This is especially useful during the boot stage. Up to 32KB of data can be transferred during a DMA operation.
- Turbo operation to enhance read access time from 55 ns to 33 ns (standard interface, access to flash addresses).

4.1 MultiBurst Operation

MultiBurst operation is especially effective for large file reads that are typical during boot-up. During MultiBurst operation, data is read from the two flash planes in parallel through a 32-bit wide internal flash interface. Data is read by the host one 16-bit word after another using the CLK input, resulting in a MultiBurst read mode of up to 80 MB/sec. MultiBurst operation can only be performed on hosts that support burst reads. See Figure 11 below.

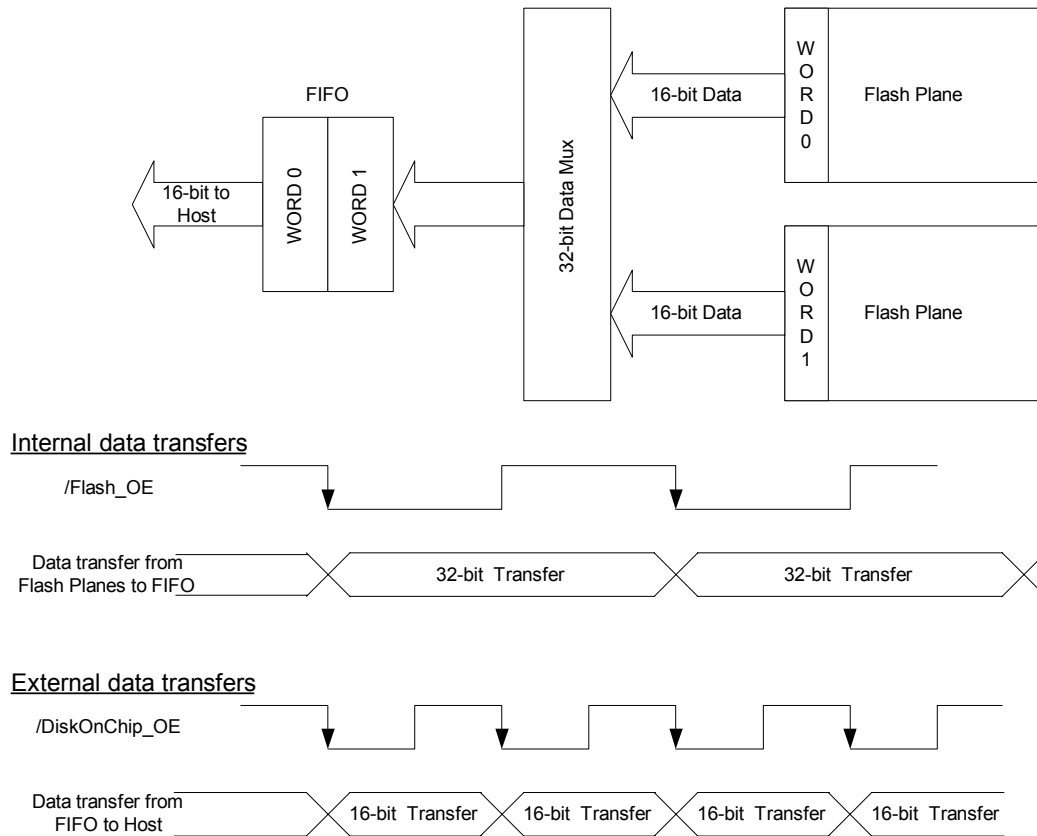

Figure 11: MultiBurst Operation

Note: Mobile DiskOnChip P3 does not support MultiBurst write operations.

MultiBurst operation is controlled by 5 bits in the MultiBurst Mode Control register: BURST_EN, CLK_INV, LATENCY, HOLD and LENGTH. For full details on this register, please refer to Section 8.

MultiBurst mode read cycles are supported via the CLK input, which is enabled by setting the BURST_EN bit in the MultiBurst Mode Control register.

To determine whether the rising or falling edge of the CLK input is sampled (called CLK0), the CLK_INV bit in the MultiBurst Mode Control register must be specified. When the CLK_INV bit is set to 0, CE# and OE# are sampled on the rising edge of CLK; when the CLK_INV bit is set to 1, sampling is done on the falling edge of CLK.

- Notes:
1. When the CLK_INV bit is set to 1, sampling is done on the falling edge of CLK, and an additional half-clock cycle of latency is incurred. Data continues to be output on D[15:0] on the rising edge of CLK.
 2. The CLK input is disabled upon the assertion of the RSTIN# input and may therefore be left floating.

The LATENCY bit is the third bit that must be set in the MultiBurst Mode Control register. When the LATENCY bit is set to 0, the host can latch the first 16-bit data word two clock cycles after CLK0. This time can be extended by up to seven clock cycles by programming the LATENCY bit. After latching the first word, additional 16-bit data words can be latched on each subsequent clock cycle.

The HOLD bit in the MultiBurst Mode Control register can be set to hold each data word valid for two clock cycles rather than one.

The LENGTH bit in the MultiBurst Mode Control register must be programmed with the length of the burst to be performed. As read cycles from the flash are volatile, each burst cycle must read exactly this number of words.

The CLK input can be toggled continuously or can be halted. When halting the CLK input, the following guidelines must be observed:

- After asserting OE# and CE#, LATENCY + 2 CLK cycles are required prior to latching the first word (2.5 CLK cycles if CLK_INV is set to 1).
- If the HOLD bit is set to 0, the host must provide one rising CLK edge for each word read, except for the last word latched, for which CLK does not need to be toggled.
- If the HOLD bit is set to 1, the host must provide two rising CLK edges for each word read, except for the last word, for which the second of the two CLK rising edges is not required.
- Subsequent toggling of the CLK is optional.

4.2 DMA Operation

Mobile DiskOnChip P3 provides a DMARQ# output that enables up to 32KB to be read from the flash by the host DMA controller. During DMA operation, the DMARQ# output is used to notify the host DMA controller that the next flash page is ready to be read, and the IRQ# pin indicates whether an error occurred while reading the data from the flash or the end of the DMA transfer was reached.

The DMARQ# output sensitivity is chosen by setting the EDGE bit in the DMA Control register[0]:

- **Edge** – The DMARQ# output pulses to logic 0 for 250~500 nsec to indicate to the DMA controller that a flash page is ready to be read. The EDGE bit is set to 1 for this mode.
- **Level** – The DMARQ# output is asserted to initiate the block transfer and returns to the negated state at the end of each block transfer. The EDGE bit is set to 0 for this mode.

The following steps are required to initiate a DMA operation:

1. Initialize the platform's DMA controller to transfer 512 bytes upon each assertion of the DMARQ# output. If the DMA controller supports an edge-sensitive DMARQ# signal, then initialize the DMA controller to transfer 512 bytes upon each DMA request. If the DMA controller supports a level-sensitive DMARQ# signal, then initialize the DMA controller to transfer data while DMARQ# is asserted.

2. Set the bits in the Interrupt Control register (see Section 8) to enable interrupts on an ECC error and at the end of the DMA operation.
3. Write to the DMA Control register[0] to set the DMA_EN bit, the EDGE bit and the number of sectors (SECTOR_COUNT bit) to be transferred to the host. At this point, Mobile DiskOnChip P3 generates a DMA request to indicate to the host that it is ready to transfer data.
4. The host DMA controller reads one sector (512 bytes) of data from Mobile DiskOnChip P3.
5. If an ECC error is detected, an interrupt is generated (IRQ# signal asserted), the transfer of data is halted and control is returned to the host. If no ECC error is detected, a DMA request is initiated (DMARQ# signal asserted) and the next sector is read by the host.
6. The process continues until the last sector is read, after which Mobile DiskOnChip P3 generates an interrupt (IRQ# signal asserted) to indicate that it has transferred the last byte.

- Notes:
1. Mobile DiskOnChip P3 generates a DMA request (DMARQ# signal asserted) after the last byte is read. It may therefore be necessary to clear the final DMA request from the DMA controller.
 2. DMA operation may be aborted after transferring each 512-byte block (step 4) by clearing the DMA_EN bit in the DMA Control register[0].

4.3 Combined MultiBurst Mode and DMA Operation

When using MultiBurst mode and DMA operation together, and an interrupt is generated (IRQ# signal asserted), the Download Status register cannot be polled, as it will not comply with the MultiBurst mode timing specification. The following sequence is therefore required to respond to an interrupt request while in MultiBurst mode:

- Perform 7 write cycles to the NOP register.
- Turn off MultiBurst mode by writing to the MultiBurst Mode Control register.

4.4 Turbo Operation

In order to provide faster read access time, Mobile DiskOnChip P3 can be configured for Turbo operation by enabling the D[15:0] output buffers immediately after the assertion of OE# and CE#.

Enter Turbo operation by setting the TURBO bit in the Output Control register. For timing specifications for Turbo operation, see Section 11.3.

Since the read access time for the Programmable Boot Block is slower than the read access time for the registers, bus contention may occur when reading from the Programmable Boot Block during system boot. It is therefore not recommended to use Turbo operation during boot, but only after the system is up and running and Mobile DiskOnChip P3 is being used as a flash disk.

5. HARDWARE PROTECTION

5.1 Method of Operation

Mobile DiskOnChip P3 enables the user to define two partitions that are protected (in hardware) against any combination of read or write operations. The two protected areas can be configured as read protected or write protected, and are protected by a protection key (i.e. password) defined by the user. Each of the protected areas can be configured separately and can function separately, providing maximum flexibility for the user.

The size and protection attributes (protection key, read, write, changeable, lock) of the protected partition are defined in the media formatting stage (DFORMAT utility or the format function in the TrueFFS SDK).

In order to set or remove read/write protection, the protection key (i.e., password) must be used, as follows:

- Insert the protection key to remove read/write protection.
- Remove the protection key to set read/write protection.

Mobile DiskOnChip P3 has an additional hardware safety measure. If the Lock option is enabled (by means of software) and the LOCK# signal is asserted, the protected partition has an additional hardware lock that prevents read/write access to the partition, even with the use of the correct protection key. The LOCK# signal must be asserted during DFORMAT (and later when the partition is defined as changeable) to enable the additional hard-wired safety lock.

It is possible to set the Lock option for one session only; that is, until the next power-up or reset. This Sticky Lock feature can be useful when the boot code in the boot partition must be read/write protected. Upon power-up, the boot code must be unprotected so the CPU can run it directly from Mobile DiskOnChip P3. At the end of the boot process, protection can be set until the next power-up or reset.

Setting the Sticky Lock (SLOCK) bit in the Output Control register to 1 has the same effect as asserting the LOCK# signal. Once set, SLOCK can only be cleared by asserting the RSTIN# input. Like the LOCK# input, the assertion of this bit prevents the protection key from disabling the protection for a given partition. For more information, see Section 3.4.5. The target partition does require mounting before calling a hardware protection routine.

The only way to read or write from a protected partition is to use insert the key (even DFORMAT does not remove the protection). This is also true for modifying its attributes (protection key, read, write and lock). Read/write protection is disabled in each of the following events:

- Power-down
- Change of any protection attribute (not necessarily in the same partition)
- Write operation to the IPL area
- Removal of the protection key.

For further information on hardware protection, please refer to the *TrueFFS Software Development Kit (SDK)* developer guide.

5.2 Low-Level Structure of the Protected Area

The first five blocks in Mobile DiskOnChip P3 contain foundry information, the Data Protect structures, IPL code, and bad block mapping information. See Figure 12.

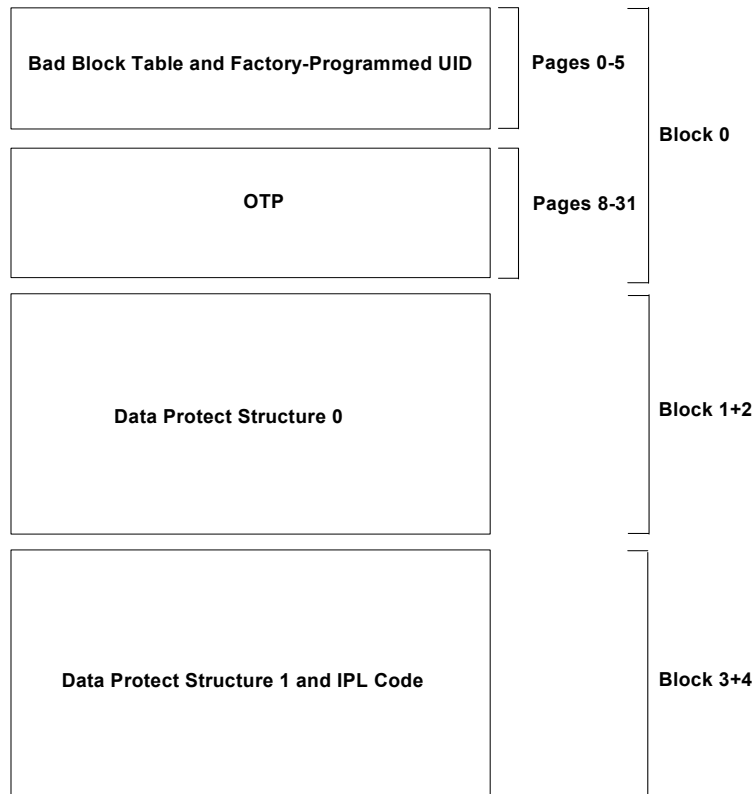

Figure 12: Low Level Structure of Mobile DiskOnChip P3

Blocks 0-4 in Mobile DiskOnChip P3 contain the following information:

Block 0

- o Bad Block Table (page 4). Contains the mapping information on unusable erase units on the flash media.
- o UID (16 bytes). This number is written during the manufacturing stage, and cannot be altered at a later time.
- o Customer OTP (occupies pages 8-31). The OTP area is written once and then locked.

Block 1 and 2

- o Data Protect Structure 0. This structure contains configuration information on one of the two user-defined protected partitions. Block 2 is a copy of Block 1 for redundancy purposes.

Block 3 and 4

- o Data Protect Structure 1. This structure contains configuration information on one of the two user-defined protected partitions.
- o IPL Code (2KB). This is the boot code that is downloaded by the DE to the internal boot block.
- o Block 4 is a copy of Block 3 for redundancy purposes.

6. MODES OF OPERATION

Mobile DiskOnChip P3 operates in one of three basic modes:

- Normal mode
- Reset mode
- Deep Power-Down mode

The current mode of the chip can always be determined by reading the DiskOnChip Control register. Mode changes can occur due to any of the following events:

- Assertion of the RSTIN# signal sets the device in Reset mode.
- During power-up, boot detector circuitry sets the device in Reset mode.
- A valid write sequence to Mobile DiskOnChip P3 sets the device in Normal mode. This is done automatically by the TrueFFS driver on power-up (reset sequence end).
- Switching back from Normal mode to Reset mode can be done by a valid write sequence to Mobile DiskOnChip P3, or by triggering the boot detector circuitry (via a soft reset).
- Deep Power-Down
- A valid write sequence, initiated by software, sets the device from Normal mode to Deep Power-Down mode. Four read cycles from offset 0x1FFF set the device back to Normal mode. Alternately, the device can be set back to Normal mode with an extended access time during a read from the Programmable Boot Block.
- Asserting the RSTIN# signal and holding it in this state while in Normal mode puts the device in Deep Power-Down mode. When RSTIN# is released, the device is set in Reset mode.
- Toggling the DPD signal as defined by the DPD Control register.

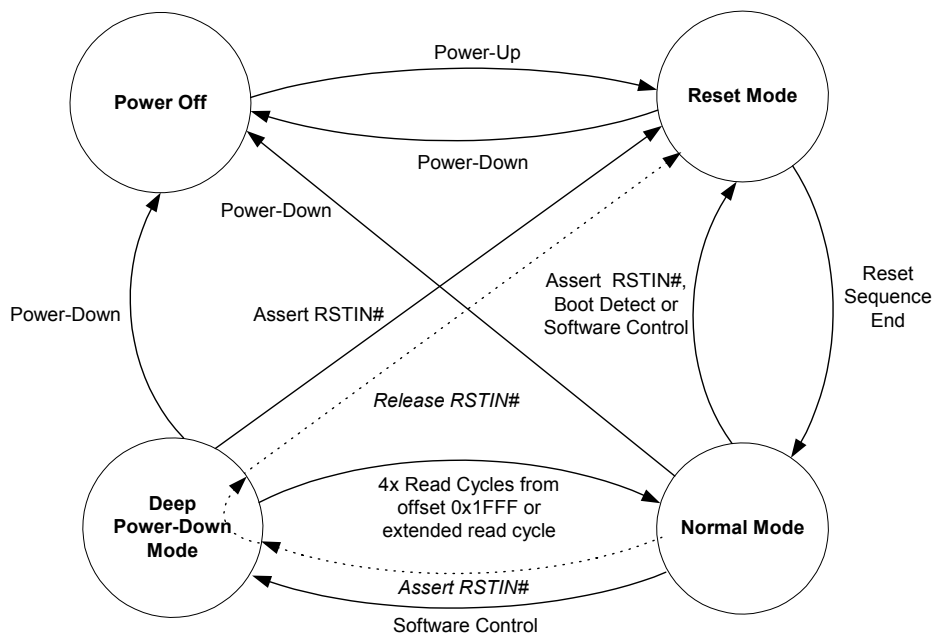

Figure 13: Operation Modes and Related Events

6.1 Normal Mode

This is the mode in which standard operations involving the flash memory are performed. Normal mode is entered when a valid write sequence is sent to the DiskOnChip Control register and Control Confirmation register. The boot detector circuit triggers the software to set the device to Normal mode.

A write cycle occurs when both the CE# and WE# inputs are asserted. Similarly, a read cycle occurs when both the CE# and OE# inputs are asserted. Because the flash controller generates its internal clock from these CPU cycles and some read operations return volatile data, it is essential that the timing requirements specified in Section 11.3 be met. It is also essential that read and write cycles not be interrupted by glitches or ringing on the CE#, WE#, and OE# address inputs. All inputs to Mobile DiskOnChip P3 are Schmidt Trigger types to improve noise immunity.

6.2 Reset Mode

In Reset mode, Mobile DiskOnChip P3 ignores all write cycles, except for those to the DiskOnChip Control register and Control Confirmation register. All register read cycles return a value of 00H.

Before attempting to perform a register read operation, the device is set to Normal mode by TrueFFS software.

6.3 Deep Power-Down Mode

While in Deep Power-Down mode, Mobile DiskOnChip P3's quiescent power dissipation is reduced by disabling internal high current consumers (e.g. voltage regulators, input buffers, oscillator etc.). The following signals are also disabled in this mode:

- **Standard interface:** Input buffers A[12:0], WE#, D[15:0] and OE# (when CE# is negated)
- **Multiplexed interface:** Input buffers AD[15:0], AVD#, WE# and OE# (when CE# is negated).

To enter Deep Power-Down mode, a proper sequence must be written to the Mobile DiskOnChip P3 Control registers and the CE# input must be negated. All other inputs should be VSS or VCC.

When in Normal mode, asserting the RSTIN# signal and holding it in low state puts the device in Deep Power-Down mode. When the RSTIN# signal is released, the device is set in Reset mode.

In Deep Power-Down mode, write cycles have no effect and read cycles return indeterminate data (Mobile DiskOnChip P3 does not drive the data bus). Entering Deep Power-Down mode and then returning to the previous mode does not affect the value of any register.

To exit Deep Power-Down mode, use one of the following methods:

- Read four times from address 1FFFH (Programmable Boot Block). The data returned is undefined.
- Perform a single read cycle from the Programmable Boot Block with an extended access time and address hold time as specified in the timing diagrams. The data returned will be correct. Please note that this option can only be used with a standard interface, not with a multiplexed interface.
- Toggle the DPD input as defined by the DPD Control register.

Applications that use Mobile DiskOnChip P3 as a boot device must ensure that the device is not in Deep Power-Down mode before reading the Boot vector/instructions. This can be done by pulsing RSTIN# to the asserted state and waiting for the BUSY# output to be negated, or by entering Reset mode via software (the Programmable Boot Block addresses can be accessed in Deep Power-Down mode).

7. TRUEFFS TECHNOLOGY

7.1 General Description

M-Systems' patented TrueFFS technology was designed to maximize the benefits of flash memory while overcoming inherent flash limitations that would otherwise reduce its performance, reliability and lifetime. TrueFFS emulates a hard disk, making it completely transparent to the OS. In addition, since it operates under the OS file system layer (see Figure 14), it is completely transparent to the application.

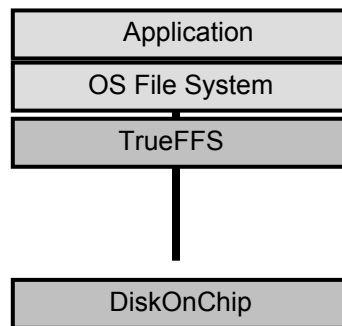

Figure 14: TrueFFS Location in System Hierarchy

TrueFFS technology support includes:

- Binary driver support for all major OSs
- TrueFFS Software Development Kit (TrueFFS SDK)
- Boot Software Development Kit (BDK)
- Support for all major CPUs, including 8, 16 and 32-bit bus architectures.

TrueFFS technology features:

- Block device API
- Flash file system management
- Bad-block management
- Dynamic virtual mapping
- Dynamic and static wear-leveling
- Power failure management
- Implementation of EDC/ECC
- Performance optimization
- Compatibility with all DiskOnChip products

7.1.1 Built-In Operating System Support

The TrueFFS driver is integrated into all major OSs, including Symbian, Palm OS, Pocket PC 2002/3, Smartphone 2002/3, Windows CE/NT, Linux (various kernels), Nucleus, and others. For a complete listing of all available drivers, please refer to M-Systems' website, www.m-sys.com. It is advised to use the latest driver versions that can be downloaded from the website.

7.1.2 TrueFFS Software Development Kit (SDK)

The basic *TrueFFS Software Development Kit (SDK)* developer guide provides the source code for the TrueFFS driver. It can be used in an OS-less environment or when special customization of the driver is required for proprietary OSs.

When using Mobile DiskOnChip P3 as the boot replacement device, TrueFFS SDK also incorporates in its source code the boot software that is required for this configuration (this package is also available separately). Please refer to the *DiskOnChip Boot Software Development Kit (BDK)* developer guide for further information on using this software package.

Note: Mobile DiskOnChip P3 is supported by TrueFFS 6.1 and above.

7.1.3 File Management

TrueFFS accesses the flash memory within Mobile DiskOnChip P3 through an 8KB window in the CPU memory space. TrueFFS provides block device API by using standard file system calls, identical to those used by a mechanical hard disk, to enable reading from and writing to any sector on Mobile DiskOnChip P3. This makes Mobile DiskOnChip P3 compatible with any file system and file system utilities, such as diagnostic tools and applications. When using the Flash Allocation Table (FAT) file system, the data stored on Mobile DiskOnChip P3 uses the FAT-16 file system.

Note: Mobile DiskOnChip P3 is shipped unformatted and contains virgin media.

7.1.4 Bad Block Management

Since NAND flash is an imperfect storage media, it can contain bad blocks that cannot be used for storage because of their high error rates. TrueFFS automatically detects and maps out bad blocks upon system initialization, ensuring that they are not used for storage. This management process is completely transparent to the user, who is unaware of the existence and location of bad blocks, while remaining confident of the integrity of data stored.

7.1.5 Wear-Leveling

Flash memory can be erased a limited number of times. This number is called the *erase cycle limit*, or *write endurance limit*, and is defined by the flash array vendor. The erase cycle limit applies to each individual erase block in the flash device. In Mobile DiskOnChip P3, the erase cycle limit of the flash is 100,000 erase cycles. This means that after approximately 100,000 erase cycles, the erase block begins to make storage errors at a rate significantly higher than the error rate that is typical to the flash.

In a typical application, and especially if a file system is used, specific pages are constantly updated (e.g., the page/s that contain the FAT, registry, etc.). Without any special handling, these pages would wear out more rapidly than other pages, reducing the lifetime of the entire flash.

To overcome this inherent deficiency, TrueFFS uses M-Systems' patented wear-leveling algorithm. This wear-leveling algorithm ensures that consecutive writes of a specific sector are not written physically to the same page in the flash. This spreads flash media usage evenly across all pages, thereby maximizing flash lifetime. TrueFFS wear-leveling extends the flash lifetime 10 to 15 years beyond the lifetime of a typical application.

Dynamic Wear-Leveling

TrueFFS uses statistical allocation to perform dynamic wear-leveling on newly written data. This not only minimizes the number of erase cycles per block, it also minimizes the total number of erase cycles. Because a block erase is the most time-consuming operation, dynamic wear-leveling has a major impact on overall performance. This impact cannot be noticed during the first write to flash (since there is no need to erase blocks beforehand), but it is more and more noticeable as the flash media becomes full.

Static Wear-Leveling

Areas on the flash media may contain static files, characterized by blocks of data that remain unchanged for very long periods of time, or even for the whole device lifetime. If wear-leveling were only applied on newly written pages, static areas would never be cycled. This limited application of wear-leveling would lower life expectancy significantly in cases where flash memory contains large static areas. To overcome this problem, TrueFFS forces data transfer in static areas as well as in dynamic areas, thereby applying wear-leveling to the entire media.

7.1.6 Power Failure Management

TrueFFS uses algorithms based on "erase after write" instead of "erase before write" to ensure data integrity during normal operation and in the event of a power failure. Used areas are reclaimed for erasing and writing the flash management information into them only *after* an operation is complete. This procedure serves as a check on data integrity.

The "erase after write" algorithm is also used to update and store mapping information on the flash memory. This keeps the mapping information coherent even during power failures. The only mapping information held in RAM is a table pointing to the location of the actual mapping information. This table is reconstructed during power-up or after reset from the information stored in the flash memory.

To prevent data from being lost or corrupted, TrueFFS uses the following mechanisms:

- When writing, copying, or erasing the flash device, the data format remains valid at all intermediate stages. Previous data is never erased until the operation has been completed and the new data has been verified.
- A data sector cannot exist in a partially written state. Either the operation is successfully completed, in which case the new sector contents are valid, or the operation has not yet been completed or has failed, in which case the old sector contents remain valid.

7.1.7 Error Detection/Correction

TrueFFS implements a unique Error Correction Code (ECC) algorithm to ensure data reliability. Refer to Section 3.7 for further information on the EDC/ECC mechanism.

7.1.8 Special Features Through I/O Control (IOCTL) Mechanism

In addition to standard storage device functionality, the TrueFFS driver provides extended functionality. This functionality goes beyond simple data storage capabilities to include features such as: formatting the media, read/write protection, boot partition(s) access, flash defragmentation and other options. This unique functionality is available in all TrueFFS-based drivers through the standard I/O control command of the native file system.

7.1.9 Compatibility

Mobile DiskOnChip P3 requires TrueFFS driver 6.x or higher.

When using different drivers (e.g. TrueFFS SDK, BDK, BIOS extension firmware, etc.) to access Mobile DiskOnChip P3, verify that all software is based on the same code base version. It is also important to use only tools (e.g. DFORMAT, DINFO, GETIMAGE, etc.) from the same version as the firmware and the TrueFFS drivers used in the application. Failure to do so may lead to unexpected results, such as lost or corrupted data. The driver and firmware version can be verified by the sign-on messages displayed, or by the version information stored in the driver or tool.

7.2 8KB Memory Window

TrueFFS utilizes an 8KB memory window in the CPU address space, consisting of four 2KB sections as depicted in Figure 15. When in Reset mode, read cycles from sections 1 and 2 always return the value 00H to create a fixed and known checksum. When in Normal mode, these two sections are used for the internal registers. The 2KB Programmable Boot Block is in section 0 and section 3, to support systems that search for a checksum at the boot stage both from the top and bottom of memory. The addresses described here are relative to the absolute starting address of the 8KB memory window.

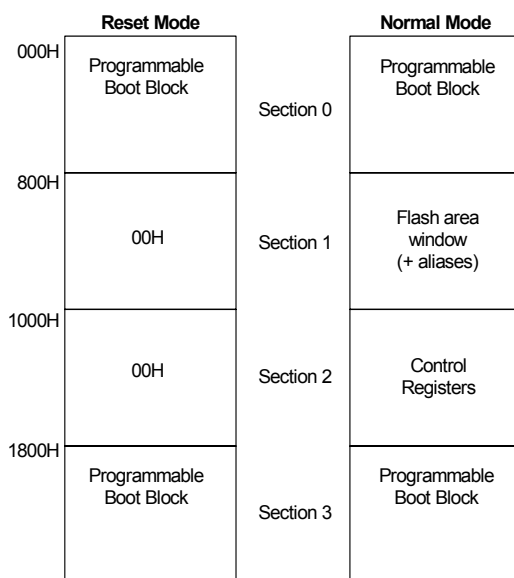

Figure 15: Mobile DiskOnChip P3 Memory Map

8. REGISTER DESCRIPTIONS

This section describes various Mobile DiskOnChip P3 registers and their functions, as listed in Table 5. Most Mobile DiskOnChip P3 registers are 8-bit, unless otherwise denoted as 16-bit.

Table 5: Mobile DiskOnChip P3 Registers

Address (Hex)	Register Name
103E	No Operation (NOP)
1000/1074	Chip Identification [1:0]
1004	Test
1006	Bus Lock
1008	Endian Control
100C	DiskOnChip Control
1072	DiskOnChip Control Confirmation
100A	Device ID Select
100E	Configuration
1010	Interrupt Control
1020	Interrupt Status
1014	Output Control
107C	DPD Control
1078/107A	DMA Control [1:0]
101C	MultiBurst Mode Control

8.1 Definition of Terms

The following abbreviations and terms are used within this section:

- RFU Reserved for future use. This bit is undefined during a read cycle and “don’t care” during a write cycle.
- RFU_0 Reserved for future use; when read, this bit always returns the value 0; when written, software should ensure that this bit is always set to 0.
- RFU_1 Reserved for future use; when read, this bit always returns the value 1; when written, software should ensure that this bit is always set to 1.
- Reset Value Refers to the value immediately present after exiting from Reset mode to Normal mode.

8.2 Reset Values

All registers return 00H while in Reset mode. The Reset value written in the register description is the register value after exiting Reset mode and entering Normal mode. Some register contents are undefined at that time (N/A).

8.3 No Operation (NOP) Register

Description: A call to this 16-bit register results in no operation. To aid in code readability and documentation, software should access this register when performing cycles intended to create a time delay.

Address (hex): 103E

Type: Write

Reset Value: None

8.4 Chip Identification (ID) Register [0:1]

Description: These two 16-bit registers are used to identify the DiskOnChip device residing on the host platform. They always return the same value.

Address (hex): 1000/1074

Type: Read only

Reset Value: Chip Identification Register[0]: 0200H
 Chip Identification Register[1]: FDFFH

8.5 Test Register

Description: This register enables software to identify multiple Mobile DiskOnChip P3 devices or multiple aliases in the CPU's memory space. Data written is stored but does not affect the behavior of Mobile DiskOnChip P3.

Address (hex): 1004

Type: Read/Write

Reset Value: 0

Bit No.	Description
7-0	D[7:0]: Data bits

8.6 Bus Lock Register

Description: This register provides a mechanism for a CPU to request and hold sole access rights to Mobile DiskOnChip P3 in multiprocessor applications.

The following algorithm must be implemented to ensure that only one CPU at a time accesses Mobile DiskOnChip P3:

1. Before beginning an indivisible operation sequence (e.g. reading/writing a sector to the DiskOnChip), the value of this register is read. If it is non-zero, then it must continue to be polled until it becomes zero.
2. Once the value read is zero, a non-zero value unique to each CPU is written to this register to indicate to other CPUs that the device is in use.
3. The value written must then be confirmed. If the register returns the same value that was written, then the CPU is assured of sole access rights to Mobile DiskOnChip P3. If it is not the same value, then another CPU has claimed access rights to the device and the process must be repeated from step 1.
4. Upon completion of the indivisible operation sequence, this register must be set to 00H to release the lock and permit other CPUs to access the device.

Address (hex): 1006

Type: Read/Write

Reset Value: 0

Bit No.	Description
7-0	D[7:0]: CPU Control value

8.7 Endian Control Register

Description: This 16-bit register is used to control the swapping of the low and high data bytes when reading or writing with a 16-bit host. This provides an Endian-independent method of enabling/disabling the byte swap feature.

Note: Hosts that support 8-bit access only do not need to write to this register.

Address (hex): 1008

	Bit 7	Bit 6	Bit 5	Bit 4	Bit 3	Bit 2	Bit 1	Bit 0
Read/Write	R							R/W
Description	RFU_0							SWAPL
Reset Value	0	0	0	0	0	0	0	0

	Bit 15	Bit 14	Bit 13	Bit 12	Bit 11	Bit 10	Bit 9	Bit 8
Read/Write	R							R/W
Description	RFU_0							SWAPH
Reset Value	0	0	0	0	0	0	0	0

Bit No.	Description
0	SWAPL (Swap Low Byte): This bit must be set to enable byte swapping. If the bit is cleared, then byte swapping is disabled.
7-1	Reserved for future use.
8	SWAPH (Swap High Byte): This bit must be set to enable byte swapping. If the bit is cleared, then byte swapping is disabled.
15-9	Reserved for future use.

8.8 DiskOnChip Control Register/Control Confirmation Register

Description: These two registers are identical and contain information about the Mobile DiskOnChip P3 operational mode. After writing the required value to the DiskOnChip Control register, the complement of that data byte must also be written to the Control Confirmation register. The two writes cycles must not be separated by any other read or write cycles to the Mobile DiskOnChip P3 memory space, except for reads from the Programmable Boot Block space.

Address (hex): 100C/1072

	Bit 7	Bit 6	Bit 5	Bit 4	Bit 3	Bit 2	Bit 1	Bit 0
Read/Write	R/W					R		
Description	Mode[1:0]		MDWREN	BDET	RST_LAT	RFU_0		
Reset Value	0	0	0	0	1	0	0	0

Note: The DiskOnChip Control Confirmation register is write only

Bit No.	Description
1-0	Mode. These bits select the mode of operation, as follows: 00: Reset 01: Normal 10: Deep Power-Down
2	MDWREN (Mode Write Enable). This bit must be set to 1 before changing the mode of operation. It always returns 0 when read.
3	BDET (Boot Detect). This bit is set whenever the device has entered Reset mode as a result of the Boot Detector triggering. It is cleared by writing a 1 to this bit.
4	RST_LAT (Reset Latch). This bit is set whenever the device has entered the Reset mode as a result of the RSTIN# input signal being asserted or the internal voltage detector triggering. It is cleared by writing a 1 to this bit.
7-5	Reserved for future use.

8.9 Device ID Select Register

Description: In a cascaded configuration, this register controls which device provides the register space. The value of bits ID[0:1] is compared to the value of the ID configuration input pins/balls. The device whose ID input matches the value of bits ID[0:1] responds to read and write cycles.

Address (hex): 100A

	Bit 7	Bit 6	Bit 5	Bit 4	Bit 3	Bit 2	Bit 1	Bit 0
Read/Write	R						R/W	
Description	RFU_0						ID[1:0]	
Reset Value	0	0	0	0	0	0	0	0

Bit No.	Description
1-0	ID[1:0] (Identification). The device whose ID input pins/balls match the value of bits ID[0:1] responds to read and write cycles to register space.
7-2	Reserved for future use.

8.10 Configuration Register

Description: This register indicates the current configuration of Mobile DiskOnChip P3. Unless otherwise noted, the bits are reset only by a hardware reset, and not upon boot detection or any other entry to Reset mode.

Address (hex): 100E

	Bit 7	Bit 6	Bit 5	Bit 4	Bit 3	Bit 2	Bit 1	Bit 0
Read/Write	R		R/W		R			
Description	IF_CFG	RFU_0	MAX_ID		RFU	RFU_0		VCCQ_3V
Reset Value	X	0	0	0	0	0	0	X

Bit No.	Description
0	VCCQ_3V: Reflects the level of VCCQ input. 0: VCCQ < 2.0V 1: VCCQ > 2.5V
6, 3-1	Reserved for future use.
5-4	MAX_ID (Maximum Device ID). This field controls the Programmable Boot Block address mapping when multiple devices are used in a cascaded configuration, using the ID[1:0] inputs. It should be programmed to the highest ID value that is found by software in order to map all available boot blocks into usable address spaces.
7	IF_CFG (Interface Configuration). Reflects the state of the IF_CFG input pin.

8.11 Interrupt Control Register

Description: This 16-bit register controls how interrupts are generated by Mobile DiskOnChip P3, and indicates which of the following five sources has asserted an interrupt:

- 0: Flash array is ready
- 1: Data protection violation
- 2: Reading or writing more flash data than was specified in the DCNT field of ECC Control Register[0]
- 3: BCH ECC error detected (this feature is provided to support multi-page DMA transfers)
- 4: Real-time clock
- 5: Completion of a DMA operation

Address (hex): 1010

	Bit 7	Bit 6	Bit 5	Bit 4	Bit 3	Bit 2	Bit 1	Bit 0
Read/Write	R		R/W					
Description	RFU_0		ENABLE					
Reset Value	0	0	0	0	0	0	0	0

	Bit 15	Bit 14	Bit 13	Bit 12	Bit 11	Bit 10	Bit 9	Bit 8
Read/Write	R/W							
Description	GMASK	EDGE	MASK					
Reset Value	0	0	0	0	0	0	0	0

Bit No.	Description
5-0	ENABLE. For each bit in this field: 1: Enables the respective bit in the STATUS field of the Interrupt Status register to latch activity and cause an interrupt if the corresponding MASK bit is set. 0: Holds the respective bit in the STATUS field in the cleared state. To clear a pending interrupt and re-enable further interrupts on that channel, the respective ENABLE bit must be cleared and then set.
7-6	Reserved for future use.
13-8	MASK. For each bit in this field: 1: Enables the respective bit in the STATUS field of the Interrupt Status register to generate an interrupt by asserting the IRQ# output. 0: Prevents the respective STATUS bit from generating an interrupt.

Bit No.	Description
14	EDGE. Selects edge or level triggered interrupts: 0: Specifies level-sensitive interrupts in which the IRQ# output remains asserted until the interrupt is cleared. 1: Specifies edge-sensitive interrupts in which the IRQ# output pulses low and return to logic 1.
15	GMASK (Global Mask). 1: Enables the IRQ# output to be asserted. Setting this bit while one or more interrupts are pending will generate an interrupt. 0: Forces the IRQ# output to the negated state.

8.12 Interrupt Status Register

Description: This register indicates which interrupt source created an interrupt.

Address (hex): 1020

	Bit 7	Bit 6	Bit 5	Bit 4	Bit 3	Bit 2	Bit 1	Bit 0
Read/Write	R		R/W					
Description	RFU_0		STATUS					
Reset Value	0	0	0	0	0	0	0	0

Bit No.	Description
5-0	STATUS. Indicates which of the following interrupt sources created an interrupt: 0: Flash array is ready 1: Data protection violation 2: Reading or writing more flash data than was specified in the DCNT field of ECC Control register[0] 3: BCH ECC error detected (this feature is provided to support multi-page DMA transfers) 4: Real time clock 5: Completion of a DMA operation
7-6	Reserved for future use.

8.13 Output Control Register

Description: This register controls the behavior of certain output signals. This register is reset by a hardware reset, not by entering Reset mode.

Note: When multiple devices are cascaded, writing to this register will affect all devices regardless of the value of the ID[1:0] inputs.

Address (hex): 1014

	Bit 7	Bit 6	Bit 5	Bit 4	Bit 3	Bit 2	Bit 1	Bit 0
Read/Write	R					R/W		
Description	RFU_0					Turbo	PU_DIS	BUSY_EN
Reset Value	0	0	0	0	0	0	0	1

Bit No.	Description
0	<p>BUSY_EN (Busy Enable). Controls the assertion of the BUSY# output during a download initiated by a soft reset.</p> <p>1: Enables the assertion of the BUSY# output 0: Disables the assertion of the BUSY# output</p> <p>Upon the assertion of the RSTIN# input, this bit will be set automatically and the BUSY# output signal will be asserted until the completion of the download process.</p>
1	<p>PU_DIS (Pull-up Disable). Controls the pull-up resistors D[15:8] as follows:</p> <p>1: Always disable the pull-ups 0: Enable the pull-ups when IF_CFG = 0</p>
2	<p>TURBO. Activates turbo operation.</p> <p>0: DiskOnChip is used in normal operation, without improved access time. Output buffers are enabled only after a long enough delay to guarantee that there will be no more than a single transition on each bit.</p> <p>1. DiskOnChip is used in Turbo operation. Output buffers are enabled immediately after the assertion of OE# and CE#, resulting in improved access time. Read cycles from the Programmable Boot Block may result in additional noise and power dissipation due to multiple transitions on the data bus.</p>
7-3	Reserved for future use.

8.14 DPD Control Register

Description: This register specifies the behavior of the DPD input signal.

Address (hex): 107C

	Bit 7	Bit 6	Bit 5	Bit 4	Bit 3	Bit 2	Bit 1	Bit 0
Read/Write	R				R/W			
Description	PD_OK	RFU_0			MODE[0:3]			
Reset Value	0	0	0	0	0	0	0	0

Bit No.	Description
3-0	MODE[0:3]. Controls the behavior of the DPD input: 0000: DPD input is not used to control DPD mode 0001: DPD mode exited on rising edge of DPD input 0010: DPD mode exited on falling edge of DPD input 0100: DPD mode is entered when DPD=1 and exited when DPD=0 1000: DPD mode is entered when DPD=0 and exited when DPD=1
6-4	Reserved for future use.
7	PD_OK (Power- Down OK). This read-only bit indicates that it is currently possible to put Mobile DiskOnChip P3 in Deep Power-Down mode.

8.15 DMA Control Register [1:0]

Description: These two 16-bit registers specify the behavior of the DMA operation.

Address (hex): 1078/107A

	Bit 7	Bit 6	Bit 5	Bit 4	Bit 3	Bit 2	Bit 1	Bit 0
Read/Write	R	R/W						
Description	RFU_0	SECTOR_COUNT						
Reset Value	0	0	0	0	0	0	0	0

	Bit 15	Bit 14	Bit 13	Bit 12	Bit 11	Bit 10	Bit 9	Bit 8
Read/Write	R	R/W			R			
Description	DMA_EN	PAUSE	EDGE	POLRTY	RFU_0			
Reset Value	0	0	0	0	0	0	0	0

Bit No.	Description
6-0	SECTOR_COUNT. Specifies the number of 512-byte sectors to be transferred plus one. Writing a v (a value of 0) indicates a transfer of one sector. Reading a value of 0 indicates that there is still one sector to be transferred). This field is decremented by Mobile DiskOnChip P3 after reading the ECC checksum from each sector. In the event of an ECC error, this field indicates the number of sectors remaining to be transferred.
11-7	Reserved for future use.
12	POLRTY (Polarity). Specifies the polarity of the DMARQ# output: 0: DMARQ# is normally logic -1 and falls to initiate DMA 1: DMARQ# is normally logic -0 and rises to initiate DMA
13	EDGE. Controls the behavior of the DMARQ# output: 1: DMARQ# pulses to the asserted state for 250 nS (typical) to initiate the block transfer. 0: DMARQ# switches to the active state to initiate the block transfer and returns to the negated state at the beginning of the cycle in which the DCNT field of the ECC Control register[0] reaches the value specified by the NEGATE_COUNT field of the DMA Control register[1].
14	PAUSE. This bit is set in the event of an ECC error during a DMA operation. After reading the ECC parity registers and correcting the errors, the software must clear this bit to resume the DMA operation.
15	DMA_EN (DMA Enable). Setting this bit enables DMA operation.

DMA Control Register [1]							
	Bits 15-10				Bits 9-0		
Read/Write	R				R/W		
Description	RFU_0				NEGATE_COUNT		
Reset Value	0	0	0	0	0	0	0

Bit No.	Description
9-0	NEGATE_COUNT. When the EDGE bit of DMA Control register[0] is a 0, this bit must be programmed to specify the bus cycle in which DMARQ# will be negated as follows: $NEGATE_COUNT = BYTES_REMAINING + 16 + BYTES_PER_CYCLE$. Example: To negate DMARQ# at the beginning of the cycle in which the last word is to be transferred by a 16-bit host: $NEGATE_COUNT = 2 + 16 + 2 = 20$.
15-10	Reserved for future use.

8.16 MultiBurst Mode Control Register

Description: This 16-bit register controls the behavior of Mobile DiskOnChip P3 during MultiBurst mode read cycles.

Address (hex): 101C

	Bit 7	Bit 6	Bit 5	Bit 4	Bit 3	Bit 2	Bit 1	Bit 0
Read/Write	R					R/W		
Description	RFU_0					HOLD	CLK_INV	BST_EN
Reset Value	0	0	0	0	0	0	0	0

	Bit 15	Bit 14	Bit 13	12	Bit 11	Bit 10	Bit 9	Bit 8
Read/Write	R/W							
Description	LENGTH				LATENCY			
Reset Value	0	0	0	0	0	0	0	0

Bit No.	Description
0	BST_EN (MultiBurst Mode Enable). Enables MultiBurst mode read cycles. 0: The CLK input is disabled and may be left floating. Burst read cycles are not supported. 1: The CLK input is enabled. Subsequent read cycles must be MultiBurst mode.
1	CLK_INV (Clock Invert). Selects the edge of the CLK input on which CE# and OE# are sampled. 0: CE# and OE# are sampled on the rising edge of CLK. 1: CE# and OE# are sampled on the falling edge of CLK, and there will be an additional ½ clock delay from CE#/OE# asserted until the first data word may be latched on D[15:0].
2	HOLD. Specifies if the data output on D[15:0] during MultiBurst mode read cycles should be held for an additional clock cycle. 0: Data on the D[15:0] outputs is held for one clock cycle 1: Data on the D[15:0] outputs is held for two clock cycles
3-7	Reserved for future use.
8-11	LATENCY. Controls the number of clock cycles between when Mobile DiskOnChip P3 samples OE# and CE# asserted and the first word of data is available to be latched by the host. This number of clock cycles is equal to 2 + LATECNCY. If HOLD = 1, then the data is available to be latched on this clock and on the subsequent clock.
12-15	LENGTH. Specifies the number of byte/words (depending on IF_CFG) to be transferred in each burst cycle: HOLD=0: Number of bytes/words = 2 ^ LENGTH HOLD=1: Number of bytes/words = 2 ^ (LENGTH – 1) Note: The maximum value of LENGTH is 10.

9. BOOTING FROM MOBILE DISKONCHIP P3

9.1 Introduction

Mobile DiskOnChip P3 can function both as a flash disk and as the system boot device. Mobile DiskOnChip P3 default firmware contains drivers to enable it to perform as the OS boot device under DOS (see Section 9.2). For other OSs, please refer to the readme file of the TrueFFS driver.

If Mobile DiskOnChip P3 is configured as a flash disk and as the system boot device, it contains the boot loader, an OS image and a file system. In such a configuration, Mobile DiskOnChip P3 can serve as the only non-volatile device on board. Refer to Section 9.3.2 for further information on boot replacement.

9.2 Boot Procedure in PC-Compatible Platforms

When used in PC-compatible platforms, Mobile DiskOnChip P3 is connected to an 8KB memory window in the BIOS expansion memory range, typically located between 0C8000H to 0EFFFFH. During the boot process, the BIOS loads the TrueFFS firmware into the PC memory and installs Mobile DiskOnChip P3 as a disk drive in the system. When the operating system is loaded, Mobile DiskOnChip P3 is recognized as a standard disk. No external software is required to boot from Mobile DiskOnChip P3.

Figure 16 illustrates the location of the Mobile DiskOnChip P3 memory window in the PC memory map.

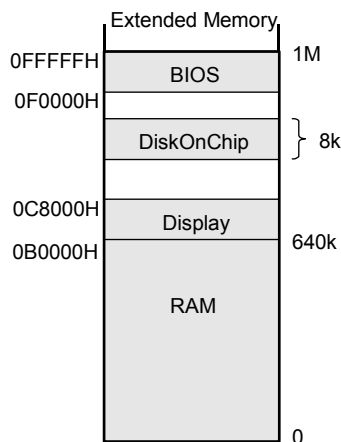

Figure 16: Mobile DiskOnChip P3 Memory Window in PC Memory Map

After reset, the BIOS code first executes the Power On Self-Test (POST) and then searches for all expansion ROM devices. When Mobile DiskOnChip P3 is located, the BIOS code executes from it the IPL code, located in the XIP portion of the Programmable Boot Block. This code loads the TrueFFS driver into system memory, installs Mobile DiskOnChip P3 as a disk in the system, and then returns control to the BIOS code. The operating system subsequently identifies Mobile DiskOnChip P3 as an available disk. TrueFFS responds by emulating a hard disk.

From this point onward, Mobile DiskOnChip P3 appears as a standard disk drive. It is assigned a drive letter and can be used by any application, without any modifications to either the BIOS set-up

or the `autoexec.bat/config.sys` files. Mobile DiskOnChip P3 can be used as the only disk in the system, with or without a floppy drive, and with or without hard disks.

The drive letter assigned depends on how Mobile DiskOnChip P3 is used in the system, as follows:

- If Mobile DiskOnChip P3 is used as the only disk in the system, the system boots directly from it and assigns it drive C.
- If Mobile DiskOnChip P3 is used with other disks in the system:
 - o Mobile DiskOnChip P3 can be configured as the last drive (the default configuration). The system assigns drive C to the hard disk and drive D to Mobile DiskOnChip P3.
 - o Alternatively, Mobile DiskOnChip P3 can be configured as the system's first drive. The system assigns drive D to the hard disk and drive C to Mobile DiskOnChip P3.

If Mobile DiskOnChip P3 is used as the OS boot device when configured as drive C, it must be formatted as a bootable device by copying the OS files onto it. This is done by using the `SYS` command when running DOS.

9.3 Boot Replacement

9.3.1 PC Architectures

In current PC architectures, the first CPU fetch (after reset is negated) is mapped to the boot device area, also known as the *reset vector*. The reset vector in PC architectures is located at address `FFFF0`, by using a Jump command to the beginning of the BIOS chip (usually `F0000` or `E0000`). The CPU executes the BIOS code, initializes the hardware and loads Mobile DiskOnChip P3 software using the BIOS expansion search routine (e.g. `D0000`). Refer to Section 9.2 for a detailed explanation on the boot sequence in PC-compatible platforms.

Mobile DiskOnChip P3 implements both disk and boot functions when it replaces the BIOS chip. To enable this, Mobile DiskOnChip P3 requires a location at two different addresses:

- After power-up, Mobile DiskOnChip P3 must be mapped in F segment, so that the CPU fetches the reset vector from address `FFFF0`, where Mobile DiskOnChip P3 is located.
- After the BIOS code is loaded into RAM and starts execution, Mobile DiskOnChip P3 must be reconfigured to be located in the BIOS expansion search area (e.g. `D0000`) so it can load the TrueFFS software.

This means that the `CS#` signal must be remapped between two different addresses. For further information on how to achieve this, refer to application note *AP-DOC-047, Designing DiskOnChip as a Flash Disk and Boot Device Replacement*.

9.3.2 Non-PC Architectures

In non-PC architectures, the boot code is executed from a boot ROM, and the drivers are usually loaded from the storage device.

When using Mobile DiskOnChip P3 as the system boot device, the CPU fetches the first instructions from the Mobile DiskOnChip P3 Programmable Boot Block, which contains the IPL. Since in most cases this block cannot hold the entire boot loader, the IPL runs minimum initialization, after which the Secondary Program Loader (SPL) is copied to RAM from flash. The remainder of the boot loader code then runs from RAM.

The IPL and SPL are located in a separate (binary) partition on Mobile DiskOnChip P3, and can be hardware protected if required. .

9.3.3 Asynchronous Boot Mode

Platforms that host CPUs that wake up in MultiBurst mode should use Asynchronous Boot mode when using Mobile DiskOnChip P3 as the system boot device.

During platform initialization, certain CPUs wake up in 32-bit mode and issue instruction fetch cycles continuously. An XScale CPU, for example, initiates a 16-bit read cycle, but after the first word is read, it continues to hold CE# and OE# asserted while it increments the address and reads additional data as a burst. A StrongARM CPU wakes up in 32-bit mode and issues double-word instruction fetch cycles.

Since Mobile DiskOnChip P3 derives its internal clock signal from the CE#, OE# and WE# inputs, it cannot distinguish between these burst cycles. To support this type of access, Mobile DiskOnChip P3 must be set in Asynchronous Boot mode by setting the RAM MODE SELECT byte to 8FH. This can be done through the Mobile DiskOnChip P3 format utility or by customizing the IPL code. For more information on the format utility, refer to the *DiskOnChip Software Utilities* user manual or the *TrueFFS Software Development Kit (SDK)* developer guide.

Once in Asynchronous Boot mode, the CPU can fetch its instruction cycles from the Mobile DiskOnChip P3 Programmable Boot Block. After reading from this block and completing boot, Mobile DiskOnChip P3 returns to derive its internal clock signal from the CE#, OE# and WE# inputs. Please refer to Section 11.3 for read timing specifications for Asynchronous Boot mode.

10. DESIGN CONSIDERATIONS

10.1 General Guidelines

A typical RISC processor memory architecture is shown in Figure 17. It may include the following devices:

- **Mobile DiskOnChip P3:** Contains the OS image, applications, registry entries, back-up data, user files and data, etc. It can also be used to perform boot operation, thereby replacing the need for a separate boot device.
- **CPU:** Mobile DiskOnChip P3 is compatible with all major CPUs in the mobile market, including:
 - o ARM-based CPUs
 - o Texas Instruments OMAP
 - o Intel StrongARM SA-1100/1 and XScale
 - o SuperH SH-3/4
 - o Motorola PowerPC MPC8xx and DragonBall MX1
 - o Philips PR31700
 - o NEC VRSeries VR3/4xxxx
- **Boot Device:** ROM or NOR flash that contains the boot code required for system initialization, kernel relocation, loading the operating systems and/or other applications and files into the RAM and executing them.
- **RAM/DRAM Memory:** This memory is used for code execution.
- **Other Devices:** A DSP processor, for example, may be used in a RISC architecture for enhanced multimedia support.

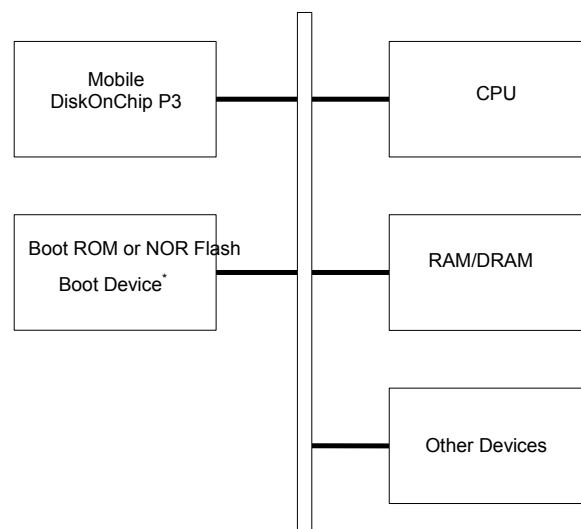

When used as a boot device, Mobile DiskOnChip P3 eliminates the need for a dedicated boot ROM/NOR device.

Figure 17: Typical System Architecture Using Mobile DiskOnChip P3

10.2 Standard NOR-Like Interface

Mobile DiskOnChip P3 uses a NOR-like interface that can easily be connected to any microprocessor bus. With a standard interface, it requires 13 address lines, 8 data lines and basic memory control signals (CE#, OE#, WE#), as shown in Figure 18 below. Typically, Mobile DiskOnChip P3 can be mapped to any free 8KB memory space. In a PC-compatible platform, it is usually mapped into the BIOS expansion area. If the allocated memory window is larger than 8KB, an automatic anti-aliasing mechanism prevents the firmware from being loaded more than once during the ROM expansion search.

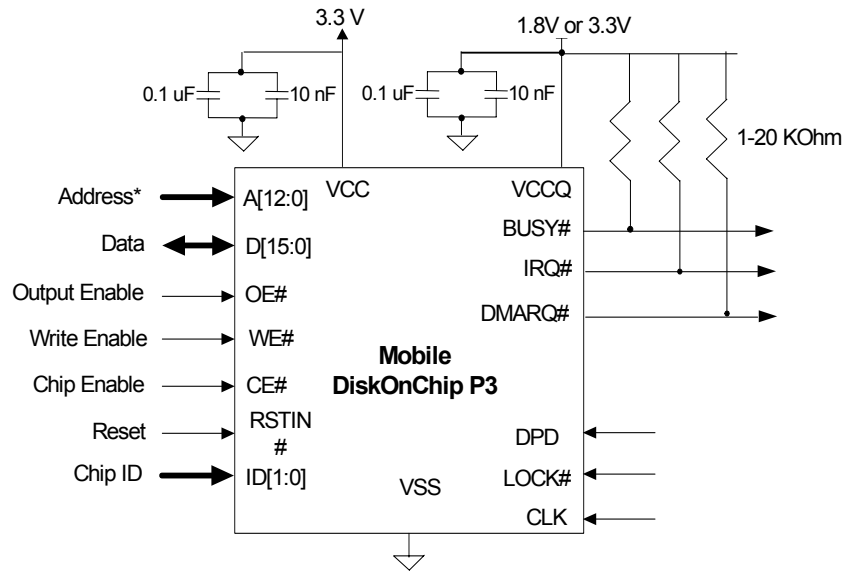

(*) Address A0 is multiplexed with the DPD signal.

Figure 18: Standard System Interface

- Notes:
1. The 0.1 μ F and the 10 nF low-inductance high-frequency capacitors must be attached to each of the device's VCC and VSS pins/balls. These capacitors must be placed as close as possible to the package leads.
 2. Mobile DiskOnChip P3 is an edge-sensitive device. CE#, OE# and WE# should be properly terminated (according to board layout, serial parallel or both terminations) to avoid signal ringing.

10.3 Multiplexed Interface

With a multiplexed interface, Mobile DiskOnChip P3 requires the signals shown in Figure 19 below.

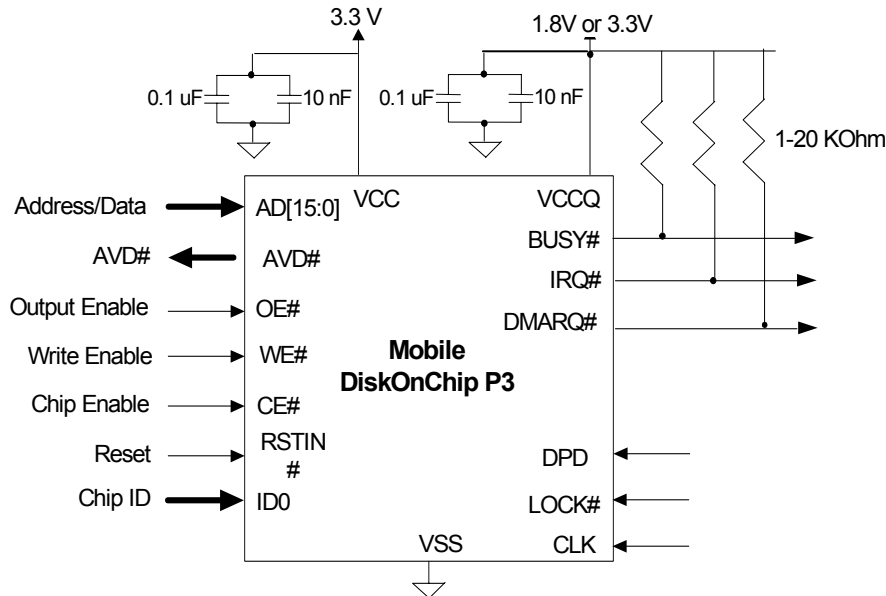

Figure 19: Multiplexed System Interface

10.4 Connecting Control Signals

10.4.1 Standard Interface

When using a standard NOR-like interface, connect the control signals as follows:

- A[12:0] – Connect these signals to the host's address signals (see Section 10.8 for platform-related considerations). Address signal A[0] is multiplexed with the DPD signal.
- D[15:0] – Connect these signals to the host's data signals (see Section 10.8 for platform-related considerations).
- Output Enable (OE#) and Write Enable (WE#) – Connect these signals to the host RD# and WR# signals, respectively.
- Chip Enable (CE#) – Connect this signal to the memory address decoder. Most RISC processors include a programmable decoder to generate various Chip Select (CS) outputs for different memory zones. These CS signals can be programmed to support different wait states to accommodate Mobile DiskOnChip P3 timing specifications.
- Power-On Reset In (RSTIN#) – Connect this signal to the host active-low Power-On Reset signal.

- Chip Identification (ID[1:0]) – Connect these signals as shown in Figure 18. Both signals must be connected to VSS if the host uses only one DiskOnChip. If more than one device is being used, refer to Section 10.6 for more information on device cascading.
- Busy (BUSY#) – This signal indicates when the device is ready for first access after reset. It may be connected to an input port of the host, or alternatively it may be used to hold the host in a wait-state condition. The later option is required for hosts that boot from Mobile DiskOnChip P3.
- DMARQ# (DMA Request) – Output used to control multi-page DMA operations. Connect this output to the DMA controller of the host platform.
- IRQ# (Interrupt Request) – Connect this signal to the host interrupt.
- Lock (LOCK#) – Connect to a logical **0** to prevent the usage of the protection key to open a protected partition. Connect to logical **1** in order to enable usage of protection keys.
- Deep-Power Down (DPD) – multiplexed with A[0].
- 8/16 Bit Interface Configuration (IF_CFG) – This signal is required for configuring the device for 8- or 16-bit access mode. When negated, the device is configured for 8-bit access mode. When asserted, 16-bit access mode is operative.
- Clock (CLK) – This input is used to support MultiBurst operation when reading flash data. Refer to Section 4.1 for further information on MultiBurst operation.

10.4.2 Multiplexed Interface

Mobile DiskOnChip P3 can use a multiplexed interface to connect to the multiplexed bus (asynchronous read/write protocol). In this configuration, the ID[1] input is driven by the host's AVD# signal, and the D[15:0] pins/balls, used for both address inputs and data, are connected to the host AD[15:0] bus. As with a standard interface, only address bits [12:0] are significant.

This mode is automatically entered when a falling edge is detected on ID[1]. This edge must occur after RSTIN# is negated and before OE# and CE# are both asserted; i.e., the first read cycle made to DiskOnChip must observe the multiplexed mode protocol. See Section 11.3 for more information about the related timing requirements.

Please refer to Section 2.3 for pinout and signal descriptions and to Section 11.3 for timing specifications for a multiplexed interface.

10.5 Implementing the Interrupt Mechanism

10.5.1 Hardware Configuration

To configure the hardware for working with the interrupt mechanism, connect the IRQ# pin/ball to the host interrupt input.

Note: A nominal 10 K Ω pull-up resistor must be connected to this pin/ball.

10.5.2 Software Configuration

Configuring the software to support the IRQ# interrupt is performed in two stages.

Stage 1

Configure the software so that when the system is initialized, the following steps occur:

1. The correct value is written to the Interrupt Control register to configure Mobile DiskOnChip P3 for:
 - Interrupt source: Flash ready, data protection, last byte during DMA has been transferred, or BCH ECC error has been detected (used during multi-page DMA operations).
 - Output sensitivity: Either edge or level-triggered

Note: Refer to Section 8 for further information on the value to write to this register.

2. The host interrupt is configured to the selected input sensitivity, either edge or level-triggered.
3. The handshake mechanism between the interrupt handler and the OS is initialized.
4. The interrupt service routine to the host interrupt is connected and enabled.

Stage 2

Configure the software so that for every long flash I/O operation, the following steps occur:

1. The correct value is written to the Interrupt Control register to enable the IRQ# interrupt.

Note: Refer to Section 8 for further information on the value to write to this register.

2. The flash I/O operation starts.
3. Control is returned to the OS to continue other tasks. When the IRQ# interrupt is received, other interrupts are disabled and the OS is flagged.
4. The OS either returns control immediately to the TrueFFS driver, or waits for the appropriate condition to return control to the TrueFFS driver.

10.6 Device Cascading

When connecting Mobile DiskOnChip P3 256Mb using a standard interface, up to four devices can be cascaded with no external decoding circuitry. Figure 20 illustrates the configuration required to cascade four devices on the host bus (only the relevant cascading signals are included in this figure, although all other signals must also be connected). All pins/balls of the cascaded devices must be wired in common, except for ID0 and ID1. The ID input pins/balls are strapped to VCC or VSS, according to the location of each DiskOnChip. The ID pin/ball values determine the identity of each device. For example, the first device is identified by connecting the ID pins/balls as 00, and the last device by connecting the ID pins/balls as 11. Systems that use only one Mobile DiskOnChip P3 256Mb must connect the ID pins/balls as 00. Additional devices must be configured consecutively as 01, 10 and 11.

When Mobile DiskOnChip P3 256 Mb uses a multiplexed interface, the value of ID[1] is set to logic 0. Therefore, only two devices can be cascaded using ID[0].

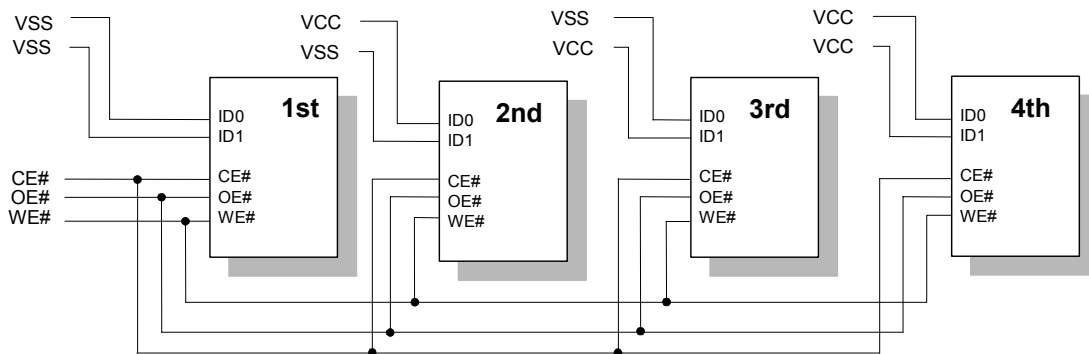

Figure 20: Standard Interface, Cascaded Configuration

Note: When more than one Mobile DiskOnChip P3 is cascaded, a boot block of 4KB is available. The Programmable Boot Block of each device is mapped to a unique address space.

10.7 Boot Replacement

A typical RISC architecture uses a boot ROM for system initialization. The boot ROM is also required to access Mobile DiskOnChip P3 during the boot sequence in order to load OS images and the device drivers.

M-Systems' Boot Software Development Kit (BDK) and DOS utilities enable full control of Mobile DiskOnChip P3 during the boot sequence. For a complete description of these products, refer to the *DiskOnChip Boot Software Development Kit (BDK)* developer guide and the *DiskOnChip Software Utilities* user manual. These tools enable the following operations:

- Formatting Mobile DiskOnChip P3
- Creating multiple partitions for different storage needs (OS images files, register entry files, back-up partitions, and FAT/NFTL partition)
- Loading the OS image file

Figure 21 illustrates the system boot flow using Mobile DiskOnChip P3 in a RISC architecture.

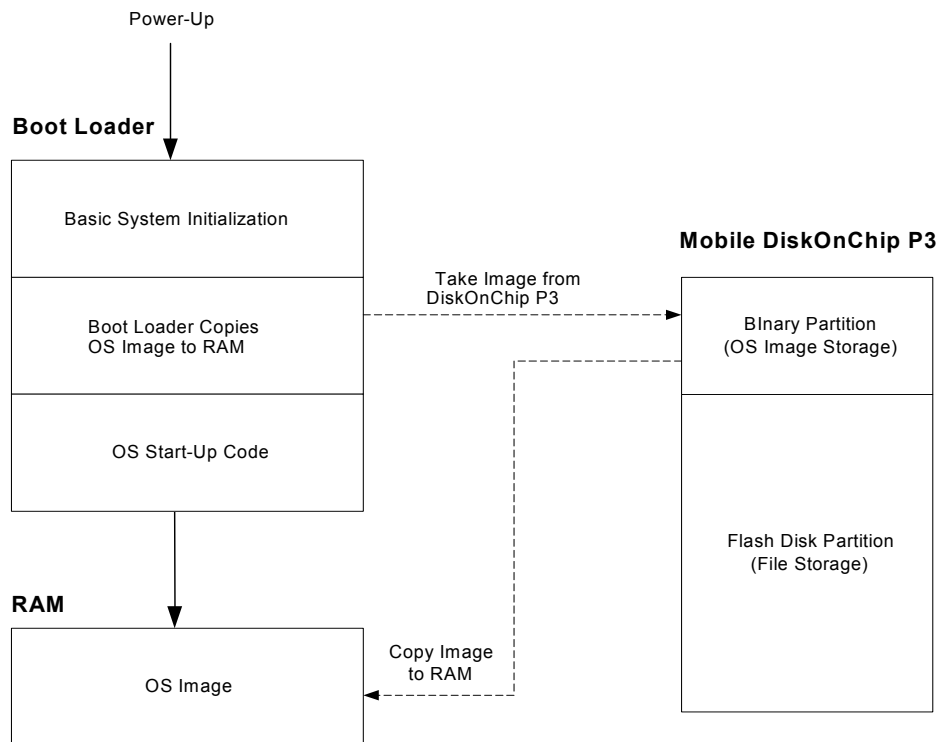

Figure 21: System Boot Flow with Mobile DiskOnChip P3

10.8 Platform-Specific Issues

Following is a description of hardware design issues for major embedded RISC processor families.

10.8.1 Wait State

Wait states can be implemented only when Mobile DiskOnChip P3 is designed in a bus that supports a Wait state insertion, and supplies a WAIT signal.

10.8.2 Big and Little Endian Systems

Mobile DiskOnChip P3 is a Little Endian device. Therefore, byte lane 0 (D[7:0]) is its Least Significant Byte (LSB) and byte lane 1 (D[15:8]) is its Most Significant Byte (MSB). Within the byte lanes, bit D0 and bit D8 are the least significant bits of their respective byte lanes. Mobile DiskOnChip P3 can be connected to a Big Endian device in one of two ways:

1. Make sure to identify byte lane 0 and byte lane 1 of your processor. Then, connect the data bus so that the byte lanes of the CPU match the byte lanes of Mobile DiskOnChip P3. Pay special attention to processors that also change the bit ordering within the bytes (for example, PowerPC). Failing to follow these rules results in improper connection of Mobile DiskOnChip P3, and prevents the TrueFFS driver from identifying it.
2. Set the bits SWAPH and SWAPL in the Endian Control register. This enables byte swapping when used with 16-bit hosts.

10.8.3 Busy Signal

The Busy signal (BUSY#) indicates that Mobile DiskOnChip P3 has not yet completed internal initialization. After reset, BUSY# is asserted while the IPL is downloaded into the internal boot block and the Data Protection Structures (DPS) are downloaded to the Protection State Machines. Once the download process is completed, BUSY# is negated. It can be used to delay the first access to Mobile DiskOnChip P3 until it is ready to accept valid cycles.

Note: The TrueFFS driver does NOT use this signal to indicate that the flash is in busy state (e.g. program, read, or erase).

10.8.4 Working with 8/16/32-Bit Systems

Mobile DiskOnChip P3 uses a 16-bit data bus and supports 16-bit data access by default. However, it can be configured to support 8 or 32-bit data access mode. This section describes the connections required for each mode.

The default of the TrueFFS driver for Mobile DiskOnChip P3 is set to work in 16-bit mode. It must be specially configured to support 8 and 32-bit mode. Please see TrueFFS documentation for further details.

Note: The DiskOnChip data bus must be connected to the Least Significant Bits (LSB) of the system. The system engineer must verify whether the matching host signals are SD[7:0], SD[15:8] or D[31:24].

8-Bit (Byte) Data Access Mode

When configured for 8-bit operation, pin/ball IF_CFG should be connected to VSS, and data lines D[15:8] are internally pulled up and may be left unconnected. The controller routes odd and even address accesses to the appropriate byte lane of the flash and RAM.

Host address SA0 must be connected to Mobile DiskOnChip P3 A0, SA1 must be connected to A1, etc.

16-Bit (Word) Data Access Mode

To set Mobile DiskOnChip P3 to work in 16-bit mode, the IF_CFG pin/ball must be connected to VCC.

In 16-bit mode, the Programmable Boot Block is accessed as a true 16-bit device. It responds with the appropriate data when the CPU issues either an 8-bit or 16-bit read cycle. The flash area is accessed as a 16/32-bit device, regardless of the interface bus width. This has no affect on the design of the interface between Mobile DiskOnChip P3 and the host. The TrueFFS driver handles all issues regarding moving data in and out of Mobile DiskOnChip P3.

See Table 6 for A0 and IF_CFG settings for various functionalities with 8/16-bit data access.

Table 6: Active Data Bus Lines in 8/16-Bit Configuration

A0	IF_CFG	Functionality
0	1	16-bit access through both buses
0	0	8-bit access to even bytes through low 8-bit bus
1	0	8-bit access to odd bytes through low 8-bit bus
1	1	Illegal

32-Bit (Double Word) Data Access Mode

In a 32-bit bus system that cannot execute byte or word aligned accesses, the system address lines SA0 and SA1 are always 0. Consecutive double words (32-bit words) are differentiated by SA2 toggling. Therefore, in 32-bit systems that support only 32-bit data access cycles, Mobile DiskOnChip P3 signal A0 is connected to VSS and A1 is connected to the first system address bit that toggles; i.e., SA2.

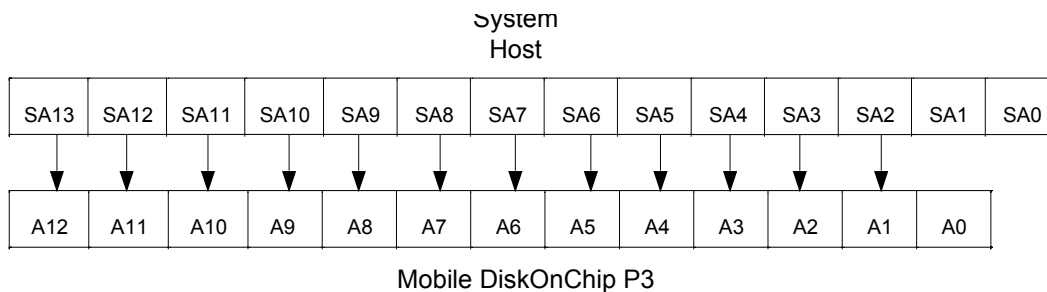

Note: The prefix “S” indicates system host address lines

Figure 22: Address Shift Configuration for 32-Bit Data Access Mode

10.9 Design Environment

Mobile DiskOnChip P3 provides a complete design environment consisting of:

- Evaluation boards (EVBs) for enabling software integration and development with Mobile DiskOnChip P3, even before the target platform is available.
- Programming solutions:
 - o GANG programmer
 - o Programming house
 - o On-board programming
- TrueFFS Software Development Kit (SDK) and Boot Software Development Kit (BDK)
- DOS utilities:
 - o DFORMAT
 - o GETIMAGE/PUTIMAGE
 - o DINFO
- Documentation:
 - o Data sheet
 - o Application notes
 - o Technical notes
 - o Articles
 - o White papers

Please visit the M-Systems website (www.m-sys.com) for the most updated documentation, utilities and drivers.

11. PRODUCT SPECIFICATIONS

11.1 Environmental Specifications

11.1.1 Operating Temperature

Commercial temperature range: 0°C to +70°C

Extended temperature range: -40°C to +85°C

11.1.2 Thermal Characteristics

Table 7: Thermal Characteristics

Thermal Resistance (°C/W)	
Junction to Case (θ_{JC}): 30	Junction to Ambient (θ_{JA}): 85

11.1.3 Humidity

10% to 90% relative, non-condensing

11.1.4 Endurance

Mobile DiskOnChip P3 is based on NAND flash technology, which guarantees a minimum of 100,000 erase cycles. Due to the TrueFFS wear-leveling algorithm, the life span of all DiskOnChip products is significantly prolonged. M-Systems' website (www.m-sys.com) provides an online life-span calculator to facilitate application-specific endurance calculations.

11.2 Electrical Specifications

11.2.1 Absolute Maximum Ratings

Table 8: Absolute Maximum Ratings

Symbol	Parameter	Rating1	Unit
VCC	DC core supply voltage	-0.6 to 4.6	V
VCCQ	DC I/O supply voltage	-0.6 to 4.6	V
T _{1SUPPLY}	Maximum duration of applying VCCQ without VCC, or VCC without VCCQ	1000	msec
I _{IN}	Input pin/ball current (25 °C)	-10 to 10	mA
V _{IN} ²	Input pin/ball voltage	-0.6 to VCCQ+0.3V, 4.6V max	V
T _{STG}	Storage temperature	-55 to 150	°C
ESD: Charged Device Model	ESD _{CDM}	1000	V
ESD: Human Body Model	ESD _{HBM}	2000	V

1. Permanent device damage may occur if absolute maximum ratings are exceeded. Exposure to absolute maximum rating conditions for extended periods may affect device reliability.
2. The voltage on any ball may undershoot to -2.0 V or overshoot to 6.6V for less than 20 ns.
3. When operating Mobile DiskOnChip P3 with separate power supplies for VCC and VCCQ, it is recommended to turn both supplies on and off simultaneously. Providing power separately (either at power-on or power-off) can cause excessive power dissipation. Damage to the device may result if this condition persists for more than 1 second.

11.2.2 Capacitance

Table 9: Capacitance

Symbol	Parameter	Conditions	Min	Typ	Max	Unit
C_{IN}	Input capacitance	$V_{IN} = 0V$			10	pF
C_{OUT}	Output capacitance	$V_O = 0V$			10	pF

Capacitance is not 100% tested.

11.2.3 DC Electrical Characteristics Over Operating Range

See Table 10 and Table 11 for DC characteristics for VCCQ ranges 1.65-2.0V and 2.5-3.6V I/O, respectively.

Table 10: DC Characteristics, VCCQ = 1.65-2.0V I/O

Symbol	Parameter	Conditions	Min	Typ	Max	Unit
VCC	Core supply voltage		2.5	3.0	3.6	V
VCCQ	Input/Output supply voltage		1.65	1.8	2.00	V
V_{IH}	High-level input voltage		$VCCQ - 0.4$			V
V_{IL}	Low-level input voltage				0.4	V
V_{OH}	High-level output voltage	$I_{OH} = -100\mu A$	$VCCQ - 0.1$			V
V_{OL}	Low-level output voltage	D[15:0] $I_{OL} = 100\mu A$			0.1	V
		IRQ#, BUSY#, DMARQ# 4mA			0.3	V
I_{ILK}	Input leakage current ²				± 10	μA
I_{IOLK}	Output leakage current				± 10	μA
I_{CC}	Active supply current ¹ , VCC pin/ball	Cycle Time = 100 ns		10	45	mA
I_{CCS}	Standby supply current, VCC pin/ball	Deep Power-Down mode ³		10	40	μA

1. VCC = 3V, VCCQ = 1.8V, Outputs open
2. The CE# input includes a pull-up resistor which sources 0.3~1.4 (TBD) μA at $V_{in}=0V$
3. Deep Power-Down mode is achieved by asserting RSTIN# (when in Normal mode) or writing the proper write sequence to the DiskOnChip registers, and asserting the CE# input = VCCQ.

Table 11: DC Characteristics, VCCQ = 2.5V-3.6V

Symbol	Parameter	Conditions	Min	Typ	Max	Unit
VCC	Core supply voltage		2.5	3.3	3.6	V
VCCQ	Input/Output supply voltage		2.5	3.3	3.6	V
V_{IH}	High-level input voltage		2.1			V
V_{IL}	Low-level input voltage				0.7	V
I_{OHmax}	Maximum high level output current	$3.0V < VCCQ < 3.6V$	-4			mA
		$2.5V < VCCQ < 3.0V$	-4			mA

Symbol	Parameter	Conditions	Min	Typ	Max	Unit
I_{OLmax}	Maximum low-level output current	$3.0V < VCCQ < 3.6V$	8			mA
		$2.5V < VCCQ < 3.0V$	5			mA
I_{ILK}	Input leakage current ²				±10	µA
I_{IOLK}	Output leakage current				±10	µA
V_{OH}	High-level output voltage	$I_{OH} = I_{OHmax}$ $2.5V < VCCQ < 2.7V$	VCCQ-0.3			V
		$I_{OH} = I_{OHmax}$ $2.5V < VCCQ < 3.6V$	2.4			
V_{OL}	Low-level output voltage	$I_{OL} = I_{OLmax}$			0.4	V
I_{CC}	Active supply current, VCC+VCCQ pins/balls ¹	Cycle Time = 100 ns		10	45	mA
I_{CCS}	Standby supply current, VCC+VCCQ pins/balls	Deep Power-Down mode ³		10	40	µA

1. VCC = VCCQ = 3.3V, Outputs open
2. The CE# input includes a pull-up resistor which sources 0.3~1.4 (TBD) µA at Vin=0V
3. Deep Power-Down mode is achieved by asserting RSTIN# (when in Normal mode) or writing the proper write sequence to the DiskOnChip registers, and asserting the CE# input = VCCQ.

11.2.4 AC Operating Conditions

Timing specifications are based on the conditions defined below.

Table 12: AC Characteristics

Parameter	VCCQ = 1.65-2.0V	VCCQ = 2.5-3.6V
Ambient temperature (TA)	-40°C to +85°C	-40°C to +85°C
Core supply voltage (VCC)	2.5V to 3.6V	2.5V to 3.6V
Input pulse levels	0.2/VCCQ-0.2V	0V/2.5V
Input rise and fall times	3 ns	3 ns
Input timing levels	0.9V	1.5V
Output timing levels	0.9V	1.5V
Output load	30 pF	100 pF

11.3 Timing Specifications

11.3.1 Read Cycle Timing Standard Interface

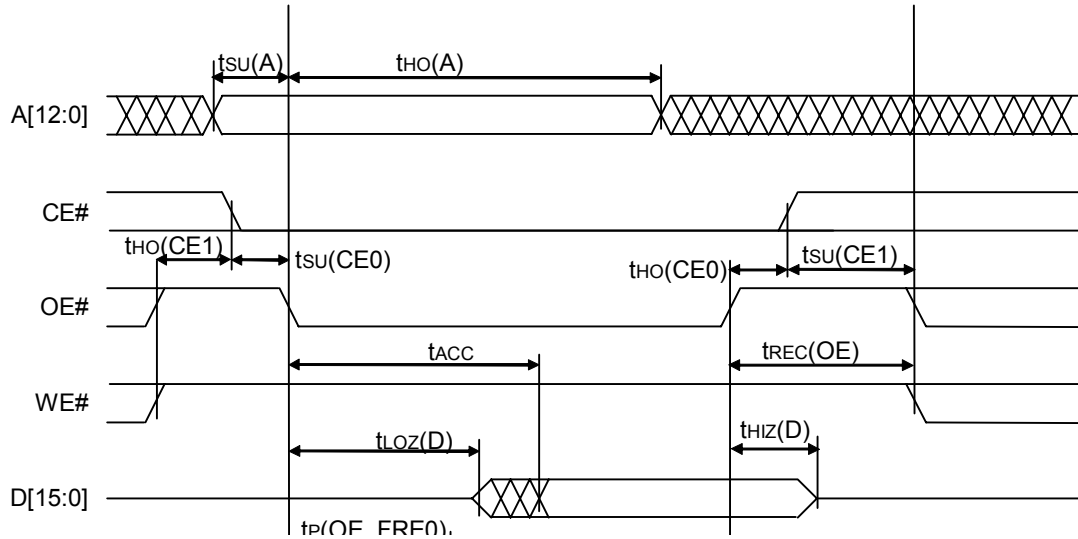

Figure 23: Standard Interface, Read Cycle Timing

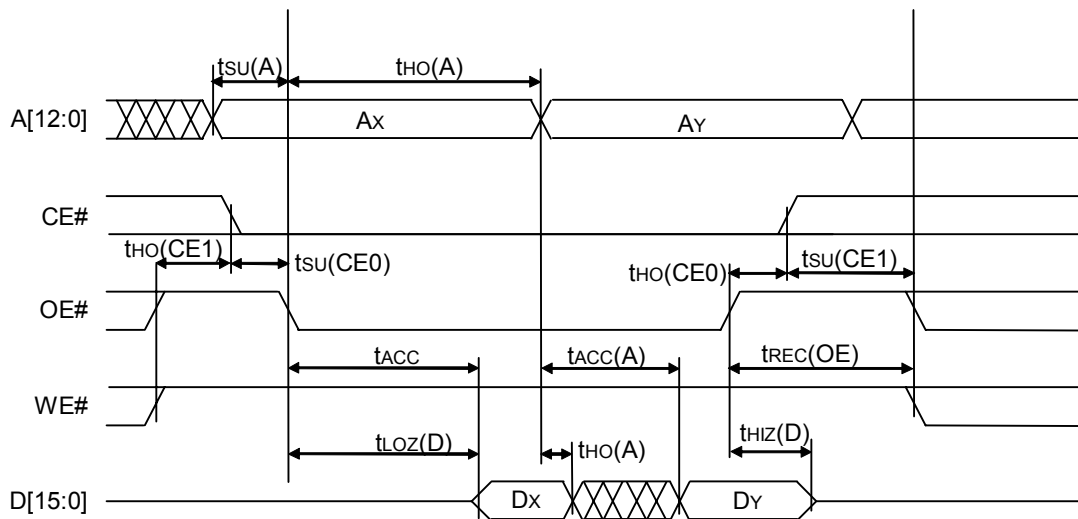

Figure 24: Standard Interface Read Cycle Timing – Asynchronous Boot Mode

Table 13: Standard Interface Read Cycle Timing Parameters

Symbol	Description	VCCQ=VCC VCC=2.5-3.6V		VCCQ=1.65-2.0V VCC=2.5-3.6V		Units	
		Min	Max	Min	Max		
Tsu(A)	Address to OE# ↓ setup time	-2		-2		ns	
Tho(A)	OE# ↓ to Address hold time ¹	24		24		ns	
Tsu(CE0)	CE# ↓ to OE# ↓ setup time ²	—		—		ns	
Tho(CE0)	OE# ↑ to CE# ↑ hold time ³	—		—		ns	
Tho(CE1)	OE# or WE# ↑ to CE# ↓ hold time	5		5		ns	
Tsu(CE1)	CE# ↑ to WE# ↓ or OE# ↓ setup time	5		5		ns	
Trec(OE)	OE# negated to start of next cycle	20		20		ns	
Tacc	Read access time (RAM) ¹	Turbo operation		87		ns	
		Normal operation		84			
	Read access time (all other addresses) ³	Turbo operation		33			
		Normal operation		55			
Tloz(D)	OE# ↓ to D driven ⁴	Turbo operation	5		5	ns	
	OE# ↓ to D driven ⁴	Normal operation	14		14	ns	
Thiz(D)	OE# ↑ to D Hi-Z delay ⁴			TBD		TBD	ns
tacc(A)	RAM Read access time from A[9:0]	Asynchronous Boot mode		76		77	ns
tho(A-D)	Data hold time from A[9:0] (RAM)	Asynchronous Boot mode	0		0		ns

1. Add 260 ns (TBD) on the first read cycle when exiting Power-Down mode. See Section 6.3 for more information.
2. CE# may be asserted any time before or after OE# is asserted. If CE# is asserted after OE#, all timing relative to when OE# was asserted will be referenced to the time CE# was asserted.
3. CE# may be negated any time before or after OE# is negated. If CE# is negated before OE#, all timing relative to when OE# was negated will be referenced to the time CE# was negated.
4. No load (C_L = 0 pF).

11.3.2 Write Cycle Timing Standard Interface

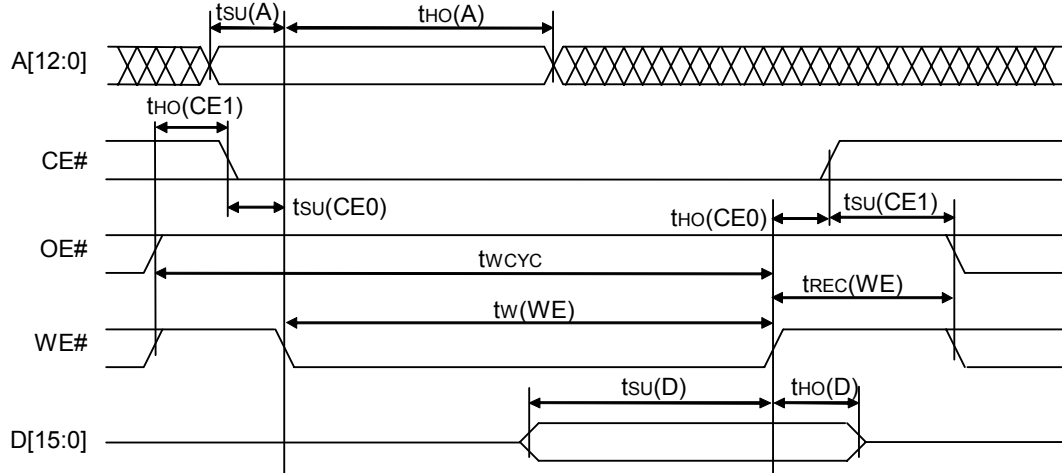

Figure 25: Standard Interface Write Cycle Timing

Table 14: Standard Interface Write Cycle Parameters

Symbol	Description	VCCQ=VCC VCC=2.5-3.6V		VCCQ=1.65-2.0V VCC=2.5-3.6V		Units
		Min	Max	Min	Max	
Tsu(A)	Address to WE# ↓ setup time	-2		-2		ns
ThO(A)	WE# ↓ to Address hold time	24		24		ns
Tw(WE)	WE# asserted width (RAM)	38		38		ns
	WE# asserted width (all other addresses)	36		36		ns
Tsu(CE0)	CE# ↓ to WE# ↓ setup time ¹	--		--		ns
ThO(CE0)	WE# ↑ to CE# ↑ hold time ²	--		--		ns
ThO(CE1)	OE# or WE# ↑ to CE# ↓ hold time	5		5		ns
Tsu(CE1)	CE# ↑ to WE# ↓ or OE# ↓ setup time	5		5		ns
Trec(WE)	WE# ↑ to start of next cycle	20		20		ns
Tsu(D)	D to WE# ↑ setup time	27		27		ns
ThO(D)	WE# ↑ to D hold time	0		0		

1. CE# may be asserted any time before or after WE# is asserted. If CE# is asserted after WE#, all timing relative to WE# asserted should be referenced to the time CE# was asserted.
2. CE# may be negated any time before or after WE# is negated. If CE# is negated before WE#, all timing relative to WE# negated will be referenced to the time CE# was negated.

11.3.3 Read Cycle Timing Multiplexed Interface

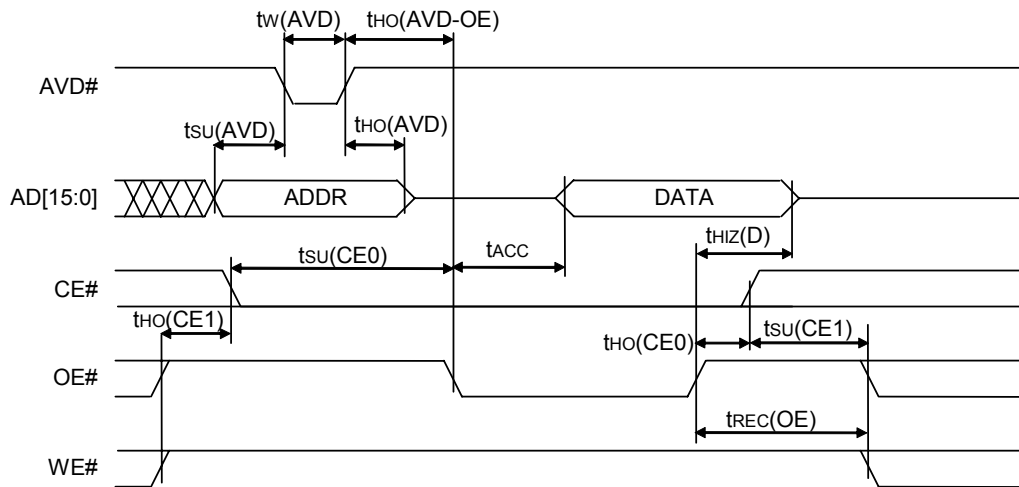

Figure 26: Multiplexed Interface Read Cycle Timing

Table 15: Multiplexed Interface Read Cycle Parameters

Symbol	Description	VCCQ=VCC VCC=2.5-3.6V		VCCQ=1.65-2.0V VCC=2.5-3.6V		Units
		Min	Max	Min	Max	
tsu(AVD)	Address to AVD# ↓ setup time	5		5		ns
tho(AVD)	Address to AVD# ↑ hold time	7		7		ns
Tw(AVD)	AVD# low pulse width	12		12		ns
thO(AVD-OE)	AVD# ↑ to OE# ↓ hold time ¹	0		0		ns
tsu(CE0)	CE# ↓ to OE# ↓ setup time ¹	—		—		ns
tho(CE0)	OE# ↑ to CE# ↑ hold time ²	—		—		ns
tho(CE1)	OE# or WE# ↑ to CE# ↓ hold time	5		5		ns
tsu(CE1)	CE# ↑ to WE# ↓ or OE# ↓ setup time	5		5		ns
trec(OE)	OE# negated to start of next cycle	20		20		ns
Tacc	Read access time (RAM)	Turbo operation		87	88	ns
		Normal operation		84	85	
	Read access time (all other addresses)	Turbo operation		33	34	
		Normal operation		55	56	
tloz(D)	OE# ↓ to D driven ³	Turbo operation		5	5	ns
		Normal operation		14	14	
Thiz(D)	OE# ↑ to D Hi-Z delay ³		TBD		TBD	ns

1. CE# may be asserted any time before or after OE# is asserted. If CE# is asserted after OE#, all timing relative to OE# asserted will be referenced instead to the time of CE# asserted.
2. CE# may be negated any time before or after OE# is negated. If CE# is negated before OE#, all timing relative to OE# negated will be referenced instead to the time of CE# negated.
3. No load (C_L = 0 pF).

11.3.4 Write Cycle Timing Multiplexed Interface

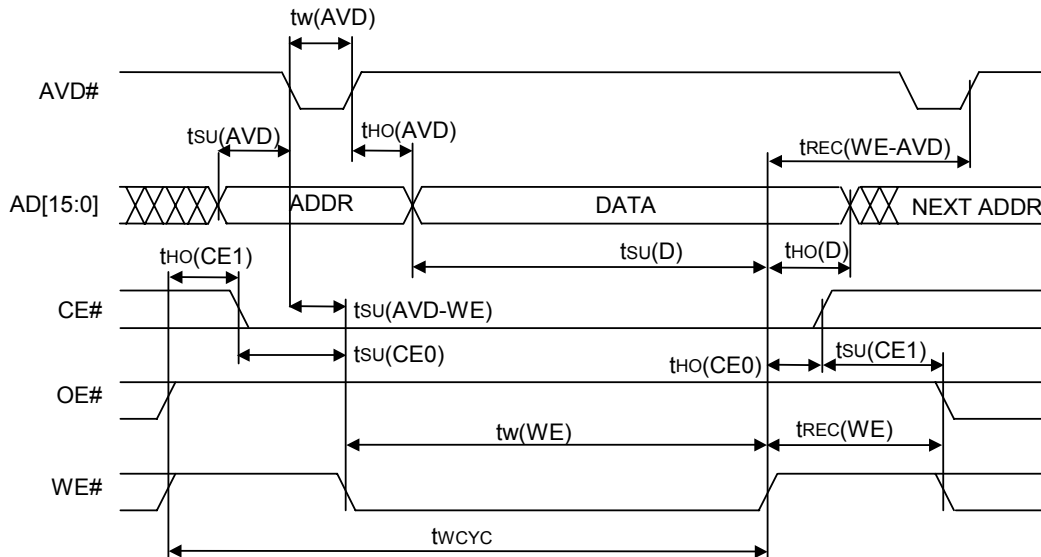

Figure 27: Multiplexed Interface Write Cycle Timing

Table 16: Multiplexed Interface Write Cycle Parameters

Symbol	Description	VCCQ=VCC VCC=2.5-3.6V		VCCQ=1.65-2.0V VCC=2.5-3.6V		Units
		Min	Max	Min	Max	
		tsu(AVD)	Address to AVD# ↓ setup time	5		
tho(AVD)	Address to AVD# ↑ hold time	7		7		ns
Tw(AVD)	AVD# low pulse width	12		12		ns
tsu(AVD-WE)	AVD# ↓ to WE# ↓ setup time ¹	4		4		ns
tw(WE)	WE# asserted width (RAM) ³	38		38		ns
	WE# asserted width (all other addresses)	36		36		
tsu(CE0)	CE# ↓ to WE# ↓ setup time ¹	—		—		ns
tho(CE0)	WE# ↑ to CE# ↑ hold time ²	—		—		ns
tho(CE1)	OE# or WE# ↑ to CE# ↓ hold time	5		5		ns
tsu(CE1)	CE# ↑ to WE# ↓ or OE# ↓ setup time	5		5		ns
trec(WE)	WE# ↑ to start of next cycle	20		20		ns
Tsu(D)	D to WE# ↑ setup time	27		27		ns
Tho(D)	WE# ↑ to D hold time	0		0		ns

1. CE# may be asserted any time before or after WE# is asserted. If CE# is asserted after WE#, all timing relative to WE# asserted will be referenced instead to the time of CE# asserted.
2. CE# may be negated any time before or after WE# is negated. If CE# is negated before WE#, all timing relative to WE# negated will be referenced instead to the time of CE# negated.
3. WE# may be asserted before or after the rising edge of AVD#. The beginning of the WE# asserted pulse width spec is measured from the later of the falling edge of WE# or the rising edge of AVD#.

11.3.5 Read Cycle Timing MultiBurst

In Figure 28, the MultiBurst Control register values are: LATENCY=0, LENGTH=4, CLK_INV=0.

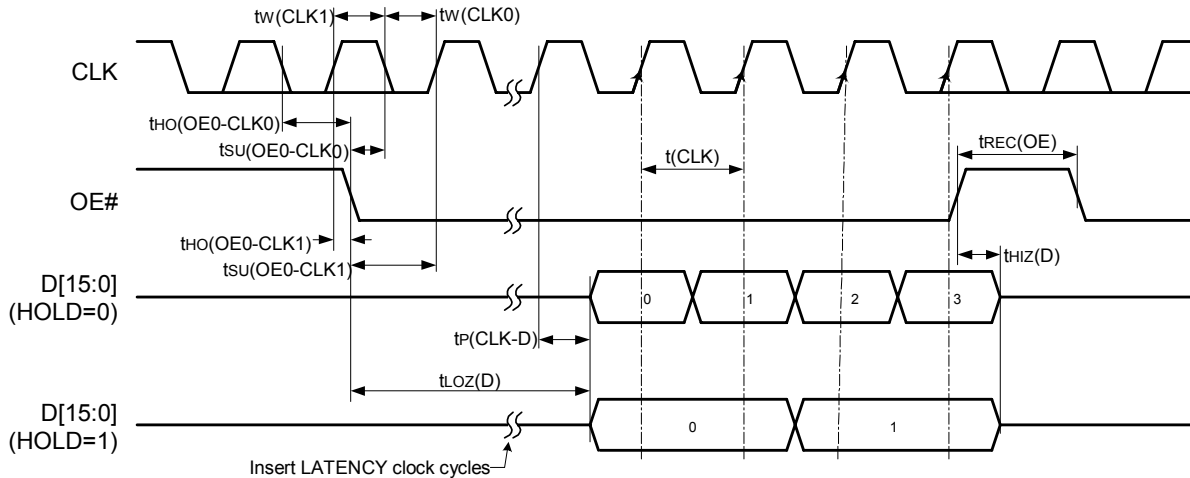

Figure 28: MultiBurst Read Timing

Note: Shown with Burst Mode Controller register values: LATENCY=0, LENGTH=4.

Table 17: MultiBurst Read Cycle Parameters

Symbol	Description	VCCQ=VCC VCC=2.5-3.6V		VCCQ=1.65-2.0V VCC=2.5-3.6V		Units
		Min	Max	Min	Max	
t _{SU} (OE0-CLK1)	OE# ↓ to CLK ↑ setup time ^{1, 4}	10		10		ns
t _{SU} (OE0-CLK0)	OE# ↓ to CLK ↓ setup time ^{1, 5}	10		10		ns
t _{HO} (OE0-CLK1)	CLK ↑ to OE# ↓ hold time ^{1, 4}	1		1		ns
t _{HO} (OE0-CLK0)	CLK ↓ to OE# ↓ hold time ^{1, 5}	1		1		ns
t _P (CLK-D)	CLK ↑ to D delay		24		25	ns
t _w (CLK1)	CLK high pulse width ⁶	7		7		ns
	CLK high pulse width ⁷	7		7		ns
t _w (CLK0)	CLK low pulse width ⁶	8		8		ns
	CLK low pulse width ⁷	8		8		ns
t(CLK)	CLK period ⁶	27		27		ns
	CLK period ⁷	29		29		ns
t _{REC} (OE)	OE# negated to start of next cycle ²	9		9		ns
t _{LOZ} (D)	OE# ↓ to D driven ^{1, 3}		14		14	ns
	Turbo operation					

Symbol	Description		VCCQ=VCC		VCCQ=1.65-2.0V		Units
			VCC=2.5-3.6V		VCC=2.5-3.6V		
			Min	Max	Min	Max	
	OE# ↓ to D driven ^{1,3}	Normal operation		5		5	ns
tHIZ(D)	OE# ↑ to D Hi-Z delay ¹			TBD		TBD	ns

1. CE# may be asserted any time before or after OE# is asserted. If CE# is asserted after OE#, all timing relative to OE# asserted will be referenced instead to the time of CE# asserted.
2. CE# may be negated any time before or after OE# is negated. If CE# is negated before OE#, all timing relative to OE# negated will be referenced instead to the time of CE# negated.
3. No load (CL = 0 pF).
4. Applicable only if the CLK_INV bit of the MultiBurst Mode Control register is 0.
5. Applicable only if the CLK_INV bit of the MultiBurst Mode Control register is 1.
6. Applicable only if the HOLD bit of the MultiBurst Mode Control register is 0.
7. Applicable only if the HOLD bit of the MultiBurst Mode Control register is 1

11.3.6 Power Supply Sequence

When operating Mobile DiskOnChip P3 with separate power supplies powering the VCCQ and VCC rails, it is desirable to turn both supplies on and off simultaneously. Providing power to one supply rail and not the other (either at power-on or power-off) can cause excessive power dissipation. Damage to the device may result if this condition persists for more than 500 msec.

11.3.7 Power-up Timing

Mobile DiskOnChip P3 is reset by assertion of the RSTIN# input. When this signal is negated, Mobile DiskOnChip P3 initiates a download procedure from the flash memory into the internal Programmable Boot Block. During this procedure, Mobile DiskOnChip P3 does not respond to read or write accesses.

Host systems must therefore observe the requirements described below for first access to Mobile DiskOnChip P3. Any of the following methods may be employed to guarantee first-access timing requirements:

- Use a software loop to wait at least Tp (BUSY1) before accessing the device after the reset signal is negated.
- Poll the state of the BUSY# output.
- Poll the DL_RUN bit of the Download Status register until it returns 0. The DL_RUN bit will be 0 when BUSY# is negated.
- Use the BUSY# output to hold the host CPU in wait state before completing the first access which will be a RAM read cycle. The data will be valid when BUSY# is negated.

Hosts that use Mobile DiskOnChip P3 to boot the system must employ option 4 above or use another method to guarantee the required timing of the first-time access.

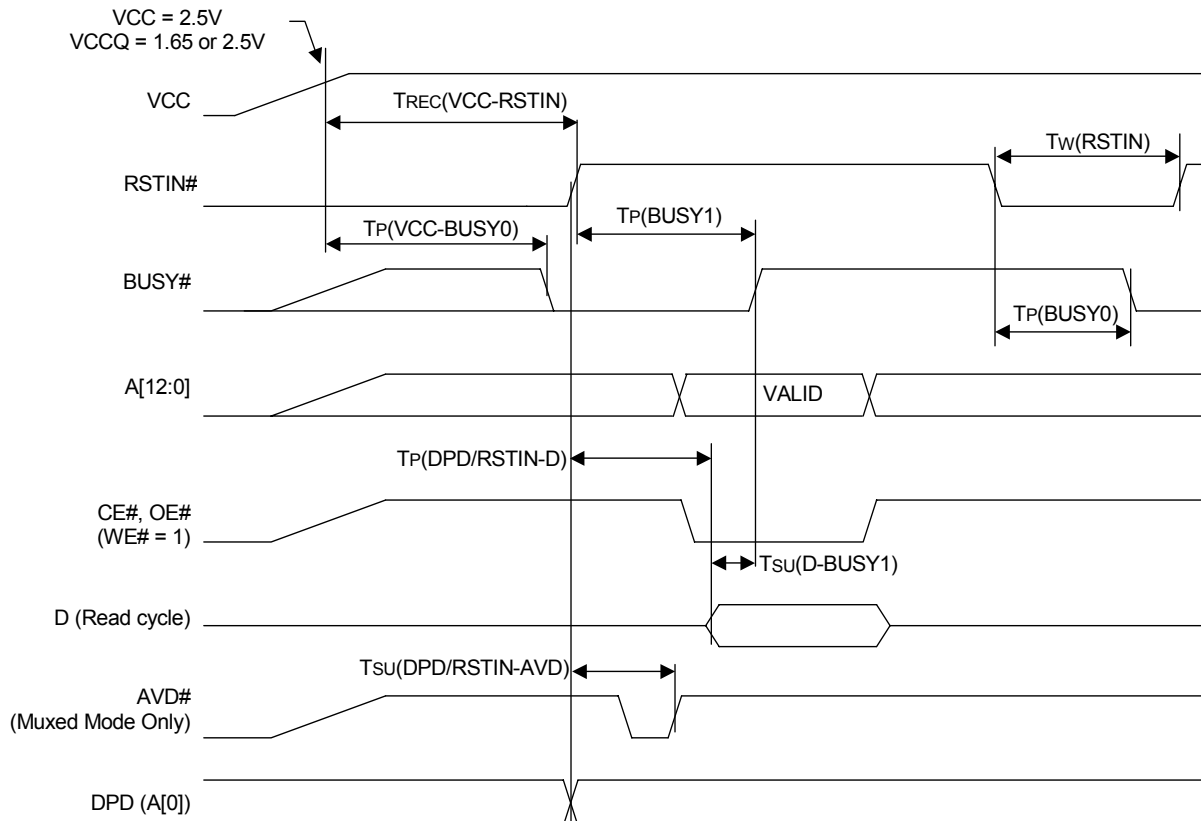

Figure 29: Reset Timing

Table 18: Power-Up Timing Parameters

Symbol	Description	Min	Max	Units
$T_{REC}(VCC-RSTIN)$	VCC/VCCQ stable to RSTIN# \uparrow ¹	500		μ s
$T_w(RSTIN)$	RSTIN# asserted pulse width	30		ns
$T_P(BUSY0)$	RSTIN# \downarrow to BUSY# \downarrow		50	ns
$T_P(BUSY1)$	RSTIN# \uparrow to BUSY# \uparrow ²		1055	μ s
$T_{su}(D-BUSY1)$	Data valid to BUSY# \uparrow ³	0		ns
$t_P(VCC-BUSY0)$	VCC/VCCQ stable to BUSY# \downarrow		500	μ s
$t_{su}(DPD/RSTIN-AVD)$ ^{4,6}	DPD transition or RSTIN# \uparrow to AVD# \uparrow	600		nS
$t_P(DPD/RSTIN-D)$ ^{5,6}	DPD transition or RSTIN# \uparrow to Data valid	660		nS

1. Specified from the final positive crossing of VCC above 2.7V and VCCQ above 1.65 or 2.5V.
2. If the assertion of RSTIN# occurs during a flash erase cycle, this time could be extended by up to 500 μ s.
3. Normal read/write cycle timing applies. This parameter applies only when the cycle is extended until the negation of the BUSY# signal.
4. Applies to multiplexed interface only.
5. Applies to SRAM mode only.
6. DPD transition refers to exiting Deep Power Down mode by toggling DPD (A[0]).
7. When operating Mobile DiskOnChip P3 with separate power supplies for VCC and VCCQ, it is recommended to turn both supplies on and off simultaneously. Providing power separately (either at power-on or power-off) can cause excessive power dissipation. Damage to the device may result if this condition persists for more than 1 second.

11.3.8 Interrupt Timing

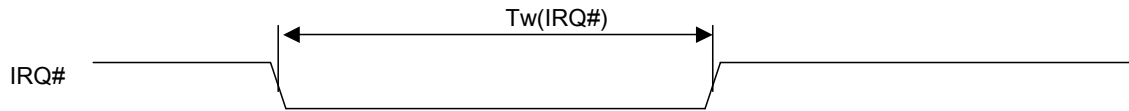
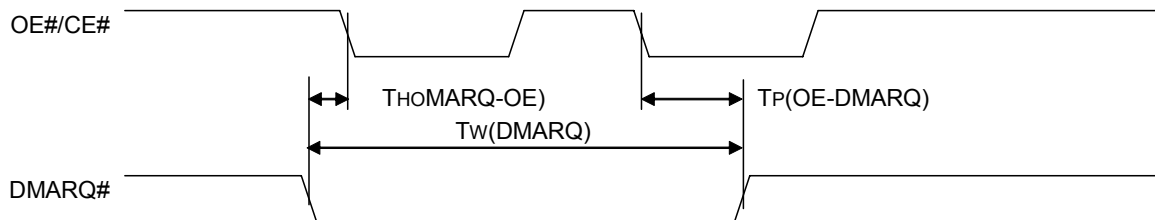

Figure 30: IRQ# Pulse Width in Edge Mode

Table 19: Interrupt Timing

Symbol	Description	Min	Max	Unit
Tw(IRQ#)	IRQ# asserted pulse width (Edge mode)	250	500	nsec

11.3.9 DMA Request Timing



Note: Polarity of DMARQ# may be inverted based on the NORMAL bit of DMA Control Register[0].

Figure 31: DMARQ# Pulse Width

Table 20: DMA Request Timing

Symbol	Description	Min	Max	Unit
Tw(DMARQ#)	DMARQ# asserted pulse width	250	500	nSec
Tho(DMARQ-OE)	DMARQ# asserted to start of cycle	0		nSec
tP(OE-DMARQ)	Start of cycle to DMARQ# negated		TBD	nSec

11.4 Mechanical Dimensions

TSOP-I dimensions: 20.0 ± 0.25 mm x 12.0 ± 0.10 mm x 1.2 ± 0.10 mm

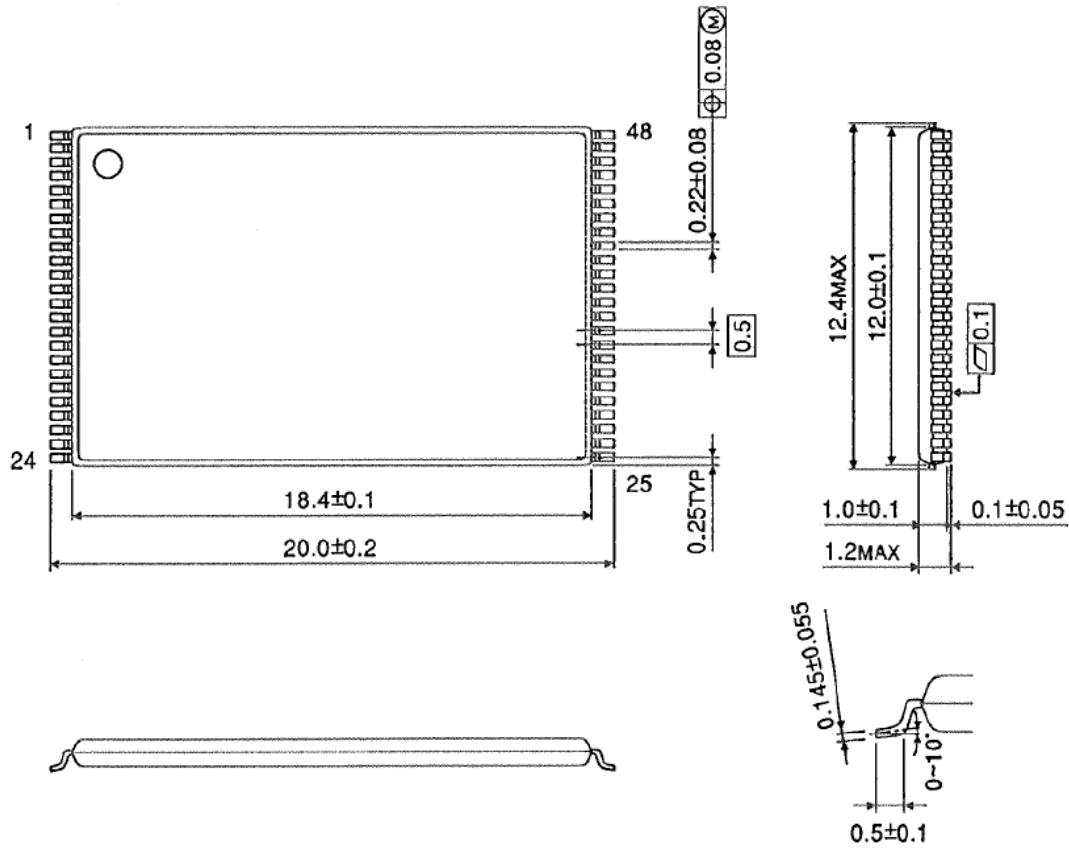

Figure 32: Mechanical Dimensions TSOP-I Package

FBGA dimensions: 7.0±0.20 mm x 10.0±0.20 mm x 1.2±0.10 mm
 Ball pitch: 0.8 mm

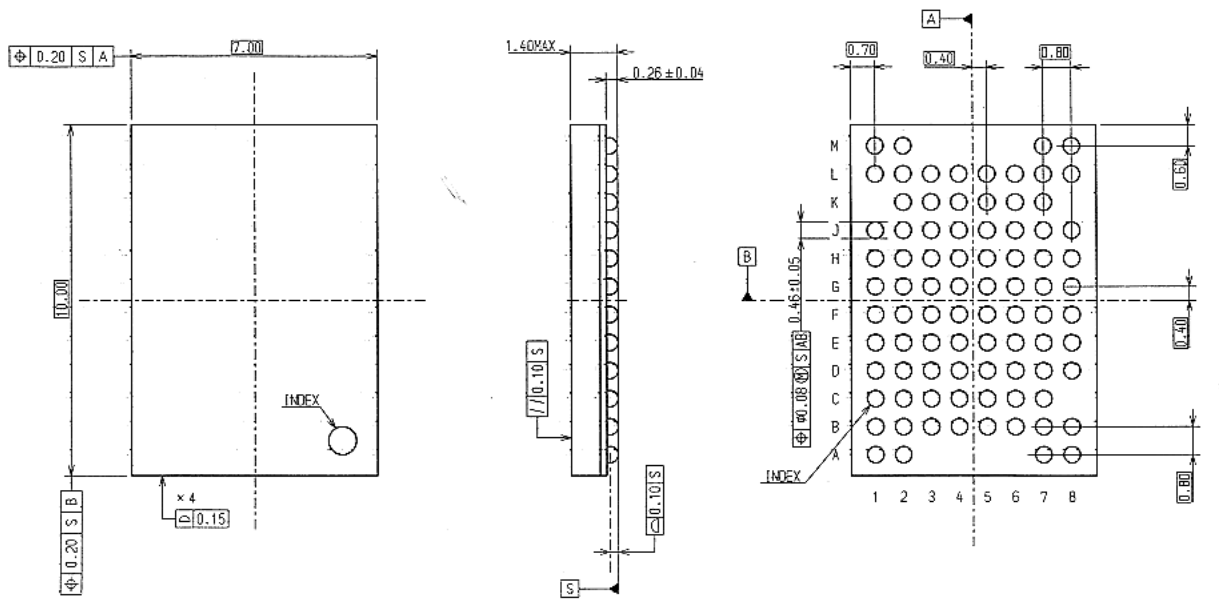

Figure 33: Mechanical Dimensions 7x10 FBGA Package

12. ORDERING INFORMATION

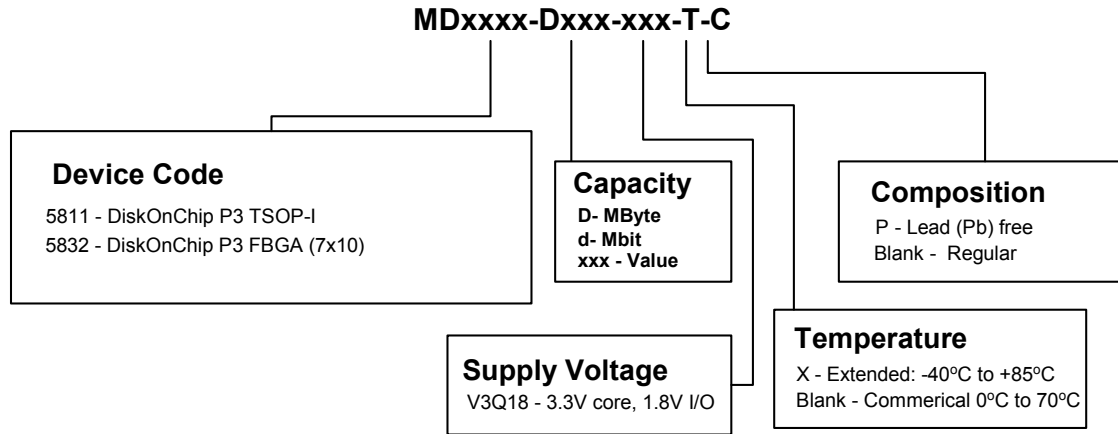

Figure 34: Ordering Information Structure

Refer to Table 21 for combinations currently available and the associated order numbers.

Table 21: Available Combinations

Ordering code	Capacity		Package		Temperature Range
	MB	Mb			
MD5811-d256-V3Q18	32	256	48-pin TSOP-I		Commercial
MD5811-d256-V3Q18-X					Extended
MD5811-d256-V3Q18-P			48-pin TSOP-I	Pb-free	Commercial
MD5811-d256-V3Q18-X-P				Pb-free	Extended
MD5832-d256-V3Q18-X			85-ball FBGA 7x10		Extended
MD5832-d256-V3Q18-X-P				Pb-free	Extended
MD5832-d00-DAISY	00	000	85-ball FBGA 7x10 Daisy-Chain		Daisy-chain format for package reliability testing
MD5811-d256-MECH	00	000	48-pin TSOP-I		Mechanical sample
MD5832-d256-MECH	00	000	85-ball FBGA 7x10		

HOW TO CONTACT US

USA

M-Systems Inc.
8371 Central Ave, Suite A
Newark CA 94560
Phone: +1-510-494-2090
Fax: +1-510-494-5545

Japan

M-Systems Japan Inc.
Asahi Seimei Gotanda Bldg., 3F
5-25-16 Higashi-Gotanda
Shinagawa-ku Tokyo, 141-0022
Phone: +81-3-5423-8101
Fax: +81-3-5423-8102

Taiwan

M-Systems Asia Ltd.
Room B, 13 F, No. 133 Sec. 3
Min Sheng East Road
Taipei, Taiwan
R.O.C.
Tel: +886-2-8770-6226
Fax: +886-2-8770-6295

China

M-Systems China Ltd.
25A International Business Commercial Bldg.
Nanhu Rd., Lou Hu District
Shenzhen, China 518001
Phone: +86-755-2519-4732
Fax: +86-755-2519-4729

Europe

M-Systems Ltd.
7 Atir Yeda St.
Kfar Saba 44425, Israel
Tel: +972-9-764-5000
Fax: +972-3-548-8666

Internet

<http://www.m-sys.com>

General Information

info@m-sys.com

Sales and Technical Information

techsupport@m-sys.com

© 2003 M-Systems Flash Disk Pioneers, Ltd. All rights reserved.

This document is for information use only and is subject to change without prior notice. M-Systems Flash Disk Pioneers Ltd. assumes no responsibility for any errors that may appear in this document. No part of this document may be reproduced, transmitted, transcribed, stored in a retrievable manner or translated into any language or computer language, in any form or by any means, electronic, mechanical, magnetic, optical, chemical, manual or otherwise, without prior written consent of M-Systems.



M-Systems products are not warranted to operate without failure. Accordingly, in any use of the Product in life support systems or other applications where failure could cause injury or loss of life, the Product should only be incorporated in systems designed with appropriate and sufficient redundancy or backup features.

Contact your local M-Systems sales office or distributor, or visit our website at www.m-sys.com to obtain the latest specifications before placing your order.

M-Systems® is a registered trademark. DiskOnChip®, DiskOnChip Millennium®, DiskOnKey®, Smart DiskOnKey® and TrueFFS® are registered trademarks of M-Systems. DiskOnKey MyKey™, FFD™, Fly-By™, iDiskOnChip™, iDOC™, mDiskOnChip™, mDOC™, Mobile DiskOnChip™, SuperMAP™, uDiskOnChip™ and uDOC™ are trademarks of M-Systems. Other product names mentioned in this document may be trademarks or registered trademarks of their respective owners and are hereby acknowledged.

Looking for pricing, stock, or lifecycle information?

Click below to explore more details on WIN SOURCE:

-  [View MD5811-D256-V3Q18-X-P on WIN SOURCE](#)
-  [SanDisk Information](#)

Optimize Your Supply Chain with WIN SOURCE Solutions

-  Global Sourcing Solution
-  Obsolete Management
-  Cost Control Management
-  Shortage Management
-  Alternative Solution
-  Excess Inventory Management