



**THE DATASHEET OF  
MHQ1005P3N0CT000**



Inductors for high frequency circuits  
Multilayer ceramic  
MHQ-P series



## MHQ1005P type



### FEATURES

- Unique ceramic material and configuration allows for the realization of high Q characteristics that are equivalent to that of air core wound inductors.
- Multilayer method allows for a lineup with fine increments of inductance.
- Operating temperature range: -55 to +125°C

### APPLICATION

- Smart phones, tablet terminals, high frequency modules (PAs, VCOs, FEMs , etc.), Bluetooth, W-LAN, UWB, tuners and other high frequency circuits for the mobile communication industry
- Application guides: [Smart phones/tablets](#)

### PART NUMBER CONSTRUCTION

MHQ	1005	P	0N7	B	T	000
Series name	LxWxH dimensions 1.0x0.6x0.5 mm	Characteristics	Inductance (nH)	Inductance tolerance	Packaging style	Internal code

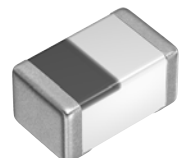

# MHQ1005P type

## CHARACTERISTICS SPECIFICATION TABLE

L (nH)	Tolerance	L measuring frequency (MHz)	Q min.	Q measuring frequency (MHz)	Self-resonant frequency		DC resistance		Rated current (mA)max.	Part No.
					(GHz)min.	(GHz)typ.	( $\Omega$ )max.	( $\Omega$ )typ.		
0.7	$\pm 0.1$ nH	100	—	250	15.0	18.3	0.03	0.01	1200	<a href="#">MHQ1005P0N7BT000</a>
0.7	$\pm 0.2$ nH	100	—	250	15.0	18.3	0.03	0.01	1200	<a href="#">MHQ1005P0N7CT000</a>
0.8	$\pm 0.1$ nH	100	—	250	15.0	18.3	0.03	0.01	1200	<a href="#">MHQ1005P0N8BT000</a>
0.8	$\pm 0.2$ nH	100	—	250	15.0	18.3	0.03	0.01	1200	<a href="#">MHQ1005P0N8CT000</a>
0.9	$\pm 0.1$ nH	100	—	250	15.0	18.6	0.03	0.01	1200	<a href="#">MHQ1005P0N9BT000</a>
0.9	$\pm 0.2$ nH	100	—	250	15.0	18.6	0.03	0.01	1200	<a href="#">MHQ1005P0N9CT000</a>
1.0	$\pm 0.1$ nH	100	—	250	15.0	20.0	0.03	0.01	1200	<a href="#">MHQ1005P1N0BT000</a>
1.0	$\pm 0.2$ nH	100	—	250	15.0	20.0	0.03	0.01	1200	<a href="#">MHQ1005P1N0CT000</a>
1.0	$\pm 0.3$ nH	100	—	250	15.0	20.0	0.03	0.01	1200	<a href="#">MHQ1005P1N0ST000</a>
1.1	$\pm 0.1$ nH	100	—	250	14.0	20.0	0.03	0.02	1200	<a href="#">MHQ1005P1N1BT000</a>
1.1	$\pm 0.2$ nH	100	—	250	14.0	20.0	0.03	0.02	1200	<a href="#">MHQ1005P1N1CT000</a>
1.1	$\pm 0.3$ nH	100	—	250	14.0	20.0	0.03	0.02	1200	<a href="#">MHQ1005P1N1ST000</a>
1.2	$\pm 0.1$ nH	100	—	250	13.0	20.0	0.03	0.01	1200	<a href="#">MHQ1005P1N2BT000</a>
1.2	$\pm 0.2$ nH	100	—	250	13.0	20.0	0.03	0.01	1200	<a href="#">MHQ1005P1N2CT000</a>
1.2	$\pm 0.3$ nH	100	—	250	13.0	20.0	0.03	0.01	1200	<a href="#">MHQ1005P1N2ST000</a>
1.3	$\pm 0.1$ nH	100	—	250	12.0	20.0	0.03	0.01	1200	<a href="#">MHQ1005P1N3BT000</a>
1.3	$\pm 0.2$ nH	100	—	250	12.0	20.0	0.03	0.01	1200	<a href="#">MHQ1005P1N3CT000</a>
1.3	$\pm 0.3$ nH	100	—	250	12.0	20.0	0.03	0.01	1200	<a href="#">MHQ1005P1N3ST000</a>
1.4	$\pm 0.1$ nH	100	23	250	12.0	20.0	0.04	0.02	1000	<a href="#">MHQ1005P1N4BT000</a>
1.4	$\pm 0.2$ nH	100	23	250	12.0	20.0	0.04	0.02	1000	<a href="#">MHQ1005P1N4CT000</a>
1.4	$\pm 0.3$ nH	100	23	250	12.0	20.0	0.04	0.02	1000	<a href="#">MHQ1005P1N4ST000</a>
1.5	$\pm 0.1$ nH	100	23	250	11.0	19.7	0.04	0.02	1000	<a href="#">MHQ1005P1N5BT000</a>
1.5	$\pm 0.2$ nH	100	23	250	11.0	19.7	0.04	0.02	1000	<a href="#">MHQ1005P1N5CT000</a>
1.5	$\pm 0.3$ nH	100	23	250	11.0	19.7	0.04	0.02	1000	<a href="#">MHQ1005P1N5ST000</a>
1.6	$\pm 0.1$ nH	100	23	250	10.0	15.2	0.04	0.02	1000	<a href="#">MHQ1005P1N6BT000</a>
1.6	$\pm 0.2$ nH	100	23	250	10.0	15.2	0.04	0.02	1000	<a href="#">MHQ1005P1N6CT000</a>
1.6	$\pm 0.3$ nH	100	23	250	10.0	15.2	0.04	0.02	1000	<a href="#">MHQ1005P1N6ST000</a>
1.7	$\pm 0.1$ nH	100	23	250	10.0	15.4	0.04	0.02	1000	<a href="#">MHQ1005P1N7BT000</a>
1.7	$\pm 0.2$ nH	100	23	250	10.0	15.4	0.04	0.02	1000	<a href="#">MHQ1005P1N7CT000</a>
1.7	$\pm 0.3$ nH	100	23	250	10.0	15.4	0.04	0.02	1000	<a href="#">MHQ1005P1N7ST000</a>
1.8	$\pm 0.1$ nH	100	23	250	9.0	15.1	0.04	0.03	1000	<a href="#">MHQ1005P1N8BT000</a>
1.8	$\pm 0.2$ nH	100	23	250	9.0	15.1	0.04	0.03	1000	<a href="#">MHQ1005P1N8CT000</a>
1.8	$\pm 0.3$ nH	100	23	250	9.0	15.1	0.04	0.03	1000	<a href="#">MHQ1005P1N8ST000</a>
1.9	$\pm 0.1$ nH	100	23	250	8.0	14.8	0.05	0.03	1000	<a href="#">MHQ1005P1N9BT000</a>
1.9	$\pm 0.2$ nH	100	23	250	8.0	14.8	0.05	0.03	1000	<a href="#">MHQ1005P1N9CT000</a>
1.9	$\pm 0.3$ nH	100	23	250	8.0	14.8	0.05	0.03	1000	<a href="#">MHQ1005P1N9ST000</a>
2.0	$\pm 0.1$ nH	100	23	250	8.0	11.5	0.05	0.03	1000	<a href="#">MHQ1005P2N0BT000</a>
2.0	$\pm 0.2$ nH	100	23	250	8.0	11.5	0.05	0.03	1000	<a href="#">MHQ1005P2N0CT000</a>
2.0	$\pm 0.3$ nH	100	23	250	8.0	11.5	0.05	0.03	1000	<a href="#">MHQ1005P2N0ST000</a>
2.1	$\pm 0.1$ nH	100	23	250	8.0	13.1	0.06	0.04	1000	<a href="#">MHQ1005P2N1BT000</a>
2.1	$\pm 0.2$ nH	100	23	250	8.0	13.1	0.06	0.04	1000	<a href="#">MHQ1005P2N1CT000</a>
2.1	$\pm 0.3$ nH	100	23	250	8.0	13.1	0.06	0.04	1000	<a href="#">MHQ1005P2N1ST000</a>
2.2	$\pm 0.1$ nH	100	23	250	8.0	12.1	0.06	0.04	1000	<a href="#">MHQ1005P2N2BT000</a>
2.2	$\pm 0.2$ nH	100	23	250	8.0	12.1	0.06	0.04	1000	<a href="#">MHQ1005P2N2CT000</a>
2.2	$\pm 0.3$ nH	100	23	250	8.0	12.1	0.06	0.04	1000	<a href="#">MHQ1005P2N2ST000</a>

Short bar residual inductance =0.556nH

### Measurement equipment

Measurement item	Product No.	Manufacturer
L, Q	4291B+16193A	Keysight Technologies
Self-resonant frequency	8720C	Keysight Technologies
DC resistance	Type-7561	Yokogawa

\* Equivalent measurement equipment may be used.

## MHQ1005P type

## CHARACTERISTICS SPECIFICATION TABLE

L (nH)	Tolerance	L measuring frequency (MHz)	Q min.	Q measuring frequency (MHz)	Self-resonant frequency		DC resistance		Rated current (mA)max.	Part No.
					(GHz)min.	(GHz)typ.	( $\Omega$ )max.	( $\Omega$ )typ.		
2.3	$\pm 0.1$ nH	100	23	250	7.0	10.5	0.07	0.05	1000	<a href="#">MHQ1005P2N3BT000</a>
2.3	$\pm 0.2$ nH	100	23	250	7.0	10.5	0.07	0.05	1000	<a href="#">MHQ1005P2N3CT000</a>
2.3	$\pm 0.3$ nH	100	23	250	7.0	10.5	0.07	0.05	1000	<a href="#">MHQ1005P2N3ST000</a>
2.4	$\pm 0.1$ nH	100	23	250	6.5	9.8	0.06	0.04	1000	<a href="#">MHQ1005P2N4BT000</a>
2.4	$\pm 0.2$ nH	100	23	250	6.5	9.8	0.06	0.04	1000	<a href="#">MHQ1005P2N4CT000</a>
2.4	$\pm 0.3$ nH	100	23	250	6.5	9.8	0.06	0.04	1000	<a href="#">MHQ1005P2N4ST000</a>
2.5	$\pm 0.1$ nH	100	23	250	6.5	10.3	0.07	0.05	900	<a href="#">MHQ1005P2N5BT000</a>
2.5	$\pm 0.2$ nH	100	23	250	6.5	10.3	0.07	0.05	900	<a href="#">MHQ1005P2N5CT000</a>
2.5	$\pm 0.3$ nH	100	23	250	6.5	10.3	0.07	0.05	900	<a href="#">MHQ1005P2N5ST000</a>
2.6	$\pm 0.1$ nH	100	23	250	6.5	10.1	0.07	0.05	900	<a href="#">MHQ1005P2N6BT000</a>
2.6	$\pm 0.2$ nH	100	23	250	6.5	10.1	0.07	0.05	900	<a href="#">MHQ1005P2N6CT000</a>
2.6	$\pm 0.3$ nH	100	23	250	6.5	10.1	0.07	0.05	900	<a href="#">MHQ1005P2N6ST000</a>
2.7	$\pm 0.1$ nH	100	23	250	6.5	9.6	0.07	0.04	900	<a href="#">MHQ1005P2N7BT000</a>
2.7	$\pm 0.2$ nH	100	23	250	6.5	9.6	0.07	0.04	900	<a href="#">MHQ1005P2N7CT000</a>
2.7	$\pm 0.3$ nH	100	23	250	6.5	9.6	0.07	0.04	900	<a href="#">MHQ1005P2N7ST000</a>
2.8	$\pm 0.1$ nH	100	23	250	6.5	10.3	0.08	0.05	900	<a href="#">MHQ1005P2N8BT000</a>
2.8	$\pm 0.2$ nH	100	23	250	6.5	10.3	0.08	0.05	900	<a href="#">MHQ1005P2N8CT000</a>
2.8	$\pm 0.3$ nH	100	23	250	6.5	10.3	0.08	0.05	900	<a href="#">MHQ1005P2N8ST000</a>
2.9	$\pm 0.1$ nH	100	23	250	6.5	9.9	0.08	0.05	900	<a href="#">MHQ1005P2N9BT000</a>
2.9	$\pm 0.2$ nH	100	23	250	6.5	9.9	0.08	0.05	900	<a href="#">MHQ1005P2N9CT000</a>
2.9	$\pm 0.3$ nH	100	23	250	6.5	9.9	0.08	0.05	900	<a href="#">MHQ1005P2N9ST000</a>
3.0	$\pm 0.1$ nH	100	23	250	6.0	9.4	0.08	0.06	900	<a href="#">MHQ1005P3N0BT000</a>
3.0	$\pm 0.2$ nH	100	23	250	6.0	9.4	0.08	0.06	900	<a href="#">MHQ1005P3N0CT000</a>
3.0	$\pm 0.3$ nH	100	23	250	6.0	9.4	0.08	0.06	900	<a href="#">MHQ1005P3N0ST000</a>
3.1	$\pm 0.1$ nH	100	23	250	6.0	10.3	0.09	0.06	900	<a href="#">MHQ1005P3N1BT000</a>
3.1	$\pm 0.2$ nH	100	23	250	6.0	10.3	0.09	0.06	900	<a href="#">MHQ1005P3N1CT000</a>
3.1	$\pm 0.3$ nH	100	23	250	6.0	10.3	0.09	0.06	900	<a href="#">MHQ1005P3N1ST000</a>
3.2	$\pm 0.1$ nH	100	23	250	6.0	10.0	0.09	0.07	900	<a href="#">MHQ1005P3N2BT000</a>
3.2	$\pm 0.2$ nH	100	23	250	6.0	10.0	0.09	0.07	900	<a href="#">MHQ1005P3N2CT000</a>
3.2	$\pm 0.3$ nH	100	23	250	6.0	10.0	0.09	0.07	900	<a href="#">MHQ1005P3N2ST000</a>
3.3	$\pm 0.1$ nH	100	23	250	6.0	9.0	0.08	0.06	900	<a href="#">MHQ1005P3N3BT000</a>
3.3	$\pm 0.2$ nH	100	23	250	6.0	9.0	0.08	0.06	900	<a href="#">MHQ1005P3N3CT000</a>
3.3	$\pm 0.3$ nH	100	23	250	6.0	9.0	0.08	0.06	900	<a href="#">MHQ1005P3N3ST000</a>
3.4	$\pm 0.1$ nH	100	23	250	6.0	9.0	0.09	0.06	900	<a href="#">MHQ1005P3N4BT000</a>
3.4	$\pm 0.2$ nH	100	23	250	6.0	9.0	0.09	0.06	900	<a href="#">MHQ1005P3N4CT000</a>
3.4	$\pm 0.3$ nH	100	23	250	6.0	9.0	0.09	0.06	900	<a href="#">MHQ1005P3N4ST000</a>
3.5	$\pm 0.1$ nH	100	23	250	5.8	8.8	0.09	0.07	900	<a href="#">MHQ1005P3N5BT000</a>
3.5	$\pm 0.2$ nH	100	23	250	5.8	8.8	0.09	0.07	900	<a href="#">MHQ1005P3N5CT000</a>
3.5	$\pm 0.3$ nH	100	23	250	5.8	8.8	0.09	0.07	900	<a href="#">MHQ1005P3N5ST000</a>
3.6	$\pm 0.1$ nH	100	23	250	5.5	8.4	0.09	0.07	900	<a href="#">MHQ1005P3N6BT000</a>
3.6	$\pm 0.2$ nH	100	23	250	5.5	8.4	0.09	0.07	900	<a href="#">MHQ1005P3N6CT000</a>
3.6	$\pm 0.3$ nH	100	23	250	5.5	8.4	0.09	0.07	900	<a href="#">MHQ1005P3N6ST000</a>
3.7	$\pm 0.1$ nH	100	23	250	5.5	8.5	0.10	0.08	900	<a href="#">MHQ1005P3N7BT000</a>
3.7	$\pm 0.2$ nH	100	23	250	5.5	8.5	0.10	0.08	900	<a href="#">MHQ1005P3N7CT000</a>
3.7	$\pm 0.3$ nH	100	23	250	5.5	8.5	0.10	0.08	900	<a href="#">MHQ1005P3N7ST000</a>

· Short bar residual inductance =0.556nH

## Measurement equipment

Measurement item	Product No.	Manufacturer
L, Q	4291B+16193A	Keysight Technologies
Self-resonant frequency	8720C	Keysight Technologies
DC resistance	Type-7561	Yokogawa

\* Equivalent measurement equipment may be used.

## MHQ1005P type

## CHARACTERISTICS SPECIFICATION TABLE

L (nH)	Tolerance	L measuring frequency (MHz)	Q min.	Q measuring frequency (MHz)	Self-resonant frequency		DC resistance		Rated current (mA)max.	Part No.
					(GHz)min.	(GHz)typ.	( $\Omega$ )max.	( $\Omega$ )typ.		
3.8	$\pm 0.1$ nH	100	23	250	5.0	7.9	0.10	0.07	900	<a href="#">MHQ1005P3N8BT000</a>
3.8	$\pm 0.2$ nH	100	23	250	5.0	7.9	0.10	0.07	900	<a href="#">MHQ1005P3N8CT000</a>
3.8	$\pm 0.3$ nH	100	23	250	5.0	7.9	0.10	0.07	900	<a href="#">MHQ1005P3N8ST000</a>
3.9	$\pm 0.1$ nH	100	23	250	5.0	7.7	0.09	0.07	900	<a href="#">MHQ1005P3N9BT000</a>
3.9	$\pm 0.2$ nH	100	23	250	5.0	7.7	0.09	0.07	900	<a href="#">MHQ1005P3N9CT000</a>
3.9	$\pm 0.3$ nH	100	23	250	5.0	7.7	0.09	0.07	900	<a href="#">MHQ1005P3N9ST000</a>
4.1	$\pm 0.1$ nH	100	23	250	5.0	7.7	0.10	0.07	800	<a href="#">MHQ1005P4N1BT000</a>
4.1	$\pm 0.2$ nH	100	23	250	5.0	7.7	0.10	0.07	800	<a href="#">MHQ1005P4N1CT000</a>
4.1	$\pm 0.3$ nH	100	23	250	5.0	7.7	0.10	0.07	800	<a href="#">MHQ1005P4N1ST000</a>
4.3	$\pm 0.1$ nH	100	23	250	5.0	7.1	0.10	0.08	800	<a href="#">MHQ1005P4N3BT000</a>
4.3	$\pm 0.2$ nH	100	23	250	5.0	7.1	0.10	0.08	800	<a href="#">MHQ1005P4N3CT000</a>
4.3	$\pm 0.3$ nH	100	23	250	5.0	7.1	0.10	0.08	800	<a href="#">MHQ1005P4N3ST000</a>
4.7	$\pm 0.1$ nH	100	23	250	5.0	7.7	0.11	0.08	800	<a href="#">MHQ1005P4N7BT000</a>
4.7	$\pm 0.2$ nH	100	23	250	5.0	7.7	0.11	0.08	800	<a href="#">MHQ1005P4N7CT000</a>
4.7	$\pm 0.3$ nH	100	23	250	5.0	7.7	0.11	0.08	800	<a href="#">MHQ1005P4N7ST000</a>
5.1	$\pm 0.1$ nH	100	23	250	4.5	7.2	0.12	0.09	800	<a href="#">MHQ1005P5N1BT000</a>
5.1	$\pm 0.2$ nH	100	23	250	4.5	7.2	0.12	0.09	800	<a href="#">MHQ1005P5N1CT000</a>
5.1	$\pm 0.3$ nH	100	23	250	4.5	7.2	0.12	0.09	800	<a href="#">MHQ1005P5N1ST000</a>
5.6	$\pm 0.1$ nH	100	23	250	4.5	6.5	0.13	0.10	800	<a href="#">MHQ1005P5N6BT000</a>
5.6	$\pm 0.2$ nH	100	23	250	4.5	6.5	0.13	0.10	800	<a href="#">MHQ1005P5N6CT000</a>
5.6	$\pm 0.3$ nH	100	23	250	4.5	6.5	0.13	0.10	800	<a href="#">MHQ1005P5N6ST000</a>
5.8	$\pm 0.1$ nH	100	23	250	4.0	5.9	0.13	0.09	700	<a href="#">MHQ1005P5N8BT000</a>
5.8	$\pm 0.2$ nH	100	23	250	4.0	5.9	0.13	0.09	700	<a href="#">MHQ1005P5N8CT000</a>
5.8	$\pm 0.3$ nH	100	23	250	4.0	5.9	0.13	0.09	700	<a href="#">MHQ1005P5N8ST000</a>
6.2	$\pm 0.1$ nH	100	23	250	4.0	5.9	0.13	0.09	700	<a href="#">MHQ1005P6N2BT000</a>
6.2	$\pm 0.2$ nH	100	23	250	4.0	5.9	0.13	0.09	700	<a href="#">MHQ1005P6N2CT000</a>
6.2	$\pm 0.3$ nH	100	23	250	4.0	5.9	0.13	0.09	700	<a href="#">MHQ1005P6N2ST000</a>
6.8	$\pm 2\%$	100	23	250	4.0	5.8	0.14	0.10	700	<a href="#">MHQ1005P6N8GT000</a>
6.8	$\pm 3\%$	100	23	250	4.0	5.8	0.14	0.10	700	<a href="#">MHQ1005P6N8HT000</a>
6.8	$\pm 5\%$	100	23	250	4.0	5.8	0.14	0.10	700	<a href="#">MHQ1005P6N8JT000</a>
7.3	$\pm 2\%$	100	23	250	4.0	5.7	0.17	0.13	600	<a href="#">MHQ1005P7N3GT000</a>
7.3	$\pm 3\%$	100	23	250	4.0	5.7	0.17	0.13	600	<a href="#">MHQ1005P7N3HT000</a>
7.3	$\pm 5\%$	100	23	250	4.0	5.7	0.17	0.13	600	<a href="#">MHQ1005P7N3JT000</a>
7.5	$\pm 2\%$	100	23	250	4.0	5.6	0.16	0.12	600	<a href="#">MHQ1005P7N5GT000</a>
7.5	$\pm 3\%$	100	23	250	4.0	5.6	0.16	0.12	600	<a href="#">MHQ1005P7N5HT000</a>
7.5	$\pm 5\%$	100	23	250	4.0	5.6	0.16	0.12	600	<a href="#">MHQ1005P7N5JT000</a>
8.2	$\pm 2\%$	100	23	250	3.6	4.9	0.16	0.12	550	<a href="#">MHQ1005P8N2GT000</a>
8.2	$\pm 3\%$	100	23	250	3.6	4.9	0.16	0.12	550	<a href="#">MHQ1005P8N2HT000</a>
8.2	$\pm 5\%$	100	23	250	3.6	4.9	0.16	0.12	550	<a href="#">MHQ1005P8N2JT000</a>
8.7	$\pm 2\%$	100	23	250	3.5	4.7	0.17	0.13	550	<a href="#">MHQ1005P8N7GT000</a>
8.7	$\pm 3\%$	100	23	250	3.5	4.7	0.17	0.13	550	<a href="#">MHQ1005P8N7HT000</a>
8.7	$\pm 5\%$	100	23	250	3.5	4.7	0.17	0.13	550	<a href="#">MHQ1005P8N7JT000</a>
9.1	$\pm 2\%$	100	23	250	3.4	4.5	0.17	0.13	550	<a href="#">MHQ1005P9N1GT000</a>
9.1	$\pm 3\%$	100	23	250	3.4	4.5	0.17	0.13	550	<a href="#">MHQ1005P9N1HT000</a>
9.1	$\pm 5\%$	100	23	250	3.4	4.5	0.17	0.13	550	<a href="#">MHQ1005P9N1JT000</a>

· Short bar residual inductance =0.556nH

## Measurement equipment

Measurement item	Product No.	Manufacturer
L, Q	4291B+16193A	Keysight Technologies
Self-resonant frequency	8720C	Keysight Technologies
DC resistance	Type-7561	Yokogawa

\* Equivalent measurement equipment may be used.

## MHQ1005P type

## CHARACTERISTICS SPECIFICATION TABLE

L (nH)	Tolerance	L measuring frequency (MHz)	Q min.	Q measuring frequency (MHz)	Self-resonant frequency		DC resistance		Rated current (mA)max.	Part No.
					(GHz)min.	(GHz)typ.	( $\Omega$ )max.	( $\Omega$ )typ.		
9.5	±2%	100	23	250	3.3	4.7	0.21	0.16	500	<a href="#">MHQ1005P9N5GT000</a>
9.5	±3%	100	23	250	3.3	4.7	0.21	0.16	500	<a href="#">MHQ1005P9N5HT000</a>
9.5	±5%	100	23	250	3.3	4.7	0.21	0.16	500	<a href="#">MHQ1005P9N5JT000</a>
10	±2%	100	23	250	3.3	4.6	0.19	0.15	500	<a href="#">MHQ1005P10NGT000</a>
10	±3%	100	23	250	3.3	4.6	0.19	0.15	500	<a href="#">MHQ1005P10NHT000</a>
10	±5%	100	23	250	3.3	4.6	0.19	0.15	500	<a href="#">MHQ1005P10NJT000</a>
11	±2%	100	23	250	3.0	4.2	0.24	0.20	450	<a href="#">MHQ1005P11NGT000</a>
11	±3%	100	23	250	3.0	4.2	0.24	0.20	450	<a href="#">MHQ1005P11NHT000</a>
11	±5%	100	23	250	3.0	4.2	0.24	0.20	450	<a href="#">MHQ1005P11NJT000</a>
12	±2%	100	23	250	2.8	3.8	0.24	0.19	450	<a href="#">MHQ1005P12NGT000</a>
12	±3%	100	23	250	2.8	3.8	0.24	0.19	450	<a href="#">MHQ1005P12NHT000</a>
12	±5%	100	23	250	2.8	3.8	0.24	0.19	450	<a href="#">MHQ1005P12NJT000</a>
13	±2%	100	23	250	2.5	3.5	0.26	0.20	420	<a href="#">MHQ1005P13NGT000</a>
13	±3%	100	23	250	2.5	3.5	0.26	0.20	420	<a href="#">MHQ1005P13NHT000</a>
13	±5%	100	23	250	2.5	3.5	0.26	0.20	420	<a href="#">MHQ1005P13NJT000</a>
15	±2%	100	23	250	2.3	3.2	0.28	0.22	400	<a href="#">MHQ1005P15NGT000</a>
15	±3%	100	23	250	2.3	3.2	0.28	0.22	400	<a href="#">MHQ1005P15NHT000</a>
15	±5%	100	23	250	2.3	3.2	0.28	0.22	400	<a href="#">MHQ1005P15NJT000</a>
16	±2%	100	20	250	2.3	3.5	0.80	0.57	260	<a href="#">MHQ1005P16NGT000</a>
16	±3%	100	20	250	2.3	3.5	0.80	0.57	260	<a href="#">MHQ1005P16NHT000</a>
16	±5%	100	20	250	2.3	3.5	0.80	0.57	260	<a href="#">MHQ1005P16NJT000</a>
18	±2%	100	22	250	2.3	3.4	0.80	0.48	260	<a href="#">MHQ1005P18NGT000</a>
18	±3%	100	22	250	2.3	3.4	0.80	0.48	260	<a href="#">MHQ1005P18NHT000</a>
18	±5%	100	22	250	2.3	3.4	0.80	0.48	260	<a href="#">MHQ1005P18NJT000</a>
19	±2%	100	20	250	2.3	3.2	0.80	0.46	260	<a href="#">MHQ1005P19NGT000</a>
19	±3%	100	20	250	2.3	3.2	0.80	0.46	260	<a href="#">MHQ1005P19NHT000</a>
19	±5%	100	20	250	2.3	3.2	0.80	0.46	260	<a href="#">MHQ1005P19NJT000</a>
20	±2%	100	20	250	2.1	3.1	1.10	0.46	260	<a href="#">MHQ1005P20NGT000</a>
20	±3%	100	20	250	2.1	3.1	1.10	0.46	260	<a href="#">MHQ1005P20NHT000</a>
20	±5%	100	20	250	2.1	3.1	1.10	0.46	260	<a href="#">MHQ1005P20NJT000</a>
22	±2%	100	20	250	2.1	2.9	1.10	0.66	230	<a href="#">MHQ1005P22NGT000</a>
22	±3%	100	20	250	2.1	2.9	1.10	0.66	230	<a href="#">MHQ1005P22NHT000</a>
22	±5%	100	20	250	2.1	2.9	1.10	0.66	230	<a href="#">MHQ1005P22NJT000</a>
23	±2%	100	22	250	2.0	2.9	1.10	0.62	230	<a href="#">MHQ1005P23NGT000</a>
23	±3%	100	22	250	2.0	2.9	1.10	0.62	230	<a href="#">MHQ1005P23NHT000</a>
23	±5%	100	22	250	2.0	2.9	1.10	0.62	230	<a href="#">MHQ1005P23NJT000</a>
24	±2%	100	20	250	2.0	2.8	1.20	0.55	230	<a href="#">MHQ1005P24NGT000</a>
24	±3%	100	20	250	2.0	2.8	1.20	0.55	230	<a href="#">MHQ1005P24NHT000</a>
24	±5%	100	20	250	2.0	2.8	1.20	0.55	230	<a href="#">MHQ1005P24NJT000</a>
27	±2%	100	20	250	1.7	2.6	1.30	0.66	230	<a href="#">MHQ1005P27NGT000</a>
27	±3%	100	20	250	1.7	2.6	1.30	0.66	230	<a href="#">MHQ1005P27NHT000</a>
27	±5%	100	20	250	1.7	2.6	1.30	0.66	230	<a href="#">MHQ1005P27NJT000</a>
30	±2%	100	20	250	1.7	2.4	1.30	0.80	220	<a href="#">MHQ1005P30NGT000</a>
30	±3%	100	20	250	1.7	2.4	1.30	0.80	220	<a href="#">MHQ1005P30NHT000</a>
30	±5%	100	20	250	1.7	2.4	1.30	0.80	220	<a href="#">MHQ1005P30NJT000</a>

· Short bar residual inductance =0.556nH

## Measurement equipment

Measurement item	Product No.	Manufacturer
L, Q	4291B+16193A	Keysight Technologies
Self-resonant frequency	8720C	Keysight Technologies
DC resistance	Type-7561	Yokogawa

\* Equivalent measurement equipment may be used.

## MHQ1005P type

## CHARACTERISTICS SPECIFICATION TABLE

L (nH)	Tolerance	L measuring frequency (MHz)	Q min.	Q measuring frequency (MHz)	Self-resonant frequency		DC resistance		Rated current (mA)max.	Part No.
					(GHz)min.	(GHz)typ.	( $\Omega$ )max.	( $\Omega$ )typ.		
33	±2%	100	20	250	1.6	2.3	1.50	0.74	220	<a href="#">MHQ1005P33NGT000</a>
33	±3%	100	20	250	1.6	2.3	1.50	0.74	220	<a href="#">MHQ1005P33NHT000</a>
33	±5%	100	20	250	1.6	2.3	1.50	0.74	220	<a href="#">MHQ1005P33NJT000</a>
36	±2%	100	20	250	1.6	2.2	1.50	0.92	190	<a href="#">MHQ1005P36NGT000</a>
36	±3%	100	20	250	1.6	2.2	1.50	0.92	190	<a href="#">MHQ1005P36NHT000</a>
36	±5%	100	20	250	1.6	2.2	1.50	0.92	190	<a href="#">MHQ1005P36NJT000</a>
39	±2%	100	20	250	1.4	2.1	1.50	0.95	190	<a href="#">MHQ1005P39NGT000</a>
39	±3%	100	20	250	1.4	2.1	1.50	0.95	190	<a href="#">MHQ1005P39NHT000</a>
39	±5%	100	20	250	1.4	2.1	1.50	0.95	190	<a href="#">MHQ1005P39NJT000</a>
40	±2%	100	20	250	1.4	2.1	1.50	1.12	190	<a href="#">MHQ1005P40NGT000</a>
40	±3%	100	20	250	1.4	2.1	1.50	1.12	190	<a href="#">MHQ1005P40NHT000</a>
40	±5%	100	20	250	1.4	2.1	1.50	1.12	190	<a href="#">MHQ1005P40NJT000</a>
43	±2%	100	22	250	1.4	2.0	1.60	1.06	190	<a href="#">MHQ1005P43NGT000</a>
43	±3%	100	22	250	1.4	2.0	1.60	1.06	190	<a href="#">MHQ1005P43NHT000</a>
43	±5%	100	22	250	1.4	2.0	1.60	1.06	190	<a href="#">MHQ1005P43NJT000</a>
47	±2%	100	22	250	1.3	1.9	1.60	1.09	190	<a href="#">MHQ1005P47NGT000</a>
47	±3%	100	22	250	1.3	1.9	1.60	1.09	190	<a href="#">MHQ1005P47NHT000</a>
47	±5%	100	22	250	1.3	1.9	1.60	1.09	190	<a href="#">MHQ1005P47NJT000</a>
51	±2%	100	22	250	1.3	1.8	1.80	1.17	190	<a href="#">MHQ1005P51NGT000</a>
51	±3%	100	22	250	1.3	1.8	1.80	1.17	190	<a href="#">MHQ1005P51NHT000</a>
51	±5%	100	22	250	1.3	1.8	1.80	1.17	190	<a href="#">MHQ1005P51NJT000</a>
56	±2%	100	22	250	1.2	1.8	1.80	1.22	180	<a href="#">MHQ1005P56NGT000</a>
56	±3%	100	22	250	1.2	1.8	1.80	1.22	180	<a href="#">MHQ1005P56NHT000</a>
56	±5%	100	22	250	1.2	1.8	1.80	1.22	180	<a href="#">MHQ1005P56NJT000</a>
62	±2%	100	22	250	1.1	1.6	1.90	1.36	180	<a href="#">MHQ1005P62NGT000</a>
62	±3%	100	22	250	1.1	1.6	1.90	1.36	180	<a href="#">MHQ1005P62NHT000</a>
62	±5%	100	22	250	1.1	1.6	1.90	1.36	180	<a href="#">MHQ1005P62NJT000</a>
68	±2%	100	22	250	1.1	1.6	2.00	1.43	160	<a href="#">MHQ1005P68NGT000</a>
68	±3%	100	22	250	1.1	1.6	2.00	1.43	160	<a href="#">MHQ1005P68NHT000</a>
68	±5%	100	22	250	1.1	1.6	2.00	1.43	160	<a href="#">MHQ1005P68NJT000</a>
72	±2%	100	22	250	1.1	1.5	2.20	1.62	160	<a href="#">MHQ1005P72NGT000</a>
72	±3%	100	22	250	1.1	1.5	2.20	1.62	160	<a href="#">MHQ1005P72NHT000</a>
72	±5%	100	22	250	1.1	1.5	2.20	1.62	160	<a href="#">MHQ1005P72NJT000</a>
75	±2%	100	22	250	1.1	1.5	2.20	1.53	160	<a href="#">MHQ1005P75NGT000</a>
75	±3%	100	22	250	1.1	1.5	2.20	1.53	160	<a href="#">MHQ1005P75NHT000</a>
75	±5%	100	22	250	1.1	1.5	2.20	1.53	160	<a href="#">MHQ1005P75NJT000</a>
82	±2%	100	22	250	0.9	1.5	2.30	1.61	160	<a href="#">MHQ1005P82NGT000</a>
82	±3%	100	22	250	0.9	1.5	2.30	1.61	160	<a href="#">MHQ1005P82NHT000</a>
82	±5%	100	22	250	0.9	1.5	2.30	1.61	160	<a href="#">MHQ1005P82NJT000</a>
91	±2%	100	23	250	0.9	1.4	2.30	1.78	160	<a href="#">MHQ1005P91NGT000</a>
91	±3%	100	23	250	0.9	1.4	2.30	1.78	160	<a href="#">MHQ1005P91NHT000</a>
91	±5%	100	23	250	0.9	1.4	2.30	1.78	160	<a href="#">MHQ1005P91NJT000</a>
100	±2%	100	23	250	0.9	1.2	2.50	1.80	150	<a href="#">MHQ1005PR10GT000</a>
100	±3%	100	23	250	0.9	1.2	2.50	1.80	150	<a href="#">MHQ1005PR10HT000</a>
100	±5%	100	23	250	0.9	1.2	2.50	1.80	150	<a href="#">MHQ1005PR10JT000</a>

· Short bar residual inductance =0.556nH

## Measurement equipment

Measurement item	Product No.	Manufacturer
L, Q	4291B+16193A	Keysight Technologies
Self-resonant frequency	8720C	Keysight Technologies
DC resistance	Type-7561	Yokogawa

\* Equivalent measurement equipment may be used.

## MHQ1005P type

## CHARACTERISTICS SPECIFICATION TABLE

L	L measuring frequency		Q	Q measuring frequency		Self-resonant frequency		DC resistance		Rated current	Part No.
	(nH)	Tolerance		(MHz)	min.	(MHz)	(GHz)min.	(GHz)typ.	( $\Omega$ )max.		
110	$\pm 2\%$	100	22	250	0.8	1.2	2.70	1.98	150	<a href="#">MHQ1005PR11GT000</a>	
110	$\pm 3\%$	100	22	250	0.8	1.2	2.70	1.98	150	<a href="#">MHQ1005PR11HT000</a>	
110	$\pm 5\%$	100	22	250	0.8	1.2	2.70	1.98	150	<a href="#">MHQ1005PR11JT000</a>	
120	$\pm 2\%$	100	22	250	0.8	1.2	2.70	1.81	140	<a href="#">MHQ1005PR12GT000</a>	
120	$\pm 3\%$	100	22	250	0.8	1.2	2.70	1.81	140	<a href="#">MHQ1005PR12HT000</a>	
120	$\pm 5\%$	100	22	250	0.8	1.2	2.70	1.81	140	<a href="#">MHQ1005PR12JT000</a>	
130	$\pm 2\%$	100	22	250	0.8	1.1	2.90	2.18	110	<a href="#">MHQ1005PR13GT000</a>	
130	$\pm 3\%$	100	22	250	0.8	1.1	2.90	2.18	110	<a href="#">MHQ1005PR13HT000</a>	
130	$\pm 5\%$	100	22	250	0.8	1.1	2.90	2.18	110	<a href="#">MHQ1005PR13JT000</a>	
150	$\pm 2\%$	100	22	250	0.8	1.0	3.00	2.03	110	<a href="#">MHQ1005PR15GT000</a>	
150	$\pm 3\%$	100	22	250	0.8	1.0	3.00	2.03	110	<a href="#">MHQ1005PR15HT000</a>	
150	$\pm 5\%$	100	22	250	0.8	1.0	3.00	2.03	110	<a href="#">MHQ1005PR15JT000</a>	
160	$\pm 2\%$	100	22	250	0.7	1.0	5.80	4.79	90	<a href="#">MHQ1005PR16GT000</a>	
160	$\pm 3\%$	100	22	250	0.7	1.0	5.80	4.79	90	<a href="#">MHQ1005PR16HT000</a>	
160	$\pm 5\%$	100	22	250	0.7	1.0	5.80	4.79	90	<a href="#">MHQ1005PR16JT000</a>	
180	$\pm 2\%$	100	18	250	0.6	0.9	6.00	4.86	90	<a href="#">MHQ1005PR18GT000</a>	
180	$\pm 3\%$	100	18	250	0.6	0.9	6.00	4.86	90	<a href="#">MHQ1005PR18HT000</a>	
180	$\pm 5\%$	100	18	250	0.6	0.9	6.00	4.86	90	<a href="#">MHQ1005PR18JT000</a>	
200	$\pm 2\%$	100	18	250	0.6	0.9	6.20	5.06	80	<a href="#">MHQ1005PR20GT000</a>	
200	$\pm 3\%$	100	18	250	0.6	0.9	6.20	5.06	80	<a href="#">MHQ1005PR20HT000</a>	
200	$\pm 5\%$	100	18	250	0.6	0.9	6.20	5.06	80	<a href="#">MHQ1005PR20JT000</a>	
220	$\pm 2\%$	100	18	250	0.6	0.8	6.60	5.38	80	<a href="#">MHQ1005PR22GT000</a>	
220	$\pm 3\%$	100	18	250	0.6	0.8	6.60	5.38	80	<a href="#">MHQ1005PR22HT000</a>	
220	$\pm 5\%$	100	18	250	0.6	0.8	6.60	5.38	80	<a href="#">MHQ1005PR22JT000</a>	
240	$\pm 2\%$	100	18	250	0.6	0.9	6.80	5.58	80	<a href="#">MHQ1005PR24GT000</a>	
240	$\pm 3\%$	100	18	250	0.6	0.9	6.80	5.58	80	<a href="#">MHQ1005PR24HT000</a>	
240	$\pm 5\%$	100	18	250	0.6	0.9	6.80	5.58	80	<a href="#">MHQ1005PR24JT000</a>	
270	$\pm 2\%$	100	18	250	0.6	0.9	7.00	5.74	80	<a href="#">MHQ1005PR27GT000</a>	
270	$\pm 3\%$	100	18	250	0.6	0.9	7.00	5.74	80	<a href="#">MHQ1005PR27HT000</a>	
270	$\pm 5\%$	100	18	250	0.6	0.9	7.00	5.74	80	<a href="#">MHQ1005PR27JT000</a>	
300	$\pm 2\%$	50	13	100	0.48	0.7	7.80	6.38	80	<a href="#">MHQ1005PR30GT000</a>	
300	$\pm 3\%$	50	13	100	0.48	0.7	7.80	6.38	80	<a href="#">MHQ1005PR30HT000</a>	
300	$\pm 5\%$	50	13	100	0.48	0.7	7.80	6.38	80	<a href="#">MHQ1005PR30JT000</a>	
330	$\pm 2\%$	50	13	100	0.48	0.67	8.20	6.64	80	<a href="#">MHQ1005PR33GT000</a>	
330	$\pm 3\%$	50	13	100	0.48	0.67	8.20	6.64	80	<a href="#">MHQ1005PR33HT000</a>	
330	$\pm 5\%$	50	13	100	0.48	0.67	8.20	6.64	80	<a href="#">MHQ1005PR33JT000</a>	
360	$\pm 2\%$	50	13	100	0.45	0.65	8.40	6.91	80	<a href="#">MHQ1005PR36GT000</a>	
360	$\pm 3\%$	50	13	100	0.45	0.65	8.40	6.91	80	<a href="#">MHQ1005PR36HT000</a>	
360	$\pm 5\%$	50	13	100	0.45	0.65	8.40	6.91	80	<a href="#">MHQ1005PR36JT000</a>	
390	$\pm 2\%$	50	13	100	0.45	0.64	8.80	7.20	70	<a href="#">MHQ1005PR39GT000</a>	
390	$\pm 3\%$	50	13	100	0.45	0.64	8.80	7.20	70	<a href="#">MHQ1005PR39HT000</a>	
390	$\pm 5\%$	50	13	100	0.45	0.64	8.80	7.20	70	<a href="#">MHQ1005PR39JT000</a>	
430	$\pm 2\%$	50	13	100	0.38	0.56	9.60	7.88	70	<a href="#">MHQ1005PR43GT000</a>	
430	$\pm 3\%$	50	13	100	0.38	0.56	9.60	7.88	70	<a href="#">MHQ1005PR43HT000</a>	
430	$\pm 5\%$	50	13	100	0.38	0.56	9.60	7.88	70	<a href="#">MHQ1005PR43JT000</a>	
470	$\pm 2\%$	50	13	100	0.38	0.59	9.60	7.90	70	<a href="#">MHQ1005PR47GT000</a>	
470	$\pm 3\%$	50	13	100	0.38	0.59	9.60	7.90	70	<a href="#">MHQ1005PR47HT000</a>	
470	$\pm 5\%$	50	13	100	0.38	0.59	9.60	7.90	70	<a href="#">MHQ1005PR47JT000</a>	
510	$\pm 2\%$	50	13	100	0.36	0.52	10.2	8.44	70	<a href="#">MHQ1005PR51GT000</a>	
510	$\pm 3\%$	50	13	100	0.36	0.52	10.2	8.44	70	<a href="#">MHQ1005PR51HT000</a>	
510	$\pm 5\%$	50	13	100	0.36	0.52	10.2	8.44	70	<a href="#">MHQ1005PR51JT000</a>	
560	$\pm 2\%$	50	13	100	0.36	0.51	10.6	8.78	70	<a href="#">MHQ1005PR56GT000</a>	
560	$\pm 3\%$	50	13	100	0.36	0.51	10.6	8.78	70	<a href="#">MHQ1005PR56HT000</a>	
560	$\pm 5\%$	50	13	100	0.36	0.51	10.6	8.78	70	<a href="#">MHQ1005PR56JT000</a>	

· Short bar residual inductance =0.556nH

## Measurement equipment

Measurement item	Product No.	Manufacturer
L, Q	4291B+16193A	Keysight Technologies
Self-resonant frequency	8720C	Keysight Technologies
DC resistance	Type-7561	Yokogawa

\* Equivalent measurement equipment may be used.

⚠ Please be sure to request delivery specifications that provide further details on the features and specifications of the products for proper and safe use. (7/17)  
Please note that the contents may change without any prior notice due to reasons such as upgrading.

20181220

inductor\_commercial\_high-frequency\_mhq1005p\_en

## MHQ1005P type

## ■ L, Q FREQUENCY CHARACTERISTICS TABLE

L(nH)typ.		Q typ.					Part No.				
500MHz	800MHz	1.8GHz	2.0GHz	2.4GHz	500MHz	800MHz	1.8GHz	2.0GHz	2.4GHz		
0.7	0.7	0.7	0.7	0.7	71min.	90min.	139min.	148min.	177min.	<a href="#">MHQ1005P0N7BT000</a>	
0.7	0.7	0.7	0.7	0.7	71min.	90min.	139min.	148min.	177min.	<a href="#">MHQ1005P0N7CT000</a>	
0.8	0.8	0.8	0.8	0.8	71min.	90min.	139min.	148min.	177min.	<a href="#">MHQ1005P0N8BT000</a>	
0.8	0.8	0.8	0.8	0.8	71min.	90min.	139min.	148min.	177min.	<a href="#">MHQ1005P0N8CT000</a>	
0.9	0.9	0.9	0.9	0.9	71min.	90min.	139min.	148min.	177min.	<a href="#">MHQ1005P0N9BT000</a>	
0.9	0.9	0.9	0.9	0.9	71min.	90min.	139min.	148min.	177min.	<a href="#">MHQ1005P0N9CT000</a>	
1.0	1.0	1.0	1.0	1.0	71min.	90min.	139min.	148min.	177min.	<a href="#">MHQ1005P1N0BT000</a>	
1.0	1.0	1.0	1.0	1.0	71min.	90min.	139min.	148min.	177min.	<a href="#">MHQ1005P1N0CT000</a>	
1.0	1.0	1.0	1.0	1.0	71min.	90min.	139min.	148min.	177min.	<a href="#">MHQ1005P1N0ST000</a>	
1.1	1.1	1.1	1.1	1.1	71min.	90min.	139min.	148min.	177min.	<a href="#">MHQ1005P1N1BT000</a>	
1.1	1.1	1.1	1.1	1.1	71min.	90min.	139min.	148min.	177min.	<a href="#">MHQ1005P1N1CT000</a>	
1.1	1.1	1.1	1.1	1.1	71min.	90min.	139min.	148min.	177min.	<a href="#">MHQ1005P1N1ST000</a>	
1.2	1.2	1.2	1.2	1.2	71min.	90min.	139min.	148min.	177min.	<a href="#">MHQ1005P1N2BT000</a>	
1.2	1.2	1.2	1.2	1.2	71min.	90min.	139min.	148min.	177min.	<a href="#">MHQ1005P1N2CT000</a>	
1.2	1.2	1.2	1.2	1.2	71min.	90min.	139min.	148min.	177min.	<a href="#">MHQ1005P1N2ST000</a>	
1.3	1.3	1.3	1.3	1.3	71	90	139	148	178	<a href="#">MHQ1005P1N3BT000</a>	
1.3	1.3	1.3	1.3	1.3	71	90	139	148	178	<a href="#">MHQ1005P1N3CT000</a>	
1.3	1.3	1.3	1.3	1.3	71	90	139	148	178	<a href="#">MHQ1005P1N3ST000</a>	
1.4	1.4	1.4	1.4	1.4	88	103	173	178	203	<a href="#">MHQ1005P1N4BT000</a>	
1.4	1.4	1.4	1.4	1.4	88	103	173	178	203	<a href="#">MHQ1005P1N4CT000</a>	
1.4	1.4	1.4	1.4	1.4	88	103	173	178	203	<a href="#">MHQ1005P1N4ST000</a>	
1.5	1.5	1.5	1.5	1.5	66	76	124	133	151	<a href="#">MHQ1005P1N5BT000</a>	
1.5	1.5	1.5	1.5	1.5	66	76	124	133	151	<a href="#">MHQ1005P1N5CT000</a>	
1.5	1.5	1.5	1.5	1.5	66	76	124	133	151	<a href="#">MHQ1005P1N5ST000</a>	
1.6	1.6	1.6	1.6	1.6	70	88	147	151	171	<a href="#">MHQ1005P1N6BT000</a>	
1.6	1.6	1.6	1.6	1.6	70	88	147	151	171	<a href="#">MHQ1005P1N6CT000</a>	
1.6	1.6	1.6	1.6	1.6	70	88	147	151	171	<a href="#">MHQ1005P1N6ST000</a>	
1.7	1.7	1.7	1.7	1.7	63	80	140	151	179	<a href="#">MHQ1005P1N7BT000</a>	
1.7	1.7	1.7	1.7	1.7	63	80	140	151	179	<a href="#">MHQ1005P1N7CT000</a>	
1.7	1.7	1.7	1.7	1.7	63	80	140	151	179	<a href="#">MHQ1005P1N7ST000</a>	
1.8	1.8	1.8	1.8	1.8	60	75	125	130	150	<a href="#">MHQ1005P1N8BT000</a>	
1.8	1.8	1.8	1.8	1.8	60	75	125	130	150	<a href="#">MHQ1005P1N8CT000</a>	
1.8	1.8	1.8	1.8	1.8	60	75	125	130	150	<a href="#">MHQ1005P1N8ST000</a>	
1.9	1.9	1.9	1.9	1.9	53	68	119	126	150	<a href="#">MHQ1005P1N9BT000</a>	
1.9	1.9	1.9	1.9	1.9	53	68	119	126	150	<a href="#">MHQ1005P1N9CT000</a>	
1.9	1.9	1.9	1.9	1.9	53	68	119	126	150	<a href="#">MHQ1005P1N9ST000</a>	
2.0	2.0	2.0	2.0	2.0	60	74	122	129	146	<a href="#">MHQ1005P2N0BT000</a>	
2.0	2.0	2.0	2.0	2.0	60	74	122	129	146	<a href="#">MHQ1005P2N0CT000</a>	
2.0	2.0	2.0	2.0	2.0	60	74	122	129	146	<a href="#">MHQ1005P2N0ST000</a>	
2.1	2.1	2.1	2.1	2.1	54	70	121	129	152	<a href="#">MHQ1005P2N1BT000</a>	
2.1	2.1	2.1	2.1	2.1	54	70	121	129	152	<a href="#">MHQ1005P2N1CT000</a>	
2.1	2.1	2.1	2.1	2.1	54	70	121	129	152	<a href="#">MHQ1005P2N1ST000</a>	
2.2	2.2	2.2	2.2	2.2	54	68	108	116	131	<a href="#">MHQ1005P2N2BT000</a>	
2.2	2.2	2.2	2.2	2.2	54	68	108	116	131	<a href="#">MHQ1005P2N2CT000</a>	
2.2	2.2	2.2	2.2	2.2	54	68	108	116	131	<a href="#">MHQ1005P2N2ST000</a>	

## Measurement equipment

Product No.	Manufacturer
4291B+16193A	Keysight Technologies

\* Equivalent measurement equipment may be used.

# MHQ1005P type

## L, Q FREQUENCY CHARACTERISTICS TABLE

L(nH)typ.					Q typ.					Part No.
500MHz	800MHz	1.8GHz	2.0GHz	2.4GHz	500MHz	800MHz	1.8GHz	2.0GHz	2.4GHz	
2.3	2.3	2.3	2.3	2.3	50	64	101	106	119	<a href="#">MHQ1005P2N3BT000</a>
2.3	2.3	2.3	2.3	2.3	50	64	101	106	119	<a href="#">MHQ1005P2N3CT000</a>
2.3	2.3	2.3	2.3	2.3	50	64	101	106	119	<a href="#">MHQ1005P2N3ST000</a>
2.4	2.3	2.4	2.4	2.4	50	64	105	110	125	<a href="#">MHQ1005P2N4BT000</a>
2.4	2.3	2.4	2.4	2.4	50	64	105	110	125	<a href="#">MHQ1005P2N4CT000</a>
2.4	2.3	2.4	2.4	2.4	50	64	105	110	125	<a href="#">MHQ1005P2N4ST000</a>
2.5	2.5	2.5	2.5	2.6	50	65	110	114	135	<a href="#">MHQ1005P2N5BT000</a>
2.5	2.5	2.5	2.5	2.6	50	65	110	114	135	<a href="#">MHQ1005P2N5CT000</a>
2.5	2.5	2.5	2.5	2.6	50	65	110	114	135	<a href="#">MHQ1005P2N5ST000</a>
2.5	2.5	2.6	2.6	2.7	48	65	103	107	122	<a href="#">MHQ1005P2N6BT000</a>
2.5	2.5	2.6	2.6	2.7	48	65	103	107	122	<a href="#">MHQ1005P2N6CT000</a>
2.5	2.5	2.6	2.6	2.7	48	65	103	107	122	<a href="#">MHQ1005P2N6ST000</a>
2.6	2.6	2.7	2.7	2.8	49	61	98	102	116	<a href="#">MHQ1005P2N7BT000</a>
2.6	2.6	2.7	2.7	2.8	49	61	98	102	116	<a href="#">MHQ1005P2N7CT000</a>
2.6	2.6	2.7	2.7	2.8	49	61	98	102	116	<a href="#">MHQ1005P2N7ST000</a>
2.7	2.7	2.8	2.8	2.9	46	58	100	105	123	<a href="#">MHQ1005P2N8BT000</a>
2.7	2.7	2.8	2.8	2.9	46	58	100	105	123	<a href="#">MHQ1005P2N8CT000</a>
2.7	2.7	2.8	2.8	2.9	46	58	100	105	123	<a href="#">MHQ1005P2N8ST000</a>
2.8	2.8	2.9	2.9	3.0	45	58	99	103	120	<a href="#">MHQ1005P2N9BT000</a>
2.8	2.8	2.9	2.9	3.0	45	58	99	103	120	<a href="#">MHQ1005P2N9CT000</a>
2.8	2.8	2.9	2.9	3.0	45	58	99	103	120	<a href="#">MHQ1005P2N9ST000</a>
2.9	2.9	3.0	3.0	3.1	49	62	102	106	120	<a href="#">MHQ1005P3N0BT000</a>
2.9	2.9	3.0	3.0	3.1	49	62	102	106	120	<a href="#">MHQ1005P3N0CT000</a>
2.9	2.9	3.0	3.0	3.1	49	62	102	106	120	<a href="#">MHQ1005P3N0ST000</a>
3.0	3.0	3.1	3.1	3.2	45	58	99	104	121	<a href="#">MHQ1005P3N1BT000</a>
3.0	3.0	3.1	3.1	3.2	45	58	99	104	121	<a href="#">MHQ1005P3N1CT000</a>
3.0	3.0	3.1	3.1	3.2	45	58	99	104	121	<a href="#">MHQ1005P3N1ST000</a>
3.1	3.1	3.2	3.2	3.3	45	58	99	106	121	<a href="#">MHQ1005P3N2BT000</a>
3.1	3.1	3.2	3.2	3.3	45	58	99	106	121	<a href="#">MHQ1005P3N2CT000</a>
3.1	3.1	3.2	3.2	3.3	45	58	99	106	121	<a href="#">MHQ1005P3N2ST000</a>
3.2	3.2	3.3	3.4	3.4	48	60	96	101	115	<a href="#">MHQ1005P3N3BT000</a>
3.2	3.2	3.3	3.4	3.4	48	60	96	101	115	<a href="#">MHQ1005P3N3CT000</a>
3.2	3.2	3.3	3.4	3.4	48	60	96	101	115	<a href="#">MHQ1005P3N3ST000</a>
3.3	3.3	3.4	3.5	3.5	45	57	96	102	118	<a href="#">MHQ1005P3N4BT000</a>
3.3	3.3	3.4	3.5	3.5	45	57	96	102	118	<a href="#">MHQ1005P3N4CT000</a>
3.3	3.3	3.4	3.5	3.5	45	57	96	102	118	<a href="#">MHQ1005P3N4ST000</a>
3.4	3.4	3.5	3.6	3.6	43	57	89	92	104	<a href="#">MHQ1005P3N5BT000</a>
3.4	3.4	3.5	3.6	3.6	43	57	89	92	104	<a href="#">MHQ1005P3N5CT000</a>
3.4	3.4	3.5	3.6	3.6	43	57	89	92	104	<a href="#">MHQ1005P3N5ST000</a>
3.5	3.5	3.6	3.6	3.7	43	56	91	96	110	<a href="#">MHQ1005P3N6BT000</a>
3.5	3.5	3.6	3.6	3.7	43	56	91	96	110	<a href="#">MHQ1005P3N6CT000</a>
3.5	3.5	3.6	3.6	3.7	43	56	91	96	110	<a href="#">MHQ1005P3N6ST000</a>
3.6	3.6	3.7	3.8	3.9	46	57	96	100	114	<a href="#">MHQ1005P3N7BT000</a>
3.6	3.6	3.7	3.8	3.9	46	57	96	100	114	<a href="#">MHQ1005P3N7CT000</a>
3.6	3.6	3.7	3.8	3.9	46	57	96	100	114	<a href="#">MHQ1005P3N7ST000</a>
3.7	3.7	3.9	3.9	4.0	45	59	93	96	109	<a href="#">MHQ1005P3N8BT000</a>
3.7	3.7	3.9	3.9	4.0	45	59	93	96	109	<a href="#">MHQ1005P3N8CT000</a>
3.7	3.7	3.9	3.9	4.0	45	59	93	96	109	<a href="#">MHQ1005P3N8ST000</a>

### Measurement equipment

Product No.	Manufacturer
4291B+16193A	Keysight Technologies

\* Equivalent measurement equipment may be used.

## MHQ1005P type

## L, Q FREQUENCY CHARACTERISTICS TABLE

L(nH)typ.					Q typ.					Part No.
500MHz	800MHz	1.8GHz	2.0GHz	2.4GHz	500MHz	800MHz	1.8GHz	2.0GHz	2.4GHz	
3.8	3.8	4.0	4.0	4.1	48	61	96	99	111	<a href="#">MHQ1005P3N9BT000</a>
3.8	3.8	4.0	4.0	4.1	48	61	96	99	111	<a href="#">MHQ1005P3N9CT000</a>
3.8	3.8	4.0	4.0	4.1	48	61	96	99	111	<a href="#">MHQ1005P3N9ST000</a>
4.0	4.0	4.2	4.3	4.4	46	59	98	101	115	<a href="#">MHQ1005P4N1BT000</a>
4.0	4.0	4.2	4.3	4.4	46	59	98	101	115	<a href="#">MHQ1005P4N1CT000</a>
4.0	4.0	4.2	4.3	4.4	46	59	98	101	115	<a href="#">MHQ1005P4N1ST000</a>
4.2	4.2	4.4	4.5	4.6	47	60	95	97	107	<a href="#">MHQ1005P4N3BT000</a>
4.2	4.2	4.4	4.5	4.6	47	60	95	97	107	<a href="#">MHQ1005P4N3CT000</a>
4.2	4.2	4.4	4.5	4.6	47	60	95	97	107	<a href="#">MHQ1005P4N3ST000</a>
4.6	4.6	4.8	4.9	5.0	44	56	89	93	102	<a href="#">MHQ1005P4N7BT000</a>
4.6	4.6	4.8	4.9	5.0	44	56	89	93	102	<a href="#">MHQ1005P4N7CT000</a>
4.6	4.6	4.8	4.9	5.0	44	56	89	93	102	<a href="#">MHQ1005P4N7ST000</a>
5.0	5.0	5.2	5.3	5.5	43	55	86	90	99	<a href="#">MHQ1005P5N1BT000</a>
5.0	5.0	5.2	5.3	5.5	43	55	86	90	99	<a href="#">MHQ1005P5N1CT000</a>
5.0	5.0	5.2	5.3	5.5	43	55	86	90	99	<a href="#">MHQ1005P5N1ST000</a>
5.5	5.5	5.8	5.9	6.1	43	54	84	87	94	<a href="#">MHQ1005P5N6BT000</a>
5.5	5.5	5.8	5.9	6.1	43	54	84	87	94	<a href="#">MHQ1005P5N6CT000</a>
5.5	5.5	5.8	5.9	6.1	43	54	84	87	94	<a href="#">MHQ1005P5N6ST000</a>
5.7	5.7	6.1	6.2	6.5	43	57	84	87	94	<a href="#">MHQ1005P5N8BT000</a>
5.7	5.7	6.1	6.2	6.5	43	57	84	87	94	<a href="#">MHQ1005P5N8CT000</a>
5.7	5.7	6.1	6.2	6.5	43	57	84	87	94	<a href="#">MHQ1005P5N8ST000</a>
6.1	6.1	6.6	6.7	7.0	45	57	85	87	93	<a href="#">MHQ1005P6N2BT000</a>
6.1	6.1	6.6	6.7	7.0	45	57	85	87	93	<a href="#">MHQ1005P6N2CT000</a>
6.1	6.1	6.6	6.7	7.0	45	57	85	87	93	<a href="#">MHQ1005P6N2ST000</a>
6.7	6.7	7.3	7.5	7.9	45	58	85	88	92	<a href="#">MHQ1005P6N8GT000</a>
6.7	6.7	7.3	7.5	7.9	45	58	85	88	92	<a href="#">MHQ1005P6N8HT000</a>
6.7	6.7	7.3	7.5	7.9	45	58	85	88	92	<a href="#">MHQ1005P6N8JT000</a>
7.1	7.2	7.7	7.9	8.3	40	52	77	80	84	<a href="#">MHQ1005P7N3GT000</a>
7.1	7.2	7.7	7.9	8.3	40	52	77	80	84	<a href="#">MHQ1005P7N3HT000</a>
7.1	7.2	7.7	7.9	8.3	40	52	77	80	84	<a href="#">MHQ1005P7N3JT000</a>
7.3	7.4	7.9	8.1	8.5	42	54	80	83	88	<a href="#">MHQ1005P7N5GT000</a>
7.3	7.4	7.9	8.1	8.5	42	54	80	83	88	<a href="#">MHQ1005P7N5HT000</a>
7.3	7.4	7.9	8.1	8.5	42	54	80	83	88	<a href="#">MHQ1005P7N5JT000</a>
8.0	8.1	9.0	9.4	10.0	44	56	80	81	82	<a href="#">MHQ1005P8N2GT000</a>
8.0	8.1	9.0	9.4	10.0	44	56	80	81	82	<a href="#">MHQ1005P8N2HT000</a>
8.0	8.1	9.0	9.4	10.0	44	56	80	81	82	<a href="#">MHQ1005P8N2JT000</a>
8.5	8.6	9.6	10.0	10.8	42	52	78	79	80	<a href="#">MHQ1005P8N7GT000</a>
8.5	8.6	9.6	10.0	10.8	42	52	78	79	80	<a href="#">MHQ1005P8N7HT000</a>
8.5	8.6	9.6	10.0	10.8	42	52	78	79	80	<a href="#">MHQ1005P8N7JT000</a>
8.9	9.1	10.1	10.5	11.3	43	54	77	78	79	<a href="#">MHQ1005P9N1GT000</a>
8.9	9.1	10.1	10.5	11.3	43	54	77	78	79	<a href="#">MHQ1005P9N1HT000</a>
8.9	9.1	10.1	10.5	11.3	43	54	77	78	79	<a href="#">MHQ1005P9N1JT000</a>

## Measurement equipment

Product No.	Manufacturer
4291B+16193A	Keysight Technologies

\* Equivalent measurement equipment may be used.

# MHQ1005P type

## L, Q FREQUENCY CHARACTERISTICS TABLE

L(nH)typ.					Q typ.					Part No.
500MHz	800MHz	1.8GHz	2.0GHz	2.4GHz	500MHz	800MHz	1.8GHz	2.0GHz	2.4GHz	
9.3	9.4	10.6	11.1	12.0	42	54	75	75	75	<a href="#">MHQ1005P9N5GT000</a>
9.3	9.4	10.6	11.1	12.0	42	54	75	75	75	<a href="#">MHQ1005P9N5HT000</a>
9.3	9.4	10.6	11.1	12.0	42	54	75	75	75	<a href="#">MHQ1005P9N5JT000</a>
10	10	11	12	13	42	54	73	74	74	<a href="#">MHQ1005P10NGT000</a>
10	10	11	12	13	42	54	73	74	74	<a href="#">MHQ1005P10NHT000</a>
10	10	11	12	13	42	54	73	74	74	<a href="#">MHQ1005P10NJT000</a>
11	11	13	13	14	41	52	70	70	69	<a href="#">MHQ1005P11NGT000</a>
11	11	13	13	14	41	52	70	70	69	<a href="#">MHQ1005P11NHT000</a>
11	11	13	13	14	41	52	70	70	69	<a href="#">MHQ1005P11NJT000</a>
12	12	14	15	17	40	50	66	65	61	<a href="#">MHQ1005P12NGT000</a>
12	12	14	15	17	40	50	66	65	61	<a href="#">MHQ1005P12NHT000</a>
12	12	14	15	17	40	50	66	65	61	<a href="#">MHQ1005P12NJT000</a>
13	13	16	17	19	42	53	66	66	61	<a href="#">MHQ1005P13NGT000</a>
13	13	16	17	19	42	53	66	66	61	<a href="#">MHQ1005P13NHT000</a>
13	13	16	17	19	42	53	66	66	61	<a href="#">MHQ1005P13NJT000</a>
15	15	19	21	26	39	48	57	54	46	<a href="#">MHQ1005P15NGT000</a>
15	15	19	21	26	39	48	57	54	46	<a href="#">MHQ1005P15NHT000</a>
15	15	19	21	26	39	48	57	54	46	<a href="#">MHQ1005P15NJT000</a>
16	16	20	21	25	34	43	54	52	49	<a href="#">MHQ1005P16NGT000</a>
16	16	20	21	25	34	43	54	52	49	<a href="#">MHQ1005P16NHT000</a>
16	16	20	21	25	34	43	54	52	49	<a href="#">MHQ1005P16NJT000</a>
18	18	23	25	30	39	49	60	57	51	<a href="#">MHQ1005P18NGT000</a>
18	18	23	25	30	39	49	60	57	51	<a href="#">MHQ1005P18NHT000</a>
18	18	23	25	30	39	49	60	57	51	<a href="#">MHQ1005P18NJT000</a>
19	19	25	28	35	39	49	59	55	46	<a href="#">MHQ1005P19NGT000</a>
19	19	25	28	35	39	49	59	55	46	<a href="#">MHQ1005P19NHT000</a>
19	19	25	28	35	39	49	59	55	46	<a href="#">MHQ1005P19NJT000</a>
20	20	26	29	35	38	47	56	53	43	<a href="#">MHQ1005P20NGT000</a>
20	20	26	29	35	38	47	56	53	43	<a href="#">MHQ1005P20NHT000</a>
20	20	26	29	35	38	47	56	53	43	<a href="#">MHQ1005P20NJT000</a>
22	23	31	35	—	34	42	47	43	—	<a href="#">MHQ1005P22NGT000</a>
22	23	31	35	—	34	42	47	43	—	<a href="#">MHQ1005P22NHT000</a>
22	23	31	35	—	34	42	47	43	—	<a href="#">MHQ1005P22NJT000</a>
23	24	33	37	—	41	50	53	48	—	<a href="#">MHQ1005P23NGT000</a>
23	24	33	37	—	41	50	53	48	—	<a href="#">MHQ1005P23NHT000</a>
23	24	33	37	—	41	50	53	48	—	<a href="#">MHQ1005P23NJT000</a>
24	25	35	41	—	39	49	50	44	—	<a href="#">MHQ1005P24NGT000</a>
24	25	35	41	—	39	49	50	44	—	<a href="#">MHQ1005P24NHT000</a>
24	25	35	41	—	39	49	50	44	—	<a href="#">MHQ1005P24NJT000</a>
27	28	42	50	—	37	45	44	37	—	<a href="#">MHQ1005P27NGT000</a>
27	28	42	50	—	37	45	44	37	—	<a href="#">MHQ1005P27NHT000</a>
27	28	42	50	—	37	45	44	37	—	<a href="#">MHQ1005P27NJT000</a>
30	32	55	—	—	33	40	34	—	—	<a href="#">MHQ1005P30NGT000</a>
30	32	55	—	—	33	40	34	—	—	<a href="#">MHQ1005P30NHT000</a>
30	32	55	—	—	33	40	34	—	—	<a href="#">MHQ1005P30NJT000</a>

### Measurement equipment

Product No.	Manufacturer
4291B+16193A	Keysight Technologies

\* Equivalent measurement equipment may be used.

# MHQ1005P type

## L, Q FREQUENCY CHARACTERISTICS TABLE

L(nH)typ.					Q typ.					Part No.
500MHz	800MHz	1.8GHz	2.0GHz	2.4GHz	500MHz	800MHz	1.8GHz	2.0GHz	2.4GHz	
33	35	59	—	—	37	44	37	—	—	MHQ1005P33NGT000
33	35	59	—	—	37	44	37	—	—	MHQ1005P33NHT000
33	35	59	—	—	37	44	37	—	—	MHQ1005P33NJT000
36	39	69	—	—	35	42	32	—	—	MHQ1005P36NGT000
36	39	69	—	—	35	42	32	—	—	MHQ1005P36NHT000
36	39	69	—	—	35	42	32	—	—	MHQ1005P36NJT000
40	43	—	—	—	33	38	—	—	—	MHQ1005P39NGT000
40	43	—	—	—	33	38	—	—	—	MHQ1005P39NHT000
40	43	—	—	—	33	38	—	—	—	MHQ1005P39NJT000
41	44	—	—	—	36	42	—	—	—	MHQ1005P40NGT000
41	44	—	—	—	36	42	—	—	—	MHQ1005P40NHT000
41	44	—	—	—	36	42	—	—	—	MHQ1005P40NJT000
44	47	—	—	—	36	42	—	—	—	MHQ1005P43NGT000
44	47	—	—	—	36	42	—	—	—	MHQ1005P43NHT000
44	47	—	—	—	36	42	—	—	—	MHQ1005P43NJT000
48	53	—	—	—	34	38	—	—	—	MHQ1005P47NGT000
48	53	—	—	—	34	38	—	—	—	MHQ1005P47NHT000
48	53	—	—	—	34	38	—	—	—	MHQ1005P47NJT000
52	58	—	—	—	35	40	—	—	—	MHQ1005P51NGT000
52	58	—	—	—	35	40	—	—	—	MHQ1005P51NHT000
52	58	—	—	—	35	40	—	—	—	MHQ1005P51NJT000
58	65	—	—	—	34	37	—	—	—	MHQ1005P56NGT000
58	65	—	—	—	34	37	—	—	—	MHQ1005P56NHT000
58	65	—	—	—	34	37	—	—	—	MHQ1005P56NJT000
65	74	—	—	—	34	37	—	—	—	MHQ1005P62NGT000
65	74	—	—	—	34	37	—	—	—	MHQ1005P62NHT000
65	74	—	—	—	34	37	—	—	—	MHQ1005P62NJT000
72	82	—	—	—	35	37	—	—	—	MHQ1005P68NGT000
72	82	—	—	—	35	37	—	—	—	MHQ1005P68NHT000
72	82	—	—	—	35	37	—	—	—	MHQ1005P68NJT000
77	90	—	—	—	34	36	—	—	—	MHQ1005P72NGT000
77	90	—	—	—	34	36	—	—	—	MHQ1005P72NHT000
77	90	—	—	—	34	36	—	—	—	MHQ1005P72NJT000
80	93	—	—	—	35	37	—	—	—	MHQ1005P75NGT000
80	93	—	—	—	35	37	—	—	—	MHQ1005P75NHT000
80	93	—	—	—	35	37	—	—	—	MHQ1005P75NJT000
88	107	—	—	—	35	35	—	—	—	MHQ1005P82NGT000
88	107	—	—	—	35	35	—	—	—	MHQ1005P82NHT000
88	107	—	—	—	35	35	—	—	—	MHQ1005P82NJT000
98	121	—	—	—	33	32	—	—	—	MHQ1005P91NGT000
98	121	—	—	—	33	32	—	—	—	MHQ1005P91NHT000
98	121	—	—	—	33	32	—	—	—	MHQ1005P91NJT000
111	143	—	—	—	33	33	—	—	—	MHQ1005PR10GT000
111	143	—	—	—	33	33	—	—	—	MHQ1005PR10HT000
111	143	—	—	—	33	33	—	—	—	MHQ1005PR10JT000

### Measurement equipment

Product No.	Manufacturer
4291B+16193A	Keysight Technologies

\* Equivalent measurement equipment may be used.

# MHQ1005P type

## L, Q FREQUENCY CHARACTERISTICS TABLE

L(nH)typ.					Q typ.					Part No.
500MHz	800MHz	1.8GHz	2.0GHz	2.4GHz	500MHz	800MHz	1.8GHz	2.0GHz	2.4GHz	
124	169	—	—	—	31	28	—	—	—	MHQ1005PR11GT000
124	169	—	—	—	31	28	—	—	—	MHQ1005PR11HT000
124	169	—	—	—	31	28	—	—	—	MHQ1005PR11JT000
138	197	—	—	—	30	26	—	—	—	MHQ1005PR12GT000
138	197	—	—	—	30	26	—	—	—	MHQ1005PR12HT000
138	197	—	—	—	30	26	—	—	—	MHQ1005PR12JT000
150	220	—	—	—	31	23	—	—	—	MHQ1005PR13GT000
150	220	—	—	—	31	23	—	—	—	MHQ1005PR13HT000
150	220	—	—	—	31	23	—	—	—	MHQ1005PR13JT000
177	276	—	—	—	30	22	—	—	—	MHQ1005PR15GT000
177	276	—	—	—	30	22	—	—	—	MHQ1005PR15HT000
177	276	—	—	—	30	22	—	—	—	MHQ1005PR15JT000
194	—	—	—	—	28	—	—	—	—	MHQ1005PR16GT000
194	—	—	—	—	28	—	—	—	—	MHQ1005PR16HT000
194	—	—	—	—	28	—	—	—	—	MHQ1005PR16JT000
223	—	—	—	—	28	—	—	—	—	MHQ1005PR18GT000
223	—	—	—	—	28	—	—	—	—	MHQ1005PR18HT000
223	—	—	—	—	28	—	—	—	—	MHQ1005PR18JT000
254	—	—	—	—	27	—	—	—	—	MHQ1005PR20GT000
254	—	—	—	—	27	—	—	—	—	MHQ1005PR20HT000
254	—	—	—	—	27	—	—	—	—	MHQ1005PR20JT000
285	—	—	—	—	27	—	—	—	—	MHQ1005PR22GT000
285	—	—	—	—	27	—	—	—	—	MHQ1005PR22HT000
285	—	—	—	—	27	—	—	—	—	MHQ1005PR22JT000
317	—	—	—	—	26	—	—	—	—	MHQ1005PR24GT000
317	—	—	—	—	26	—	—	—	—	MHQ1005PR24HT000
317	—	—	—	—	26	—	—	—	—	MHQ1005PR24JT000
375	—	—	—	—	25	—	—	—	—	MHQ1005PR27GT000
375	—	—	—	—	25	—	—	—	—	MHQ1005PR27HT000
375	—	—	—	—	25	—	—	—	—	MHQ1005PR27JT000
448	—	—	—	—	23	—	—	—	—	MHQ1005PR30GT000
448	—	—	—	—	23	—	—	—	—	MHQ1005PR30HT000
448	—	—	—	—	23	—	—	—	—	MHQ1005PR30JT000
518	—	—	—	—	22	—	—	—	—	MHQ1005PR33GT000
518	—	—	—	—	22	—	—	—	—	MHQ1005PR33HT000
518	—	—	—	—	22	—	—	—	—	MHQ1005PR33JT000
599	—	—	—	—	21	—	—	—	—	MHQ1005PR36GT000
599	—	—	—	—	21	—	—	—	—	MHQ1005PR36HT000
599	—	—	—	—	21	—	—	—	—	MHQ1005PR36JT000
693	—	—	—	—	19	—	—	—	—	MHQ1005PR39GT000
693	—	—	—	—	19	—	—	—	—	MHQ1005PR39HT000
693	—	—	—	—	19	—	—	—	—	MHQ1005PR39JT000
—	—	—	—	—	—	—	—	—	—	MHQ1005PR43GT000
—	—	—	—	—	—	—	—	—	—	MHQ1005PR43HT000
—	—	—	—	—	—	—	—	—	—	MHQ1005PR43JT000
—	—	—	—	—	—	—	—	—	—	MHQ1005PR47GT000
—	—	—	—	—	—	—	—	—	—	MHQ1005PR47HT000
—	—	—	—	—	—	—	—	—	—	MHQ1005PR47JT000
—	—	—	—	—	—	—	—	—	—	MHQ1005PR51GT000
—	—	—	—	—	—	—	—	—	—	MHQ1005PR51HT000
—	—	—	—	—	—	—	—	—	—	MHQ1005PR51JT000
—	—	—	—	—	—	—	—	—	—	MHQ1005PR56GT000
—	—	—	—	—	—	—	—	—	—	MHQ1005PR56HT000
—	—	—	—	—	—	—	—	—	—	MHQ1005PR56JT000

Measurement equipment

Product No.	Manufacturer
4291B+16193A	Keysight Technologies

\* Equivalent measurement equipment may be used.

# MHQ1005P type

## ■ L FREQUENCY CHARACTERISTICS (EXAMPLE)

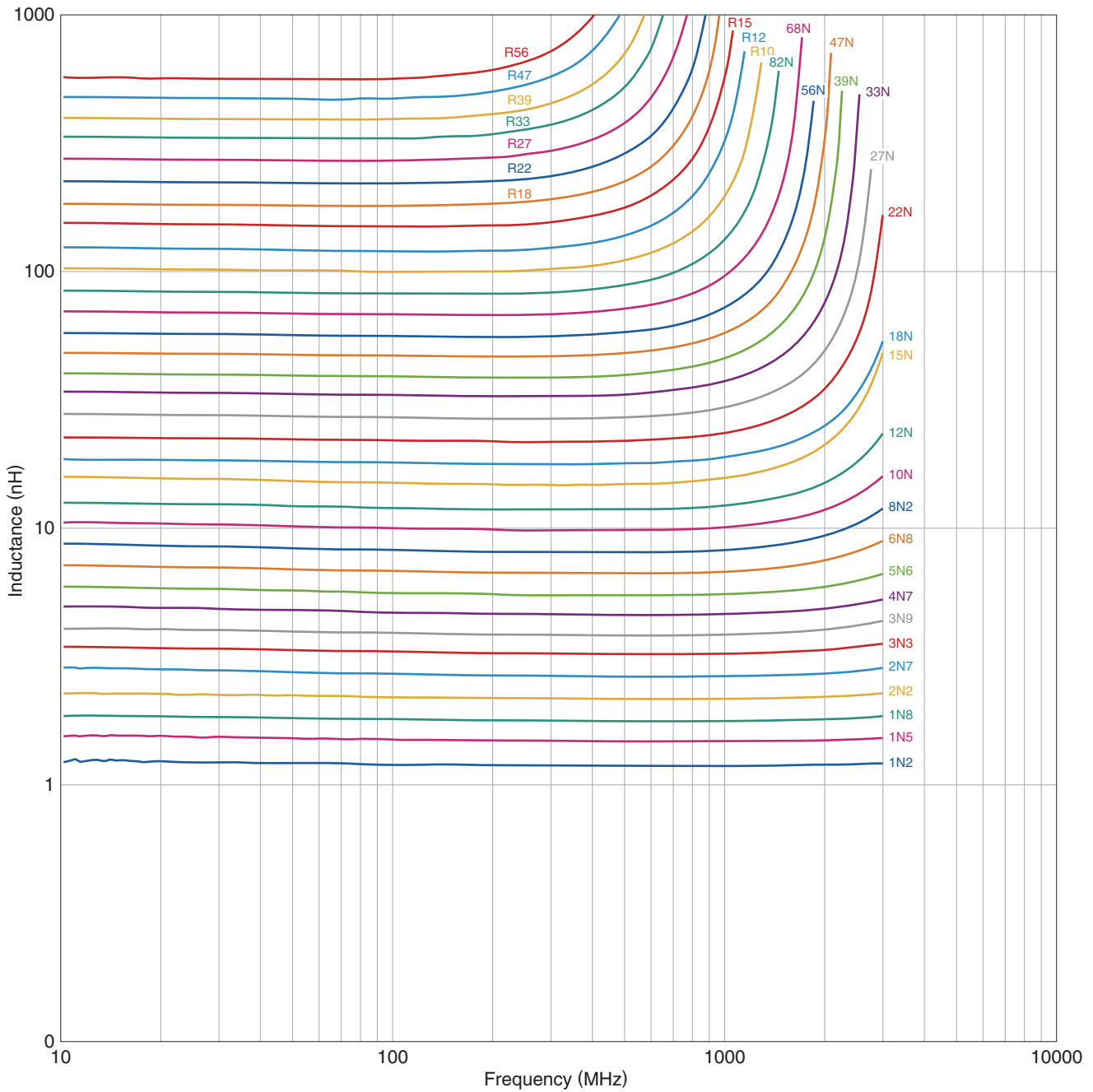

Measurement equipment

Product No.	Manufacturer
E4991+16193A	Keysight Technologies

\* Equivalent measurement equipment may be used.

# MHQ1005P type

## Q FREQUENCY CHARACTERISTICS (EXAMPLE)

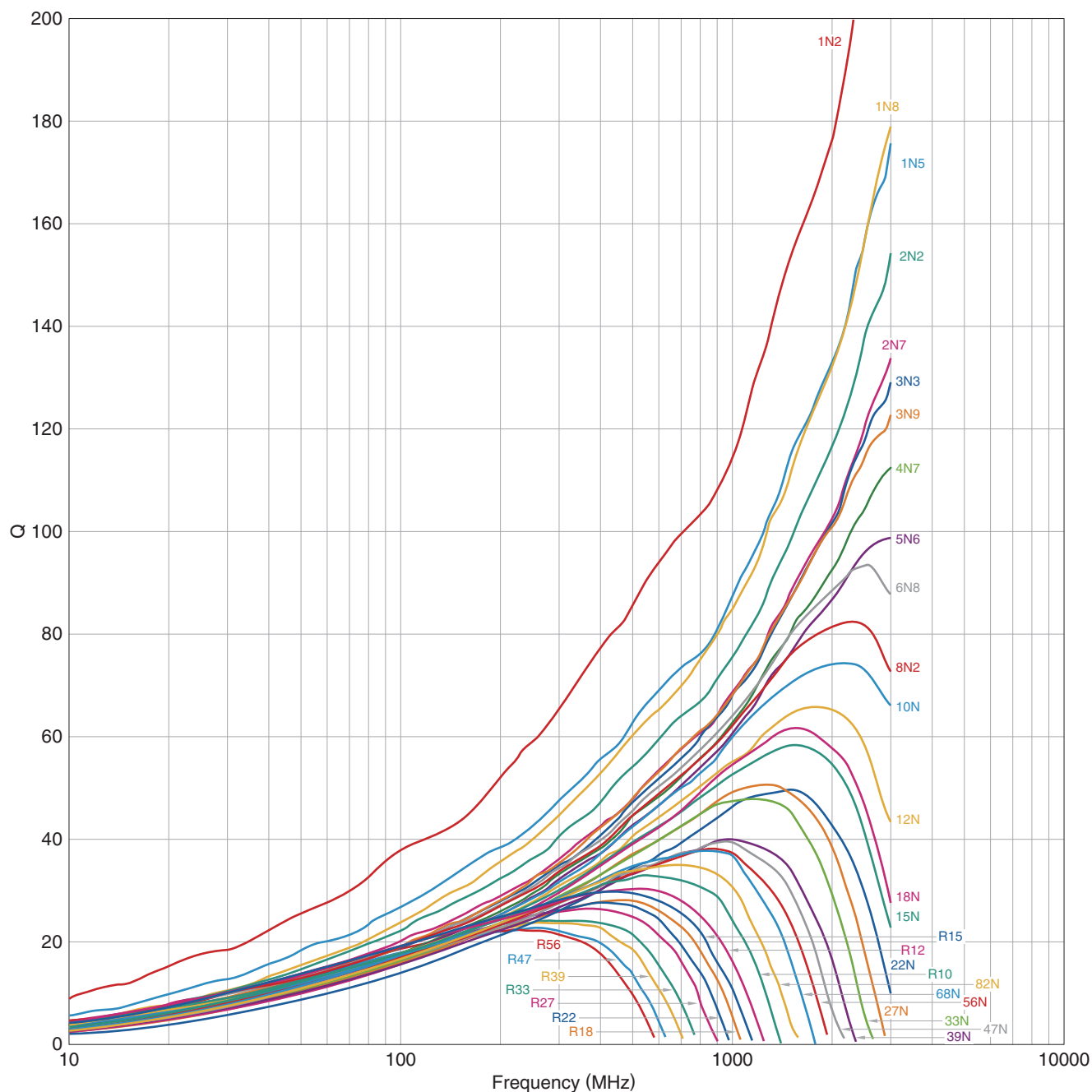

Measurement equipment

Product No.	Manufacturer
E4991+16193A	Keysight Technologies

\* Equivalent measurement equipment may be used.

# MHQ1005P type

## SHAPE & DIMENSIONS

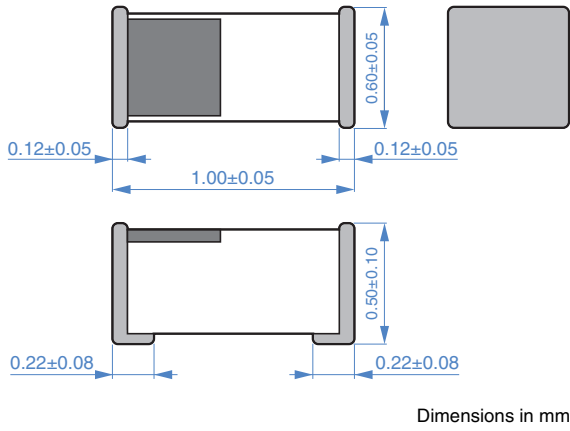

## PACKAGING STYLE

### REEL DIMENSIONS

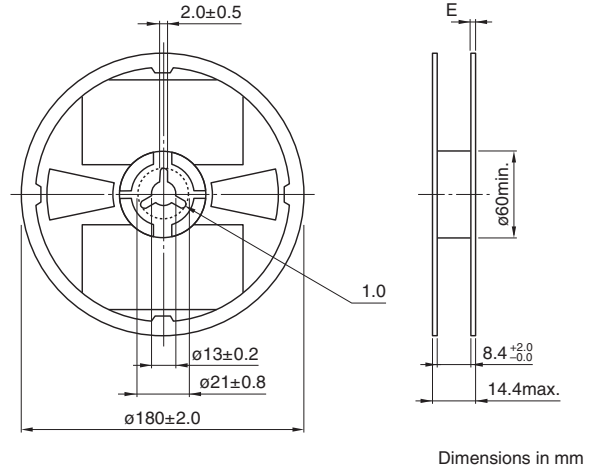

## RECOMMENDED LAND PATTERN

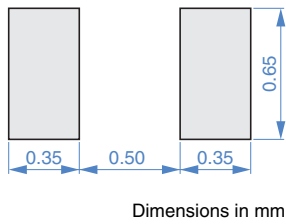

### TAPE DIMENSIONS

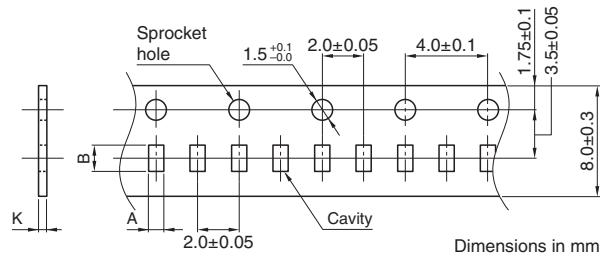

## RECOMMENDED REFLOW PROFILE

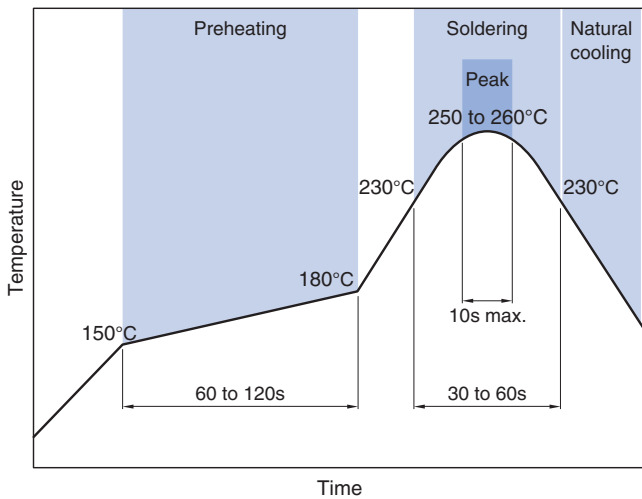

Type	A	B	K
MHQ1005P	$0.75 \pm 0.10$	$1.15 \pm 0.10$	$0.8 \text{ max.}$

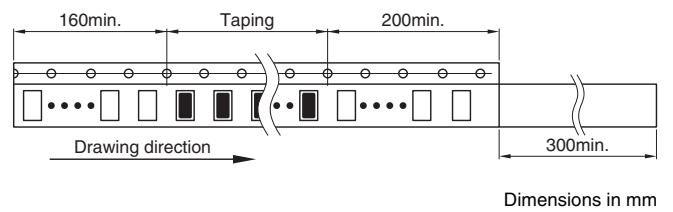

### PACKAGE QUANTITY

Package quantity	10000 pcs/reel
------------------	----------------

## TEMPERATURE RANGE, INDIVIDUAL WEIGHT

Operating temperature range	Storage temperature range*	Individual weight
$-55$ to $+125^\circ\text{C}$	$-55$ to $+125^\circ\text{C}$	1 mg

\* The storage temperature range is for after the assembly.

## REMINDERS FOR USING THESE PRODUCTS

Before using these products, be sure to request the delivery specifications.

### SAFETY REMINDERS

Please pay sufficient attention to the warnings for safe designing when using this products.

#### REMINDERS

- The storage period is less than 12 months. Be sure to follow the storage conditions (temperature: 5 to 40°C, humidity: 10 to 75% RH or less).  
If the storage period elapses, the soldering of the terminal electrodes may deteriorate.
- Do not use or store in locations where there are conditions such as gas corrosion (salt, acid, alkali, etc.).
- Before soldering, be sure to preheat components.  
The preheating temperature should be set so that the temperature difference between the solder temperature and chip temperature does not exceed 150°C.
- Soldering corrections after mounting should be within the range of the conditions determined in the specifications.  
If overheated, a short circuit, performance deterioration, or lifespan shortening may occur.
- When embedding a printed circuit board where a chip is mounted to a set, be sure that residual stress is not given to the chip due to the overall distortion of the printed circuit board and partial distortion such as at screw tightening portions.
- Self heating (temperature increase) occurs when the power is turned ON, so the tolerance should be sufficient for the set thermal design.
- Carefully lay out the coil for the circuit board design of the non-magnetic shield type.  
A malfunction may occur due to magnetic interference.
- Use a wrist band to discharge static electricity in your body through the grounding wire.
- Do not expose the products to magnets or magnetic fields.
- Do not use for a purpose outside of the contents regulated in the delivery specifications.
- The products listed on this catalog are intended for use in general electronic equipment (AV equipment, telecommunications equipment, home appliances, amusement equipment, computer equipment, personal equipment, office equipment, measurement equipment, industrial robots) under a normal operation and use condition.  
The products are not designed or warranted to meet the requirements of the applications listed below, whose performance and/or quality require a more stringent level of safety or reliability, or whose failure, malfunction or trouble could cause serious damage to society, person or property.  
If you intend to use the products in the applications listed below or if you have special requirements exceeding the range or conditions set forth in the each catalog, please contact us.



- (1) Aerospace/aviation equipment
- (2) Transportation equipment (cars, electric trains, ships, etc.)
- (3) Medical equipment
- (4) Power-generation control equipment
- (5) Atomic energy-related equipment
- (6) Seabed equipment
- (7) Transportation control equipment

- (8) Public information-processing equipment
- (9) Military equipment
- (10) Electric heating apparatus, burning equipment
- (11) Disaster prevention/crime prevention equipment
- (12) Safety equipment
- (13) Other applications that are not considered general-purpose applications

When designing your equipment even for general-purpose applications, you are kindly requested to take into consideration securing protection circuit/device or providing backup circuits in your equipment.

## Looking for pricing, stock, or lifecycle information?

Click below to explore more details on WIN SOURCE:

-  [View MHQ1005P3N0CT000 on WIN SOURCE](#)
-  [TDK Corporation Information](#)

## Optimize Your Supply Chain with WIN SOURCE Solutions

-  Global Sourcing Solution
-  Obsolete Management
-  Cost Control Management
-  Shortage Management
-  Alternative Solution
-  Excess Inventory Management