



**THE DATASHEET OF  
MIC384-3BMM**



### General Description

The MIC384 is a versatile digital thermal supervisor capable of measuring temperature using its own internal sensor and two inexpensive external sensors or embedded silicon diodes such as those found in the Intel Pentium III\* CPU. A 2-wire serial interface is provided to allow communication with either I<sup>2</sup>C\*\* or SMBus\* masters. The open-drain interrupt output pin can be used as either an over-temperature alarm or a thermostatic control signal.

Interrupt mask and status bits are provided for reduced software overhead. Fault queues prevent nuisance tripping due to thermal or electrical noise. A programmable address pin permits two devices to share the bus. (Alternate base addresses available – contact Micrel.) Superior performance, low power and small size makes the MIC384 an excellent choice for multiple zone thermal management applications.

\*SMBus and Pentium III are trademarks of Intel Corporation.

\*\*I<sup>2</sup>C is a trademark of Philips Electronics, N.V.

### Ordering Information

Part Number		Base Address (*)	Junction Temp. Range	Package	Availability
Standard	Pb-Free				
MIC384-0BM	MIC384-0YM	100 100x	-55°C to +125°C	8-Lead SOIC	
MIC384-1BM	MIC384-1YM	100 101x	-55°C to +125°C	8-Lead SOIC	Contact Factory
MIC384-2BM	MIC384-2YM	100 110x	-55°C to +125°C	8-Lead SOIC	Contact Factory
MIC384-3BM	MIC384-3YM	100 111x	-55°C to +125°C	8-Lead SOIC	Contact Factory
MIC384-0BMM	MIC384-0YMM	100 100x	-55°C to +125°C	8-Lead MSOP	
MIC384-1BMM	MIC384-1YMM	100 101x	-55°C to +125°C	8-Lead MSOP	Contact Factory
MIC384-2BMM	MIC384-2YMM	100 110x	-55°C to +125°C	8-Lead MSOP	Contact Factory
MIC384-3BMM	MIC384-3YMM	100 111x	-55°C to +125°C	8-Lead MSOP	Contact Factory

\* The least-significant bit of the slave address is determined by the state of the A0 pin.

### Features

- Measures Local and Two Remote Temperatures
- 2-Wire SMBus-compatible Interface
- Programmable Thermostat Settings for All Three Zones
- Open-Drain Interrupt Output Pin
- Interrupt Mask and Status Bits
- Fault Queues to Prevent Nuisance Tripping
- Low Power Shutdown Mode
- Failsafe response to diode faults
- 2.7V to 5.5V Power Supply Range
- 8-Lead SOIC and MSOP Packages

### Applications

- Desktop, Server and Notebook Computers
- Power Supplies
- Test and Measurement Equipment
- Wireless Systems
- Networking/Datacom Hardware

### Typical Application

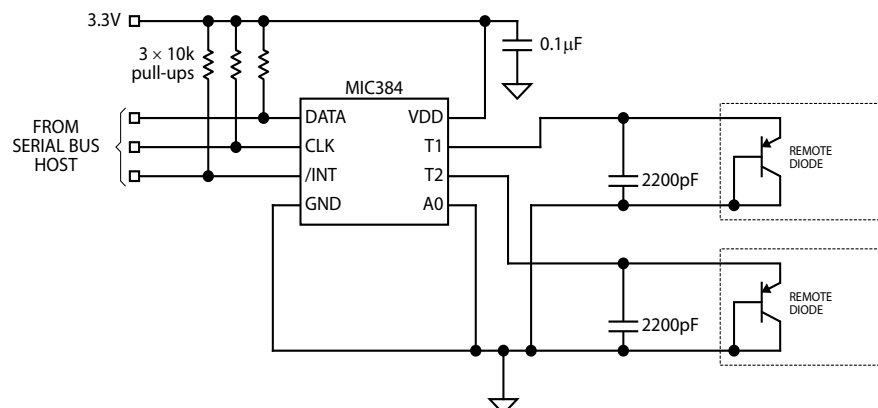

**3-Channel SMBus Temperature Measurement System**

## Pin Configuration

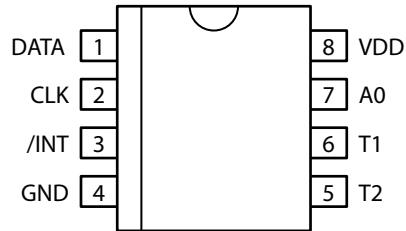

## Pin Description

Pin Number	Pin Name	Pin Function
1	DATA	Digital I/O: Open-drain. Serial data input/output.
2	CLK	Digital Input: The host provides the serial bit clock on this input.
3	/INT	Digital Output: Open-drain. Interrupt or thermostat output.
4	GND	Ground: Power and signal return for all IC functions.
5	T2	Analog Input: Connection to remote temperature sensor (diode junction)
6	T1	Analog Input: Connection to remote temperature sensor (diode junction)
7	A0	Digital Input: Slave address selection input. See Table 1. MIC384 Slave Address Settings.
8	VDD	Analog Input: Power supply input to the IC.

**Absolute Maximum Ratings (Note 1)**

Power Supply Voltage, $V_{DD}$ .....	6.0V
Voltage on Any Pin .....	-0.3V to $V_{DD}+0.3V$
Current Into Any Pin .....	$\pm 10mA$
Power Dissipation, $T_A = +125^\circ C$ .....	30mW
Junction Temperature .....	+150°C
Storage Temperature .....	-65°C to +150°C
<b>ESD Ratings (Note 3)</b>	
Human Body Model.....	TBD V
Machine Model .....	TBD V
<b>Soldering</b>	
Vapor Phase (60 sec.) .....	+220°C $\pm 5$ -0°C
Infrared (15 sec.) .....	+235°C $\pm 5$ -0°C

**Operating Ratings (Note 2)**

Power Supply Voltage, $V_{DD}$ .....	+2.7V to +5.5V
Ambient Temperature Range ( $T_A$ ) .....	-55°C to +125°C
<b>Package Thermal Resistance (<math>\theta_{JA}</math>)</b>	
SOP .....	+152°C/W
MSOP .....	+206°C/W

**Electrical Characteristics**

$2.7V \leq V_{DD} \leq 5.5$ ;  $T_A = +25^\circ C$ , **bold** values indicate  $-55^\circ C \leq T_A \leq +125^\circ C$ , **Note 4**; unless noted.

Symbol	Parameter	Condition	Min	Typ	Max	Units
<b>Power Supply</b>						
$I_{DD}$	Supply Current	/INT, open, A0 = $V_{DD}$ or GND, CLK = DATA = high, normal mode		350	<b>750</b>	$\mu A$
		/INT, open, A0 = $V_{DD}$ or GND, shutdown mode, CLK = 100kHz		3		$\mu A$
		/INT, open, A0 = $V_{DD}$ or GND, shutdown mode, CLK = DATA = high		1	<b>10</b>	$\mu A$
$t_{POR}$	Power-On Reset Time; <b>Note 7</b>	$V_{DD} > V_{POR}$			<b>200</b>	$\mu s$
$V_{POR}$	Power-On Reset Voltage	all registers reset to default values, A/D conversions initiated		2.0	2.7	V
$V_{HYST}$	Power-On Reset Hysteresis Voltage			250		mV
<b>Temperature-to-Digital Converter Characteristics</b>						
	Accuracy—Local Temperature <b>Note 4, 9</b> $3V \leq V_{DD} \leq 3.6V$	$0^\circ C \leq T_A \leq +100^\circ C$ , /INT open, $3V \leq V_{DD} \leq 3.6V$		$\pm 1$	<b><math>\pm 2</math></b>	$^\circ C$
		$-55^\circ C \leq T_A \leq +125^\circ C$ , /INT open,		$\pm 2$	<b><math>\pm 3</math></b>	$^\circ C$
	Accuracy—Remote Temperature <b>Note 5, 4, 9</b> $3V \leq V_{DD} \leq 3.6V$ , $0^\circ C \leq T_A \leq +85^\circ C$	$0^\circ C \leq T_D \leq +100^\circ C$ , /INT open, $3V \leq V_{DD} \leq 3.6V$ , $0^\circ C \leq T_A \leq +85^\circ C$		$\pm 1$	<b><math>\pm 3</math></b>	$^\circ C$
		$-55^\circ C \leq T_D \leq +125^\circ C$ , /INT open,		$\pm 2$	<b><math>\pm 5</math></b>	$^\circ C$
$t_{CONV0}$	Conversion Time, local zone <b>Note 7, 8</b>			50	<b>80</b>	ms
$t_{CONV1}$	Conversion Time, remote zone Note 7, 8			100	<b>160</b>	ms
<b>Remote Temperature Inputs (T1, T2)</b>						
$I_F$	Current to External Diode <b>Note 7</b>	high level, T1 or T2 forced to 1.5V		224	<b>400</b>	$\mu A$
		low level		<b>7.5</b>	14	$\mu A$
<b>Address Input (A0)</b>						
$V_{IL}$	Low Input Voltage	$2.7V \leq V_{DD} \leq 5.5V$			<b>0.6</b>	V
$V_{IH}$	High Input Voltage	$2.7V \leq V_{DD} \leq 5.5V$		<b>2.0</b>		V
$C_{IN}$	Input Capacitance			10		pF
$I_{LEAK}$	Input Current			$\pm 0.01$	$\pm 1$	$\mu A$

Symbol	Parameter	Condition	Min	Typ	Max	Units
<b>Serial Data I/O Pin (DATA)</b>						
$V_{OL}$	Low Output Voltage <b>Note 6</b>	$I_{OL} = 3\text{mA}$			<b>0.4</b>	V
		$I_{OL} = 6\text{mA}$			<b>0.8</b>	V
$V_{IL}$	Low Input Voltage	$2.7\text{V} \leq V_{DD} \leq 5.5\text{V}$			<b><math>0.3V_{DD}</math></b>	V
$V_{IH}$	High Input Voltage	$2.7\text{V} \leq V_{DD} \leq 5.5\text{V}$	<b><math>0.7V_{DD}</math></b>			V
$C_{IN}$	Input Capacitance			10		pF
$I_{LEAK}$	Input current			$\pm 0.01$	$\pm 1$	$\mu\text{A}$
<b>Serial Clock Input (CLK)</b>						
$V_{IL}$	Low Input Voltage	$2.7\text{V} \leq V_{DD} \leq 5.5\text{V}$			<b><math>0.3V_{DD}</math></b>	V
$V_{IH}$	High Input Voltage	$2.7\text{V} \leq V_{DD} \leq 5.5\text{V}$	<b><math>0.7V_{DD}</math></b>			V
$C_{IN}$	Input Capacitance			10		pF
$I_{LEAK}$	Input current			$\pm 0.01$	$\pm 1$	$\mu\text{A}$
<b>Status Output (/INT)</b>						
$V_{OL}$	Low Output Voltage, <b>Note 6</b>	$I_{OL} = 3\text{mA}$			<b>0.4</b>	V
		$I_{OL} = 6\text{mA}$			<b>0.8</b>	V
$t_{INT}$	Interrupt Propagation Delay, <b>Note 7, 8</b>	from $TEMPx > T_{SETx}$ or $TEMPx < T_{HYSTx}$ to $/INT < V_{OL}$ , $FQ = 00$ , $R_{PULLUP} = 10\text{k}\Omega$			<b><math>t_{CONV}+1</math></b>	$\mu\text{s}$
$t_{nINT}$	Interrupt Reset Propagation Delay, <b>Note 7</b>	from any register read to $/INT > V_{OH}$ , $R_{PULLUP} = 10\text{k}\Omega$			<b>1</b>	$\mu\text{s}$
$T_{SET0}$	Default $T_{SET0}$ Value	$t_{POR}$ after $V_{DD} > V_{POR}$	81	81	81	$^{\circ}\text{C}$
$T_{HYST0}$	Default $T_{HYST0}$ Value	$t_{POR}$ after $V_{DD} > V_{POR}$	76	76	76	$^{\circ}\text{C}$
$T_{SET1}$	Default $T_{SET1}$ Value	$t_{POR}$ after $V_{DD} > V_{POR}$	97	97	97	$^{\circ}\text{C}$
$T_{HYST1}$	Default $T_{HYST1}$ Value	$t_{POR}$ after $V_{DD} > V_{POR}$	92	92	92	$^{\circ}\text{C}$
$T_{SET2}$	Default $T_{SET2}$ Value	$t_{POR}$ after $V_{DD} > V_{POR}$	97	97	97	$^{\circ}\text{C}$
$T_{HYST2}$	Default $T_{HYST2}$ Value	$t_{POR}$ after $V_{DD} > V_{POR}$	92	92	92	$^{\circ}\text{C}$
<b>Serial Interface Timing (Note 7)</b>						
$t_1$	CLK (Clock) Period		<b>2.5</b>			$\mu\text{s}$
$t_2$	Data In Setup Time to CLK High		<b>100</b>			ns
$t_3$	Data Out Stable After CLK Low		<b>0</b>			ns
$t_4$	DATA Low Setup Time to CLK Low	start condition	<b>100</b>			ns
$t_5$	DATA High Hold Time After CLK High	stop condition	<b>100</b>			ns

**Note 1.** Exceeding the absolute maximum rating may damage the device.

**Note 2.** The device is not guaranteed to function outside its operating rating.

**Note 3.** Devices are ESD sensitive. Handling precautions recommended.  
Human body model: 1.5k in series with 100pF. Machine model: 200pF, no series resistance.

**Note 4.** Final test on outgoing product is performed at  $T_A = \text{TBD}^{\circ}\text{C}$ .

**Note 5.**  $T_D$  is the temperature of the remote diode junction. Testing is performed using a single unit of one of the transistors listed in Table 6.

**Note 6.** Current into this pin will result in self-heating of the MIC384. Sink current should be minimized for best accuracy.

**Note 7.** Guaranteed by design over the operating temperature range. Not 100% production tested.

**Note 8.**  $t_{CONV} = t_{CONV0} + (2 \times t_{CONV1})$ .  $t_{CONV0}$  is the conversion time for the local zone;  $t_{CONV1}$  is the conversion time for the remote zones.

**Note 9.** Accuracy specification does not include quantization noise, which may be as great as  $\pm 1/2\text{LSB}$  ( $\pm 0.5^{\circ}\text{C}$ ).

## Timing Diagram

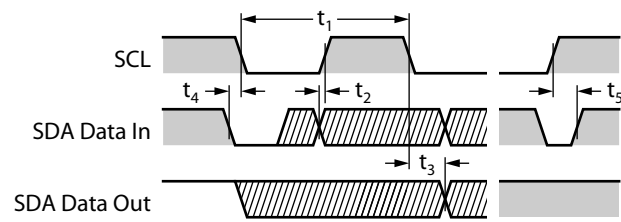

**Serial Interface Timing**

## Functional Diagram

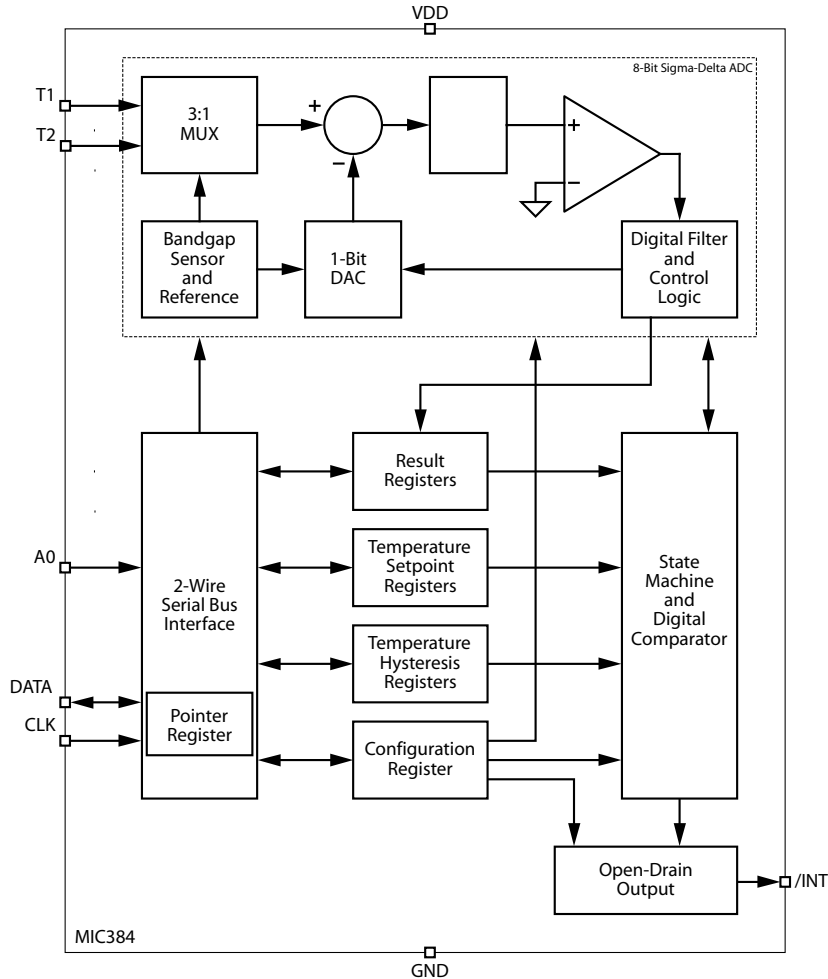

## Functional Description

### Pin Descriptions

**VDD:** Power supply input. See electrical specifications.

**GND:** Ground return for all MIC384 functions.

**CLK:** Clock input to the MIC384 from the two-wire serial bus. The clock signal is provided by the host, and is shared by all devices on the bus.

**DATA:** Serial data I/O pin that connects to the two-wire serial bus. DATA is bi-directional and has an open-drain output driver. An external pull-up resistor or current source somewhere in the system is necessary on this line. This line is shared by all devices on the bus.

**A0:** This inputs sets the least significant bit of the MIC384's 7-bit slave address. The six most-significant bits are fixed and are determined by the part number ordered. (See ordering information table above.) Each MIC384 will only respond to its own unique slave address, allowing up to eight MIC384's to share a single bus. A match between the MIC384's address and the address specified in the serial bit stream must be made to initiate communication. A0 should be tied directly to VDD or ground. See "Temperature Measurement and

Power On" for more information. A0 determines the slave address as shown in Table 1:

Part Number	Inputs	MIC384 Slave Address	
	A0	Binary	Hex
MIC384-0	0	100 1000 <sub>b</sub>	48 <sub>h</sub>
	1	100 1001 <sub>b</sub>	49 <sub>h</sub>
MIC384-1	0	100 1010 <sub>b</sub>	4A <sub>h</sub>
	1	100 1011 <sub>b</sub>	4B <sub>h</sub>
MIC384-2	0	100 1100 <sub>b</sub>	4C <sub>h</sub>
	1	100 1101 <sub>b</sub>	4D <sub>h</sub>
MIC384-3	0	100 1110 <sub>b</sub>	4E <sub>h</sub>
	1	100 1111 <sub>b</sub>	4F <sub>h</sub>

**Table 1. MIC384 Slave Address Settings**

**/INT:** Temperature events are indicated to external circuitry via this output. Operation of the /INT output is controlled by the MODE and IM bits in the MIC384's configuration register. See "Comparator and Interrupt Modes" below. This output is open-drain and may be wire-OR'ed with other open-drain signals. Most systems will require a pull-up resistor or current source on this pin. If the IM bit in the configuration register

is set, it prevents the /INT output from sinking current. In I<sup>2</sup>C and SMBus systems, the IM bit is therefore an interrupt mask bit.

**T1 and T2:** The T1 and T2 pins connect to off-chip PN diode junctions, for monitoring the temperature at remote locations. The remote diodes may be embedded thermal sensing junctions in integrated circuits so equipped (such as Intel's Pentium III), or discrete 2N3906-type bipolar transistors with base and collector tied together.

### Temperature Measurement

The temperature-to-digital converter is built around a switched current source and an eight-bit analog-to-digital converter. The temperature is calculated by measuring the forward voltage of a diode junction at two different bias current levels. An internal multiplexer directs the current source's output to either the internal or one of the external diode junctions. The MIC384 uses two's-complement data to represent temperatures. If the MSB of a temperature value is zero, the temperature is zero or positive. If the MSB is one, the temperature is negative. More detail on this is given in the "Temperature Data Format" section below. A "temperature event" results if the value in any of the temperature result registers (TEMPx) becomes greater than the value in the corresponding temperature setpoint register (T\_SETx). Another temperature event occurs if and when the measured temperature subsequently falls below the temperature hysteresis setting in T\_HYSTx.

During normal operation the MIC384 continuously performs temperature-to-digital conversions, compares the results against the setpoint and hysteresis registers, and updates the state of /INT and the status bits accordingly. The remote zones are converted first, followed by the local zone (T1⇒T2⇒LOCAL). The states of /INT and the status bits are updated after each measurement is taken.

### Diode Faults

The MIC384 is designed to respond in a failsafe manner to hardware faults in the external sensing circuitry. If the connection to an external diode is lost or the sense line (T1 or T2) is shorted to V<sub>DD</sub> or ground, the temperature data reported by the A/D converter will be forced to its full-scale value (+127°C). This will cause a temperature event to occur if the setpoint register for the corresponding zone is set to any value less than 127°C (7F<sub>h</sub> = 0111 1111<sub>b</sub>). An interrupt will be generated on /INT if so enabled. The temperature

reported for the external zone will remain +127°C until the fault condition is cleared. This fault detection mechanism requires that the MIC384 complete the number of conversion cycles specified by Fault\_Queue (see below). The part will therefore require one or more conversion cycles following power-on or a transition from shutdown to normal operation before reporting an external diode fault.

### Serial Port Operation

The MIC384 uses standard SMBus Write\_Byte and Read\_Byte operations for communication with its host. The SMBus Write\_Byte operation involves sending the device's slave address (with the R/W bit low to signal a write operation), followed by a command byte and a data byte. The SMBus Read\_Byte operation is similar, but is a composite write and read operation: the host first sends the device's slave address followed by the command byte, as in a write operation. A new start bit must then be sent to the MIC384, followed by a repeat of the slave address with the R/W bit (LSB) set to the high (read) state. The data to be read from the part may then be clocked out.

The command byte is eight bits wide. This byte carries the address of the MIC384 register to be operated upon, and is stored in the part's pointer register. The pointer register is an internal write-only register. The command byte (pointer register) values corresponding to the various MIC384 registers are shown in Table 2. Command byte values other than those explicitly shown are reserved, and should not be used. Any command byte sent to the MIC384 will persist in the pointer register indefinitely until it is overwritten by another command byte. If the location latched in the pointer register from the last operation is known to be correct (i.e., points to the desired register), then the Receive\_Byte procedure may be used. To perform a Receive\_Byte, the host sends an address byte to select the MIC384, and then retrieves the data byte. Figures 1 through 3 show the formats for these procedures.

Command_Byte		Target Register	
Binary	Hex	Label	Description
0000 0000 <sub>b</sub>	00 <sub>h</sub>	TEMP0	local temperature
0000 0001 <sub>b</sub>	01 <sub>h</sub>	CONFIG	configuration register
0000 0010 <sub>b</sub>	02 <sub>h</sub>	T_HYST0	local temperature hysteresis
0000 0011 <sub>b</sub>	03 <sub>h</sub>	T_SET0	local temperature setpoint
0001 0000 <sub>b</sub>	10 <sub>h</sub>	TEMP1	remote zone 1 temperature
0001 0010 <sub>b</sub>	12 <sub>h</sub>	T_HYST1	remote zone 1 temperature hysteresis
0001 0011 <sub>b</sub>	13 <sub>h</sub>	T_SET1	remote zone 1 temperature setpoint
0010 0000 <sub>b</sub>	20 <sub>h</sub>	TEMP2	remote zone 2 temperature
0010 0010 <sub>b</sub>	22 <sub>h</sub>	T_HYST2	remote zone 2 temperature hysteresis
0010 0011 <sub>b</sub>	23 <sub>h</sub>	T_SET2	remote zone 2 temperature setpoint

**Table 2. MIC384 Register Addresses**





## Temperature Data Format

The LSB of each register represents one degree Centigrade. The values are in a two's complement format, wherein the most significant bit (D7) represents the sign: zero for positive temperatures and one for negative temperatures. Table 3 shows examples of the data format used by the MIC384 for temperatures.

## A/D Converter Timing

Whenever the MIC384 is not in its low power shutdown mode, the internal A/D converter (ADC) attempts to make continuous conversions unless interrupted by a bus transaction accessing the MIC384.

Upon powering up or coming out of shutdown mode, the ADC will begin acquiring temperature data starting with the first external zone, zone 1, then the second external zone, zone 2, and finally the internal zone, zone 0. Results for zone 1 will be valid after  $t_{CONV1}$ , results for zone two will be ready after another  $t_{CONV1}$ , and for the local zone  $t_{CONV0}$  later. Figure 4 shows this behavior. The conversion time is twice as long for external conversions as it is for internal conversions. This allows the use of a filter capacitor on T1 and/or T2 without a loss of accuracy due to the resulting longer settling times.

Upon powering up, coming out of shutdown mode, or resuming operation following a serial bus transaction, the ADC will begin acquiring temperature data with the first external zone (zone 1), followed by the second external zone (zone 2), and then the internal zone (zone 0). If the ADC is interrupted by a serial bus transaction, it will restart the conversion that was interrupted and then continue in the normal sequence. This sequence will repeat indefinitely until the MIC384 is shut down, powered off, or is interrupted by a serial bus transaction as described above.

## Power On

When power is initially applied, the MIC384's internal registers are set to their default states. Also at this time, the level on the address input, A0, is read to establish the device's slave address. The MIC384's power-up default state can be summarized as follows:

- Normal mode operation (i.e., part is not in shutdown)
- /INT function is set to comparator mode
- Fault queue depth = 1 (FQ=00)
- Interrupts are enabled (IM = 0)
- T\_SET0 = 81°C; T\_HYST0 = 76°C
- T\_SET1 = 97°C; T\_HYST1 = 92°C
- T\_SET2 = 97°C; T\_HYST2 = 92°C
- Initialized to recognize overtemperature faults

## Comparator and Interrupt Modes

Depending on the setting of the MODE bit in the configuration register, the /INT output will behave either as an interrupt request signal or a thermostatic control signal. Thermostatic operation is known as *comparator mode*. The /INT output is asserted when the measured temperature, as reported in any of the TEMPx registers, exceeds the threshold programmed into the corresponding T\_SETx register for the number of conversions specified by Fault\_Queue (described below). In comparator mode, /INT will remain asserted and the status bit(s) will remain high unless and until the measured temperature falls below the value in the T\_HYSTx register for Fault\_Queue conversions. No action on the part of the host is required for operation in comparator mode. Note that entering shutdown mode will not affect the state of /INT when the device is in comparator mode.

In *interrupt mode*, once a temperature event has caused a status bit to be set and the /INT output to be asserted, they will not be automatically de-asserted when the measured temperature falls below T\_HYSTx. They can only be de-asserted by reading any of the MIC384's internal registers or by putting the device into shutdown mode. If the most recent temperature event was an overtemperature condition, Sx will not be set again, and /INT cannot be reasserted, until the device has detected that TEMPx < T\_HYSTx. Similarly, if the most recent temperature event was an undertemperature condition, Sx will not be set again, and /INT cannot be reasserted, until the device has detected that TEMPx > T\_SETx. This keeps the internal logic of the MIC384 backward compatible with that of the LM75 and similar devices. In both modes, the MIC384 will be responsive to over-temperature events at power-up. See "Interrupt Generation", below.

## Shutdown Mode

Setting the SHDN bit in the configuration register halts the otherwise continuous conversions by the A/D converter. The MIC384's power consumption drops to 1  $\mu$ A typical in shutdown mode. All registers may be read from or written to while in shutdown mode. Serial bus activity will slightly increase the part's power consumption.

Entering shutdown mode will not affect the state of /INT when the device is in comparator mode (MODE = 0). It will retain its state until after the device exits shutdown mode and resumes A/D conversions.

However, if the device is shut down while in interrupt mode, the /INT pin will be unconditionally de-asserted and the internal latches holding the interrupt status will be cleared. Therefore, no interrupts will be generated while the MIC384 is in

Temperature	Binary	Hex
+125° C	0111 1101 <sub>b</sub>	7D <sub>h</sub>
+100° C	0110 0100 <sub>b</sub>	64 <sub>h</sub>
+25° C	0001 1001 <sub>b</sub>	19 <sub>h</sub>
+1.0° C	0000 0001 <sub>b</sub>	01 <sub>h</sub>
0° C	0000 0000 <sub>b</sub>	00 <sub>h</sub>
- 1.0° C	1111 1111 <sub>b</sub>	FF <sub>h</sub>
- 25° C	1110 0111 <sub>b</sub>	E7 <sub>h</sub>
- 40° C	1101 1000 <sub>b</sub>	D8 <sub>h</sub>
- 55° C	1100 1001 <sub>b</sub>	C9 <sub>h</sub>

**Table 3. Digital Temperature Format**

shutdown mode, and the interrupt status will not be retained. Since entering shutdown mode stops A/D conversions, the MIC384 is incapable of detecting or reporting temperature events of any kind while in shutdown. Diode faults require one or more A/D conversion cycles to be recognized, and therefore will not be reported either while the device is in shutdown (see "Diode Faults" above).

### Fault\_Queue

Fault queues (programmable digital filters) are provided in the MIC384 to prevent false tripping due to thermal or electrical noise. The two bits in CONFIG[4:3] set the depth of Fault\_Queue. Fault\_Queue then determines the number of consecutive temperature events ( $TEMP_x > T\_SET_x$ , or  $TEMP_x < T\_HYST_x$ ) which must occur in order for the condition to be considered valid. There are separate fault queues for each zone. As an example, assume the part is in comparator mode, and CONFIG[4:3] is programmed with  $10_b$ . The measured temperature in zone one would have to exceed  $T\_SET1$  for four consecutive A/D conversions before /INT would be asserted or the S1 status bit set. Similarly,  $TEMP1$  would then have to be less than  $T\_HYST1$  for four consecutive conversions before /INT would be reset. Like any filter, the fault queue function also has the effect of delaying the detection of temperature events. In this example, it would take  $4 \times t_{CONV}$  to detect a temperature event. The depth of Fault\_Queue vs. D[4:3] of the configuration register is shown in Table 4.

CONFIG[4:3]	Fault_Queue Depth
00	1 conversion*
01	2 conversions
10	4 conversions
11	6 conversions

\* Default setting

**Table 4. Fault\_Queue Depth Settings**

### Interrupt Generation

Assuming the MIC384 is in interrupt mode and interrupts are enabled, there are seven different conditions that will cause the MIC384 to set one of the status bits, S0, S1, or

S2, in CONFIG and assert its /INT output. These conditions are listed in Table 5. When a temperature event occurs, the corresponding status bit will be set in CONFIG. This action cannot be masked. However, a temperature event will only generate an interrupt signal on /INT if it is specifically enabled by the interrupt mask bit (IM = 0 in CONFIG). Following an interrupt, the host should read the contents of the configuration register to confirm that the MIC384 was the source of the interrupt. A read operation on *any register will cause /INT to be de-asserted. This is shown in Figure 5. The status bits will only be cleared once CONFIG has been read.*

*Since temperature-to-digital conversions continue while /INT is asserted, the measured temperature could change between the MIC384's assertion of /INT and the host's response. It is good practice for the interrupt service routine to read the value in TEMP<sub>x</sub>, to verify that the over-temperature or under-temperature condition still exists. In addition, more than one temperature event may have occurred simultaneously or in rapid succession between the assertion of /INT and servicing of the MIC384 by the host. The interrupt service routine should allow for this eventuality. Keep in mind that clearing the status bits and deasserting /INT is not sufficient to allow further interrupts to occur. TEMP<sub>x</sub> must become less than T<sub>HYSTx</sub> if the last event was an over-temperature condition, or greater than T<sub>SETx</sub> if the last event was an under-temperature condition, before /INT can be asserted again.*

*Putting the device into shutdown mode will de-assert /INT and clear the status bits (S0, S1, and S2). This should not be done before completing the appropriate interrupt service routine(s).*

### Polling

The MIC384 may either be polled by the host, or request the host's attention via the /INT pin. In the case of polled operation, the host periodically reads the contents of CONFIG to check the state of the status bits. The act of reading CONFIG clears the status bits. If more than one event that sets a given status bit occurs before the host polls the MIC384, only the fact that at least one such event has occurred will be apparent to the host. For polled systems, the interrupt mask bit should be set (IM = 1). This will disable interrupts from the MIC384 and prevent the /INT pin from sinking current.

Event	Condition*	MIC384 response**
high temperature, local	TEMP0 > T_SET0	set S0 in CONFIG, assert /INT
high temperature, remote zone 1	TEMP1 > T_SET1	set S1 in CONFIG, assert /INT
high temperature, remote zone 2	TEMP2 > T_SET2	set S2 in CONFIG, assert /INT
low temperature, local	TEMP0 < T_HYST0	set S0 in CONFIG, assert /INT
low temperature, remote zone 1	TEMP1 < T_HYST1	set S1 in CONFIG, assert /INT
low temperature, remote zone 2	TEMP2 < T_HYST2	set S2 in CONFIG, assert /INT
diode fault	T1 or T2 open or shorted to VDD or GND	set S1 and/or S2 in CONFIG, assert /INT and /CRIT***

\* Condition must be true for FAULT\_QUEUE conversion to be recognized

\*\* Assumes interrupts enabled

\*\*\* Assumes the T\_SET1 and/or CRIT1 are set to any value less than +127° C = 7f<sub>h</sub> = 0111 1111<sub>b</sub>

**Table 5. MIC384 Temperature Events**

## Register Set and Programmer's Model

### Internal Register Set

Name	Description	Command Byte	Operation	Power-Up Default
TEMP0	measured temperature, local zone	00 <sub>h</sub>	8-bit read only	00 <sub>h</sub> (0° C) <sup>(1)</sup>
CONFIG	configuration register	01 <sub>h</sub>	8-bit read/write	00 <sub>h</sub> <sup>(2)</sup>
T_HYST0	hysteresis setting, local zone	02 <sub>h</sub>	8-bit read/write	4C <sub>h</sub> (+76° C)
T_SET0	temperature setpoint, local zone	03 <sub>h</sub>	8-bit read/write	51 <sub>h</sub> (+81° C)
TEMP1	measured temperature, zone 1	10 <sub>h</sub>	8-bit read only	00 <sub>h</sub> (0° C) <sup>(1)</sup>
T_HYST1	hysteresis setting, zone 1	12 <sub>h</sub>	8-bit read/write	5C <sub>h</sub> (+92° C)
T_SET1	temperature setpoint, zone 1	13 <sub>h</sub>	8-bit read/write	61 <sub>h</sub> (+97° C)
TEMP2	measured temperature, zone 2	20 <sub>h</sub>	8-bit read only	00 <sub>h</sub> (0° C) <sup>(1)</sup>
T_HYST2	hysteresis setting, zone 2	22 <sub>h</sub>	8-bit read/write	5C <sub>h</sub> (+92° C)
T_SET2	temperature setpoint, zone 2	23 <sub>h</sub>	8-bit read/write	61 <sub>h</sub> (+97° C)

- (1) TEMPx will contain measured temperature data after the completion of one conversion cycle.  
 (2) After the first Fault\_Queue conversions are complete, status bits will be set if TEMPx > T\_SETx.

### Detailed Register Descriptions

#### Configuration Register

CONFIGURATION REGISTER (CONFIG)							
8-Bit Read/Write							
D[7]	D[6]	D[5]	D[4]	D[3]	D[2]	D[1]	D[0]
read only	read only	read only	read/write		read/write	read/write	read/write
local status (S0)	remote status (S1)	/CRIT status (CRIT1)	fault queue depth (FQ[1:0])		interrupt mask (IM)	CMP/INT mode (MODE)	Shutdown (SHDN)

Bits	Function	Operation
S0	local interrupt status (read only)	1 = event occurred, 0 = no event
S1	remote interrupt status (read only)	1 = event occurred, 0 = no event
CRIT1	remote over-temperature status (read only)	1 = over-temperature, 0 = no event
FQ[1:0]	Fault_Queue depth	00 = 1 conversion, 01 = 2 conversions, 10 = 4 conversions, 11 = 6 conversions
IM	interrupt mask	1 = disabled, 0 = interrupts enabled
MODE	comparator/interrupt mode selection for /INT pin	1 = interrupt mode, 0 = comparator mode
SHDN	normal/shutdown operating mode selection	1 = shutdown, 0 = normal

CONFIG Power-Up Value: 0000 0000<sub>b</sub> = 00<sub>h</sub><sup>(\*)</sup>

- not in shutdown mode
- comparator mode
- Fault\_Queue depth = 1
- interrupts enabled.
- no temperature events pending

CONFIG Command Byte Value: 0000 0001<sub>b</sub> = 01<sub>h</sub>

\* Following the first Fault\_Queue conversions, one or more of the status bits may be set.

**Local Temperature Result Register**

LOCAL TEMPERATURE RESULT REGISTER (TEMP0)							
8-Bit Read/Write							
D[7]	D[6]	D[5]	D[4]	D[3]	D[2]	D[1]	D[0]
MSB	bit 6	bit 5	bit 4	bit 3	bit 2	bit 1	LSB
temperature data from ADC*							
Bits	Function			Operation			
D[7:0]	measured temperature data for the local zone*			read only			

TEMP0 Power-Up Value:  $0000\ 0000_b = 00_h$  ( $0^\circ\text{C}$ )<sup>†</sup>

TEMP0 Command Byte Value:  $0000\ 0000_b = 00_h$

\* Each LSB represents one degree Centigrade. The values are in a two's complement format such that  $0^\circ\text{C}$  is reported as  $0000\ 0000_b$ . See "Temperature Data Format" for more details.

<sup>†</sup> TEMP0 will contain measured temperature data after the completion of one conversion.

**Local Hysteresis Register**

LOCAL TEMPERATURE HYSTERESIS (T_HYST0)							
8-Bit Read/Write							
D[7]	D[6]	D[5]	D[4]	D[3]	D[2]	D[1]	D[0]
MSB	bit 6	bit 5	bit 4	bit 3	bit 2	bit 1	LSB
local temperature hysteresis setting							
Bits	Function			Operation			
D[7:0]	local temperature hysteresis setting*			read/write			

T\_HYST0 Power-Up Value:  $0100\ 1100_b = 4C_h$  ( $+76^\circ\text{C}$ )

T\_HYST0 Command Byte Value:  $0000\ 0010_b = 02_h$

\* Each LSB represents one degree Centigrade. The values are in a two's complement format such that  $0^\circ\text{C}$  is reported as  $0000\ 0000_b$ . See "Temperature Data Format" for more details.

**Local Temperature Setpoint Register**

LOCAL TEMPERATURE SETPOINT (T_SET0)							
8-Bit Read/Write							
D[7]	D[6]	D[5]	D[4]	D[3]	D[2]	D[1]	D[0]
MSB	bit 6	bit 5	bit 4	bit 3	bit 2	bit 1	LSB
local temperature setpoint							
Bits	Function			Operation			
D[7:0]	local temperature setpoint*			read/write			

T\_SET0 Power-Up Value:  $0101\ 0001_b = 51_h$  ( $+81^\circ\text{C}$ )

T\_SET0 Command Byte Value:  $0000\ 0011_b = 03_h$

\* Each LSB represents one degree Centigrade. The values are in a two's complement format such that  $0^\circ\text{C}$  is reported as  $0000\ 0000_b$ . See "Temperature Data Format" for more details.

**Remote Zone 1 Temperature Result Register**

REMOTE ZONE 1 TEMPERATURE RESULT (TEMP1) 8-Bit Read Only							
D[7]	D[6]	D[5]	D[4]	D[3]	D[2]	D[1]	D[0]
MSB	bit 6	bit 5	bit 4	bit 3	bit 2	bit 1	LSB
remote zone 1 temperature data from ADC*							
Bits	Function			Operation			
D[7:0]	measured temperature data for remote zone one*			read only			

TEMP1 Power-Up Value:  $0000\ 0000_b = 00_h (0^\circ\text{C})^\dagger$

TEMP1 Command Byte Value:  $0001\ 0000_b = 10_h$

\* Each LSB represents one degree Centigrade. The values are in a two's complement format such that  $0^\circ\text{C}$  is reported as  $0000\ 0000_b$ . See "Temperature Data Format" for more details.

† TEMP1 will contain measured temperature data for the selected zone after the completion of one conversion.

**Remote Zone 1 Hysteresis Register**

REMOTE ZONE 1 TEMPERATURE HYSTERESIS REGISTER (T_HYST1) 8-Bit Read/Write							
D[7]	D[6]	D[5]	D[4]	D[3]	D[2]	D[1]	D[0]
MSB	bit 6	bit 5	bit 4	bit 3	bit 2	bit 1	LSB
remote zone 1 temperature hysteresis*							
Bits	Function			Operation			
D[7:0]	remote zone one temperature hysteresis*			read/write			

T\_HYST1 Power-Up Value:  $0101\ 1100_b = 5C_h (+92^\circ\text{C})$

T\_HYST1 Command Byte Value:  $0001\ 0010_b = 12_h$

\* Each LSB represents one degree Centigrade. The values are in a two's complement format such that  $0^\circ\text{C}$  is reported as  $0000\ 0000_b$ . See "Temperature Data Format" for more details.

**Remote Zone 1 Temperature Setpoint Register**

REMOTE ZONE 1 TEMPERATURE SETPOINT (T_SET1) 8-Bit Read/Write							
D[7]	D[6]	D[5]	D[4]	D[3]	D[2]	D[1]	D[0]
MSB	bit 6	bit 5	bit 4	bit 3	bit 2	bit 1	LSB
remote zone 1 temperature setpoint							
Bits	Function			Operation			
D[7:0]	remote zone one temperature setpoint*			read/write			

T\_SET1 Power-Up Value:  $0110\ 0001_b = 61_h (+97^\circ\text{C})$

T\_SET1 Command Byte Value:  $0001\ 0011_b = 13_h$

\* Each LSB represents one degree Centigrade. The values are in a two's complement format such that  $0^\circ\text{C}$  is reported as  $0000\ 0000_b$ . See "Temperature Data Format" for more details.

**Remote Zone 2 Temperature Result Register**

REMOTE ZONE 2 TEMPERATURE RESULTS REGISTER (TEMP2)							
8-Bit Read Only							
D[7]	D[6]	D[5]	D[4]	D[3]	D[2]	D[1]	D[0]
MSB	bit 6	bit 5	bit 4	bit 3	bit 2	bit 1	LSB
remote zone 2 temperature data from ADC*							
Bits	Function			Operation			
D[7:0]	measured temperature data for remote zone 2*			read only			

TEMP2 Power-Up Value:  $0000\ 0000_b = 00_h (0^\circ\text{C})^\dagger$ TEMP2 Command Byte Value:  $0010\ 0000_b = 20_h$ 

\* Each LSB represents one degree Centigrade. The values are in a two's complement format such that  $0^\circ\text{C}$  is reported as  $0000\ 0000_b$ . See "Temperature Data Format" for more details.

† TEMP2 will contain measured temperature data for the selected zone after the completion of one conversion.

**Remote Zone 2 Hysteresis Register**

REMOTE ZONE 2 HYSTERESIS REGISTER (T_HYST2)							
8-Bit Read/Write							
D[7]	D[6]	D[5]	D[4]	D[3]	D[2]	D[1]	D[0]
MSB	bit 6	bit 5	bit 4	bit 3	bit 2	bit 1	LSB
remote zone 2 temperature hysteresis setting							
Bits	Function			Operation			
D[7:0]	remote zone 2 temperature hysteresis setting*			read/write			

T\_HYST2 Power-Up Value:  $0101\ 1100_b = 5C_h (+92^\circ\text{C})$ T\_HYST2 Command Byte Value:  $0010\ 0010_b = 22_h$ 

\* Each LSB represents one degree Centigrade. The values are in a two's complement format such that  $0^\circ\text{C}$  is reported as  $0000\ 0000_b$ . See "Temperature Data Format" for more details.

**Remote Zone 2 Setpoint Register**

REMOTE ZONE 2 TEMPERATURE SETPOINT (T_SET2)							
8-Bit Read/Write							
D[7]	D[6]	D[5]	D[4]	D[3]	D[2]	D[1]	D[0]
MSB	bit 6	bit 5	bit 4	bit 3	bit 2	bit 1	LSB
remote zone 2 temperature setpoint							
Bits	Function			Operation			
D[7:0]	remote zone 2 temperature setpoint*			read/write			

T\_SET2 Power-Up Value:  $0110\ 0001_b = 61_h (+97^\circ\text{C})$ T\_SET2 Command Byte Value:  $0010\ 0011_b = 23_h$ 

\* Each LSB represents one degree Centigrade. The values are in a two's complement format such that  $0^\circ\text{C}$  is reported as  $0000\ 0000_b$ . See "Temperature Data Format" for more details.

## Applications

### Remote Diode Selection

Most small-signal PNP transistors with characteristics similar to the JEDEC 2N3906 will perform well as remote temperature sensors. Table 6 lists several examples of such parts that Micrel has tested for use with the MIC384. Other transistors equivalent to these should also work well.

### Minimizing Errors

#### Self-Heating

One concern when using a part with the temperature accuracy and resolution of the MIC384 is to avoid errors in measuring the local temperature induced by self-heating. Self-heating is caused by the power naturally dissipated inside the device due to operating supply current and I/O sink currents ( $V_{DD} \times I_{DD} + V_{OL} \times I_{OL}$ ). In order to understand what level of error this represents, and how to reduce that error, the dissipation in the MIC384 must be calculated and its effects reduced to a temperature offset.

The worst-case operating condition for the MIC384 is when  $V_{DD} = 5.5V$ , MSOP-08 package. The maximum power dissipated in the part is given in Equation 1 below.

In most applications, the /INT output will be low for at most a few milliseconds before the host resets it back to the high state, making its duty cycle low enough that its contribution to self-heating of the MIC384 is negligible. Similarly, the DATA pin will in all likelihood have a duty cycle of substantially less than 25% in the low state. These considerations, combined with more typical device and application parameters, give a better system-level view of device self-heating in interrupt-mode. This is illustrated in Equation 2.

If the part is to be used in comparator mode, calculations similar to those shown above (accounting for the expected value and duty cycle of  $I_{OL(INT)}$ ) will give a good estimate of the temperature error due to self-heating.

In any application, the best test is to verify performance

against calculation in the final application environment. This is especially true when dealing with systems for which some of the thermal data (e.g., PC board thermal conductivity and ambient temperature) may be poorly defined or unobtainable except by empirical means.

### Series resistance

The operation of the MIC384 depends upon sensing the  $\Delta V_{CB-E}$  of a diode-connected PNP transistor ("diode") at two different current levels. For remote temperature measurements, this is done using external diodes connected between T1, T2 and ground.

Since this technique relies upon measuring the relatively small voltage difference resulting from two levels of current through the external diodes, any resistance in series with those diodes will cause an error in the temperature reading from the MIC384. A good rule of thumb is this: for each ohm in series with a zone's external transistor, there will be a 0.9°C error in the MIC384's temperature measurement. It isn't difficult to keep the series resistance well below an ohm (typically < 0.1Ω), so this will rarely be an issue.

### Filter capacitor selection

It is sometimes desirable to use a filter capacitor between the T1 and/or T2 pins and the GND pin of the MIC384. The use of these capacitors is recommended in environments with a lot of high frequency noise (such as digital switching noise), or if long wires are used to attach to the remote diodes. The maximum recommended total capacitance from the T1 or T2 pin to GND is 2700pF. This typically suggests the use of 2200pF NP0 or C0G ceramic capacitors with a 10% tolerance.

If a remote diode is to be at a distance of more than ≈ 6"—12" from the MIC384, using twisted pair wiring or shielded microphone cable for the connections to the diode can significantly help reduce noise pickup. If using a long run of shielded cable, remember to subtract the cable's conductor-to-shield capacitance from the 2700pF maximum total capacitance.

$$P_D = [(I_{DD} \times V_{DD}) + (I_{OL(DATA)} \times V_{OL(DATA)} + (I_{OL(INT)} \times V_{OL(INT)})]$$

$$P_D = [(0.75mA \times 5.5V) + (6mA \times 0.8V) + (6mA \times 0.8V)]$$

$$P_D = 13.73mW$$

$$R_{q(j-a)} \text{ of MSOP - 08 package is } 206^\circ C/W$$

$$\text{Maximum } \Delta T_J \text{ relative to } T_A \text{ due to self heating is } 13.73mW \times 206^\circ C/W = 2.83^\circ C$$

#### Equation 1. Worst-Case Self-Heating

$$[(0.35mA I_{DD(typ)} \times 3.3V) + (25\% \times 1.5mA I_{OL(DATA)} \times 0.3V) + (1\% \times 1.5mA I_{OL(INT)} \times 0.3V)] = 1.27mW$$

$$\Delta T_J = (1.27mW \times 206^\circ C/W)$$

$$\Delta T_J = 0.262^\circ C$$

#### Equation 2. Real-World Self-heating Example

Vendor	Part Number	Package
Fairchild	MMBT3906	SOT-23
On Semiconductor	MMBT3906L	SOT-23
Phillips Semiconductor	PMBT3906	SOT-23
Samsung	KST3906-TF	SOT-23

**Table 6. Transistors Suitable for Remote Temperature Sensing Use**

## Layout Considerations

The following guidelines should be kept in mind when designing and laying out circuits using the MIC384:

1. Place the MIC384 as close to the remote diodes as possible, while taking care to avoid severe noise sources such as high frequency power transformers, CRTs, memory and data busses, and the like.
2. Since any conductance from the various voltages on the PC Board to the T1 or T2 line can induce serious errors, it is good practice to guard the remote diodes' emitter traces with pairs of ground traces. These ground traces should be returned to the MIC384's own ground pin. They should not be grounded at any other part of their run. However, it is highly desirable to use these guard traces to carry the diodes' own ground return back to the ground pin of the MIC384, thereby providing a Kelvin connection for the base of the diodes. See Figure 6.
3. When using the MIC384 to sense the temperature of a processor or other device which has an integral thermal diode, e.g., Intel's Pentium III, connect the emitter and base of the remote sensor to the MIC384 using the guard traces and Kelvin return shown in Figure 6. The collector of the remote diode is typically inaccessible to the user on these devices. To allow for this, the MIC384 has superb rejection of noise appearing from collector to GND, as long as the base to ground connection is relatively quiet.
4. Due to the small currents involved in the measurement of the remote diode's  $\Delta V_{BE}$ , it is important to adequately clean the PC board after soldering to prevent current leakage. This is most likely to show up as an issue in situations where water-soluble soldering fluxes are used.
5. In general, wider traces for the ground and T1/T2 lines will help reduce susceptibility to radiated noise (wider traces are less inductive). Use trace widths and spacing of 10 mils wherever possible and provide a ground plane under the MIC384 and under the connections from the MIC384 to the remote diodes. This will help guard against stray noise pickup.
6. Always place a good quality 0.1  $\mu\text{F}$  power supply bypass capacitor directly adjacent to, or underneath, the MIC384. Surface-mount capacitors are preferable because of their low inductance.
7. When the MIC384 is being powered from particularly noisy power supplies, or from supplies which may have sudden high-amplitude spikes appearing on them, it can be helpful to add additional power supply filtering. This should be implemented as a 100  $\Omega$  resistor in series with the part's VDD pin, and an additional 4.7  $\mu\text{F}$ , 6.3V electrolytic capacitor from VDD to GND. See Figure 7.

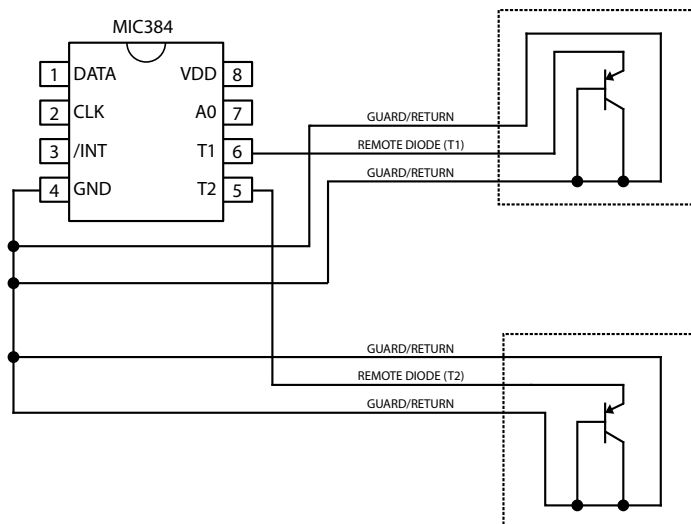

**Figure 6. Guard Traces/Kelvin Ground Returns**

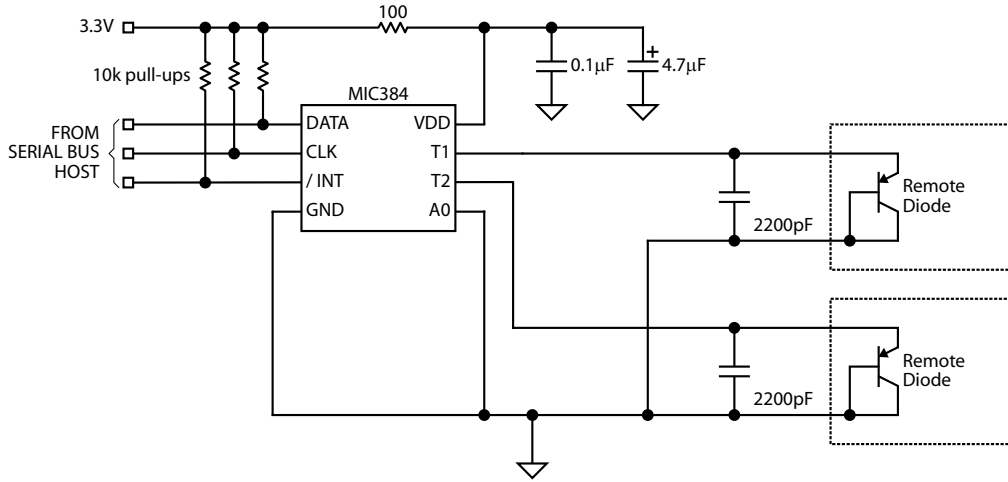
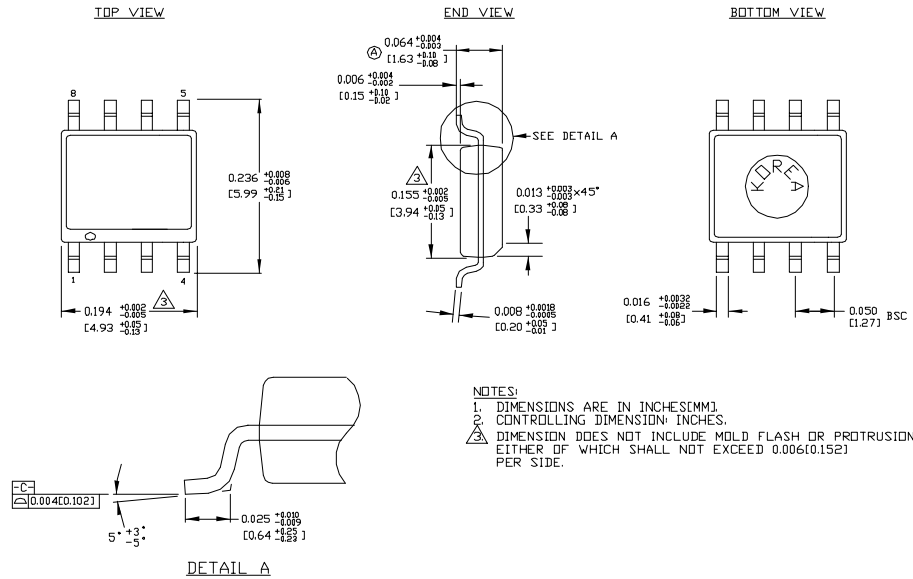
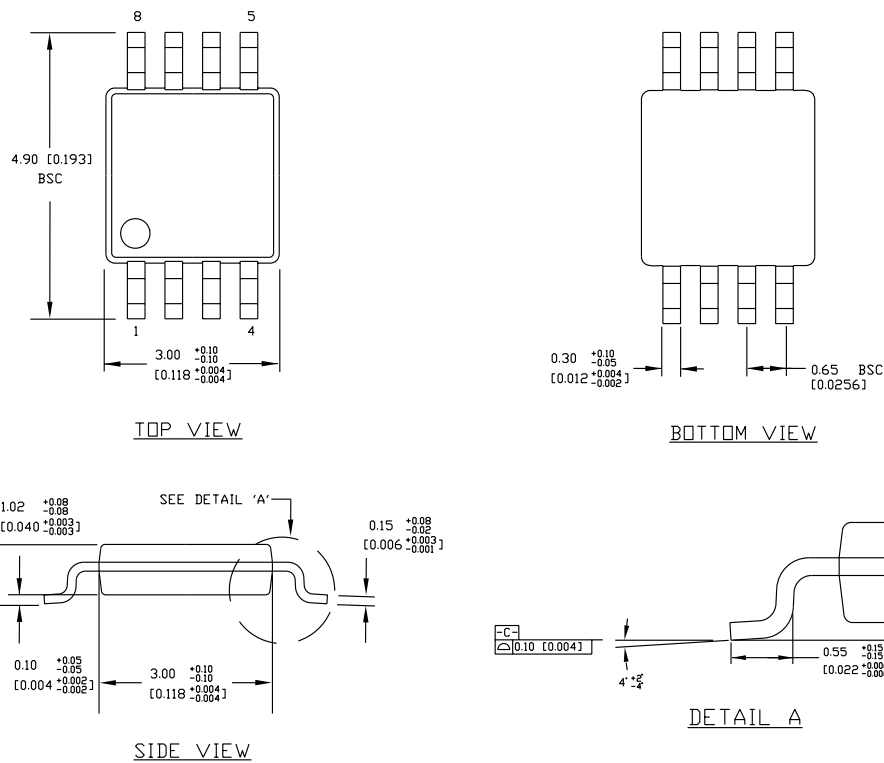

Figure 7. V<sub>DD</sub> Decoupling for Very Noisy Supplies

Package Information



8-Lead SOIC (M)



8-Lead MSOP (MM)

---

**MICREL INC. 2180 FORTUNE DRIVE SAN JOSE, CA 95131 USA**  
TEL + 1 (408) 944-0800 FAX + 1 (408) 474-1000 WEB <http://www.micrel.com>

This information furnished by

Micrel reserves the right to change circuitry and specifications at any time without notification to the customer.

Micrel Products are not

reasonably be expected to result in personal injury. Life support devices or systems are devices or systems that (a) are intended for surgical implant into the body or (b) support or sustain life, and whose failure to perform can be reasonably expected to result in a significant injury to the user. A Purchaser's use or sale of Micrel Pr

Micrel for any damages resulting from such use or sale.

© 2005 Micrel Incorporated

## Looking for pricing, stock, or lifecycle information?

Click below to explore more details on WIN SOURCE:

- ⊖ [View MIC384-3BMM on WIN SOURCE](#)
- ⊖ [Microchip Technology Information](#)

## Optimize Your Supply Chain with WIN SOURCE Solutions

- ✓ Global Sourcing Solution
- ✓ Obsolete Management
- ✓ Cost Control Management
- ✓ Shortage Management
- ✓ Alternative Solution
- ✓ Excess Inventory Management