



**THE DATASHEET OF  
MIC49500WU**





# MIC49500

## 5A Dual Supply, Low Voltage, High Bandwidth LDO

### General Description

The MIC49500 is an ultra-high-bandwidth, low-dropout, 5.0A voltage regulator ideal for powering core voltages of low-voltage microprocessors. The MIC49500 implements a dual supply configuration allowing for very low output impedance and very fast transient response.

The MIC49500 requires a bias input supply and a main input supply, allowing for ultra-low input voltages on the main supply rail. The input supply operates from 1.4V to 6V and the bias supply requires between 3V and 6V for proper operation. The MIC49500 can regulate to an output voltage as low as 0.7V, making it an ideal product for low-voltage to low-voltage conversion.

The MIC49500 requires a minimum of output capacitance for stability, working optimally with any type of capacitor, including small ceramic capacitors. Available in fixed output voltages from 0.9V to 1.8V and adjustable output voltages down to 0.7V, the MIC49500 comes in both 7-pin S-Pak and TO-263 packages. The MIC49500 is rated to the full operating temperature range of  $-40^{\circ}\text{C}$  to  $125^{\circ}\text{C}$  junction temperature.

### Features

- Input voltage range:
  - $V_{IN}$ : 1.4V to 6V
  - $V_{BIAS}$ : 3.0V to 6V
- Stable with 10 $\mu\text{F}$  ceramic output capacitor
- $\pm 1.0\%$  initial output tolerance
- Maximum dropout ( $V_{IN} - V_{OUT}$ ) is 500mV over temperature
- Adjustable output voltage down to 0.7V
- Ultra Fast Transient Response (Up to 10MHz bandwidth)
- Excellent line and load regulation specifications
- Logic controlled shutdown option
- Thermal shutdown and current limit protection
- Thin 7-pin S-Pak package
- TO-263 7-pin package
- $-40^{\circ}\text{C}$  to  $+125^{\circ}\text{C}$  operating junction temperature range

### Applications

- ASIC Core Voltage Regulator
- PLD/FPGA Core Power Supply
- Linear Point-of-Load Conversion
- High Speed Post-Regulator

### Typical Application

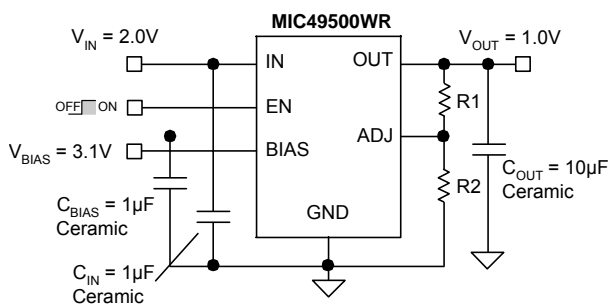

Low Voltage, Fast Transient Response Regulator

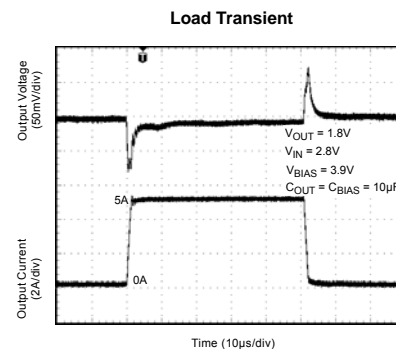

# Block Diagram

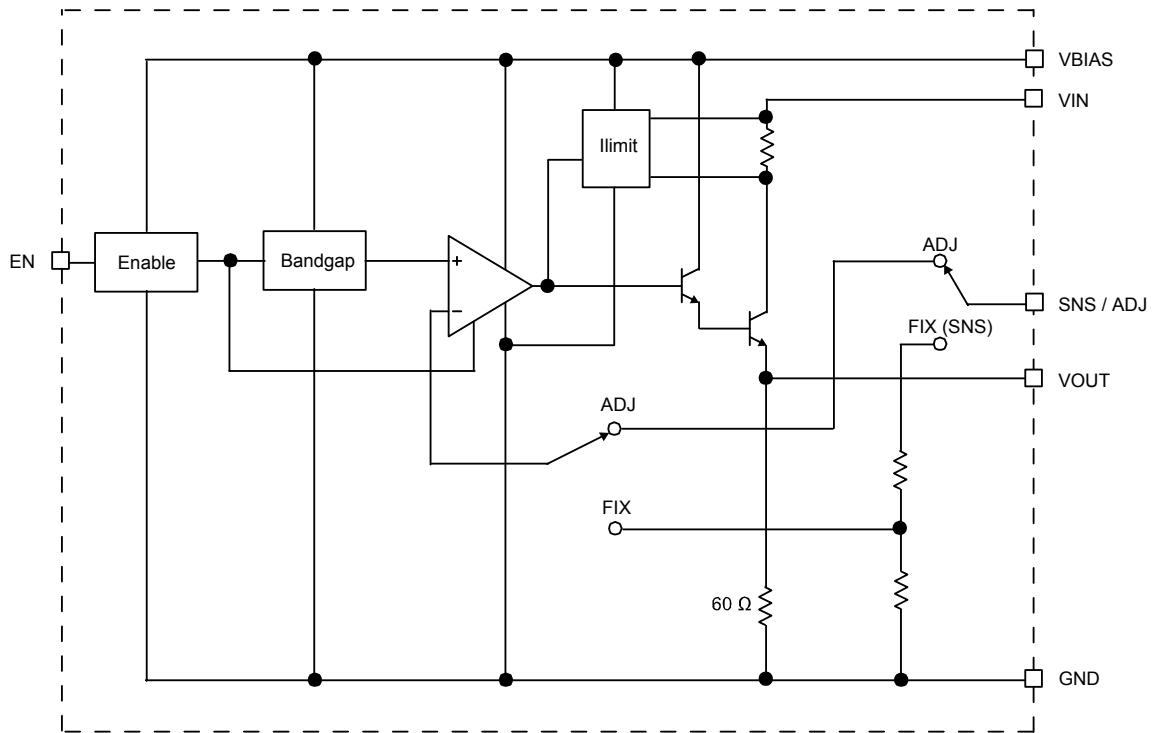

## Ordering Information

Part Number*	Voltage	Junction Temperature Range	Package	Lead Finish*
MIC49500-0.9WR	0.9V	-40°C to +125°C	S-Pak-7	RoHS Compliant
MIC49500-1.2WR	1.2V	-40°C to +125°C	S-Pak-7	RoHS Compliant
MIC49500WR	ADJ	-40°C to +125°C	S-Pak-7	RoHS Compliant
MIC49500-0.9WU	0.9V	-40°C to +125°C	TO-263	RoHS Compliant
MIC49500-1.2WU	1.2V	-40°C to +125°C	TO-263	RoHS Compliant
MIC49500WU	ADJ	-40°C to +125°C	TO-263	RoHS Compliant

Other Voltage available. Contact Micrel for details.

\* RoHS compliant with 'high-melting solder' exemption.

## Pin Configuration

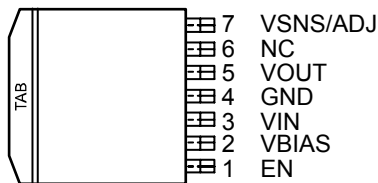

**MIC49500WR (S-Pak-7)**

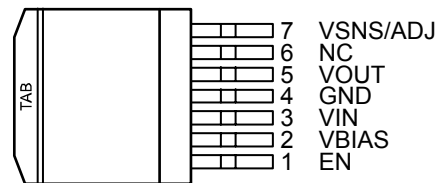

**MIC49500WU (TO263-7)**

## Pin Description

Pin Number S-Pak-7	Pin Name (Fixed)	Pin Name (Adj)	Pin Function
1	EN	EN	Enable: TTL/CMOS compatible input. Logic high = enable, logic low or open = shutdown.
2	VBIAS	VBIAS	Bias Supply: Bias supply input for powering all internal circuitry of the device, except the main current path.
3	VIN	VIN	Input Voltage: Main Power Input Supply. Supplies main current to output device.
4	GND	GND	Ground (TAB is connected to Ground).
5	VOUT	VOUT	Output Voltage: Regulator Output.
6	NC		No Connect
7	VSNS	-	Remote Voltage Sense: Connect direct the load to improve regulation. Connect direct to pin 5 if not used.
7	-	ADJ	Adjust Input. Connect external resistor divider to program output voltage.

### Absolute Maximum Ratings<sup>(1)</sup>

Supply Voltage ( $V_{IN}$ ).....	6.5V
Bias Supply Voltage ( $V_{BIAS}$ ).....	6.5V
Enable Input Voltage ( $V_{EN}$ ).....	6.5V
Power Dissipation.....	Internally Limited
Junction Temperature .....	$-40^{\circ}\text{C} \leq T_J \leq +125^{\circ}\text{C}$
Storage Temperature (TS).....	$-65^{\circ}\text{C} \leq T_J \leq 150^{\circ}\text{C}$
Lead Temperature (soldering, 5 sec.).....	260°C
ESD Rating <sup>(3)</sup> .....	3kV

### Operating Ratings<sup>(2)</sup>

Supply voltage ( $V_{IN}$ ).....	1.4V to 6V
Bias Supply Voltage ( $V_{BIAS}$ ).....	3V to 6V
Enable Input Voltage ( $V_{EN}$ ).....	0V to $V_{BIAS}$
Junction Temperature Range.....	$-40^{\circ}\text{C} \leq T_J \leq +125^{\circ}\text{C}$
Package Thermal Resistance	
S-Pak ( $\theta_{JC}$ ) .....	2°C/W
TO-263 ( $\theta_{JC}$ ) .....	2°C/W

### Electrical Characteristics<sup>(4)</sup>

$V_{IN} = V_{OUT} + 1.0\text{V}$ ;  $V_{BIAS} = V_{OUT} + 2.1\text{V}$ ;  $C_{OUT} = 10\mu\text{F}$ ;  $I_{OUT} = 10\text{mA}$ ;  $T_J = 25^{\circ}\text{C}$ , **bold** values indicate  $-40^{\circ}\text{C}$  to  $+125^{\circ}\text{C}$ , unless noted.

Parameter	Conditions	Min	Typ	Max	Units
Output Voltage Accuracy	At 25°C, fixed voltage options Over temperature range	-1 -2		+1 <b>+2</b>	% %
Output Voltage Line Regulation	$V_{IN} = V_{OUT} + 1\text{V to } 6\text{V}$	<b>-0.1</b>		<b>+0.1</b>	%/V
Output Voltage Load Regulation	$I_L = 10\text{mA to } 5\text{A}$		0.2	<b>1.0</b>	%
$V_{IN} - V_O$ ; Dropout Voltage	$I_L = 2.5\text{A}$ $I_L = 5.0\text{A}$		145 290	<b>300</b> <b>500</b>	mV mV
$V_{BIAS} - V_O$ ; Dropout Voltage	$I_L = 2.5\text{A}$ $I_L = 5.0\text{A}$		1.5 1.7	<b>2.0</b> <b>2.1</b>	V V
Ground Pin Current	$V_{OUT} = 1.2\text{V}$ ; $I_L = 0\text{mA}$ $V_{OUT} = 1.2\text{V}$ ; $I_L = 5.0\text{A}$ $0.7\text{V} \leq V_{OUT} \leq 1.8\text{V}$ $1.8\text{V} < V_{OUT} \leq 3.3\text{V}$		55 55 55 75	<b>90</b> <b>90</b> <b>130</b>	mA mA mA mA
Ground Pin Current in Shutdown	$V_{IL} \leq 0.6\text{V}$		0.1	<b>5</b>	$\mu\text{A}$
Current thru $V_{BIAS}$	$I_L = 0\text{mA}$ $I_L = 5.0\text{A}$		30 70	<b>50</b> <b>150</b>	mA mA
Current Limit	$V_{OUT} = 0\text{V}$	5.5	7.5	9.5	A
Feedback Current			50	<b>1000</b>	nA
<b>Enable Input</b>					
Enable Input Threshold	Regulator enable Regulator shutdown	<b>1.6</b>	1.2 1.15	<b>0.6</b>	V V
Enable Hysteresis		<b>20</b>	50	<b>150</b>	mV
Enable Pin Input Current			0.1	<b>5</b>	$\mu\text{A}$
Turn-on Time	$C_{OUT} = 10\mu\text{F}$ ; <b>Note 5</b>		10	<b>45</b>	$\mu\text{s}$
<b>Reference Voltage (Adjustable Output Only)</b>					
$V_{REF}$	$T_A = 25^{\circ}\text{C}$ $-40^{\circ}\text{C} < T_A < 125^{\circ}\text{C}$	0.693 <b>0.686</b>	0.7	0.707 <b>0.714</b>	V V

**Notes:**

1. Exceeding the absolute maximum rating may damage the device.
2. The device is not guaranteed to function outside its operating rating.
3. Devices are ESD sensitive. Handling precautions recommended. Human body model, 1.5k in series with 100pF.
4. Specification for packaged product only.
5. Turn-on time is measured from 10% of the positive edge of the enable signal to 90% of the rising edge of the output voltage of the regulator.

# Typical Characteristics

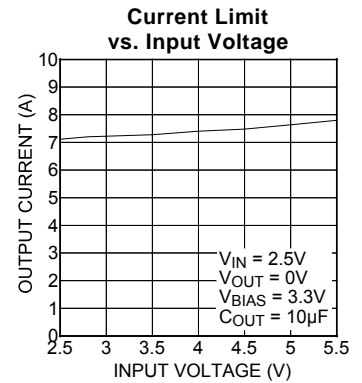
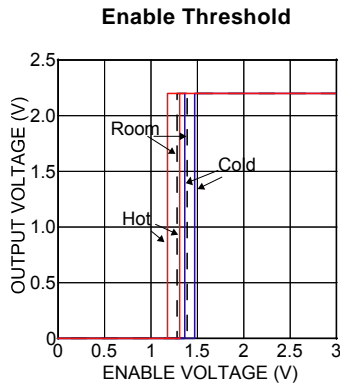
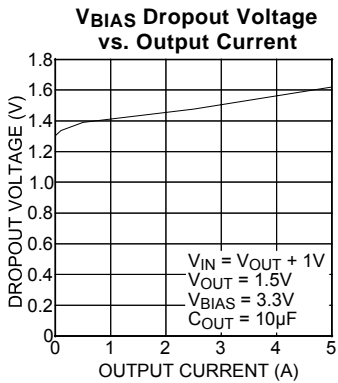
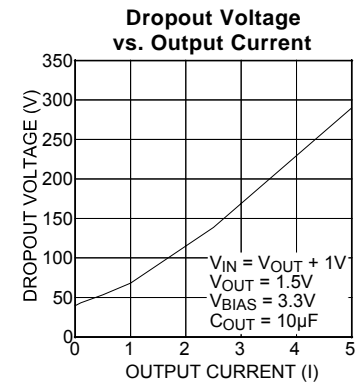
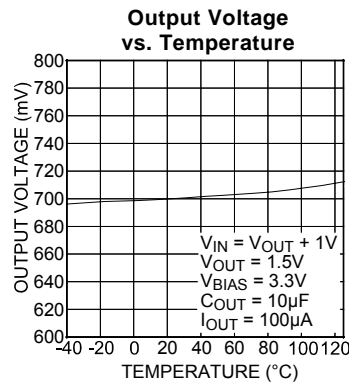
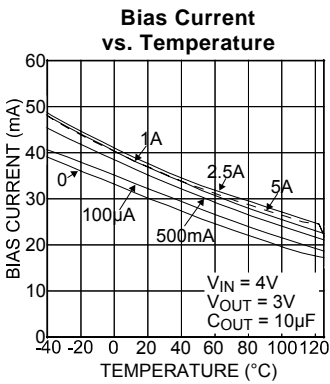
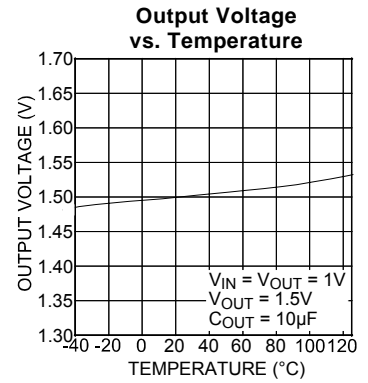
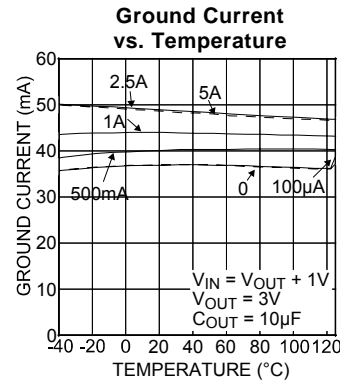
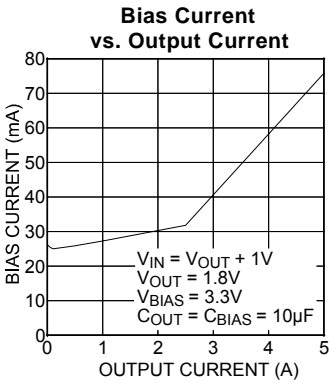
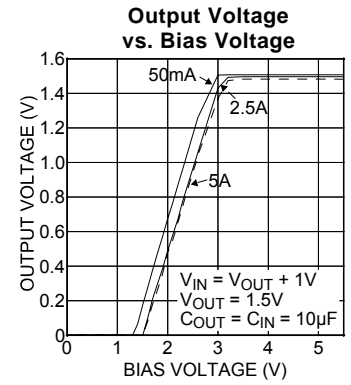
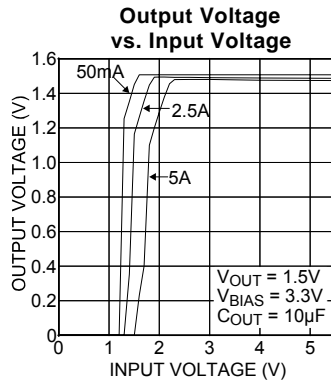
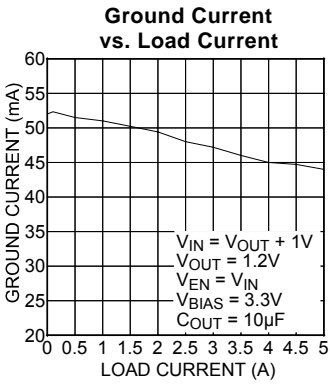

### Typical Characteristics (continued)

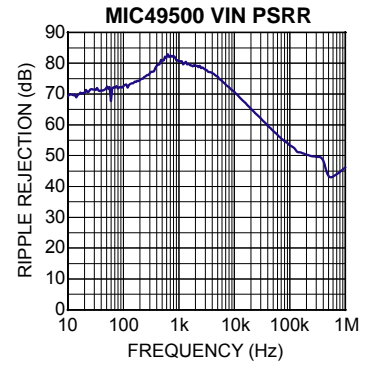
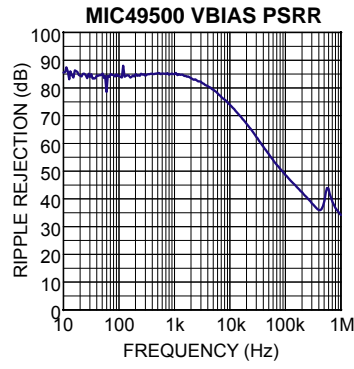
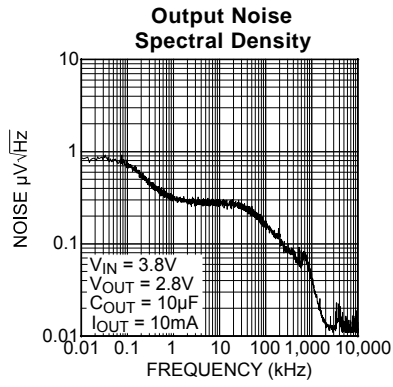

# Functional Characteristics

### Enable Turn-On

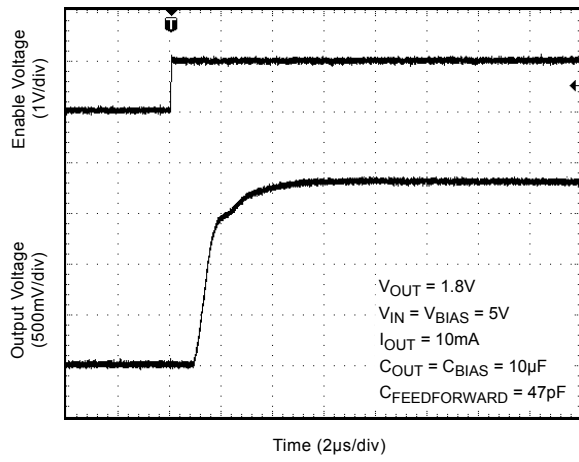

### Load Transient

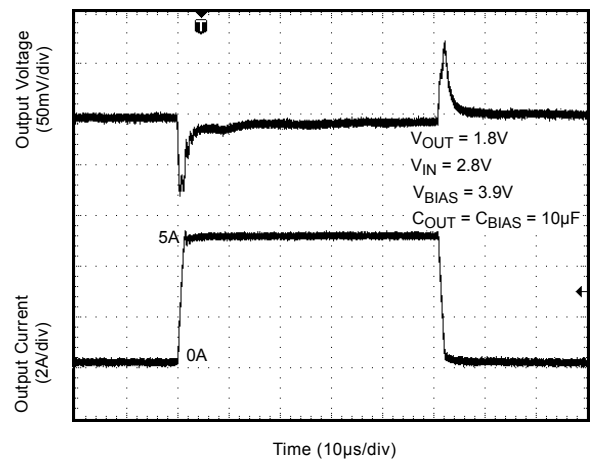

### Line Transient ( $V_{IN}$ )

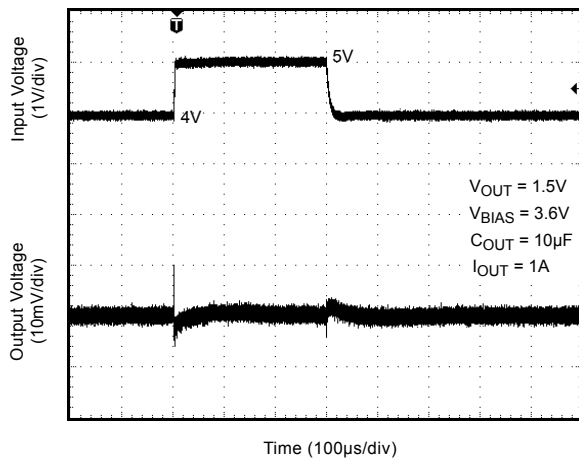

### Line Transient ( $V_{BIAS}$ )

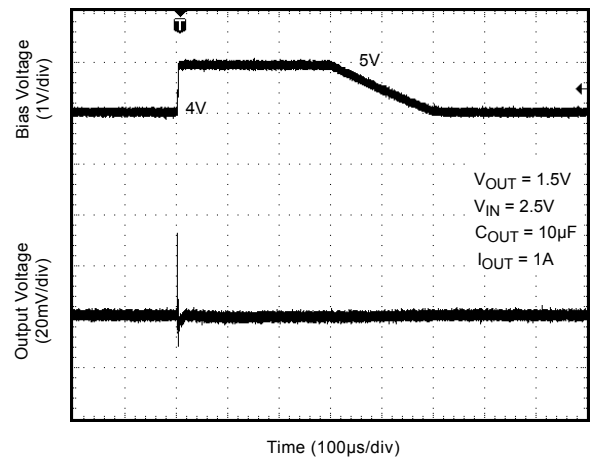

## Applications Information

The MIC49500 is an ultra-high performance, low dropout linear regulator designed for high current applications requiring fast transient response. The MIC49500 utilizes two input supplies, significantly reducing dropout voltage, perfect for low-voltage, DC-to-DC conversion. The MIC49500 requires a minimum of external components and obtains a bandwidth of up to 10MHz. As a  $\mu$ Cap regulator, the output is tolerant of virtually any type of capacitor including ceramic and tantalum.

The MIC49500 regulator is fully protected from damage due to fault conditions, offering constant current limiting and thermal shutdown.

### Bias Supply Voltage

$V_{BIAS}$ , requiring relatively light current, provides power to the control portion of the MIC49500.  $V_{BIAS}$  requires approximately 70mA for 5A load current. Most of the biasing current is used to supply the base current to the pass transistor. This allows the pass element to be driven into saturation, reducing the dropout to 290mV at a 5A load current. Bypassing on the bias pin is recommended to improve performance of the regulator during line and load transients. Small ceramic capacitors from  $V_{BIAS}$  to ground help reduce high frequency noise from being injected into the control circuitry from the bias rail and are good design practice. Good bypass techniques typically include one larger capacitor such as 1 $\mu$ F ceramic and smaller valued capacitors such as 0.01 $\mu$ F or 0.001 $\mu$ F in parallel with that larger capacitor to decouple the bias supply. The  $V_{BIAS}$  input voltage must be 2.1V above the output voltage with a minimum  $V_{BIAS}$  input voltage of 3.0V.

### Input Supply Voltage

$V_{IN}$  provides the high current to the collector of the pass transistor. The minimum input voltage is 1.4V, allowing conversion from low voltage supplies.

### Output Capacitor

The MIC49500 requires a minimum of output capacitance to maintain stability. However, proper capacitor selection is important to ensure desired transient response. The MIC49500 is specifically designed to be stable with a wide range of capacitance values and ESR. A 10 $\mu$ F ceramic chip capacitor should satisfy most applications. Output capacitance can be increased without bound. See typical characteristics for examples of load transient response.

X7R dielectric ceramic capacitors are recommended because of their temperature performance. X7R-type

capacitors change capacitance by 15% over their operating temperature range and are the most stable type of ceramic capacitors. Z5U and Y5V dielectric capacitors change value by as much as 50% and 60%, respectively, over their operating temperature ranges. To use a ceramic chip capacitor with Y5V dielectric, the value must be much higher than an X7R ceramic or a tantalum capacitor to ensure the same capacitance value over the operating temperature range. Tantalum capacitors have a very stable dielectric (10% over their operating temperature range) and can also be used with this device.

### Input Capacitor

An input capacitor of 1 $\mu$ F or greater is recommended when the device is more than 4 inches away from the bulk supply capacitance, or when the supply is a battery. Small, surface mount, ceramic chip capacitors can be used for the bypassing. The capacitor should be placed within 1" of the device for optimal performance. Larger values will help to improve ripple rejection by bypassing the input to the regulator, further improving the integrity of the output voltage.

### Thermal Design

Linear regulators are simple to use. The most complicated design parameters to consider are thermal characteristics. Thermal design requires the following application-specific parameters:

- Maximum ambient temperature ( $T_A$ )
- Output Current ( $I_{OUT}$ )
- Output Voltage ( $V_{OUT}$ )
- Input Voltage ( $V_{IN}$ )
- Ground Current ( $I_{GND}$ )

First, calculate the power dissipation of the regulator from these numbers and the device parameters from this datasheet.

$$P_D = V_{IN} \times I_{IN} + V_{BIAS} \times I_{BIAS} - V_{OUT} \times I_{OUT}$$

The input current will be less than the output current as the output load increases. The bias current is a sum of base drive and ground current. Ground current is constant over load current. Then the heat sink thermal resistance is determined with this formula:

$$\theta_{SA} = \left( \frac{T_{J(MAX)} \pm T_A}{P_D - (\theta_{JC} + \theta_{CS})} \right)$$

The heat sink may be significantly reduced in applications where the maximum input voltage is known and large compared with the dropout voltage. Use a series input resistor to drop excessive voltage and distribute the heat between this resistor and the

regulator. The low dropout properties of the MIC49500 allow significant reductions in regulator power dissipation and the associated heat sink without compromising performance. When this technique is employed, a capacitor of at least 1 $\mu$ F is needed directly between the input and regulator ground. Refer to Application Note 9 for further details and examples on thermal design and heat sink specification.

#### **Minimum Load Current**

The MIC49500, unlike most other high current regulators, does not require a minimum load to maintain output voltage regulation.

#### **Power Sequencing**

There is no power sequencing requirement for  $V_{IN}$  and  $V_{BIAS}$ , giving more flexibility to the user.

#### **Adjustable Regulator Design**

The MIC49500 adjustable version allows programming the output voltage anywhere between 0.7V and 6V. Two resistors are used. The resistor value between  $V_{OUT}$  and the adjust pin should not exceed 10k $\Omega$ . Larger values can cause instability. The resistor values are calculated by:

$$R1 = R2 \times \left( \frac{V_{OUT}}{0.7} - 1 \right)$$

Where  $V_{OUT}$  is the desired output voltage.

#### **Enable**

The fixed output voltage versions of the MIC49500 feature an active high enable input (EN) that allows on-off control of the regulator. Current drain reduces to “zero” when the device is shutdown, with only microamperes of leakage current. The EN input has TTL/CMOS compatible thresholds for simple logic interfacing. EN may be directly tied to  $V_{IN}$  and pulled up to the maximum supply voltage.

# Package Information

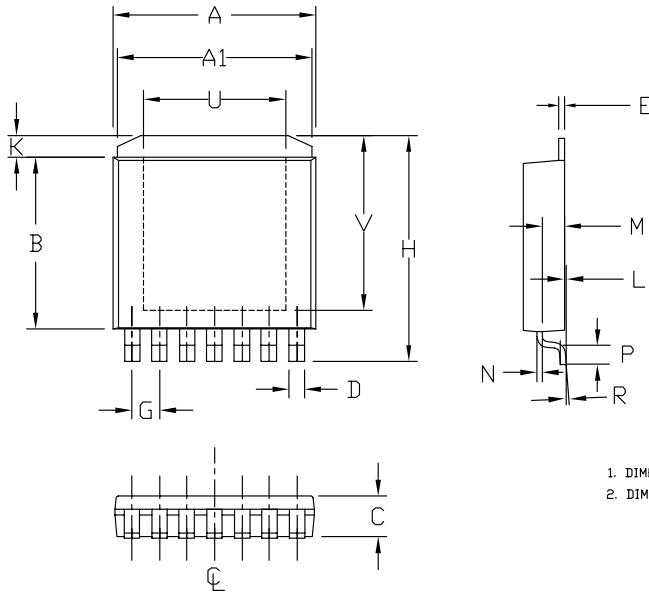

	INCHES		MILLIMETERS	
A	0.365	0.375	9.27	9.52
A1	0.350	0.360	8.89	9.14
B	0.310	0.320	7.87	8.13
C	0.070	0.080	1.78	2.03
D	0.025	0.031	0.63	0.79
E	0.010	BSC	0.25	BSC
G	0.050	BSC	1.27	BSC
H	0.410	0.420	10.41	10.67
K	0.030	0.050	0.76	1.27
L	0.001	0.005	0.03	0.13
M	0.035	0.045	0.89	1.14
N	0.010	BSC	0.25	BSC
P	0.031	0.041	0.79	1.04
R	0°	6°	0°	6°
U	0.256	BSC	6.50	BSC
V	0.316	BSC	8.03	BSC

1. DIMENSION DOES NOT INCLUDE MOLD FLASH OR PROTRUSIONS.
2. DIMENSION INCLUDES PLATING THICKNESS.

## 7-Pin SPAK (R)

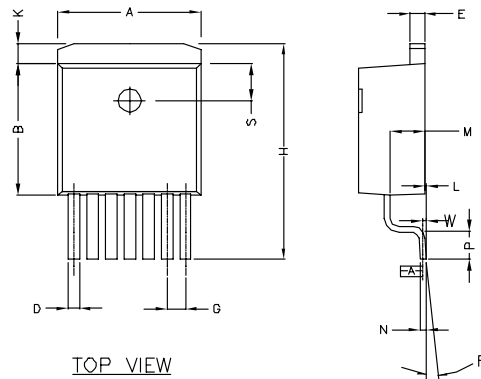

TOP VIEW

SIDE VIEW 1

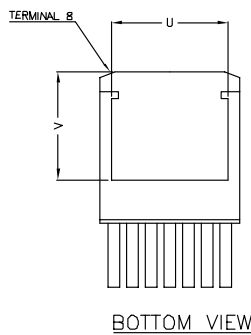

BOTTOM VIEW

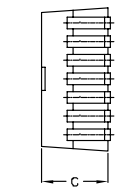

SIDE VIEW 2

POS	INCHES		MILLIMETERS	
	MIN	MAX	MIN	MAX
A	.396	.406	10.05	10.31
B	.330	.340	8.38	8.64
C	.170	.180	4.31	4.57
D	.026	.036	0.66	0.91
E	.045	.055	1.14	1.40
G	.050 ref		1.27 ref	
H	.580	.620	14.75	15.75
K	.055	.066	1.40	1.68
L	.000	.010	0.00	0.25
M	.098	.108	2.49	2.74
N	.017	.023	0.43	0.58
P	.080	.110	2.29	2.79
R	0°	8°	0°	8°
S	.095	.105	2.41	2.67
U	.30 ref		7.62 ref	
Y	.305 ref		7.75 ref	
W	.010		0.25	

## 7-Pin TO-263 (U)

---

**MICREL, INC. 2180 FORTUNE DRIVE SAN JOSE, CA 95131 USA**  
TEL +1 (408) 944-0800 FAX +1 (408) 474-1000 WEB <http://www.micrel.com>

The information furnished by Micrel in this data sheet is believed to be accurate and reliable. However, no responsibility is assumed by Micrel for its use. Micrel reserves the right to change circuitry and specifications at any time without notification to the customer.

Micrel Products are not designed or authorized for use as components in life support appliances, devices or systems where malfunction of a product can reasonably be expected to result in personal injury. Life support devices or systems are devices or systems that (a) are intended for surgical implant into the body or (b) support or sustain life, and whose failure to perform can be reasonably expected to result in a significant injury to the user. A Purchaser's use or sale of Micrel Products for use in life support appliances, devices or systems is a Purchaser's own risk and Purchaser agrees to fully indemnify Micrel for any damages resulting from such use or sale.

© 2005 Micrel, Inc.

## Looking for pricing, stock, or lifecycle information?

Click below to explore more details on WIN SOURCE:

- ⊖ [View MIC49500WU on WIN SOURCE](#)
- ⊖ [Microchip Technology Information](#)

## Optimize Your Supply Chain with WIN SOURCE Solutions

- ✓ Global Sourcing Solution
- ✓ Obsolete Management
- ✓ Cost Control Management
- ✓ Shortage Management
- ✓ Alternative Solution
- ✓ Excess Inventory Management