



**THE DATASHEET OF
MJ10012**





ELECTRONICS, INC.
 44 FARRAND STREET
 BLOOMFIELD, NJ 07003
 (973) 748-5089
<http://www.nteinc.com>

MJ10012 NPN Silicon Power Darlington Transistor TO-3 Type Package

Description:

The MJ10012 is high-voltage, high-current Darlington transistor in a TO-3 type package designed for automotive ignition, switching regulation and motor control applications.

Features:

- Collector-Emitter Sustaining Voltage: $V_{CEO(sus)} = 400Vdc$ (Min)
- 175 Watts Capability at 50 Volts

Absolute Maximum Ratings:

Collector-Emitter Voltage, V_{CEO}	400V
Collector-Emitter Voltage ($R_{BE} = 27\Omega$), V_{CER}	550V
Collector-Base Voltage, V_{CBO}	600V
Emitter-Base Voltage, V_{EBO}	8V
Collector Current, I_C	
Continuous	10A
Peak (Note 1)	15A
Base Current, I_B	2A
Total Power Dissipation, P_D	
$T_C = +25^\circ C$	175W
$T_C = +100^\circ C$	100W
Derate Above $25^\circ C$	1.0W/ $^\circ C$
Operating Junction Temperature Range, T_J	-65° to $+200^\circ C$
Storage Temperature Range, T_{stg}	-65° to $+200^\circ C$
Thermal Resistance, Junction-to-Case, R_{thJC}	1.0 $^\circ C/W$
Lead Temperature (During Soldering, 1/8" from case, 5 sec), T_L	$+275^\circ C$

Note 1. Pulse Test: Pulse Width = 5ms, Duty Cycle $\leq 10\%$.

Electrical Characteristics: ($T_C = +25^\circ\text{C}$ unless otherwise specified)

Parameter	Symbol	Test Conditions	Min	Typ	Max	Unit
OFF Characteristics (Note 2)						
Collector-Emitter Sustaining Voltage	$V_{CEO(sus)}$	$I_C = 200\text{mA}, I_B = 0, V_{clamp} = 400\text{V}$	400	-	-	V
	$V_{CER(sus)}$	$I_C = 200\text{mA}, R_{BE} = 27\Omega, V_{clamp} = 400\text{V}$	425	-	-	V
Collector Cutoff Current	I_{CER}	$V_{CER} = 550\text{V}, R_{BE} = 27\Omega$	-	-	1.0	mA
	I_{CBO}	$V_{CBO} = 600\text{V}, I_E = 0$	-	-	1.0	mA
Emitter Cutoff Current	I_{EBO}	$V_{EB} = 6\text{V}, I_C = 0$	-	-	40	mA
ON Characteristics (Note 3)						
DC Current Gain	h_{FE}	$V_{CE} = 6\text{V}, I_C = 3\text{A}$	300	550	-	
		$V_{CE} = 6\text{V}, I_C = 6\text{A}$	100	350	2000	
		$V_{CE} = 6\text{V}, I_C = 10\text{A}$	20	150	-	
Collector-Emitter Saturation Voltage	$V_{CE(sat)}$	$I_C = 3\text{A}, I_B = 600\text{mA}$	-	-	1.5	V
		$I_C = 6\text{A}, I_B = 600\text{mA}$	-	-	2.0	V
		$I_C = 10\text{A}, I_B = 2\text{A}$	-	-	2.5	V
Base-Emitter Saturation Voltage	$V_{BE(sat)}$	$I_C = 6\text{A}, I_B = 600\text{mA}$	-	-	2.5	V
		$I_C = 10\text{A}, I_B = 2\text{A}$	-	-	3.0	V
Base-Emitter ON Voltage	$V_{BE(on)}$	$I_C = 10\text{A}, V_{CE} = 6\text{V}$	-	-	2.8	V
Diode Forward Voltage	V_F	$I_F = 10\text{A}$	-	2.0	3.5	V
Dynamic Characteristics						
Output Capacitance	C_{ob}	$V_{CB} = 10\text{V}, I_E = 0, f_{test} = 100\text{kHz}$	165	-	350	pF
Switching Characteristics						
Storage Time	t_s	$V_{CC} = 12\text{V}, I_C = 6\text{A}, I_{B1} = I_{B2} = 300\text{mA}$	-	7.5	15	μs
Fall Time	t_f		-	5.2	15	μs
Functional Tests						
Pulsed Energy Test	$I_C 2L/2$		-	-	180	mJ

Note 2. Pulse Test: Pulse Width = $300\mu\text{s}$, Duty Cycle = 2%.

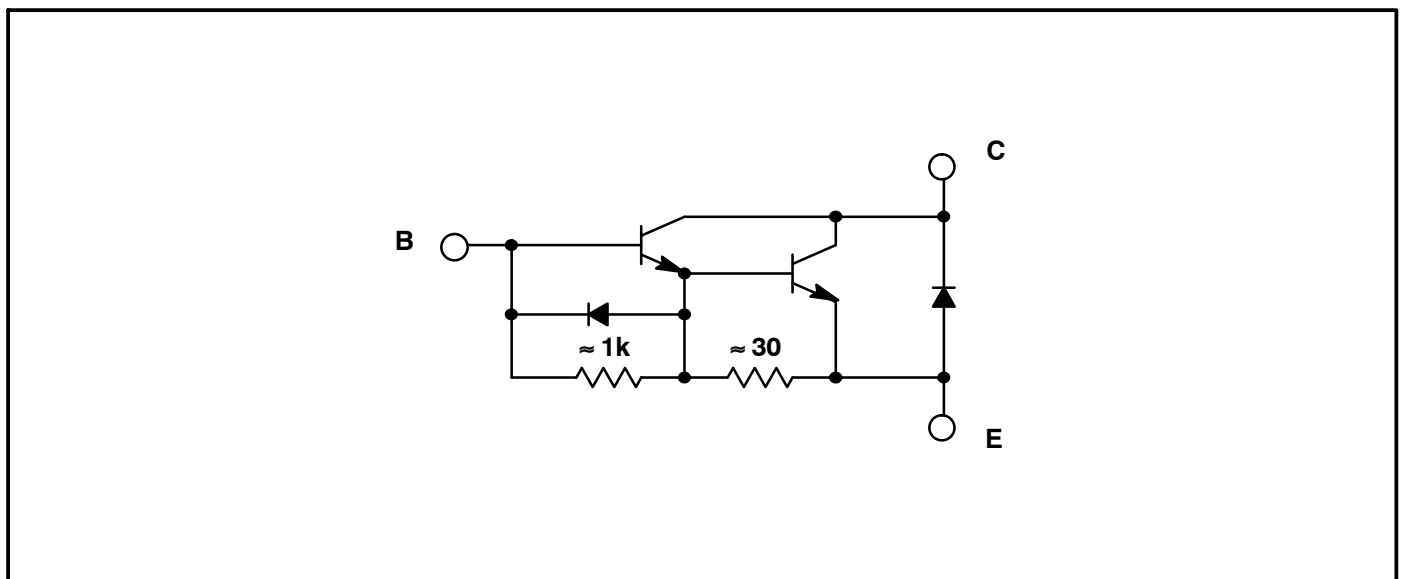

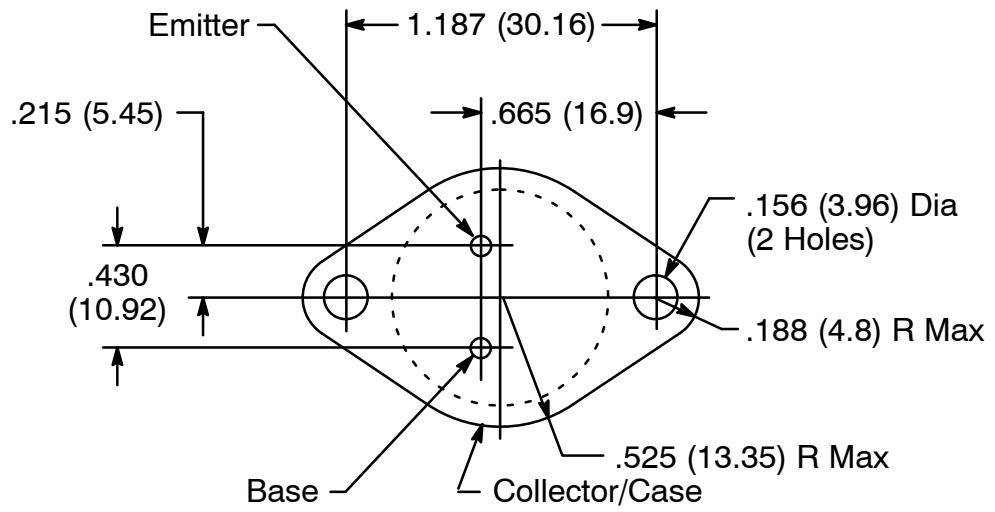
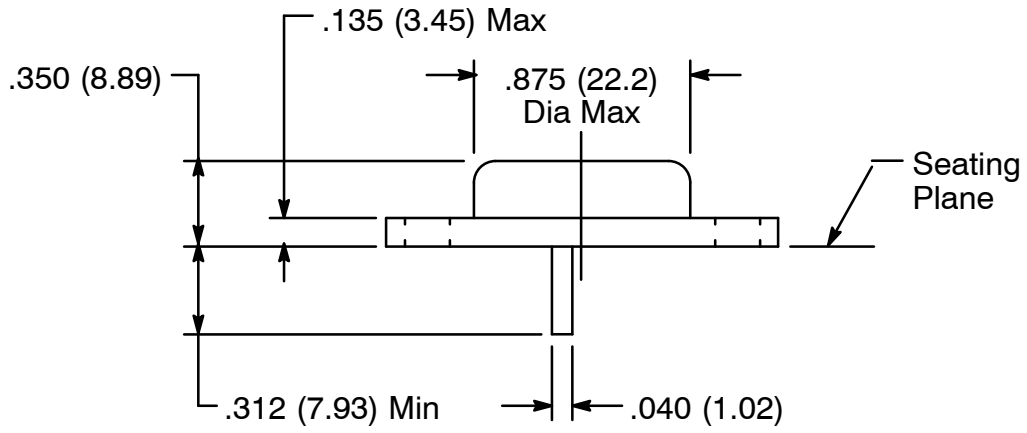

Looking for pricing, stock, or lifecycle information?

Click below to explore more details on WIN SOURCE:

 [View MJ10012 on WIN SOURCE](#)

 [NTE Information](#)

Optimize Your Supply Chain with WIN SOURCE Solutions

-  Global Sourcing Solution
-  Obsolete Management
-  Cost Control Management
-  Shortage Management
-  Alternative Solution
-  Excess Inventory Management