



**THE DATASHEET OF  
MM74C240N**



## MM74C240 • MM74C244

### Inverting • Non-Inverting Octal Buffer and Line Driver with 3-STATE Outputs

#### General Description

The MM74C240 and MM74C244 octal buffers and line drivers are monolithic complementary MOS (CMOS) integrated circuits with 3-STATE outputs. These outputs have been specially designed to drive highly capacitive loads such as bus-oriented systems. These devices have a fan out of 6 low power Schottky loads. A high logic level on the output disable control input G makes the outputs go into the high impedance state.

#### Features

- Wide supply voltage range (3V to 15V)
- High noise immunity (0.45  $V_{CC}$  typ)
- Low power consumption
- High capacitive load drive capability
- 3-STATE outputs
- Input protection
- TTL compatibility
- 20-pin dual-in-line package
- High speed 25 ns (typ.) @ 10V, 50 pF (MM74C244)

#### Ordering Code:

Order Number	Package Number	Package Description
MM74C240WM	M20B	20-Lead Small Outline Integrated Circuit (SOIC), JEDEC MS-013, 0.300" Wide
MM74C240N	N20A	20-Lead Plastic Dual-In-Line Package (PDIP), JEDEC MS-001, 0.300" Wide
MM74C244WM	M20B	20-Lead Small Outline Integrated Circuit (SOIC), JEDEC MS-013, 0.300" Wide
MM74C244N	N20A	20-Lead Plastic Dual-In-Line Package (PDIP), JEDEC MS-001, 0.300" Wide

Devices also available in Tape and Reel. Specify by appending suffix letter "X" to the ordering code.

#### Connection Diagrams

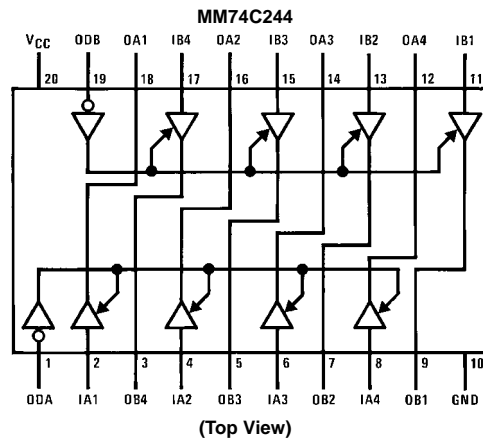
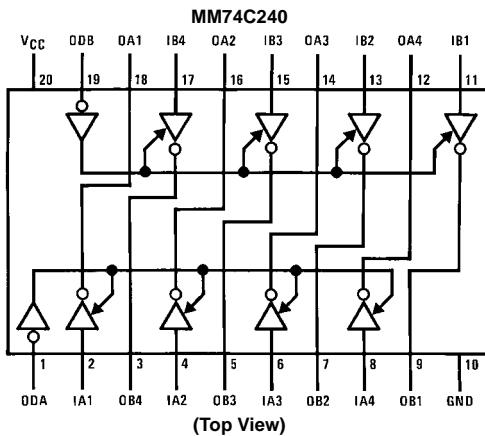

## Logic Diagrams

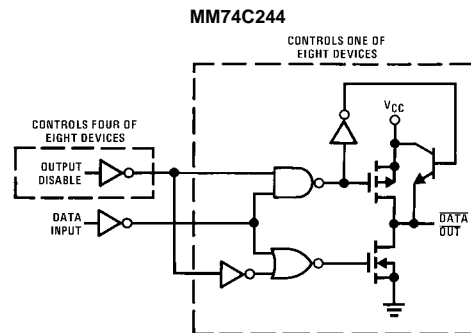
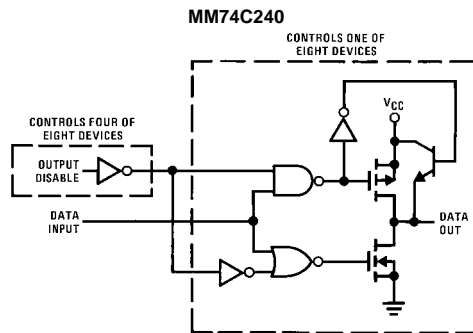

## Truth Tables

**MM74C240**

ODA	IA	OA
1	X	Z
1	X	Z
0	0	1
0	1	0

ODB	IB	OB
1	X	Z
1	X	Z
0	0	1
0	1	0

1 = HIGH  
0 = LOW

**MM74C244**

ODA	IA	OA
1	X	Z
1	X	Z
0	0	0
0	1	1

ODB	IB	OB
1	X	Z
1	X	Z
0	0	0
0	1	1

X = Don't Care  
Z = 3-STATE

### Absolute Maximum Ratings (Note 1)

Voltage at Any Pin	-0.3V to $V_{CC} + 0.3V$
Operating Temperature Range	-55°C to +125°C
Storage Temperature Range	-65°C to +150°C
Power Dissipation	
Dual-In-Line	700 mW
Small Outline	500 mW
Operating $V_{CC}$ Range	3V to 15V
Absolute Maximum $V_{CC}$	18V
Lead Temperature	
(Soldering, 10 seconds)	260°C

**Note 1:** "Absolute Maximum Ratings" are those values beyond which the safety of the device cannot be guaranteed. Except for "Operating Range" they are not meant to imply that the devices should be operated at these limits. The Electrical Characteristics table provides conditions for actual device operation.

### DC Electrical Characteristics

Min/Max limits apply across temperature range, unless otherwise noted

Symbol	Parameter	Conditions	Min	Typ	Max	Units
<b>CMOS TO CMOS</b>						
$V_{IN(1)}$	Logical "1" Input Voltage	$V_{CC} = 5V$ $V_{CC} = 10V$	3.5 8.0			V
$V_{IN(0)}$	Logical "0" Input Voltage	$V_{CC} = 5V$ $V_{CC} = 10V$			1.5 2.0	V
$V_{OUT(1)}$	Logical "1" Output Voltage	$V_{CC} = 5V, I_O = -10 \mu A$ $V_{CC} = 10V, I_O = -10 \mu A$	4.5 9.0			V
$V_{OUT(0)}$	Logical "0" Output Voltage	$V_{CC} = 5V, I_O = 10 \mu A$ $V_{CC} = 10V, I_O = 10 \mu A$			0.5 1.0	V
$I_{OZ}$	3-STATE Output Current	$V_{CC} = 10V, OD = V_{IH}$			$\pm 10$	$\mu A$
$I_{IN(1)}$	Logical "1" Input Current	$V_{CC} = 15V, V_{IN} = 15V$		0.005	1.0	$\mu A$
$I_{IN(0)}$	Logical "0" Input Current	$V_{CC} = 15V, V_{IN} = 0V$	-1.0	-0.005		$\mu A$
$I_{CC}$	Supply Current	$V_{CC} = 15V$		0.05	300	$\mu A$
<b>CMOS/LPTTL INTERFACE</b>						
$V_{IN(1)}$	Logical "1" Input Voltage	$V_{CC} = 4.75V$		$V_{CC} - 1.5$		V
$V_{IN(0)}$	Logical "0" Input Voltage	$V_{CC} = 4.75V$			0.8	V
$V_{OUT(1)}$	Logical "1" Output Voltage	$V_{CC} = 4.75V, I_O = -450 \mu A$	$V_{CC} - 0.4$			V
		$V_{CC} = 4.75V, I_O = -2.2 mA$	2.4			V
$V_{OUT(0)}$	Logical "0" Output Voltage	$V_{CC} = 4.75V, I_O = 2.2 mA$			0.4	V
<b>OUTPUT DRIVE (See Family Characteristics Data Sheet) (Short Circuit Current)</b>						
$I_{SOURCE}$	Output Source Current (P-Channel)	$V_{CC} = 5V, V_{OUT} = 0V$ $T_A = 25^\circ C$	-14	-30		mA
		$V_{CC} = 10V, V_{OUT} = 0V$ $T_A = 25^\circ C$	-36	-70		mA
$I_{SINK}$	Output Sink Current (N-Channel)	$V_{CC} = 5V, V_{OUT} = V_{CC}$ $T_A = 25^\circ C$	12	20		mA
		$V_{CC} = 10V, V_{OUT} = V_{CC}$ $T_A = 25^\circ C$	48	70		mA

AC Electrical Characteristics (Note 2)						
$T_A = 25^\circ\text{C}$ , $C_L = 50\text{ pF}$ , unless otherwise specified						
Symbol	Parameter	Conditions	Min	Typ	Max	Units
$t_{PD(1)}$ , $t_{PD(0)}$	Propagation Delay (Data In to Out) MM74C240	$V_{CC} = 5\text{V}$ , $C_L = 50\text{ pF}$ $V_{CC} = 10\text{V}$ , $C_L = 50\text{ pF}$ $V_{CC} = 5\text{V}$ , $C_L = 150\text{ pF}$ $V_{CC} = 10\text{V}$ , $C_L = 150\text{ pF}$		60 40 80 60	90 70 110 90	ns
	MM74C244	$V_{CC} = 5\text{V}$ , $C_L = 50\text{ pF}$ $V_{CC} = 10\text{V}$ , $C_L = 50\text{ pF}$ $V_{CC} = 5\text{V}$ , $C_L = 150\text{ pF}$ $V_{CC} = 10\text{V}$ , $C_L = 150\text{ pF}$		45 25 60 40	70 50 90 70	ns
$t_{1H}$ , $t_{0H}$	Propagation Delay Output Disable to High Impedance State (from a Logic Level)	$R_L = 1\text{k}$ , $C_L = 50\text{ pF}$ $V_{CC} = 5\text{V}$ $V_{CC} = 10\text{V}$		45 35	80 60	ns
$t_{H1}$ , $t_{H0}$	Propagation Delay Output Disable to Logic Level (from High Impedance State)	$R_L = 1\text{k}$ , $C_L = 50\text{ pF}$ $V_{CC} = 5\text{V}$ $V_{CC} = 10\text{V}$		50 30	90 60	ns
$t_{T(HL)}$ , $t_{T(LH)}$	Transition Time	$V_{CC} = 5\text{V}$ , $C_L = 50\text{ pF}$ $V_{CC} = 10\text{V}$ , $C_L = 50\text{ pF}$ $V_{CC} = 5\text{V}$ , $C_L = 150\text{ pF}$ $V_{CC} = 10\text{V}$ , $C_L = 150\text{ pF}$		45 30 75 50	80 60 140 100	ns
$C_{PD}$	Power Dissipation Capacitance (Output Enabled per Buffer) MM74C240 MM74C244	(Note 3)		100 100		pF
	(Output Disabled per Buffer) MM74C240 MM74C244			10 0		pF
$C_{IN}$	Input Capacitance (Note 4) (Any Input)	$V_{IN} = 0\text{V}$ , $f = 1\text{ MHz}$ , $T_A = 25^\circ\text{C}$		10		pF
$C_O$	Output Capacitance (Note 4) (Output Disabled)	$V_{IN} = 0\text{V}$ , $f = 1\text{ MHz}$ , $T_A = 25^\circ\text{C}$		10		pF
<p><b>Note 2:</b> AC Parameters are guaranteed by DC correlated testing.</p> <p><b>Note 3:</b> <math>C_{PD}</math> determines the no load AC power consumption of any CMOS device. For complete explanation see Family Characteristics Application Note, AN-90.</p> <p><b>Note 4:</b> Capacitance is guaranteed by periodic testing.</p>						

### Typical Application

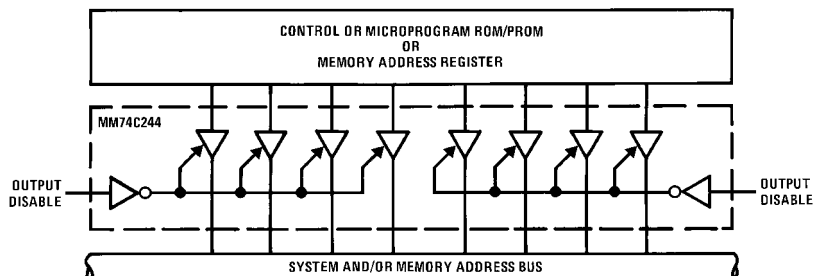

### Typical Performance Characteristics

N-Channel Output Drive at 25°C

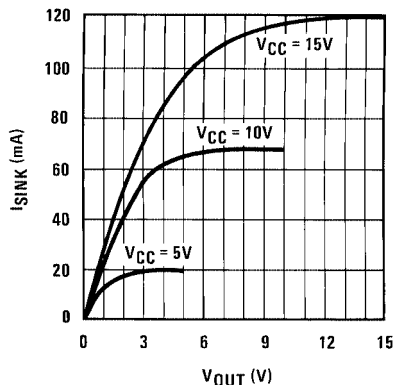

P-Channel Output Drive at 25°C

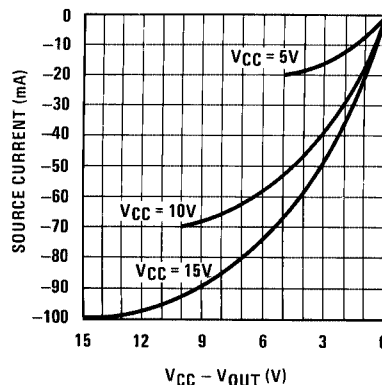

MM74C240  
Propagation Delay vs. Load Capacitance

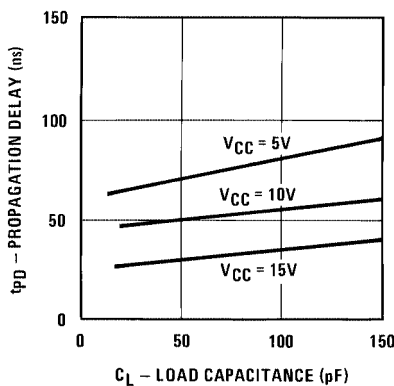

MM74C244  
Propagation Delay vs. Load Capacitance

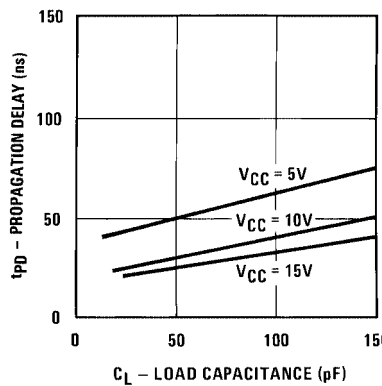

AC Test Circuits and Switching Time Waveforms

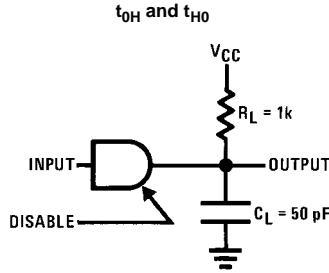
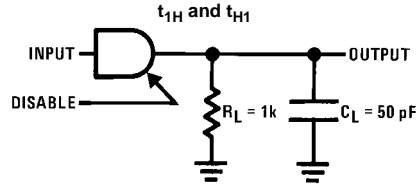
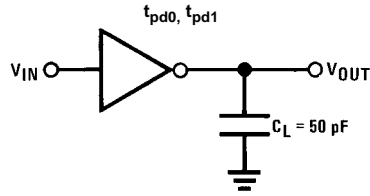

Note: Delays measured with input  $t_r, t_f \leq 20$  ns.

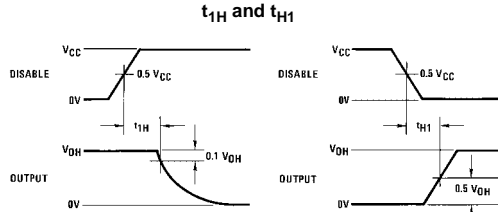
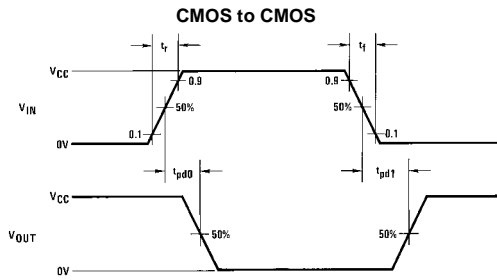

Note:  $V_{OH}$  is defined as the DC output high voltage when the device is loaded with a 1 k $\Omega$  resistor to ground.

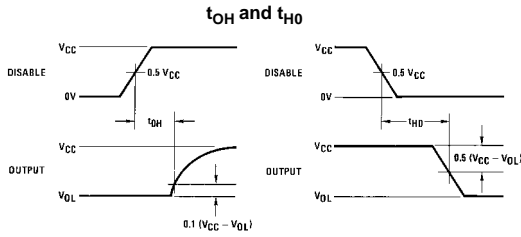

Note:  $V_{OL}$  is defined as the DC output low voltage when the device is loaded with a 1 k $\Omega$  resistor to  $V_{CC}$ .

**Physical Dimensions** inches (millimeters) unless otherwise noted



**20-Lead Small Outline Integrated Circuit (SOIC), JEDEC MS-013, 0.300" Wide Package Number M20B**

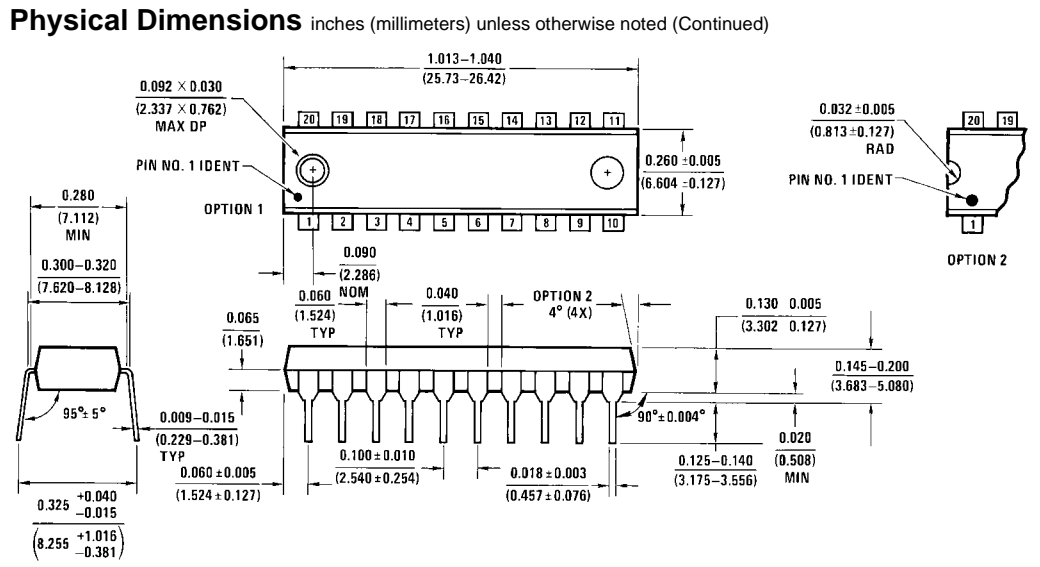

20-Lead Plastic Dual-In-Line Package (PDIP), JEDEC MS-001, 0.300" Wide  
Package Number N20A

Fairchild does not assume any responsibility for use of any circuitry described, no circuit patent licenses are implied and Fairchild reserves the right at any time without notice to change said circuitry and specifications.

**LIFE SUPPORT POLICY**

FAIRCHILD'S PRODUCTS ARE NOT AUTHORIZED FOR USE AS CRITICAL COMPONENTS IN LIFE SUPPORT DEVICES OR SYSTEMS WITHOUT THE EXPRESS WRITTEN APPROVAL OF THE PRESIDENT OF FAIRCHILD SEMICONDUCTOR CORPORATION. As used herein:

1. Life support devices or systems are devices or systems which, (a) are intended for surgical implant into the body, or (b) support or sustain life, and (c) whose failure to perform when properly used in accordance with instructions for use provided in the labeling, can be reasonably expected to result in a significant injury to the user.
2. A critical component in any component of a life support device or system whose failure to perform can be reasonably expected to cause the failure of the life support device or system, or to affect its safety or effectiveness.

[www.fairchildsemi.com](http://www.fairchildsemi.com)

## Looking for pricing, stock, or lifecycle information?

Click below to explore more details on WIN SOURCE:

- ⊖ [View MM74C240N on WIN SOURCE](#)
- ⊖ [Fairchild/ON Semiconductor Information](#)

## Optimize Your Supply Chain with WIN SOURCE Solutions

- ✓ Global Sourcing Solution
- ✓ Obsolete Management
- ✓ Cost Control Management
- ✓ Shortage Management
- ✓ Alternative Solution
- ✓ Excess Inventory Management